



Victoria Government Gazette

No. G 34 Thursday 27 August 1998

GENERAL

GENERAL AND PERIODICAL GAZETTE

Copy to: Gazette Officer
The Craftsman Press Pty. Ltd.
125 Highbury Road,
Burwood Vic 3125
Telephone: (03) 9926 1233
Facsimile: (03) 9926 1292
DX: 32510 Burwood
Email: gazette@craftpress.com.au

Advertising Rates and Payment

Private Notices

Payment must be received in advance with advertisement details.

30 cents per word - Full page \$180.00.

Additional costs must be included in prepayment if a copy of the gazette is required. Copy Prices - Page

\$1.50 - Gazette \$3.20 Certified copy of Gazette \$3.50. (all prices include Postage). **Cheques should be made payable to The Craftsman Press Pty. Ltd.**

Government and Outer Budget Sector Agencies Notices

Not required to pre-pay.

Advertisements may be faxed or sent via email with a cover sheet, marked to the attention of the Gazette Officer.

Floppy Disks (Mac & PC) can also be accepted.

Costs can be calculated on the following basis:

Per Line	Typeset
Single column	\$1.55
Double column	\$3.10
Full Page	\$64.80

The Craftsman Press is pleased to offer a series of discounts from the typesetting costs.

1. Copy supplied on disk.
2. Copy supplied via email.
3. Artwork for forms and other material which require exact reproduction.

1. Copy supplied on disk.

Where a disk is supplied and there is minimum alteration required, **30% off.**

Where a disk is supplied requiring extraneous matter stripped out and styles applied, **20% off.**

2. Copy supplied via email.

Where a notice is sent via email and there is minimum alteration required, **25% off.**

Where email is supplied requiring extraneous matter stripped out and styles applied, **15% off.**

3. Artwork for forms and other material which requires exact reproduction.

Scanning and sizing of artwork for forms, to be reproduced in page format, **35% off.**

Copy Deadline for General Gazette

9.30 a.m. Monday - (Private Notices)

9.30 a.m. Tuesday - (Government and Outer Budget Sector Agencies Notices)

Advertisers should note:

- Late copy received at The Craftsman Press Pty. Ltd. after deadlines will be placed in the following issue of VGG, irrespective of any date/s mentioned in the copy (unless otherwise advised).
- Proofs will be supplied only when requested or at the direction of the Gazette Officer.
- No additions or amendments to material for publications will be accepted by telephone.
- Orders in Council may be lodged prior to receiving assent with the Governor's or Clerk's signature. They will only be published once approved and signed.
- Government and Outer Budget Sector Agencies please note: *See style requirements on back page.*

SPECIAL GAZETTES

Copy to: Gazette Officer
The Craftsman Press Pty. Ltd.
125 Highbury Road,
Burwood Vic 3125
Telephone: (03) 9926 1233
Facsimile: (03) 9926 1292
Email: gazette@craftpress.com.au

Advertising Rates and Payment

Private Notices

Full Page \$360.00

Payment must be received in advance with notice details.

Government and Outer Budget Sector Agencies Notices

	Typeset
Full Page	\$87.50

Note:

The after hours number for Special Gazettes is:
Telephone: 0419 327 321

SUBSCRIPTIONS AND RETAIL SALES

Copies of the Victoria Government Gazette can be purchased from The Craftsman Press Pty. Ltd. by subscription.

The Victoria Government Gazette

General and Special - \$170.00 each year

General, Special and Periodical - \$227.00 each year

Periodical - \$113.00 each year

Subscriptions are payable in advance and accepted for a period of one year. All subscriptions are on a firm basis and refunds will not be given.

All payments should be made payable to The Craftsman Press Pty. Ltd.

Subscription enquiries:

The Craftsman Press Pty. Ltd.
125 Highbury Road, Burwood Vic 3125
Telephone: (03) 9926 1233

INDEX TO PRIVATE ADVERTISERS

A	I
Aitken Walker & Strachan2283	Ingpen & Bent2286
B	L
Borchard & Moore2283	Lester Fielden & Faraone2286
D	Lombard & Associates2286
De Marco & Co.2283	M
Dobson Morrow2283	M.K. Steele & Giammario2286
Dwyer Mahon & Robertson2284	O
E	Oakleys White2286
Equity Trustees Limited2284	P
G	Perpetual Trustees Victoria Limited ...2286
Garden & Green2284	R
Gavan Duffy & King2285	Rennick & Gaynor2286
Goldsmiths2285	S
Gray Friend & Long2285	Swayn & Associates2287
H	W
Hunter Newns Howman2285	White Cleland Pty.2287
	Wills & Probate Victoria2287

PRIVATE ADVERTISEMENTS

DISSOLUTION OF PARTNERSHIP

Notice is hereby given that the partnership previously subsisting between us, the undersigned, Sally Anne Finch of Fairburns Road, Hamilton and Trevor John Campbell of 50 McConachie Street, Coleraine, trading as Arcadia Records and Tapes, at 126 Gray Street, Hamilton, carrying on business as record and compact disc retail sales has been dissolved. The business in future shall be conducted by Trevor John Campbell.

Dated 1 July 1998.

SALLY ANNE FINCH
TREVOR JOHN CAMPBELL

**ADVERTISEMENT OF APPLICATION FOR
WINDING-UP**

In the matter of Bendigo Enterprise Centre Incorporated, Registered Number A0026402W, notice is hereby given that an application for the winding-up of the abovenamed company by the Supreme Court of Victoria was on 23 July 1998 filed by Bendigo Enterprise Centre Incorporated, Registered Number A0026402W. The application is to be heard in the Fifth Court, Supreme Court, 436 Lonsdale Street, Melbourne at 10.30 am on 9 September 1998.

Any creditor or contributory of the company desiring to support or oppose the making of an order on the application may appear at the time of hearing by himself or his counsel for that purpose.

The applicant's solicitor is Beck Sheahan Quinn & Kirkham of 110 Pall Mall, Bendigo.

Note: Any person who intends to appear on the hearing of the application must serve on or send by post to the abovenamed solicitor notice in writing of that intention. The notice must state the name and address of the person or, if a firm, the name and address of the firm, and must be signed by the person or firm, or their solicitor (if any), and must be served or, if posted, must be sent by post in sufficient time to be received not later than 4.00 p.m. on 8 September 1998.

Creditors, next-of-kin or others having claims in respect of the estate of JOAN PHYLLIS LEWISOHN, in the will called

Phyllis Joan Lewisohn, late of 61 Washington Street, Toorak, in Victoria, married woman, deceased, who died on 8 May 1998 are to send particulars of their claims to the executors care of the undermentioned solicitors by 4 November 1998 after which date the executors will distribute the assets having regard only to the claims of which the executors then have notice.

AITKEN WALKER & STRACHAN, solicitors,
2nd Floor, 114 William Street, Melbourne 3000.

Creditors, next-of-kin and others having claims in respect of the estate of CLARE CONWAY, late of Unit 3, 41 Leonard Avenue, Noble Park, Victoria, home duties, deceased, who died on 9 December 1997 are required to send particulars of their claims to the executrices care of the undermentioned solicitors by 28 October 1998 after which date the executrices will distribute the assets having regard only to the claims for which notice has been received.

BORCHARD & MOORE, solicitors,
44 Douglas Street, Noble Park.

Creditors, next-of-kin or others having claims in respect of TREVOR HENRY CLAVERHOUSE-DUNDEE, late of 45 West Street, Glenroy, Victoria, retired, deceased, who died on 12 July 1998 are to send particulars of their claims to the executor, care of the undermentioned solicitors, by 14 October 1998 after which date the executor will distribute the assets having regard only to the claims of which the executor then has notice.

DE MARCO & CO, solicitors,
209 Glenroy Road, Glenroy 3046.

MANKO MANCEV, late of Trentham Road, Daylesford, Victoria, deceased. Creditors, next-of-kin and others having claims in respect of the estate of the deceased, who died on 26 August 1997 and probate of whose will was granted by the Supreme Court of Victoria on 5 December 1997 to Paul Joseph Donoghue of 6 Errard Street North, Ballarat, Victoria, are to send particulars of their claims to the said executor, care of the undermentioned solicitors, by 23 October 1998, after which date

the executor will convey or distribute the assets having regard only to the claims of which he then has notice.

DOBSON MORROW,
solicitors for the executor,
14 Dawson Street South, Ballarat.

Creditors, next-of-kin or others having claims in respect of the estate of ALAN KENNETH BUCHANAN, late of Yando River Road North, Boort, farmer, deceased, who died on 27 February 1998 are to send particulars of their claims to the executors, care of the undermentioned solicitors, by 28 October 1998, after which date the executors will distribute the assets having regard only to the claims of which the executors then have notice.

DWYER MAHON & ROBERTSON, solicitors,
194-208 Beveridge Street, Swan Hill.

Creditors, next-of-kin or others having claims in respect of the estate of MARGARET GRACE GRAHAM, late of 76 Rutherford Street, Swan Hill, in the State of Victoria, widow, deceased, who died on 1 January 1998 are to send particulars of their claims to the executors, care of the undermentioned solicitors, by 23 October 1998, after which date the executors will distribute the assets having regard only to the claims of which the executors then have notice.

DWYER MAHON & ROBERTSON, solicitors,
194-208 Beveridge Street, Swan Hill.

Creditors, next-of-kin or others having claims in respect of the estate of GRAEME GEORGE EDWARD PALMER, in the will called Graeme Edward Palmer, late of Ridge Road, Woorinen, Victoria, Orchardist, deceased, who died on 5 November 1997 are to send particulars of their claims to the executors, care of the undermentioned solicitors, by 28 October 1998, after which date the executors will distribute the assets having regard only to the claims of which the executors then have notice.

DWYER MAHON & ROBERTSON, solicitors,
194-208 Beveridge Street, Swan Hill.

Creditors, next-of-kin and others having claims in respect of the estate of ANNIE ALISON CAMERON, late of Tullamore Aged Care Centre, 991 Mount Dandenong Tourist

Road, Montrose, retired nurse, deceased, who died on 30 June 1998 are to send particulars of their claims to Equity Trustees Limited, A.C.N. 004 031 298, of 472 Bourke Street, Melbourne, by 30 October 1998 after which date it will distribute the assets having regard only to the claims of which it then has notice.

Creditors, next-of-kin and others having claims in respect of the estate of DOROTHY BESSIE FIEDLER, late of Rochester and District Nursing Home, Village Drive, Rochester, retired teacher, deceased, who died on 7 July 1998 are to send particulars of their claims to Equity Trustees Limited, A.C.N. 004 031 298, of 472 Bourke Street, Melbourne, by 30 October 1998 after which date it will distribute the assets having regard only to the claims of which it then has notice.

Creditors, next-of-kin and others having claims in respect of the estate of JAMES FIREBRACE HEMPHILL, late of 135 King Road, Harkaway, retired banker, deceased, who died on 20 June 1998 are to send particulars of their claims to Equity Trustees Limited, A.C.N. 004 031 298, of 472 Bourke Street, Melbourne, by 30 October 1998 after which date it will distribute the assets having regard only to the claims of which it then has notice.

Creditors, next-of-kin and others having claims in respect of the estate of MARJORIE MILLS, late of 22/55 Highview Crescent, Macleod, widow, deceased, who died on 1 July 1998 are to send particulars of their claims to Equity Trustees Limited, A.C.N. 004 031 298, of 472 Bourke Street, Melbourne, by 30 October 1998 after which date it will distribute the assets having regard only to the claims of which it then has notice.

Creditors, next-of-kin or others having claims in respect of the estate of WILLIAM THOMAS HAWTHORN, late of Murray Valley Highway, Nyah, Victoria, farmer and contractor, deceased, who died on 13 August 1997 are to send particulars of their claims to the executors, Melva Elaine Grace Hawthorn, Wayne John Hawthorn, William Alexander Hawthorn and Robin Peter Hawthorn, care of the

undermentioned solicitors, by 14 October 1998, after which date the executors will distribute the assets having regard only to the claims of which they then have notice.

GARDEN & GREEN, lawyers,
4 McCallum Street, Swan Hill.

Creditors, next-of-kin or others having claims in respect of the estate of THOEMAS WILLIAM LAWRENCE, late of Lot 15C, Holt's Lane, Logan, Victoria, chef, deceased, who died on 22 October 1997, are to send particulars of their claims to the executor, Caroline Margaret Lawrence, care of the undermentioned solicitors, by 21 October 1998, after which date the executor will distribute the assets having regard only to the claims of which she then has notice.

GARDEN & GREEN, lawyers,
4 McCallum Street, Swan Hill.

Creditors, next-of-kin and others having claims in respect of the estate of AMY KATHERINE CALDER, late of Rumbalara Nursing Home, 171 Church Street, Brighton, widow, deceased, who died on 2 April 1998 are requested by Elizabeth Ann Linton of 2 Freemans Road, Mount Eliza, Victoria and Rosemary Margaret O'Collins of 122 Overport Road, Frankston, Victoria, the executors of the will of the deceased, to send to them, care of the undersigned solicitors, particulars thereof by 19 November 1998, after which date they will distribute the assets of the deceased having regard only to the claims of which they shall then have notice.

GAVAN DUFFY & KING, solicitors,
83 William Street, Melbourne 3000.

Creditors, next-of-kin and others having claims in respect of the estate of MARY NEWMAN, late of 16 Omeo Court, Blackburn South, Victoria, widow, deceased, who died on 22 April 1998 are requested by Paul Newman of 1/22 Walwa Street, Mitcham, Victoria, storeman, the administrator of the intestate estate of the deceased, to send to him, care of the undersigned solicitors, particulars thereof by 19 November 1998, after which date he will distribute the assets of the deceased having regard only to the claims of which he shall then have notice.

GAVAN DUFFY & KING, solicitors,
83 William Street, Melbourne 3000.

SARAH SPENCE, late of 114/29 Crown Street, Flemington, in the State of Victoria. Creditors, next-of-kin and others having claim in respect of the estate of the deceased, who died on 13 June 1998 are required by the executor, Darren Stephen Goldsmith of 54 Kerferd Street, East Malvern, in the said State, to send particulars to him care of the undermentioned solicitors, by 28 October 1998 after which date the executor may convey or distribute the assets having regard only to the claims of which he then has notice.

GOLDSMITHS, barristers & solicitors,
13 Errol Street, North Melbourne 3051.

LESLIE ROY DECKER, late of 2 McColl Street, Nilma, builder, deceased. Creditors, next-of-kin and others having claims in respect of the estate of the deceased, who died on 25 May 1998 are required by the trustee, Margaret Elaine Decker, to send particulars of their claims to her, care of the undersigned solicitors by 27 October 1998, after which date the trustee may convey or distribute the assets having regard only to the claims of which she then has notice.

GRAY FRIEND & LONG, solicitors,
70 Queen Street, Warragul 3820.

THOMAS PATRICK DENT, deceased. All persons having claims against the estate of the abovenamed deceased, late of Lewis Court, 18 Wellington Road, Portland, Victoria, who died on 29 April 1998, are hereby required to send particulars in writing of such claims to Phyllis McCaughan of 31 Walters Avenue, Niddrie, the executrix of the deceased's will at the address hereunder mentioned on or before 6 November 1998 after which date the said Phyllis McCaughan will proceed to distribute the assets of the deceased which shall have come to her hands amongst the persons entitled thereto, having regard only to the claims of which she shall then have had notice and she will not be liable for the assets distributed or any part thereof to any person of whose claim she shall not have had notice as aforesaid.

Dated 11 August 1998.

HUNTER NEWNS HOWMAN,
solicitors for the executrix,
23 Percy Street, Portland.

ARTHUR ERNEST CHANTER, late of 18 Bellevue Avenue, Highton, in the State of Victoria, gardener, deceased. Creditors, next-of-kin and others having claims in respect of the estate of the deceased, who died on 22 July, 1998 are required by the trustee, Maxwell Charles Chanter of 27 Beresford Crescent, Tullamarine, in the said State, to send particulars of their claim to the trustee, care of the undermentioned legal practitioners, by 30 November 1998, after which date the trustee may convey or distribute the assets having regard only to the claims of which he then has notice.

INGPEN & BENT, legal practitioners for the trustee, 95 Yarra Street, Geelong.

Creditors, next-of-kin or others having claims in respect of the estate of FREDERIC COLIN GROOM, late of 2 Capon Street, Chadstone, Victoria 3148, widower, deceased, who died on 3 May 1998 are to send particulars of their claims to the executors, Trust Company of Australia Limited of 151 Rathdowne Street, Carlton, Victoria 3053 and John Colin Groom of 23 Maroo Street, Oakleigh, Victoria 3166, care of the undermentioned solicitors, by 30 October 1998, after which date the executors will distribute the assets having regard only to the claims of which the executors then have notice. LESTER FIELDEN & FARAONE, solicitors, 14 Haughton Road, Oakleigh 3166.

Creditors, next-of-kin and others having claims in respect of the estate of MADGE BERNICE LOBB, deceased, who died on 28 May 1998, are required by the executor to send particulars of their claim to the undermentioned firm by 26 October 1998, after which date the trustee will convey or distribute the assets having regard only to the claims of which the trustee then has notice.

LOMBARD & ASSOCIATES, solicitors, 27 Station Road, Cheltenham.

ROBERT HENRY WILLIAMS, late of 51/339 St Helena Road, North Eltham. Creditors, next-of-kin and others having claims in respect of the estate of the deceased, who died on 12 April 1998 are required by the personal representative of the estate, Sandra Joy Brain of 78 Broadgully Road, Diamond Creek, to send

particulars to her by 31 October 1998 after which date the personal representative may convey or distribute the assets having regard only to the claims of which she then has notice. Dated 18 August 1998.

Creditors, next-of-kin or others having claims in respect of the estate of ALBERT GARDINER, late of Banksia Lodge, Station Road, Foster, Victoria, farmer, who died on 7 February 1997, are to send particulars of their claims to the executors, Adrian Morice Gardiner and Geoffrey Paul Gardiner, care of the undermentioned solicitors, by 30 October 1998, after which date the executors will distribute the assets having regard only to the claims of which notice has been received.

OAKLEYS WHITE, solicitors, 65 Main Street, Foster.

STEWART CAMERON JOY, late of 47 Brackenbury Street, Warrandyte, Victoria 3113. Creditors, next-of-kin and others having claims in respect of the estate of the deceased, who died on 24 June 1998 are required by Perpetual Trustees Victoria Limited, A.C.N. 004 027 258, of 50 Queen Street, Melbourne, to send particulars of their claims to the said company by 27 October 1998 after which date it will convey or distribute the assets having regard only to the claims of which the company then has notice.

BERYL ABI RUSSELL, late of 4 Highton Grove, Balwyn, Victoria 3103. Creditors, next-of-kin and others having claims in respect of the estate of the deceased, who died on 25 July 1998 are required by Perpetual Trustees Victoria Limited, A.C.N. 004 027 258, of 50 Queen Street, Melbourne, to send particulars of their claims to the said company by 27 October 1998 after which date it will convey or distribute the assets having regard only to the claims of which the company then has notice.

Creditors, next-of-kin and others having claims in respect of the estate of LISELOTTE PIKAS, late of Lionsbrae Hostel, 29 Everard Road, East Ringwood, Victoria, widow, deceased, who died on 28 June 1998 are to send particulars of their claims to David Anthony Rush, the executor appointed by the will, care of the undersigned by 27 October 1998 after

which date he will commence to distribute the assets having regard only to the claims of which he then has notice.

RENNICK & GAYNOR, solicitors,
431 Riversdale Road, Hawthorn East.

PETER GEORGE HUDSON, late of Unit 5, 230 Ascot Vale Road, Ascot Vale, Victoria. Creditors, next-of-kin and others having claims in respect of the estate of the deceased, who died on 2 May 1998 are required by the administrator of the deceased's estate, Leonard Slade Tainsh, of 14 Tucker Street, Horsham, Victoria, to send particulars to his lawyers, Swayn & Associates of 27-29 Roberts Avenue, Horsham, Victoria (attention: Mr S. A. Swayn) by 30 October 1998 after which date the administrator of the deceased's estate may convey or distribute the assets, having regard only to the claims of which he then has notice.

SWAYN & ASSOCIATES, lawyers,
27-29 Roberts Avenue, Horsham 3400.

Creditors, next-of-kin and others having claims in respect of the estate of KATHLEEN VERONICA GAMBLE, late of 9 Lawrey Street, Frankston, deceased, who died on 18 July 1997 are required to send particulars of their claims to the executors, William McKenzie Cleland, solicitor and Malcolm James Russell Taylor, solicitor, both of 454 Nepean Highway, Frankston, on or before 27 October 1998 after which date they will distribute the assets having regard only to the claims of which they then have notice.

WHITE CLELAND PTY, solicitors,
454 Nepean Highway, Frankston.

JUDITH ANN SANCHEZ (shown in the will as Judith Ann Camilleri) late of 10 Raith Court, St Kilda East, Victoria, auto electrician, deceased. Creditors, next-of-kin and others having claim in respect of the estate of the deceased, who died on 11 June 1998 are required to send particulars of their claims to the executors, c/- Permanent Trustee Company Limited, of 294-296 Collins Street, Melbourne, by 20 November 1998, after which date the executors may convey or distribute the assets having regard only to the claims of which they then have notice.

WILLS & PROBATE VICTORIA, lawyers,
Level 5, 360 Little Bourke Street, Melbourne.

In the Supreme Court of the State of Victoria

SALE BY THE SHERIFF

On 1 October 1998 at 2.30 p.m. at the Sheriff's Office, 8-20 King Street, Oakleigh 3166 (unless process be stayed or satisfied).

All the estate and interest (if any) of Cviko Miroslavljevic of 250 Johnstone Street, Westmeadows, proprietor of an estate in fee simple in the land described on Certificate of title Volume 7450 Folio 943 which is vacant land known as 24 Finchley Avenue, Glenroy.

Registered Mortgage No. U972822Q and Caveat No. V300680Q affect the said estate and interest.

Terms - Cash only.

SW-98-006751-0

Dated 27 August 1998.

S. BLOXIDGE
Sheriff's Office

In the Supreme Court of the State of Victoria

SALE BY THE SHERIFF

On 1 October 1998 at 2.30 p.m. at the Sheriff's Office, 8-20 King Street, Oakleigh (unless process be stayed or satisfied).

All the estate and interest (if any) of John Lanera of 61 Bishop Street, Yarraville, joint proprietor with Judy Ann Lanera of an estate in fee simple in the land described on Certificate of Title Volume 6357 Folio 390 upon which is erected a dwelling known as 61 Bishop Street, Yarraville.

Registered Mortgage No. M963955R and the covenant contained in transfer 1758666 affect the said estate and interest.

Terms - Cash only.

SW-98-007254-0

Dated 27 August 1998.

S. BLOXIDGE
Sheriff's Office

Unclaimed Moneys Act 1962

Register of Unclaimed Moneys held by the —

<i>Name of Owner on Books and Last Known Address</i>	<i>Total Amount Due to Owner</i>	<i>Description Of Unclaimed Money</i>	<i>Date when Amount first became Payable</i>
BP AUSTRALIA LIMITED			
	\$		
		Card	
Connolly Motors, 41 Bridge Street, Oakey, Qld	565.02	Settlement	20/03/96
Hogan's Axle Correction P/L, 110 Haines St, Nth Melbourne	110.00	Cheque	21/03/96
Marty Porter, C/-Food Plus Cranbourne, Shopping Centre, High Street, Cranbourne	100.00	M. Motorist	"
S. & B. Blasting Co Pty Ltd, 159 Moon Street, Moolap	1,050.00	Cheque	"
ANZ Payment Services, Finance & Accounting Dept., 570 Church Street, Richmond	2,000.00	"	18/04/96
Whitby Corner Service Station P/L, BP Mosman, Corner Avenue Road & Cowles, Mosman, NSW	223.00	Refund of CTS	23/04/96
Koolaz Refrigeration, Aircondition, P.O. Box 457, Derby, WA	192.85	Cheque	24/04/96
Leahy Petroleum Pty Ltd, Lake Bolac Agency, Glenelg Highway, Lake Bolac	320.50	Cheque	07/05/96
Leahy Petroleum Pty Ltd, Lake Bolac Agency, Glenelg Highway, Lake Bolac	4,184.65	Cheque	14/05/96
King Leopold Air, P.O. Box 78, Broome, WA	1,256.79	Settlement Payment	16/05/96
Western Power Perth, G.P.O. Box L921, Perth, WA	1,575.30	Refund	13/06/96
KlimCorp P/L, (Ex Carrara C/C)		Card	
P.O. Box 174, Ashmore City, Qld	292.38	Settlement	30/06/96
Centre for Professional Development, P.O. Box 6000, Kew	140.00	Cheque	04/07/96
Ted James Agency, 5th Floor, Office Towers, Westfield, Parramatta, NSW	400.00	Country Band	10/07/96
Neumann Petroleum, P.O. Box 6003 Tweeds Heads South, NSW	1,120.17	Card Settlement	"
M. Higginbottam, BP Surrey Downs, Golden Grove Road, Surrey Downs, SA	4,043.61	Cheque	23/07/96
ANZ Payment Services, Finance & Accounting Dept., 570 Church Street, Richmond	2,000.00	"	15/08/96
Qld Transport Brisbane, G.P.O. Box 2451, Brisbane, Qld	542.50	"	22/08/96
PPSS RL & Mr Turner, Ex Mobil Trafalgar, Princes Highway, Trafalgar	766.40	Card Settlement	31/08/96
Oustawand Pty Ltd, BP Macquarie, cnr Durham and George Streets, Bathurst, NSW	101.71	Cheque	03/10/96
Cars Trucks & Tractors Pty Ltd, P.O. Box 9, Archer Street, Woodford, Qld	1,102.42	Card Settlement	06/10/96
Frankland Roadhouse, P.O. Box 123, Frankland, WA	893.17	"	15/10/96
T. and J. K. Singh, BP Pinelands Road, 14 Sericea Street, Sunnybank Hills, Qld	7,135.20	Refund EPS Invest	22/10/96
ANZ Payment Services, Finance & Accounting Dept., 570 Church Street, Richmond	295.00	Cheque	24/10/96

Launceston City Council, St John Street, Launceston, Tas.	584.14	”	14/11/96
K. M. & A. Chadwick Travelling A/C, Kirkham Road, Bowral, NSW	275.77	Card Settlement	01/12/96
Leahy Petroleum Pty Ltd, Lake Bolac Agency, Glenelg Highway, Lake Bolac	2,125.00	Cheque	24/12/96
Avis Australia, Attn: David Van Der Hoven, P.O. Box 246, Mascot, NSW	2,000.00	Cheque	27/12/96
Dept. of Transport and Works NT Fleet, P.O. Box 69, Nhulunbuy, NT	1,046.71	Cheque	”
K. M. & A. Chadwick Travelling A/C, Kirkham Road, Bowral, NSW	283.79	Card Settlement	01/01/97
Bowan Tourist Store, 119 Herbert Street, Bowen, Qld	543.82	”	26/01/97
Anstat Pty Ltd, 224-226 Normanby Road, South Melbourne	260.00	Cheque	28/01/97
K. M. & A. Chadwick Travelling A/C, Kirkham Road, Bowral, NSW	249.60	Card Settlement	01/02/97
John Eyre Pty Ltd, Caiguna, BP John Eyre Motel 232 M/E Peg, Yere Highway, Caiguna, WA	462.55	Cheque	13/02/97
Education Department WA, 1, 151 Royal St, East Perth, WA	364.87	Refund Cheque	20/02/97
Flick Pest Control WA, P.O. Box 299, Wagin, WA	205.00	Cheque	”
Qld Transport Brisbane, G.P.O. Box 2451, Brisbane, Qld	500.00	”	”
Checkpoint Automatics Brake and Clutch WA, cnr Bannister and Vulcan Roads, Canningvale, WA	285.00	”	27/02/97
John P. Collins, Suite 32, Private Medical Centre, Royal Melbourne Hospital, Parkville	123.70	”	06/03/97
BP Edgeworth West NSW, C. & L. Stevenson, Fishing Point, NSW	453.06	”	27/03/97
Office of State Revenue, Qld, GPO Box 2476, Brisbane, Qld	9,057.00	”	”
Spectrum Management Agency NT, G.P.O. Box 2540, Darwin, NT	611.00	2-Way Radio Licence	”
Civil & Mechanical Maintenance, P.O. Box 3133, BMDC, Bassendean, WA	191.64	Refund of Cr Balance	03/04/97

98167

CONTACT: CARMELO LECCADITO, PHONE: (03) 9268 3762.

Unclaimed Moneys Act 1962

Register of Unclaimed Moneys held by the —

<i>Name of Owner on Books and Last Known Address</i>	<i>Total Amount Due to Owner</i>	<i>Description Of Unclaimed Money</i>	<i>Date when Amount first became Payable</i>
PHILIPPE BATTERS PTY LTD			
	\$		
Ms P. Olschyna, 1/6 Marne Street, South Yarra	121.22	Rent	01/04/92
Mr Watson, 6/3 Joy Street, South Yarra	578.36	”	16/06/93
Mr Rosenberg	225.00	”	16/06/94
Mr C. Nettlebeck	265.00	Refund Repairs	24/10/96

98168

CONTACT: ASHTON JAEGAR, PHONE: (03) 9867 2463.

Unclaimed Moneys Act 1962

Register of Unclaimed Moneys held by the —

<i>Name of Owner on Books and Last Known Address</i>	<i>Total Amount Due to Owner</i>	<i>Description Of Unclaimed Money</i>	<i>Date when Amount first became Payable</i>
PIVOT LIMITED A.C.N. 004 080 264			
\$			
Jeffrey Ernest Frank Ackland, "Trevlyn", Box 24, Woomelang	140.00	Cheque	21/11/96
William Herbert Aughterson & Theodore Anthony Greenland C/- J. W. Lockhart, W.S.D. Wedderburn	100.00	"	"
Graeme James Bryant, Swan Bay Road, Mannerim	100.00	"	"
Ernest Oswald Cornell & Joyce Cornell & Geoffrey Ernest Cornell & Laurence David Cornell "Laurel Hills" Condobolin, NSW	140.00	"	"
Helen May Darbyshire & William Francis Kneebone Decd RMB C 932, Jollys Hill Road, via Ballarat F W D No. 2	100.00	"	"
Mirron Ruby Grace Duff Decd & Dawn Elizabeth Bourke C/O Mrs D. E. McGregor, P.O. Box 45, Bondi Junction, NSW	120.00	"	"
John Patrick Dunne, "Blue Hills" R S D, Bridgewater	120.00	"	"
Paul William Feast, P.O. Box 202, Port Macdonnell, SA	120.00	"	"
Graeme Maxwell Gibb & Norman Alan Francis Gibb "Craigalee", P.O. Box 1175, Milawa	120.00	"	"
Owen Kingsley Harris, 6 Williams Avenue, Mildura	120.00	"	"
Raymond John Hudson, 31 Farrell Street, Ouyen	100.00	"	"
Torrie Stoddart Hunt, "Killel", P.O. Box 411, Bordertown, SA	400.00	"	"
Charles Henry Jager & Phyllis Jean Jager & Michael Jager "Devon Downs", Coldstream West Road, Lilydale	100.00	"	"
Francis Joseph Keenan & Brian Francis Keenan & James Leo Keenan & Adrian William Keenan & Jean Lillias Keenan, RMB 1945, Yarrawonga	220.00	"	"
Roderick James Macdonald, "Flowerdale" R M B 1810, Yarrawonga	100.00	"	"
Est Judith Violet Christine Manifold, Decd, "Wiridgil", Camperdown	120.00	"	"
Muriel Edna Mitchell & Trevor John Mitchell & Bruce Ronald Mitchell, Box 75, Mount Gambier, SA	120.00	"	"
Est Patrick E. Montgomery, Decd, Box 3. Frances, SA	120.00	"	"
Jillian Leonie Morutto, 45 Canberra Street, Henley Beach, SA	200.00	"	"
Est John Murray, Decd, C/- J. M. Taylor, P.O.Box 41, Edenhope	140.00	"	"
Albert Stephen Payne, R S D, Nullawarre	100.00	"	"
Peter McGregor-Reid & Victoria McGregor Reid, "Newland Park", P.O. Box 1076, Naracoorte, SA	100.00	"	"
Michelle Anne Teague, 3 King Street, Swan Hill	120.00	"	"
Charlotte Sophia Thompson, 40 Northgate Street, Mooroopna	120.00	"	"
Henry John Trainor, Decd, Mount Bute	160.00	"	"
Neville John Tranter, "She-Oak", Toolleen	120.00	"	"
The Union Fidelity Trustee Co of Australia Ltd, P.O. Box 673. Carlton South	160.00	"	"

<i>Victoria Government Gazette</i>	<i>G 34</i>	<i>27 August 1998</i>	<i>2291</i>
Clifton George Vincent, "Charlston Stud", Cooma Road, Braidwood, NSW	100.00	"	"
Alec Mario Violi, RMB 2772 Benerembah Via Griffith Est Herbert Allan Waite Decd & Allan George Waite "Boxbourne", P. B. Albury, NSW	120.00	"	"
Robert Edward Williams & Dorothy Olga Williams, Norong R S D, Springhurst	120.00	"	"
Williams Victoree Farms Pty Ltd, "Morago" R.M.B. 4100, Glenrowan	280.00	"	"

98128

CONTACT: TERRY McGRATH, PHONE: (03) 9611 5852.

Unclaimed Moneys Act 1962

Register of Unclaimed Moneys held by the —

<i>Name of Owner on Books and Last Known Address</i>	<i>Total Amount Due to Owner</i>	<i>Description Of Unclaimed Money</i>	<i>Date when first became Payable</i>
ASHTON MINING LIMITED			
	\$		
Mr Maurice Andrews, 5/3 New Beach Rd, Darling Point, NSW	160.00	Cheque	31/05/96
Mrs Kheng Choo Campbell, 32 Gul Drive, Singapore 2262	209.97	"	18/09/96
Mr William Edward Coulston 6 Karen Place, Ingleburn, NSW	131.16	"	"
John Robert Gaston, C/-Portfolio Management Performance Fund P.O. Box 55 Carlton South	111.99	"	"
G P Nominees Sdn Bhd, Level 2 Block F, North Damansara Town Centre, Damansara Heights 50490, Kuala Lumpur	287.32	"	31/05/96
G P Nominees Sdn Bhd, Level 2 Block F, North Damansara Town Centre, Damansara Heights 50490, Kuala Lumpur	430.98	"	18/09/96
M/s Lucy Kee Choon Koh, 12a Jutland Parade, Dalkeith, WA	493.76	"	31/05/96
M/s Lucy Kee Choon Koh, 12a Jutland Parade, Dalkeith, WA	740.64	"	18/09/96
Mr Khui Loong, C/- Wing On Company Limited 55 Leech Street, Ipoh Perak, West Malaysia	126.00	"	"
Mr Hamish McKellar, P.O. Box 373, Macksville, NSW	200.00	"	31/05/96
Mr Hamish McKellar, P.O. Box 373, Macksville, NSW	300.00	"	18/09/96
Mr Komene Tako, 4 Richardson Street, Boulder, WA	224.01	"	"
Mr Komene Tako, 4 Richardson Street, Boulder, WA	149.34	"	31/05/96
Mr Ratnam Thamboo, 91 Jalan Maarof Bangsar 59000 Kuala Lumpur, Malaysia	209.97	"	18/09/96
Mr Ratnam Thamboo, 91 Jalan Maarof Bangsar 59000 Kuala Lumpur, Malaysia	139.98	"	31/05/96

98129

CONTACT: TERRY McGRATH PHONE: (03) 9611 5852.

Unclaimed Moneys Act 1962

Register of Unclaimed Moneys held by the —

<i>Name of Owner on Books and Last Known Address</i>	<i>Total Amount Due to Owner</i>	<i>Description Of Unclaimed Money</i>	<i>Date when Amount first became Payable</i>
GANDEL RETAIL TRUST			
	\$		
Mr Glenn Bermingham, 6 Rowland Street, Mont Albert	393.00	Cheque	26/08/96
Mr Glenn Bermingham, 6 Rowland Street, Mont Albert	387.00	"	23/02/96
Mr Morton Browne & Mr Tony Charlton, 20 Shaftesbury Avenue, Malvern	387.00	"	23/02/96
Ms Kerry Margaret Crowley, 29 Washington Street, Upfield	198.07	"	26/08/96
Mrs Jacqueline S. Czislowski, 1/6 Grange Road, Toorak	471.60	"	"
Mr Douglas Lindsay Goodman & Mr Bruce Herbert Pascoe C/- Corrs Chambers Westgarth, G.P.O. Box 9925, Melbourne	218.23	"	"
Mr Douglas Lindsay Goodman & Mr Bruce Herbert Pascoe C/- Corrs Chambers Westgarth, G.P.O. Box 9925, Melbourne	214.90	"	23/02/96
Mr John Hamilton Gubbins, 40 Wright Street, Bentleigh	235.80	"	26/08/96
Mr Kerry Peter Jelbart C/- International Department, National Australia Bank Ltd, K.P.O. Box 691, Seoul, Korea	156.04	"	23/02/96
Mr David John B. Calvert-Jones, C/- Level 4, 111 Collins Street, Melbourne	786.00	"	26/08/96
Mr Brian O'Leary & Mrs Jeanetta O'Leary, "O'Leary Super Fund A/C", 16 Churchill Avenue, Wagga Wagga, NSW	162.10	"	"
Mr Guiseppe Scarcella, 11a Melbourne Street, Murrumbena	193.50	"	23/02/96
Mr Robert Sirgiovanni & Mrs Tina Maria Sirgiovanni, 146 Howard Road , Dingley	193.50	"	"
Mr Robert Sirgiovanni & Mrs Tina Maria Sirgiovanni, 146 Howard Road , Dingley	196.50	"	26/08/96
Mr Trevor Lane Teale, 12 Longbourne Avenue, Notting Hill	550.20	"	"
Mr Peter Edward K. Thompson, "A/C P. C. Filippe" 66 Maidstone Street, Altona	196.50	"	"
Mr Tim Weng, Unit 4, 60-66 Clarendon St, East Melbourne	232.20	"	23/02/96
Mr Tim Weng, Unit 4, 60-66 Clarendon St, East Melbourne	235.80	"	26/08/96

98132

CONTACT: TERRY McGRATH, PHONE: (03) 9611 5852.

Unclaimed Moneys Act 1962

Register of Unclaimed Moneys held by the —

<i>Name of Owner on Books and Last Known Address</i>	<i>Total Amount Due to Owner</i>	<i>Description Of Unclaimed Money</i>	<i>Date when Amount first became Payable</i>
VILLAGE ROADSHOW LIMITED			
	\$		
Mr Carl Brunskill, 5 Boundary Road, Indooroopilly, Qld	174.40	Cheque	20/11/96
Mr John Andrew Crawford & M/s Sally Jane F. Crawford #12-01, 8 Orange Grove Road, Singapore 1025	698.91	"	"
Mr Leo Francis Dingley, C/-Ernst & Young G.P.O. Box 505H, Melbourne	109.25	"	"
Mr Wayne Doran, 41 Kalang Avenue, Lenah Valley, Tas	102.00	"	"
Mr Ross Entwistle, 4/32 Williams Road, Prahran	977.23	"	"
Mr Daniel Fellman, 4 Lighthouse Street, Unit 8 Marina Del Ray, California 90292, United States	171.26	"	"
Gatalea Pty Ltd, C/-Ernst & Young Registry Services Pty Ltd G.P.O. Box 505H, Melbourne	174.40	"	"
Mr Stephen Greenwald C/-Herbst Greenwald 380 Lexington Ave, Suite 2500 New York, NY 10168-0002	151.72	"	"
Miss Natasha Alexandra Kassar, C/-Carolco Services 8800 Sunset Boulevard, Los Angeles, California, 90069 United States	722.50	"	"
Ms Adrienne Dawn Martin, C/-Ernst & Young Registry Services Pty Ltd G.P.O. Box 505H, Melbourne	204.00	"	"
Mr James Scott Milson, 9/2 Notts Avenue, Bondi, NSW	170.00	"	"
Dr A. Holyweek Sarei & M/s Claire Sarei C/-Mr Francis Seeto, 108 Flockton St, Everton Park, Qld	218.00	"	"
Ms Jane Elizabeth Sherning, C/-Ernst & Young Registry Services Pty Ltd G.P.O. Box 505H, Melbourne	218.00	"	"
Trenton Bay Pty Ltd, 45 Darling Street, South Yarra	589.95	"	"
Mr John Walsh, C/-Walsh James, 5/17 Castlereagh Street, Sydney, NSW	130.80	"	"
Mr Stuart Whitton, "Bilcrest P/L Super Fund" 48 The Drive, Bardonia, Qld	115.00	"	"

98103

CONTACT: TERRY MCGRATH, PHONE: (03) 9611 5852.

PROCLAMATIONS

**Gaming Acts (Miscellaneous Amendment)
Act 1997**

PROCLAMATION OF COMMENCEMENT

I, James Gobbo, Governor of Victoria, acting with the advice of the Executive Council and under section 2(4) of the **Gaming Acts (Miscellaneous Amendment) Act 1997**, fix 31 August 1998 as the day on which the remaining provisions of the Act, (except section 33), come into operation.

Given under my hand and the seal of
Victoria on 25 August 1998

(L.S.) JAMES GOBBO
Governor
By His Excellency's Command

ROGER M. HALLAM
Minister for Gaming

Mental Health Act 1986

PROCLAMATION OF "NEW LATROBE
REGIONAL HOSPITAL"

I, James Gobbo, Governor of Victoria, acting with the advice of the Executive Council and under section 94(1)(b) of the **Mental Health Act 1986** fix 1 September 1998 as the day on which New Latrobe Regional Hospital is to be proclaimed an approved mental health service to be known as "Gippsland Psychiatric Services".

Given under my hand and the seal of
Victoria on 25 August 1998

(L.S.) JAMES GOBBO
Governor
By His Excellency's Command

ROB KNOWLES
Minister for Health

**GOVERNMENT AND OUTER BUDGET SECTOR AGENCIES
NOTICES**

BAYSIDE CITY COUNCIL
Road Discontinuance

Under Section 206 and Schedule 10, Clause 3 of the **Local Government Act 1989** the Bayside City Council ("Council") at its ordinary meeting on 10 August 1998 formed the opinion that the part of the road shown "hatched" on the plan below is not reasonably required as a road for public use.

Council resolved to discontinue the road and transfer the land from the road to an abutting owner subject to any right, power or interest held by Council and South East Water in the road in connection with any sewers, drains, pipes, wires or cables under the control of these authorities in or near the road.

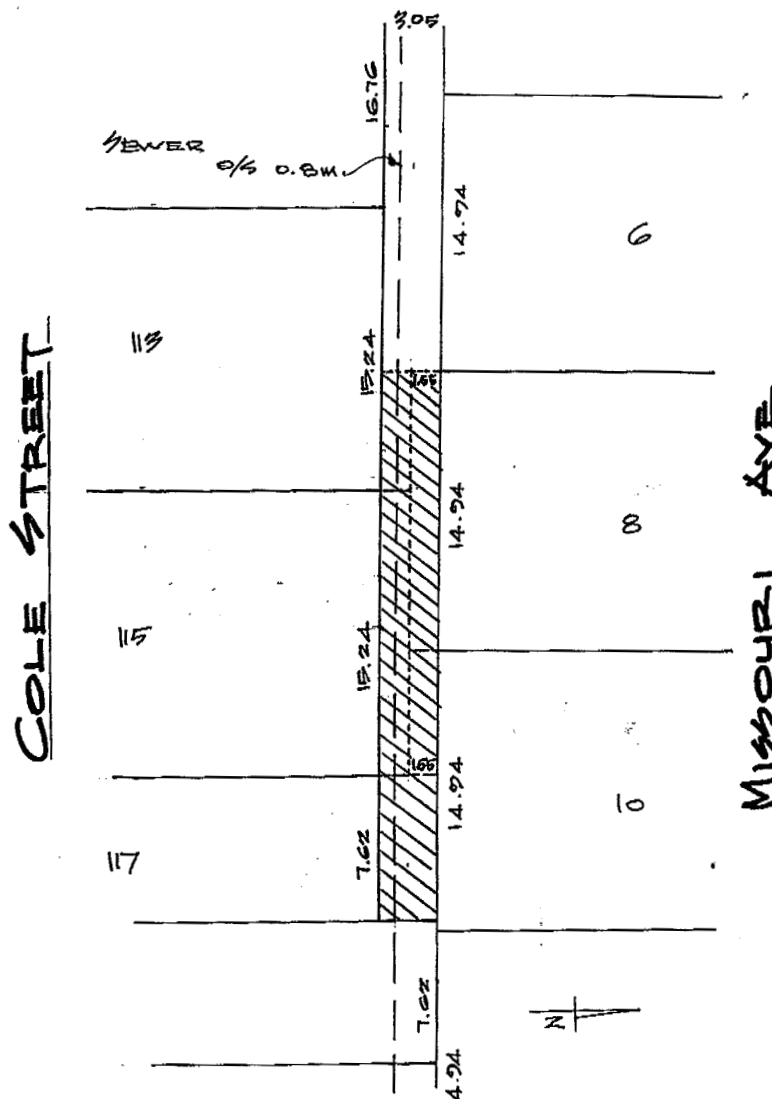

P. A. AKERS
Chief Executive Officer

MOONEE VALLEY CITY COUNCIL
Road Discontinuance

Under Section 206 and Schedule 10 Clause 3 to the **Local Government Act 1989**, the Moonee Valley City Council at its Ordinary meeting held on 18 August 1998, formed the opinion that the road shown on the plan below is not reasonably required as a road for public use and has resolved to discontinue the road and to sell the land from the road by private treaty.

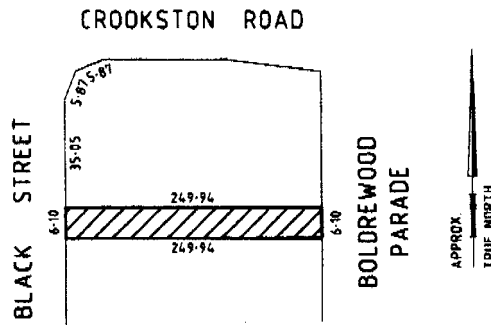

KELVIN SPILLER
Chief Executive

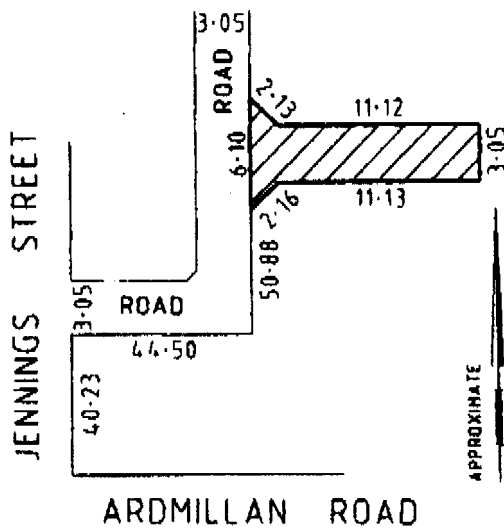

LINDSAY A. MERRITT
Chief Executive

DAREBIN CITY COUNCIL
Road Discontinuance

Under Section 206 and Schedule 10 Clause 3 of the **Local Government Act 1989** the Darebin City Council at its Ordinary meeting held on 4 August 1997, formed the opinion that the road shown on the plan below is not reasonably required as a road for public use and resolved to discontinue the road and to sell the land from the road to abutting owners subject to any right, power or interest held by the Darebin City Council and the Melbourne Water Corporation (Yarra Valley Water Ltd) in the road in connection with any sewers, drains and pipes under the control of those authorities in or near the road.

MONASH CITY COUNCIL
Road Discontinuance

At its meeting on 9 June 1998 and acting under Clause 3 of Schedule 10 to the **Local Government Act 1989**, Monash City Council ("Council"):

1. formed the opinion that the part of road shown hatched on the plan below ("the road") is not reasonably required as a road for public use; and
2. resolved to discontinue the road.

HIGH STREET ROAD

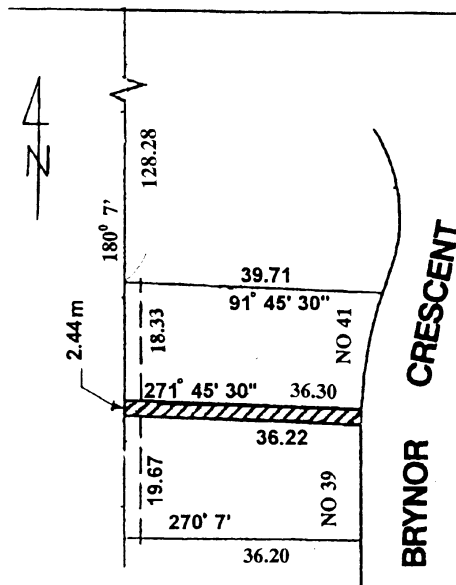

DAVID CONRAN
Chief Executive Officer

SOUTH GIPPSLAND SHIRE COUNCIL
Proposed Local Law No. 5
Amendment No. 1
Municipal Places Local Law

Notice is hereby given that at a meeting of the Council of the South Gippsland Shire held on the 11 August 1998, Council resolved to propose to make a local law titled Municipal Places Local Law (Amendment No. 1) Local Law No. 5 pursuant to the provisions of the **Local Government Act 1989**.

The objective of this local law is as follows:

To amend the Municipal Places Local Law No. 5 to recognise the Royal Life Saving Society Guidelines for Safe Pool Operation.

A copy of the local law can be obtained free of charge from the Shire Offices, Smith Street, Leongatha, during office hours from 8.00 a.m. to 5.00 p.m. Monday to Friday.

Written submissions relating to the proposed local law by any person affected by it may be made under Section 223 of the **Local Government Act 1989** and must be received by the Council within 14 days of publication of this notice.

Any written submissions should be addressed to the South Gippsland Shire Council, Private Bag 4, Leongatha 3953.

PETER TATTERSON
Chief Executive Officer



Public Holiday Act 1993

Council of the Shire of Campaspe hereby gives notice that it has appointed Tuesday November 3, 1998 a bank holiday throughout its municipal district.

GERARD JOSE
Acting Chief Executive Officer

Planning and Environment Act 1987
YARRA RANGES PLANNING SCHEME –
LOCAL SECTION
Chapter 2 (Lilydale District)
Notice of Amendment
Amendment L97

The Council of the Shire of Yarra Ranges has prepared an amendment, Amendment L97, to the Yarra Ranges Planning Scheme – Local Section – Chapter 2 (Lilydale District).

The Amendment proposes to change the planning scheme to provide discretion for Council to permit a place of worship to be established on land occupied by the Melba Centre at 71 Monbulk Road, Mt Evelyn.

Submissions

The Amendment can be inspected free of charge during normal office hours at the following Yarra Ranges Service Centres:

Lilydale: Anderson Street, Lilydale.
Monbulk: 94 Main Street, Monbulk.
Healesville: 276 Maroondah Highway, Healesville.
Upwey: 40 Main Street, Upwey.
Yarra Junction: Warburton Highway/Hoddle Street, Yarra Junction. and at: Department of Infrastructure, Office of Planning and Heritage, Level 3 Plaza, Nauru House, 80 Collins Street, Melbourne.

Any submissions about the Amendment must:

- Be made in writing, giving the submitter's name, address and, if practicable, a phone number for contact during office hours.
- Set out the views on the Amendment, that the submitter wishes to put before Council and indicate what changes (if any) the submitter wishes made to the amendment.
- State whether the person/s making the submission/s wishes to be heard in support of their submission.

Submissions must be sent to Mr Eric Howard, Chief Executive Officer, Shire of Yarra Ranges, PO Box 105 Lilydale, 3140 and must reach the Shire at the above address by 28 September 1998.

Enquiries about the Amendment can either be made by calling at the Land Use Strategy & Services Unit, Lilydale Office, Anderson Street, Lilydale, during normal office hours; or by telephoning Graham Bower, on (03) 9294 6173.

GRAHAM WHITT
Manager Land Use Strategy & Services

Planning and Environment Act 1987**BAYSIDE PLANNING SCHEME**

Notice of Amendment

Amendment L16

Bayside City Council has prepared Amendment L16 to the Bayside Planning Scheme.

The Amendment affects land at Nos. 2, 4, 24-30, 32-36, 40-46, 220-226, 228, 230, 232, 234, 236, 238-240, 242-244, 246-248, 250, 252 and 254 The Esplanade, Brighton and 2 Grosvenor Street, Brighton.

The Amendment proposes to change the Planning Scheme by deleting Clause 112-10 which allows the land at No. 24 The Esplanade, Brighton to have buildings and works constructed to a maximum height of 12 metres within 48 metres of the frontage if the land is only used for flats. The Amendment also proposes to delete Clause 112-3 of the Planning Scheme, which allows land within the Foreshore Commercial and Residential Zone to be developed with buildings exceeding two-stories in height, subject to the issue of a Planning Permit. The height limits provided under Clause 131, Height Control Area HC77 will apply to the land.

The Amendment can be inspected at: Bayside City Council, Municipal Offices, Royal Avenue, Sandringham, Vic. 3191; Department of Infrastructure, Customer Service Centre, Upper Plaza, Nauru House, 80 Collins Street, Melbourne, Vic. 3000.

Submissions about the Amendment must be sent to: Bayside City Council, P.O. Box 27, Sandringham, Vic. 3191 by 28 September 1998 - 5.00 p.m.

MICHAEL TOP
Development Manager

Planning and Environment Act 1987**GREATER GEELONG PLANNING SCHEME**

Notice of Amendment

Amendment RL185

The City of Greater Geelong has prepared Amendment RL185 to the Greater Geelong Planning Scheme.

The Amendment proposes to amend the Regional/Local Section of the Greater Geelong

Planning Scheme to enable the acquisition of approximately 3800 square metres of land at 44 – 48 Andersons Road, Drysdale, to provide for the construction of a pedestrian accessway between the Lake Lorne Recreation Reserve and the Bellarine Sub-Regional Centre.

The Amendment can be inspected at: City of Greater Geelong, 2nd Floor, 103 Corio Street, Geelong; City of Greater Geelong, Drysdale Customer Service, 18 – 20 Hancock Street, Drysdale; Department of Infrastructure, Planning Group, 63 McKillop Street, Geelong, Department of Infrastructure, Level 3 Plaza, Nauru House, 80 Collins Street, Melbourne.

Submissions about the Amendment must be sent to the Integrated Planning Unit, City of Greater Geelong, P.O. Box 104, Geelong 3220, by Monday, 28 September 1998.

CHUBB FADGYAS
Co-Ordinator City & Regional Planning

Planning and Environment Act 1987**HEPBURN PLANNING SCHEME**

Notice of Amendment

Amendment L6

The Hepburn Shire Council has prepared Amendment L6 to the Hepburn Planning Scheme, Local Section - Chapter 3.

The Amendment affects land at Crown Allotments 25, 26, 27 and 28, Section B, Parish of Smeaton (Foleys Road, Clunes).

This Amendment proposes to change the Planning Scheme by altering the zoning of the land from Rural (General Farming) Zone to Existing Public Purpose (Central Highlands Water Authority), with underlying zoning of Rural Zone. The Amendment is to facilitate the acquisition and use of the site for the establishment of the proposed Clunes wastewater (sewerage) treatment plant and associated facilities for Central Highlands Water Authority.

The Amendment can be inspected at: Hepburn Shire Council, Vincent Street, Daylesford; Department of Infrastructure (Planning Group), 477 Collins Street, Melbourne; Department of Infrastructure (Planning Group), 1315 Sturt Street, Ballarat.

Submissions about the Amendment must be sent to the Chief Executive Officer, Hepburn Shire Council, P.O. Box 21, Daylesford 3460 by September 18, 1998, indicating whether you wish to be heard in respect of the submission.

Dated 18 August 1998.

CON TSOUROUNAKIS
Manager Planning

Planning and Environment Act 1987
MAROONDAH PLANNING SCHEME

Notice of Amendment

Amendment L24

Maroondah City Council has prepared Amendment L24 to the Maroondah Planning Scheme.

This Amendment affects three (3) parcels of Council owned land. One site is a portion of an open space reserve in Highland Avenue, Croydon, that has been determined to be surplus to the needs of the Maroondah Open Space network. The other two properties are currently used for the purposes of a former caretakers dwelling at the Ringwood Golf Course in Canterbury Road, Ringwood and part of the storage area associated with the Maroondah Works Depot in Henry Road, Croydon.

The Amendment proposes to rezone the portion of open space reserve from Public Open Space to Croydon Neighbourhood Residential, part of the Works Depot site from Public Purposes - Local Government to Croydon Neighbourhood Residential and the former caretakers dwelling site at Ringwood Gold Course from Public Open Space to Residential "C".

The Amendment can be inspected at: Maroondah City Council, Ringwood Office, Braeside Avenue, Ringwood or Maroondah City Council, Croydon Office, Civic Square, Croydon and the Department of Infrastructure Book Shop, 80 Collins Street, Melbourne.

Submissions about the Amendment must be sent to: Maroondah City Council, P.O. Box 156, Ringwood 3134 by Friday 25 September, 1998.

MICHAEL MARASCO
Chief Executive Officer

Planning and Environment Act 1987

MONASH PLANNING SCHEME

Notice of Amendment

Amendment L49

The City of Monash has prepared Amendment L49 to the Monash Planning Scheme.

The Amendment affects land at 2 Einstein Avenue, Mulgrave. The land is located on the east side of Einstein Avenue and has an area of approximately 1318 square metres.

The land is currently zoned POS – Public Open Space.

The Amendment proposes to rezone land from POS – Public Open Space to R1 – Residential C.

A copy of the Amendment can be inspected during office hours, free of charge, at either the: City of Monash, Civics Centre, 293 Springvale Road, Glen Waverley, or the Department of Infrastructure, Upper Plaza, Nauru House, 80 Collins Street, Melbourne.

Submission about the Amendment must be sent to the City of Monash, P.O. Box 1, Glen Waverley 3150 by 30 September 1998.

DAVID CONRAN
Chief Executive Officer

Planning and Environment Act 1987

MOONEE VALLEY PLANNING SCHEME

Notice of Amendment

Amendment L39

The Moonee Valley City Council has prepared Amendment L39 to the Local Section of the Moonee Valley Planning Scheme.

The Amendment affects land at the rear of 42 Moore Road, Airport West. The Amendment proposes to rezone the land from General Industrial zone to Restricted Business zone and includes the land to be rezoned within the area covered by a floorspace limit for shop purposes. The Amendment does not alter the retail floorspace limit applicable to the shopping centre but provides additional land on which to accommodate the existing allowance of retail floorspace.

The Amendment may be inspected at: Department of Infrastructure, Level 3 Plaza, Nauru House, 80 Collins Street, Melbourne

3000. Strategic Planning Office, City of Moonee Valley, Civic Centre, Cnr Pascoe Vale Road and Kellaway Avenue, Moonee Ponds 3039.

Any submissions about the Amendment should be in writing and must be sent to: Attention: Executive Manager – Corporate and Strategic Planning, City of Moonee Valley, GPO Box 126, Moonee Ponds 3039 by 29 September 1998.

Date: 27 August 1998

GEOFF RUNDELL
Executive Manager –
Corporate and Strategic Planning
City of Moonee Valley

PARKIN, Alastair Campbell, late of 752 Malvern Road, Armadale, retired, who died 27 June, 1998.

SEVER, Giuseppe Aldo, late of Flat 9/98 Grosvenor Street, East St. Kilda, retired, who died 29 March, 1998.

WALKER, Doris Kate, late of Thomastown Private Nursing Home, 89 Dalton Road, Thomastown, pensioner, who died 7 May, 1998.

Dated at Melbourne 20 August, 1998.

CATHY VANDERFEEN
Manager, Estate Management
State Trustees Limited

Creditors, next-of-kin and others having claims against the estate of any of the undermentioned deceased persons are required to send particulars of their claims to State Trustees Limited, A.C.N. 064 593 148, 168 Exhibition Street, Melbourne, Victoria 3000, the personal representative, on or before 29 October 1998 after which date State Trustees Limited may convey or distribute the assets having regard only to the claims of which State Trustees Limited then has notice.

BROOKS, Edmund, also known as Edmond Brooks, late of 5 Clifton Street, Carnegie, gentleman, who died 15 June, 1998.

CHILLEMI, Domenica, late of Perpetua - The Pines, 355 Springvale Road, Donvale, widow, who died 22 June, 1998.

CROOK, John, late of Wangaratta & District Nursing Home, Green Street, Wangaratta, pensioner, who died 16 June, 1998.

MORRIS, Emma Gertrude, late of Glendale Aged Care Hostel, 1 Glendale Court, Werribee, retired school teacher, who died 30 April, 1998.

NOLAN, Thomas Laurence, late of Nolans Road, Meeniyan, farmer who died 29 May, 1998.

OWEN, Thomas William, late of Unit 7, 245 Esplanade, Altona, retired, who died 27 May, 1998.

PARKER, Ivy, late of 10 Lascelles Street, Coburg, home duties, who died 7 January, 1997.

Creditors, next-of-kin and others having claims against the following estates:-

JEANNE BOWER, late of 12 Gregory Court, Indented Head, Victoria, retired, deceased, who died on 1 May 1998.

JOHAN AINT BRUEN, late of Camberwell House, 22 Stanhope Grove, Camberwell, Victoria, pensioner, deceased intestate, who died on 25 July 1998.

MARY CULKIN, late of 10 A'Beckett Street, Kew, Victoria, pensioner, deceased intestate, who died on 28 June 1998.

GORDON DOUGLAS HERBERT, late of Prague House, 52 Sackville Street, Kew, Victoria, pensioner, deceased intestate, who died on 27 June 1998.

JOHANNES GERARD JANSEN, late of 256 Douglas Parade, Newport, Victoria, pensioner, deceased, who died on 2 July 1998.

ETHEL LONG, late of Kingston Centre, Geriatric Hospital, Warrigal Road, Cheltenham, Victoria, pensioner, deceased intestate, who died on 30 May 1993.

DOREEN MARGARET LORBACH, late of 31 Michelangelo Drive, Redlynch Grove, Cairns, Queensland, pensioner, deceased, who died on 31 May 1998.

MARJORIE EVELYN NELSON, late of 38 Thomas Street, Baxter, Victoria, dressmaker, deceased, who died on 24 May 1998.

MYRTLE ROWAN, late of Western Private Nursing Home, 46 Commercial Road, Footscray, Victoria, retired, intestate, who died on 5 July 1998.

MARY JOYCE SMITH, late of North West Hospital, Poplar Road, Parkville, Victoria, pensioner, deceased, who died on 25 June 1998.

ALEX JAMES CARRSON STUART, late of Corandirk Frail Aged Hostel, 74A Maribyrnong Road, Moonee Ponds, Victoria, pensioner, deceased, who died on 5 July 1998.

Creditors, next-of-kin and others having claims against the abovementioned estates are required pursuant to Section 33 of the **Trustee Act 1958** to send particulars of their claims against the abovementioned estates to State Trustees Limited, 168 Exhibition Street, Melbourne, Victoria, on or before 29 October 1998 after which date State Trustees Limited, A.C.N. 064 593 148, may convey or distribute the assets of the abovementioned estates having regard only to the claims of which it then has notice.

Department of Treasury and Finance

SALE OF CROWN LAND
BY PUBLIC AUCTION

Auction Date: Wednesday 16 September 1998 at 1.00 p.m. on site.

Reference: 97/04293.

Address of Property: 29 Browning Street, Orbost.

Crown Description: Crown Allotment 14B, Section 10, Township & Parish of Orbost.

Terms of Sale: Deposit 10%, Balance 60 days.

Area: 1,172 m².

Officer Co-ordinating Sale: Andrew Martin, Victorian Government Property Group, Department of Treasury and Finance, 10/1 Macarthur Street, Melbourne, Vic. 3002.

Selling Agent: King & Heath First National, 125 Main Street, Bairnsdale, Vic. 3875.

ROGER M. HALLAM
Minister for Finance

Department of Treasury and Finance

SALE OF CROWN LAND
BY PUBLIC AUCTION

Reference: P201718.

Auction Date: Friday 9 October 1998 at 2.00 p.m. on site.

Property Address: Great Alpine Road, Smoko.

Crown Description: Allotment 57C, Parish of Freeburgh.

Area: 1.593 hectares.

Terms of Sale: 10% deposit, balance 60 days.

Co-ordinating Officer: Geoff Allen, Land Sales Officer, Department of Natural Resources and Environment, Wangaratta. Telephone: (03) 5720 1764.

Selling Agent: Alexander's First National Real Estate, 107 Gavan Street, Bright. Telephone: (03) 5755 1944.

ROGER M. HALLAM
Minister for Finance

NORTH EAST REGION WATER AUTHORITY
NOTICE OF MAKING BY-LAW NO. 130
Minor Trade Waste Control

At a meeting of the North East Region Water Authority held 15 July 1998, the Authority agreed to the making of By-Law No. 130 – Minor Trade Waste Control.

This By-Law makes general provisions for the discharge of Minor Trade Waste flows to the Authority's sewers and provides details of activities which may generate Minor Trade Waste flows, terms and conditions for Minor Trade Waste Agreements, charges and fees and penalties for non-compliance.

The By-Law is available for inspection during normal business hours at the offices of North East Region Water Authority, Level 3, City Offices, Hovell Street, Wodonga. Copies of the By-Law may be purchased for the sum of ten dollars (\$10.00) each.

Information regarding the making of this By-Law may be obtained by contacting Barry O'Brien, telephone (02) 6022 0560.

J. B. O'BRIEN
Secretary

Dairy Industry Act 1992
DETERMINATION

The Determination is made by the Victorian Dairy Industry Authority under the powers conferred by Section 61 of the **Dairy Industry Act 1992** and shall come into operation on 1 November 1998.

The Determination of milk prices made by the Victorian Dairy Industry Authority and published in the Government Gazette dated 16 July 1998 is revoked.

DETERMINATION

Part 1

DETERMINATION UNDER SECTION 3 OF THE DAIRY INDUSTRY ACT 1992

Export sales are sales for the purposes of human consumption as a liquid beyond the territorial limits of the Commonwealth of Australia.

Ultra Heat treated milk (UHT milk) is milk that is processed by subjecting the product to a temperature of not less than 132 degrees centigrade for not less than one second and aseptically packaging it in approved hermetically sealed packages.

Ultra Heat Treated Milk with 5% Ultra Filtered permeate added is UHT milk as defined above with 5% (by volume) of ultra filtered permeate added.

Flavoured milk is milk to which flavouring, as defined in the Food Standards Code, has been added so as to alter the odour or taste of the milk to an appreciable extent.

Concentrated skim milk and concentrated whole milk used in the manufacture of market milk is market milk.

Milk used in the production of "Vita Plus" is market milk for the purposes of the above Act.

Part 2

PRICES PAYABLE FOR MILK SUPPLIED TO PROCESSORS BY THE AUTHORITY

The Authority has determined that all milk will be sold ex factory and that the following prices must be paid for milk sold by the Authority to milk processors.

- (a) Standardised raw milk for processing as daily pasteurised milk for sale in Victoria will be:
 - (i) for flavoured milk and low fat flavoured milk marketed under processor (non VDIA) brands - 52.76 cents per litre.
 - (ii) for all other milk - 52.76 cents per litre.
- (b) Standardised raw milk for processing as daily pasteurised milk for sale in Australia but outside Victoria will be:
 - (i) for flavoured milk and low fat flavoured milk marketed under processor (non VDIA) brands - 52.01 cents per litre.
 - (ii) for all other milk - 52.01 cents per litre.
- (c) Standardised raw milk for processing as daily pasteurised milk for sale by export will be 23.88 cents per litre.
- (d) Standardised raw milk for processing as daily pasteurised ultra filtered milk for sale in Victoria will be 41.80 cents per litre.
- (e) Standardised raw milk for processing as daily pasteurised ultra filtered milk for sale in Australia but outside Victoria will be 41.32 cents per litre.
- (f) Standardised raw milk for processing as ultra heat treated milk for sale in Victoria will be:-
 - (i) for flavoured milk and low fat flavoured milk marketed under processor (non VDIA) brands - 39.57 cents per litre.
 - (ii) for all other milk - 39.57 cents per litre.
- (g) Standardised raw milk for processing as ultra heat treated milk for sale in Australia but outside Victoria will be 39.57 cents per litre.
- (h) Standardised raw milk for processing as ultra heat treated milk for sale by export will be 24.06 cents per litre.
- (i) Standardised raw milk for processing as Ultra heat treated milk with 5% ultra filtered permeate added for sale in Australia will be 39.13 cents per litre.
- (j) Standardised raw milk for processing as sterilised milk for sale by export will be 24.06 cents per litre.
- (k) Standardised raw milk for processing as daily pasteurised organic and bio-dynamic milk for sale in Victoria will be 56.46 cents per litre.
- (l) Standardised raw milk for processing as daily pasteurised organic and bio-dynamic milk for sale in Australia but outside Victoria will be 55.62 cents per litre.
- (m) Standardised raw milk for processing as concentrated skim milk for use to adjust the solids content in market milk for sale in Victoria will be 33.91 cents per litre.

- (n) Standardised raw milk for processing as concentrated skim milk for use to adjust the solids content in market milk for sale in Australia but outside Victoria will be 33.72 cents per litre.

TOM AUSTIN
Chairman

Co-operatives Act 1996
GLEN KATHERINE PRIMARY
CO-OPERATIVE LTD
SPRINGVALE SPORTS CLUB
CO-OPERATIVE LIMITED
WEDGE PARK PRIMARY SCHOOL
CO-OPERATIVE LTD

Notice is hereby given in pursuance of Section 316(1) of the **Co-operatives Act 1996** and Section 572(2) of the **Corporations Act 1989** that, at the expiration of three months from the date hereof, the names of the aforementioned Co-operatives will, unless cause is shown to the contrary, be struck off the register and the Co-operatives will be dissolved.
Dated at Melbourne 17 August 1998.

PAUL HOPKINS
Deputy Registrar of Co-operatives

Livestock Disease Control Act 1994
APPOINTMENT OF INSPECTOR

I, John William Galvin, Manager Animal Health Operations, Position Number 230599, in the Department of Natural Resources and Environment, pursuant to the powers, duties and functions given to me by a delegation under section 103 of the **Livestock Disease Control Act 1994** and my respective powers to appoint inspectors under section 108 of the **Livestock Disease Control Act 1994**, **HEREBY APPOINT** the following officer, who holds a position under the provisions of the **Public Sector Management Act 1992**, as inspector for the purposes of all or any of the provisions of the **Livestock Disease Control Act 1994** and in respect of all or any livestock other than for fish and bees.

Name of Officer	Position of Officer
Andrew Keith Cameron	231773

Dated 7 August 1998.

JOHN WILLIAM GALVIN
Manager Animal Health Operations

Prevention of Cruelty to Animals Act 1986
APPROVAL OF INSPECTOR

I, Peter John Bailey, Director Quality Assurance, Position Number 212677, in the Department of Natural Resources and Environment, pursuant to the powers, duties and functions given to me by a delegation under section 38 of the **Prevention of Cruelty to Animals Act 1986** and of my respective powers to approve inspectors under section 18 of the **Prevention of Cruelty to Animals Act 1986**, **HEREBY APPROVE** the following officer, who is an inspector of livestock under the provisions of the **Livestock Disease Control Act 1994**, as inspector for the purposes of Part 2 of the **Prevention of Cruelty to Animals Act 1986**.

Name of Officer	Position of Officer
Andrew Keith Cameron	231773

Dated 10 August 1998.

PETER JOHN BAILEY
Director Quality Assurance



Heritage
VICTORIA

Heritage Act 1995
NOTICE OF REGISTRATION

As Executive Director for the purpose of the Heritage Act, I give notice under section 46 that the Victorian Heritage Register is amended in that the Heritage Register Number 1725 in the category described as a Heritage place is now described as:

North West Hospital, Parkville Campus (formerly Mount Royal Hospital), Poplar Road, Parkville, City of Melbourne.

EXTENT:

1. To the extent of all the buildings known as former Industrial School (B-1), Kiosk and Concert Hall (B-2), former Women's Division (B-3), former Nurses' Home (B-4), Chapel (B-5), Timber Garden Structure (B-6) and Timber Shed (B-7) on Diagram 603562 held by the Executive Director.

2. To the extent of all the land marked L-1 on Diagram 603562 held by the Executive Director,

being part of the land described as Reserve 9297, Allotment 3A, 3B and 3C, Section 99A, Royal Park, Parish of Jika Jika.

Dated 16 July 1998.

RAY TONKIN
Executive Director

Optometrists Registration Act 1996
OPTOMETRISTS REGISTRATION BOARD
OF VICTORIA
Fees Payable to the Board

In accordance with Section 90(1)(c) of the **Optometrists Registration Act 1996** the Board has fixed the following fees which will be payable to the Board from 1 December 1998:

Section of Act	Fee	Amount \$
5(2)(b)	Registration	235
8	Specific registration	235
11(3)(b)	Endorsement of registration	102
13(1)(b)	Renewal of registration	219
13(2)	Late payment fee	51
14(b)	Restoration of registration	291
17(5)	Copy of register	51
17(5)	Extract from register	5

Dated 18 August 1998.

J. G. BARKLA
Registrar

Prostitution Control Act 1994
APPLICATION PURSUANT TO SECTION
84 OF THE PROSTITUTION CONTROL
ACT TO RESCIND ORDER

Haderbret Nominees Pty Ltd: Applicant.

Allan Sterck: Respondent.

Take notice that in the Prahran Magistrates Court on 19/8/98 the following order was made:-

Order that the declaration made on 18 June 1998 in respect of the premises situated at 265 Glenferrie Road, Malvern (the premises) be rescinded on condition that upto the 18th day of December 1998 the owner of the premises Haderbret Nominees Pty Ltd, not knowingly let or use or permit to be used the first floor of the premises for the purpose of a brothel, massage parlour, relaxation centre, therapeutic centre or any similar purpose.

By the Court.

A. J. CALDWELL
Registrar, Magistrates Court of Victoria

Stamps Act 1958

NOTICE UNDER SECTION 40A

Pursuant to section 40A of the **Stamps Act 1958** I hereby declare:

AP-347 COMPANIES EXPRESS PTY LTD

to be an "Authorised Persons" effective from 17 August, 1998 in relation to the stamping of Instruments of Settlement.

Dated 17 August 1998.

DAVID POLLARD
Commissioner of State Revenue.

Stamps Act 1958

NOTICE UNDER SECTION 40A

Pursuant to section 40A of the **Stamps Act 1958** I hereby declare:

AP-367 RUTHERFORD & CO

to be an "Authorised Persons" effective from 20 August, 1998 in relation to the stamping of Leases, Agreements to Lease and Assignments or Transfers of Lease.

Dated 20 August 1998.

DAVID POLLARD
Commissioner of State Revenue.

Transport Act 1983

TOW TRUCK DIRECTORATE OF
VICTORIA

Tow Truck Applications

Notice is hereby given that the following application will be considered by the Licensing Authority after 30 September 1998.

Notice of any objection to the granting of an application should be forwarded to reach the Director, Tow Truck Directorate of Victoria, Level 6, 14-20 Blackwood Street, North Melbourne (P.O. Box 666, North Melbourne 3051) not later than 24 September 1998.

It will not be necessary for interested parties to appear on the date specified, unless advised in writing.

Goldring Constructions Pty Ltd. Application for variation of conditions of tow truck licence number TOW489 which authorise the licensed vehicle to be managed, controlled and operated from a depot situated at 1903 Frankston-Flinders Road, Hastings to change the depot address to 2089 Frankston-Flinders Road, Hastings.

Dated 27 August 1998

TERRY O'KEEFE
Director

Children's Services Act 1996

I, Heather Butow, Assistant Director, Office of the Family, hereby approve each of the qualifications contained in the attached schedule under Regulation 25(a) of the Children's Services Regulations 1998.

HEATHER BUTOW
Assistant Director, Office of the Family

List of Early Childhood Qualifications - Victoria - Children's Services Regulations 1998

Name of Institution	Name of Qualification
Victoria	
University of Melbourne (formerly Melbourne College of Advanced Education, Institute of Early Childhood Development; State College of Victoria, Melbourne Kindergarten Teachers' College, Kindergarten Training College)	Bachelor of Early Childhood Studies Bachelor of Education (Early Childhood) Diploma of Teaching (Early Childhood) Diploma of Melbourne Kindergarten Teachers' College Diploma of Kindergarten Training College Diploma of Child Care Services Associate Diploma in Social Science (Child Care) Associate Diploma in Arts (Child Care) Associate Diploma in Child Care
Monash University (formerly Chisholm Institute of Technology, State College of Victoria at Frankston)	Bachelor of Education (Early Childhood) Graduate Diploma in Children's Services Bachelor of Teaching (Early Childhood) Diploma of Teaching (Early Childhood)
Royal Melbourne Institute of Technology (formerly Phillip Institute of Technology, State College of Victoria at Coburg)	Bachelor of Education (Early Childhood Education) Graduate Certificate in Early Childhood Teaching Graduate Diploma in Early Childhood Teaching Diploma of Teaching (Early Childhood Education) Diploma of Teaching (Early Childhood Education) with Advanced Standing Bachelor of Teaching (Early Childhood Education) Bachelor of Teaching (Early Childhood Education) with Advanced Standing Graduate Diploma in Early Childhood Education
Acacia College Community Child Care Association	Diploma of Community Services (Child Care)
Bendigo Regional Institute of TAFE Box Hill Institute of TAFE Casey Institute of TAFE Central Gippsland Institute of TAFE East Gippsland Institute of TAFE Gordon Institute of TAFE (formerly Gordon Technical College) Goulburn Valley Institute of TAFE	Diploma of Children's Services (Centre Based Care) Diploma of Community Services (Child Care) Diploma of Children's Services (Centre Based Care) Associate Diploma of Social Science (Child Care) Associate Diploma of Social Science (Child Care Studies)

Name of Institution	Name of Qualification
Victoria (continued)	
Holmesglen Institute of TAFE (formerly Holmesglen College of TAFE) Kangan Institute of TAFE Northern Melbourne Institute of TAFE Outer Eastern Institute of TAFE Peninsula Institute of TAFE (formerly Frankston College of TAFE) School of Mines and Industries Ballarat (formerly Ballarat School of Mines) Sunraysia Institute of TAFE Swinburne University of Technology (formerly Prahran College of TAFE) Victoria University of Technology Western Melbourne Institute of TAFE Wimmera Institute of TAFE Wodonga Institute of TAFE	
New South Wales	
Sydney Catholic Training College	Diploma of Teaching (Early Childhood)
Wollongong Training College	Diploma of Teaching (Early Childhood)
Hunter Institute of Higher Education	Bachelor of Education (Early Childhood) Diploma of Teaching (Early Childhood)
Riverina-Murray Institute of Higher Education	Bachelor of Education (Early Childhood)
Macarthur Institute of Higher Education	Bachelor of Education (Early Childhood) Diploma of Teaching (Early Childhood)
Kuring-gai College of Advanced Education	Diploma of Teaching with Specialisation in Early Childhood Education
Mitchell College of Advanced Education	Diploma of Teaching (Early Childhood)
Nepean College of Advanced Education	Diploma of Teaching (Early Childhood)
Newcastle College of Advanced Education	Diploma of Teaching (Early Childhood)
Riverina College of Advanced Education	Diploma of Teaching (Early Childhood)
Charles Sturt University	Bachelor of Education (Early Childhood) Diploma of Teaching (Early Childhood) Bachelor of Teaching (Early Childhood)
Macquarie University (formerly Nursery School Teachers' College, Sydney Kindergarten Teachers' College,	Graduate Diploma in Education (Early Childhood) Bachelor of Education (Early Childhood) Bachelor of Teaching (Early Childhood)

Name of Institution	Name of Qualification
New South Wales (continued)	
Institute of Early Childhood Studies; Sydney College of Advanced Education)	Diploma of Teaching (Early Childhood) Diploma of Sydney Kindergarten Teachers' College Diploma of Sydney Nursery School Teachers' College
University of Newcastle	Bachelor of Education (Early Childhood) Diploma of Teaching (Early Childhood)
Sydney University	Diploma of Teaching (Early Childhood)
University of Western Sydney	Bachelor of Education (Early Childhood) Bachelor of Teaching (Early Childhood) Diploma of Teaching (Early Childhood)
University of Wollongong	Bachelor of Education (Early Childhood) Diploma of Teaching (Early Childhood)
Armidale TAFE College Bankstown TAFE College Belmont TAFE College Coffs Harbour TAFE College Crows Nest TAFE College Goulburn TAFE College Lismore TAFE College Liverpool TAFE College Loftus TAFE College Macksville TAFE College Meadowbank TAFE College Moss Vale TAFE College Nowra TAFE College Orange TAFE College OTEN TAFE College Petersham TAFE College Randwick TAFE College Taree TAFE College Wagga Wagga TAFE College Werrington TAFE College Wollongong TAFE College Wyong TAFE College	Associate Diploma in Social Science (Child Studies) Associate Diploma in Social Science (Child Care)
Queensland	
Queensland University of Technology (formerly North Brisbane College of Advanced Education, Brisbane College of	Diploma of Teaching (Primary and Preschool) Diploma of Teaching (Primary with major/ specialisation in Early Childhood Education)

Name of Institution	Name of Qualification
Queensland (continued)	
Advanced Education: Carseldine Campus/Kelvin Grove Campus/Kedron Park Campus, Brisbane College of Advanced Education: School of Early Childhood Studies, Brisbane Kindergarten Teachers' College, Carseldine Campus/Kelvin Grove Campus/Kedron Park Campus, Kedron Park Teachers College)	Diploma of Teaching (Primary and Early Childhood Education) Diploma of Teaching (Early Childhood Education) Diploma of the Brisbane Kindergarten Teachers' College Associate Diploma of Child Care Bachelor of Education (Preservice) Early Childhood ED52 Bachelor of Education (Preservice Early Childhood) External ED53 Bachelor of Teaching (Early Childhood)
Central Queensland University (formerly University of Central Queensland)	Bachelor of Education -Early Childhood Studies Studies (Preservice) Bachelor of Teaching (Early Childhood Studies) Bachelor of Teaching with major/specialisation in Early Childhood Education Diploma of Teaching with major/specialisation in Early Childhood Education
James Cook University: North Queensland	Bachelor of Education (Early Childhood Education) Diploma of Teaching (Early Childhood Education) Postgraduate Diploma in Education (Early Childhood)
University of Southern Queensland (formerly Darling Downs Institute College of Advanced Education)	Bachelor of Teaching with major/specialisation in Early Childhood Education Diploma of Teaching (Primary) with major/specialisation in Early Childhood Education
Australian Catholic University: McAuley Campus	Bachelor of Teaching (Primary) with specialisation in Early Childhood
Griffith University: Nathan Campus (formerly Mt Gravatt College of Advanced Education, Brisbane College of Advanced Education)	Diploma of Teaching (Primary) with major/specialisation in Early Childhood Education Bachelor of Teaching with major/specialisation in Early Childhood Education
ABC Early Childhood Training College	Diploma of Child Care and Education
Queensland Open Learning Institute TAFE College (formerly Queensland Distance Education College/Centre)	Associate Diploma of Education (Child Care) CND 35 Diploma of Child Care and Education CNO325
Bayside TAFE College Bundaberg TAFE College Cairns TAFE College Gold Coast TAFE College	Associate Diploma of Education (Child Care) CND 35 Diploma of Child Care and Education CNO325

Name of Institution	Name of Qualification
Queensland (continued)	
Ipswich TAFE College Kangaroo Point TAFE College Logan TAFE College Mackay TAFE College Maryborough TAFE College Mt Isa TAFE College North Point TAFE College Rockhampton TAFE College South Coast TAFE College Toowoomba TAFE College Townsville TAFE College	
South Australia	
Hartley College of Advanced Education	Bachelor of Education (Early Childhood) Diploma of Teaching (Early Childhood) Graduate Diploma in Education (Early Childhood)
Kingston College of Advanced Education	Diploma of Teaching (Early Childhood) Graduate Diploma in Education (Early Childhood)
South Australian College of Advanced Education	Bachelor of Education (Early Childhood) Bachelor of Teaching (Early Childhood Education) Diploma of Teaching (Early Childhood) Graduate Diploma in Education (Early Childhood)
University of South Australia	Bachelor of Early Childhood Education Bachelor of Education (Early Childhood Education) Bachelor of Teaching (Early Childhood Education) Bachelor of Social Science (Human Services) Child Care
Adelaide Institute of TAFE Croydon Institute of TAFE Onkaparinga Institute of TAFE Para Institute of TAFE Spencer Institute of TAFE Torrens Valley Institute of TAFE	Diploma of Community Services (Child Care) Associate Diploma in Child Care
Pam Arnold Centre	Associate Diploma in Social Science (Child Care) Diploma in Child Care

Name of Institution	Name of Qualification
Western Australia	
Meerilinga Teachers' College	Diploma of Teaching (Early Childhood)
Kindergarten Training College	Diploma of Kindergarten Teaching
Curtin University (formerly Western Australian Institute of Technology)	Bachelor of Education (Early Childhood) Bachelor of Arts (Education) (Early Childhood) Diploma of Teaching (Early Childhood) Associate Diploma in Arts (Child Care)
Edith Cowan University (formerly Mount Lawley Teachers' College, Churchlands Teachers' College, West Australian College of Advanced Education)	Bachelor of Education (Early Childhood) Bachelor of Arts Education (Early Childhood Education) Associate Diploma of Social Science (Child Care) Graduate Diploma of Social Science (Children's Studies) Bachelor of Social Science (Family & Children's Studies) Bachelor of Social Science (Children's Studies)
University of Notre Dame	Graduate Diploma in Education (Early Childhood) Graduate Certificate in Education (Early Childhood)
Geraldton TAFE Midland TAFE Perth TAFE South West Regional TAFE Great Southern Regional TAFE South East Metropolitan TAFE Fremantle TAFE	Diploma in Children's Services Associate Diploma of Social Science (Child Care)
Tasmania	
Launceston Teachers' College	Diploma of Teaching (Early Childhood)
Hobart Teachers' College	Diploma of Teaching (Early Childhood)
Tasmanian State Institute of Technology	Bachelor of Education (Early Childhood) Graduate Diploma of Education (Early Childhood) Diploma of Teaching (Early Childhood)
Tasmanian College of Advanced Education	Bachelor of Education (Early Childhood) Diploma of Teaching (Early Childhood)
Mount Nelson College of Advanced Education	Bachelor of Education (Early Childhood) Diploma of Teaching (Early Childhood)
University of Tasmania	Bachelor of Education (Early Childhood) Diploma of Teaching (Early Childhood)

Name of Institution	Name of Qualification
Tasmania (continued)	
	Diploma of Education (Early Childhood Education) Graduate Diploma of Education (Early Childhood)
Hobart TAFE College Launceston TAFE College North West TAFE College	Associate Diploma in Social Science (Child Care)
Australian Capital Territory	
University of Canberra (formerly Canberra College of Advanced Education)	Bachelor of Education (Early Childhood) Diploma of Teaching (Early Childhood Education)
Canberra Institute of Technology (formerly Canberra College of TAFE)	Diploma of Community Services (Child Care) Associate Diploma of Social Science (Child Care) Associate Diploma in Child Care Studies Associate Diploma in Applied Science (Child Care Studies)
Northern Territory	
Northern Territory University	Bachelor of Teaching (Early Childhood) Diploma of Teaching (Early Childhood Education) Associate Diploma in Child Care Studies Associate Diploma in Education (Child Care)
Batchelor College	Diploma of Teaching (Early Childhood Education)
Darwin Community College	Certificate in Child Care Studies
Batchelor College of Advanced Education	Associate Diploma in Education (Early Childhood)
Alice Springs (Centralian) TAFE (formerly Alice Springs Community College)	Associate Diploma in Education (Child Care)
Katherine TAFE	Associate Diploma in Education (Child Care)

Private Agents Act 1966

NOTICE OF RECEIPT OF APPLICATIONS FOR LICENCES UNDER THE PROVISIONS OF
THE **PRIVATE AGENTS ACT 1966**

I, the undersigned, being the Deputy Registrar of the Melbourne Magistrates' Court hereby give notice that applications, as under, have been lodged for hearing by the said Court on the date specified.

Any person desiring to object to any of such application must:

- (a) lodge with me a notice in the prescribed form of his objection and of the grounds thereof;
- (b) cause a copy of such notice to be served personally or by post upon the applicant at least three days before the hearing of the application; and

- (c) send or deliver-
- (i) where the objection is not made by the officer in charge of the police district in which the Court is situated — a copy of the notice to such officer; and
 - (ii) where the objection is not made by the Registrar or Deputy Registrar — a copy to the Registrar.

<i>Full name of Applicant or in the case of a Firm or Corporation, of the Nominee</i>	<i>Place of Abode of Applicant or Nominee</i>	<i>Name of Firm or Corporation</i>	<i>Address for Registration</i>	<i>Type of Licence</i>	<i>Date of Hearing of Application</i>
Noel John Wyett	16 Newstead Way, Wantirna South, 3152	Tekitu Pty Ltd	1/490 Bourke Street, Melbourne	Commercial agents	
Peter Edward Carew	20 Fermanagh Road, Camberwell	Incorp Pty Ltd	Level 13, 570 Bourke Street Melbourne	Commercial agent	
Linda Anne Hemphill	16-18 Maltravers Road, Ivanhoe 3079	Eagle Legal	Room 201, Equity Chambers, 472 Bourke Street, Melbourne	Commercial agent	

Dated at Melbourne 27 August 1998.

PETER MITHEN
Deputy Registrar Melbourne Magistrates' Court

Melbourne and Metropolitan Board of Works Act 1958

NOTICE OF DETERMINATION

In accordance with Section 239B (1AA)-(1AC) of the **Melbourne and Metropolitan Board of Works Act 1958** and with Section 139 (3A) - (3C) of the **Water Industry Act 1994** inserted by the **Water Industry (Amendment) Act 1995**, the Valuer General has determined the following valuation equalisation factors. These factors, by which in the opinion of the Valuer General, the net annual value of land within the specified area or postcode determined, as at the nominated prescribed date, ought to be multiplied if the net annual value the land is to accord with levels of value generally prevailing in that area as at 30 June 1990.

<i>Postcode</i>	<i>Prescribed Date</i>	<i>Suburb</i>	<i>Residential Equalisation Factor</i>	<i>Commercial Equalisation Factor</i>	<i>Industrial Equalisation Factor</i>
3053	1 January 1998	CARLTON	0.88	1.03	1.09
3054	"	CARLTON NORTH	0.88	1.03	1.09
3053	"	CARLTON SOUTH	0.88	1.03	1.09
3011	"	COODE ISLAND	N/A	N/A	1.13
3031	"	FLEMINGTON	0.83	1.02	1.13
3011	"	FOOTSCRAY	N/A	0.91	1.13
3002	"	JOLIMONT	0.91	1.33	1.33
3031	"	KENSINGTON	0.83	1.02	1.13

3000	”	MELBOURNE	1.03	1.89	1.31
3002	”	MELBOURNE EAST	0.91	1.33	1.33
3051	”	MELBOURNE NORTH	0.94	1.46	1.24
3205	”	MELBOURNE SOUTH	0.91	1.48	1.37
3003	”	MELBOURNE WEST	0.87	1.69	1.65
3052	”	PARKVILLE	0.98	1.03	1.03
3207	”	PORT MELBOURNE	0.84	1.33	1.45
3011	”	PORT OF MELBOURNE	N/A	0.91	1.13
3050	”	ROYAL MELBOURNE HOSPITAL	0.88	1.03	1.03
3005	”	WORLD TRADE CENTRE	N/A	1.15	N/A

Water Act 1989

GOULBURN-MURRAY RURAL WATER AUTHORITY

DIMINISHMENT OF EAST LODDON & WEST LODDON WATERWORKS DISTRICTS AND CAMPASPE & GOULBURN-MURRAY IRRIGATION DISTRICTS

Notice is hereby given that Goulburn-Murray Rural Water Authority intends to diminish the extent of its **East Loddon and West Loddon Waterworks Districts**, incorporating:

East Loddon Waterworks District:

Crown Allotment	Section	Parish
143, Pts 157, 163	—	Pompapriel

West Loddon Waterworks District:

Crown Allotment	Section	Parish
36, 39	3	Marmal
14	4	Marmal
110	—	Mysia
8	—	Terrappee

Notice is hereby given that Goulburn-Murray Rural Water Authority intends to diminish the extent of its **Campaspe Irrigation District** incorporating:

Crown Allotment	Section	Parish
Pt 89	—	Rochester West

Notice is hereby given that Goulburn-Murray Rural Water Authority intends to diminish the extent of its **Goulburn-Murray Irrigation District**, incorporating:

Cohuna Area:

Crown Allotment	Section	Parish
13, Pts 15, 17, 22, 23	7	Turrumberry North

Kerang Area:

Crown Allotment	Section	Parish
Pts 6A	3	Benjeroop

Murray Valley Area:

Crown Allotment	Section	Parish
Pts 17A, 18	C	Katunga

Rochester Area:

Crown Allotment	Section	Parish
13B	C	Colbinabbin
Pts 31, 32E, 32F	—	Echuca North
46A, 47A, Pt 48A	—	Wharparilla

Rodney Area:

Crown Allotment	Section	Parish
Pt 6A,	–	Mooroopna

Shepparton Area:

Crown Allotment	Section	Parish
Pt 74	–	Kialla
Pts 77, 78A, 79B	–	Shepparton
Pts 23, 24, 66, 75A, 75B, 102	C	Shepparton

Swan Hill Area:

Crown Allotment	Section	Parish
Pt 7	A	Castle Donnington

Tongala Area:

Crown Allotment	Section	Parish
Pts 105	D	Girgarre
Pt 73	C	Tongala

EXTENSION OF GOULBURN-MURRAY AND NYAH IRRIGATION DISTRICTS

Notice is hereby given that Goulburn-Murray Rural Water Authority intends to extend the boundary of its **Goulburn-Murray Irrigation District**, incorporating:

Boort Area:

Crown Allotment	Section	Parish
37B	–	Leaghur
36, 39	3	Marmal
14	4	Marmal
1, 3, 3A, 6, 7, 8, 9, 15B, Pts 5, 11	–	Meering West
110, 111, 176, 177, Pt 175	–	Mysia
8	–	Terrappee

Kerang Area:

Crown Allotment	Section	Parish
19B, 19C	3	Benjeroop

Murray Valley Area:

Crown Allotment	Section	Parish
72, 72A	–	Yielma

Pyramid Hill Area:

Crown Allotment	Section	Parish
73	–	Milloo
143, Pts 157, 163	–	Pompapriel

Rochester Area:

Crown Allotment	Section	Parish
10	A	Ballendella
33	C	Colbinabbin
131	–	Corop

Shepparton Area:

Crown Allotment	Section	Parish
Pt 126	–	Dargalong
Pts 18, 19, 20 Township of Katandra	–	Katandra

Woorinen Area:

Crown Allotment	Section	Parish
77	–	Woorinen

Notice is hereby given that Goulburn-Murray Rural Water Authority intends to extend the boundary of its **Nyah Irrigation District**, incorporating:

Crown Allotment	Section	Parish
2 Township of Nyah	9	Tyntynder North

The proposals have been advertised in accordance with the the **Water Act 1989**. Submissions will be received for one month after the publication of this notice.

Submissions should state grounds of objections to the proposals and will be considered at the Board of Authority's next meeting.

Copies of the Proposals may be inspected free of charge at the office of Goulburn-Murray Water, 40 Casey Street, Tatura during business hours.

DENIS FLETT
Chief Executive

Victoria Grants Commission Act 1976

NO. 8887

Supply of Information, 1997-98

Pursuant to Section 10 (1) (a) of the **Victoria Grants Commission Act 1976**, No. 8887, the Commission has fixed 26 October 1998 as the day by which each Municipal Council within the State of Victoria shall complete and return to the Commission the Return of Accounting and General Information and the date by which each Municipal Council shall provide the Commission with copies of the Statement of Accounts for the year ended 30 June 1998.

C. MORRISON
Executive Officer
Victoria Grants Commission

A copy of the Amendment can be inspected, free of charge, during office hours, at the Department of Infrastructure, Customer Service Centre, Upper Plaza, Nauru House, 80 Collins Street, Melbourne and at the offices of the Bayside City Council, Royal Avenue, Sandringham.

ADRIAN SALMON
Co-ordinator, Amendment Services
Local Government, Planning and
Market Information Services Division
Department of Infrastructure

Planning and Environment Act 1987

BAYSIDE PLANNING SCHEME

Notice of Approval of Amendment

Amendment L9

The Minister for Planning and Local Government has approved Amendment L9 to the Bayside Planning Scheme.

The Amendment comes into operation on the date this notice is published in the Government Gazette.

The Amendment rezones land at 7-13 Graham Road, Hihett from Light Industrial to Residential C and includes a site specific provision allowing the development of the land for 33 dwellings subject to the grant of a planning permit, but exempting any application from the advertising and appeal provisions of the **Planning and Environment Act 1987**.

Planning and Environment Act 1987

COLAC OTWAY PLANNING SCHEME

Notice of Approval of Amendment

Amendment L13

The Minister for Planning and Local Government has approved Amendment L13 to the Colac Otway Planning Scheme.

The Amendment comes into operation on the date this notice is published in the Government Gazette.

The Amendment introduces a site specific provision in the Rural 2 Zone enabling land described as Lot 1, Plan of Subdivision 327834A, Princes Highway, Colac West to be used and developed for the purposes of Motorcycle and All Terrain Vehicles sales, displays and repairs in accordance with a planning permit issued by the responsible authority and any conditions contained in an Agreement that may be entered into with the owner of the land pursuant to Section 173 of the **Planning and Environment Act 1987**.

A copy of the Amendment can be inspected, free of charge, during office hours, at the Department of Infrastructure, Customer Service Centre, Upper Plaza, Nauru House, 80 Collins Street, Melbourne and at the offices of the Colac Otway Shire Council, 2-6 Rae Street, Colac.

ADRIAN SALMON
Co-ordinator, Amendment Services
Local Government, Planning and
Market Information Services Division
Department of Infrastructure

Planning and Environment Act 1987
CRANBOURNE PLANNING SCHEME

Notice of Approval of Amendment
Amendment L226

The Minister for Planning and Local Government has approved Amendment L226 to the Cranbourne Planning Scheme.

The Amendment comes into operation on the date this notice is published in the Government Gazette.

The Amendment rezones land known as Crown Allotments 11D and 11E (176-178) Sladen Street, Cranbourne as shown on Plan of Crown Allotments CP118863 from Commercial Town Centre C Zone to Commercial Town Centre B Zone.

A copy of the Amendment can be inspected, free of charge, during office hours, at the Department of Infrastructure, Customer Service Centre, Upper Plaza, Nauru House, 80 Collins Street, Melbourne and at the offices of the Casey City Council, Princes Highway, Narre Warren.

ADRIAN SALMON
Co-ordinator, Amendment Services
Local Government, Planning and
Market Information Services Division
Department of Infrastructure

Planning and Environment Act 1987

HASTINGS PLANNING SCHEME
Notice of Approval of Amendment

Amendment L125

The Minister for Planning and Local Government has approved Amendment L125 to the Hastings Planning Scheme.

The Amendment comes into operation on the date this notice is published in the Government Gazette.

The Amendment introduces a site specific clause (Clause 142-4.9) within the Residential 3 Zone enabling an application for planning permit to be lodged with the responsible authority to subdivide Lot 3 on LP 201731 (2 The Ridge, Somerville) in accordance with Plan of Subdivision PS 415738F as prepared by P. G. Speedie and Associates dated 27 November 1997. The Amendment exempts an application for planning permit from the notice requirements of Section 52(1)(a), (b) and (d), the decision requirements of Section 64(1), (2) and (3) and the appeal rights of Section 82(1) of the **Planning and Environment Act 1987**.

A copy of the Amendment can be inspected, free of charge, during office hours, at the Department of Infrastructure, Customer Service Centre, Upper Plaza, Nauru House, 80 Collins Street, Melbourne and at the offices of the Mornington Peninsula Shire Council, Rosebud Office, Besgrove Street, Rosebud; Hastings Office, Marine Parade, Hastings; and Mornington Office, Queen Street, Mornington.

ADRIAN SALMON
Co-ordinator, Amendment Services
Local Government, Planning and
Market Information Services Division
Department of Infrastructure

Planning and Environment Act 1987

HEPBURN PLANNING SCHEME
Notice of Approval of Amendment

Amendment L4

The Minister for Planning and Local Government has approved Amendment L4 to the Hepburn Planning Scheme.

The Amendment comes into operation on the date this notice is published in the Government Gazette.

The Amendment rezones part of Crown Allotment 19, Section 28, Parish of Wombat (1.53 hectares) fronting the eastern side of Fourteenth Street, Hepburn Springs, from Rural Forest Zone to Residential Township Zone.

A copy of the Amendment can be inspected, free of charge, during office hours, at the Department of Infrastructure, Customer Service Centre, Upper Plaza, Nauru House, 80 Collins

Street, Melbourne, the Western Region Office, 1315 Sturt Street, Ballarat and at the offices of the Hepburn Shire Council, 76 Vincent Street, Daylesford.

ADRIAN SALMON
Co-ordinator, Amendment Services
Local Government, Planning and
Market Information Services Division
Department of Infrastructure

Planning and Environment Act 1987
HOBSONS BAY PLANNING SCHEME
Notice of Approval of Amendment
Amendment L6

The Minister for Planning and Local Government has approved Amendment L6 to the Hobsons Bay Planning Scheme.

The Amendment comes into operation on the date this notice is published in the Government Gazette.

The Amendment rezones Lot N Kororoit Creek Road, Williamstown from Proposed Public Open Space to the Williamstown Comprehensive Development Zone for the purposes of constructing a Motel/Convention Centre, Reception Rooms, Cabaret Restaurant and Bar.

A copy of the Amendment can be inspected, free of charge, during office hours, at the Department of Infrastructure, Customer Service Centre, Upper Plaza, Nauru House, 80 Collins Street, Melbourne and at the offices of the Hobsons Bay City Council, 115 Civic Parade, Altona.

ADRIAN SALMON
Co-ordinator, Amendment Services
Local Government, Planning and
Market Information Services Division
Department of Infrastructure

Planning and Environment Act 1987
KNOX PLANNING SCHEME
Notice of Approval of Amendment
Amendment L160

The Minister for Planning and Local Government has approved Amendment L160 to the Knox Planning Scheme.

The Amendment comes into operation on the date this notice is published in the Government Gazette.

The Amendment rezones land at the 889 and 891 Burwood Highway, Ferntree Gully from Knox Service Zone to a Business 4 Zone.

A copy of the Amendment can be inspected, free of charge, during office hours, at the Department of Infrastructure, Customer Service Centre, Upper Plaza, Nauru House, 80 Collins Street, Melbourne and at the offices of the Knox City Council, 511 Burwood Highway, Wantirna South.

ADRIAN SALMON
Co-ordinator, Amendment Services
Local Government, Planning and
Market Information Services Division
Department of Infrastructure

Planning and Environment Act 1987
MOIRA PLANNING SCHEME
Notice of Approval of Amendment
Amendment L20

The Minister for Planning and Local Government has approved Amendment L20 to the Moira Planning Scheme.

The Amendment comes into operation on the date this notice is published in the Government Gazette.

The Amendment inserts a new dot point in 'Clause 111-2.2 Smaller lots' of the Chapter 6 of the Moira Planning Scheme to allow for the subdivision of lot 2 PS 302840V into two lots.

A copy of the Amendment can be inspected, free of charge, during office hours, at the Department of Infrastructure, Customer Service Centre, Upper Plaza, Nauru House, 80 Collins Street, Melbourne, Department of Infrastructure, North Eastern Region, 50-52 Clarke Street, Benalla and at the offices of the Moira Shire Council, Melville Street, Numurkah.

ADRIAN SALMON
Co-ordinator, Amendment Services
Local Government, Planning and
Market Information Services Division
Department of Infrastructure

Planning and Environment Act 1987
MORELAND PLANNING SCHEME
Notice of Approval of Amendment
Amendment L57

The Minister for Planning and Local Government has approved Amendment L57 to the Moreland Planning Scheme.

The Amendment comes into operation on the date this notice is published in the Government Gazette.

The Amendment rezones land at 7-9 Cassells Road and 64-72 Tinning Street, Brunswick, from Light Industrial to a Mixed Use Zone. A Potentially Contaminated Overlay control will also apply to the land. The Amendment also makes an administrative correction to the Scheme.

A copy of the Amendment can be inspected, free of charge, during office hours, at the Department of Infrastructure, Customer Service Centre, Upper Plaza, Nauru House, 80 Collins Street, Melbourne and at the offices of the Moreland City Council, 90 Bell Street, Coburg.

ADRIAN SALMON
Co-ordinator, Amendment Services
Local Government, Planning and
Market Information Services Division
Department of Infrastructure

Planning and Environment Act 1987

NILLUMBİK PLANNING SCHEME

Notice of Approval of Amendment

Amendment L3

The Minister for Planning and Local Government has approved Amendment L3 to the Nillumbik Planning Scheme.

The Amendment comes into operation on the date this notice is published in the Government Gazette.

The Amendment makes a Bed and Breakfast establishment an as-of-right use in the:

- Diamond Valley Rural Residential Zone
- Diamond Valley Rural Residential R8 Zone
- General Farming A Zone
- Landscape Interest A Zone
- Landscape Interest C Zone
- Conservation A Zone
- Conservation Farming Zone
- Diamond Valley Conservation 2 Zone

provided certain requirements are met.

A copy of the Amendment can be inspected, free of charge, during office hours, at the Department of Infrastructure, Customer Service Centre, Upper Plaza, Nauru House, 80 Collins

Street, Melbourne and at the offices of the Nillumbik Shire Council, Civic Drive, Greensborough.

ADRIAN SALMON
Co-ordinator, Amendment Services
Local Government, Planning and
Market Information Services Division
Department of Infrastructure

Planning and Environment Act 1987

WERRIBEE PLANNING SCHEME

Notice of Approval of Amendment

Amendment L124

The Minister for Planning and Local Government has approved Amendment L124 to the Werribee Planning Scheme.

The Amendment comes into operation on the date this notice is published in the Government Gazette.

The Amendment rezones approximately 47 hectares of land north of Dunnings Road, Point Creek from Light Industrial to Residential 1 with a Development Plan Overlay.

A copy of the Amendment can be inspected, free of charge, during office hours, at the Department of Infrastructure, Customer Service Centre, Upper Plaza, Nauru House, 80 Collins Street, Melbourne and at the offices of the Wyndham City Council, 45 Princes Highway, Werribee.

ADRIAN SALMON
Co-ordinator, Amendment Services
Local Government, Planning and
Market Information Services Division
Department of Infrastructure

Planning and Environment Act 1987

CRANBOURNE PLANNING SCHEME

Notice of Lapsing of Amendment

Amendment L159

Pursuant to Section 30(1)(a) of the **Planning and Environment Act 1987**, Amendment L159 to the Cranbourne Planning Scheme has lapsed.

The Amendment proposed to insert a site specific control into the local section of the Berwick Planning Scheme to enable a permit to be granted for a shop with a floor area above the

160 metres squared maximum limit at Lots 33 and 34, LP 44583, (Nos 5-7) Camms Road, Cranbourne.

The Amendment lapsed on 1 February 1998.

ADRIAN SALMON
Co-ordinator, Amendment Services
Local Government, Planning and
Market Information Services Division
Department of Infrastructure

Planning and Environment Act 1987

MELBOURNE PLANNING SCHEME

Notice of Approval of Amendment

Amendment L303

The Minister for Planning and Local Government has approved Amendment L303 to the Melbourne Planning Scheme.

The Amendment comes into operation on the date this notice is published in the Government Gazette.

The Amendment changes the Melbourne Planning Scheme by inserting an incorporated document into Clause 313-5 of the Scheme which provides a site specific control for land at 224 Dudley Street allowing the addition of a third storey to an existing building and the development of 8,400 m² of office space to be used by Australia Post for a National Shared Services Facility and a National Data Centre.

A copy of the Amendment can be inspected, free of charge, during office hours, at the Department of Infrastructure, Customer Service Centre, Upper Plaza, Nauru House, 80 Collins Street, Melbourne, and at the offices of the Melbourne City Council, Development Planning, 7th Floor, 200 Little Collins Street, Melbourne 3000.

ADRIAN SALMON
Co-ordinator, Amendment Services
Local Government, Planning and
Market Information Services Division
Department of Infrastructure

ORDERS IN COUNCIL

Plant Health and Plant Products Act 1995

**DECLARATION OF AN AREA AT TOOLANGI TO BE A CONTROL AREA FOR THE
PURPOSE OF PREVENTING THE INTRODUCTION OF CERTAIN PESTS AND DISEASES**

The Governor in Council under section 9 of the **Plant Health and Plant Products Act 1995**-

- (a) declares the area described in Schedule 1 to be a control area for the purpose of preventing the introduction of western flower thrips and certain pests and diseases of potato, rubus and strawberry; and
- (b) specifies the prohibitions, restrictions and requirements in Schedule 2 as those which are to operate in the control area for the purpose of preventing the introduction of western flower thrips (*Frankiniella occidentalis*) and certain pests and diseases of potato, rubus and strawberry described in Schedule 3.

SCHEDULE 1

That portion of the Shire of Murrindindi bounded by a line commencing at the junction of the Melba Highway and Glenburn Road, then along the Melba Highway in a northerly direction to Victoria Range Track, then along Victoria Range Track in a south-easterly and easterly direction to Spraggs Road, then along Spraggs Road in a northerly direction to Nolans Road, then along Nolans Road in an easterly direction to Blowhard Road, then along Blowhard Road in a southerly direction and then in a north-easterly direction to Yea Link Track, then along Yea Link Track in a south-easterly direction to Sylvia Creek Road, then along an imaginary line in a south easterly direction to the summit of Mt. St. Leonard, then along the National Bicentennial Walking Trail in a southerly direction to National Grid Point 361837, then along an imaginary line due west to Lowes Track, then along Lowes Track in a northerly direction to Joshua Road, then along Joshua Road in a westerly direction to the Healesville Kinglake Road, then along the Healesville Kinglake Road in a southerly direction to Heath Road, then along Heath Road in a north westerly direction to Pauls Lane, then along Pauls Lane in a northerly direction to the Old Toolangi Dixons Creek Road, then along the Old Toolangi Dixons Creek Road in a northerly direction to Five Ways Track, then in along Five Ways Track in a general north-westerly direction to Glenwood Drive, then along Glenwood Drive in a westerly direction to the Melba Highway, then along the Healesville Road in a westerly and then a southerly direction to Glenburn Road, then in a north-easterly direction back to the junction of the Glenburn Road and the Melba Highway.

SCHEDULE 2

1. The introduction into the control area of any nursery plants, cut flowers or leafy vegetables is prohibited unless the nursery plants, cut flowers or leafy vegetables are -
 - (a) accompanied by a plant health certificate or a plant health declaration stating that the nursery plant, cut flower or leafy vegetable has been grown and packed on a property which has been inspected by a person authorised by the Secretary and no western flower thrips have been found; or
 - (b) treated in a manner to control western flower thrips approved by the Secretary; or
 - (c) in the case of leafy vegetables, they are for human consumption; or
 - (d) in the case of nursery plants or cut flowers, they are for domestic use.
2. The introduction into the control area of any potato tubers is prohibited unless the potato tubers are -
 - (a) accompanied by a plant health certificate or a plant health declaration stating that the potato tubers have been examined in a manner approved by the Secretary for the pests and diseases listed in Part 1 of Schedule 3 and no pests or diseases have been found; or
 - (b) certified in accordance with the provisions of a certification scheme approved by the Minister in accordance with section 40 of the Act; or
 - (c) only for human consumption.

3. The introduction into the control area of any rubus plants is prohibited unless the rubus plants are -
 - (a) accompanied by a plant health certificate or a plant health declaration stating that the plants have been examined in a manner approved by the Secretary for the diseases listed in Part 2 of Schedule 3 and no diseases are have been found; or
 - (b) certified in accordance with the provisions of a certification scheme approved by the Minister in accordance with section 40 of the Act.
4. The introduction into the control area of any strawberry plants is prohibited unless the strawberry plants are-
 - (a) accompanied by a plant health certificate or a plant health declaration stating that the plants have been examined in a manner approved by the Secretary for the diseases listed in Part 3 of Schedule 3 and no diseases have been found; or
 - (b) certified in accordance with the provisions of a certification scheme approved by the Minister in accordance with section 40 of the Act.
5. The introduction into the control area of any container or agricultural equipment which has been used for planting, cultivation or harvesting potatoes or other root vegetables is prohibited unless the container or equipment has been cleaned free of all plant material and soil and is accompanied by a plant health certificate or a plant health declaration.

SCHEDULE 3

Part 1

Pests and Diseases of Potato

Fungal Diseases

Colletotrichum coccodes

Fusarium species

Phoma exigua

Rhizoctonia solani

Spongospora subterranea

Phytophthora infestans

Phytophthora erythroseptica

Verticillium species

Bacterial Diseases

Erwinia species

Clavibacter michiganese pv sepodonicus

Pseudomonas solanacearum

Streptomyces scabies

Virus & Virus -Like Diseases

Potato leafroll virus

Potato virus A

Potato virus M

Potato virus S

Potato virus X

Potato virus Y

Potato spindle tuber viroid

Nematode Pests

Globodera rostochiensis

Globodera pallida

Part 2

Diseases of Rubus

Fungal Diseases

Armillaria species

Phytophthora fragariae var rubi

Phytophthora species

Verticillium dahliae

Vararia species

Virus Diseases

Apple mosaic virus

Cucumber mosaic virus

Raspberry bushy dwarf virus

Bacterial Diseases

Agrobacterium species

Part 3

Diseases of Strawberry

Fungal Diseases

Phytophthora fragariae var fragariae

Verticillium dahliae

Gnomonia comari

Bacterial Diseases

Xanthomonas fragariae

Dated: 25 August 1998.

Responsible Minister:

PATRICK McNAMARA

Minister for Agriculture and Resources

Virus & Virus -Like Diseases

Strawberry mild yellow edge virus

Strawberry crinkle virus

Strawberry vein-banding virus

Strawberry mottle virus

Strawberry green petal phytoplasma-like organism

Strawberry pallidosis syndrome

SHARNE BRYAN

Clerk of the Executive Council

Plant Health and Plant Products Act 1995

ORDER

Declaration of Plant Pests and Diseases

The Governor in Council under section 5 of the **Plant Health and Plant Products Act 1995** declares the following to be pests and diseases for the purposes of section 3 of that Act -

Pests

Siphoninus phillyreae

Diseases

Apple mosaic virus

Clavibacter michiganese pv sepedonicus

Raspberry bushy dwarf virus

Phytophthora fragariae var rubi

Phytophthora fragariae var fragariae

Strawberry green petal phytoplasma-like organism

Strawberry pallidosis syndrome

Vararia species

Xanthomonas fragariae

Dated: 25 August 1998.

Responsible Minister:

PATRICK McNAMARA

Minister for Agriculture and Resources

SHARNE BRYAN

Clerk of the Executive Council

Parliamentary Committees Act 1968

ORDER

Under the powers of section 4F(3) of the **Parliamentary Committees Act 1968**, the Governor in Council specifies that the time within which the Law Reform Committee is required to make a final report to Parliament on the review of the **Fences Act 1968** pursuant to the terms of reference dated 23 September 1997 is extended to 11 November 1998.

Dated 25 August 1998.

Responsible Minister:

JAN WADE

Attorney-General

SHARNE BRYAN

Clerk of the Executive Council

Health Services Act 1988

SECTION 8 HEALTH SERVICES ACT 1988

AMENDMENT TO SCHEDULE 4

New Latrobe Regional Hospital

The Governor in Council, acting on the recommendation of the Minister for Health, by this Order -

Amends, pursuant to section 8(3)(a) of the Act, Schedule 4 by:

adding the name "New Latrobe Regional Hospital".

This Order in Council is to take effect from 1 September 1998.

Dated: 25 August 1998.

Responsible Minister:
ROB KNOWLES
Minister for Health

SHARNE BRYAN
Clerk of the Executive Council

Land Act 1958

SALE OF CROWN LAND
BY PRIVATE TREATY

Order in Council

The Governor in Council, pursuant to section 99A(1)(a) & 99A(2) of the **Land Act 1958**, approves the sale by private treaty of Crown Allotments 2K and 2G Section 10X Parish of Melbourne South, County of Bourke, located in Fitzroy Street, St Kilda.

Dated 25 August 1998

Responsible Minister:
ROGER M. HALLAM MLC
Minister for Finance

SHARNE BRYAN
Clerk of the Executive Council

Land Act 1958

APPROVAL BY THE GOVERNOR IN
COUNCIL TO THE SALE OF

CROWN LAND BY PRIVATE TREATY
Order in Council

The Governor in Council, pursuant to section 99A(1)(a) & 99A(2) of the **Land Act 1958**, approves the sale by private treaty of the Crown land described below.

Property Address: Ellimatta Road, Anglesea.

Crown Description: Allotment 37, Section 2,
Township of Anglesea.

Dated 25 August 1998

Responsible Minister:
ROGER M. HALLAM MLC
Minister for Finance

SHARNE BRYAN
Clerk of the Executive Council

Land Act 1958

APPROVAL BY THE GOVERNOR IN
COUNCIL TO THE SALE OF
CROWN LAND BY PRIVATE TREATY
Order in Council

The Governor in Council, pursuant to section 99A(1)(a) & 99A(2) of the **Land Act 1958**, approves the sale by private treaty of the Crown land described below.

Property Address: Lancefield - Kyneton Road,
Cobar.

Crown Description: Allotment 1G6, Section A,
Parish of Cobar.

Dated 25 August 1998

Responsible Minister:
ROGER M. HALLAM MLC
Minister for Finance

SHARNE BRYAN
Clerk of the Executive Council

Crown Land (Reserves) Act 1978

NOTICE OF INTENTION

The Governor in Council under Section 10 of the **Crown Land (Reserves) Act 1978**, gives notice of intention to revoke the following temporary reservations to the extent indicated hereunder:

CRESWICK - The whole of the temporary reservation by Order in Council of 18 December, 1979 of an area of 3.076 hectares of land being Crown Allotments D1 and D2, Parish of Creswick as a site for a State School Forest Plantation. — (Rs 11107).

HAMILTON SOUTH - The whole of the temporary reservation by Order in Council of 18 January, 1977 of an area of 1.650 hectares of land being Crown Allotment 9C, Section 4, Parish of Hamilton South as a site for Public Purposes (Department of Agriculture purposes). — (Rs 9213).

HAMILTON SOUTH - The temporary reservation by Order in Council of 9 September, 1969 of an area of 5.605 hectares of land in Section 4, Parish of Hamilton South as a site for Public Purposes (Department of Agriculture purposes), revoked as to part by various Orders, so far as the balance remaining containing 5.447 hectares. — (Rs 9213).

MYRTLEFORD - The whole of the temporary reservation by Order in Council of 13 February, 1979 of an area of 9.559 hectares of land being Crown Allotment 3C, Section 9A, Parish of Myrtleford as a site for Water Supply purposes. — (Rs 10687).

WOMBAT - The temporary reservation by Order in Council of 12 January, 1892 of an area of 1.017 hectares of land in Section 27, Parish of Wombat as a site for Watering purposes, revoked as to part by Order in Council of 1 June, 1982 so far as the balance remaining containing 7400 square metres. — (Rs 12585).

This Order is effective from the date on which it is published in the Victoria Government Gazette.

Dated 25 August 1998

Responsible Minister:

MARIE TEHAN

Minister for Conservation and Land Management

SHARNE BRYAN
Clerk of the Executive Council

Crown Land (Reserves) Act 1978

NOTICE OF INTENTION

The Governor in Council under Section 10 of the **Crown Land (Reserves) Act 1978**, gives notice of intention to revoke the following temporary reservation:

TAWANGA - The temporary reservation by Order in Council of 11 April, 1972 of an area of 6045 square metres of land in Section 2, Parish of Tawanga as a site for State School purposes. — (Rs 4970).

This Order is effective from the date on which it is published in the Victoria Government Gazette.

Dated 25 August 1998

Responsible Minister:

MARIE TEHAN

Minister for Conservation and Land Management

SHARNE BRYAN
Clerk of the Executive Council

Crown Land (Reserves) Act 1978

REVOCATION OF TEMPORARY RESERVATIONS

The Governor in Council under Section 10 of the **Crown Land (Reserves) Act 1978**, revokes the following temporary reservations:

BENDIGO - The temporary reservation by Order in Council of 22 September, 1908 of an area of 7657 square metres of land in Section 16E, At Bendigo, Parish of Sandhurst (formerly part of Section 19A, City of Bendigo) as a site for the Storage of Water. — (06/17045).

CARPENDEIT - The temporary reservation by Order in Council of 19 November, 1974 of an area of 3 hectares, more or less, of land being Crown Allotment 55G, Parish of Carpendeit as a site for Public Purposes (Gravel Supply). — (Rs 10003).

CARPENDEIT - The temporary reservation by Order in Council of 19 November, 1974 of an area of 5.8 hectares, more or less, of land being Crown Allotment 55F, Parish of Carpendeit as a site for Public Purposes (Gravel Supply). — (Rs 10004).

CLUB TERRACE - The temporary reservation by Order in Council of 15 October, 1957 of an area of 1391 square metres of land in Section 9, Township of Club Terrace, Parish of Winyar as a site for the purposes of the Forests Acts. — (Rs 7624).

This Order is effective from the date on which it is published in the Victoria Government Gazette.

Dated 25 August 1998

Responsible Minister:

MARIE TEHAN

Minister for Conservation and Land Management

SHARNE BRYAN
Clerk of the Executive Council

Crown Land (Reserves) Act 1978

REVOCATION OF TEMPORARY RESERVATIONS

The Governor in Council under Section 10 of the **Crown Land (Reserves) Act 1978**, revokes the following temporary reservations to the extent indicated hereunder:

BENDIGO - The whole of the temporary reservation by Order in Council of 22 September, 1908 of an area of 6336 square metres of land in Section 16E, At Bendigo, Parish of Sandhurst (formerly Crown Allotment 28, Section 19A, City of Bendigo) as a site for the Storage of Water. — (06/17045).

CONEWARRE - The temporary reservation by Order in Council of 31 August, 1982 of an area of 3300 hectares, more or less, of land in the Parishes of Conewarre, Bellarine and Moolap as a site for the Management of Wildlife, revoked as to part by Orders in Council of 2 August, 1988 and 5 September, 1995, so far only as the portion containing 3.016 hectares shown as Crown Allotment L, Section 14, Parish of Conewarre on Certified Plan No. 118798 lodged in the Central Plan Office. — (Rs 12158).

YANGERY - The temporary reservation by Order in Council of 12 October, 1982 of an area of 610 hectares, more or less, of land being Crown Allotment D, Parish of Yangery as a site for the Management of Wildlife, so far only as the portion containing 1798 square metres shown as Crown Allotment 43A, Section A on Certified Plan No. 118613 lodged in the Central Plan Office. — (Rs 2687).

This Order is effective from the date on which it is published in the Victoria Government Gazette.

Dated 25 August 1998

Responsible Minister:

MARIE TEHAN

Minister for Conservation and Land Management

SHARNE BRYAN

Clerk of the Executive Council

Crown Land (Reserves) Act 1978

Interpretation of Legislation Act 1984

AMENDMENT OF TEMPORARY RESERVATION

The Governor in Council under Section 4 of the **Crown Land (Reserves) Act 1978**, and Section 27 of the **Interpretation of Legislation Act 1984** amends the Order in Council made on 30 April, 1957 and published in the Victoria Government Gazette on 8 May, 1957 of the temporary reservation of an area of 8094 square metres of land in the Township of Yarrowonga, Parish of Yarrowonga, County of Moira as a site for a Municipal depot by deletion of the words "Site for a Municipal depot" and the substitution therefor of the words "Public Park and Recreation". — Rs 7567.

This Order is effective from the date on which it is published in the Victoria Government Gazette.

Dated 25 August 1998

Responsible Minister:

MARIE TEHAN

Minister for Conservation and Land Management

SHARNE BRYAN

Clerk of the Executive Council

Crown Land (Reserves) Act 1978

CROWN LAND TEMPORARILY RESERVED

The Governor in Council under Section 4 of the **Crown Land (Reserves) Act 1978** temporarily reserves the following Crown lands for the purposes mentioned:-

MUNICIPAL DISTRICT OF THE GREATER BENDIGO CITY COUNCIL

BENDIGO - Care of Physically Disabled Persons, 1113 square metres, being Crown Allotment 316B, Section H, At Bendigo, Parish of Sandhurst as shown on Certified Plan No. 105552 lodged in the Central Plan Office. — (Rs 12945).

MUNICIPAL DISTRICT OF THE CORANGAMITE SHIRE COUNCIL

TERANG - Racecourse and Public Recreation, 1.67 hectares being Crown Allotment 9D, Section 18, Parish of Terang as indicated by hatching on plan hereunder. — (T86[3]) (Rs 2222).

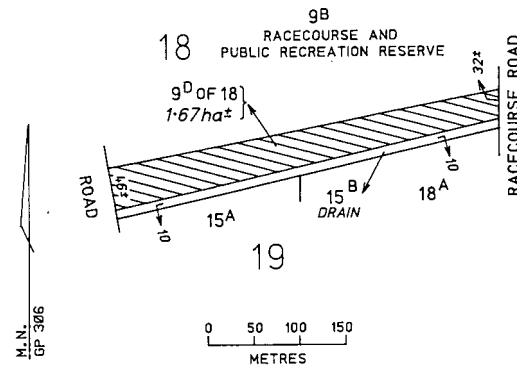

This Order is effective from the date on which it is published in the Victoria Government Gazette.

Dated 25 August 1998

Responsible Minister:

MARIE TEHAN

Minister for Conservation and Land Management

SHARNE BRYAN

Clerk of the Executive Council

Land Act 1958

UNUSED ROADS CLOSED

The Governor in Council under Section 349 of the **Land Act 1958** and with the consents in writing of the municipalities concerned and the adjoining owners closes the following unused roads:

MUNICIPAL DISTRICT OF THE SWAN HILL RURAL CITY COUNCIL

BUMBANG - The road in the Parish of Bumbang as indicated by hatching on plan hereunder. — (B660[9]) (01/420).

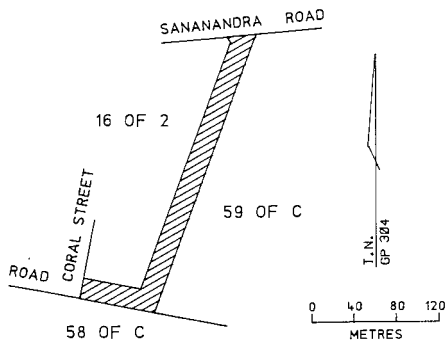

MUNICIPAL DISTRICT OF THE STRATHBOGIE SHIRE COUNCIL

TARCOMBE - The road in the Parish of Tarcombe as indicated by hatching on plan hereunder. (3547-1) (P182392).

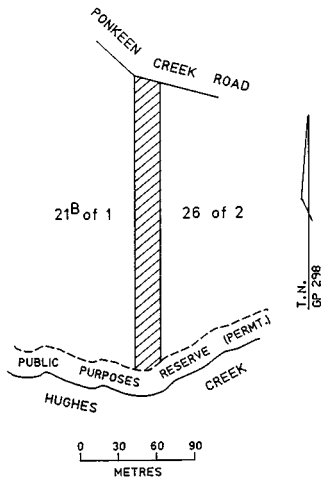

MUNICIPAL DISTRICT OF THE YARRIAMBIAK SHIRE COUNCIL

WIRRBIBIAL - The road in the Parish of Wirrbibial shown as Crown Allotment 13A on

Certified Plan No. 118811 lodged in the Central Plan Office. (2001959).

This Order is effective from the date on which it is published in the Victoria Government Gazette.

Dated 25 August 1998

Responsible Minister:
MARIE TEHAN

Minister for Conservation and Land Management

SHARNE BRYAN
Clerk of the Executive Council

VICTORIA

State Aid To Religion Abolition Act 1871

ACT NO. 391/1871 — SECOND SCHEDULE

A statement of trusts having been submitted by the head or authorised representative of the Uniting Church in Australia under the provisions of the "Act to provide for the abolition of State Aid to Religion" for allowance by the Governor in Council, the same was allowed by him on the Twenty-fifth day of August 1998, and the following is the form in which such statement of trusts has been allowed.

STATEMENT OF TRUSTS

DESCRIPTION OF LAND -

Site for the Wesleyan Church purposes temporarily reserved by Order in Council of 9 September, 1867, being 2023 square metres, Township of Cobden, Parish of Tandarook being Allotment 1, Section 21. Commencing at the south-eastern angle of allotment 3, section 21; bounded thence by that allotment bearing 0° 00' 50.29 metres; thence by a line bearing 90° 00' 40.23 metres; thence by Adams Street bearing 180° 00' 50.29 metres; and thence by Parrott Street bearing 270° 00' 40.23 metres to the point of commencement.

2023 square metres, Township of Cobden, Parish of Tandarook being Allotment 2, Section 21. Commencing at the north-eastern angle of allotment 3, section 21; bounded thence by Curdie Street bearing 90° 00' 40.23 metres; thence by Adams Street bearing 180° 00' 50.29 metres; thence by a line bearing 270° 00' 40.23 metres, and thence by allotment 3 bearing 0° 00' 50.29 metres to the point of commencement.

NAME OF TRUSTEES

The Uniting Church in Australia Property Trust (Victoria).

POWERS OF DISPOSITION

Such powers of disposition including powers of sale, lease or mortgage as are given to the Trustee by the **Uniting Church in Australia Act No. 9021 of 1977** as amended.

PURPOSES TOWARDS WHICH PROCEEDS OF DISPOSITION ARE TO BE APPLIED:-

To such Uniting Church in Australia purposes as shall be approved by the Synod of Victoria of the Uniting Church in Australia.

This Order is effective from the date on which it is published in the Victoria Government Gazette.

Dated 25 August 1998

Responsible Minister:

MARIE TEHAN

Minister for Conservation and Land Management

SHARNE BRYAN

Clerk of the Executive Council

LATE NOTICES

**Subordinate Legislation Act 1994
Firearms Act 1996**

NOTICE OF DECISION

**Proposed Firearms (Prescribed Circumstances)
Regulations 1998**

The proposed Firearms (Prescribed Circumstances) Regulations 1998 and Regulatory Impact Statement have been advertised for public comment and a number of submissions were received.

Following consideration of the submissions received, I now give notice of my intention to proceed with the making of the proposed Regulations, subject to some amendments.

BILL McGRATH
Minister for Police and Emergency Services

**SUBORDINATE LEGISLATION ACT 1994
NOTICE OF MAKING OF STATUTORY
RULES**

Notice is hereby given under Section 17 (2) of the **Subordinate Legislation Act 1994** of the making of the following Statutory Rules:

106. *Statutory Rule:* Magistrates' Court (Fees, Costs and Charges) (Amendment) Regulations 1998
Authorising Act: Magistrates' Court Act 1989
Date of making: 25 August 1998
107. *Statutory Rule:* Magistrates' Court General (Further Amendment) Regulations 1998
Authorising Act: Magistrates' Court Act 1989
Date of making: 25 August 1998
108. *Statutory Rule:* Gaming Machine Control (Fees) (Amendment) Regulations 1998
Authorising Act: Gaming Machine Control Act 1991
Date of making: 25 August 1998
109. *Statutory Rule:* Gaming Machine Control (Jackpots) (Amendment) Regulations 1998
Authorising Act: Gaming Machine Control Act 1991
Date of making: 25 August 1998

**SUBORDINATE LEGISLATION ACT 1994
NOTICE THAT STATUTORY RULES ARE
OBTAINABLE**

Notice is hereby given under Section 17 (3) of the **Subordinate Legislation Act 1994** that the following Statutory Rules were first obtainable from Information Victoria, 356 Collins Street, Melbourne on the date specified:

105. *Statutory Rule:* Control of Weapons (Amendment) Regulations 1998
Authorising Act: Control of Weapons Act 1990
Date first obtainable: 25 August 1998

Code A

Retail price will vary according to the number of pages in each special or periodical gazette. The table below sets out the prices that apply

<i>Price Code</i>	<i>No. of Pages (Including cover and blank pages)</i>	<i>Price</i>
A	1-16	\$2.90
B	17-32	\$4.30
C	33-48	\$5.90
D	49-96	\$9.15
E	97-144	\$11.85
F	145-192	\$14.00
G	193-240	\$16.15
H	241-288	\$17.20
I	289-352	\$19.35
J	353-416	\$22.60
K	417-480	\$25.80
L	481-544	\$30.10
M	545-608	\$34.40
N	609-672	\$38.70
O	673-736	\$43.00
P	737-800	\$47.30

ADVERTISERS PLEASE NOTE

As from 27 August 1998

The last Special Gazette was No. 85 dated 26 August 1998

The last Periodical Gazette was No. 1 dated 2 June 1998

CONTENTS

	Page
Estates of Deceased Persons	2283
Government and Outer Budget Sector	
Agencies Notices	2295
Orders in Council—	2320
Acts — Plant Health and Plant Products; Parliamentary Committees; Health Services; Land; Crown Land (Reserves); State Aid To Religion Abolition	
Private Advertisements	2283
Proclamations	2294

The Victoria Government Gazette is published by The Craftsman Press Pty. Ltd. with the authority of the Government Printer for the State of Victoria
© State of Victoria 1998

ISSN 0819-5471

This publication is copyright. No parts may be reproduced by any process except in accordance with the provisions of the Copyright Act.

Products and services advertised in this publication are not endorsed by The Craftsman Press Pty. Ltd. or the State of Victoria and neither of them accepts any responsibility for the content or the quality of reproduction. The Craftsman Press Pty. Ltd. reserves the right to reject any advertising material it considers unsuitable for government publication.

Address all inquiries to the Government Printer for the State of Victoria
1 Macarthur Street
Melbourne 3002 Victoria Australia

RETAIL SALES

Information Victoria Bookshop
356 Collins Street Melbourne 3000.
Telephone enquiries 1300 366 356

City Graphics
2nd Floor, 4 Bank Place
Melbourne 3000
Telephone enquiries (03) 9600 0977

Recommended Retail Price \$1.70

Government and Outer Budget Sector Agencies please note:
STYLE REQUIREMENTS.

To ensure that material received can be reproduced, and that errors are minimised, the following guidelines are to be observed when submitting material by fax.

Fax resolution:

Material sent by fax should be transmitted using Fine Resolution (200 dots per inch by 200 dpi).

Font size:

Use 12 point (10 pitch) or larger.

Font Style:

Clear plain font styles, such as Helvetica, should be used.

Graphics:

Line drawings should be transmitted as large as possible to ensure clarity. Drawings up to A4 size sent by fax using Fine Resolution provide a good quality for reproduction.

Avoid:

Italics, underlining and full justification.

Ensure document is square when sending as documents that are sent skewed are difficult to read and process.