



# Victoria Government Gazette

No. G 9 Thursday 4 March 1999

**GENERAL**

## GENERAL AND PERIODICAL GAZETTE

Copy to: Gazette Officer  
The Craftsman Press Pty. Ltd.  
125 Highbury Road,  
Burwood Vic 3125  
Telephone: (03) 9926 1233  
Facsimile: (03) 9926 1292  
DX: 32510 Burwood  
Email: [gazette@craftpress.com.au](mailto:gazette@craftpress.com.au)

### Advertising Rates and Payment

#### Private Notices

Payment must be received in advance with advertisement details.

30 cents per word - Full page \$180.00.

Additional costs must be included in prepayment if a copy of the gazette is required. Copy Prices - Page

\$1.50 - Gazette \$3.20 Certified copy of Gazette \$3.50. (all prices include Postage). **Cheques should be made payable to The Craftsman Press Pty. Ltd.**

#### Government and Outer Budget Sector Agencies Notices

Not required to pre-pay.

Advertisements may be faxed or sent via email with a cover sheet, marked to the attention of the Gazette Officer.

Floppy Disks (Mac & PC) can also be accepted.

Costs can be calculated on the following basis:

Per Line	Typeset
Single column	\$1.55
Double column	\$3.10
Full Page	\$64.80

The Craftsman Press is pleased to offer a series of discounts from the typesetting costs.

1. Copy supplied on disk.
2. Copy supplied via email.
3. Artwork for forms and other material which require exact reproduction.

#### 1. Copy supplied on disk.

Where a disk is supplied and there is minimum alteration required, **30% off.**

Where a disk is supplied requiring extraneous matter stripped out and styles applied, **20% off.**

#### 2. Copy supplied via email.

Where a notice is sent via email and there is minimum alteration required, **25% off.**

Where email is supplied requiring extraneous matter stripped out and styles applied, **15% off.**

#### 3. Artwork for forms and other material which requires exact reproduction.

Scanning and sizing of artwork for forms, to be reproduced in page format, **35% off.**

#### Copy Deadline for General Gazette

9.30 a.m. Monday - (Private Notices)

9.30 a.m. Tuesday - (Government and Outer Budget Sector Agencies Notices)

### Advertisers should note:

- Late copy received at The Craftsman Press Pty. Ltd. after deadlines will be placed in the following issue of VGG, irrespective of any date/s mentioned in the copy (unless otherwise advised).
- Proofs will be supplied only when requested or at the direction of the Gazette Officer.
- No additions or amendments to material for publications will be accepted by telephone.
- Orders in Council may be lodged prior to receiving assent with the Governor's or Clerk's signature. They will only be published once approved and signed.
- Government and Outer Budget Sector Agencies please note: *See style requirements on back page.*

## SPECIAL GAZETTES

Copy to: Gazette Officer  
The Craftsman Press Pty. Ltd.  
125 Highbury Road,  
Burwood Vic 3125  
Telephone: (03) 9926 1233  
Facsimile: (03) 9926 1292  
Email: [gazette@craftpress.com.au](mailto:gazette@craftpress.com.au)

### Advertising Rates and Payment

#### Private Notices

Full Page \$360.00

Payment must be received in advance with notice details.

#### Government and Outer Budget Sector Agencies Notices

	Typeset
Full Page	\$87.50

#### Note:

The after hours number for Special Gazettes is:  
Telephone: 0419 327 321

## SUBSCRIPTIONS AND RETAIL SALES

Copies of the Victoria Government Gazette can be purchased from The Craftsman Press Pty. Ltd. by subscription.

#### The Victoria Government Gazette

General and Special - \$170.00 each year

General, Special and Periodical - \$227.00 each year

Periodical - \$113.00 each year

Subscriptions are payable in advance and accepted for a period of one year. All subscriptions are on a firm basis and refunds will not be given.

**All payments should be made payable to The Craftsman Press Pty. Ltd.**

#### Subscription enquiries:

The Craftsman Press Pty. Ltd.  
125 Highbury Road, Burwood Vic 3125  
Telephone: (03) 9926 1233

## INDEX TO PRIVATE ADVERTISERS

<b>A</b>	<b>J</b>
Akehurst, Friend & Allaway ..... 529	John Keating & Associates ..... 531
Arthur J. Dines & Co ..... 529	John Stewart ..... 531
<b>B</b>	<b>M</b>
Biggs & Co ..... 529	McCluskys ..... 532
Bini & Associates ..... 530	Mal Ryan & Co ..... 532
Borchard & Moore ..... 530	Mason Sier Turnbull ..... 532
<b>C</b>	<b>N</b>
Chessell Williams ..... 530	National Mutual Trustees ..... 532
<b>E</b>	<b>P</b>
Eales & Mackenzies ..... 530	Price Higgins ..... 532
Equity Trustees Limited ..... 530	<b>R</b>
<b>G</b>	Read Kelly ..... 532
Garden & Green ..... 530	Robert King ..... 533
<b>H</b>	<b>S</b>
Home Wilkinson & Lowry ..... 531	Stuart Morgan & Associates ..... 533
H. S. W. Lawson & Co ..... 531	<b>T</b>
<b>I</b>	Tolhurst Druce & Emmerson ..... 533
IOOF Australia Trustees Limited ..... 531	<b>W</b>
	White Cleland Pty ..... 533
	Wisewoulds ..... 533

**PUBLICATION OF THE  
VICTORIA GOVERNMENT  
GAZETTE (GENERAL)  
LABOUR DAY - PUBLIC HOLIDAY**

**PLEASE NOTE:**

The Victoria Government Gazette for Labour Day week will be published on Thursday 11 March 1999. All copy for Private advertisements must reach the Government Gazette Office by no later than 9.30 a.m. on Friday, 5 March 1999. The deadline for advertisements for the Government and Outer Budget Sector Agencies remains unchanged, ie: Tuesday, 9 March 1999.

Where urgent gazettal is required after hours, arrangements should be made with Ann White on 0419 327 321.

**ANN WHITE**  
Government Gazette Officer

**PRIVATE ADVERTISEMENTS**

A One-day seminar

## Investigative Interviewing Techniques

An essential skill in the collection of evidence during the investigative process is the ability of the investigator to elicit information from a wide range of people from different cultural and socio-economic backgrounds. Eliciting this information is an inexact and often difficult process requiring certain skills, insights and an understanding of human nature.

Education Design Systems Pty Limited, a quality endorsed professional development and vocational education organisation is offering a one-day seminar which aims to:

- \* promote an appreciation of the relevance and importance of interviews in the investigative process;
- \* provide insights into the legal implications involved in investigative interviews; and
- \* provide insights into the knowledge and skills necessary to create an atmosphere in which the initial desire by the interviewee to remain silent is replaced by a willingness to confide in the interviewer.

**Date:** Friday 26 March 1999 - 9.00am to 4.30pm  
**Venue:** Lift 1, Level 2A, City Conference Centre  
 256 Flinders Lane, Melbourne  
**Cost:** \$295 (includes seminar handbook, morning and afternoon refreshments and Certificate of Attendance)

*For further information and registration contact: Seminar Secretariat, Conference Co-ordinators on Telephone: 02 6292 9000 - Facsimile: 02 6292 9002 - Email: conference@netinfo.com.au*



Quality System  
Quality Endorsed  
Company  
ISO 9001 Registered  
Standards Australia

### Education Design Systems Pty Limited

A national training organisation incorporated in 1990 and quality endorsed in accord with International Standard ISO9002



**EDS**

**Professional and Vocational Education Providers**

SCHEDULE 1 – ACT NO. 391

**Abolition of State Aid to Religion, 1871**

I, John Robertson Preston, head or authorized representative of the denomination known as The Uniting Church in Australia with the consent of The Uniting Church in Australia Property Trust (Victoria) trustees of the land described in the sub-joined statement of trustees and of Reverend Ray Foster being the person entitled to minister in or occupy a building or buildings upon the said land, hereby apply to the Governor of the State of Victoria for leave to dispose of the said land by the means and for the purposes mentioned in the said statement of trusts. And I hereby certify that the said land was temporarily reserved by Order in Council on the 21 February 1870 for the purpose of a site for Presbyterian Church purposes. That the only trustees of the said land resident in the State of Victoria are The Uniting Church in Australia Property Trust (Victoria) of 130 Little Collins

Street, Melbourne. That the only buildings upon the said land are Church buildings. That the only person entitled to minister in or occupy the same is the abovenamed Reverend Ray Foster.

J. R. PRESTON

THE COMMON SEAL OF THE )  
 UNITING CHURCH IN AUSTRALIA )  
 PROPERTY TRUST (VICTORIA) )  
 was hereto affixed in pursuance of a )  
 resolution passed at a meeting of the )  
 Members of the Trust in the presence of: )

MARGARET WATSON

Member of Trust

J. R. PRESTON

Member of Trust

RAY FOSTER

STATEMENT OF TRUSTS

*Description of land:* 4056 square metres, Township of Amphitheatre, Parish of Glenlogie, being Crown Allotment 2A, section 3A.

Commencing at the most southern angle of allotment 2, section 3A: bounded thence by a road 233°00' 52.10 metres and bearing 323°00' 77.85 metres; thence by a line bearing 53°00' 52.10 metres, and thence by allotment 2 bearing 143°00' 77.85 metres to the point of commencement.

**Names of Trustees:** The Uniting Church in Australia Property Trust (Victoria).

**Powers of Disposition:** Such powers of disposition including powers of sale, lease or mortgage as are given to the Trustee by the Uniting Church in Australia Act No. 9021 of 1977 as amended.

**Purposes to which proceeds of Disposition are to be applied:** To such Uniting Church in Australia purposes as shall be approved by the Synod of Victoria of the Uniting Church in Australia.

Creditors, next-of-kin and others having claims in respect of the estate of JUNE ETHEL STEPHENSON, late of 28 Erowal Street, Beaumaris, deceased, who died on 12 October 1998 are required by Gregory William Stephenson and John Stuart Stephenson of 28 Erowal Street, Beaumaris, to send particulars of their claim to the said Greg William Stephenson and John Stuart Stephenson by 4 May 1999 after which date they will convey or distribute the assets having had regard only to the claims of which they then have notice.

AKEHURST, FRIEND AND ALLAWAY,  
Legal Practitioner,  
Suite 1102, 10 Queen Street, Melbourne 3000.

MURIEL GRACE BJORKSTEN (formerly Muriel Grace Rice), late of 16 Clarke Street, Thomastown, in the State of Victoria, pensioner, deceased. Creditors, next-of-kin and others having claims in respect of the estate of the deceased, who died on 24 July 1997, are required by the executor, Tevlyn Norman Haack, care of Arthur J. Dines & Co., solicitors, 2A Highlands Road, Thomastown, in the said State, to send particulars to him by 24 April 1999 after which date the executor may convey or distribute the assets having regard only to claims to which he has notice.

ARTHUR J. DINES & CO., solicitors,  
2A Highlands Road, Thomastown 3074.

VANGIL BOGLIS, also known as Bill Boglis, late of 12B Elliot Street, Reservoir, in the State of Victoria, semi retired, deceased.

Creditors, next-of-kin and others having claims in respect of the estate of the deceased, who died on 9 August 1997, are required by the executrix, Eleni Boglis, care of Arthur J. Dines & Co., solicitors, 2A Highlands Road, Thomastown, in the said State, to send particulars to her by 24 April 1999 after which date the executrix may convey or distribute the assets having regard only to claims to which she has notice.

ARTHUR J. DINES & CO., solicitors,  
2A Highlands Road, Thomastown 3074.

STEFANOS SHOMOS, late of 114 Warralong Avenue, Greensborough, in the State of Victoria, pensioner, deceased. Creditors, next-of-kin and others having claims in respect of the estate of the deceased, who died on 6 February 1998, are required by the executors, Paul Shomos and Tom Shomos, care of Arthur J. Dines & Co., solicitors, 2A Highlands Road, Thomastown, in the said State, to send particulars to them by 24 April 1999 after which date the executors may convey or distribute the assets having regard only to claims to which they have notice.

ARTHUR J. DINES & CO., solicitors,  
2A Highlands Road, Thomastown 3074.

BRIAN MURRAY STEELE, late of 7 Stewart Street, Thomastown, in the State of Victoria, storeman, deceased. Creditors, next-of-kin and others having claims in respect of the estate of the deceased, who died on 6 October 1998, are required by the executrix, Dora May Steele, care of Arthur J. Dines & Co., solicitors, 2A Highlands Road, Thomastown, in the said State, to send particulars to her by 24 April 1999 after which date the executrix may convey or distribute the assets having regard only to claims to which she has notice.

ARTHUR J. DINES & CO., solicitors,  
2A Highlands Road, Thomastown 3074.

Creditors, next-of-kin and all persons having claims against the estate of ATHOL JOESPH ANDERSON, late of 46A Molyneux Street, Warracknabeal, Victoria, gentleman, deceased, who died on 25 September 1998 are required to send particulars to the executor, Equity Trustees Limited, A.C.N. 004 031 298 of 472 Bourke Street, Melbourne, Victoria, on or before 14 May 1999 after which date it will distribute the assets having regard only to the claims of which it shall then have notice.

BIGGS & CO., solicitors,  
2273 Point Nepean Road, Rye 3941.

Creditors, next-of-kin and others having claims in respect of the estate of ANTONIO TARDIO, late of Walsh Road, Thorpdale, Victoria, farmer, deceased, who died on 10 June 1996, are requested to send particulars of their claims to the administrator care of the undermentioned solicitors by 10 May 1999 after which date he will convey or distribute the assets having regard only to the claims of which he then has notice.

BINI & ASSOCIATES, solicitors,  
1st Floor, 333 Drummond Street, Carlton 3053.

---

Creditors, next-of-kin and others having claims in respect of the estate of MARJORIE WINIFRED SPIVEY, late of 24 Ellendale Road, Noble Park, Victoria, home duties, deceased, who died on 25 November 1998 are required to send particulars of their claims to the executors care of the undermentioned solicitors by 4 May 1999 after which date the executors will distribute the assets having regard only to the claims for which notice has been received.

BORCHARD & MOORE, solicitors,  
44 Douglas Street, Noble Park.

---

Creditors, next-of-kin and others having claims in respect of the estate of MAY FARRANCE, late of 124 Harcourt Street, Hawthorn East, Victoria, married woman, who died on 7 October 1998 are requested to send particulars of their claim to the executor care of the undermentioned solicitors by 10 May 1999 after which date the executor will distribute the assets having regard only to the claims of which the executor then has notice.

CHESSELL WILLIAMS, solicitors,  
379 Collins Street, Melbourne 3000.

---

CAROLINE MACUMBER, late of 15 Carcoola Road, Ringwood East, Victoria, home duties, deceased. Creditors, next-of-kin and others having claims in respect of the estate of the deceased, who died on 7 January 1999 are required by the trustees, William Edward George Macumber of 5 Wirunga Street, East Ringwood, Victoria, retired gentleman, Caroline Joan McKay of 10 Wilsons Lane, Lilydale, Victoria, gentlewoman and Doreen Susan Jones of 45 Long Drive, Sunbury, Victoria, gentlewoman, to send particulars to the trustees by 27 April 1999 after which date the trustees

may convey or distribute the assets having regard only to the claims of which the trustees then have notice.

EALES & MACKENZIE, solicitors,  
114-116 Main Street, Lilydale.

---

PATRICIA ELIZABETH PRITCHARD, late of 8 Shafer Court, Endeavour Hills, Victoria, deceased. Creditors, next-of-kin and others having claims in respect of the estate of the deceased, who died on 24 September 1998 are required by the trustees, LESLIE FRANCIS PRITCHARD of 32 Bayview Avenue, Tenby Point, Victoria, student and Christopher Robert Pritchard of 6-8 Woodsmoke Court, Morayfield, Queensland, manager, to send particulars to the trustees by 27 April 1999 after which date the trustees may convey or distribute the assets having regard only to the claims of which the trustees then have notice.

EALES & MACKENZIE, solicitors,  
114-116 Main Street, Lilydale.

---

Creditors, next-of-kin and others having claims in respect of the estate of DUNCAN LINDSAY COLLIE, late of 8/25 Rockley Road, South Yarra, deceased, who died on 29 November 1998, are to send particulars of their claims to Equity Trustees Limited of 472 Bourke Street, Melbourne, by 29 April 1999 after which date it will distribute the assets having regard only to the claims of which it then has notice.

DOROTHY LILLIAN EDITH MAY CARTER, late of 6 Ford Street, Swan Hill, Victoria, widow, deceased. Creditors, next-of-kin and others having claims in respect of the estate of the deceased, who died on 4 December 1998 are required by the trustee, Geoffrey Raymond Moore, to send particulars to him care of the undermentioned solicitors by 26 April 1999 after which date the trustee may convey or distribute the assets having regard only to the claims of which he then has notice.

GARDEN & GREEN, lawyers,  
4 McCallum Street, Swan Hill.

---

GRAHAM HEBDEN EPPS, late of 5 Lloyd Street, Kerang, Victoria, retired mechanic, deceased. Creditors, next-of-kin and others having claims in respect of the estate of

the deceased, who died on 25 November 1998 are required by the trustees, Harry Alexander Kerr and George Frederick Bassler, to send particulars to them care of the undermentioned solicitors by 19 April 1999 after which date the trustees may convey or distribute the assets having regard only to the claims of which they then have notice.

GARDEN & GREEN, lawyers,  
4 McCallum Street, Swan Hill.

---

Creditors, next-of-kin and others having claims in respect of the estate of JOYCE LORRAINE HULL, late of 28 Niemur Street, Barham, in the State of New South Wales, who died on 4 October 1998, are required by the personal representatives of the deceased, Roger Michael Stansfield and Glenn Robert Hodges, solicitors, to send particulars to them c/- of the undermentioned solicitors by 28 April 1999 after which date they will distribute the assets having regard only to the claims of which they then have notice.

HOME WILKINSON & LOWRY, solicitors,  
Level 44, Nauru Nouse,  
80 Collins Street, Melbourne 3000.

---

BESSIE WILHELMENA VICTORIA WARREN, deceased. Creditors, next-of-kin and others having claims in respect of the estate of the deceased, who died on 5 May 1998 at Castlemaine, in the State of Victoria, are required by the trustee, Judith-Ann Gillard of 97 South Road, Brighton, to send particulars to her by 1 May 1999 after which date the trustee may convey or distribute the assets having regard only to the claims of which she then has notice.

H. S. W. LAWSON & CO., solicitors,  
157 Barker Street, Castlemaine.

---

Creditors, next-of-kin or beneficiaries having claims in respect of the estate of JAMES PATRICK GEORGE MULLINS, late of 14 Libra Street, North Balwyn, Victoria, Metal Moulder, deceased, who died on 8 March 1998 are to send particulars of their claim to the undersigned by 4 May 1999 after which date we will distribute the assets having regard only to the claims of which we then have notice.

IOOF AUSTRALIA TRUSTEES LIMITED,  
212 Pirie Street, Adelaide, SA 5000.

---

Creditors, next-of-kin or beneficiaries having claims in respect of the estate of CLARICE CAROLINE THOMAS, late of

Catholic Homes for the Elderly, 1 Clayton Road, North Balwyn, Victoria, home duties, deceased, who died on 10 September 1998 are to send particulars of their claim to the undersigned by 4 May 1999 after which date we will distribute the assets having regard only to the claims of which we then have notice.

IOOF AUSTRALIA TRUSTEES LIMITED,  
212 Pirie Street, Adelaide, SA 5000.

---

Creditors, next-of-kin or beneficiaries having claims in respect of the estate of STANLEY HUGHES THRELFALL, late of 29 Bruce Street, Bulleen, Victoria, retired chemical engineer, deceased, who died on 28 September 1998 are to send particulars of their claim to the undersigned by 4 May 1999 after which date we will distribute the assets having regard only to the claims of which we then have notice.

IOOF AUSTRALIA TRUSTEES LIMITED,  
212 Pirie Street, Adelaide, SA 5000.

---

Creditors, next-of-kin or others having claims in respect of the estate of ELMAR JAKOBSON, late of 25 Airlie Avenue, East Prahran, Victoria, designer, deceased, who died on 3 November 1998 are to send particulars of their claims to the executor, care of the undermentioned solicitors by 4 May 1999 after which date the executor will distribute the assets having regard only to the claims of which the executor then has notice.

JOHN KEATING & ASSOCIATES, solicitors,  
191 Greville Street, Prahran 3181.

---

Creditors, next-of-kin and others having claims in respect of the will of IRENE MAY COX, also known as Eileen Cox, late of Flat 11, 61 Churchill Avenue, Ascot Vale, Victoria, widow, deceased, who died on 21 January 1999, are requested to send particulars of their claims to the executors, John Stewart and Clifford Henry Cox, care of the undermentioned legal practitioner, by 5 May 1999 after which date they will distribute the assets having regard only to the claims of which they then have notice.

JOHN STEWART, legal practitioner,  
290 Racecourse Road, Newmarket.

---

Creditors, next-of-kin and others having claims in respect of the will and codicils of MARY ANNE WALSH, late of 2 Malmsbury Street, Kew, Victoria, widow, deceased, who died on 12 January 1999 are requested to send particulars of their claims to the executors,

Margaret Mary Curmi and Anthony John Moran, care of the undermentioned legal practitioner, by 5 May 1999 after which date they will distribute the assets having regard only to the claims of which they then have notice.

JOHN STEWART, legal practitioner,  
290 Racecourse Road, Newmarket.

---

IRIS MARY ARKELL, late of 51 Lyons Street, Port Melbourne, Victoria, home duties, deceased. Creditors, next-of-kin and others having claims in respect of the estate of the deceased, who died on 27 December 1998 are required by the executor, Julie Annette Miles, to send particulars of their claim to the executor care of the undermentioned solicitors by 5 May 1999 after which date the executor intends to convey or distribute the assets of the estate having regard only to the claims of which the executor may have notice.

McCLUSKYS, solicitors,  
254 Bay Street, Port Melbourne, Vic.3207.

---

ALICE MARY KERR, late of Mt. Buller Road, Mansfield, Victoria, widow, deceased. Creditors, next-of-kin and others having claims in respect of the estate of the deceased, who died on 2 September 1998 are required by her trustees, Terence Hurley Kerr of 13 Finchley Avenue, Glenroy, Victoria, supervising arborist and John Francis Bourke of 75 Monds Avenue, Benalla, Victoria, stock and station agent, to send particulars to them care of the undermentioned firm of legal practitioners by 3 May 1999 after which date the trustees may convey or distribute the assets having regard only to the claims of which they then have notice.

MAL RYAN & GLEN,  
legal practitioners for the trustees,  
9 High Street, Mansfield 3722.

---

Creditors, next-of-kin and others having claims in respect of the estate of REGINALD WILLIAM NEAL, late of 12 Lewton Road, Mount Waverley, Victoria, retired, deceased, who died on 14 November 1998 are required to send particulars of their claims to the executors, care of the undermentioned solicitors by 4 May 1999 after which date the executors will distribute the assets having regard only to the claims of which they then have notice.

MASON SIER TURNBULL, solicitors,  
5 Hamilton Place, Mount Waverley.

---

LESLEY BONNA MACAFEE, formerly of 34 Sylvander Street, North Balwyn, but late of Bodalla Nursing Home, 32 Walpole Street, Kew, widow. Creditors, next-of-kin and others having claims in respect of the estate of the deceased, who died on 12 December 1998 are required by National Mutual Trustees Limited and Gaynor Margaret Clifford, care of 65 Southbank Boulevard, Southbank, Victoria 3006, the applicants for a grant of probate, to send particulars to it by 6 May 1999 after which date the applicants for a grant of probate may convey or distribute the assets having regard only to the claims of which they then have notice.

---

Creditors, next-of-kin and others having claims in respect of the estate of ANNIE NISBET, late of 41 Godfrey Street, Wedderburn, Victoria, home duties, deceased, who died on 20 December 1998, are required to send particulars of their claims to the executors, National Mutual Trustees Limited of 46 Queen Street, Bendigo, by 12 May 1999 after which date they will distribute the assets having regard only to the claims of which they then have notice.

NATIONAL MUTUAL TRUSTEES LIMITED,  
46 Queen Street, Bendigo.

---

STANLEY WILLIAM STOATE, late of 24 Burns Street, Bannockburn, Victoria, retired, deceased. Creditors, next-of-kin and others having claims in respect of the estate of the deceased, who died on 29 May 1998 are required by Robert John Thomson of 15 Helms Street, Newcomb, Victoria, woolbuyer, the applicant for a grant of probate of the will dated 28 May 1998 of the deceased, to send particulars to him care of the undermentioned solicitors by 6 May 1999 after which date the said applicant may convey and distribute the assets having regard only to the claims of which he then has notice.

PRICE HIGGINS, solicitors,  
47 Yarra Street, Geelong.

---

BRIAN WILLIAM POWELL, late of 15 Vista Avenue, East Ringwood, Victoria, but formerly of 10 Lyminge Street, Croydon Park, NSW, clerk, deceased. Creditors, next-of-kin and others having claims in respect of the estate of the deceased, who died on 28 November 1998 are required by the trustee, Patricia May Powell of 15 Vista Avenue, East Ringwood, Victoria, home duties, to send particulars to the trustee by 6 May 1999 after which date the



trustee may convey or distribute the assets having regard only to the claims of which the trustee then has notice.

READ KELLY, solicitors,  
7th Floor, 555 Lonsdale Street, Melbourne.

---

MARIE FLORENCE SOANES, late of C/o Leighton Nursing Home, 1 Templestowe Road, Bulleen, Victoria, but, formerly of 1 Fyfe Drive, Lower Templestowe, Victoria, home duties, deceased. Creditors, next-of-kin and others having claims in respect of the estate of the deceased, who died on 18 September 1998 are required by the trustees, Janine Patricia Tollitt (formerly Soanes) of 20 Oak Crescent, Lower Templestowe, Victoria, company director and Ann-Maree (in the will spelt Ann-Marie) Robertson (formerly Soanes) of 214 Canterbury Road, Heathmont, Victoria, accountant, to send particulars to the trustees by 6 May 1999 after which date the trustees may convey or distribute the assets having regard only to the claims of which the trustees then have notice.

READ KELLY, solicitors,  
7th Floor, 555 Lonsdale Street, Melbourne.

---

Creditors, next-of-kin and others having claims in respect of the estate of VALERIE MAY STILES, late of 7 Hume Street, Armadale, Victoria, who died on 10 June 1998 are required by her trustees to send particulars of their claim to the undermentioned solicitor by 26 May 1999 after which date the trustees will convey or distribute the assets having regard only to the claims of which the trustees then have notice.

ROBERT KING, solicitor,  
97 Kooyong Road, Armadale 3143.

---

Creditors, next-of-kin and others having claims in respect of the estate of GRACE ESTHER NEWTON, late of 248 Tooronga Road, Glen Iris, in the State of Victoria, deceased, who died on 22 December 1998 are required by the executors and trustees, to send particulars to them care of the undermentioned solicitors by 4 May 1999 after which date the executors and trustees may convey or distribute the assets having regard only to the claims of which they then have notice.

STUART MORGAN & ASSOCIATES,  
solicitors,  
238 Glenferrie Road, Malvern 3144.

---

Creditors, next-of-kin and others having against the estate of JOHN WILLIAM BARRY RICHARDS, late of 5 Best Street, Sea Lake, Victoria, pharmacist, deceased, who died on 2 December 1998 are required to send particulars of their claims to Rosalie Richards of 4 Best Street, Sea Lake, Victoria, widow, the administrator of the said deceased, on or before 4 May 1999 after which date she will distribute the assets having regard only to the claims of which she then has notice.

TOLHURST DRUCE & EMMERSON,  
solicitors,  
389 Lonsdale Street, Melbourne.

---

HERBERT CECIL WALLACE, late of 25 Bilbul Avenue, Rosebud, Victoria, deceased. Creditors, next-of-kin and others having claims in respect of the estate of the deceased, who went missing, presumed dead in or about August 1993, are required by the administrator, Millicent Wallace, C/- White Cleland, solicitors, Post Office Box 318, Frankston 3199, to send particulars to her by 4 May 1999 after which date she may convey or distribute the assets having regard only to the claims of which she then has notice.

WHITE CLELAND PTY, solicitors,  
Landmark Building,  
454 Nepean Highway, Frankston.

---

DORIS BLANCHE RICHARDSON, late of 33 Fakenham Road, Ashburton, Victoria, widow, deceased. Creditors, next-of-kin and others having claims in respect of the estate of the deceased, who died on 22 November 1998 are required by the executors, John Beresford Damman and Lynette Faye Damman, to send particulars to the executors by 4 May 1999 after which date the executors intend to convey or distribute the assets of the estate having regard only to the claims of which the executors may have notice.

WISEWOULDS, solicitors,  
459 Collins Street, Melbourne.

---

In the Supreme Court of the State of Victoria  
SALE BY THE SHERIFF

On 8 April 1999 at 2.30 p.m. at the Sheriff's Office, 8-20 King Street, Oakleigh, (unless process be stayed or satisfied).

All the estate and interest (if any) of Philip Turner and Beverley Turner of 2 Lawn Court,

Frankston, as shown on Certificate of Title as Philip John Turner and Beverley Jean Turner, joint proprietors of an estate in fee simple in the land described on Certificate of Title Volume 8686 Folio 896 upon which is erected a home known as 2 Lawn Court, Frankston.

Registered Mortgage No. G533351 affects the said estate and interest.

Terms - Cash only.

SW-98-014830-1

Dated 4 March 1999.

S. BLOXIDGE  
Sheriff's Office

In the County Court of the State of Victoria  
SALE BY THE SHERIFF

On 8 April 1999 at 2.30 p.m. at the Sheriff's Office, 8-20 King Street, Oakleigh, (unless process be stayed or satisfied).

All the estate and interest (if any) of Ivan Kanja of 4 Sherwood Crescent, Dandenong, proprietor of an estate in fee simple in the land described on Certificate of Title Volume 9854 Folio 980 which is a vacant block of land known as 9 Armiston Court, Endeavour Hills.

Registered Mortgage No. P363101S and the Covenant in instrument No. P363100V affect the said estate and interest.

Terms - Cash only.

CW-98-011829-2

Dated 4 March 1999.

S. BLOXIDGE  
Sheriff's Office

In the Supreme Court of the State of Victoria  
SALE BY THE SHERIFF

On 8 April 1999 at 2.30 p.m. at the Sheriff's Office, 8-20 King Street, Oakleigh, (unless process be stayed or satisfied).

All the estate and interest (if any) of Laurie Allan Joseph Mackey of 21 Curzon Street, West Melbourne, joint proprietor with Lynette Vida Hayley of an estate in fee simple in the land described on Certificate of Title Volume 10136 Folio 840 upon which is erected a dwelling known as 21 Curzon Street, West Melbourne.

Registered Mortgage No. S821800D affects the said estate and interest.

Terms - Cash only.

SW-98-013725-1.

Dated 4 March 1999.

S. BLOXIDGE  
Sheriff's Office

**Unclaimed Moneys Act 1962**

Register of Unclaimed Moneys held by the —

<i>Name of Owner on Books and Last Known Address</i>	<i>Total Amount Due to Owner</i>	<i>Description Of Unclaimed Money</i>	<i>Date when Amount first became Payable</i>
ARBEE REAL ESTATE			
	\$		
S. Cullen, 13 Neerim Street, Melton South	150.00	Security Bond	04/04/90

99001

CONTACT: VIVYENNE REGO, PHONE: (03) 5367 2333.

**Unclaimed Moneys Act 1962**

Register of Unclaimed Moneys held by the —

<i>Name of Owner on Books and Last Known Address</i>	<i>Total Amount Due to Owner</i>	<i>Description Of Unclaimed Money</i>	<i>Date when Amount first became Payable</i>
MORNINGTON PENINSULA SHIRE COUNCIL			
	\$		
N. I. Lood	200.00	Receipt	19/10/93
Obetz Holding	200.00	"	28/04/94
Elizabeth Cross, 151 Finch Iris, Glen Iris	170.00	Cheque	06/03/96
Arbocultural Association, P.O. Box 319, Noble Park	120.00	"	19/03/96
Arbocultural Association, P.O. Box 319, Noble Park	120.00	"	10/04/96
South Australian Asset	990.00	Receipt	07/11/94
Nova Library Supplies, 35 Gilbert Drive, Scoresby	348.00	Cheque	26/06/97
Hastings Yacht Club, P.O. Box 46, Hastings	320.00	"	09/01/96
Lindsay Sinclair	1,000.00	Receipt	1994
Wech	100.00	"	14/12/89
Melham	200.00	"	14/02/90
Watsons	100.00	"	15/12/89
P. Arnold	130.00	"	23/03/95
Andrew Pope	200.00	"	16/05/94
J. Galtieri	200.00	"	28/01/91
McDonald Construction	200.00	"	05.04.91
Johnston	200.00	"	27/03/91
Hoban Hynes, 3/364 Main Street, Mornington	200.00	"	02/07/90
Chadwick	100.00	"	28/11/89
J. Sanderson	200.00	Cheque	10/03/92
Mrs F. Sharp	102.30	"	26/02/97

99003

CONTACT: SHARON BRYANT PHONE: (03) 5986 0106.

**PROCLAMATIONS**

**Transport Acts (Amendment) Act 1998**  
**PROCLAMATION OF COMMENCEMENT**

I, James Gobbo, Governor of Victoria, with the advice of the Executive Council and under section 2(3) of the **Transport Acts (Amendment) Act 1998**, fix 4 March 1999 as the day on which the remaining provisions of that Act come into operation.

Given under my hand and the seal of Victoria on 2 March 1999.

(L.S.) JAMES GOBBO  
Governor  
By His Excellency's Command

ROBIN COOPER  
Minister for Transport

This Proclamation is effective from the date on which it is published in the Victoria Government Gazette.

Given under my hand and the seal of Victoria on 2 March 1992.

(L.S.) JAMES GOBBO  
Governor  
By His Excellency's Command

MARIE TEHAN  
Minister for Conservation and Land Management

**Land Act 1958**  
**PROCLAMATION OF ROAD**

I, James Gobbo, Governor of Victoria acting with the advice of the Executive Council and under section 25(3)(c) of the **Land Act 1958** proclaim as road the following land:

MUNICIPAL DISTRICT OF THE  
GLENELG SHIRE COUNCIL

NARRAWONG — The land in the Parish of Narrawong shown by hatching on plan hereunder.— (3278[1 & 2] — (L2/4190)

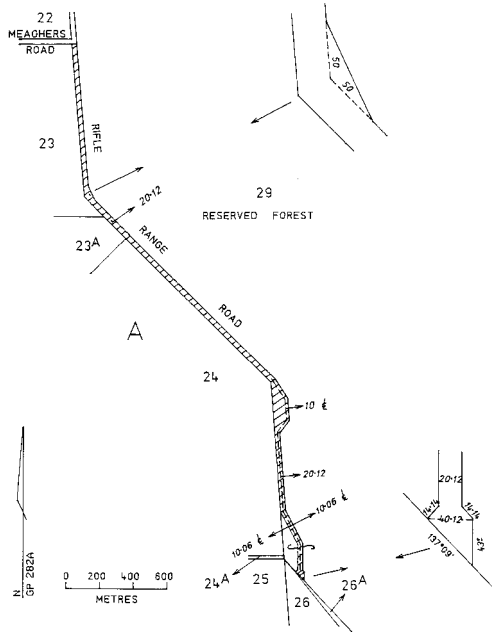

**GOVERNMENT AND OUTER BUDGET SECTOR AGENCIES  
NOTICES**

**WELLINGTON SHIRE COUNCIL**  
Proposed Road Discontinuance

The Wellington Shire Council intends to discontinue (close) a section of public road shown hatched on the plan below.

The section of road is South West of Crown Allotment 17 Section 3 in the Township of Sale.  
If discontinued, Council will sell the land from the roads to the abutting owner.

After receiving any written submissions within 14 days, which will be considered under Section 223 of the **Local Government Act 1989**, Council may decide to discontinue the road, or part of the road, or not to discontinue the road.

Submissions regarding this proposal should be addressed to the Chief Executive Officer, Wellington Shire Council, P.O. Box 506, Sale, by Friday 12 March 1999.

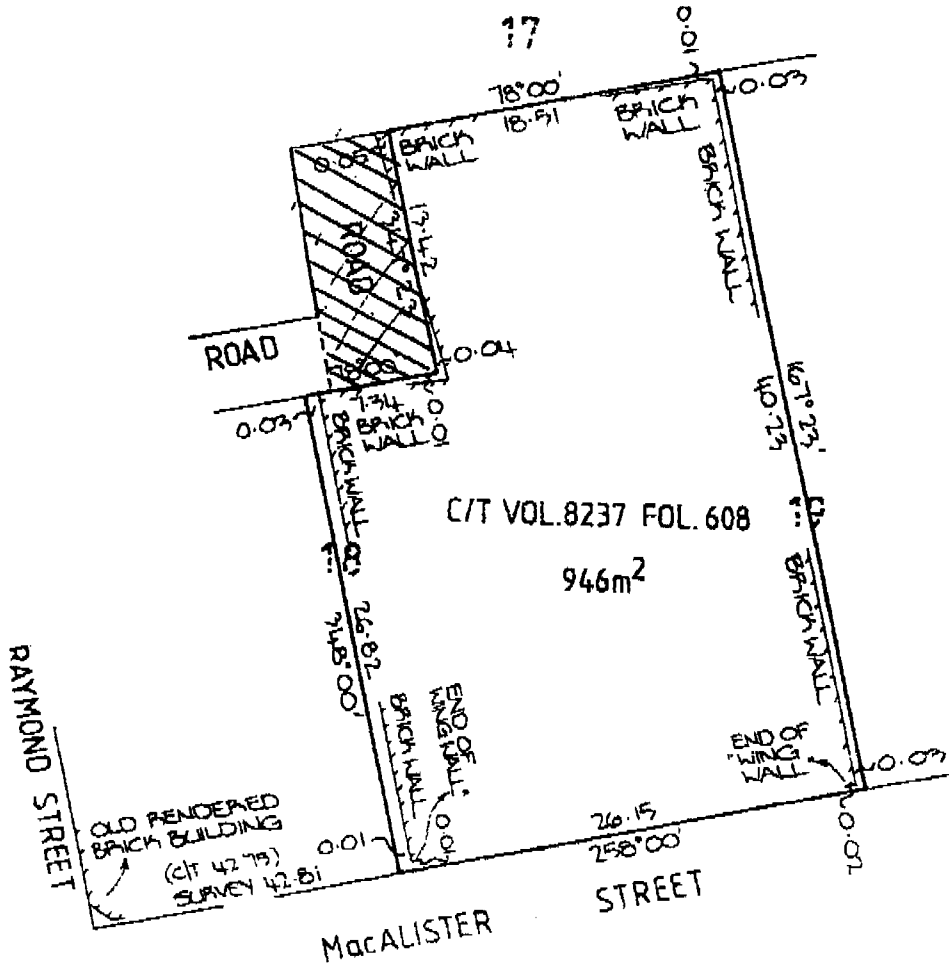

ALAN HUMPHREYS  
Chief Executive Officer

MOIRA SHIRE COUNCIL  
 Streets and Roads Local Law 1998  
 Division 2 - Control of Toy Vehicles

Moira Shire Council resolved at its ordinary meeting held on 25 January, 1999 to prohibit the use of "Toy Vehicles" in the area of the Cobram and District War Memorial situated in William Street, Cobram.

The prohibition on the Toy Vehicles is declared pursuant to clause 24 of the Streets and Roads Local Law 1998 and is designated to the area outlined in the plan and indicated by signs to be erected on the site.

The definition of "Toy Vehicle" includes a child's tricycle, scooter, skateboard, roller skates, roller blades and similar toys.

An infringement Notice penalty of \$100.00 applies.

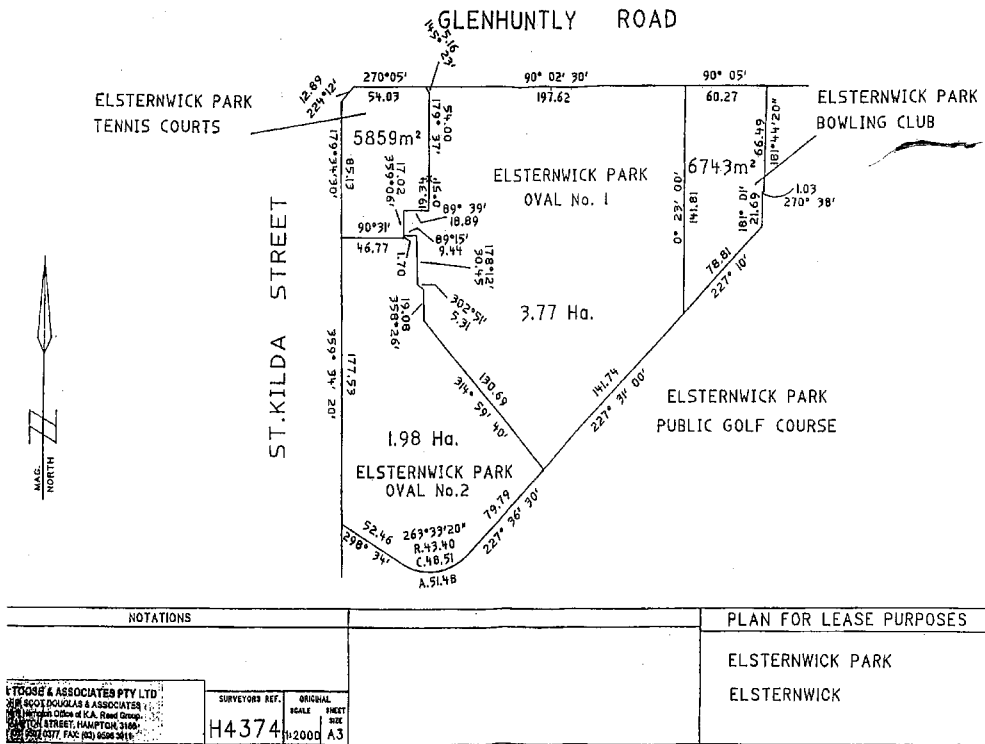

GAVIN CATOR  
 Chief Executive Officer

## MOIRA SHIRE COUNCIL

**Public Holidays Act 1993**

Moira Shire Council in accordance with Section 7(1)(b) of the **Public Holidays Act 1993**, at its Ordinary Meeting held on 25 February 1999 resolved to declare a half day (from 12 Noon) public holiday on Wednesday 20 October 1999 for the Numurkah district in observance of the Numurkah Show Day.

Further in accordance with Section 9 of the **Public Holidays Act 1993** a half day bank holiday will apply for the Numurkah district from 12 noon on Wednesday 20 October 1999.

Residents are advised that the municipal office at Numurkah will operate as normal on this day.

GAVIN CATOR  
Chief Executive Officer

## BOROUGH OF QUEENSCLIFFE

**Public Holidays Act 1993**

Notice is hereby given that the Borough of Queenscliffe appoints Thursday, October 21, 1999 as a public holiday throughout the Borough, to observe the holding of the Geelong Cup conducted by the Geelong Racing Club.

GARY PRICE  
Chief Executive Officer

## LODDON SHIRE COUNCIL

**Public Holidays Act 1993**

Pursuant to Section 7(1)(b) of the **Public Holidays Act 1993**, the Loddon Shire Council at its Ordinary Meeting held on 22 February 1999 resolved to declare a Public Holiday throughout the municipality on Tuesday 2 November 1999. (Melbourne Cup Day).

CRAIG W. NIEMANN  
Chief Executive Officer

## FRANKSTON CITY COUNCIL

## Local Law No 1 - Meeting Procedure

Notice is given pursuant to Section 119(3) of the **Local Government Act 1989** that at a meeting of the Council of Frankston City Council held on 19 January, 1999, the Council resolved to make Local Law No. 1 - Meeting Procedure.

The purpose of the Local Law is to:-

- (a) provide a mechanism to facilitate the good government of the Council;
- (b) promote and encourage community participation;
- (c) regulate and control the election of the Mayor, Deputy Mayor and the Chairperson of any Special Committees;
- (d) regulate and control procedures governing the conduct of meetings;
- (e) regulate and control the use of the Council's seal;
- (f) provide for the administration of the Council's powers and functions;
- (g) provide for the peace, order and good government of the municipal district.

Copies of the Local Law are available for inspection at the Civic Centre, Davey Street, Frankston.

JON EDWARDS  
Chief Executive Officer

## HOBSONS BAY CITY COUNCIL

## Public Notice

## Williamstown Summer Festival -

## Restrictions Relating to Alcoholic Beverages

In accordance with clause 75 (1) of its Local Law No. 2 ("the Local Law"), the Hobsons Bay City Council ("Council") has designated an area in which no person may, at any time between 6.00 p.m. Friday 26 March 1999 to midnight Sunday 28 March 1999 (inclusive), consume any alcoholic beverage or have in his or her possession any alcoholic beverage.

Council now gives notice that the area so designated is as follows:

- Nelson Place footpath and roadway area extending from Pasco Street to Syme Street (excluding any businesses which may already be permitted to serve on the footpath area outside their restaurant/cafe etc).
- Cole Street and Parker Street roadways and footpaths from Nelson Place intersection to Aitken Street intersections (excluding existing permits as above).
- Commonwealth Reserve excluding any special areas such as the Gourmet Food and Wine-tasting Tent which are designated by the Festival.

In accordance with Section 224A of the **Local Government Act 1989**, any member of the Victoria Police is authorised to enforce clause 75 of the Local Law in the designated area.

Any queries should be directed to Williamstown Summer Festival Ltd on 9397 1352.

KEN McNAMARA  
Chief Executive Officer

SURF COAST SHIRE  
Municipal Reserves & Public Places  
(Amendment)

Local Law No. 15 of 1998

Notice is hereby given that the Council of the Surf Coast Shire, at its Ordinary Meeting held on 15 February 1999, having previously complied with the relevant provisions of the **Local Government Act 1989**, adopted Local Law No. 15 of 1998 – Municipal Reserves and Public Places.

A copy of the Local Law is available for perusal at the Surf Coast Shire Offices, 25 Grossmans Road, Torquay.

JOHN WILKIN  
Acting Chief Executive Officer

**Planning and Environment Act 1987**  
SURF COAST PLANNING SCHEME  
Notice of Amendment  
Amendment R55

Torquay CFA/Emergency Services Centre

The Surf Coast Shire has prepared Amendment No. R55 to the Surf Coast Planning Scheme.

The Amendment proposes to change the Planning Scheme by reserving a 4093sqm site comprising part 25 Grossmans Road, Torquay, to 'Existing Public Purposes Reserve 19 (Ministry for Police and Emergency Services)' for the purpose of permitting the development of a joint CFA and State Emergency Services station.

The Amendment can be inspected at: Surf Coast Shire Municipal Offices, Customer Service Centre, 25 Grossmans Road, Torquay 3228; Department of Infrastructure, Office of Planning and Heritage, 63 McKillop Street, Geelong 3220 and Department of Infrastructure,

Office of Planning and Heritage, Level 3 Plaza, Nauru House, 80 Collins Street, Melbourne 3000.

Owners and occupiers of land that may be materially affected by the Amendment are entitled to make a submission. All submissions should clearly state all of the grounds on which you support or oppose the Amendment and indicate whether you wish to be heard in respect of the submission at any subsequent panel hearing.

Submissions about the Amendment must be sent to the Senior Statutory Planner, Surf Coast Shire, P.O. Box 350, Torquay 3228 by 5 April 1999.

MARK HARWOOD  
Senior Statutory Planner

**Planning and Environment Act 1987**  
MONASH PLANNING SCHEME  
Notice of Amendment

Amendment L53

Monash City Council has prepared Amendment L53 to the Monash Planning Scheme.

The Amendment applies to the land on the south east corner of Ferntree Gully and Jells Roads, Wheelers Hill, described as proposed Lot 1 PS425642N and Lot B PS427364E being part of Volume 9555 Folio 915, Volume 9555 Folio 917, Volume 9555 Folio 921, Volume 9555 Folio 923 and Volume 9555 Folio 925.

The land is currently zoned - Proposed Public Purpose - Local Government (PPP19).

The Amendment proposes to Rezone land from Proposed Public Purpose - Local Government (PPP19) to Residential C (R1).

A copy of the Amendment can be inspected during office hours, free of charge, at either the: Monash Civic Centre, 293 Springvale Road, Glen Waverley, or the Department of Infrastructure, Upper Plaza, Nauru House, 80 Collins Street, Melbourne.

Submissions about the Amendment must be sent to the Monash City Council, PO Box 1, Glen Waverley 3150 by 6 April 1999.

DAVID CONRAN  
Chief Executive Officer



**Planning and Environment Act 1987**  
MORELAND PLANNING SCHEME  
Notice of Amendment

Amendment L61

The Moreland City Council has prepared Amendment L61 to the Moreland Planning Scheme.

The Amendment extends heritage controls to additional buildings with A, B and C grade significance, two new precincts at Merlynston and Coonans Hill and some areas adjacent to existing precincts. It also deletes some precincts and parts of other precincts.

Apart from the proposed changes, other existing heritage controls remain in place and continue to apply.

The proposed heritage controls require planning permission to subdivide or consolidate land, demolish, remove, construct or carry out buildings and works, externally alter a building or paint unpainted surfaces and to construct or display a sign in relation to a listed heritage building.

Concurrent with the exhibition of this Amendment, Amendment L62 prepared and approved by the Minister for Planning and Local Government, introduces interim demolition controls during the exhibition, consideration of submissions and approval of this Amendment. The existing demolition and development controls over buildings and areas proposed to be deleted remain in place for this period.

The Amendment together with the interim controls are required to conserve and enhance those elements which contribute to the significance of heritage places and to ensure that development does not adversely affect the significance of heritage places identified in the City of Moreland Heritage Review.

The Amendment can be inspected at: Department of Infrastructure, Customer Service Centre, Upper Plaza, Nauru House, 80 Collins Street, Melbourne; Department of Infrastructure, Regional Office, 499 Ballarat Road, Sunshine and Moreland City Council, Municipal Offices, 591 Sydney Road, Coburg.

All submissions responding to the Amendment must be in writing and received by 6 April 1999 and sent to: Director City Strategy, Moreland City Council, Locked Bag 10, Moreland 3058.

Dated 24 February 1999.

ADRIAN ROBB  
Director City Strategy

**Planning and Environment Act 1987**  
STONNINGTON PLANNING SCHEME  
Notice of Amendment

Amendment L67

The Stonnington City Council has prepared Amendment L67 to the Local Section of the Stonnington Planning Scheme. The Amendment proposes to include the Rialto Area, East Malvern as a Heritage Overlay Area in the Stonnington Planning Scheme.

The purpose of the Amendment is to protect and enhance the special heritage character of the area and to ensure that any new development is in keeping with that character.

The Amendment proposes planning controls under the State Heritage Overlay over subdivision, demolition, alterations to existing buildings, construction of new buildings, front fences and painting of unpainted surfaces.

Amendment L67 can be inspected during office hours at: City of Stonnington, Customer Service Centre, corner Greville & Chapel Streets, Prahran 3181; City of Stonnington, Customer Service Centre, corner Glenferrie Road and High Street, Malvern 3144 and Department of Infrastructure, Customer Service Centre, Upper Plaza, Nauru House, 80 Collins Street, Melbourne 3000.

Submissions about the Amendment must be sent to: Bronwyn Brown, City of Stonnington, P.O. Box 21, Prahran 3181 or fax 9521 2255 by 1 April 1999.

---

**Planning and Environment Act 1987**  
STONNINGTON PLANNING SCHEME  
Notice of Amendment

Amendment L68

The Stonnington City Council has prepared Amendment L68 to the Local Section of the Stonnington Planning Scheme. The Amendment proposes to include the Williams Road Area as a Heritage Overlay Area in the Stonnington Planning Scheme.

The purpose of the Amendment is to protect and enhance the special heritage character of the area and to ensure that any new development is in keeping with that character.

The Amendment proposes planning controls under the State Heritage Overlay over subdivision,

demolition, alterations to existing buildings, construction of new buildings, front fences and painting of unpainted surfaces.

Amendment L68 can be inspected during office hours at: City of Stonnington, Customer Service Centre, corner Greville & Chapel Streets, Prahran 3181; City of Stonnington, Customer Service Centre, corner Glenferrie Road and High Street, Malvern 3144 and Department of Infrastructure, Customer Service Centre, Upper Plaza, Nauru House, 80 Collins Street, Melbourne 3000.

Submissions about the Amendment must be sent to: Bronwyn Brown, City of Stonnington, P.O. Box 21, Prahran 3181 or fax 9521 2255 by 1 April 1999.

Creditors, next of kin and others having claims against the estate of any of the undermentioned deceased persons are required to send particulars of their claims to State Trustees Limited, A.C.N 064 593 148, 168 Exhibition Street, Melbourne, Victoria, 3000 the personal representative, on or before May 6, 1999 after which date State Trustees Limited may convey or distribute the assets having regard only to the claims of which State Trustees Limited then has notice.

BEZZINA, Spiro, late of 132 Alfrieda Street, St Albans, retired, who died January 4, 1999.

BROWN, Leslie Charles, late of 13 Sapphire Street, East Preston, pensioner, who died January 21, 1999.

BUNNING, Robert, late of 35 Campbell Street, Kew East, pensioner, who died September 9, 1998.

FOREMAN, Mary Caroline, late of 2 Severn Street, Balwyn North, retiree, who died January 3, 1999.

GOCZAL, Ella, late of 26 Yorkshire Street, Pascoe Vale, pensioner, who died June 23, 1998.

KELLY, Stephen Joseph, late of Southern Cross Hostel, 288 Melbourne Road, Newport, pensioner, who died December 5, 1998.

KING, Nellie Ellen Dorothy Euphemia, late of Sir Eric Pearce House, 273 Church Street, Richmond, pensioner, who died October 22, 1998.

LANGMAID, Leslie Arthur, late of 42 Webster Street, Wycheproof, pensioner, who died September 23, 1998.

LOFT, Annie Eunice, (also known as Betty Annie Eunice Loft), late of 16 Sixth Avenue, Rosebud, pensioner, who died October 11, 1998.

Dated at Melbourne, 25 February 1999.

CATHY VANDERFEEN  
Manager, Estate Management  
State Trustees Limited

#### EXEMPTION

Application No. 126 of 1998

The Victorian Civil and Administrative Tribunal has considered an application pursuant to Section 83 of the **Equal Opportunity Act 1995** by Moonee Valley City Council; Young Mens Christian Association and Margaret Rutherford on behalf of Wingate Avenue Community Centre, in respect of the Ascot Vale Sports and Fitness centre, corner of Langs and Epsom Roads, Ascot Vale (The Centre). The application is for exemption from the operations of Sections 42, 100 and 195 of that Act. The application for exemption is to enable the Centre to be used by women only, from 8.00 p.m. to 10.00 p.m. on Saturdays, and to enable the applicants to advertise this arrangement.

Upon reading the material submitted in support of the application and upon reading and hearing submissions made in relation to the application and for the Reasons for Decision given by the Tribunal on 25 February 1999, the Tribunal is satisfied that it is appropriate to grant an exemption from Sections 42, 100 and 195 of the Act to enable the Centre to be used by women only, from 8.00 p.m. to 10.00 p.m. on Saturdays, and to enable the applicants to advertise this arrangement.

The Tribunal hereby grants an exemption to the applicants from the operation of Sections 42, 100 and 195 of the **Equal Opportunity Act 1995** to enable the Centre to be used by women only, from 8.00 p.m. to 10.00 p.m. on Saturdays, and to enable the applicants to advertise this arrangement.

This exemption is to remain in force from the day on which notice of the exemption is published in the Government Gazette until 3 March 2002.

Dated this 25 February 1999.

CATE McKENZIE  
Deputy President

N.B. A copy of the Reasons for Decision is available from the Registrar of the Anti-Discrimination List.

## EXEMPTION

## Application No. 8 of 1999

The Victorian Civil and Administrative Tribunal has considered an application pursuant to Section 83 of the **Equal Opportunity Act 1995** by Council for Adult Education for exemption from Sections 37, 42, 100 and 195 of the Act. The application for exemption is to enable the applicant to conduct each course specified in an item in the table in the Schedule, under the name specified in that item, and targeted to the group specified in that item, and to advertise that those courses are targeted for those groups.

Upon reading the material submitted in support of the application and upon hearing submissions from the Council of Adult Education and for the Reasons for Decision given by the Tribunal on 22 February 1999, the Tribunal is satisfied that it is appropriate to grant an exemption from Sections 37, 42, 100 and 195 of the Act to conduct each course specified in an item in the table in the Schedule, under the name specified in that item, and targeted to the group specified in that item, and to advertise that those courses are targeted for those groups.

The Tribunal hereby grants an exemption to the applicant from the operation of Sections 37, 42, 100 and 195 of the **Equal Opportunity Act 1995** to enable the applicant to conduct each course specified in an item in the table in the Schedule, under the name specified in that item, and targeted to the group specified in that item, and to advertise that those courses are targeted for those groups. This exemption does not authorise the applicant to exclude from any course a person who is not part of the group targeted for that course.

SCHEDULE

ITEM NUMBER	COURSE TITLE	TARGETED GROUP
1	Computers for Women	Women
2	Stock Market for Women	Women
3	Fertility-Knowledge, Choices and Well-Being	Women
4	Feldenkrais Awareness Through Movement	Women
5	Self Defence for Women	Women
6	Self Confidence and Assertion for Women	Women
7	Weekend Escape for Women	Women
8	Surfing Day for Women	Women
9	Computers Made Easy	Age over 50 years
10	Introduction to Windows 95	Age over 50 years
11	Learn to Type Quick	Age over 50 years
12	Word Processing 97	Age over 50 years
13	Learn the Internet	Age over 50 years
14	Apple Mac Made Easy	Age over 50 years
15	Exercise with Ease	Age 50 years and over
16	Keep Fit In Retirement	Age 50 years and over
17	Gentle Exercise to Music	Age 50 years and over

18	Over 40's Career Options	Age over 40 years
19	Self Defence For Men	Men
20	Massage For Couples	Couples
21	Flying Solo	Singles
22	Singles At Christmas	Singles
23	Improve your reading, Writing and Maths	Those with a mild intellectual impairment

This exemption is to remain in force from the day on which notice of the exemption is published in the Government Gazette until 3 March 2002.

CATE McKENZIE  
Deputy President

N.B. A copy of the Reasons for Decision is available from the Registrar of the Anti-Discrimination List.

Department of Treasury and Finance  
SALE OF CROWN LAND  
BY PUBLIC AUCTION

**Reference:** 97/03925.

**Date of Auction:** Wednesday 31 March 1999 at  
3.00 p.m. on site.

**Address of Property:** Dorcas Street, South  
Melbourne.

**Crown Description:** Allotment 4, Section 10,  
Parish of Melbourne South.

**Terms of Sale:** 10% Deposit, balance 60 days.

**Area:** 1,829 m<sup>2</sup>.

**Officer Co-ordinating Sale:** Brian Dee, Senior  
Project Manager, Victorian Government  
Property Group, Level 10, 1 Macarthur  
Street, Melbourne, Department of Treasury  
and Finance.

**Selling Agent:** Klinger Wood Real Estate Pty  
Ltd, 250 Queen Street, Melbourne, Vic.  
3000.

ROGER M. HALLAM  
Minister for Finance

Department of Treasury and Finance  
SALE OF CROWN LAND  
BY PUBLIC AUCTION

**Date of Auction:** 10.45 a.m. Saturday 17 April  
1999.

**Reference No:** 98/02701.

**Address of Property:** Herriot Street, Heathcote.

**Crown Description:** Allotment 6A, Section 4B,  
Parish of Heathcote.

**Terms of Sale:** Deposit 10%, Balance 60 days.

**Area:** 6.887 hectares.

**Officer Co-ordinating Sale:** Peter Hollins,  
Victorian Government Property Group,  
Department of Treasury and Finance, 10/1  
Macarthur Street, Melbourne, Vic. 3002.

**Selling Agent:** Connally's Real Estate.

ROGER M. HALLAM  
Minister for Finance

Department of Treasury and Finance  
SALE OF CROWN LAND  
BY PUBLIC AUCTION

**Date of Auction:** 2.00 p.m. Wednesday 24  
March 1999.

**Reference No:** 98/02955.

**Address of Property:** Murphy Street, Bendigo.

**Crown Description:** Allotment 113B, Section  
O, Parish of Sandhurst.

**Terms of Sale:** Deposit 10%, Balance 60 days.

**Area:** 0.878 hectares.

**Officer Co-ordinating Sale:** Peter Hollins,  
Victorian Government Property Group,  
Department of Treasury and Finance, 10/1  
Macarthur Street, Melbourne, Vic. 3002.

**Selling Agent:** Curnow Dyett, Killains Walk  
Bendigo.

ROGER M. HALLAM  
Minister for Finance

Department of Treasury and Finance

SALE OF CROWN LAND

BY PUBLIC AUCTION

**Date of Auction:** 10.00 a.m. Saturday 20 March 1999.

**Reference No:** 98/02702.

**Address of Property:** corner Maiden Gully Road & Butler Street, Maiden Gully.

**Crown Description:** Allotment 458D, Section M, Parish of Sandhurst.

**Terms of Sale:** Deposit 10%, Balance 60 days.

**Area:** 0.246 hectares.

**Officer Co-ordinating Sale:** Peter Hollins, Victorian Government Property Group, Department of Treasury and Finance, 10/1 Macarthur Street, Melbourne, Vic. 3002.

**Selling Agent:** Curnow Dyett, Killains Walk Bendigo.

ROGER M. HALLAM  
Minister for Finance

---

Department of Treasury and Finance

SALE OF CROWN LAND

BY PUBLIC AUCTION

**Date of Auction:** 10.30 a.m. Saturday 17 April 1999.

**Reference No:** 98/02705.

**Address of Property:** Back Kyneton Road, Heathcote.

**Crown Description:** Allotment 8A, Section 7A, Parish of Heathcote.

**Terms of Sale:** Deposit 10%, Balance 60 days.

**Area:** 12.2 hectares.

**Officer Co-ordinating Sale:** Peter Hollins, Victorian Government Property Group, Department of Treasury and Finance, 10/1 Macarthur Street, Melbourne, Vic. 3002.

**Selling Agent:** Connally's Real Estate.

ROGER M. HALLAM  
Minister for Finance

---

Department of Treasury and Finance

SALE OF CROWN LAND

BY PUBLIC AUCTION

**Date of Auction:** 10.45 a.m. Saturday 20 March 1999.

**Reference No:** 98/02713.

**Address of Property:** off Thomas & Esler Streets, Eaglehawk.

**Crown Description:** Allotment 91F, Section M, Parish of Sandhurst.

**Terms of Sale:** Deposit 10%, Balance 60 days.

**Area:** 0.073 hectares.

**Officer Co-ordinating Sale:** Peter Hollins, Victorian Government Property Group, Department of Treasury and Finance, 10/1 Macarthur Street, Melbourne, Vic. 3002.

**Selling Agent:** Curnow Dyett, Killains Walk Bendigo.

ROGER M. HALLAM  
Minister for Finance

---

Department of Treasury and Finance

SALE OF CROWN LAND

BY PUBLIC AUCTION

**Date of Auction:** 11.15 a.m. Saturday 27 March 1999.

**Reference No:** 98/02723.

**Address of Property:** Newton Street, Eaglehawk.

**Crown Description:** Allotment 16, Section 1B, Parish of Nerring.

**Terms of Sale:** Deposit 10%, Balance 60 days.

**Area:** 0.100 hectares.

**Officer Co-ordinating Sale:** Peter Hollins, Victorian Government Property Group, Department of Treasury and Finance, 10/1 Macarthur Street, Melbourne, Vic. 3002.

**Selling Agent:** Curnow Dyett, Killains Walk Bendigo.

ROGER M. HALLAM  
Minister for Finance

---

Department of Treasury and Finance

SALE OF CROWN LAND

BY PUBLIC AUCTION

**Date of Auction:** 10.30 a.m. Saturday 27 March 1999.

**Reference No:** 98/02724.

**Address of Property:** Sailors Gully Road & Cook Street, Eaglehawk.

**Crown Description:** Allotment 17, Section 2B, Parish of Nerring.

**Terms of Sale:** Deposit 10%, Balance 60 days.

**Area:** 1.044 hectares.

**Officer Co-ordinating Sale:** Peter Hollins, Victorian Government Property Group, Department of Treasury and Finance, 10/1 Macarthur Street, Melbourne, Vic. 3002.

**Selling Agent:** Curnow Dyett, Killains Walk Bendigo.

ROGER M. HALLAM  
Minister for Finance

---

Department of Treasury and Finance

SALE OF CROWN LAND  
BY PUBLIC AUCTION

**Date of Auction:** 10.00 a.m. Saturday 27 March 1999.

**Reference No:** 98/02725.

**Address of Property:** Letheby's Road & Stewart Street, Eaglehawk.

**Crown Description:** Allotment 260A, Section A, Parish of Nerring.

**Terms of Sale:** Deposit 10%, Balance 60 days.

**Area:** 0.283 hectares.

**Officer Co-ordinating Sale:** Peter Hollins, Victorian Government Property Group, Department of Treasury and Finance, 10/1 Macarthur Street, Melbourne, Vic. 3002.

**Selling Agent:** Curnow Dyett, Killains Walk Bendigo.

ROGER M. HALLAM  
Minister for Finance

---

Department of Treasury and Finance

SALE OF CROWN LAND  
BY PUBLIC AUCTION

**Date of Auction:** 11.30 a.m. Saturday 20 March 1999.

**Reference No:** 98/02726.

**Address of Property:** Brown Street, Eaglehawk.

**Crown Description:** Allotment 302G, Section M, Parish of Sandhurst.

**Terms of Sale:** Deposit 10%, Balance 60 days.

**Area:** 0.095 hectares.

**Officer Co-ordinating Sale:** Peter Hollins, Victorian Government Property Group, Department of Treasury and Finance, 10/1 Macarthur Street, Melbourne, Vic. 3002.

**Selling Agent:** Curnow Dyett, Killains Walk Bendigo.

ROGER M. HALLAM  
Minister for Finance

Department of Treasury and Finance

SALE OF CROWN LAND  
BY PUBLIC AUCTION

**Date of Auction:** 12.15 p.m. Saturday 20 March 1999.

**Reference No:** 98/02727.

**Address of Property:** corner McCormacks Road & Bracewell Street. Eaglehawk.

**Crown Description:** Allotment 391A, Section M, Parish of Sandhurst.

**Terms of Sale:** Deposit 10%, Balance 60 days.

**Area:** 2.163 hectares.

**Officer Co-ordinating Sale:** Peter Hollins, Victorian Government Property Group, Department of Treasury and Finance, 10/1 Macarthur Street, Melbourne, Vic. 3002.

**Selling Agent:** Curnow Dyett, Killains Walk Bendigo.

ROGER M. HALLAM  
Minister for Finance

---

Department of Treasury and Finance

SALE OF CROWN LAND  
BY PUBLIC AUCTION

**Date of Auction:** 12 Noon Saturday 27 March 1999.

**Reference No:** 98/02960.

**Address of Property:** corner Pitt Street & Sawmill Road, Huntly.

**Crown Description:** Allotment 11E, Section 18, Parish of Huntly.

**Terms of Sale:** Deposit 10%, Balance 60 days.

**Area:** 6.55 hectares.

**Officer Co-ordinating Sale:** Peter Hollins, Victorian Government Property Group, Department of Treasury and Finance, 10/1 Macarthur Street, Melbourne, Vic. 3002.

**Selling Agent:** Curnow Dyett, Killains Walk Bendigo.

ROGER M. HALLAM  
Minister for Finance

---

Department of Treasury and Finance

SALE OF CROWN LAND  
BY PUBLIC AUCTION

**Date of Auction:** 2.45 p.m. Wednesday 24 March 1999.

**Reference No:** 98/02733.

**Address of Property:** Rowena and Murphy Street, Bendigo East.

**Crown Description:** Allotment 240S, Section O, Parish of Sandhurst.

**Terms of Sale:** Deposit 10%, Balance 60 days.

**Area:** 2.276 hectares.

**Officer Co-ordinating Sale:** Peter Hollins, Victorian Government Property Group, Department of Treasury and Finance, 10/1 Macarthur Street, Melbourne, Vic. 3002.

**Selling Agent:** Curnow Dyett, Killains Walk Bendigo.

ROGER M. HALLAM  
Minister for Finance

### Children and Young Persons Act 1989

#### APPOINTMENT OF HONORARY PROBATION OFFICERS

I, Pam White, Regional Director of Department of Human Services Eastern Region, under Section 34(4) of the **Children and Young Persons Act 1989** appoint the undermentioned persons as Honorary Probation Officers for the Children's Court in the State of Victoria for the period ending 31 December 2001.

Phyllis Ward  
Shelley Garrett  
Cherry Fuller  
Christine Buckingham  
Edna Strachan  
Max Hall  
Ian Hellings  
Julie Singles  
Dr Eve Addis  
Elizabeth Birch  
Terry Cummins  
Keith Pocklington  
Dan Phelan  
Denise Melville  
Alexina Baldini

PAM WHITE  
Regional Director

### Country Fire Authority Act 1958

#### VARIATION OF FIRE DANGER PERIOD

In pursuance of the powers conferred by Section 4 of the **Country Fire Authority Act 1958**, I, Leonard Raymond Foster, Chairman of

the Country Fire Authority, after consultation with the Secretary of Natural Resources and Environment, hereby vary the declaration of the Fire Danger Periods previously published in the Government Gazette by declaring that such Fire Danger Periods shall end in respect of the undermentioned Municipal Districts of Municipalities or parts of Municipalities specified.

To terminate from 01.00 hours on Tuesday 9 March, 1999:

Mildura Rural City Council  
Swan Hill Rural City Council  
Yarriambiack Shire Council  
Buloke Shire Council  
Gannawarra Shire Council  
Loddon Shire Council (Northern Part). That part north of a line commencing on the western boundary of the Shire travelling easterly along the Borung-Charlton Road to Borung then along the Borung-Hurstwood Road to the Loddon River, then generally southerly along the Loddon River to the Bridgewater-Serpentine Road, then along Foleys Road to the Loddon Valley Highway, then northerly to Rothakers Road, then continue east along Rothakers Road and Tandarra-Serpentine Road then south along Thompsons Road then east along Tandarra-Elmore Road and Steads Road to the Shire's eastern boundary.

Hindmarsh Shire Council

Rural City of Horsham (Part). That part north of the line described by the following roads:- Bow Lake Fire Access Road, Bow Lake Road, Jallumba/Clear Lake Road, Jallumba/Mockinya Road, Wonwondah/Toolondo Road, North East Wonwondah Road, Grampians Road, Wonwondah/Dadswell Bridge Road, Fulbrooks Road to the Wimmera River.

West Wimmera Shire Council (Part). That part north of the line described by the following roads:- Elliots Road, Northern Break, McDonald Highway.

To terminate from 01.00 hours on Monday 15 March, 1999:

Baw Baw Shire Council  
South Gippsland Shire Council  
Wellington Shire Council  
Latrobe Shire Council

L. FOSTER  
Chairman

**Geographic Place Names Act 1998**

## 1. NOTICE OF REGISTRATION OF GEOGRAPHIC NAMES

The Registrar of Geographic Names hereby gives notice of the registration of the undermentioned place names.

<b>File No.</b>	<b>Place Name</b>	<b>Proposer &amp; Location</b>
1676	Anakie, Avalon, Balliang, Barwon Heads, Batesford, Bell Park, Bell Post Hill, Bellarine, Belmont, Breakwater, Breamlea, Ceres, Clifton Springs, Connemara, Corio, Curlewis, Drumcondra, Drysdale, Fyansford, Geelong, Geelong East, Geelong North, Geelong South, Geelong West, Grovedale, Hamlyn Heights, Herne Hill, Highton, Indented Head, Lara, Leopold, Little River, Lovely Banks, Manifold Heights, Mannerim, Marcus Hill, Marshall, Moolap, Moorabool, Mount Duneed, Newcomb, Newtown, Norlane, North Shore, Ocean Grove, Point Lonsdale, Point Wilson, Portarlington, Rippleside, St. Albans Park, St. Leonards, Staughton Vale, Swan Bay, Thomson, Wandana Heights, Wallington, Waurm Ponds and Whittington.	City of Greater Geelong. Assignment of the 58 aforementioned suburbs and rural localities within the municipality. Plans may be inspected at the Municipal Offices, Department of Natural Resources and Environment Geelong, or the Office of the Registrar of Geographic Names.
1679	Blackburn, Blackburn North, Blackburn South, Box Hill, Box Hill North, Box Hill South, Burwood, Burwood East, Forest Hill, Mitcham, Mont Albert, Mont Albert North, Nunawading, Surrey Hills, Vermont and Vermont South.	City of Whitehorse. Assignment of the 16 aforementioned suburbs locality names and boundaries within the municipality. The plans showing the names and boundaries may be inspected at the Municipal Offices, or the Office of the Registrar of Geographic Names.
1651	Ashwood, Burwood, Chadstone, Clayton, Glen Waverley, Hughesdale, Huntingdale, Mount Waverley, Mulgrave, Notting Hill, Oakleigh, Oakleigh East, Oakleigh South and Wheelers Hill.	City of Monash. Assignment of the 14 aforementioned suburbs within the municipality. Plans may be inspected at the Municipal Offices, or the Office of the Registrar of Geographic Names.
1726	Slim Blaby Park	Rural City of Mildura. A previously unnamed municipal reserve situated at then end of Delamere Court Merebin.
1730	George Bass Cove	Bass Coast Shire Council. A previously unnamed coastal area situated approximately 800 metres south of San Remo.
1733	Halley Supple Reserve	Yarra Ranges Shire Council. A previously unnamed municipal reserve bounded by the North and South Gateway, Coldstream.



1733	Margaret Lewis Reserve	Yarra Ranges Shire Council. A previously unnamed municipal reserve situated off Ingram Road, Coldstream.
1733	Glenhurst Park	Yarra Ranges Shire Council. A previously unnamed municipal reserve situated off Welten Drive, Colestream.
1804	Kiah Reserve	Wyndham City Council. A previously unnamed municipal reserve situated at the corner of Maple and Grevillea Crescents, Hoppers Crossing.

## 2. AMENDMENT OF AN ENTRY IN THE REGISTER OF GEOGRAPHIC NAMES

File No.	Place Name	Proposer & Location
1807	From You Yangs Rd Reserve to Mc Naughton Reserve.	Wyndham City Council - Situated South of You Yangs Rd, adjacent to Grant Bridge Little River.

Office of Registrar of Geographic Names  
c/- LAND VICTORIA  
2nd Floor  
456 Lonsdale Street  
MELBOURNE 3000

JOHN PARKER  
Registrar Geographic Names

**Private Agents Act 1966****NOTICE OF RECEIPT OF APPLICATIONS FOR LICENCES UNDER THE PROVISIONS OF THE PRIVATE AGENTS ACT 1966**

I, the undersigned, being the Registrar of the Cobram Magistrates' Court hereby give notice that applications, as under have been lodged for hearing by the said Court on the date specified.

Any person desiring to object to any such application must:

- (a) lodge with me a notice in the prescribed form of his objection and of the grounds thereof;
- (b) cause a copy of such notice to be served personally or by post upon the applicant at least three days before the hearing of the application; and
- (c) send or deliver
  - (i) where the objection is not made by the officer in charge of the police district in which the Court is situated — a copy of the notice to such officer; and
  - (ii) where the objection is not made by the Registrar or Deputy Registrar — a copy to the Registrar.

<i>Full name of Applicant or in the case of a Firm or Corporation, of the Nominee</i>	<i>Place of Abode of Applicant or Nominee</i>	<i>Name of Firm or Corporation</i>	<i>Address for Registration</i>	<i>Type of Licence</i>	<i>Date of Hearing of Application</i>
Merrick Birchall	74 Telford Street, Yarrowonga, (P.O. Box 76) 3730	Howard Alexander Jackson	74 Telford Street, Yarrowonga, (P.O. Box 76) 3730	Commercial Sub-agent	31 March 1999

Dated 16 February 1999.

DAVID SMITH  
Registrar of Cobram Magistrates' Court

**Private Agents Act 1966****NOTICE OF RECEIPT OF APPLICATIONS FOR LICENCES UNDER THE PROVISIONS OF THE PRIVATE AGENTS ACT 1966**

I, the undersigned, being the Deputy Registrar of the Melbourne Magistrates' Court hereby give notice that applications, as under have been lodged for hearing by the said Court on the date specified.

Any person desiring to object to any such application must:

- (a) lodge with me a notice in the prescribed form of his objection and of the grounds thereof;
- (b) cause a copy of such notice to be served personally or by post upon the applicant at least three days before the hearing of the application; and
- (c) send or deliver
  - (i) where the objection is not made by the officer in charge of the police district in which the Court is situated — a copy of the notice to such officer; and
  - (ii) where the objection is not made by the Registrar or Deputy Registrar — a copy to the Registrar.

<i>Full name of Applicant or in the case of a Firm or Corporation, of the Nominee</i>	<i>Place of Abode of Applicant or Nominee</i>	<i>Name of Firm or Corporation</i>	<i>Address for Registration</i>	<i>Type of Licence</i>	<i>Date of Hearing of Application</i>
Craig Anton Lielups	100 Union Street, Northcote	B. & F. Associates	160 Jonston Street, Fitzroy 3065	Commercial Sub-agent	4 April 1999
Gloria Kiri	3 Claremont Avenue Malvern	Trace Detective Agency	3 Claremont Avenue Malvern	Commercial Sub-agent	4 April 1999
Stuart John Mayne	730 Pascoe Vale Road, Glenroy 3046	State Wide Enquiry Services P/L	Level 5, 221 Queen Street, Melbourne	Commercial Sub-agent	4 April 1999
Thomas Malcolm Harold Daykin	30 Terama Crescent, Bayswater, Victoria 3153	B. & F. Associates	160 Jonston Street, Fitzroy 3065	Commercial Sub-agent	4 April 1999
Advanced Credit Management (Vic.) Pty Ltd	Level 5, 455 Bourke Street, Melbourne, Vic. 3000	Vicira Lech & Co.	Level 5, 455 Bourke Street, Melbourne, Vic. 3000	Commercial agent	4 April 1999
Citibureau Collections P/L	9th Floor, 14 Queens Road, Melbourne, Vic. 3004	Citibureau Collections P/L	9th Floor, 14 Queens Road, Melbourne, Vic. 3004	Commercial agent	4 April 1999
Commercial Protection Services Pty Ltd	Level 1, 313-317 Kingsway, South Melbourne, Vic. 3205	Commercial Protection Services Pty Ltd	Level 1, 313-317 Kingsway, South Melbourne, Vic. 3205	Commercial agent	4 April 1999

Dated 4 March 1999

PETER MITHEN  
Deputy Registrar of Melbourne Magistrates' Court

**Water Act 1989**DECLARATION OF THE CREATION OF  
THE WANDONG HEATHCOTE JUNCTION  
SEWERAGE DISTRICT ORDER 1998

1. This Order is called the Declaration of the Wandong Heathcote Junction Sewerage District - Order 1999.
2. This Order is made under Section 96(11)(a) of the **Water Act 1989** and all other available powers.
3. This Order takes effect from the date it is published in the Government Gazette.
4. The proposal for the declaration of a new sewerage district submitted to the Department of Natural Resources and Environment by the Goulburn Valley Region Water Authority on 8 December, 1998 is approved by the Minister.
5. (a) A new sewerage district is declared;
- (b) The new sewerage district is called Wandong Heathcote Junction Sewerage District;
- (c) The Wandong Heathcote Junction Sewerage District is the land within the red border on the accompanying plan No. JS628, a copy of which may be inspected at the offices of the Goulburn Valley Region Water Authority, situated at 104-110 Fryers Street, Shepparton or Hume and Hovell Streets, Seymour, Victoria; and
- (d) The Goulburn Valley Region Water Authority is nominated to manage and control the Wandong Heathcote Junction Sewerage District.

Dated 25 February, 1999.

L. J. GLEESON  
Chief Executive**Water Act 1989**DECLARATION OF EXTENSION TO THE  
BONNIE DOON SEWERAGE DISTRICT  
ORDER 1998

6. This Order is called the Declaration of the Bonnie Doon Sewerage District - Order 1999.
7. This Order is made under Section 96(11)(a) of the **Water Act 1989** and all other available powers.

8. This Order takes effect from the date it is published in the Government Gazette.
9. The proposal for the declaration of a new sewerage district submitted to the Department of Natural Resources and Environment by the Goulburn Valley Region Water Authority on 24 December, 1998 is approved by the Minister.
10. (a) A new sewerage district is declared;
- (e) The new sewerage district is called Bonnie Doon Sewerage District;
- (f) The Bonnie Doon Sewerage District is the land within the red border on the accompanying plan No. JW628, a copy of which may be inspected at the offices of the Goulburn Valley Region Water Authority, situated at 104-110 Fryers Street, Shepparton or Hume and Hovell Streets, Seymour, Victoria; and
- (g) The Goulburn Valley Region Water Authority is nominated to manage and control the Bonnie Doon Sewerage District.

Dated 25 February, 1999.

L. J. GLEESON  
Chief Executive**Water Act 1989**DECLARATION OF THE CREATION OF  
THE MERRIGUM SEWERAGE DISTRICT  
ORDER 1998

11. This Order is called the Declaration of the Merrigum Sewerage District - Order 1999.
12. This Order is made under Section 96(11)(a) of the **Water Act 1989** and all other available powers.
13. This Order takes effect from the date it is published in the Government Gazette.
14. The proposal for the declaration of a new sewerage district submitted to the Department of Natural Resources and Environment by the Goulburn Valley Region Water Authority on 27 November, 1998 is approved by the Minister.
15. (a) A new sewerage district is declared;
- (h) The new sewerage district is Merrigum Sewerage District;
- (i) The Merrigum Sewerage District is the land within the red border on the

accompanying plan No. OIC-Merrigum Sewer, a copy of which may be inspected at the offices of the Goulburn Valley Region Water Authority, situated at 104-110 Fryers Street, Shepparton or Hume and Hovell Streets, Seymour, Victoria; and

- (j) The Goulburn Valley Region Water Authority is nominated to manage and control the Bonnie Doon Sewerage District.

Dated 25 February, 1999.

L. J. GLEESON  
Chief Executive

#### **Water Act 1989**

##### DECLARATION OF EXTENSION TO THE MERRIGUM WATER DISTRICT ORDER 1998

16. This Order is called the Declaration of the Merrigum Water District - Order 1999.
17. This Order is made under Section 96(11)(a) of the **Water Act 1989** and all other available powers.
18. This Order takes effect from the date it is published in the Government Gazette.
19. The proposal for the declaration of a new water district submitted to the Department of Natural Resources and Environment by the Goulburn Valley Region Water Authority on 27 November, 1998 is approved by the Minister.
20. (a) A new water district is declared;
- (k) The new water district is Merrigum Water District;
- (l) The Merrigum Water District is the land within the red border on the accompanying plan No. OIC-Merrigum Water, a copy of which may be inspected at the offices of the Goulburn Valley Region Water Authority, situated at 104-110 Fryers Street, Shepparton Victoria; and
- (m) The Goulburn Valley Region Water Authority is nominated to manage and control the Merrigum Water District.

Dated 25 February, 1999.

L. J. GLEESON  
Chief Executive

#### **Water Act 1989**

I, Patrick McNamara, Minister for Agriculture and Resources and Minister responsible for administering the **Water Act 1989**, make the following Order:

Dated 22 February 1999.

PATRICK McNAMARA  
Minister for Agriculture and Resources

##### **EXTENSION OF THE SNOWY RIVER MANAGEMENT DISTRICT ORDER 1999**

###### 1. *Title*

This Order is called the Extension of the Snowy River Management District Order 1999.

###### 2. *Authorising Provision*

This Order is made under Division 2 of Part 6 of the **Water Act 1989** and all other available powers.

###### 3. *Commencement*

This Order comes into operation on the date on which it is published in the Government Gazette.

###### 4. *Extension of the Snowy River Management District*

- (1) The proposal for the extension of the Snowy River Management District submitted to me by the East Gippsland Catchment Management on 29 January 1999 is approved.
- (2) The Snowy River Management District is extended to include the area bordered red on the accompanying four plans, Nos IDA-3319, 3320, 3321 and 3322. A copy of these plans may be inspected at the offices of the East Gippsland Catchment Management Authority at 3/107 Nicholson Street, Bairnsdale.

#### **Land Act 1958**

“Notice is hereby given that the Inverleigh Golf Club Inc. has applied for a lease pursuant to Section 134 of the **Land Act 1958**. For a term of 21 years in respect of Crown Allotment 15C, Parish of Carrah containing approximately 57 Hectares more or less situated at Common Road, Inverleigh, for the purpose of golf club and associated purposes therewith”.

**Adoption Act 1984 Section 21**APPLICATION FOR APPROVAL AS AN  
ADOPTION AGENCY

Under the provisions of Section 10(2) of the **Community Services Act 1970** I have been assigned the functions and powers of the Secretary of Department of Human Services under Section 22 of the **Adoption Act 1984**.

The following welfare organisation has applied for approval as an adoption agency.

Westate Community Development Limited  
175-187 Hargreaves Street,  
Bendigo 3550.

Principal Officer: Jennifer Hocking.

Dated: 1 March 1999.

YEHUDI BLACHER

Director

Youth and Family Services

**Nurses Act 1993**

## NURSES BOARD OF VICTORIA

On 28 January 1999, a panel appointed by the Nurses Board of Victoria, found that Gavin Bernard Williams of RMB 2028, Baddaginnie, Victoria, identification number 82739, registered in division 3, had engaged in unprofessional conduct of a serious nature.

The panel determines that:-

1. Pursuant to s. 48(2)(g) **Nurses Act 1993**, the nurse's registration be suspended with effect from 4 March 1999.
2. After 4 September 1999, the nurse must apply in writing to remove the suspension of his registration, but only if the following conditions are and have been observed.
  - (a) From 4 March 1999, until the suspension is removed, the nurse must not work, in any capacity, for:
    - (i) a registered funded agency; nor
    - (ii) a health service establishment as those terms are defined in s. 3 **Health Services Act 1988** of Victoria nor as or for a nurse's agent, as defined in s. 3 **Nurses Act 1993**.
  - (b) Pursuant to s. 48(2)(a) **Nurses Act 1993**, the nurse must undergo counselling and consultations with a psychiatrist or other counsellor ("counsellor") approved

in writing by the Board, the first consultation to occur by 4 April 1999, with consultations to occur at least once a month thereafter, or more often if the counsellor so directs.

- (c) Pursuant to s. 48(2)(b) **Nurses Act 1993**, the nurse must enrol in and satisfactorily complete by 30 June 2000 a post-graduate unit in professional issues and psychiatric nursing, the course and institution chosen to be approved in writing by the Board before the course commences.
- (d) With his application to remove the suspension of his registration, the nurse must produce to the Board:-
  - (i) a report by the counsellor of the counselling and consultations referred to in sub-paragraph (b), which report must be satisfactory to the Board; and
  - (ii) evidence of compliance with the condition imposed by sub-paragraph (c).

BARBARA CARTER  
Acting Chief Executive  
Nurses Board of Victoria

**Nurses Act 1993**

## NURSES BOARD OF VICTORIA

On 28 January 1999, a panel appointed by the Nurses Board of Victoria, found that Dex Benedict Kelly of P.O. Box 388, Brunswick, Victoria, identification number 94049, registered in division 3, had engaged in unprofessional conduct of a serious nature.

The panel determines that:-

1. Pursuant to s. 48(2)(d) **Nurses Act 1993**, the nurse must enrol in, and produce to the Board by 30 June 2000 evidence of satisfactory completion of, a post-graduate course module on professional issues in psychiatric nursing, the course module and institution to be approved in writing by the Board before the course commences.

BARBARA CARTER  
Acting Chief Executive  
Nurses Board of Victoria

**Transport Act 1983****VICTORIAN TAXI DIRECTORATE**

## Department of Infrastructure

## Commercial Passenger Vehicle Applications

Notice is hereby given that the following applications will be considered by the Victorian Taxi Directorate, a division of the Department of Infrastructure after 7 April 1999.

Notice of any objection to the granting of an application should be forwarded to reach the Manager, Licensing & Certification, Victorian Taxi Directorate, Level 6, 14-20 Blackwood Street, North Melbourne (P.O. Box 666, North Melbourne 3051) not later than 1 April 1999.

Copies of objections are forwarded to the applicants.

It will not be necessary for interested parties to appear on the date specified, unless advised in writing by the Department.

Deluxe Coachlines Pty Ltd, Cheltenham. Application to license one commercial passenger vehicle to be purchased in respect of a 1996 or later model Toyota or Chrysler van with seating capacity for 7 passengers to operate a service from 2/20 Kylie Place, Cheltenham for the carriage of interstate and overseas passengers to various tourist places of interest throughout the State of Victoria where the use of a driver/tour commentator is an integral feature of the hiring.

Note:-

- (i) Passengers will be picked up/set down throughout the State of Victoria.
- (ii) Applicant will operate in conjunction with Deluxe Coachlines Pty Ltd and Getaway Tours.

Deluxe Coachlines Pty Ltd, Cheltenham. Application for variation of conditions of licence TO192 which authorises the licensed vehicle to operate as a touring omnibus along the routes specified in the 'Schedule of Tours' hereunder subject to the following conditions:-

- (a) The route and duration of any tour authorised to be operated thereon as defined in 1 the said schedule shall be adhered to at all times and no deviation made thereon except in pursuance of a permit issued by VicRoads.
- (b) Except where otherwise stated in the said schedule each tour shall be opened solely as

a round tour, that is to say - every passenger shall be carried for the complete journey and shall join and finally leave the vehicle at the place named in the said schedule as the place from which the tour is to commence.

- (c) A passenger shall be deemed to have commenced any tour at the authorised place of commencement who joins the vehicle at any place within a radius of 20km from the Melbourne G.P.O.
- (d) Every passenger travelling on any tour shall be charged the full fare as may be specified for the particular tour in the said schedule. Except where otherwise stated, the fare shall only be for road travel.
- (e) That no tour shall operate to Phillip Island, Ballarat, City of Melbourne and the observatory reserve at the summit of Mt Dandenong.

**NOTE:** The City of Melbourne, Ballarat and Phillip Island are defined by its municipal or shire boundaries.

- (f) That the number of tours undertaken shall not exceed 24 each calendar of year.

**SCHEDULE OF TOURS**

The only passengers that may be carried on "TOURS" shall be artists, photographers, field naturalist and birdwatchers from Melbourne to points of interest throughout Victoria.

**DURATION OF TOURS:**

Tours will vary in length from two to thirty days and will be decided upon with hiring party.

The licensed vehicle may also operate under charter condition from within a 20km radius of the Melbourne GPO in accordance with schedules 1, 2, 3 attached.

To vary the above condition; and

To instead operate under charter conditions from within a 55km pick-up radius of the Melbourne GPO.

M. & A. Ghersetti and S. & B. O'Regan, Reservoir. Application for variation of conditions of licence SV1251 which authorises the licensed vehicle to operate in respect of a 1968-79 Jaguar/Daimler convertible or sedan with seating capacity of 12 or fewer seats to change the vehicle to a 1988 or later model Ford Fairlane/LTD sedan with seating capacity of 12 or fewer seats.

V. Mifsud, Delahey. Application for variation of conditions of licence SV1075 which authorises the licensed vehicle to operate in respect of a 1974 Jaguar sedan with seating capacity of 12 or fewer seats for the carriage of passengers for wedding parties to change the vehicle to a 1988 or later model Ford LTD stretched limousine with seating capacity of 12 or fewer seats and to include the ability to operate for the carriage of passengers for debutante balls, birthdays, anniversaries, The Melbourne Cup, Oaks Day, Werribee Cup, Concerts, theatre trips, school formals and tourist activities.

V. Mifsud, Delahey. Application for variation of conditions of licence SV1265 which authorises the licensed vehicle to operate in respect of a Mercedes Benz stretched limousine with seating capacity for 7 passengers for wedding parties to change the vehicle with seating capacity of 12 or fewer seats and to include the ability to operate for debutante balls, birthdays, anniversaries, The Melbourne Cup, Oaks Day, Werribee Cup, concerts, theatre tips, school formals and tourist activities.

Seymour Passenger Services Pty Ltd, Seymour. Application for variation of conditions of licence CC193 which authorises the licensed vehicle to operate as a country special service omnibus from within a 20km pick-up radius of the Seymour Post Office to include the ability to operate a service for the carriage of children attending Goulburn Valley Grammar School and Notre Dame College to the exclusion of all other passengers excepting duly authorised teachers.

D. J. Wright, Glen Waverley. Application for variation of conditions of licence SV1416 which authorises the licensed vehicle to operate in respect of a 1978-80 model, air-conditioned 280SEL Mercedes Benz sedan with seating capacity for 4 passengers to change the vehicle to a 1959 Rolls Royce sedan with seating capacity for 4 passengers.

Dated 4 March 1999.

ROBERT STONEHAM  
Manager - Operations  
Victorian Taxi Directorate

---

### **Associations Incorporation Act 1981**

#### Sub-Section 36(2)

Notice is hereby given that the incorporation of the associations mentioned below will be cancelled on publication of the notice.

A.C. Milan Club Melbourne Inc.  
 Alberton Junior Football Association Inc.  
 Altona Women's Group Inc.  
 Apex Club of Vermont Inc.  
 Association of Victorian Model Railway Clubs Inc.  
 Australian Crohns and Colitis Association Inc.  
 Ballarat Association for Gifted and Talented Children Inc.  
 Bass Valley Wonthaggi & District Football League Trainers Association Inc.  
 Bayplay Kindy Inc.  
 Benalla Employment Skills Training Inc.  
 Bhartiya Mandir Society Inc.  
 Bread Manufacturers Association of Victoria Inc.  
 Briagolong Badminton Club Inc.  
 Broadmeadows Financial Counselling Service Inc.  
 Camberwell/Hawthorn Planning Watch Inc.  
 Central Highlands Regional Housing Council Inc.  
 Church and Charitable Private Hospitals Association Inc.  
 Cobram Corroboree Committee Inc.  
 College Crescent Community Group Inc.  
 Crest Club of Shepparton Inc.  
 Croydon Spiritual Church Inc.  
 "Diversity Links" Inc.  
 Doncaster/Caulfield Community Bus Service Inc.  
 Echuca Combined Welfare Services Inc.  
 Emerald Hills & Cardinia Palliative Care Service Inc.  
 Essendon Community Group Inc.  
 Friends of Sages Cottage Inc.  
 Friends of the Elsternwick Classic Cinema Inc.  
 Gisborne Maternal and Child Health Support Group Inc.  
 Good Shepherd Hostels Inc.  
 Gymkids Inc.  
 Inner North Business Council Inc.  
 International Christian Family Fellowship Inc.

Islamic Human Rights League Inc.  
 Ivanhoe Movie and Video Club Inc.  
 Mainstreet Morwell Inc.  
 Melbourne Rising Sports Club Inc.  
 Metro Tourers Inc.  
 Molyullah Woolshed Inc.  
 Nachtmusique Chamber Ensemble Inc.  
 Organic Growers & Sustainable Living Network Inc.  
 Quota International of Newcomb Inc.  
 Southern Peninsula Art Group Inc.  
 St Albans Ski Club Inc.  
 Talbot Ratepayers and Residents Association Inc.  
 The Cowes T.O.W.N. Club of Victoria Inc.  
 The Fellowship of Friends Inc.  
 The Gatehouse Day Centre Association Inc.  
 The Leslie Mabel Foundation Inc.  
 The Pristine Ponds Group Inc.  
 The Satisfactionist Society of Australia Inc.  
 The Thoona & District Echo Community Newspaper Inc.  
 The Yearinga Tennis Club Inc.  
 Victorian Community Information Network Inc.  
 Victorian Music Makers Association Inc.  
 Victorian Rural Divisions Co-ordinating Unit Inc.  
 Watsonia Netball Club Inc.  
 Wedderburn Old Time Dance Club Inc.  
 Wimmera Dive Club Inc.  
 Wimera Employment Promotions Inc.  
 World Education Fellowship-Victorian Section Inc.  
 Wycheproof Craft Group Inc.  
 Young Adults Arthritis Group Inc.

Dated 30 November 1998.

BERNADETTE STEELE  
 Registrar of Incorporated Associations

---

**Planning and Environment Act 1987**  
 ALL PLANNING SCHEMES IN VICTORIA  
 Notice of Approval of Amendment  
 Amendment S81

The Minister for Planning and Local Government has approved Amendment S81 to all Planning Scheme.

The Amendment comes into operation on the date this notice is published in the Government Gazette.

- The Amendment introduces the State gaming controls to the Market Towers Shopping complex at Lot 1 on PS 407843, 303-313 Hampshire Road, Sunshine. The installation of gaming machines will be prohibited.

A copy of the Amendment can be inspected, free of charge, during office hours, at the Department of Infrastructure, Customer Service Centre, Upper Plaza, Nauru House, 80 Collins Street, Melbourne.

LEIGH PHILLIPS  
 Director, Planning Operations  
 Planning, Heritage  
 and Market Information  
 Department of Infrastructure

---

**Planning and Environment Act 1987**  
 BAW BAW PLANNING SCHEME  
 Notice of Approval of Amendment  
 Amendment C4

The Minister for Planning and Local Government has approved Amendment C4 to the Baw Baw Planning Scheme.

The Amendment comes into operation on the date this notice is published in the Government Gazette.

The Amendment facilitates the Nilma interchange and includes: rezoning Part of Crown Allotment 16A, Parish of Darnum from Urban Floodway Zone to Township Zone, correcting a Heritage Overlay map reference number, exempting roadworks and associated vegetation impacts from planning approval under Schedule One to the Environmental Significance Overlay, and exempting the need for a planning permit to remove, destroy or lop native vegetation within the works area.

A copy of the Amendment can be inspected, free of charge, during office hours, at the Department of Infrastructure, Customer Service Centre, Upper Plaza, Nauru House, 80 Collins Street, Melbourne and at the offices of the Baw Baw Shire Council, Civic Place, Warragul.

LEIGH PHILLIPS  
 Director, Planning Operations  
 Planning, Heritage  
 and Market Information  
 Department of Infrastructure

---



**Planning and Environment Act 1987**  
HUME PLANNING SCHEME  
Notice of Approval of Amendment  
Amendment L47

The Minister for Planning and Local Government has approved Amendment L47 to the Hume Planning Scheme.

The Amendment comes into operation on the date this notice is published in the Government Gazette.

The Amendment inserts a provision within the General Farming B zone which will allow a permit to be sought for a petrol station, convenience shop, take away food premises and cafe on land at 475 Sunbury Road, Bulla.

A copy of the Amendment can be inspected, free of charge, during office hours, at the Department of Infrastructure, Customer Service Centre, Upper Plaza, Nauru House, 80 Collins Street, Melbourne and at the offices of the Hume City Council, Macedon Street, Sunbury.

LEIGH PHILLIPS  
Director, Planning Operations  
Planning, Heritage  
and Market Information  
Department of Infrastructure

**Planning and Environment Act 1987**  
MAFFRA PLANNING SCHEME  
Notice of Approval of Amendment  
Amendment L34

The Minister for Planning and Local Government has approved Amendment L34 to the Maffra Planning Scheme.

The Amendment comes into operation on the date this notice is published in the Government Gazette.

The Amendment

- Rezones Part Crown Allotments 6 and 7, Section 9, Parish of Briagolong, Avon Street, Briagolong from Residential to Public Use Zone - Victoria Police.

A copy of the Amendment can be inspected, free of charge, during office hours, at the Department of Infrastructure, Customer Service Centre, Upper Plaza, Nauru House, 80 Collins

Street, Melbourne and at the offices of the Wellington Shire Council, Civic Centre, Sale.

LEIGH PHILLIPS  
Director, Planning Operations  
Planning, Heritage  
and Market Information  
Department of Infrastructure

**Planning and Environment Act 1987**  
**Planning and Environment (Planning Schemes) Act 1996**

MELBOURNE PLANNING SCHEME  
Notice of Approval of Planning Scheme

The Minister for Planning and Local Government has approved the new Melbourne Planning Scheme.

The planning scheme comes into operation on the date this notice is published in the Government Gazette.

The planning scheme affects all of the area of the municipal district of the Melbourne City Council with the exception of the area covered by the Port of Melbourne Planning Scheme.

The new Melbourne Planning Scheme, as required by the **Planning and Environment (Planning Schemes) Act 1996**, includes selected State standard provisions from the Victoria Planning Provisions, including the state policy framework, various zones and overlays, particular provisions relating to use and development, administrative provisions and definitions. The new planning scheme also includes a municipal strategic statement, local policies and schedules to some of the zones, overlays and other provisions. The new scheme also incorporates a number of documents specified in the planning scheme, and contains new maps applying the standardised zones and overlays to land within the area covered by the scheme.

Any planning scheme or any part of a planning scheme in force immediately before the commencement of the new Melbourne Planning Scheme is revoked to the extent that it applies to the area covered by the new Melbourne Planning Scheme. Any amendment to a planning scheme or any part of a planning scheme which is revoked lapses.

A copy of the new planning scheme can be inspected, free of charge, during office hours at:

Department of Infrastructure, Customer Service Centre, Upper Plaza, Nauru House, 80 Collins Street, Melbourne 3000, Melbourne City Council, 6th Floor, Council House, 200 Little Collins Street, Melbourne 3000.

LEIGH PHILLIPS  
Director, Planning Operations  
Planning, Heritage  
and Market Information  
Department of Infrastructure

---

**Planning and Environment Act 1987  
Planning and Environment (Planning  
Schemes) Act 1996**

**QUEENSCLIFFE PLANNING SCHEME**  
Notice of Approval of planning scheme

The Minister for Planning and Local Government has approved the new Queenscliffe Planning Scheme.

The planning scheme comes into operation on the date this notice is published in the Government Gazette.

The planning scheme affects all of the area of the municipal district of the Queenscliffe Borough Council and an area 600 metres seaward of the low water mark into Port Phillip Bay and Swan Bay.

The new Queenscliffe Planning Scheme, as required by the **Planning and Environment (Planning Schemes) Act 1996**, includes selected State standard provisions from the Victoria Planning Provisions, including the state policy framework, various zones and overlays, particular provisions relating to use and development, administrative provisions and definitions. The new planning scheme also includes a municipal strategic statement, local policies and schedules to some of the zones, overlays and other provisions. The new scheme also incorporates a number of documents specified in the planning scheme, and contains new maps applying the standardised zones and overlays to land within the area covered by the scheme.

Any planning scheme or any part of a planning scheme in force immediately before the commencement of the new Queenscliffe Planning Scheme is revoked to the extent that it applies to the area covered by the new Queenscliffe Planning Scheme. Any amendment to a planning scheme or any part of a planning scheme which is revoked lapses.

A copy of the new planning scheme can be inspected, free of charge, during office hours, at: Department of Infrastructure, Customer Service Centre, Upper Plaza, Nauru House, 80 Collins Street, Melbourne; Department of Infrastructure, South Western Region, 63 McKillop Street, Geelong 3220 and Queenscliffe Borough Council, Municipal Offices, 50 Learmonth Street, Queenscliffe 3225 .

LEIGH PHILLIPS  
Director, Planning Operations  
Planning, Heritage  
and Market Information  
Department of Infrastructure

---

**Planning and Environment Act 1987  
Planning and Environment (Planning  
Schemes) Act 1996**

**WYNDHAM PLANNING SCHEME**  
Notice of Approval of planning scheme

The Minister for Planning and Local Government has approved the new Wyndham Planning Scheme.

The planning scheme comes into operation on the date this notice is published in the Government Gazette.

The planning scheme affects all of the area of the municipal district of the Wyndham City Council together with an area of the Werribee Marina which is identified as all that area of land that forms part of Port Phillip Bay beyond low and high water mark from a point on the crown foreshore reserve measuring approximately 200 metres north east from Lot 1, LP222211, No. 25 Duncan's Road, Werribee South, south east 500 metres into Port Phillip Bay, then south west 500 metres, then west 400 metres to the shore line and then 70 metres to Duncan's Road.

The new Wyndham Planning Scheme, as required by the **Planning and Environment (Planning Schemes) Act 1996**, includes selected State standard provisions from the Victoria Planning Provisions, a municipal strategic statement, state and local policy frameworks, standardized zones, overlays, particular provisions relating to use and development, and a number of administrative provisions and definitions. The new planning scheme also incorporates a number of documents specified in the planning scheme, and contains new maps applying the standardised zones and overlays to land within the area covered by the scheme.

Any planning scheme in force immediately before the commencement of the new Wyndham Planning Scheme is revoked and any amendment to that scheme lapses.

A copy of the new planning scheme can be inspected, free of charge, during office hours, at the Department of Infrastructure, Customer Service Centre, Upper Plaza, Nauru House, 80 Collins Street, Melbourne 3000 and at Wyndham City Council, Princes Highway, Werribee.

LEIGH PHILLIPS  
Director, Planning Operations  
Planning, Heritage  
and Market Information  
Department of Infrastructure

---

**ORDERS IN COUNCIL**

**Melbourne City Link Act 1995**

DIVESTING OF LAND

The Governor in Council, on the recommendation of the Minister for Planning and Local Government (being the Minister administering the **Melbourne City Link Act 1995**) and the Minister for Roads and Ports (being the Minister administering the provisions of the **Transport Act 1983** under which the roads Corporation is established), under section 31(1)(b) of the **Melbourne City Link Act 1995** divests from the Roads Corporation the area of 101m<sup>2</sup> shown diagonally hatched on the plan numbered LEGL/99-8 lodged in the Central Plan Office.

Dated 2 March 1999.

Responsible Minister:  
ROBERT MACLELLAN  
Minister for Planning and Local Government  
STACEY ROBERTSON  
Acting Clerk of the Executive Council

**Land Act 1958**

APPROVAL BY THE GOVERNOR IN  
COUNCIL TO THE SALE OF CROWN  
LAND BY PRIVATE TREATY

Order in Council

The Governor in Council, pursuant to section 99A(1)(a) & 99A(2) of the **Land Act 1958**, approves the sale by private treaty of the Crown land described below.

**Property Address:** Golf Course Road, Dimboola.

**Crown Description:** Allotment 61 and 78 Section B, Parish of Dimboola.

Dated 2 March 1999.

Responsible Minister:  
ROGER M. HALLAM MLC  
Minister for Finance  
STACEY ROBERTSON  
Acting Clerk of the Executive Council

**Land Act 1958**

APPROVAL BY THE GOVERNOR IN  
COUNCIL TO THE SALE OF CROWN  
LAND BY PRIVATE TREATY

Order in Council

The Governor in Council, pursuant to section 99A(1)(a) & 99A(2) of the **Land Act**

**1958**, approves the sale by private treaty of the Crown land described below.

**Property Address:** Fasham & Westh Streets, Underbool.

**Crown Description:** Allotment 27A Section 5 Township of Underbool.

Dated 2 March 1999.

Responsible Minister:  
ROGER M. HALLAM MLC  
Minister for Finance

STACEY ROBERTSON  
Acting Clerk of the Executive Council

**Land Act 1958**

APPROVAL BY THE GOVERNOR IN  
COUNCIL TO THE SALE OF CROWN  
LAND BY PRIVATE TREATY

Order in Council

The Governor in Council, pursuant to section 99A(1)(a) & 99A(2) of the **Land Act 1958**, approves the sale by private treaty of the Crown land described below.

**Property Address:** Railway Avenue, Bright.

**Crown Description:** Allotment 5B Section B2 Township of Bright.

Dated 2 March 1999.

Responsible Minister:  
ROGER M. HALLAM MLC  
Minister for Finance

STACEY ROBERTSON  
Acting Clerk of the Executive Council

**Land Act 1958**

SALE OF CROWN LAND  
BY PRIVATE TREATY

Order in Council

The Governor in Council, pursuant to section 99A(1)(a) & 99A(2) of the **Land Act 1958**, approves the sale by private treaty of Crown Allotments 16A & 16B, Section 67E, Parish of Melbourne South, located at 69-119 Salmon Street, Port Melbourne.

Dated 2 March 1999.

Responsible Minister:  
ROGER M. HALLAM MLC  
Minister for Finance

STACEY ROBERTSON  
Acting Clerk of the Executive Council

**Crown Land (Reserves) Act 1978**

NOTICE OF INTENTION

The Governor in Council under Section 10 of the **Crown Land (Reserves) Act 1978** gives notice of intention to revoke the following temporary reservations:

**ARARAT** — The temporary reservation by Order in Council of 4 March, 1997 of an area of 47 square metres of land being Crown Allotment 21G, Section E, Township of Ararat, Parish of Ararat as a site for Public and Municipal Purposes. — (Rs 418).

**BENDIGO** — The temporary reservation by Order in Council of 15 May, 1973 of an area of 1796 square metres of land in Section K, At Bendigo, Parish of Sandhurst as a site for Public purposes (Children's Playground), and the temporary reservation for additional purpose of Public Recreation by Order in Council of 14 October, 1986. — (Rs 9742).

This Order is effective from the date on which it is published in the Victoria Government Gazette.

Dated 2 March 1999

Responsible Minister:  
MARIE TEHAN  
Minister for Conservation  
and Land Management

STACEY ROBERTSON  
Acting Clerk of the Executive Council

**Crown Land (Reserves) Act 1978**

NOTICE OF INTENTION

The Governor in Council under Section 10 of the **Crown Land (Reserves) Act 1978** gives notice of intention to revoke the following temporary reservations to the extent indicated hereunder:

**GATUM GATUM** — The temporary reservation by Order in Council of 1 September, 1970 of an area of 6070 square metres of land in the Parish of Gatum Gatum as a site for Public Purposes (Trigonometrical Survey Station), revoked as to part by Orders in Council of 4 September, 1984 and 11 August, 1992, so far only as the portion containing 486 square metres as indicated by hatching on plan hereunder. — (G148[3]) — (Rs 9308).

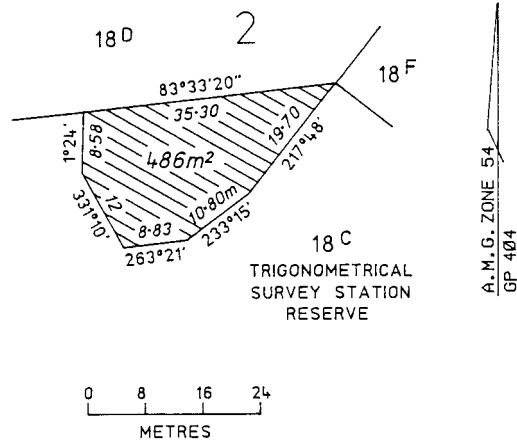

**MARYBOROUGH** — The whole of the temporary reservation by Order in Council of 10 March, 1913 of an area of 12.917 hectares of land in Section 7B, Parish of Maryborough (formerly in the Township of Bowenvale) as a site for Water Supply purposes. — (Rs 6563).

This Order is effective from the date on which it is published in the Victoria Government Gazette.

Dated 2 March 1999

Responsible Minister:  
MARIE TEHAN  
Minister for Conservation  
and Land Management

STACEY ROBERTSON  
Acting Clerk of the Executive Council

**Crown Land (Reserves) Act 1978**

NOTICE OF INTENTION

The Governor in Council under Section 10 of the **Crown Land (Reserves) Act 1978** gives notice of intention to revoke the following temporary reservation:

**PHILLIP ISLAND** — The temporary reservation under Section 5 of the **Crown Land (Reserves) Act 1978** of 27.47 hectares of land being part of Crown Allotment 120, Parish of Phillip Island transferred to the Crown by transfer No. R234894L registered in the Office of Titles on 26 February, 1991, for the propagation and management of wildlife. — (Rs 14331).

This Order is effective from the date on which it is published in the Victoria Government Gazette.

Dated 2 March 1999

Responsible Minister:  
MARIE TEHAN  
Minister for Conservation  
and Land Management

STACEY ROBERTSON  
Acting Clerk of the Executive Council

**Crown Land (Reserves) Act 1978**  
REVOCATION OF TEMPORARY  
RESERVATIONS

The Governor in Council under Section 10 of the **Crown Land (Reserves) Act 1978** revokes the following temporary reservations to the extent indicated hereunder:

MARYVALE — The whole of the temporary reservation by Order in Council of 25 May, 1976 of an area of 2024 square metres of land being Crown Allotment 69R, Parish of Maryvale as a site for Public Purposes (Public Offices). — (Rs 10149).

NEERIM — The whole of the temporary reservation by Order in Council of 30 October, 1923 of an area of 683 square metres of land in the Township of Neerim, (formerly Village of Neerim), Parish of Neerim as a site for a State School. — (Rs 2845).

NEERIM — The whole of the temporary reservation by Order in Council of 18 February, 1969 of an area of 127 square metres, more or less, of land in the Township of Neerim, Parish of Neerim as a site for State School purposes — (Rs 2845).

OAKLEIGH — The temporary reservation by Order in Council of 21 October, 1940 of an area of 17.81 hectares, more or less, of land in the Township of Oakleigh, Parish of Mulgrave as a site for Public Park and Recreation, revoked as to part by various Orders, so far only as the portion containing 313 square metres shown as Crown Allotment 45L, Township of Oakleigh, Parish of Mulgrave on Certified Plan No. 119165 lodged in the Central Plan Office. — (Rs 1121).

This Order is effective from the date on which it is published in the Victoria Government Gazette.

Dated 2 March 1999

Responsible Minister:  
MARIE TEHAN  
Minister for Conservation  
and Land Management

STACEY ROBERTSON  
Acting Clerk of the Executive Council

**Crown Land (Reserves) Act 1978**  
REVOCATION OF TEMPORARY  
RESERVATION

The Governor in Council under Section 10 of the **Crown Land (Reserves) Act 1978** revokes the following temporary reservation to the extent indicated hereunder:

DOOLAM — The temporary reservation by Order in Council of 29 July, 1969 of an area of 3238 square metres of land in the Parish of Doolam as a site for Public Purposes (Trigonometrical Survey Station), so far only as the portion containing 29.7 square metres as indicated by hatching on plan published in the Victoria Government Gazette on 21 January 1999 - page 125. — (Rs 9184).

This Order is effective from the date on which it is published in the Victoria Government Gazette.

Dated 2 March 1999

Responsible Minister:  
MARIE TEHAN  
Minister for Conservation  
and Land Management

STACEY ROBERTSON  
Acting Clerk of the Executive Council

**Crown Land (Reserves) Act 1978**  
CROWN LANDS TEMPORARILY  
RESERVED

The Governor in Council under Section 4(1) of the **Crown Land (Reserves) Act 1978** temporarily reserves the following Crown lands for the purposes mentioned:-

MUNICIPAL DISTRICT OF THE  
CASEY CITY COUNCIL

EUMEMMERRING — Preservation of an area of ecological significance, 11.04 hectares, being Crown Allotment 43A, Parish of Eumemmerring shown as Reserve No. 1 on Plan of Subdivision No. 402680J lodged in the Office of Titles. — (Rs 37199).

MUNICIPAL DISTRICT OF THE  
MOYNE SHIRE COUNCIL

PURA PURA — Public Recreation, 1.065 hectares, more or less, being Crown Allotment 15, Section 1, Township of Pura Pura, Parish of Kornong as indicated by hatching on plan hereunder. — (P180[3]) — (0303821).

This Order is effective from the date on which it is published in the Victoria Government Gazette.

Dated 2 March 1999

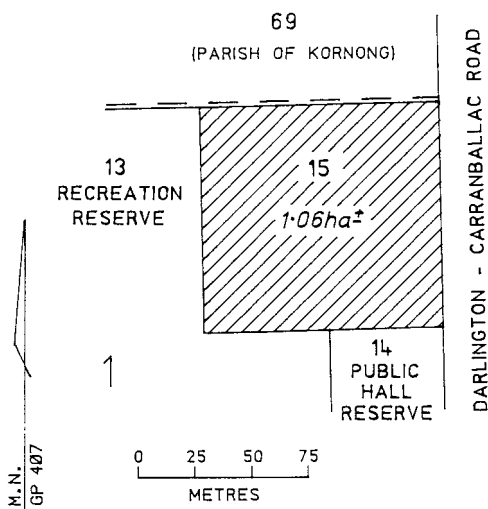

Responsible Minister:  
MARIE TEHAN  
Minister for Conservation  
and Land Management

STACEY ROBERTSON  
Acting Clerk of the Executive Council

by deletion of the words "(Lighthouse purposes)" therefrom. — Rs 9950.

This Order is effective from the date on which it is published in the Victoria Government Gazette.

Dated 2 March 1999

Responsible Minister:  
MARIE TEHAN  
Minister for Conservation  
and Land Management

STACEY ROBERTSON  
Acting Clerk of the Executive Council

**Land Act 1958**

**UNUSED ROADS CLOSED**

The Governor in Council under Section 349 of the **Land Act 1958** and with the consent in writing of the municipalities concerned closes the following unused roads:

MUNICIPAL DISTRICT OF THE  
GOLDEN PLAINS SHIRE COUNCIL

SMYTHESDALE — The road in the Township of Smythesdale, Parish of Smythesdale shown as Crown Allotment 6E, Section 43 on Certified Plan No. 117204 lodged in the Central Plan Office. — (93-1138).

MUNICIPAL DISTRICT OF THE  
MORNINGTON PENINSULA SHIRE COUNCIL

WANNAEUE — The road in the Parish of Wannaeue as indicated by hatching on plan hereunder. — (W32[3]) — (Rs 9950).

**Crown Land (Reserves) Act 1978**

**INTERPRETATION OF  
LEGISLATION ACT 1984**

**Amendment of Temporary Reservation**

The Governor in Council under Section 4(1) of the **Crown Land (Reserves) Act 1978** and Section 27 of the **Interpretation of Legislation Act 1984** amends the Order in Council made on 21 August, 1974 and published in the Victoria Government Gazette on 28 August, 1974 page 3159 of the temporary reservation of an area of 1820 square metres, more or less, of land in the Parish of Wannaeue, County of Mornington as a site for Public Purposes (Lighthouse purposes)

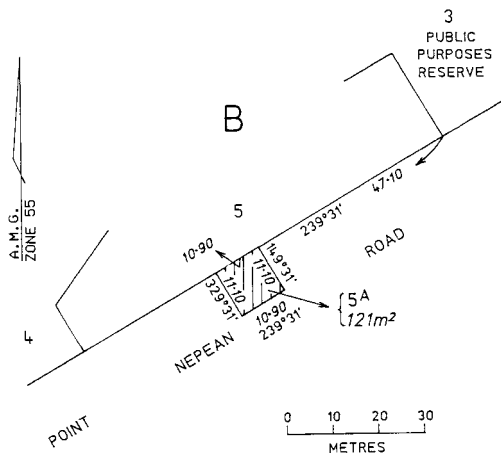

This Order is effective from the date on which it is published in the Victoria Government Gazette.

Dated 2 March 1999

Responsible Minister:  
MARIE TEHAN  
Minister for Conservation  
and Land Management

STACEY ROBERTSON  
Acting Clerk of the Executive Council

---

### Land Act 1958

#### UNUSED ROAD CLOSED

The Governor in Council under Section 349 of the **Land Act 1958** and with the consents in writing of the municipality concerned and the adjoining owners closes the following unused road:

#### MUNICIPAL DISTRICT OF THE MURRINDINDI SHIRE COUNCIL

BUXTON — The road in the Parish of Buxton shown as Crown Allotments 7D and 7E on Certified Plan No. 119241 lodged in the Central Plan Office. — (L7-3104).

This Order is effective from the date on which it is published in the Victoria Government Gazette.

Dated 2 March 1999

Responsible Minister:  
MARIE TEHAN  
Minister for Conservation  
and Land Management

STACEY ROBERTSON  
Acting Clerk of the Executive Council

---

### Crown Land (Reserves) Act 1978

#### INCORPORATION OF COMMITTEE OF MANAGEMENT OF THE TREASURY RESERVE

The Governor in Council under Section 14A(1) of the **Crown Land (Reserves) Act 1978**, being satisfied that it is in the public interest to declare to be a corporation the Committee of Management appointed under Section 14(2) of the Act of the land described in the schedule hereunder:-

(a) declares that the Committee of Management shall be a corporation;

(b) assigns the name "THE TREASURY RESERVE INCORPORATED" to the corporation; and

under Section 14B(3) of the Act, appoints John RICKARD to be Chairperson of the corporation.

#### SCHEDULE

1. Crown Allotment 3, Section 5, City of Melbourne, Parish of Melbourne North temporarily reserved as a site for Public Purposes (Public Buildings) by Order in Council of 2 February, 1999 (published in the Victoria Government Gazette on 4 February, 1999 - page 210; and
2. the remaining land in Section 5, City of Melbourne, Parish of Melbourne North temporarily reserved as a site for Reserve for Public Offices and Approaches thereto by Order in Council of 11 August, 1936.

Rs 4588.

This Order is effective from the date on which it is published in the Victoria Government Gazette.

Dated 2 March 1999

Responsible Minister:  
MARIE TEHAN  
Minister for Conservation  
and Land Management

STACEY ROBERTSON  
Acting Clerk of the Executive Council

---

### Crown Land (Reserves) Act 1978

#### ASSIGNMENT OF NEW NAME TO AN INCORPORATED COMMITTEE OF MANAGEMENT

The Governor in Council under Section 14A(5) of the **Crown Land (Reserves) Act 1978** assigns the new name "Berringa Historic School and Cricket Reserve Committee of Management Incorporated" to the corporation constituted as the "Berringa Historic School Reserve Committee of Management Incorporated" under Section 14A(1) of the **Crown Land (Reserves) Act 1978** by Order in Council of 17 September, 1996 and published in the Victoria Government Gazette on 19 September, 1996 - page 2484-5. — Rs 8141.

This Order is effective from the date on



which it is published in the Victoria Government Gazette.

Dated 2 March 1999

Responsible Minister:  
MARIE TEHAN  
Minister for Conservation  
and Land Management

STACEY ROBERTSON  
Acting Clerk of the Executive Council

---

LATE NOTICES

Crown Land (Reserves) Act 1978

ORDER GIVING APPROVAL TO THE GRANT OF LEASES

Under sections 17D and 17DA of the Crown Land (Reserves) Act 1978, I, Marie Tehan, Minister for Conservation and Land Management, being satisfied that there are special reasons which make granting a lease reasonable and appropriate in the particular circumstances and to do this will not be substantially detrimental to the use and enjoyment of any adjacent land reserved under the Crown Land (Reserves) Act 1978, approve the granting of a lease to the Elsternwick Park Bowls Club for the playing of bowls, associated social activities and hire of the hall for community purposes on part of Elsternwick Park described in the Schedule below in accordance with section 17D(3)(a) of the Crown Land (Reserves) Act 1978, state that:

- c) there are special reasons which make granting the leases reasonable and appropriate in the particular circumstances; and
d) to do this will not be substantially detrimental to the use and enjoyment of any adjacent land reserved under the Crown Land (Reserves) Act 1978.

SCHEDULE

The land shown on the attached plan as Elsternwick Park Bowling Club, being part of the land permanently reserved for Public Park and Recreation by various Orders in Council and gazettals as set out below:

Table with 2 columns: Orders in Council and Government Gazettes. It lists dates and gazette references for the Elsternwick Park Bowling Club land.

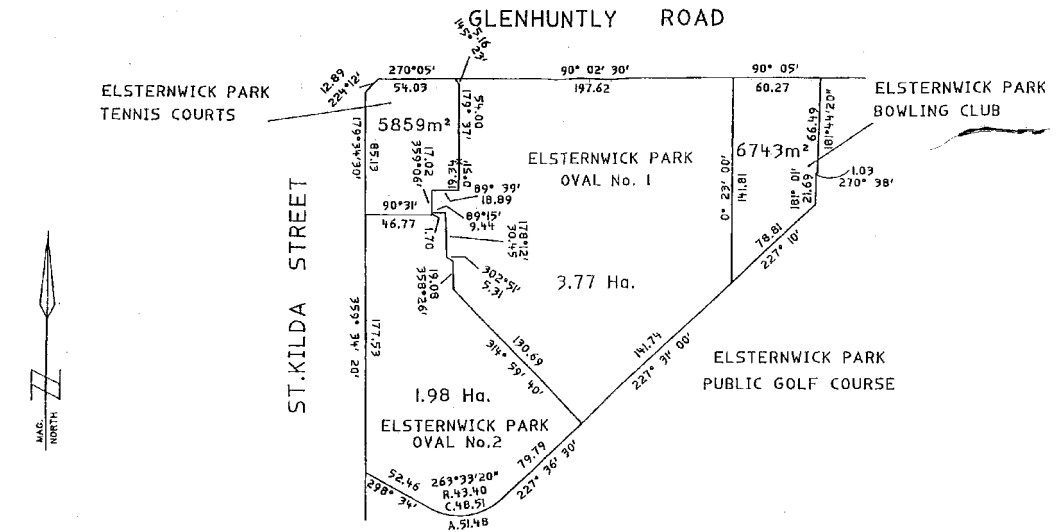

Table with 3 columns: NOTATIONS, SURVEYORS REF., ORIGINAL SHEET SIZE. It contains technical details about the survey and the original drawing.

Dated 22 February 1999

MARIE TEHAN MP
Minister for Conservation
and Land Management

**Crown Land (Reserves) Act 1978**

**ORDER GIVING APPROVAL TO THE GRANT OF LEASES**

Under sections 17D and 17DA of the **Crown Land (Reserves) Act 1978**, I, Marie Tehan, Minister for Conservation and Land Management, being satisfied that there are special reasons which make granting a lease reasonable and appropriate in the particular circumstances and to do this will not be substantially detrimental to the use and enjoyment of any adjacent land reserved under the **Crown Land (Reserves) Act 1978**, approve the granting of a lease to the Victorian Amateur Football Association for the playing of football and other social activities normally conducted by a football club on part of Elsternwick Park described in the Schedule below in accordance with section 17D(3)(a) of the **Crown Land (Reserves) Act 1978**, state that:

- a) there are special reasons which make granting the leases reasonable and appropriate in the particular circumstances; and
- b) to do this will not be substantially detrimental to the use and enjoyment of any adjacent land reserved under the **Crown Land (Reserves) Act 1978**.

**SCHEDULE**

The land shown on the attached plan as Elsternwick Park Oval No. 1, being part of the land permanently reserved for Public Park and Recreation by various Orders in Council and gazettals as set out below:

<u>Orders in Council</u>	<u>Government Gazettes</u>
12 November 1872	20 December 1872, page 1623
9 October 1876	13 October 1876, page 1887
22 September 1880	24 September 1880, page 2396

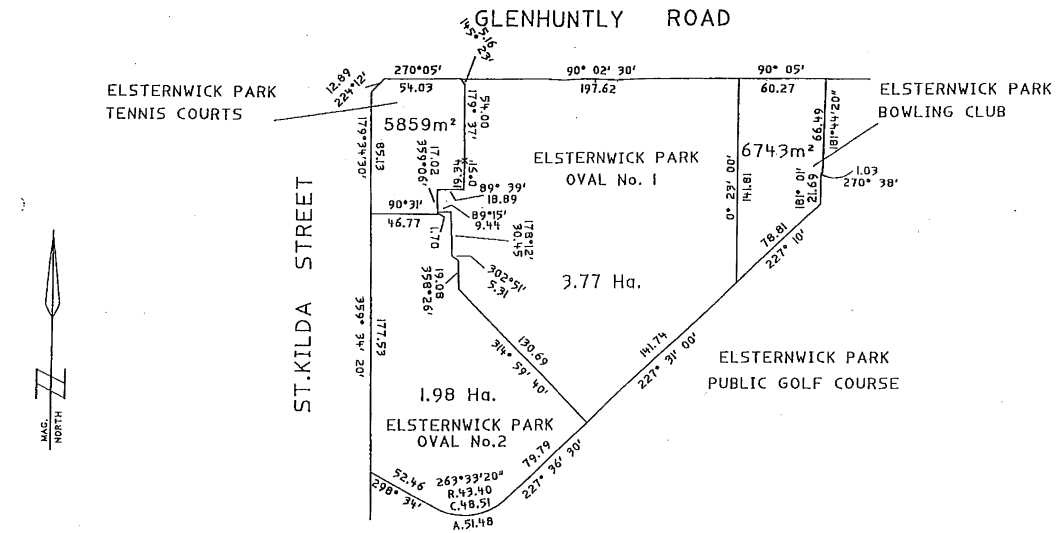

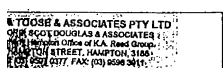
<p>NOTATIONS</p> <p>  <b>TJOSE &amp; ASSOCIATES PTY LTD</b>                  40 COLLEGE STREET, MELBOURNE VIC 3000                  PH (03) 9638 3111 FAX (03) 9638 3111             </p> <p>                 SURVEYORS REF. <b>H4374</b>                  ORIGINAL SHEET NO. <b>2000</b>                  SCALE <b>A3</b> </p>	<p>PLAN FOR LEASE PURPOSES</p> <p>ELSTERNWICK PARK</p> <p>ELSTERNWICK</p>
--	---

Dated 22 February 1999

**MARIE TEHAN MP**  
 Minister for Conservation  
 and Land Management

**Crown Land (Reserves) Act 1978**

**ORDER GIVING APPROVAL TO THE GRANT OF LEASE**

Under sections 17D and 17DA of the **Crown Land (Reserves) Act 1978**, I, Marie Tehan, Minister for Conservation and Land Management, being satisfied that there are special reasons which make granting a lease reasonable and appropriate in the particular circumstances and to do this will not be substantially detrimental to the use and enjoyment of any adjacent land reserved under the **Crown Land (Reserves) Act 1978**, approve the granting of a lease for the purpose of camping and caravan park by the Bass Coast Shire Council as Committee of Management to Garry Rex Beaton and Marlene Denise Beaton over part of the Cape Paterson Foreshore Reserve described in the Schedule below in accordance with section 17D(3)(a) of the **Crown Land (Reserves) Act 1978**, state that:

- a) there are special reasons which make granting the leases reasonable and appropriate in the particular circumstances; and
- b) to do this will not be substantially detrimental to the use and enjoyment of any adjacent land reserved under the **Crown Land (Reserves) Act 1978**.

**SCHEDULE**

The land shown hatched and cross hatched on the attached plan, being part of the land declared permanently reserved for the Protection of the Coastline by Order in Council dated 8 September 1981 and notification in the Government Gazette of 16 September 1981, page 3027.

**APPENDIX A**

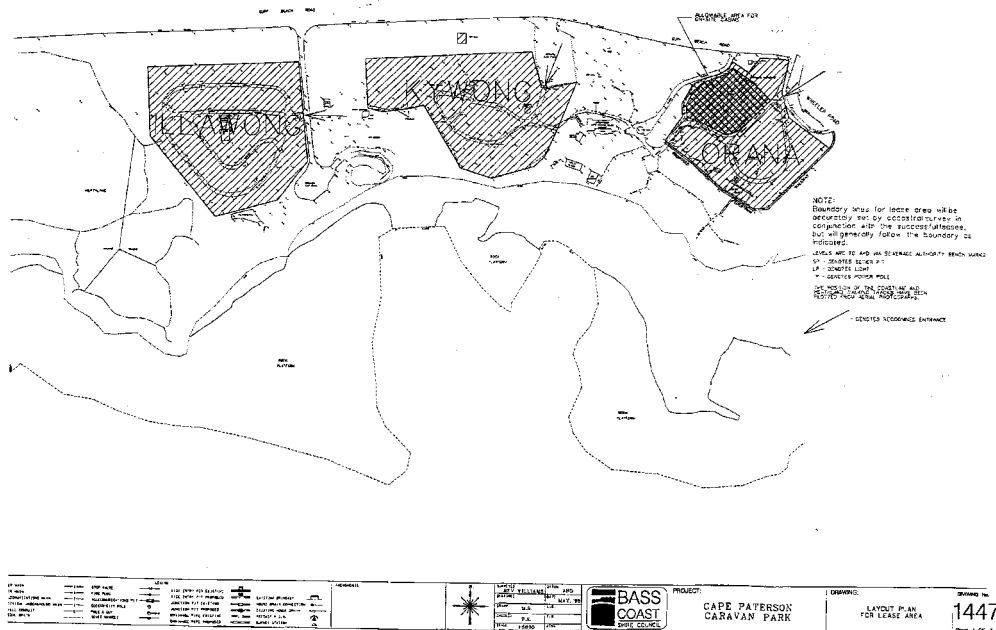

Dated 22 February 1999

MARIE TEHAN MP  
Minister for Conservation  
and Land Management



**SUBORDINATE LEGISLATION ACT 1994  
NOTICE OF MAKING OF STATUTORY  
RULES**

Notice is hereby given under Section 17 (2) of the **Subordinate Legislation Act 1994** of the making of the following Statutory Rules:

21. *Statutory Rule:* Health (Exempt Businesses) (Amendment) Regulations 1999  
*Authorising Act:* Health Act 1958  
*Date of making:* 2 March 1999
22. *Statutory Rule:* Melbourne City Link (Prescribed Administrative Costs) Regulations 1999  
*Authorising Act:* Melbourne City Link Act 1995  
*Date of making:* 2 March 1999

**SUBORDINATE LEGISLATION ACT 1994  
NOTICE THAT STATUTORY RULES ARE  
OBTAINABLE**

Notice is hereby given under Section 17 (3) of the **Subordinate Legislation Act 1994** that the following Statutory Rules were first obtainable from Information Victoria, 356 Collins Street, Melbourne on the date specified:

14. *Statutory Rule:* Rules of the Council of Legal Education (Amendment No. 1) 1999  
*Authorising Act:* Legal Practice Act 1996  
*Date first obtainable:* 25 February 1999  
*Code A*
15. *Statutory Rule:* Club Keno (Amendment) Regulations 1999  
*Authorising Acts:* Club Keno Act 1993  
Tattersall Consultations Act 1958  
*Date first obtainable:* 4 March 1999  
*Code A*
16. *Statutory Rule:* Plumbing (Amendment) Regulations 1999  
*Authorising Act:* Building Act 1993  
*Date first obtainable:* 4 March 1999  
*Code A*
17. *Statutory Rule:* Road Safety (Driving Instructors) Regulations 1999  
*Authorising Act:* Road Safety Act 1986  
*Date first obtainable:* 4 March 1999  
*Code A*
18. *Statutory Rule:* Liquor Control Reform (Prescribed Substance) Regulations 1999  
*Authorising Act:* Liquor Control Reform Act 1998  
*Date first obtainable:* 4 March 1999  
*Code A*

19. *Statutory Rule:* Gas Industry (MSO Rules) Regulations 1999  
*Authorising Act:* Gas Industry Act 1994  
*Date first obtainable:* 4 March 1999  
*Code A*

Retail price will vary according to the number of pages in each special or periodical gazette. The table below sets out the prices that apply

<i>Price Code</i>	<i>No. of Pages (Including cover and blank pages)</i>	<i>Price</i>
A	1-16	\$2.90
B	17-32	\$4.30
C	33-48	\$5.90
D	49-96	\$9.15
E	97-144	\$11.85
F	145-192	\$14.00
G	193-240	\$16.15
H	241-288	\$17.20
I	289-352	\$19.35
J	353-416	\$22.60
K	417-480	\$25.80
L	481-544	\$30.10
M	545-608	\$34.40
N	609-672	\$38.70
O	673-736	\$43.00
P	737-800	\$47.30

#### ADVERTISERS PLEASE NOTE

As from 4 March 1999

The last Special Gazette was No. 31 dated 3 March 1999

The last Periodical Gazette was No. 1 dated 2 June 1998

## CONTENTS

	Page
Estates of Deceased Persons	529
Government and Outer Budget Sector	
Agencies Notices	537
Orders in Council—	560
Acts — Melbourne City Link; Land; Crown Land (Reserves)	
Private Advertisements	528
Proclamations	536

The Victoria Government Gazette is published by The Craftsman Press Pty. Ltd. with the authority of the Government Printer for the State of Victoria  
© State of Victoria 1999

ISSN 0819-5471

This publication is copyright. No parts may be reproduced by any process except in accordance with the provisions of the Copyright Act.

Products and services advertised in this publication are not endorsed by The Craftsman Press Pty. Ltd. or the State of Victoria and neither of them accepts any responsibility for the content or the quality of reproduction. The Craftsman Press Pty. Ltd. reserves the right to reject any advertising material it considers unsuitable for government publication.

Address all inquiries to the Government Printer for the State of Victoria  
1 Macarthur Street  
Melbourne 3002 Victoria Australia

### RETAIL SALES

Information Victoria Bookshop  
356 Collins Street Melbourne 3000.  
Telephone enquiries 1300 366 356

City Graphics  
2nd Floor, 4 Bank Place  
Melbourne 3000  
Telephone enquiries (03) 9600 0977

**Recommended Retail Price \$1.70**

*Government and Outer Budget Sector Agencies please note:*  
**STYLE REQUIREMENTS.**

To ensure that material received can be reproduced, and that errors are minimised, the following guidelines are to be observed when submitting material by fax.

**Fax resolution:**

Material sent by fax should be transmitted using Fine Resolution (200 dots per inch by 200 dpi).

**Font size:**

Use 12 point (10 pitch) or larger.

**Font Style:**

Clear plain font styles, such as Helvetica, should be used.

**Graphics:**

Line drawings should be transmitted as large as possible to ensure clarity. Drawings up to A4 size sent by fax using Fine Resolution provide a good quality for reproduction.

**Avoid:**

Italics, underlining and full justification.

Ensure document is square when sending as documents that are sent skewed are difficult to read and process.