



Victoria Government Gazette

No. G 13 Thursday 1 April 1999

GENERAL

GENERAL AND PERIODICAL GAZETTE

Copy to: Gazette Officer
The Craftsman Press Pty. Ltd.
125 Highbury Road,
Burwood Vic 3125
Telephone: (03) 9926 1233
Facsimile: (03) 9926 1292
DX: 32510 Burwood
Email: gazette@craftpress.com.au

Advertising Rates and Payment

Private Notices

Payment must be received in advance with advertisement details.

30 cents per word - Full page \$180.00.

Additional costs must be included in prepayment if a copy of the gazette is required. Copy Prices - Page \$1.50 - Gazette \$3.20 Certified copy of Gazette \$3.50. (all prices include Postage). **Cheques should be made payable to The Craftsman Press Pty. Ltd.**

Government and Outer Budget Sector Agencies Notices

Not required to pre-pay.

Advertisements may be faxed or sent via email with a cover sheet, marked to the attention of the Gazette Officer. Floppy Disks (Mac & PC) can also be accepted.

Costs can be calculated on the following basis:

Per Line	Typeset
Single column	\$1.55
Double column	\$3.10
Full Page	\$64.80

The Craftsman Press is pleased to offer a series of discounts from the typesetting costs.

1. Copy supplied on disk.
2. Copy supplied via email.
3. Artwork for forms and other material which require exact reproduction.

1. Copy supplied on disk.

Where a disk is supplied and there is minimum alteration required, **30% off.**

Where a disk is supplied requiring extraneous matter stripped out and styles applied, **20% off.**

2. Copy supplied via email.

Where a notice is sent via email and there is minimum alteration required, **25% off.**

Where email is supplied requiring extraneous matter stripped out and styles applied, **15% off.**

3. Artwork for forms and other material which requires exact reproduction.

Scanning and sizing of artwork for forms, to be reproduced in page format, **35% off.**

Copy Deadline for General Gazette

9.30 a.m. Monday - (Private Notices)

9.30 a.m. Tuesday - (Government and Outer Budget Sector Agencies Notices)

Advertisers should note:

- Late copy received at The Craftsman Press Pty. Ltd. after deadlines will be placed in the following issue of VGG, irrespective of any date/s mentioned in the copy (unless otherwise advised).
- Proofs will be supplied only when requested or at the direction of the Gazette Officer.
- No additions or amendments to material for publications will be accepted by telephone.
- Orders in Council may be lodged prior to receiving assent with the Governor's or Clerk's signature. They will only be published once approved and signed.
- Government and Outer Budget Sector Agencies please note: *See style requirements on back page.*

SPECIAL GAZETTES

Copy to: Gazette Officer
The Craftsman Press Pty. Ltd.
125 Highbury Road,
Burwood Vic 3125
Telephone: (03) 9926 1233
Facsimile: (03) 9926 1292
Email: gazette@craftpress.com.au

Advertising Rates and Payment

Private Notices

Full Page \$360.00

Payment must be received in advance with notice details.

Government and Outer Budget Sector Agencies Notices

	Typeset
Full Page	\$87.50

Note:

The after hours number for Special Gazettes is:

Telephone: 0419 327 321

SUBSCRIPTIONS AND RETAIL SALES

Copies of the Victoria Government Gazette can be purchased from The Craftsman Press Pty. Ltd. by subscription.

The Victoria Government Gazette

General and Special - \$170.00 each year

General, Special and Periodical - \$227.00 each year

Periodical - \$113.00 each year

Subscriptions are payable in advance and accepted for a period of one year. All subscriptions are on a firm basis and refunds will not be given.

All payments should be made payable to The Craftsman Press Pty. Ltd.

Subscription enquiries:

The Craftsman Press Pty. Ltd.
125 Highbury Road, Burwood Vic 3125
Telephone: (03) 9926 1233

INDEX TO PRIVATE ADVERTISERS

A

A.B. Natoli Pty756
Aitken Walker & Strachan756

C

Chessell Williams756

D

De Marco & Co.756
Dunhill Madden Butler757

E

Equity Trustees Limited757

G

Garden & Green757
Gray Friend & Long757

H

Harwood Andrews757
Hassell & Byrne758
Heinz & Partners758
Home Wilkinson & Lowry758

J

John Burgess & Co.758
John Keating & Associates758

L

Lyttletons758

M

Mackay Taylor758
Maddock Lonie & Chisholm759
Mills Oakley759
M. J. Wignall, Equity Trustees Ltd759

N

National Mutual Trustees Limited759

P

Purves Clarke Richards760

S

S. C. McCarthy & Co. Pty760
Still & Co.760

T

Tolhurst Druce & Emmerson760

V

Verhoeven & Curtain760
Verna A. Cook760

W

White Cleland Pty760

**PUBLICATION OF THE
VICTORIA GOVERNMENT
GAZETTE (GENERAL)
EASTER PUBLIC HOLIDAYS**

PLEASE NOTE:

The Victoria Government Gazette for the Easter week will be published on Thursday 8 April 1999. All copy for private advertisements must reach the Government Gazette Office by 9.30 a.m. on Thursday 1 April 1999. Copy for advertisements for the Government and Outer Budget Sector Agencies section must reach the Government Gazette Office by 9.30 a.m. on Tuesday 6 April 1999.

Where urgent gazettal is required after hours, arrangements should be made with Ann White on 0419 327 321.

ANN WHITE
Government Gazette Officer

PRIVATE ADVERTISEMENTS

HOMICIDE

\$100,000 Reward

The co-operation of the general public is sought with a view to establishing the identity of the person or persons responsible for the death of Mersina Halvagas at the Fawkner Cemetery on 1 November, 1997.

A reward of up to One Hundred Thousand Dollars (\$100,000) will be paid at the discretion of the Chief Commissioner of Police, by the Government of Victoria, for information leading to the arrest and subsequent conviction of the person or persons responsible for this offence.

Any information will be treated as strictly confidential and may be given at any time to Crime Stoppers via telephone number, Toll Free 1800 333 000, or the Homicide Squad, 412 St Kilda Road, Melbourne on (03) 9865 2770 during normal business hours.

M. N. COMRIE
Chief Commissioner of Police

DISSOLUTION OF PARTNERSHIP

Notice is hereby given that the partnership heretofore subsisting between Geoffrey Arthur Matthews, Ross Cameron Matthews and Christopher John Hatt all of the Bull & Mouth Hotel, Horsham, carrying on business as hotelkeepers at the Bull & Mouth Hotel at Horsham under the style or firm of G. A. & R. C. Matthews & C. J. Hatt, has been dissolved by mutual consent as from 10 December 1998 so far as concerns the said Ross Cameron Matthews and Christopher John Hatt who retired from the said firm. All debts due to and owing by the said firm will be received and paid respectively by Geoffrey Arthur Matthews who will continue to carry on the said business under the style or firm of Bull & Mouth Hotel, Horsham.

Dated 26 March 1999.

BYRNE, JONES & TORNEY, solicitors,
38 Lydiard Street South, Ballarat, Vic, 3350.

WILLIAM JAMES ROBINSON, late of 188 Station Street, Fairfield, Victoria. Creditors, next-of-kin and others having claims in respect of the estate of the abovenamed deceased, who died on 31 January 1999, are required by

Carmel Alice Robinson of 188 Station Street, Fairfield, Victoria, Records Officer, the executrix of the deceased's will, to send particulars of their claim to the said executrix, care of the undermentioned solicitors by 1 June 1999 after which date they will convey or distribute the assets having regard only to the claims of which they then have notice.

A. B. NATOLI PTY, solicitors,
24 Cotham Road, Kew 3101.

PETER GEORGE DENNIS, late of Moliagul, retired, deceased. Creditors, next-of-kin and others having claims in respect of the estate of the deceased, who died on 2 January 1999, are required by the personal representative, Paul Charles Dennis of 91 Middlesex Road, Surrey Hills, to send particulars to him care of the undermentioned solicitors by 9 June 1999 after which date the personal representative may convey or distribute the assets having regard only to the claims of which he then has notice.

AITKEN WALKER & STRACHAN,
solicitors,
114 William Street, Melbourne 3000.

Creditors, next-of-kin and others having claims against the estate of SUSAN KATHLEEN JARDINE, late of Lynn Private Nursing Home, 11 Elgin Avenue, Armadale, Victoria, gentlewoman, deceased, who died on 12 October 1998 are requested to send particulars of their claims to Equity Trustees Limited of 472 Bourke Street, Melbourne, Victoria, the executor appointed by the will, by 10 June 1999 after which date it will distribute the assets having regard only to the claims at which date it then has notice.

CHESSELL WILLIAMS, solicitors,
379 Collins Street, Melbourne 3000.

MITRA LIACH, late of 38 Arndt Road, Pascoe Vale, Victoria, widow, deceased. Creditors, next-of-kin and others having claims in respect of the estate of the deceased, who died on 13 November 1998 are required by the trustee, Dobrila Tuskan of 51 Arndt Road, Pascoe Vale, Victoria, home duties, daughter, to send particulars to the trustee by 26 May 1999 after which date the trustee may convey or

distribute the assets having regard only to the claims of which the trustee has notice.

DE MARCO & CO., solicitors,
209 Glenroy Road, Glenroy 3046.

Creditors, next-of-kin or others having claims in respect of the estate of RONALD JAMES BROOKS, deceased, who died on 7 November 1996, are to send particulars of their claims to the executors, Violet Letitia Brooks, Lawrence John Brooks, Maureen Wells and Francine Kidd, care of 1A Resthaven Road, South Hurstville, New South Wales, by 10 June 1999 after which date the executors will distribute the assets having regard only to the claims of which the executors then have notice.

DUNHILL MADDEN BUTLER, solicitors,
575 Bourke Street, Melbourne.

Creditors, next-of-kin or others having claims in respect of the estate of GABRIELLE ESTELLE MUNDAY, deceased, who died on 3 February 1999 are to send particulars of their claims to the executor, Cheryl Jean Munday of 41 Elliott Avenue, Balwyn, Victoria, by 10 June 1999 after which date the executor will distribute the assets having regard only to the claims of which the executor then has notice.

DUNHILL MADDEN BUTLER, solicitors,
575 Bourke Street, Melbourne.

GEORGE KEITH SPICER, late of "Leeward", Lot 15, Purves Road, Main Ridge. Creditors, next-of-kin and others having claims in respect of the estate of the deceased, who died on 2 August 1998 are required by the trustee, Equity Trustees Limited of 472 Bourke Street, Melbourne, to send particulars to them by 8 June 1999 after which date the trustee may convey or distribute the assets having regard to the claims of which they then have notice.

KATHLEEN PAYNTER, late of Paynter Road, Chillingollah via Swan Hill, Victoria, farmer, deceased. Creditors, next-of-kin and others having claims in respect of the estate of the deceased, who died on 28 November 1997 are required by the trustees, Edwin Thomas Paynter and Maree Ann Byrne, to send particulars to them care of the undermentioned solicitors by 26 May 1999 after which date the trustees may convey or distribute the assets

having regard only to the claims of which they then have notice.

GARDEN & GREEN, lawyers,
4 McCallum Street, Swan Hill.

ERNEST CHARLES ROGERS, late of 76 Stradbroke Avenue, Swan Hill, Victoria, retired storeman, deceased. Creditors, next-of-kin and others having claims in respect of the estate of the deceased, who died on 2 November 1998 are required by the trustee, Evelyn Alice Rogers, to send particulars to her care of the undermentioned solicitors by 26 May 1999 after which date the trustee may convey or distribute the assets having regard only to the claims of which she then has notice.

GARDEN & GREEN, lawyers,
4 McCallum Street, Swan Hill.

HAROLD WRIGLEY, late of Northhaven Aged Home, Shadforth Street, Kerang, Victoria, retired, deceased. Creditors, next-of-kin and others having claims in respect of the estate of the deceased, who died on 15 January 1999, are required by the trustee, David George Wrigley, to send particulars to him care of the undermentioned solicitors by 26 May 1999, after which date the trustee may convey or distribute the assets, having regard only to the claims of which he then has notice.

GARDEN & GREEN, lawyers,
4 McCallum Street, Swan Hill.

RITA BARR, formerly of Neerim but late of Lyrebird Village Hostel, Neerim Street, Drouin, widow, deceased. Creditors, next-of-kin and others having claims in respect of the estate of the deceased, who died on 21 December 1998 are required by the trustees, Eric Leigh Barr and Phillip George Barr, to send particulars of their claims to them care of the undersigned solicitors by 5 June 1999 after which date the trustees may convey or distribute the assets having regard only to the claims of which they then have notice.

GRAY FRIEND & LONG, solicitors,
70 Queen Street, Warragul 3820.

GEORGE ZAMMIT, late of 18 Walscott Street, Geelong West, labourer, deceased. Creditors, next-of-kin and others having claims in respect of the estate of the deceased, who died

on 13-16 August 1997 are required by the personal representative of the deceased's estate, to send particulars to him care of the undermentioned lawyers by 4 June 1999 after which date the personal representative may convey or distribute the assets having regard only to the claims of which he then has notice.

HARWOOD ANDREWS, lawyers,
10 Station Street, Werribee 3030.

Creditors, next-of-kin and others having claims against the estate of FLORENCE AMELIA HITCHINS, late of 26 Luntar Road, South Oakleigh, Victoria, who died on 4 February 1999, are required by the executor, Kevin John Hitchins of 10 Enmore Court, Chelsea Heights, to send detailed particulars of their claims to the said executor, c/- Hassall & Byrne, solicitors of 308 Highett Road, Highett 3190, by 1 June 1999 after which date he will proceed to distribute the assets having regard only to the claims of which he then has notice.

HASSALL & BYRNE, solicitors,
308 Highett Road, Highett 3190.

Creditors, next-of-kin and others having claims in respect of the estate of JOSEPH JAMES ROBINSON, late of 100 Vickers Street, Sebastopol, Victoria, retired concrete tester, deceased, who died on 20 June 1998 are to send particulars of their claims to the executor, care of the undermentioned solicitors by 3 June 1999 after which date the executor will distribute the assets, having regard only to the claims of which the executor then has notice.

HEINZ & PARTNERS, solicitors,
6 Dawson Street North, Ballarat.

Creditors, next-of-kin and others having claims in respect of the estate of LEOKADIA KOZUCH, also known as Leokdia Kozuch, late of 2 Rothschild Street, Glen Huntly, in the State of Victoria, who died on 7 July 1998 are required by the personal representatives of the deceased, Barry Berger and Glenn Robert Hodges, solicitors, to send particulars of them c/- of the undermentioned solicitors by 10 June 1999 after which date they will distribute the assets having regard only to the claims of which they then have notice.

HOME WILKINSON & LOWRY, solicitors,
Level 44, Nauru House, 80 Collins Street,
Melbourne 3000.

MATYLDA CERVENKA, deceased. Creditors, next-of-kin and others having claims in the estate of the abovenamed, late 14 Michael Street, Springvale, widow, deceased, who died on 9 January 1999, are required by the executors, Peter Sfyris and Voula Sfyris, both of 10 Knell Street, Mulgrave, to send particulars thereof care of the undersigned prior to 3 June 1999 after which date the executors will distribute the assets of the estate having regard only to those claims of which the then have notice.

JOHN BURGESS & CO.,
solicitors for the executors,
257 Springvale Road, Springvale.

Creditors, next-of-kin or others having claims in respect of the estate of FRANCES MYRTLE ROBINSON, also known as Frances Evelyn Robinson, late of Darva Lodge, 185 Bentons Road, Mornington, Victoria, spinster, deceased, who died on 15 March 1999, are to send particulars of their claims to the executor, care of the undermentioned solicitors by 31 May 1999 after which date the executor will distribute the assets having regard only to the claims of which the executor then has notice.

JOHN KEATING & ASSOCIATES, solicitors,
191 Greville Street, Prahran 3181.

ARTHUR WILLIAM MADDICKS, also known as Arthur Williams Maddicks, late of Yarraman Psychogeriatric Nursing Home, Yarraman Road, Noble Park, Victoria, retired storeman, deceased. Creditors, next-of-kin and others having claims in respect of the estate of the deceased, who died on 14 January 1999 are required by the executrix, Joan Annette Frost, to send particulars to her care of the undermentioned solicitors by a date not later than two months from the date of publication hereof after which date the executrix may convey or distribute the assets having regard only to the claims of which she then has notice.

LYTTLETONS, solicitors,
53 Marcus Road, Dingley.

Creditors, next-of-kin or others having claims in respect of the estate of SYLVIA JEAN VERONICA BARR, late of Lyndoch, Hopkins Road, Warrnambool, who died on 7 December 1998 are to send particulars of their claims to the

executor, care of the undermentioned solicitors by 1 June 1999 after which date the executor will distribute the assets having regard only to the claims of which the executor then has notice.

MACKAY TAYLOR, solicitors,
135 Kepler Street, Warrnambool 3280.

DORIS LILLIAN GUNNYON, in the will called Doris Lilian Gunnyon, late of Nirvana Nursing Home, 78 Nirvana Avenue, East Malvern, Victoria, but formerly of "Castlebar", Castlebar Road, Oakleigh, Victoria, widow, deceased. Creditors, next-of-kin and others having claims in respect of the estate of the deceased, who died on 21 January 1999, are required by the trustee, Rodney David George Birrell of 5 Raheen Court, Vermont South, Victoria, executive officer, to send particulars to the trustee by 1 June 1999 after which date the trustee may convey or distribute the assets having regard only to the claims of which the trustee then has notice.

MADDOCK LONIE & CHISHOLM,
solicitors,
140 William Street, Melbourne.

ROBERT GLOVER MOCKRIDGE, late of 1/11 Cannes Avenue, Surfers Paradise, Queensland, but formerly of Unit 33, 8-10 The Esplanade, St Kilda, Victoria, retired company director, deceased. Creditors, next-of-kin and others having claims in respect of the estate of the deceased, who died on 30 January 1999, are required by the trustees, Robert Graham Riley Mockridge, of 1/11 Cannes Avenue, Surfers Paradise, Queensland, newsagent and Suzanne Tanya Mockridge of 113 Richmond Terrace, Richmond, Victoria, recreation planner, to send particulars to the trustees by 1 June 1999 after which date the trustees may convey or distribute the assets having regard only to the claims of which the trustees then have notice.

MADDOCK LONIE & CHISHOLM,
solicitors,
140 William Street, Melbourne.

Creditors, next-of-kin and others having claims in respect of the estate of LINDA LORRAINE HARDY, late of 77 Walara Drive, Mount Martha, Victoria, widow, deceased, who died on 12 January 1999, are required by the executor, ANZ Executors & Trustee Company

Limited of 530 Collins Street, Melbourne, Victoria, to send particulars to it by 1 June 1999 after which date it may convey or distribute the estate having regard only to the claims of which it then has notice.

MILLS OAKLEY, lawyers,
131 Queen Street, Melbourne.

LOUISA ANNIE HAWTHORN, late of Unit 117 Salford Park, 100 Harold Street, Wantirna, retired, deceased. Creditors, next-of-kin and others having claims in respect of the estate of the deceased, who died on 5 September 1998 are required by Equity Trustees Limited, the executor of the will of the deceased, to send particulars of their claims to Equity Trustees Limited by 14 June 1999 after which date it will convey or distribute the assets having regard only to the claims of which it then has notice.

M. J. WIGNELL, Equity Trustees Ltd,
472 Bourke Street, Melbourne 3000.

JAMES LAMMING, also known as Clarence Melville Lamming, late of Aberfield Private Nursing Home, 2 Carre Street, Elsternwick, pensioner. Creditors, next-of-kin and others having claims in respect of the estate of the deceased, who died on 22 December 1998 are required by National Mutual Trustees Limited of 65 Southbank Boulevard, Southbank, Victoria 3006, the applicant for a grant of probate, to send particulars to it by 2 June 1999 after which date the applicant for a grant of probate may convey or distribute the assets having regard only to the claims of which it then has notice.

WINIFRED MAVIS OLIVE SAUNDERS, late of 47 Aikman Crescent, Chadstone, married woman. Creditors, next-of-kin and others having claims in respect of the estate of the deceased, who died on 9 December 1998 are required by National Mutual Trustees Limited of 65 Southbank Boulevard, Southbank, Victoria 3006, the applicant for a grant of probate, to send particulars to it by 2 June 1999 after which date the applicant for a grant of probate may convey or distribute the assets having regard only to the claims of which it then has notice.

Creditors, next-of-kin and others having claims in respect of the estate of STEPHEN MARK SUTHERLAND, late of 34 Hakea Road, Huntly, Victoria, linesman, deceased, who died on 3 July 1998 are required to send particulars of their claims to the executors, National Mutual Trustees Limited of 46 Queen Street, Bendigo, by 11 June 1999 after which date they will distribute the assets having regard only to the claims of which they then have notice.

NATIONAL MUTUAL TRUSTEES LIMITED,
46 Queen Street, Bendigo.

Creditors, next-of-kin or others having claims in respect of the estate COLIN BRUCE TUCK, late of 71 Rubicon Street, Reservoir, Victoria, retired draughtsman, deceased, who died on 1 September 1998 are to send particulars of their claims to the executor, care of the undermentioned solicitors by 27 May 1999 after which date the executor will distribute the assets having regard only to the claims of which the executor then has notice.

PURVES CLARKE RICHARDS, solicitors,
121 William Street, Melbourne.

WALTER FRANK RATTRAY, late of 83 Preston Street, Rye, Victoria, retired administrator, deceased. Creditors, next-of-kin and others having claims in respect of the estate of the deceased, who died on 15 August 1998, are required to send particulars of their claims to the trustee, Shane Christopher McCarthy, care of the undermentioned solicitors by 23 May 1999 after which date the trustee will distribute the assets of the estate having regard only to the claims of which he then has notice.

S. C. McCARTHY & CO. PTY, solicitors,
2247 Point Nepean Road, Rye 3941.

Creditors, next-of-kin or others having claims in respect of the estate of EDWARD THOMAS CHARLES HITCHCOCK, late of 170 Ryans Road, Eltham North, Victoria, pensioner, deceased, who died on 8 November 1998 are to send particulars of their claims to the administrator, care of the undermentioned solicitors by 31 May 1999 after which date the administrator will distribute the assets having regard only to the claims of which the administrator then has notice.

STILL & CO, solicitors,
32 Sydney Road, Kilmore 3764.

Creditors, next-of-kin and others having claims against the estate of ROBERT HENRY PACKER, late of 17 Calypso Court, Forest Hill, Victoria, retired, deceased, who died on 1 January 1999, are required to send particulars of their claims to Debra Julie Packer of 2 Caroline Avenue, Cockatoo, Victoria, home duties, the executrix of the said deceased, on or before 1 June 1999 after which date she will distribute the assets having regard only to the claims of which she then has notice.

TOLHURST DRUCE & EMMERSON,
solicitors,
389 Lonsdale Street, Melbourne.

SYBIL GREGORY, late of Narracan Gardens Nursing Home, Amaroo Way, Moe, in the State of Victoria, widow, deceased. Creditors, next-of-kin and others having claims in respect of the estate of the deceased, who died on 16 December 1998 are required by the personal representatives, Robert Carmody of 7 Gardner Street, Moe and Edward Spinks of Walhalla Road, Erica, to send particulars to them care of the undermentioned solicitors by 30 June 1999 after which date the personal representatives may convey or distribute the assets having regard only to the claims of which they then have notice.

VERHOEVEN & CURTAIN, solicitors,
Suite 4, 46 Haigh Street, Moe 3825
10A Commercial Road, Morwell 3840.

Creditors, next-of-kin and others having claims against the estate of FRANCIS TREVOR MULLIN, also known as Frank Trevor Mullin, late of 1 Grove Street, Vermont, Victoria, retired, deceased, who died on 3 January 1999, are required to send particulars of their claims to the executor care of the undermentioned solicitor by 4 June 1999 after which date the executor will proceed to distribute the assets having regard only to the claims of which he shall then have had notice.

VERNA A. COOK, solicitor,
5/8 St. Andrews Street, Brighton 3186.

Creditors, next-of-kin and others having claims in respect of the estate of HAROLD BOX, late of "Warrawee", 854a Centre Road, Bentleigh East, retired printer, deceased, who died on 25 December 1998, are required to send particulars of their claims to the executors,

William McKenzie Cleland of 454 Nepean Highway, Frankston and Avis Ann Eldridge of 11 Flowerdale Road, Moorabbin on or before 1 June 1999 after which date they will distribute the assets having regard only to the claims of which they then have notice.

WHITE CLELAND PTY., solicitors,
454 Nepean Highway, Frankston.

In the Supreme Court of the State of Victoria
SALE BY THE SHERIFF

On 6 May 1999 at 2.30 p.m. at the Sheriff's Office, 8-20 King Street, Oakleigh, (unless process be stayed or satisfied).

All the estate and interest (if any) of Geoffrey Laurence Brown of 151 Koornalla Crescent, Mount Eliza, joint proprietor with Iris Ann Jeanette Brown of an estate in fee simple in the land described on Certificate of Title Volume 7861 Folio 019 upon which is erected a dwelling known as 151 Koornalla Crescent, Mount Eliza.

Registered Mortgage Nos. L53674X, P13034P and Caveat No. L374595T and the Covenant contained in Transfer 1548410 affect the said estate and interest.

Terms - Cash only.

SW-98-008822-9

Dated 1 April 1999.

S. BLOXIDGE
Sheriff's Office

In the Supreme Court of the State of Victoria
SALE BY THE SHERIFF

On 6 May 1999 at 2.30 p.m. at the Sheriff's Office, 8-20 King Street, Oakleigh, (unless process be stayed or satisfied).

All the estate and interest (if any) of Narcan Aktepe of 8 Morwell Crescent, Dallas, as shown on Certificate of Title as Nurcan Aktepe, joint proprietor with Recep Aktepe of an estate in fee simple in the land described on Certificate of Title Volume 8507 Folio 885 upon which is erected a house known as 8 Morwell Crescent, Dallas.

Registered Mortgage No. N904817M affects the said estate and interest.

Terms - Cash only.

SW-98-014899-3

Dated 1 April 1999.

S. BLOXIDGE
Sheriff's Office

In the County Court of the State of Victoria

SALE BY THE SHERIFF

On 6 May 1999 at 2.30 p.m. at the Sheriff's Office, 8-20 King Street, Oakleigh, (unless process be stayed or satisfied).

All the estate and interest (if any) of Nikolay Solodchenko of 11 Morwell Street, Dandenong, as shown on Certificate of Title as Nickolky Solodchenko, proprietor of an estate in fee simple in all that piece of land being Lots 72 and 73 on Plan of Subdivision No. 6672 and being the whole of the land described in Certificates of Title Volume 7967 Folio 086 and Volume 8634 Folio 068 upon which is erected a small shingle clad dwelling with Cyclone Boundary Fencing.

The property can be located by travelling to Crib Point. At the Shell Garage turn east into Disney Street and then north into Glossop Street, then east into Creswell Street, which is a gravel road. The property is at the end of Creswell Street and is known as Lots 72 and 73 Creswell Street, Crib Point.

The drainage easement reserved by Transfer 841256 affects part of the within land.

Terms - Cash only.

CW-98-001992-0

Dated 1 April 1999.

S. BLOXIDGE
Sheriff's Office

In the Supreme Court of the State of Victoria
SALE BY THE SHERIFF

On 6 May 1999 at 11.00 a.m. at the Sheriff's Office, 107 Baxter Street, Bendigo, (unless process be stayed or satisfied).

All the estate and interest (if any) of Ian Wittingslow of RMB 496 Ullina Road, Creswick, as shown on Certificate of Title as Ian Francis Wittingslow, proprietor of an estate in fee simple in Lot One on Plan of Subdivision No. 67672 consisting of approximately 1.505 hectares and being the land more particularly described on Certificate of Title Volume 8634 Folio 078 upon which is erected a dwelling with the usual outbuildings and improvements.

The property can be located by travelling to Ballarat. Head north along the Midland Highway to the Town of Creswick. Continue north for approximately 11 km. along the Ullina-Creswick Road to Lawrence. The

property is on the eastern side of the road and is the first house north of the Wheelers Bridge at Lawrence and is known as RBM 496 Ullina Road, Creswick.

Registered Mortgage No. U486384U and Caveat No. U476220W affect the said estate and interest.

Terms - Cash only.

SW-98-009794-7

Dated 1 April 1999.

S. BLOXIDGE
Sheriff's Office

TRAVEL COMPENSATION FUND

Service of Notices

Trust Deed Cl. 26

A notice to the Board of the Travel Compensation Fund is duly given if it is:

- (a) delivered or sent by prepaid post to the Fund's postal address at 4th Floor, 303 Pitt Street, Sydney, New South Wales 2000; or
- (b) sent by facsimile to the Fund's facsimile address at 02 - 9267 2100

A notice that is proved to have been properly addressed and posted is taken to have been delivered to the Fund on the third day after the day on which it was posted.

A notice sent to the Fund's facsimile address is taken to have been delivered on the next business day after it was sent.

Dated 19 March 1999.

CARLO C. BRATTONI
Chief Executive Officer
Travel Compensation Fund
19 March 1999

PROCLAMATIONS

**Livestock Disease Control (Amendment)
Act 1998**

(Act No. 83/1998)

PROCLAMATION OF COMMENCEMENT

I, James Gobbo, Governor of Victoria, with the advice of the Executive Council and under section 2(2) of the **Livestock Disease Control (Amendment) Act 1998** fix 1 April 1999 as the day on which sections 4, 11 and 14 of that Act come into operation.

Given under my hand and the seal of
Victoria on 30 March 1999.

(L.S.) JAMES GOBBO
Governor

By His Excellency's Command

PATRICK McNAMARA
Minister for Agriculture and Resources

Parish of Tongio-Mungie West as shown on Certified Plan No. 119269 lodged in the Central Plan Office. — (16/L9-5211).

This Proclamation is effective from the date on which it is published in the Victoria Government Gazette.

Given under my hand and the seal of
Victoria on 30 March 1999.

(L.S.) JAMES GOBBO
Governor

By His Excellency's Command

MARIE TEHAN
Minister for Conservation
and Land Management

**Land (Further Revocation of Reservations)
Act 1998**

PROCLAMATION OF COMMENCEMENT

I, James Gobbo, Governor of Victoria, acting with the advice of the Executive Council and under section 2(2) of the **Land (Further Revocation of Reservations) Act 1998**, fix 1 April 1999 as the day on which Part 3 of that Act and Schedule 4 to that Act come into operation.

Given under my hand and the seal of
Victoria on 30 March 1999.

(L.S.) JAMES GOBBO
Governor

By His Excellency's Command

MARIE TEHAN
Minister for Conservation
and Land Management

Land Act 1958

PROCLAMATION OF ROAD

I, James Gobbo, Governor of Victoria acting with the advice of the Executive Council and under Section 25(3)(c) of the **Land Act 1958**, proclaim as road the following land:

MUNICIPAL DISTRICT OF THE
EAST GIPPSLAND SHIRE COUNCIL

TONGIO-MUNGIE EAST and TONGIO-MUNGIE WEST - Crown Allotments 148D and 148E, No Section, Parish of Tongio-Mungie East and Crown Allotments 7H, 7J and 7K, Section 4,

**GOVERNMENT AND OUTER BUDGET SECTOR AGENCIES
NOTICES**

**MORELAND CITY COUNCIL
Road Discontinuance**

Under Section 206 and Schedule 10 Clause 3 of the **Local Government Act 1989** the Moreland City Council at its Ordinary meeting held on 14 December 1998, formed the opinion that the road shown hatched on the plan below is not reasonably required as a road for public use and has resolved to discontinue the road and to sell the land from the road by private treaty subject to any right, power or interest held by the Moreland City Council in the road in connection with any drains or pipes under the control of that authority in or near the road.

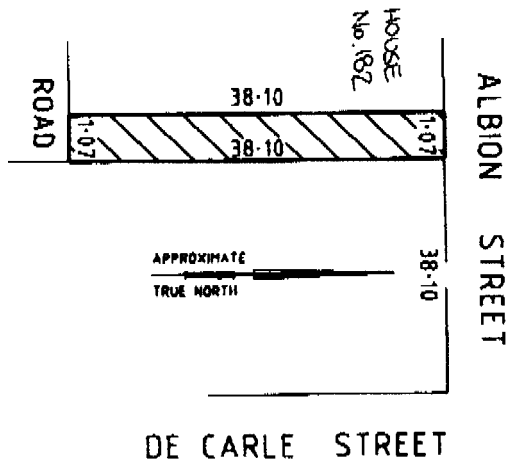

PETER JOHNSTONE
Chief Executive Officer

**LA TROBE SHIRE COUNCIL
Public Holidays Act 1993**

Erratum

Notice is hereby given that the La Trobe Shire Council pursuant to Section 7 of the **Public Holidays Act 1993** appoints Thursday 14 October 1999 as full-day Public Holiday in that part of the municipality that was the former City of Moe. The purpose of this holiday is in recognition of the Moe Cup Race meeting.

The notices gazetted in the Victorian Gazette No. G7 18 February 1999, page 443 and No. G11 18 March 1999, page 668 was incorrect and is revoked.

PENNY HOLLOWAY
Chief Executive Officer

**Planning and Environment Act 1987
GREATER GEELONG PLANNING SCHEME
Notice of Amendment
Amendment R196**

The City of Greater Geelong has prepared Amendment R196 to the Greater Geelong Planning Scheme.

The Amendment proposes to amend the Regional Section of the Greater Geelong Planning Scheme to rezone land being Barwon Water's Bell Post Hill Service Basin site, Ballarat Road, Bell Post Hill from Public Purposes No. 4 Reservation to Residential A zone.

The Amendment can be inspected at: City of Greater Geelong, 2nd Floor, 103 Corio Street, Geelong; Department of Infrastructure, Office of Planning, 63 McKillop Street, Geelong 3220 and Department of Infrastructure, Level 3 Plaza, Nauru House, 80 Collins Street, Melbourne 3000.

Submissions about the Amendment must be sent to the Planning Scheme Unit, City of Greater Geelong, P.O. Box 104, Geelong 3220 by Monday 3 May 1999.

CHUBB FADGYAS
Co-Ordinator Urban & Regional Planning



MANNINGHAM

Planning and Environment Act 1987

Notice of Amendment to the
Doncaster and Templestowe
Planning Scheme Amendment L139

Manningham City Council has prepared Amendment L139 to the Doncaster and Templestowe Planning Scheme.

The amendment affects land at 2 Mitcham Road, Doncaster and is more accurately described as CP 355182Y.

The amendment proposes to rezone the subject land from a Residential C Zone to a Mixed Use Zone. This will enable the applicant to apply for a Planning Permit to use an existing building on the land for offices. Offices are prohibited in a Residential C Zone.

A Section 173 Agreement is required and will restrict the maximum combined leasable floor area for office to 220² and will specify a maximum combined leasable floor area of 0m² for shop and trade supply.

The amendment related to the proposed office use only and will not alter the built form.

The amendment can be inspected at: Manningham City Council Municipal Offices, 899 Doncaster Road, Doncaster, Vic. 3108; Department of Infrastructure, Level 3 Plaza, Nauru House, 80 Collins Street, Melbourne, Vic. 3000.

Submissions about the amendment must be sent to: Manningham City Council, P.O. Box 1, Doncaster, Vic. 3108. Attention: Manager Economic & Environmental Planning. Before 3 May, 1999.

BOB SEIFFERT
Chief Executive

Creditors, next of kin and others having claims against the estate of any of the undermentioned deceased persons are required to send particulars of their claims to State Trustees Limited, A.C.N 064 593 148, 168 Exhibition Street, Melbourne, Victoria, 3000 the personal representative, on or before June 3, 1999 after which date State Trustees Limited may convey or distribute the assets having regard only to the claims of which State Trustees Limited then has notice.

BREWER, Daisy Gertrude, late of Unit 2, 156 Lower Dandenong Road, Mordialloc, home duties, who died on December 27, 1998.

CLARKE, Margaret Ellen, (also known as Margaret Eileen Clarke), late of Unit 162, 130 McLeod Road, Carrum, pensioner, who died January 6, 1999.

CRAWFORD, Doris Bainbridge, late of Meadowvale Retirement Village, Eagle Drive, Pakenham, pensioner, who died December 16, 1998.

DUNN, Tessa Helen (also known as Helen Lancaster & Helen Florence Grech), late of 16 Stafford Street, Abbotsford, retired, who died January 15, 1999.

FILIPOVIC, Raymond Roman, late of 44 Jopling Street, Ballan, consultant, who died January 13, 1998.

HANCOCK, George Thomas, late of Stanleigh Lodge, Hawthorn Road, North Caulfield, pensioner, who died July 30, 1998.

MARTIN, Alma May, late of Wonthaggi District Hospital, Grabham Wing, Wonthaggi, pensioner, who died December 9, 1998.

PUGSLEY, Florence Auriol Violet, late of Altona Meadows Nursing Home, 297 Queen Street, Altona Meadows, retired, who died February 6, 1999.

ZUBEK, Andrzej, late of Siepraw, Poland, retired, who died January 10, 1992.

ZUBEK, Aniela, late of Maryszyna 134, Poland, pensioner, who died February 3, 1992.

ZUBEK, Maria, late of Poznan, Poland, retired, who died March 12, 1991

Dated at Melbourne, 25 March, 1999.

CATHY VANDERFEEN
Manager, Estate Management
State Trustees Limited

VICTORIAN CIVIL AND
ADMINISTRATIVE TRIBUNAL
Anti-Discrimination List
Melbourne

Exemption No. 9 of 1999

In the matter of an Application for an Exemption under Section 83 of the **Equal Opportunity Act 1995**

Doveton North Primary School
(Applicant)

The Victorian Civil and Administrative Tribunal has considered an application pursuant to section 83 of the **Equal Opportunity Act 1995** (the Act) by Doveton North Primary School for an exemption from sections 13, 14, 100 and 195 of the Act. The application for exemption is to enable the applicant to advertise and appoint to a position of junior school services officer a person aged between 18 and 25 years.

Upon reading the material submitted in support of the application and upon hearing submissions from Mr Jeff Lovegrove for the applicant and for the reasons for decision given by the Tribunal on 25 March 1999, the Tribunal is satisfied that it is appropriate to grant an exemption from sections 13, 14, 100 and 195 of the Act to enable the applicant to advertise for

and appoint to a position of junior school services officer a person aged between 18 and 25 years.

This exemption will apply only to the respondent's school.

The Tribunal hereby grants an exemption to Doveton North Primary School from the operation of sections 13, 14, 100 and 195 of the Act subject to the above conditions to enable the applicant to advertise for and appoint to a position of junior school services officer a person aged between 18 and 25 years.

This exemption is to remain in force until 31 March 2002.

Dated this 25 March 1999.

JOHN WOLTERS
Senior Member

Department of Treasury and Finance

SALE OF CROWN LAND
BY PUBLIC AUCTION

Auction Date: 17 April 1999 at 1.30 p.m. on site.

Reference: 98/02687.

Address of Property: Corner Raglan & Perrins Street, Daylesford.

Crown Description: Crown Allotment 11B, Section 21, Parish of Wombat.

Terms of Sale: Deposit 10% - Balance 60 days.

Area: 1598 m².

Co-ordinating Officer: Garry McKenzie, McKenzie Hucker & Associates Pty Ltd, 1st Floor, City Centre Arcade, 315 Sturt Street, Ballarat, Vic. 3350.

Selling Agent: Doepel Lilley & Taylor, 41 Vincent Street, Daylesford, Vic. 3460.

ROGER M. HALLAM
Minister for Finance

Department of Treasury and Finance

SALE OF CROWN LAND
BY PUBLIC AUCTION

Auction Date: 7 May 1999 at 10.30 a.m. on site.

Reference: 98/2679.

Address of Property: Urquhart Street, Balmoral.

Crown Description: Crown Allotment 3C, Section 3, Township of Balmoral.

Terms of Sale: Deposit 10% - Balance 60 days.

Area: 3982 m².

Co-ordinating Officer: Garry McKenzie, McKenzie Hucker & Associates Pty Ltd, 1st Floor, City Centre Arcade, 315 Sturt Street, Ballarat, Vic. 3350.

Selling Agent: John F. Gorman Estate Agency, 70 Henty Street, Casterton, Vic. 331.

ROGER M. HALLAM
Minister for Finance

Department of Treasury and Finance

SALE OF CROWN LAND
BY PUBLIC AUCTION

Auction Date: 7 May 1999 at 2.30 p.m. on site.

Reference: 98/02680.

Address of Property: Whyte Street, Coleraine.

Crown Description: Crown Allotment 6B, Section 3, Township of Coleraine.

Terms of Sale: Deposit 10% - Balance 60 days.

Area: 4020 m².

Co-ordinating Officer: Garry McKenzie, McKenzie Hucker & Associates Pty Ltd, 1st Floor, City Centre Arcade, 315 Sturt Street, Ballarat, Vic. 3350.

Selling Agent: John F. Gorman Estate Agency, 70 Henty Street, Casterton, Vic. 3311.

ROGER M. HALLAM
Minister for Finance

Department of Treasury and Finance

SALE OF CROWN LAND
BY PUBLIC AUCTION

Auction Date: Thursday 29 April 1999 at 3.20 p.m. on site

Reference: 98/02681.

Address of Property: Albert Street, Ararat.

Crown Description: Crown Allotment 3D, Section 82, Township of Ararat.

Terms of Sale: Deposit 10% - Balance 60 days.

Area: 1602 m².

Co-ordinating Officer: Garry McKenzie, McKenzie Hucker & Associates Pty Ltd, 1st Floor, City Centre Arcade, 315 Sturt Street, Ballarat, Vic. 3350.

Selling Agent: Spalding McCutcheon Pty Ltd,
179 Barkly Street, Ararat, Vic. 3377.

ROGER M. HALLAM
Minister for Finance

Department of Treasury and Finance

SALE OF CROWN LAND
BY PUBLIC AUCTION

Auction Date: Thursday 29 April 1999 at 2.00
p.m. on site.

Reference: 98/02682.

Address of Property: Albert Street, Ararat.

Crown Description: Crown Allotment 8E,
Section J, Township of Ararat.

Terms of Sale: Deposit 10% - Balance 60 days.

Area: 1019 m².

Co-ordinating Officer: Garry McKenzie,
McKenzie Hucker & Associates Pty Ltd, 1st
Floor, City Centre Arcade, 315 Sturt Street,
Ballarat, Vic. 3350.

Selling Agent: Spalding McCutcheon Pty Ltd,
179 Barkly Street, Ararat, Vic. 3377.

ROGER M. HALLAM
Minister for Finance

Department of Treasury and Finance

SALE OF CROWN LAND
BY PUBLIC AUCTION

Auction Date: Thursday 29 April 1999 at 4.00
p.m. on site.

Reference: 98/02683.

Address of Property: Baird Street, Ararat.

Crown Description: Crown Allotment 6A,
Section 50, Township of Ararat.

Terms of Sale: Deposit 10% - Balance 60 days.

Area: 3410 m².

Co-ordinating Officer: Garry McKenzie,
McKenzie Hucker & Associates Pty Ltd, 1st
Floor, City Centre Arcade, 315 Sturt Street,
Ballarat, Vic. 3350.

Selling Agent: Spalding McCutcheon Pty Ltd,
179 Barkly Street, Ararat, Vic. 3377.

ROGER M. HALLAM
Minister for Finance

Department of Treasury and Finance

SALE OF CROWN LAND
BY PUBLIC AUCTION

Auction Date: Thursday 29 April 1999 at 2.40
p.m. on site.

Reference: 98/02684.

Address of Property: 27 Maude Street, Ararat.

Crown Description: Crown Allotment 17,
Section 83, Township of Ararat.

Terms of Sale: Deposit 10% - Balance 60 days.

Area: 1210 m².

Co-ordinating Officer: Garry McKenzie,
McKenzie Hucker & Associates Pty Ltd, 1st
Floor, City Centre Arcade, 315 Sturt Street,
Ballarat, Vic. 3350.

Selling Agent: Spalding McCutcheon Pty Ltd,
179 Barkly Street, Ararat, Vic. 3377.

ROGER M. HALLAM
Minister for Finance

Department of Treasury and Finance

SALE OF CROWN LAND
BY PUBLIC AUCTION

Auction Date: Thursday 29 April 1999 at 3.00
p.m. on site.

Reference: 98/02685.

Address of Property: 86 Rundell Street, Ararat.

Crown Description: Crown Allotment 16,
Section 83, Township of Ararat.

Terms of Sale: Deposit 10% - Balance 60 days.

Area: 1549 m².

Co-ordinating Officer: Garry McKenzie,
McKenzie Hucker & Associates Pty Ltd, 1st
Floor, City Centre Arcade, 315 Sturt Street,
Ballarat, Vic. 3350.

Selling Agent: Spalding McCutcheon Pty Ltd,
179 Barkly Street, Ararat, Vic. 3377.

ROGER M. HALLAM
Minister for Finance

Department of Treasury and Finance

SALE OF CROWN LAND
BY PUBLIC AUCTION

Auction Date: Thursday 29 April 1999 at 3.40
p.m. on site.

Reference: 98/02686.

Address of Property: Campbell Street, Ararat.

Crown Description: Crown Allotment 13A,
Section 49, Township of Ararat.

Terms of Sale: Deposit 10% - Balance 60 days.

Area: 1771 m².

Co-ordinating Officer: Garry McKenzie,
McKenzie Hucker & Associates Pty Ltd, 1st
Floor, City Centre Arcade, 315 Sturt Street,
Ballarat, Vic. 3350.

Selling Agent: Spalding McCutcheon Pty Ltd,
179 Barkly Street, Ararat, Vic. 3377.

ROGER M. HALLAM
Minister for Finance

Department of Treasury and Finance

SALE OF CROWN LAND
BY PUBLIC AUCTION

Auction Date: Thursday 29 April 1999 at 2.20
p.m. on site.

Reference: 98/02952.

Address of Property: Elizabeth Street, Ararat.

Crown Description: Crown Allotment 31A,
Section 78, Township of Ararat.

Terms of Sale: Deposit 10% - Balance 60 days.

Area: 1232 m².

Co-ordinating Officer: Garry McKenzie,
McKenzie Hucker & Associates Pty Ltd, 1st
Floor, City Centre Arcade, 315 Sturt Street,
Ballarat, Vic. 3350.

Selling Agent: Spalding McCutcheon Pty Ltd,
179 Barkly Street, Ararat, Vic. 3377.

ROGER M. HALLAM
Minister for Finance

Department of Treasury and Finance

SALE OF CROWN LAND
BY PUBLIC TENDER

Tenders close Friday 30 April 1999 at 2.00
p.m. at the office of McKenzie Hucker &
Associates, 315 Sturt Street, Ballarat

Reference: 98/02951.

Address of Property: Govt Road, Ellerslie.

Crown Description: Crown Allotment 3,
Section 9, Township of Ellerslie.

Terms of Sale: Deposit 10% upon acceptance -
Balance 60 days.

Area: 1.619 ha.

Co-ordinating Officer: Garry McKenzie,
McKenzie Hucker & Associates Pty Ltd, 1st
Floor, City Centre Arcade, 315 Sturt Street,
Ballarat, Vic. 3350.

ROGER M. HALLAM
Minister for Finance

FORM 7 S.21
Reg.16

NOTICE OF ACQUISITION

Compulsory Acquisition of Interest in Land

Melbourne City Link Authority declares that
by this notice it acquires the following interest
in the land described as Part of the land
contained in Certificate of Title Volume 5787
Folio 337 shown hatched on Plan Numbered
WLG/LA 5230B.

Interest Acquired: That of City of Moreland
and all other interests.

Area Acquired: 60 square metres

Published with the authority of Melbourne
City Link Authority.

The plan referred to in this notice may be
viewed at the office of Property Services
Department, VicRoads, 60 Denmark Street,
Kew.

Dated: 29 March 1999.

For and on behalf of Melbourne City Link
Authority:

T. H. HOLDEN
Manager Property Services Department

FORM 7 S.21
Reg.16

NOTICE OF ACQUISITION

Compulsory Acquisition of Interest in Land

Melbourne City Link Authority declares that
by this notice it acquires the following interest
in the land described as Part of the land
contained in Certificate of Title Volume 8092
Folio 675 shown hatched on Plan Numbered
WLG/LA 5234B.

Interest Acquired: That of City of Moreland
and all other interests.

Area Acquired: 106 square metres

Published with the authority of Melbourne
City Link Authority.

The plan referred to in this notice may be
viewed at the office of Property Services
Department, VicRoads, 60 Denmark Street,
Kew.

Dated: 29 March 1999.

For and on behalf of Melbourne City Link
Authority:

T. H. HOLDEN
Manager Property Services Department

FORM 7 S.21
Reg.16

NOTICE OF ACQUISITION

Compulsory Acquisition of Interest in Land

Melbourne City Link Authority declares that by this notice it acquires the following interest in the land described as Part of the land contained in Certificates of Title Volume 4399 Folio 665 and Volume 3683 Folio 572 shown hatched on Plan Numbered WLG/LA 5233B.

Interest Acquired: That of City of Moreland and all other interests.

Area Acquired: 476 square metres

Published with the authority of Melbourne City Link Authority.

The plan referred to in this notice may be viewed at the office of Property Services Department, VicRoads, 60 Denmark Street, Kew.

Dated: 29 March 1999.

For and on behalf of Melbourne City Link Authority:

T. H. HOLDEN
Manager Property Services Department

FORM 7 S.21
Reg.16

NOTICE OF ACQUISITION

Compulsory Acquisition of Interest in Land

Melbourne City Link Authority declares that by this notice it acquires the following interest in the land described as Part of the land contained in Certificate of Title Volume 7266 Folio 137 shown hatched on Plan Numbered WLG/LA 5228.

Interest Acquired: That of City of Moonee Valley and all other interests.

Area Acquired: 2342 square metres

Published with the authority of Melbourne City Link Authority.

The plan referred to in this notice may be viewed at the office of Property Services Department, VicRoads, 60 Denmark Street, Kew.

Dated: 29 March 1999.

For and on behalf of Melbourne City Link Authority:

T. H. HOLDEN
Manager Property Services Department

FORM 7 S.21
Reg.16

NOTICE OF ACQUISITION

Compulsory Acquisition of Interest in Land

Melbourne City Link Authority declares that by this notice it acquires the following interest in the land described as Part of the land contained in Certificate of Title Volume 7266 Folio 137 shown hatched on Plan Numbered WLG/LA 5237.

Interest Acquired: That of City of Moonee Valley and all other interests.

Area Acquired: 4 square metres

Published with the authority of Melbourne City Link Authority.

The plan referred to in this notice may be viewed at the office of Property Services Department, VicRoads, 60 Denmark Street, Kew.

Dated: 29 March 1999.

For and on behalf of Melbourne City Link Authority:

T. H. HOLDEN
Manager Property Services Department

FORM 7 S.21
Reg.16

NOTICE OF ACQUISITION

Compulsory Acquisition of Interest in Land

Melbourne City Link Authority declares that by this notice it acquires the following interest in the land described as Part of the land contained in Certificate of Title Volume 10365 Folio 691 shown hatched on Plan Numbered WLG/LA 5228B.

Interest Acquired: That of City of Melbourne and all other interests.

Area Acquired: 1890 square metres

Published with the authority of Melbourne City Link Authority.

The plan referred to in this notice may be viewed at the office of Property Services Department, VicRoads, 60 Denmark Street, Kew.

Dated: 29 March 1999.

For and on behalf of Melbourne City Link Authority:

T. H. HOLDEN
Manager Property Services Department

Tertiary Education Act 1993

GUIDELINES ISSUED BY THE MINISTER FOR TERTIARY EDUCATION AND TRAINING (PURSUANT TO SECTION 10 (4) OF THE TERTIARY EDUCATION ACT 1993) TO BE USED FOR CONSIDERING APPLICATIONS BY INSTITUTIONS FOR APPROVAL TO OPERATE AS A UNIVERSITY

1. INTRODUCTION

Guidelines have been developed to assist institutions applying under Section 10 of the **Tertiary Education Act 1993** for approval to operate as a university. The guidelines relate both to the provisions of the Act and to government policies and priorities and are published pursuant to Section 10 (4) of the Act.

1.1 *Institutions Established in Other Countries -*

Where an institution established as a university in another jurisdiction seeks approval to operate in Victoria, consideration will be given to the standing of the institution in relation to relevant accreditation processes in the other country, and in addition, to the academic standards and levels of resources to be provided within Victoria. Where such an institution seeks to work in cooperation with a Victorian institution through franchising or agency arrangements, the operating entity within Victoria must meet the criteria prescribed in Section 10 (3) of the Act and these statutory guidelines.

1.2 *Professional Bodies -*

Where an institution proposes to offer programs leading to accreditation by professional bodies, the views of the relevant bodies on all or part of the application may be sought.

1.3 *New Institutions -*

(a) It is recognised that where a new institution is proposed it will not be possible to demonstrate achievement of relevant performance standards at the time of initial review. However, the level of resources available, the experience of those involved and plans for development must be such that there is a high probability of the criteria and performance indicators being met within a specified time frame.

(b) In such cases the development will be closely monitored and progress towards achievement assessed on a regular basis. The Minister may establish conditions when granting approval, may make approval conditional upon receiving progress reports on the new institution which, in the Minister's opinion, are satisfactory, may require sponsorship by an existing university and may establish other conditions or procedures.

1.4 *Criteria and Indicators of Capacity and Performance -*

(a) In considering applications, the Minister, Department and review panels will have regard to statements about the nature of universities and criteria and indicators of performance such as those published by the Australian Vice-Chancellors Committee (AVCC) in 1989 and 1996, to comparative indicators of university performance published by the Commonwealth Department of Education, Employment and Youth Affairs, and to policy statements on universities by the Victorian Government.

(b) While size criteria as specified by the AVCC have been excluded by the policies of the Victorian Government, the size of an institution may have relevance to levels of financial and academic resources, capacity to undertake research, and educational viability.

2. CRITERIA AND PERFORMANCE INDICATORS

The following criteria and performance indicators will form the basis of consideration of any submissions made under Section 10 of the Tertiary Education Act 1993 for approval of an institution to operate as a university:

2.1 Criteria

(a) The standard of any courses of study to be offered by the University

Undergraduate and postgraduate awards must be equivalent in standard to those offered at the same level by a recognised university (A "Recognised University" for the purposes of the **Tertiary Education Act 1993** is an institution that is established or recognised as a University under an Act of an Australian Parliament)

Forms of evidence might include:

- confirmation that credit has been or will be granted by a recognised university for studies undertaken in the proposed university;
- commitment of the institution and staff to the advancement and dissemination of knowledge through teaching and research;
- evidence that teaching and research are prime functions of the proposed university and qualifications and research performance of staff are comparable to those of recognised universities;
- evidence that courses will meet appropriate professional, national and international standards, and produce graduates who have good employment acceptability;
- existence of and capacity to maintain quality assurance processes which will allow objective and accountable review of academic activities.

(b) *The academic, and financial and staffing resources of the University which would be available in Victoria.*

The proposed university's resources and infrastructure must be at a level sufficient to sustain a broad range of teaching, scholarship and research.

Forms of evidence might include:

- Staffing ratios
- library resources
- equipment for research and teaching
- levels of support staff
- staff professional development arrangements
- existence of a strategic plan and mission to further enhance the proposed university's infrastructure and teaching and research ambitions
- procedures which result in rational determination of resource allocations

(c) *The views or recommendations of any relevant industrial or professional body about the courses of study to be offered by the University*

Forms of evidence might include:

- documentary evidence that the courses of the proposed university have met or will meet entry criteria prescribed by relevant professional, industrial or registering bodies;
- opinions of professional bodies about the standard of the courses of study and the resources provided.

2.2 Indicators of Actual or Expected Performance Relating to the Criteria

The following indicators of performance will be taken as representing minimum standards:-

- at least 25 percent of all academic staff (both full and part-time) have or will have a relevant doctorate or equivalent professional qualification and research experience;
- an average of at least 0.5 refereed publications per annum per equivalent full-time staff member;
- an average of at least one competitive external research grant per annum per 20 equivalent full-time staff at the level of lecturer and above;
- non-academic staff associated with the conduct of the proposed university of an appropriate nature and number and in comparable proportions to those of public universities offering similar programs.

Issued by the Minister for Tertiary Education and Training under Section 10 (4) of the **Tertiary Education Act 1993** on the Twenty-Sixth day of March 1999.

THE HON. PHIL HONEYWOOD MP
Minister for Tertiary Education and Training

Geographic Place Names Act 1998

1. NOTICE OF REGISTRATION OF GEOGRAPHIC NAMES

The Registrar of Geographic Names hereby gives notice of the registration of the undermentioned place names.

File No.	Place Name	Proposer & Location
171	Aire Valley, Alvie, Apollo Bay, Balintore, Barongarook, Barongraook West, Barramunga, Barunah Plains, Barwon Downs, Beeac, Beech Forest, Birregurra, Bungador, Cape Otway, Carlisle River, Carpendeit, Chapple Vale, Colac, Colac East, Colac West, Coragulac, Cororooke, Corunnun, Cressy, Cundare, Cundare North, Dreeite, Dreeite South, Elliminyt, Eurack, Ferguson, Forrest, Gellibrand, Gellibrand Lower, Gerangamete, Glenaire, Grey River, Horden Vale, Irrewarra, Irwillipe, Irwillipe East, Jancourt East, Johanna, Kawarren, Kennedys Creek, Kennett River, Larpent, Lavers Hill, Marengo, Mount Sabine, Murroon, Nalangil, Ombersley, Ondit, Pennyroyal, Petticoat Creek, Pirron Yallock, Separation Creek, Simpson, Skenes Creek, Skenes Creek North, Stonyford, Sugarloaf, Swan Marsh, Tanybryn, Warncoort, Warrion, Weaproinah, Weering, Whoorel, Winchelsea, Wingeel, Wongarra, Wool Wool, Wye River, Wyelangta, Yoe, Yeodene, Yuulong.	Colac Otway Shire. Entry into the Register of the 79 aforementioned urban and rural locality names and their boundaries within the municipality. The plans showing the names and boundaries may be inspected at the Municipal Offices, or at the Office of the Registrar of Geographic Names.

2. NOTICE OF PROPOSAL TO ENTER PLACE NAMES INTO THE REGISTER

The Registrar of Geographic Names hereby gives notice to propose to enter into the register the undermentioned place names. Any objections to the proposed name must be in writing (stating the reasons therefore) and be lodged with the Registrar within two months of the publication of this notice.

File No.	Place Name	Proposer & Location
	Aberfeldy, Ada, Allambee, Allambee Reserve, Allambee South, Amor, Athlone, Baw Baw, Baw Baw Village, Bonna Vista, Boola, Brandy Creek, Buln Buln, Buln Buln East, Caringa, Childers, Cloverlea, Coalville, Coopers Creek, Crossover, Darnum, Delbum, Driffield, Drouin, Drouin East,	Proposal from the Shire of Baw Baw to register the names and define the boundaries of the 97 aforementioned urban and rural localities

Drouin South, Drouin West, Ellinbank, Erica, Ferndale, Fumina, Gainsborough, Gentle Annie, Glengarry North, Hallora, Hallston, Heath Hill, Hernes Oak, Hill End, Icy Creek, Jacob Creek, Jericho, Jindivick, Labertouche, Lardner, Lillico, Loch Valley, Longwarry, Longwarry North, Mirboo North, Modella, Moe, Moe South, Moondarra, Mountain View, Narracan, Nayook, Neerim, Neerim East, Neerim Junction, Neerim North, Neerim South, Nilma, Nilma North, Noojee, Nyora, Poowong East, Poowong North, Rawson, Ripplebrook, Rokeby, Seaview, Shady Creek, Strzelecki, Tanjil, Tanjil Bren, Tanjil South, Tetoora Road, Thaloo, Thomson, Thorpdale, Thorpdale South, Toombon, Toongabbie, Trafalgar, Trafalgar East, Trafalgar South, Trida, Vesper, Walhala, Warragul, Warragul South, Warragul West, Westbury, Willow Grove, Yalloum North, Yarragon and Yarragon South.

Avenel, Beveridge, Broadford Bylands, Clonbinane, Flowerdale, Glenaroua, Heathcote Junction, Heathcote South, Highlands, Hilldene, Kerrisdale, Kilmore, Mangalore, Mia Mia, Northwood, Nulla Vale, Puckapunyal, Pyalong, Reedy Creek, Seymour, Tallarook, Tarcombe, Tooborac, Trawool, Tyaak, Upper Plenty, Wallan, Wandong, Waterford Park and Whiteheads Creek.

1604 Allestree, Bahgallah, Bessiebelle, Bolwarra, Branxholme, Breakaway Creek, Brimboal, Byaduk, Cape Bridgewater, Carapook, Cashmore, Casterton, Chetwynd, Clover Flat, Condah, Corndale, Dartmoor, Dergholm, Digby, Drik Drik, Drumbong, Dunrobin, Dutton Way, Gorae, Gorae West, Grassdale, Greenwald, Heathmere, Henty, Heywood, Homerton, Hotspur, Killara, Lake Condah, Lake Mundi, Lindsay, Lyons, Merino, Milltown, Mount Richmond, Mumbannar, Muntham, Myamyn, Nangeela, Nareen, Narrawong, Nelson,

Proposal from the Shire of Mitchell to register the names and define the boundaries of the 31 aforementioned urban and rural localities.

Proposal from Glenelg Shire to register the names and define the boundaries of the 60 aforementioned urban and rural localities.

Paschendale, Portland, Portland
 North, Portland West, Sandford,
 Strathdownie, Tahara, Tahara
 Bridge, Tahara West, Tyrendarra,
 Wallacedale, Wando Vale, Warrock,
 Winnap.

CORRIGENDUM

The Victoria Government Gazette No. G11, page 674, under Notice of Proposal to Enter Place Names into the Register, the mentioned Place name of Cargarie, within the Shire of Moorabool, should read Cargerie.

Office of the Registrar of Geographic Names
 c/-LAND VICTORIA
 2nd Floor
 456 Lonsdale Street
 MELBOURNE 3000
 Geographic Names

JOHN PARKER
 Registrar

Transport Act 1983

DISCONTINUANCE OF ROADS OR PARTS OF ROADS AND SALE OF SURPLUS LAND

The Roads Corporation, in pursuance of the powers conferred by Clause 2 Schedule 4 of the **Transport Act 1983**, upon publication of this notice hereby discontinues the roads or parts of roads shown cross hatched on the plan hereunder and approves the sale of surplus land as provided in Section 47 of the **Transport Act 1983** and as delegated by the Minister of Transport under Section 32 of the Act.

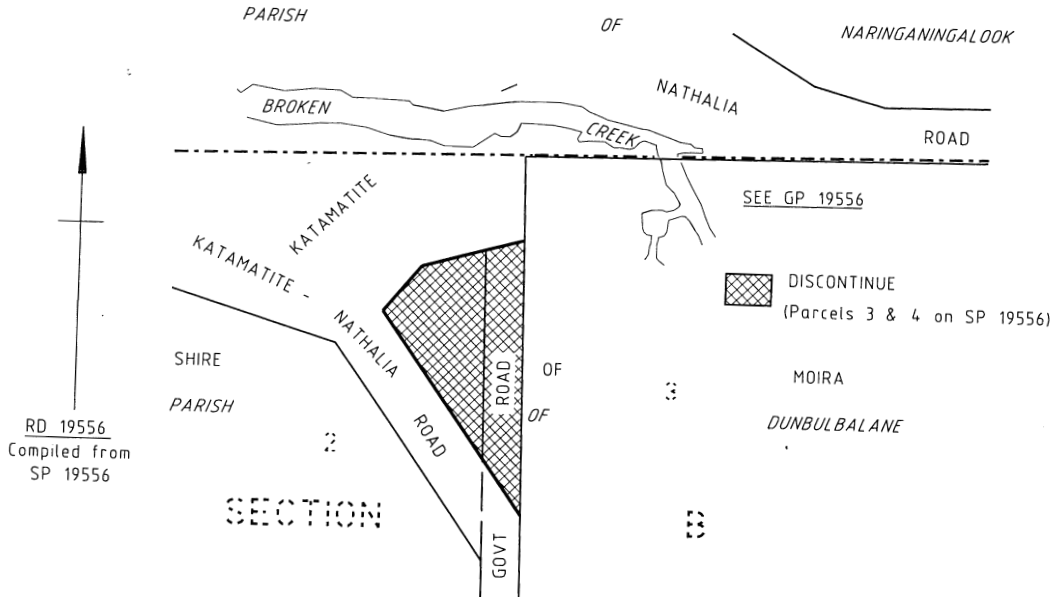

Dated 24 March 1999

COLIN JORDAN
 Chief Executive
 Roads Corporation

Transport Act 1983

ROAD DECLARATIONS AND DEDICATIONS

The Roads Corporation pursuant to the **Transport Act 1983**, upon publication of this notice declares, or varies the declaration of, the roads as described below and on the plans attached, and further declares that such roads are fit to be used as a public highway and are now absolutely dedicated to the public for use as public highways within the meaning of any law now or hereafter in force.

MAIN ROAD

- 11/99 Furlong Road in the City of Brimbank shown hatched on plan numbered GP 181 - MR.
- 12/99 Furlong Road in the City of Brimbank shown hatched and cross hatched on plan numbered GP 18477C.
- 13/99 Katamatite - Nathalia Road in the Shire of Moira shown hatched and cross hatched on plan numbered GP 19556.

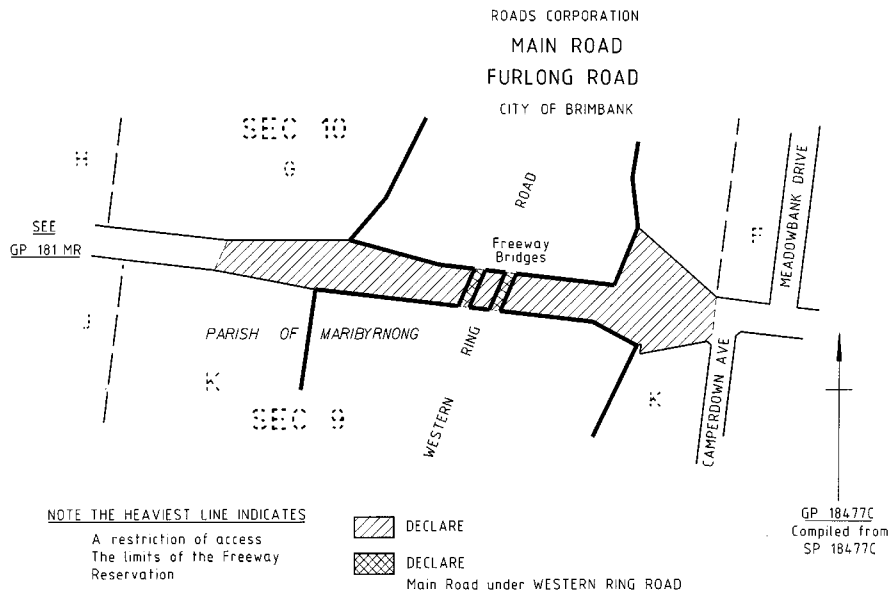
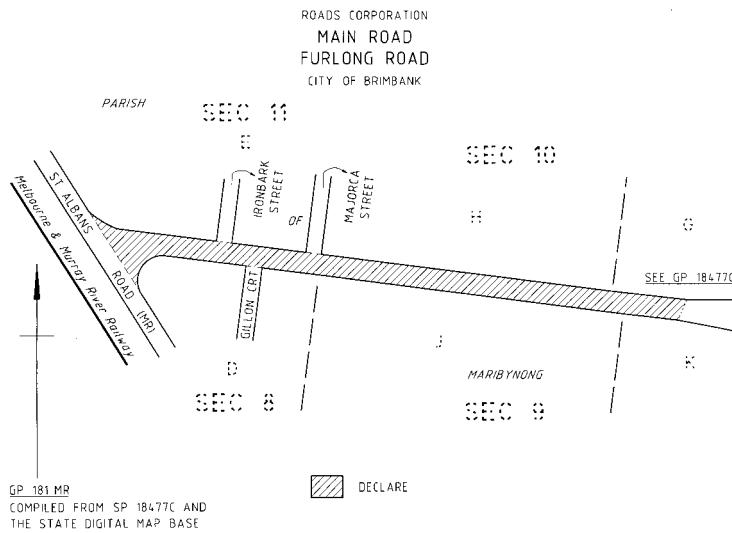

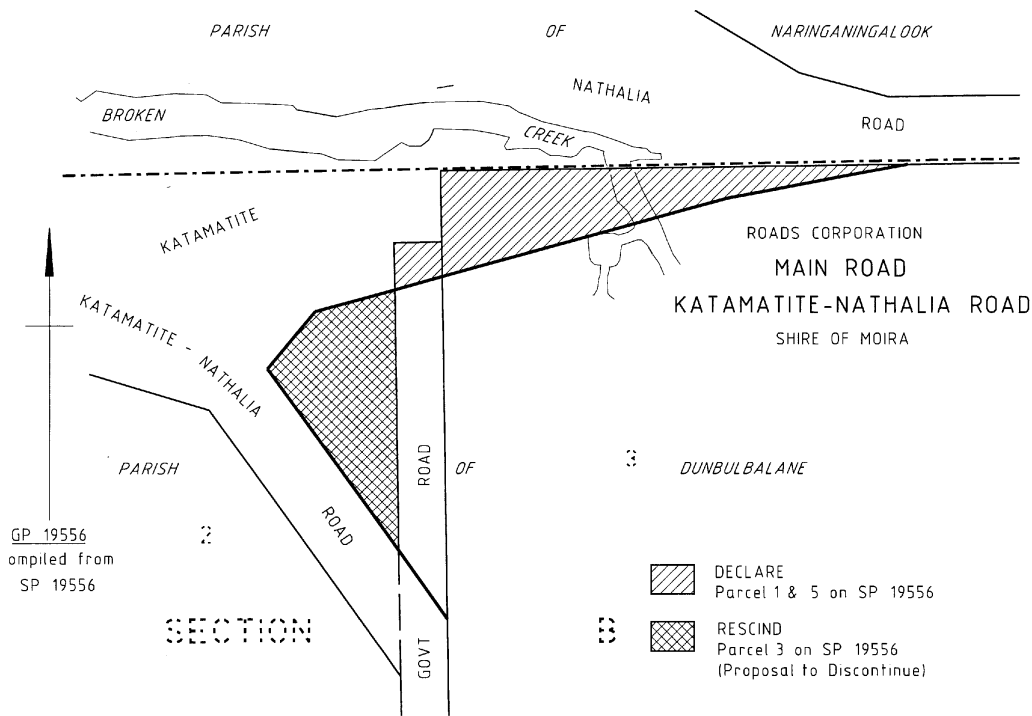

Dated 24 March 1999.

COLIN JORDAN
Chief Executive
Roads Corporation

Transport Act 1983
CORRIGENDUM

In the Victoria Government Gazette No. G10 dated 11 March 1999, page 587, under the notice **Transport Act 1983 - ROAD DECLARATIONS - DEDICATIONS** the iteration "of this" in the first line of the paragraph is deleted and in the penultimate line of the first paragraph the word "holidays" should read "highways".

D. J. PURDUE
Acting Statutory Planning Manager

Notice of any objection to the granting of an application should be forwarded to reach the Manager, Licensing & Certification, Victorian Taxi Directorate, Level 6, 14-20 Blackwood Street, North Melbourne (P.O. Box 666, North Melbourne 3051) not later than 29 April 1999.

Copies of objections are forwarded to the applicants.

It will not be necessary for interested parties to appear on the date specified, unless advised in writing by the Department.

Transport Act 1983
VICTORIAN TAXI DIRECTORATE
Department of Infrastructure

Commercial Passenger Vehicle Applications

Notice is hereby given that the following applications will be considered by the Victorian Taxi Directorate, a division of the Department of Infrastructure after 5 May 1999.

Aulia Pty Ltd, Hawthorn. Application for variation of conditions of licence SV1882 which authorises the licensed vehicle to operate in respect of a 1996 or later model Toyota van with seating capacity of less than 12 seats to change the vehicle to a 1996 or later model Chrysler, Ford, Holden, Honda, Lexus, Mazda, Mercedes Benz, Mitsubishi, Musso, Toyota, Volkswagen with seating capacity of less than 12 seats.

Dia Lin Pty Ltd, Strathdale. Application to license one commercial passenger vehicle to be purchased in respect of a 1998 or later model Ford station wagon or similar vehicle with seating capacity for 5 passengers to operate a service for the carriage of:-

- senile patients
- psychiatric (non-violent) patients
- IV dependant patients
- Patients with indwelling urinary catheters
- Recent stoma patients
- Patients with visible medical conditions
- Patients with communicable diseases
- Patients with a number of diseases of the elderly

between their place of residence and hospitals or any similar institution situated throughout the State of Victoria dependent on doctor or hospital authorisation.

Note:-

Patients will be picked up/set down anywhere throughout the State of Victoria.

J. Fieschi, Fawkner. Application for variation of conditions of licence SV1691 which authorises the licensed vehicle to operate in respect of a 1983 Cadillac sedan with seating capacity for 4 passengers to change the vehicle to any of the following vehicles:-

- 1973 Corvette coupe seating capacity for 1 passenger
- 1957 Chevrolet sedan seating capacity for 4 passengers
- 1987 Ford stretched limousine seating capacity for 7 passengers; and

to include the ability to operate for special occasions.

Garage Biarritz Pty Ltd, Daylesford. Application to license two commercial passenger vehicles to be purchased in respect of 1981 Cadillac stretched limousines each with seating capacity for 6 passengers to operate a service from Unit 5, Mineral Water Drive, Daylesford as follows:-

- (i) for the carriage of passengers for wedding parties, debutante balls, winery tours, day trips, sightseeing tours, business conferences and funerals within the Daylesford/Shire Of Hepburn Region; and

- (ii) for airport transfers to and from Melbourne Airport, Tullamarine.

Note:-

Passengers will be picked up/set down from within a 50km radius of the Daylesford Post Office.

Kelbec Tours Pty Ltd, Rowville. Application to license one commercial passenger vehicle to be purchased in respect of a 1986 Mercedes Benz coach with seating capacity for 48 passengers to operate as a metropolitan special omnibus from within a 55km pick-up radius of the Melbourne GPO.

S. Kobayashi, North Melbourne. Application for variation of conditions of licence SV884 which authorises the licensed vehicle to operate in respect of a 1986 or later model air-conditioned Ford LTD or Fairlane sedan with seating capacity for 4 passengers to change the vehicle to a 1996 or later model Toyota Tarago wagon with seating capacity for 8 passengers.

K. D. & V. V. Ly, Springvale. Application to license one commercial passenger vehicle to be purchased in respect of a 1990 or later model Scania or MAN bus with seating capacity of up to 50 passengers to operate a service from 38 Ellen Street, Springvale for the carriage of passengers to various places of interest throughout the State of Victoria.

Note:-

Passengers will be picked up/set down from within a 30km radius of the Melbourne GPO.

Mandeville Nominees Pty Ltd, Sunbury. Application to license one commercial passenger vehicle in respect of any vehicle that meets the standards approved by the Victorian Taxi Directorate to operate as a hire car from 8 Turner Court, Sunbury.

Note:-

Applicant will operate in conjunction with Personalised Hire Cars and Sunbury Chauffeur Drive.

J. H. Trenfield, Park Orchards. Application to license one commercial passenger vehicle in respect of a 1987 Austral coach with seating capacity for 48 passengers to operate as a metropolitan special service omnibus from within a 55km pick-up radius of the Melbourne GPO.

S. H. Yih, Wheelers Hill. Application to license two commercial passenger vehicles in respect of one 1990 or later model Mercedes Benz, MAN or Scania bus with seating capacity of up to 45 passengers and one 1994 Mazda bus with seating capacity for 16 passengers to operate as metropolitan special service omnibuses from within a 55km pick-up radius of the Melbourne GPO.

Dated 1 April 1999.

ROBERT STONEHAM
Manager - Operations
Victorian Taxi Directorate

Office of the Regulator-General Act 1994

NOTICE OF DETERMINATION

On 24 March 1999 the Office of the Regulator-General determined in accordance with clause 5.2.17 of the Tariff Order that Kaadan Pty Ltd, Conrad Street, St Albans; and Perseverance Exploration Pty Ltd, Fosterville should be assigned to Powercor's "medium 5 day 2 rate" network tariff.

The determination takes effect on and from the date in which this notice is published in the Victoria Government Gazette.

A copy of the determination may be obtained by written request addressed to the Office of the Regulator-General, Level 1, 35 Spring Street, Melbourne 3000.

JOHN TAMBLYN
Regulator General

Adoption Act 1984

SECTIONS 21 AND 22

Application for Approval as an Adoption Agency

Under the provisions of Section 10(2) of the **Community Services Act 1970** I have been assigned the functions and powers of the Secretary of Department of Human Services under Sections 21 and 22 of the **Adoption Act 1984**.

After considering an application from the following welfare organisation, I have approved it as an "approved agency" for the purposes of conducting negotiations and making arrangements for the adoption of children, in accordance with section 22 of the **Adoption Act 1984**.

Child and Family Services Ballarat Inc.
115 Lydiard Street
Ballarat 3350

Principal Officer: Aileen Wilson

This approval is for a period of three years from the date of this notice unless suspended or revoked at an earlier date.

Dated 23 March 1999.

YEHUDI BLACHER
Director
Youth and Family Services

Nurses Act 1993

NURSES BOARD OF VICTORIA

Safeguarding the public through professional practice

On 24 February 1999, a panel appointed by the Nurses Board of Victoria, found that Cheryl May Parker of 3 Riddell Road, Wantirna South, Victoria, identification number 97491, registered in division 2, had engaged in unprofessional conduct of a serious nature.

The panel determined that:-

- 1- Pursuant to s. 48(2)(c) **Nurses Act 1993**, the nurse be reprimanded.
- 2- Pursuant to s. 48(2)(a) of the Act, the nurse undergo counselling and consultations for at least 12 months with a psychiatrist approved in writing by the Board, such consultations to commence as soon as possible, and to occur at least once a month, or oftener if the psychiatrist so recommends. Within one month of the anniversary of the first consultation, the nurse must provide the Board with a written report from the psychiatrist of the counselling and consultations, which report must be satisfactory to the Board.
- 3- Pursuant to s. 48(2)(d) of the Act, the nurse must enrol in, and by 30 June 2000 provide the Board with written evidence of satisfactory completion of, course modules in:-
 - (a) professional ethics; and
 - (b) behavioural management of aggressive geronic residents,
 each course module and institution to be approved in writing by the Board before each course commences.

BARBARA CARTER
Acting Chief Executive

Nurses Act 1993**NURSES BOARD OF VICTORIA****Safeguarding the public through professional practice**

On 24 February 1999, a panel appointed by the Nurses Board of Victoria, found that Aleida Catharina Maria Byers of 14 Gum Hill Road, Langwarrin, Victoria, identification number 3875, registered in division 2, had engaged in unprofessional conduct of a serious nature.

The panel determined that:-

- 1- Pursuant to s. 48(2)(c) **Nurses Act 1993**, the nurse consult and undergo counselling for at least 12 months with a psychiatrist approved in writing by the Board, such consultations to commence as soon as possible, and to occur at least once a month, or more often if the psychiatrist so recommends. Within one month of the end of the 12 month period, the nurse must produce to the Board a report from the psychiatrist of the consultations and counselling, which report must be satisfactory to the Board.
- 2- Pursuant to s. 48(2)(a) of the Act, the nurse's registration is suspended, with effect from 31 March 1999.
- 3- After 30 June 1999, the nurse may apply in writing to remove the suspension of her registration, but only if the following conditions are and have been observed:-
 - (a) From 31 March 1999 until the suspension of her registration is removed, the nurse may not work, in any capacity, for:
 - (i) a registered funded agency; or
 - (ii) a health service establishment,
 as those terms are defined in s. 3 **Health Service Act 1998** of Victoria, nor as or for a nurse's agent, as defined in s. 3 **Nurses Act 1993**.
 - (b) Before she applies to remove the suspension, she must have attended at least 2 consultations with a psychiatrist pursuant to paragraph 1 of this determination.
 - (c) With her application to remove the suspension, she must produce a letter from the psychiatrist which:-
 - (i) includes a report on the consultations and counselling to that date, which is acceptable to the Board; and

- (ii) satisfies that in the psychiatrist's opinion, she is fit to recommence practice as a division 2 nurse.

- 4- Pursuant to s. 48(2)(d) **Nurses Act 1993**, within 12 months of removal of suspension of her registration, the nurse must enrol in and produce to the Board written evidence of her satisfactory completion of, a course module in behavioural management of aggressive geriatric residents, the course and institution to be approved in writing by the Board before the course commences.

BARBARA CARTER
Acting Chief Executive

Land Act 1958

Notice is hereby given that the Scouts Victorian Branch and the Guides Victoria have applied for a lease pursuant to section 134 of **Land Act 1958** for a term of 21 years in respect of Allotment 8, Section 2A, Township of Woodend containing 1820 sqm more or less situated at Forest Street, Woodend, for the purpose of Scout and Guide Hall and other associated purposes therewith.

Victoria Racing Club Act 1871**NOTICE OF AMENDMENT OF BY-LAWS**

Notice is given that the Committee of the Victoria Racing Club pursuant to Section 14 of the **Victoria Racing Club Act 1871**, at a meeting held on 1 January 1999, resolved that a new By-Law 14A be inserted as follows:

"14A Without limiting the generality of By-Law 14, the Committee shall have the power to guarantee and give guarantees and indemnities (either jointly or severally) for the payment of money or the performance of contracts of any person or body corporate as the Committee may deem desirable for carrying out the objects of the Club."

A copy of this amendment to the By-Laws was sent to the Minister for Sports on 29 January 1999, has been reviewed and has not been disallowed.

By-Law 14A will come into operation on the date of publication of this notice in the Victorian Government Gazette.

ANDREW RAMSDEN
Chairman
Victoria Racing Club

Stamps Act 1958

NOTICE UNDER SECTION 40A

Pursuant to section 40A of the **Stamps Act 1958** I hereby declare and make effective from the date indicated below, that:

AP 152 United Premium Funding Limited

to be no longer an "Authorised Person" effective from 28 February 1999 in relation to the stamping of Mortgages, Bonds, Debentures and Covenants.

Dated Tuesday 23 March 1999.

DAVID POLLARD
Commissioner for State Revenue

Stamps Act 1958

NOTICE UNDER SECTION 40A

Pursuant to section 40A of the **Stamps Act 1958** I hereby declare and make effective from the date indicated below, that:

AP 337 JB Were Equity Finance Limited

to be no longer an "Authorised Person" effective from 23 March 1999 in relation to the stamping of Transfers of Land, Mortgages, Bonds, Debentures and Covenants, Marketable Securities, Leases, Agreements to Lease, Assignments or Transfers of Lease and Instruments of Settlement.

Dated Tuesday 23 March 1999.

DAVID POLLARD
Commissioner for State Revenue

Water Act 1989DECLARATION OF THE EXTENSION TO
THE ALEXANDRA SEWERAGE DISTRICT
ORDER 1998

1. This Order is called the Declaration of the Extension to the Alexandra Sewerage District - Order 1998.
2. This Order is made under Section 96(11)(a) of the **Water Act 1989** and all other available powers.
3. This Order takes effect from the date it is published in the Government Gazette.
4. The proposal for the declaration of the extension to the sewerage district submitted to the Department of Natural Resources and Environment by the Goulburn Valley Region Water Authority on 5 March, 1999 is

approved by the Minister.

5. (a) An extension to the existing Alexandra Sewerage District is declared;
- (b) The extension to the Alexandra Sewerage District is the land within the red border on the accompanying plan No. 090/010/24-1, a copy of which may be inspected at the offices of the Goulburn Valley Region Water Authority, situated at 104-110 Fryers Street, Shepparton; and
- (c) The Goulburn Valley Region Water Authority is nominated to manage and control the Alexandra Sewerage District.

Dated 24 March 1999.

L. J. GLEESON
Chief Executive

The Constitution Act Amendment Act 1958

VICTORIAN ELECTORAL COMMISSION

Notice of Application for Registration of a
Political Party

The following application has been received for registration of a political party under Victoria's electoral law.

Proposed name of party: Phil Cleary — Independent Australia.

Name and address of proposed registered officer: Bernard Sanaghan, 11 Scotia Street, West Preston, Vic. 3072.

The application is made, and signed by, ten members of the party. The application states their names and addresses as follows:

Philip Cleary	21 Hoffman Street, Brunswick West
Eileen Zombolas	63 Hurtle Street, Ascot Vale
Valerie Keane	16 Whitby Street, Brunswick West
Bernard Sanaghan	11 Scotia Street, West Preston
Donna Cleary	17 James Street, West Preston
Christine James	21 Hoffman Street, Brunswick West
Michael Phillips	16 Hoffman Street, Brunswick West

Veronica Phillips 16 Hoffman Street,
Brunswick West

Lynn Coceani 5 Francis Street, Coburg

Lucio Coceani 5 Francis Street, Coburg.

In its application, the party states that it has or operates under a constitution, a copy of which accompanied the application.

Any persons who believe that this application:

- (i) does not relate to an eligible political party (an eligible political party is a political party that has at least five hundred members as required by section 148A(1) of **The Constitution Act Amendment Act 1958**);
- (ii) is not in accordance with section 148D of the above Act; or
- (iii) should be refused under section 148G of the above Act, in that the name of the party, the abbreviation or initials of the name that the party wishes to be able to use for the purposes of the Act is too long, is obscene, or is the name (or too closely resembles the name) of another political party — not being a political party that is related to the party to which the application relates — that is a Parliamentary party or registered political party;

are invited to submit written particulars of the grounds for that belief to the Electoral Commissioner by Monday, 3 May 1999.

Particulars submitted by a person in response to this notice must be signed by, and specify an address of, that person and must be sent to the Electoral Commissioner, Victorian Electoral Commission, Level 8, 505 Little Collins Street, Melbourne, Vic. 3000.

Any inquiries may be directed to Mr Doug Beecroft, Manager, Public Information and Corporate Services, Victorian Electoral Commission, on (03) 9287 7455.

This notice is placed as required by section 148K of the **The Constitution Act Amendment Act 1958**.

C. A. BARRY
Electoral Commissioner

Wildlife (Game) Regulations 1990

NOTIFICATION OF LOCATIONS, OPENING TIMES AND REQUIREMENTS AT CHECKING STATIONS FOR HOG DEER

Under regulation 40(2) of the Wildlife (Game) Regulations 1990 (the Regulations), the Secretary to the Department of Natural Resources and Environment gives notice that-

1. Pursuant to regulation 40(1) of the Regulations the Secretary has nominated the places specified in the Schedule below as checking stations for the purpose of recording biological, physical and other information about Hog Deer taken by hunters during the open season; and
2. The checking stations are located at the addresses specified in the Schedule and are open at the times specified in the Schedule, and
3. Pursuant to regulation 40(3)(b) of the Regulations the Secretary requires that upon taking a Hog deer carcass to a checking station hunters must provide the jawbone from each Hog Deer carcass for the purpose of examination for any disease or disorder.

SCHEDULE

Bairnsdale

11 Morekena Crescent, Bairnsdale
Hours of operation - all hours by appointment
Telephone number - 018 109 504

Golden Beach

906 Dolphin Avenue, Golden Beach
Hours of operation - 10:00 am to 9:00 pm,
Friday to Monday
- 5:00 pm to 9:00 pm, Tuesday, Wednesday,
Thursday
Telephone number - (03) 5146 3217

Leongatha

Leongatha Kitchens and Building Supplies, 25
Hughes Street, Leongatha
Hours of operation - 8:00 am to 9:00 pm daily
Business and after hours telephone number -
(03) 5662 3736

Traralgon

20 Peterkin Street, Traralgon
Hours of operation - all hours, by appointment
Telephone number - 014 407 682

Sunday Island

Sunday Island (members of Para Park Cooperative Game Reserve Ltd only)

Hours of operation - all hours

Telephone number - (03) 5182 5959

NOTE.

The open season for Hog Deer is from 30 minutes before sunrise on the first day in April until 30 minutes after sunset on the last day of April.

By authority, the seal of the Secretary to the Department of Natural Resources and Environment was affixed to this instrument on 25 March 1999

by Michael J. Taylor

Sharon Otto: Witness.

The Seal of the Secretary
to the Department of
Natural Resources and Environment

Children and Young Persons Act 1989

**APPOINTMENT OF HONORARY
PROBATION OFFICERS**

I, Gabrielle Levine, (Regional Director) of Department of Human Services Western Region, under Section 34(4) of the **Children and Young Persons Act 1989** appoint the undermentioned persons as Honorary Probation Officers for the Children's Court in the State of Victoria for the period ending 31 December 2001.

Danielle Panebianco

Thu-Tram Trinh-Truong.

I, Gabrielle Leving, (Regional Director) of Department of Human Services Western Region, under Section 34(4) of the **Children and Young Persons Act 1989** revoke the undermentioned persons as Honorary Probation Officers for the Children's Court in the State of Victoria for the period ending 31 December 2001.

Danielle Panabianco

Thu-Tram Truong.

Dated 23 March 1999.

GABRIELLE LEVINE
Regional Director

Forests Act 1958, No. 6254

VARIATION OF PROHIBITED PERIODS

In pursuance of the powers conferred by section 3 sub section (2) of the **Forests Act 1958**, I, Gary Morgan, delegated officer for the Minister for Conservation and Land Management in the State of Victoria, hereby vary the declaration of the Prohibited Period with respect to the fire protected area (other than State forest, National park and protected public land) within the municipalities nominated for the period specified in the schedules below:

SCHEDULE 1

The Prohibited Period shall end at 01.00 hours on Monday 5 April 1999 in the following municipalities:

Murrundindi Shire Council

Delatite Shire Council

Towong Shire Council

Mitchell Shire Council

Alpine Shire Council

Rural City of Wodonga

Strathbogie Shire Council

Indigo Shire Council

Rural City of Wangaratta

GARY MORGAN
Chief Fire Officer

Department of Natural Resources
and Environment

Delegated Officer, pursuant to section 11,
Conservation Forests and Land Act 1987

Country Fire Authority Act 1958

VARIATION OF FIRE DANGER PERIOD

IN PURSUANCE of the powers conferred by Section 4 of the **Country Fire Authority Act 1958**, I, Leonard Raymond Foster, Chairman of the Country Fire Authority, after consultation with the Secretary of Natural Resources and Environment, hereby vary the declaration of the Fire Danger Periods previously published in the Government Gazette by declaring that such Fire Danger Periods shall end in respect of the undermentioned Municipal Districts of Municipalities or parts of Municipalities specified.

To terminate from 01.00 hours on Monday 5 April, 1999:

Mitchell Shire Council
Murrindindi Shire Council
Moira Shire Council
Strathbogie Shire Council (Remainder) That part south of the Hume Freeway.
Rural City of Wangaratta
Delatite Shire Council
Alpine Shire Council
Indigo Shire Council
Towong Shire Council
Wodonga Rural City Council
Corangamite Shire Council

To terminate from 01.00 hours on Tuesday 6 April, 1999:

West Wimmera Shire Council (Remainder)
Glenelg Shire Council
Southern Grampians Shire Council (Remainder)
L. FOSTER
Chairman

Melbourne City Link Act 1995

NOTICE OF VARIATION TO THE AGREEMENT FOR THE EXHIBITION STREET EXTENSION PROJECT AND OF THE PUBLICATION OF "STATEMENT OF VARIATION NO. 3/1999: ESEP CONTRACT SUM PAYMENT DIRECTIONS AGREEMENT"

Notice is hereby given of a variation to the provisions of the Agreement for the Exhibition Street Extension Project ("the Extension Agreement") made in accordance with the terms of that Agreement and section 15D of the **Melbourne City Link Act 1995**.

The variation consists of the execution of the "ESEP Contract Sum Payment Directions Agreement". Several provisions of the Extension Agreement (as amended by the Exhibition Street Extension First Amending Deed) define rights and obligations of the parties to that Agreement by reference to the ESEP Contract Sum Payment Directions Agreement.

The variation comes into operation on the date this notice is published in the Government Gazette.

The Statement of the Variation (called "Statement of Variation No. 3/1999: ESEP Contract Sum Payment Directions Agreement")

may be inspected free of charge during office hours at:-

- (a) The Plan Inspection Office, Department of Infrastructure, Level 3 Plaza, Nauru House, 80 Collins Street, Melbourne 3000;
- (b) the offices of the Melbourne City Link Authority, Level 13, Nauru House, 80 Collins Street, Melbourne 3000.

Dated: 30 March 1999.

RICHARD PARKER
Chief Executive
Melbourne City Link Authority

Planning and Environment Act 1987

BAW BAW PLANNING SCHEME

Notice of Approval of Amendment

Amendment C5

The Minister for Planning and Local Government has approved Amendment C5 to the Baw Baw Planning Scheme.

The Amendment comes into operation on the date this notice is published in the Government Gazette.

The Amendment: 1) rezones Crown Allotments 6 (part), 1, 2, and 5, Section 1, Crown Allotments 18 (part), 6, 8, 9, 13, 14 and 15, Section 4, Crown Allotments 1, 3, 5, 7, 16 and 19, Section 2 and Crown Allotments 3, 5, and 6, Section 3, Crown Allotments 5 (part) and 2, Section 5, Township of Aberfeldy and part Crown Allotment 6 and Crown Allotment 12, Parish of Toombon and part Crown Allotment 1, Section C, Parish of Toombon from Public Use Zone – Service and Utility to Rural Zone; and 2) rezones part Crown Allotment 17, Section 4 and Crown Allotment 10, Section 7, Township of Aberfeldy from Rural Zone to Public Use Zone — Service and Utility.

A copy of the Amendment can be inspected, free of charge, during office hours, at the Department of Infrastructure, Customer Service Centre, Upper Plaza, Nauru House, 80 Collins Street, Melbourne and at the offices of the Baw Baw Shire Council, Civic Place, Warragul.

LEIGH PHILLIPS
Director, Planning Operations
Planning, Heritage
and Market Information
Department of Infrastructure

Planning and Environment Act 1987

BRIMBANK PLANNING SCHEME

Notice of Approval of Amendment

Amendment L53

The Minister for Planning and Local Government has approved Amendment L53 to the Brimbank Planning Scheme.

The Amendment comes into operation on the date this notice is published in the Government Gazette.

The Amendment rezones land at 18 Tallintyre Road, Sunshine from a Residential C zone to a Business 1 zone.

A copy of the Amendment can be inspected, free of charge, during office hours, at the Department of Infrastructure, Customer Service Centre, Upper Plaza, Nauru House, 80 Collins Street, Melbourne and at the offices of the Brimbank City Council, Old Keilor Highway, Keilor.

LEIGH PHILLIPS
Director, Planning Operations
Planning, Heritage
and Market Information
Department of Infrastructure

Planning and Environment Act 1987

GREATER GEELONG PLANNING SCHEME

Notice of Approval of Amendment

Amendment R221

The Minister for Planning and Local Government has approved Amendment R221 to the Greater Geelong Planning Scheme.

The Amendment comes into operation on the date this notice is published in the Government Gazette.

The Amendment rezones approximately 1200 square metres of land at 91-95 West Fyans Street, Newtown from Residential A to Service Business zone.

A copy of the Amendment can be inspected, free of charge, during office hours, at the Department of Infrastructure, Customer Service Centre, Upper Plaza, Nauru House, 80 Collins Street, Melbourne and at the offices of the City of Greater Geelong Council, Second Floor, 103 Corio Street, Geelong.

LEIGH PHILLIPS
Director, Planning Operations
Planning, Heritage
and Market Information
Department of Infrastructure

Planning and Environment Act 1987

HORSHAM PLANNING SCHEME

Notice of Approval of Amendment

Amendment L13

The Minister for Planning and Local Government has approved Amendment L12 to the Horsham Planning Scheme.

The Amendment comes into operation on the date this notice is published in the Government Gazette.

The Amendment declares the Minister for Planning and Local Government the responsible authority for the Planning Scheme as it applies to the area known as the Horsham Saleyards fronting Darlot, Hamilton and Madden Streets, Horsham, comprising CA's 54, 56, 57, 58, 59, 60, 60A, 61, 62, 63, 64, 65, 66, 67, 68, 69, 70, 71 Section 5, Lot 1 on P/S 413011T, Lot 1 on P/S 425569V and a triangular portion of Darlot Street (954 m²) immediately north of that lot, Township of Horsham.

A copy of the Amendment can be inspected, free of charge, during office hours, at the Department of Infrastructure, Customer Service Centre, Upper Plaza, Nauru House, 80 Collins Street, Melbourne and at the offices of the Western Region Office, 1315 Sturt Street, Ballarat and at the offices of the Horsham Rural City Council, Municipal Offices, Roberts Avenue, Horsham.

LEIGH PHILLIPS
Director, Planning Operations
Planning, Heritage
and Market Information
Department of Infrastructure

Planning and Environment Act 1987

HUME PLANNING SCHEME

Notice of Approval of Amendment

Amendment L54

The Minister for Planning and Local Government has approved Amendment L54 to the Hume Planning Scheme.

The Amendment comes into operation on the date this notice is published in the Government Gazette.

The Amendment rezones land at 4 Casablanca Court, Greenvale from Residential D zone to Reserved Living B zone and modifies the restrictive covenant applying to this land.

A copy of the Amendment can be inspected, free of charge, during office hours, at the Department of Infrastructure, Customer Service Centre, Upper Plaza, Nauru House, 80 Collins Street, Melbourne and at the offices of the Hume City Council, Macedon Street, Sunbury (also at 1079 Pascoe Vale Road, Broadmeadows).

LEIGH PHILLIPS
Director, Planning Operations
Planning, Heritage
and Market Information
Department of Infrastructure

Planning and Environment Act 1987

HUME PLANNING SCHEME
Notice of Approval of Amendment
Amendment L59

The Minister for Planning and Local Government has approved Amendment L59 to the Hume Planning Scheme.

The Amendment comes into operation on the date this notice is published in the Government Gazette.

The Amendment changes the category of advertising sign control that applies to land known as Certificate of Title Volume 8862 Folio 141, Volume 8862 Folio 142 and part Volume 9231 Folio 107 located at Western Avenue, Tullamarine from Category 9 to Category 2.

A copy of the Amendment can be inspected, free of charge, during office hours, at the Department of Infrastructure, Customer Service Centre, Upper Plaza, Nauru House, 80 Collins Street, Melbourne and at the offices of the Hume City Council, Macedon Street, Sunbury and Pascoe Vale Road, Broadmeadows.

LEIGH PHILLIPS
Director, Planning Operations
Planning, Heritage
and Market Information
Department of Infrastructure

Planning and Environment Act 1987

MOE PLANNING SCHEME
Notice of Lapsing of Amendment
Amendment L44

The La Trobe Shire Council has resolved to abandon Amendment L44 to the Moe Planning Scheme.

The Amendment proposed to remove the prohibition on the use and development of land for a Petrol station in various streets of Moe.

The Amendment lapsed on 1 March 1999, the date that Council resolved to abandon the amendment at the request of the proponent.

LEIGH PHILLIPS
Director, Planning Operations
Planning, Heritage
and Market Information
Department of Infrastructure

Planning and Environment Act 1987

TRARALGON (CITY) PLANNING SCHEME
Notice of Lapsing of Amendment
Amendment L72

The la Trobe Shire Council has resolved to abandon Amendment L72 to the Traralgon (City) Planning Scheme.

The Amendment proposed to allow a Service station to be used in the Commercial A Zone subject to the issue of a planning permit.

The Amendment lapsed on 1 March 1999, the date that Council resolved to abandon the amendment at the request of the proponent.

LEIGH PHILLIPS
Director, Planning Operations
Planning, Heritage
and Market Information
Department of Infrastructure

ORDERS IN COUNCIL

Fisheries Act 1995

**QUOTA ORDER FOR ABALONE
FISHERY UNDER SECTION 64 OF THE
FISHERIES ACT 1995**

The Governor in Council, acting under section 64(1) of the **Fisheries Act 1995** and on the recommendation of the Minister for Agriculture and Resources, makes the following Order.

1. This Order applies for the period starting on 1 April 1999 and ending on 31 March 2000 ("the quota year").
2. The Total Allowable Catch ("TAC") for the Abalone Fishery in the eastern abalone zone for the quota year is 460 tonnes of unshucked abalone.
3. The TAC for the Abalone Fishery in the central abalone zone for the quota year is 700 tonnes of unshucked abalone.
4. The TAC for the Abalone Fishery in the western abalone zone for the quota year is 280 tonnes of unshucked abalone.
5. An individual quota unit for the Abalone Fishery in the central abalone zone in the quota year is 1029 kg of unshucked abalone.
6. An individual quota unit for the Abalone Fishery in the eastern and western abalone zones in the quota year is 1000 kg of unshucked abalone.
7. Each Abalone Fishery Access Licence holder is to be allowed 20 individual quota units for the quota year.
8. An Abalone Fishery Access Licence holder must hold at all times during the quota year at least 10 individual quota units.
9. An Abalone Fishery Access Licence holder must not hold at any time during the quota year more than 30 individual quota units.
10. If an Abalone Fishery Access Licence holder holds more than one Abalone Fishery Access Licence, the Licence holder -
 - (a) must hold at all times during the quota year at least 10 individual quota units in relation to each Licence; and
 - (b) must not hold at any time during the quota year more than 30 individual quota units in relation to each Licence.

11. For the purposes of clauses 8, 9 and 10, in determining how many individual quota units are held at a particular time during the quota year in respect of a Licence, any individual quota units that have been taken under the Licence during the quota year before that particular time are to be counted.

This Order commences 1 April 1999.

Dated 30 March 1999.

Responsible Minister:

PATRICK McNAMARA

Minister for Agriculture and Resources

SHANNON DELLAMARTA

Acting Clerk of the Executive Council

Melbourne City Link Act 1995

DIVESTING OF LAND

The Governor in Council, on the recommendation of the Acting Minister for Planning and Local Government (being the Minister administering the **Melbourne City Link Act 1995**) and the Minister for Agriculture and Resources (being the Minister administering the provisions of the **Melbourne Water Corporation Act 1992** under which the Melbourne Water Corporation is established), under section 31(1)(b) of the **Melbourne City Link Act 1995** divests from the Melbourne Water Corporation the areas of 24m² and 17m² shown stipled on the plan numbered LEGL./99-23 lodged in the Central Plan Office.

Dated 30 March 1999

Responsible Minister:

GEOFF CRAIGE

Acting Minister for Planning
and Local Government

SHANNON DELLAMARTA

Acting Clerk of the Executive Council

Melbourne City Link Act 1995

**ORDER INCREASING THE PROJECT
AREA**

The Governor in Council, on the recommendation of the Acting Minister for Planning and Local Government (being the Minister administering the **Melbourne City Link Act 1995** and the Minister administering the **Planning and Environment Act 1987**),

under section 8(1)(a) of the **Melbourne City Link Act 1995** varies the Project area by increasing the Project area by adding the land shown hatched turquoise on the plan numbered LEGL./98-101 lodged in the Central Plan Office.

Dated 30 March 1999

Responsible Minister:
THE HON. GEOFF CRAIGE
Acting Minister for Planning
and Local Government

SHANNON DELLAMARTA
Acting Clerk of the Executive Council

Melbourne City Link Act 1995
SURRENDER OF INTERESTS IN
UNRESERVED CROWN LAND

The Governor in Council, on the recommendation of the Minister for Planning and Local Government (being the Minister administering the **Melbourne City Link Act 1995**) under section 26(2) of the **Melbourne City Link Act 1995** declares that the interests (if any) in the area of 225m² shown hatched with triangles on the plan numbered LEGL./97-1 lodged in the Central Plan Office are surrendered to the Crown.

Dated 30 March 1999

Responsible Minister:
ROBERT MACLELLAN
Minister for Planning
and Local Government

SHANNON DELLAMARTA
Acting Clerk of the Executive Council

Land Act 1958
SALE OF CROWN LAND
BY PRIVATE TREATY
Order in Council

The Governor in Council, pursuant to section 99A(1)(a) & 99A(2) of the **Land Act 1958**, approves the sale by private treaty of Crown Allotment 177A, Parish of Prahran and located in Castlebar Road, Chadstone.

Dated 30 March 1999

Responsible Minister:
ROGER M. HALLAM MLC
Minister for Finance

SHANNON DELLAMARTA
Acting Clerk of the Executive Council

Land Act 1958
SALE OF CROWN LAND
BY PRIVATE TREATY
Order in Council

The Governor in Council, pursuant to section 99A(1)(a) & 99A(2) of the **Land Act 1958**, approves the sale by private treaty of Crown Allotment 18A, Section 15, Parish of Melbourne North, located at 601 Bourke Street, Melbourne.

Dated 30 March 1999.

Responsible Minister:
ROGER M. HALLAM MLC
Minister for Finance

SHANNON DELLAMARTA
Acting Clerk of the Executive Council

Crown Land (Reserves) Act 1978
NOTICE OF INTENTION

The Governor in Council under Section 10 of the **Crown Land (Reserves) Act 1978** gives notice of intention to revoke the following temporary reservations to the extent indicated hereunder:

BRIGHT — The temporary reservation by Order in Council of 18 July, 1961 of a total area of 2.63 hectares, more or less, of land in Section U, Parish of Bright (in two separate portions), as a site for Tourist Camping purposes, so far only as the portion containing 8200 square metres, more or less, as indicated by hatching on plan hereunder. — (B574[12]) — (Rs 8053).

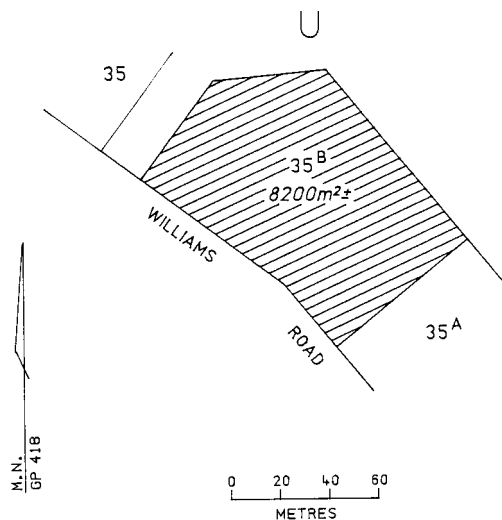

MINYIP — The whole of the temporary reservation by Order in Council of 24 March, 1987 of an area of 2.281 hectares of land being Crown Allotment 2A, Section 31, Township of Minyip, Parish of Nullan as a site for an Ornamental Plantation. — (Rs 13424).

MINYIP — The whole of the temporary reservation by Order in Council of 2 October, 1973 of an area of 8030 square metres of land in Section 29, Township of Minyip, Parish of Nullan as a site for Public Purposes (Tree Plantation). — (Rs 9772).

MINYIP — The whole of the temporary reservation by Order in Council of 2 October, 1973 of an area of 1.048 hectares of land (in two separate portions in Section 27 and 30) in the Township of Minyip, Parish of Nullan as sites for Public Purposes (Tree Plantation). — (Rs 9772).

This Order is effective from the date on which it is published in the Victoria Government Gazette.

Dated 30 March 1999

Responsible Minister:
MARIE TEHAN
Minister for Conservation
and Land Management

SHANNON DELLAMARTA
Acting Clerk of the Executive Council

Crown Land (Reserves) Act 1978

NOTICE OF INTENTION

The Governor in Council under Section 10 of the **Crown Land (Reserves) Act 1978** gives notice of intention to revoke the following temporary reservations:

BARRARBOOL — The temporary reservation by Order in Council of 29 March, 1983 of an area of 1065 square metres of land being Crown Allotment 9A, Crown Portion 9, Parish of Barrarbool as a site for Health Commission purposes. — (Rs 12171).

EUMEMMERRING — The temporary reservation by Order in Council of 22 December, 1970 of an area of 2023 square metres of land in Crown Portion 16, Parish of Eumemmerring as a site for Public purposes (Social Welfare Department purposes) — (Rs 9403).

MOORPANYAL — The temporary reservation

by Order in Council of 21 January, 1986 of an area of 776 square metres of land being Crown Allotment 96A, Parish of Moorpanyal as a site for Health purposes. — (Rs 12683).

PORTLAND — The temporary reservation by Order in Council of 20 August, 1985 of an area of 650 square metres of land being Crown Allotment 39A, Section D, Township of Portland, Parish of Portland as a site for Health Commission purposes. — (Rs 12879).

This Order is effective from the date on which it is published in the Victoria Government Gazette.

Dated 30 March 1999

Responsible Minister:
MARIE TEHAN
Minister for Conservation
and Land Management

SHANNON DELLAMARTA
Acting Clerk of the Executive Council

Crown Land (Reserves) Act 1978

REVOCATION OF TEMPORARY RESERVATION

The Governor in Council under Section 10 of the **Crown Land (Reserves) Act 1978** revokes the following temporary reservation:

PHILLIP ISLAND — The temporary reservation under Section 5 of the **Crown Land (Reserves) Act 1978** of 27.47 hectares of land being part of Crown Allotment 120, Parish of Phillip Island transferred to the Crown by transfer No. R234894L registered in the Office of Titles on 26 February, 1991, for the propagation and management of wildlife. — (Rs 14331).

This Order is effective from the date on which it is published in the Victoria Government Gazette.

Dated 30 March 1999

Responsible Minister:
MARIE TEHAN
Minister for Conservation
and Land Management

SHANNON DELLAMARTA
Acting Clerk of the Executive Council

Crown Land (Reserves) Act 1978

REVOCATION OF TEMPORARY RESERVATIONS

The Governor in Council under Section 10 of the **Crown Land (Reserves) Act 1978** revokes the following temporary reservations:

ARARAT — The temporary reservation by Order in Council of 4 March, 1997 of an area of 47 square metres of land being Crown Allotment 21G, Section E, Township of Ararat, Parish of Ararat as a site for Public and Municipal Purposes. — (Rs 418).

BENDIGO — The temporary reservation by Order in Council of 15 May, 1973 of an area of 1796 square metres of land in Section K, At Bendigo, Parish of Sandhurst as a site for Public Purposes (Children's Playground), and the temporary reservation for the additional purpose of Public Recreation by Order in Council of 14 October, 1986. — (Rs 9742).

This Order is effective from the date on which it is published in the Victoria Government Gazette.

Dated 30 March 1999

Responsible Minister:
MARIE TEHAN
Minister for Conservation
and Land Management

SHANNON DELLAMARTA
Acting Clerk of the Executive Council

Crown Land (Reserves) Act 1978
REVOCATION OF TEMPORARY
RESERVATIONS

The Governor in Council under Section 10 of the **Crown Land (Reserves) Act 1978** revokes the following temporary reservations to the extent indicated hereunder:

GATUM GATUM — The temporary reservation by Order in Council of 1 September, 1970 of an area of 6070 square metres of land in the Parish of Gatum Gatum as a site for Public Purposes (Trigonometrical Survey Station), revoked as to part by Orders in Council of 4 September, 1984 and 11 August, 1992, so far only as the portion containing 486 square metres as indicated by hatching on plan published in the Victoria Government Gazette on 4 March, 1999 - page 561. — (Rs 9308).

MARYBOROUGH — The whole of the temporary reservation by Order in Council of 10 March, 1913 of an area of 12.917 hectares of land in Section 7B, Parish of Maryborough, (formerly in the Township of Bowenvale) as a site for Water Supply purposes. — (Rs 6563).

This Order is effective from the date on which it is published in the Victoria Government Gazette.

Dated 30 March 1999.

Responsible Minister:
MARIE TEHAN
Minister for Conservation
and Land Management

SHANNON DELLAMARTA
Acting Clerk of the Executive Council

Crown Land (Reserves) Act 1978
CROWN LANDS TEMPORARILY
RESERVED

The Governor in Council under Section 4(1) of the **Crown Land (Reserves) Act 1978** temporarily reserves the following Crown lands for the purposes mentioned:-

MUNICIPAL DISTRICT OF THE
MELBOURNE CITY COUNCIL

MELBOURNE — Public purposes (Museum purposes), 4390 square metres, more or less, being Crown Allotment 2C, Section 3, City of Melbourne, Parish of Melbourne North as indicated by hatching on plan hereunder. (M314[10]) — (Rs 37213).

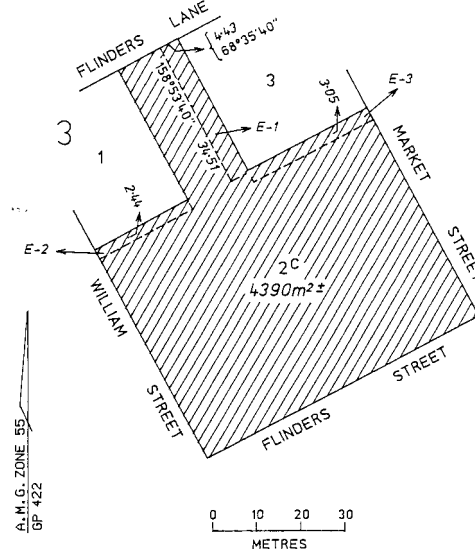

Easement: E-1 Light, air, footings and passage.
E-2 Transmission and enjoyment of light and air.
E-3 Support and Transmission and enjoyment of light and air.

MUNICIPAL DISTRICT OF THE MITCHELL SHIRE COUNCIL

REEDY CREEK — Public purposes, 7050 square metres, more or less, being Crown Allotment 4B, Section 1, Township of Reedy Creek, Parish of Clonbinane as indicated by hatching on plan hereunder. (R71[D1]) — (Rs 17051).

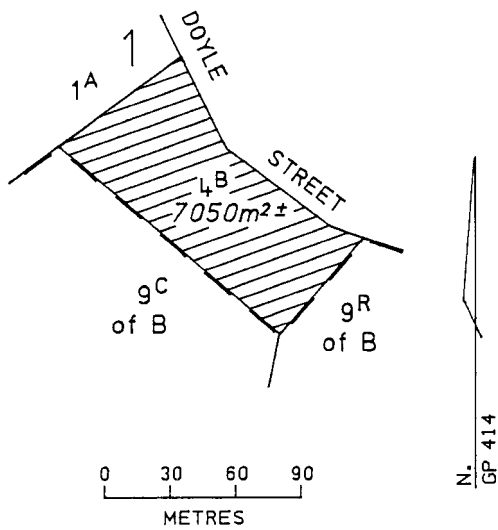

MUNICIPAL DISTRICT OF THE HOBSONS BAY CITY COUNCIL

WILLIAMSTOWN — Public purposes, 6.8 hectares, more or less, being Crown Allotment 33, Section 14, Township of Williamstown, Parish of Cut-paw-paw as indicated by hatching on plan hereunder. (W163[5&7]) — (Rs 37170).

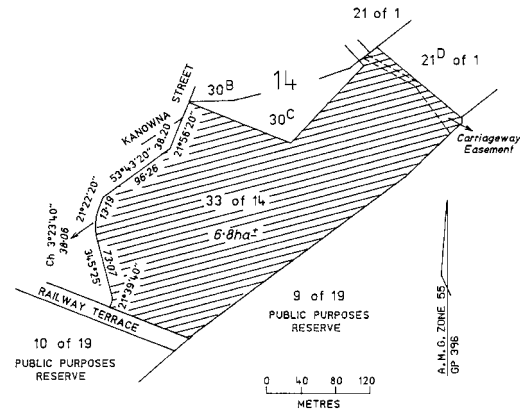

This Order is effective from the date on which it is published in the Victoria Government Gazette.

Dated 30 March 1999.

Responsible Minister:
MARIE TEHAN
Minister for Conservation
and Land Management

SHANNON DELLAMARTA
Acting Clerk of the Executive Council

MUNICIPAL DISTRICT OF THE MORNINGTON PENINSULA SHIRE COUNCIL

WANNAEUE — Public purposes, 121 square metres being Crown Allotment 5A, Section B, Parish of Wannaeue as indicated by hatching on plan hereunder. (W32[3]) — (Rs 9950).

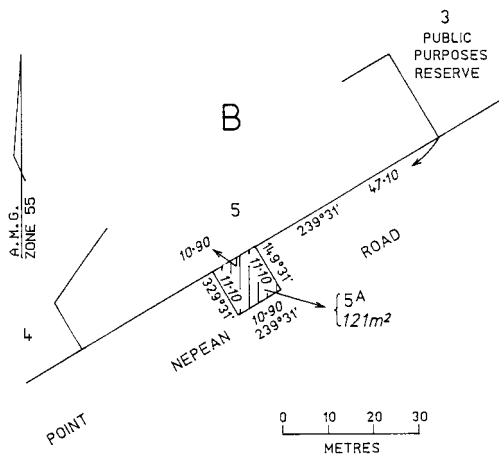

Land Act 1958

UNUSED ROADS CLOSED

The Governor in Council under Section 349 of the **Land Act 1958** and with the consents in writing of the municipalities concerned and the adjoining owners closes the following unused roads:

MUNICIPAL DISTRICT OF THE SOUTH GIPPSLAND SHIRE COUNCIL

ALLAMBEE — The road in the Parish of Allambree shown as Crown Allotment 40A on Certified Plan No. 119139 lodged in the Central Plan Office. — (15/L10-6449).

MUNICIPAL DISTRICT OF THE
BAW BAW SHIRE COUNCIL

DROUIN WEST — The road in the Parish of Drouin West shown as Crown Allotment 3A, Section D on Certified Plan No. 119177 lodged in the Central Plan Office. — (L10-6341).

MUNICIPAL DISTRICT OF THE
YARRA RANGES SHIRE COUNCIL

GRACEDALE — The road in the Parish of Gracedale shown as Crown Allotment 32C, Section 1 and Crown Allotment 163A, No Section on Certified Plan No. 119348 lodged in the Central Plan Office. — (L12/0888).

MUNICIPAL DISTRICT OF THE
NORTHERN GRAMPIANS SHIRE COUNCIL

MOKEPILLY — The roads in the Parish of Mokepilly as indicated by hatching on plan hereunder. (3140) — (02-8161).

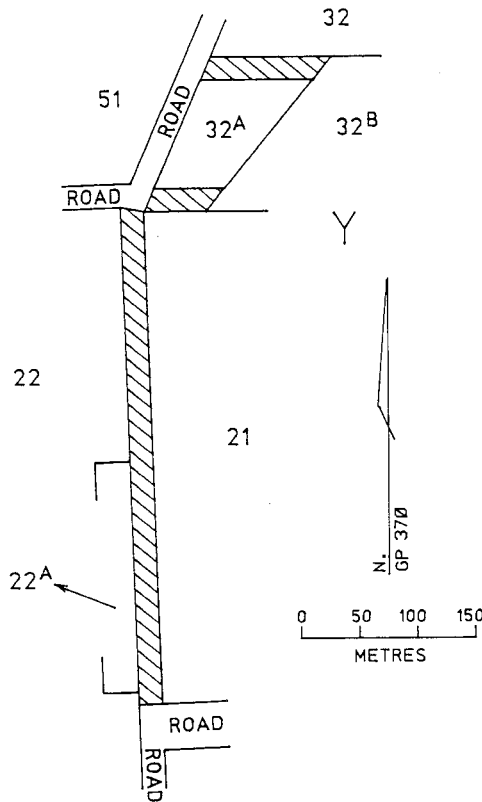

MUNICIPAL DISTRICT OF THE
MACEDON RANGES SHIRE COUNCIL

TYLDEN — The road in the Parish of Tylden as indicated by hatching on plan hereunder. (T132[2]) — (L6-8915).

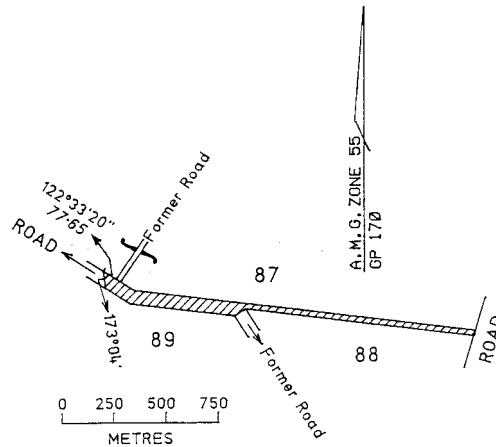

This Order is effective from the date on which it is published in the Victoria Government Gazette.

Dated 30 March 1999.

Responsible Minister:
MARIE TEHAN
Minister for Conservation
and Land Management

SHANNON DELLAMARTA
Acting Clerk of the Executive Council

**Land (Reservation and Other Matters) Act
1997**

**EXCISION FROM PERMANENT
RESERVATION**

The Governor in Council under Section 19(3) of the **Land (Reservation and Other Matters) Act 1997**, on the recommendation of the Minister for Conservation and Land Management who has received a plan of survey signed by the Surveyor-General of a portion of the land shown hatched on the plan in Schedule 11 of the Act, revokes the Order in Council specified in item 18 of Schedule 1 to the Act to the extent that it applies to the land shown on the plan of survey as specified hereunder:

SCHEDULE

DEUTGAM — Crown Allotment IV, Section C, Parish of Deutgam (area 6001 square metres) as shown on Certified Plan No. 118813 lodged in the Central Plan Office.

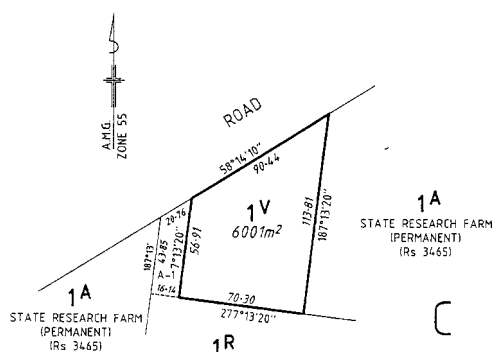

(Rs 3465)

This Order is effective from the date on which it is published in the Victoria Government Gazette.

Dated 30 March 1999.

Responsible Minister:
MARIE TEHAN
Minister for Conservation
and Land Management

SHANNON DELLAMARTA
Acting Clerk of the Executive Council

VICTORIA

State Aid To Religion Abolition Act 1871

ACT NO. 391/1871 — SECOND SCHEDULE

A statement of trusts having been submitted by the head or authorised representative of the Uniting Church in Australia under the provisions of the "Act to provide for the abolition of State Aid to Religion" for allowance by the Governor in Council, the same was allowed by him on the Thirtieth day of March, 1999, and the following is the form in which such statement of trusts has been allowed.

STATEMENT OF TRUSTS

DESCRIPTION OF LAND -

Site for Wesleyan Church purposes temporarily reserved by Order in Council of 25 November, 1861 being 1012 square metres, Township of Moyston, Parish of Moyston being Allotment 7, Section 5.

Commencing at the most northern angle of Allotment 8, Section 5; bounded thence by allotment 8 bearing 241° 30' 50.29 metres; thence by a road bearing 331° 30' 20.12 metres; thence by Allotment 6 bearing 61° 30' 50.29

metres and thence by a road bearing 151° 30' 20.12 metres to the point of commencement.

NAME OF TRUSTEES

The Uniting Church in Australia Property Trust (Victoria)

POWERS OF DISPOSITION

Such powers of disposition including powers of sale, lease or mortgage as are given to the Trustee by the **Uniting Church in Australia act No. 9021 1977** as amended.

PURPOSES TOWARDS WHICH PROCEEDS OF DISPOSITION ARE TO BE APPLIED -

To such Uniting Church in Australia purposes as shall be approved by the Synod of Victoria of the Uniting Church in Australia.

This Order is effective from the date on which it is published in the Victoria Government Gazette.

Dated 30 March 1999.

Responsible Minister:
MARIE TEHAN
Minister for Conservation
and Land Management

SHANNON DELLAMARTA
Acting Clerk of the Executive Council

VICTORIA

State Aid To Religion Abolition Act 1871

ACT NO. 391/1871 — SECOND SCHEDULE

A statement of trusts having been submitted by the head or authorized representative of the Anglican Church for the Diocese of Ballarat under the provisions of the "Act to provide for the abolition of State Aid to Religion" for allowance by the Governor in Council, the same was allowed by him on the Thirtieth day of March 1999, and the following is the form in which such statement of trusts has been allowed.

STATEMENT OF TRUSTS

DESCRIPTION OF LAND -

Site for Church of England purposes temporarily reserved by Order in Council of 19 March, 1867, being:-

1847 square metres, Township of Waubra, Parish of Ercildoun being Crown Allotment 20, Section 33.

Commencing at the north-eastern angle of Allotment 19, Section 33; bounded thence by

Hall Street bearing $100^{\circ} 23' 40''$ 20.18 metres; thence by a line bearing $190^{\circ} 55'$ 92.61 metres; thence by a road bearing $280^{\circ} 56' 20''$ 19.75 metres, and thence by Allotment 19 bearing $10^{\circ} 39'$ 92.42 metres to the point of commencement; and

3457 square metres, Township of Waubra, Parish of Ercildoun being Crown Allotment 21, Section 33.

Commencing at a point on Hall Street $100^{\circ} 23' 40''$ 20.18 metres from the north-eastern angle of Allotment 19, Section 33; bounded thence by Hall Street bearing $100^{\circ} 23' 40''$ 46.83 metres; thence by the Sunraysia Highway bearing $142^{\circ} 09'$ 25.55 metres; thence by Allotment 22 bearing $231^{\circ} 50'$ 100.84 metres, and thence by a line bearing $10^{\circ} 55'$ 92.61 metres to the point of commencement.

NAME OF TRUSTEES

The Ballarat Diocesan Trustees of the Anglican Church.

POWERS OF DISPOSITION

Power to sell, exchange, mortgage or lease.

PURPOSES TOWARDS WHICH PROCEEDS OF DISPOSITION ARE TO BE APPLIED -

Church purposes

This Order is effective from the date on which it is published in the Victoria Government Gazette.

Dated 30 March 1999

Responsible Minister:
MARIE TEHAN
Minister for Conservation
and Land Management

SHANNON DELLAMARTA
Acting Clerk of the Executive Council

**SUBORDINATE LEGISLATION ACT 1994
NOTICE OF MAKING OF STATUTORY
RULES**

Notice is hereby given under Section 17 (2) of the **Subordinate Legislation Act 1994** of the making of the following Statutory Rules:

- | | | | |
|----------------------------|---|----------------------------|---|
| 33. <i>Statutory Rule:</i> | Supreme Court
(Chapter VI
Amendment No. 1)
Rules 1999 | 38. <i>Statutory Rule:</i> | Subordinate
Legislation (Health
(Exempt Businesses)
Regulations 1989 -
Extension of
Operation)
Regulations 1999 |
| <i>Authorising Acts:</i> | Supreme Court Act
1986
Crimes Act 1958
Confiscation Act 1997 | <i>Authorising Act:</i> | Subordinate
Legislation Act 1994 |
| <i>Date of making:</i> | 25 March 1999 | <i>Date of making:</i> | 30 March 1999 |
| 34. <i>Statutory Rule:</i> | Livestock Disease
Control
(Identification)
Regulations 1999 | | |
| <i>Authorising Act:</i> | Livestock Disease
Control Act 1994 | | |
| <i>Date of making:</i> | 30 March 1999 | | |
| 35. <i>Statutory Rule:</i> | Casino Control
(Junkets and Premium
Players) Regulations
1999 | | |
| <i>Authorising Act:</i> | Casino Control Act
1991 | | |
| <i>Date of making:</i> | 30 March 1999 | | |
| 36. <i>Statutory Rule:</i> | Subordinate
Legislation
(Cemeteries
Regulations 1988 -
Extension of
Operation)
Regulations 1999 | | |
| <i>Authorising Act:</i> | Subordinate
Legislation Act 1994 | | |
| <i>Date of making:</i> | 30 March 1999 | | |
| 37. <i>Statutory Rule:</i> | Food (Forms,
Exemption and
Registration Details)
(Amendment)
Regulations 1999 | | |
| <i>Authorising Act:</i> | Food Act 1984 | | |
| <i>Date of making:</i> | 30 March 1999 | | |

**SUBORDINATE LEGISLATION ACT 1994
NOTICE THAT STATUTORY RULES ARE
OBTAINABLE**

Notice is hereby given under Section 17 (3) of the **Subordinate Legislation Act 1994** that the following Statutory Rules were first obtainable from Information Victoria, 356 Collins Street, Melbourne on the date specified:

31. *Statutory Rule:* Discharged Servicemen's Preference (Amendment) Regulations 1999

Authorising Act: Discharged Servicemen's Preference Act 1943

Date first obtainable: 1 April 1999

Code A

32. *Statutory Rule:* Adoption (Amendment) Regulations 1999

Authorising Act: Adoption Act 1984

Date first obtainable: 1 April 1999

Code A

33. *Statutory Rule:* Supreme Court (Chapter VI Amendment No. 1) Rules 1999

Authorising Acts: Supreme Court Act 1986
Crimes Act 1958
Confiscation Act 1997

Date first obtainable: 1 April 1999

Code D

Retail price will vary according to the number of pages in each special or periodical gazette. The table below sets out the prices that apply

<i>Price Code</i>	<i>No. of Pages (Including cover and blank pages)</i>	<i>Price</i>
A	1-16	\$2.90
B	17-32	\$4.30
C	33-48	\$5.90
D	49-96	\$9.15
E	97-144	\$11.85
F	145-192	\$14.00
G	193-240	\$16.15
H	241-288	\$17.20
I	289-352	\$19.35
J	353-416	\$22.60
K	417-480	\$25.80
L	481-544	\$30.10
M	545-608	\$34.40
N	609-672	\$38.70
O	673-736	\$43.00
P	737-800	\$47.30

ADVERTISERS PLEASE NOTE

As from 1 April 1999

The last Special Gazette was No. 47 dated 31 March 1999

The last Periodical Gazette was No. 1 dated 2 June 1998

CONTENTS

	Page
Estates of Deceased Persons	756
Government and Outer Budget Sector	
Agencies Notices	764
Orders in Council—	786
Acts — Fisheries; Melbourne City Link; Land; Crown Land (Reserves); Land (Reservations and Other Matters); State Aid to Religion Abolition	
Private Advertisements	756
Proclamations	763

The Victoria Government Gazette is published by The Craftsman Press Pty. Ltd. with the authority of the Government Printer for the State of Victoria
© State of Victoria 1999

ISSN 0819-5471

This publication is copyright. No parts may be reproduced by any process except in accordance with the provisions of the Copyright Act.

Products and services advertised in this publication are not endorsed by The Craftsman Press Pty. Ltd. or the State of Victoria and neither of them accepts any responsibility for the content or the quality of reproduction. The Craftsman Press Pty. Ltd. reserves the right to reject any advertising material it considers unsuitable for government publication.

Address all inquiries to the Government Printer for the State of Victoria
1 Macarthur Street
Melbourne 3002 Victoria Australia

RETAIL SALES

Information Victoria Bookshop
356 Collins Street Melbourne 3000.
Telephone enquiries 1300 366 356

City Graphics
2nd Floor, 4 Bank Place
Melbourne 3000
Telephone enquiries (03) 9600 0977

Recommended Retail Price \$1.70

Government and Outer Budget Sector Agencies please note:
STYLE REQUIREMENTS.

To ensure that material received can be reproduced, and that errors are minimised, the following guidelines are to be observed when submitting material by fax.

Fax resolution:

Material sent by fax should be transmitted using Fine Resolution (200 dots per inch by 200 dpi).

Font size:

Use 12 point (10 pitch) or larger.

Font Style:

Clear plain font styles, such as Helvetica, should be used.

Graphics:

Line drawings should be transmitted as large as possible to ensure clarity. Drawings up to A4 size sent by fax using Fine Resolution provide a good quality for reproduction.

Avoid:

Italics, underlining and full justification.

Ensure document is square when sending as documents that are sent skewed are difficult to read and process.