



Victoria Government Gazette

No. G 17 Thursday 29 April 1999

GENERAL

GENERAL AND PERIODICAL GAZETTE

Copy to: Gazette Officer
The Craftsman Press Pty. Ltd.
125 Highbury Road,
Burwood Vic 3125
Telephone: (03) 9926 1233
Facsimile: (03) 9926 1292
DX: 32510 Burwood
Email: gazette@craftpress.com.au

Advertising Rates and Payment

Private Notices

Payment must be received in advance with advertisement details.

30 cents per word - Full page \$180.00.

Additional costs must be included in prepayment if a copy of the gazette is required. Copy Prices - Page \$1.50 - Gazette \$3.20 Certified copy of Gazette \$3.50. (all prices include Postage). **Cheques should be made payable to The Craftsman Press Pty. Ltd.**

Government and Outer Budget Sector Agencies Notices

Not required to pre-pay.

Advertisements may be faxed or sent via email with a cover sheet, marked to the attention of the Gazette Officer.

Floppy Disks (Mac & PC) can also be accepted.

Costs can be calculated on the following basis:

Per Line	Typeset
Single column	\$1.55
Double column	\$3.10
Full Page	\$64.80

The Craftsman Press is pleased to offer a series of discounts from the typesetting costs.

1. Copy supplied on disk.
2. Copy supplied via email.
3. Artwork for forms and other material which require exact reproduction.

1. Copy supplied on disk.

Where a disk is supplied and there is minimum alteration required, **30% off.**

Where a disk is supplied requiring extraneous matter stripped out and styles applied, **20% off.**

2. Copy supplied via email.

Where a notice is sent via email and there is minimum alteration required, **25% off.**

Where email is supplied requiring extraneous matter stripped out and styles applied, **15% off.**

3. Artwork for forms and other material which requires exact reproduction.

Scanning and sizing of artwork for forms, to be reproduced in page format, **35% off.**

Copy Deadline for General Gazette

9.30 a.m. Monday - (Private Notices)

9.30 a.m. Tuesday - (Government and Outer Budget Sector Agencies Notices)

Advertisers should note:

- Late copy received at The Craftsman Press Pty. Ltd. after deadlines will be placed in the following issue of VGG, irrespective of any date/s mentioned in the copy (unless otherwise advised).
- Proofs will be supplied only when requested or at the direction of the Gazette Officer.
- No additions or amendments to material for publications will be accepted by telephone.
- Orders in Council may be lodged prior to receiving assent with the Governor's or Clerk's signature. They will only be published once approved and signed.
- Government and Outer Budget Sector Agencies please note: *See style requirements on back page.*

SPECIAL GAZETTES

Copy to: Gazette Officer
The Craftsman Press Pty. Ltd.
125 Highbury Road,
Burwood Vic 3125
Telephone: (03) 9926 1233
Facsimile: (03) 9926 1292
Email: gazette@craftpress.com.au

Advertising Rates and Payment

Private Notices

Full Page \$360.00

Payment must be received in advance with notice details.

Government and Outer Budget Sector Agencies Notices

Full Page	Typeset
	\$87.50

Note:

The after hours number for Special Gazettes is:

Telephone: 0419 327 321

SUBSCRIPTIONS AND RETAIL SALES

Copies of the Victoria Government Gazette can be purchased from The Craftsman Press Pty. Ltd. by subscription.

The Victoria Government Gazette

General and Special - \$170.00 each year

General, Special and Periodical - \$227.00 each year

Periodical - \$113.00 each year

Subscriptions are payable in advance and accepted for a period of one year. All subscriptions are on a firm basis and refunds will not be given.

All payments should be made payable to The Craftsman Press Pty. Ltd.

Subscription enquiries:

The Craftsman Press Pty. Ltd.

125 Highbury Road, Burwood Vic 3125

Telephone: (03) 9926 1233

INDEX TO PRIVATE ADVERTISERS

A

Aitken Walker Strachan957
 Amerenas957

B

Birch Ross & Barlow958
 Brendan H. Hardiman & Associates958

D

Devenish & Co.958

E

E.P. Johnson & Davis958

G

Garden & Green958
 Gray Friend & Long958

H

Holding Redlich958

J

John Matthies & Co.959

K

Kenneth E. Toop959

L

Littleton Hackford959
 Lynch & Macdonald959
 Lyttletons959

M

McPherson & Kelley960
 Mason Sier Turnbull960

N

National Mutual Trustees Limited960

P

Pearce Webster Dugdales960
 Paul McGuinness & Associates Pty960
 Peter Joseph Callahan960
 Peter J. Walsh Caroll Kiernan & Forrest ...961
 Phillips & Wilkins961
 Purves Clarke Richards961

R

Roberts & Roberts Partners961

S

Sam Stidston961

W

Wisewoulds961

Y

Yuncken & Yuncken961

PRIVATE ADVERTISEMENTS

DISSOLUTION OF PARTNERSHIP

Notice is hereby given that the partnership previously subsisting between Irene Margaret McGregor and Murray Gordan McGregor carrying on business as farmers at Stawell under the name of "Balquhider Partnership" has been dissolved by mutual consent as from 1 April 1999. All debts due to and owing by the said firm will be received and paid respectively by Murray Gordan McGregor who will continue to carry on the said business.

DISSOLUTION OF PARTNERSHIP

Notice is given that the partnership previously subsisting between G. M. Chiropractic Services Pty Ltd, A.C.N. 074 023 082, and David Andrew Hendrey carrying on the business of chiropractors under the registered business name of "Mt Eliza Chiropractic Clinic" has been dissolved by agreement effective as at 1 April 1999.

G. M. Chiropractic Services Pty Ltd, A.C.N. 074 023 082, through its managing director, Glenn Maginness, continues to trade under the registered business name "Mt Eliza Chiropractic Clinic".

EBSWORTH & EBSWORTH, solicitors
565 Bourke Street, Melbourne.

DISSOLUTION OF PARTNERSHIP

Notice is hereby given that the partnership previously subsisting between King Village Pty Ltd and Southern Basketball Association Inc. carrying on business as a cafe and take away food business at the Sandringham Leisure Centre in Tulip Street, Sandringham under the name or style of "King Club Cafe" has been dissolved as from 16 April 1999 after which date the business will be conducted solely by King Village Pty Ltd.

BURKE & ASSOCIATES, solicitors
1127 High Street, Armadale.

DISSOLUTION OF PARTNERSHIP

Notice is hereby given that the partnership previously subsisting between Gwenyth Lloyd McIntyre, Janet Elizabeth Lowing and Kenneth Andrew McIntyre as trustees of the estate of Henry James McIntyre, Gwenyth Lloyd McIntyre and Janet Elizabeth Lowing carrying on business as farmers at Willaura under the

name of "Karmala Partnership" has been dissolved by mutual consent as from the 30 June 1998. All debts due to and owing by the said firm will be received and paid respectively by Gwenyth Lloyd McIntyre and Janet Elizabeth Lowing who will continue to carry on the said business under the name of Karmala Partnership.

KERRI LYNN STEPANCIC, late of 212 Progress Road, Eltham, deceased. Creditors, next-of-kin and others having claims in respect of the estate of the deceased, who died on 8 June 1997 are required by the personal representative, ANZ Executors & Trustee Company Limited of 530 Collins Street, Melbourne, to send particulars to them care of the undermentioned solicitors by 7 July 1999 after which date the personal representative may convey or distribute the assets having regard only to the claims of which they then have notice.

AITKEN WALKER & STRACHAN,
solicitors,
114 William Street, Melbourne 3000.

FRANK STEPANCIC, also known as Franco Stepancic, late of 212 Progress Road, Eltham, deceased. Creditors, next-of-kin and others having claims in respect of the estate of the deceased, who died on 8 June 1997 are required by the personal representative, ANZ Executors & Trustee Company Limited of 530 Collins Street, Melbourne, to send particulars to them care of the undermentioned solicitors by 7 July 1999 after which date the personal representative may convey or distribute the assets having regard only to the claims of which they then have notice.

AITKEN WALKER & STRACHAN,
solicitors,
114 William Street, Melbourne 3000.

In the estate of EMMA JOSEPHINE MEYERS, late of 5A Monaco Street, Parkdale, in the State of Victoria, retired sales assistant, deceased. Creditors, next-of-kin and all other persons having claims against the estate of the said deceased, who died on 12 July 1998 are required by Michael John Meyers of 1/16 Murrumbeena Road, Murrumbeena, in the State of Victoria, company director, the executor of the estate of the said deceased, to send

particulars of such claims to him care of the undermentioned solicitors on or before 29 June 1999 after which date he will distribute the assets having regard only to the claims of which he then has notice.

AMERENAS, solicitors,
5/24 Bay Road, Sandringham, Vic. 3191.

Re: Estate of FLORENCE MARY MASON, deceased, formerly of Tarwin Lower, but late of Cranhaven Lodge, Lyall Street, Cranbourne, Victoria, home duties. Creditors, next-of-kin and others having claims in respect of the estate of the deceased, who died on 18 October 1998 are required by the trustee of National Mutual Trustees Limited, A.C.N. 004 029 841, in the will called National Trustees Executors and Agency Company Limited of 65 Southbank Boulevard, Southbank, Victoria, to send particulars to the trustee by 29 June 1999 after which date the trustee may convey or distribute the assets having regard only to the claims of which the trustee has notice.

BIRCH ROSS & BARLOW, solicitors,
45a Bair Street, Leongatha.

Creditors, next-of-kin and others having claims in respect of the estate of HERTA BORNER, late of 92 Gertonia Avenue, Boronia, Victoria, nursing instructress, deceased, who died on 23 December 1998 are to send particulars of their claims to the executors, Jurgen Ingomar Werner Voelker, Christopher Gernot Amos-Voelker and Sylvia Ann Voelker, care of the undermentioned solicitors by 27 June 1999 after which date the executors will convey or distribute the assets having regard only to the claims of which they then have notice.

BRENDAN H. HARDIMAN & ASSOCIATES,
solicitors,
108 Railway Avenue, Ringwood East.

Creditors, next-of-kin and others having claims in respect of the estate of CYRIL WILLIAM EVERETT, late of 7 Willow Street, Box Hill, Victoria, pensioner, deceased, who died on 21 January 1999, are required by the executrix, Dianne Lorraine O'Leary of 4 Cole Court, North Box Hill, Victoria, to send particulars of their claims to the undermentioned solicitors by 8 July 1999 after which date the executrix may convey or distribute the assets having regard only to the claims of which she then has notice.

DEVENISH & CO., solicitors,
23 Ringwood Street, Ringwood, Victoria 3134.

Creditors, next-of-kin and others having claims in respect of the estate of RAILTON LAIDLAW, late of 220 Middleborough Road, Blackburn South, but formerly of 6/3 Newlands Road, Coburg, Victoria, retired accountant, deceased, who died on 9 December 1998 are to send particulars of their claims to the executors care of the undermentioned solicitors by 30 June 1999 after which date the executors will distribute the assets having regard only to the claims of which the executors then have notice.

E. P. JOHNSON & DAVIES, solicitors,
30 Collins Street, Melbourne 3000.

STANLEY LINDSAY SHARAM, late of 68 McCrae Street, Swan Hill, Victoria, retired farmer, deceased. Creditors, next-of-kin and others having claims in respect of the estate of the deceased, who died on 12 February 1999 are required by the trustees, Alison Lorraine Stedman and Cynthia Josephine Dunstan, to send particulars to them care of the undermentioned solicitors by 16 June 1999 after which date the trustees may convey or distribute the assets having regard only to the claims of which they then have notice.

GARDEN & GREEN, lawyers,
4 McCallum Street, Swan Hill.

FRANCES LAUREL VICTORIA BERLOWITZ, late of 14/30-32 Denbigh Road, Armadale, investor, deceased. Creditors, next-of-kin and others having claims in respect of the estate of the deceased, who died on 29 December 1998 are required by the trustee, Margaret Lillie O'Donnell to send particulars of their claims to her care of the undersigned solicitors by 29 June 1999 after which date the trustee may convey or distribute the assets having regard only to the claims of which she then has notice.

GRAY FRIEND & LONG, solicitors,
70 Queen Street, Warragul 3820.

Creditors, next-of-kin and all other persons having claims against the estate of GRETE BLOCH (also known as Greta Bloch) late of 518 Dandenong Road, North Caulfield, Victoria, widow, deceased, who died on 2 January 1999 are to send particulars of their claims to the executor of the estate, Harry Martin Bloch, care of the undermentioned solicitors by 28 June 1999, after which date the

executor will convey and distribute the assets having regard only to the claims of which the executor then has notice.

HOLDING REDLICH, solicitors,
350 William Street, Melbourne.

Creditors, next-of-kin and all other persons having claims in respect of the estate of ANTONIO D'ANGELO, late of 15 Laughlin Avenue, Nunawading, Victoria, pensioner, deceased, who died on 26 February 1999, are to send particulars of their claims to the executors of the estate, Pasqualino D'Angelo and Sergio D'Angelo, care of the undermentioned solicitors by 30 June 1999 after which date the executors will convey and distribute the assets having regard only to the claims of which the executors then have notice.

HOLDING REDLICH, solicitors,
350 William Street, Melbourne.

Creditors, next-of-kin and others having claims in respect of the estate of LORRAINE BARBARA GREEN, late of 27 Brooke Street, Eaglemont, Victoria, home duties, deceased, who died on 31 August 1998 are required by the executors, Lindsay William Gibson of 5 Percy Street, Black Rock, Victoria, gentleman and John Glyn Matthies of 416 Collins Street, Melbourne, Victoria, solicitor, to send particulars of their claims to the solicitors of the executors, John Matthies & Co., at its address of 6th Floor, 416 Collins Street, Melbourne by 1 July 1999 after which date the executors may convey or distribute the assets having regard only to the claims of which they then have notice.

JOHN MATTHIES & CO.,
legal practitioners for the applicant,
6th Floor, 416 Collins Street, Melbourne 3000.

Creditors, next-of-kin and others having claims in respect of the estate of ALLAN EDGAR MEAKER, late of 12 Ross Street, Nagambie, Victoria, retired, deceased, who died on 21 January 1999, are required by Trevor Graeme Meaker of 640 Pascoe Vale Road, Oak Park, the executor of the will of the deceased, to send particulars of their claims to the said Trevor Graeme Meaker, care of the undermentioned solicitor by 20 July 1999 after

which date the said Trevor Graeme Meaker will distribute the assets of the estate having regard only to the claims of which he then has notice.

KENNETH E. TOOP, solicitor,
9 Barrington Avenue, Kew.

Creditors, next-of-kin and others having claims in respect of the estate of JOHN WILLIAM SMITH, late of R.S.L. War Veteran's Home, Overport Road, Frankston, Victoria, retired, gentleman, deceased, who died on 3 April 1999, are to send their claims to the trustees, Carole Anne Little of 18 Parkland Court, Keysborough, Victoria and Denise Leslie Rich of Reynolds Road, Swan Reach, Victoria, care of the below mentioned solicitors by 30 June 1999 after which date they will distribute the assets of the deceased having regard only to the claims of which they then have notice.

LITTLETON HACKFORD, solicitors,
"Law Chambers",
115 Hotham Street, Traralgon, Vic. 3844.

Creditors, next-of-kin and others having claims in respect of the estate of LEONARD ARTHUR ELLIOTT, late of 42 Stewart Terrace, Macleod, Victoria, driver, deceased, who died on 29 December 1998 are to send particulars of their claims to Raymond Morrow, in the care of Lynch & MacDonald by 27 June 1999 after which date they will distribute the assets having regard only to the claims of which they then have notice.

LYNCH & MACDONALD, solicitors,
412 Collins Street, Melbourne, Vic. 3000.

JEFFREY MAX FERGUSON, late of 46 Langridge Street, Middle Park, Victoria, accountant, deceased. Creditors, next-of-kin and others having claims in respect of the estate of the deceased, who died on 9 January 1999 are required by the executors, Judith Margaret Fergusson, Suzanne Louise Fergusson and John Gavin Maxwell Fergusson, to send particulars to them care of the undermentioned solicitors by a date not later than two months from the date of publication hereof, after which date the executors may convey or distribute the assets having regard only to the claims of which they then have notice.

LYTTLETONS, solicitors,
53 Marcus Road, Dingley.

WILLIAM LINDSAY ROBERTS of 11 Rex Court, Noble Park, gentleman, deceased. Creditors, next-of-kin and others having claims in respect of the estate of the deceased, who died on 29 April 1998 are required by Bruce John Fletcher of 48 Orchard Street, Brighton, solicitor, the executor of the will of the said deceased to send particulars to him in the care of the undermentioned solicitors by 29 June 1999 after which date the said executor may convey or distribute the assets having regard only to the claims of which he then has notice.

McPHERSON & KELLEY, solicitors,
40-42 Scott Street, Dandenong.

IVY MARGARET RONALDSON, late of Surrey Hills Private Nursing Home, 16-18 Florence Road, Surrey Hills, Victoria, retired, deceased. Creditors, next-of-kin and others having claims in respect of the estate of the deceased, who died on 6 February 1999 are required by the trustees, Eleanor Margaret McCoy, in the will called Eleanor Margaret Ronaldson of 26 Alvie Road, Mount Waverley, Victoria, retired and Neil Ross Ronaldson of 15 Omeo Parade, Warranwood, Victoria, accountant, to send particulars to the trustees by 28 June 1999 after which date the trustees may convey or distribute the assets having regard only to the claims of which the trustees then have notice.

MASON SIER TURNBULL, solicitors,
5 Hamilton Place, Mount Waverley 3149.

PAULINE ANNE BROWNE, late of Unit 3-4 "Domain Park", 193 Domain Road, South Yarra, widow. Creditors, next-of-kin and others having claims in respect of the estate of the deceased, who died on 11 March 1999 are required by National Mutual Trustees Limited of 65 Southbank Boulevard, Southbank, Victoria 3006, the applicant for a grant of probate, to send particulars to it by 2 July 1999 after which date the applicant for a grant of probate may convey or distribute the assets having regard only to the claims of which it then has notice.

DUNCAN CLARK ROSS, late of Meadowvale Retirement Village, Eagle Drive, Pakenham, retired. Creditors, next-of-kin and others having claims in respect of the estate of the deceased, who died on 17 February 1999 are required by National Mutual Trustees Limited of 65 Southbank Boulevard, Southbank, Victoria

3006, the applicant for a grant of probate, to send particulars to it by 2 July 1999 after which date the applicant for a grant of probate may convey or distribute the assets having regard only to the claims of which it then has notice.

VICTORIA EMILY FOX, late of 5 Byron Street, Canterbury, widow, deceased. Creditors, next-of-kin and others having claims in respect of the estate of the deceased, who died on 19 December 1998 are required by the trustee, Equity Trustees Limited of 472 Bourke Street, Melbourne, to send particulars to the trustee by 28 June 1999 after which date the trustee may convey or distribute the assets having regard only to the claims of which the trustee has notice.

PEARCE WEBSTER DUGDALES, solicitors,
379 Collins Street, Melbourne.

JACK HAMMILL LANE, late of 33 Wattle Road, Hawthorn, Victoria, retired, deceased. Creditors, next-of-kin and others having claims in respect of the estate of the deceased, who died on 18 December 1998 are required to send particulars of their claims to the trustees, Keith Raymond and Dorothy Leona Hennessy, care of the undermentioned solicitors by 27 June 1999 after which date the trustees or personal representatives or applicant for grant of administration may convey or distribute the assets having regard only to the claims of which they then have notice.

PAUL McGUINNESS & ASSOCIATES PTY.,
solicitors,
3 Eighth Avenue, Rosebud 3939.
Tel. (03) 5986 6999.

Creditors, next-of-kin and others having claims against the estate of BRIAN ROBERT O'MEARA, late of 15 Highfield Avenue, Mount Clear, enquiry agent, deceased, who died on 30 January 1999 are hereby required by the executor, Peter Joseph Callahan, to send particulars of such claims to him at the undermentioned address on or before 15 July 1999 after which date the executor will transfer and convey the assets of the deceased having regard only to the claims of which he shall then have had notice.

PETER JOSEPH CALLAHAN,
7 Lawrence Street, Eaglemont 3084.

Creditors, next-of-kin and others having claims in respect of the estate of ANASTASIA MAUD BOURKE, also known as Anastasia Maud Frances Bourke, late of St. Catherine's Hostel, 1 Clayton Road, Balwyn, Victoria, widow, deceased, who died on 8 March 1999 are requested to send particulars of their claims to the executor, Terence William Martin, care of the undermentioned solicitors by 30 June 1999 after which date the executor will distribute the assets having regard only to the claims of which he then has notice.

PETER J. WALSH CARROLL KIERNAN & FORREST, solicitors,
83 William Street, Melbourne.

ROBERT WILLIAM MUNDY, late of Elgar Private Nursing Home, 366 Elgar Road, Box Hill, Victoria, gentleman, deceased. Creditors, next-of-kin and others having claims in respect of the estate of the deceased, who died on 12 March 1999, are required by the trustees, Lawrence Barrymore Wilkins of 823 High Street, Thornbury, Victoria, solicitor and Grant Kenton MacKenzie of 823 High Street, Thornbury, Victoria, solicitor, to send particulars to the trustees by 30 June 1999 after which date the trustees may convey or distribute the assets having regard only to the claims of which the trustees then have notice.

PHILLIPS & WILKINS, solicitors,,
823 High Street, Thornbury.

Creditors, next-of-kin or others having claims in respect of the estate of KATHLEEN BETTY COCKERELL, late of 263 Noble Street, Newtown, Victoria, widow, deceased, who died on 15 February 1999 are to send particulars of their claims to the executor care of the undermentioned solicitors by 24 June 1999 after which date the executor will distribute the assets having regard only to the claims of which the executor then has notice.

PURVES CLARKE RICHARDS, solicitors,
121 William Street, Melbourne.

IRIS BERYL ANDERSON, late of George Vowell Centre, Cobb Road, Mount Eliza, but formerly of Unit 1, 52 Queen Street, Mornington, widow, deceased. Creditors, next-of-kin or others having claims in respect of the estate of the deceased, who died on 19 January 1999, are required by the trustee, Russell Walter Gazzard of Unit 1, 44 Beleura Hill Road, Mornington, Victoria, retired dentist, to send particulars to

the trustee by 30 June 1999 after which date the trustee may convey or distribute the assets having regard only to the claims of which the trustee then has notice.

ROBERTS & ROBERTS PARTNERS,
216 Main Street, Mornington.

WINIFRED MAY ELLIOTT, late of Unit 168, 130 McLeod Road, Carrum, Victoria, home duties, deceased. Creditors, next-of-kin and others having claims in respect of the estate of the deceased, who died on 18 January 1999, are required by the trustee, Roderick McDonald Elliott Cumming of Flat 15, 6 Westbury Street, St. Kilda, Victoria, to send particulars to him by 3 July 1999 after which date the trustee may convey or distribute the assets, having regard only to the claims of which he then has notice.

SAM STIDSTON & CO., solicitors,
307 Main Street, Mornington.

ENID LORRAINE POWELL, formerly of Flat 14, 32 Berkeley Street, Hawthorn, but late of 27 Wattle Road, Hawthorn, Victoria, gentlewoman, deceased. Creditors, next-of-kin and others having claims in respect of the estate of the deceased, who died on 20 December 1998 are required by the executors, Harley Robert Powell of 10 Dempster Avenue, North Balwyn and Ian Andrew Ness of 459 Collins Street, Melbourne, to send particulars to the executors by 27 June 1999 after which date the executors intend to convey or distribute the assets of the estate having regard only to the claims of which the executors may have notice.

WISEWOULDS, solicitors,
459 Collins Street, Melbourne.

DAVID FRANCIS PATRICK BROWN, also known as David Francis Brown, late of 6 Morrison Crescent, Doncaster, retired manufacturers agent, deceased. Creditors, next-of-kin and others having claims in respect of the estate of the deceased, who died on 28 October 1998 are required by the trustee, Leo John Brown of 6 Morrison Crescent, Doncaster, Victoria, to send particulars to the trustee by 28 June 1999 after which date the trustee may convey or distribute the assets having regard only to the claims of which the trustee then has notice.

YUNCKEN & YUNCKEN, solicitors,
Level 9, 455 Bourke Street, Melbourne.

In the County Court of the State of Victoria
SALE BY THE SHERIFF

On 3 June 1999 at 2.30 p.m. at the Sheriff's Office, 8-20 King Street, Oakleigh, (unless process be stayed or satisfied).

All the estate and interest (if any) of Mike Dinh Dat Nguyen of One Cook Avenue, Kealba as shown on Certificate of Title as Mike Dat Dinh Nguyen, joint proprietor with Shanice Yen Dinh of an estate in fee simple in the land described on Certificate of Title Volume 9592 Folio 436 which is vacant land known as 103 Rowan Drive, Kealba.

Registered Mortgage No. V238589A and Caveat Nos V631929Q and V631930Q affect the said estate and interest.

Terms - Cash only.

CW-98-013073-3

Dated 29 April 1999.

S. BLOXIDGE
Sheriff's Office

In the County Court of the State of Victoria
SALE BY THE SHERIFF

On 3 June 1999 at 2.30 p.m. at the Sheriff's Office, 8-20 King Street, Oakleigh, (unless process be stayed or satisfied).

All the estate and interest (if any) of Stan Knihnicky of 8 Bamba Court, West Sunshine as shown on Certificate of Title as Stanislaus Knihnicky, joint proprietor with Ursula Knihnicky of an estate in fee simple in the land described on Certificate of Title Volume 8940 Folio 416 upon which is erected a dwelling known as 8 Bamba Court, West Sunshine.

Registered Mortgage Nos F337518, L71620F affect the said estate and interest.

Terms - Cash only.

CW-98-012245-8.

Dated 29 April 1999.

S. BLOXIDGE
Sheriff's Office

In the Supreme Court of the State of Victoria
SALE BY THE SHERIFF

On 3 June 1999 at 11.00 a.m. at the Sheriff's Office, 107 Baxter Street, Bendigo, (unless process be stayed or satisfied).

All the estate and interest (if any) of MKZ Holdings Pty Ltd. of Lot One Gleasons Road, Lyonville, proprietor of an estate in fee simple in the land described on Certificate of Title Volume 10365 Folio 842 which is vacant land.

The property can be located by travelling from Melbourne along the Western Freeway to the Ballan-Daylesford Road exit, head north back over the Freeway continue to the Township of Daylesford. The property is located in Daylesford and is known as Lot 13 Strebor Drive, Daylesford.

Terms - Cash only.

SW-98-011593-8.

Dated 29 April 1999.

S. BLOXIDGE
Sheriff's Office

In the Supreme Court of the State of Victoria
SALE BY THE SHERIFF

On 3 June 1999 at 2.30 p.m. at the Sheriff's Office, 8-20 King Street, Oakleigh, (unless process be stayed or satisfied).

All the estate and interest (if any) of Van Thanh Nguyen and Ba Thi Le of One Maryland Close, Thomastown as shown on Certificate of Title as Thanh Van Nguyen and Ba Thi Le, joint proprietors of an estate in fee simple in the land described on Certificate of Title Volume 9154 Folio 201 upon which is erected a residence known as One Maryland Close, Thomastown.

Registered Mortgage Nos. S352031U, T168810Y and Caveat No. T143262B and the Covenant contained in Transfer H 454745 affect the said estate and interest.

Terms - Cash only.

SW-98-015419-5.

Dated 29 April 1999.

S. BLOXIDGE
Sheriff's Office

Unclaimed Moneys Act 1962

Register of Unclaimed Moneys held by the —

<i>Name of Owner on Books and Last Known Address</i>	<i>Total Amount Due to Owner</i>	<i>Description Of Unclaimed Money</i>	<i>Date when Amount first became Payable</i>
BERKLEE LIMITED			
	\$		
James Godfrey Rebgetz, Unit 6, Fairbank Crescent, Dalrymple Villa Fraser Street, Charters Towers, Qld	105.00	Cheque	10.11.97

99016

CONTACT: EDWARD VAN BERKEL PHONE: (03) 5338 1110.

Unclaimed Moneys Act 1962

Register of Unclaimed Moneys held by the —

<i>Name of Owner on Books and Last Known Address</i>	<i>Total Amount Due to Owner</i>	<i>Description Of Unclaimed Money</i>	<i>Date when Amount first became Payable</i>
HOUSING GUARANTEE FUND LTD			
	\$		
C. & J. Simonic, 1/15-17 Jobson Street, Williamstown	300.00	Cheque	19/01/98
N. V. & J. E. Marr, 3 Osborne Close, Williamstown	103.00	"	20/10/97

99036

CONTACT: GERALD SULLIVAN PHONE: (03) 9660 6296.

Unclaimed Moneys Act 1962

Register of Unclaimed Moneys held by the —

<i>Name of Owner on Books and Last Known Address</i>	<i>Total Amount Due to Owner</i>	<i>Description Of Unclaimed Money</i>	<i>Date when Amount first became Payable</i>
EASTERN ENERGY LIMITED			
	\$		
Metropolis Corp Pty Ltd, P.O. Box 202, Lilydale 3140	1,998.00	Cheque	23/08/96
I.I.R P/L, P.O. Box 2133, North Sydney, NSW	1,095.00	"	29/12/95

Goodyear Beaconsfield, 26 Princes Highway, Beaconsfield	970.00	''	30/01/96
Mrs N. Bygate, 1174 Main Road	919.50	''	03/06/96
A.C.M., G.P.O. Box 1469N, Melbourne 3001	825.00	''	13/11/95
CC Recors Pty Ltd,			
Sh3-025 Greensborough Plaza, Greensborough	633.70	''	28/02/98
Yamamoto, Tomoko, 737 Mountain Hwy, Bayswater	521.10	''	31/07/97
Riverside Apartments, 474 Flinders Street, Melbourne	504.13	''	15/02/96
Millers Fashion Club P/L, G51 Eastland, Ringwood	503.38	''	31/12/97
Timothy Donald, 55 Sasses Avenue	500.00	''	04/06/96
Mr Graham Smith, C/o Eastern Energy, P.O. Box 202, 3140	483.00	''	31/01/96
Zindik Pty Ltd, 225 Main Street, Bairnsdale	460.40	''	31/01/98
Korszun, Doris, 518 Silvan Road, Monbulk	458.15	''	31/12/97
I.C.A. Australia Operations, 59 Mc Leod Street, Bairnsdale	455.95	''	28/02/98
E.J. & S.J. Pty Ltd, 21 Jenkins Drive	417.06	''	18/07/96
Farm Fodder Trees, P.O. Box 77, Olinda 3788	406.24	''	28/05/96
Eco Bedding, 5 Cliveden Court, Thomastown	385.63	''	31/08/97
Kouis, Steve, 15 Charnfield Court, Thomastown	361.27	''	28/02/98
Yarra Valley Newspaper P/L, 18 Main Road, Monbulk	332.35	''	31/08/97
Michael J. Smith, Fcty 161 Queen Street, Warragul	331.10	''	31/01/98
Dawson, Michael J., 323 White Road, Wonthaggi North	280.31	''	28/03/97
S.W. & N.K., Sharma, Shop 5, 159 Boronia Road, Boronia	277.96	''	28/02/98
Salavation Army Gipps Care, Fl1 7 Henry St, West Wonthaggi	270.30	''	''
Warradoo Quarry, P.O. Box 119, Woori Yallock 3139	264.63	''	30/09/96
Australian Quality Control, P.O. Box 298, St Leonards 2065	250.00	''	01/12/95
Grant W. Carroll, Rmb 4262, Buxtons Road, Stradbroke	221.23	''	31/08/97
Alexander Georgieff, C/o 10 Mercil Road, Alphington	208.58	''	29/12/95
Ben Wong, 17 Yiannis Court	204.60	''	26/07/96
Tandy Electronics, Shop 38D,			
Greensborough Plaza, 25 Main Street, Greensborough	203.25	''	30/11/95
Berracarry P/L, 8 Hereford Road, Mt Evelyn	200.00	''	31/01/98
D. W. & T. M. Oddy, 168 Main Street, Bairnsdale	196.70	''	27/08/96
Kenneth Fay, 29 Spencer Street	195.08	''	22/10/96
Inchape NRG Pty Ltd., Locked Bag 2500, Brookvale, NSW	194.16	''	25/01/96
Sharon Maree Comer, 208 Main Street, Bairnsdale	187.59	''	30/09/97
Austotel Trading Pty Ltd, 87 May Street	185.50	''	12/07/96
Kim M. Bowman, The Cellar, 2A Barnard Street, Bright	175.53	''	01/11/95
Phillip Harrison, 95 Vincent Road, Morwell	173.60	''	31/01/98
Edward Blake, 13 Pruden Street, Moe	167.05	''	23/04/96
Caroline Yakop, 19 Coolabah Drive, Churchill	162.35	''	31/08/97
Bravick Developments, Lot 21, Tilba Court, Berwick	155.65	''	31/10/97
G.M. & P.L. Costello, Fcty2, 39 Northcote Drive, Thomastown	151.99	''	28/02/98
Konica Business Machines, 171 Ferreras St, South Melbourne	148.00	''	02/01/96
Sutherlands Concrete P/L, P.O. Box 192, Yarram 3971	146.00	''	10/05/96
Gail Sabenkov, 11 Casey Drive, Berwick	144.30	''	15/02/96
Australia Post, G.P.O. Box 2137T, Melbourne 3001	144.00	''	04/04/96
The Independent Weekly, P.O. Box 249, Myrtleford 3737	144.00	''	30/09/96
Valley Cycle, P.O. Box 3245, Morwell Mail Centre 3841	142.45	''	19/03/97
Lilydale Garden Centre, 2/ Lot 2, Melba Avenue, Lilydale	140.50	''	30/07/96
G.W. Hamill, Melbourne	139.82	''	19/09/96
Citipower P/L, Attn: Julie Williams,			
Level 15, 624 Bourke St Melbourne	136.69	''	14/12/95
Telecom Australia, 60 Robinson Street	135.00	''	15/07/96
I. MC N. Jack, Lot 4, Spring Road, Silvan South	134.00	''	31/01/98

Nelly & Sheilla Kazoba, 12 Holmes Court	129.40	”	22/10/96
Thomson, Murray, Fact1, 15 MacQuaries Place, Boronia	127.58	”	30/11/97
Yu, Yi-Ting, 61 Mc Donald Wy, Churchill	125.80	”	28/02/98
Goddard, Cybil, Hadfield Road, Wallan East	118.00	”	30/11/97
Virginia Ahern, 45 Merrin Cr, Wonthaggi	107.30	”	30/09/97
Kenneth Leslie, 12 Bannga Road, Morphett Vale, SA	106.35	”	04/10/96
Pacific Access Pty Ltd, 42 Bailey Street, Bairnsdale	105.55	”	28/02/98
Jim R. Taylor, Malcolms Lane, Boisdale	101.50	”	31/01/98
Hot Line Plumbing Services P/L, 2 Outlook Rd, Mt Waverley	100.00	”	28/11/95

99034

CONTACT: BRENDA YIP, PHONE: (03) 9229 6000.

Unclaimed Moneys Act 1962

Register of Unclaimed Moneys held by the —

<i>Name of Owner on Books and Last Known Address</i>	<i>Total Amount Due to Owner</i>	<i>Description Of Unclaimed Money</i>	<i>Date</i>
			<i>when Amount first became Payable</i>
MURRAY GOULBURN CO-OPERATIVE CO. LTD			
	\$		
Hilder, N.	123.50	Creditor	31/01/97
Evans, N., 23 Wesak Drive, Warrnambool	220.00	”	11/02/97
Treffers, I.G.B.	106.75	”	18/02/97
Dairy Industry Association, Dairy Association of Australia	120.00	”	24/02/97
Bartlett, L. G. & K. M., R.M.B. 5495, Port Fairy	134.32	Dividend	01/05/97
Gillie, R. I & M. G., 35 Banyule Court, Kyabram	191.08	”	”
Keetley, G. & A., 62 Knights Drive, Glen Waverley	191.68	”	”
Latham, F. I. M. & D. W. & N. R., C/- Oakleys White, P.O. Box 24, Foster	151.13	”	”
Loader, N. J. & T. R., P.O. Box 162, Korumburra	177.05	”	”
McLellan, A. F., C/- M. McLellan, 16 Arundel Crescent, Surrey Hills	100.92	”	”
McQueen, G. I., 5 Karmai Court, Korumburra	420.00	”	”
Norwal Pty Ltd, Parkhills BDD Services, 500 Collins Street, Melbourne	104.92	”	”
Spencer, G. J. & F. J., Buderim Newsagency, The Hub, Burnett Street, Buderim, Queensland	117.56	”	”
Surkitt, C. J. & A. M., R.M.B. 7660, Dingey Road, via Allansford	474.30	”	”
Thornton, D. C., McMillans via Cohuna	219.04	”	”
Allen, G. S. & L. M., R.M.B. 7195, Reillys Road, Nerrena	613.25	”	1/11/97
Chester, A. & K., R.M.B. 5245, Sale	168.60	”	”
Considine, K. M., Farmers Road, Meeniyah	280.00	”	”
Cooper, D. C. & K. M., R.M.B. 6780, Wodonga	172.85	”	”
Gardner, G. D. & P. L., Church Lane, Milawa	187.44	”	”
Jans, T. M. & M., McDonalds Road, Meeniyah	255.15	”	”

Keetley, G. & A., 62 Knights Drive, Glen Waverley	191.68	''	''
Kerr, P. A. & K. A., Falls Road, Fish Creek	114.20	''	''
Kincaid, I. E., Balook Road, Callignee	126.02	''	''
Latham, D. W. & C. G., Waratah Road, Fish Creek	892.71	''	''
Le Page, C. P., Buffalo Road, Stony Creek	103.56	''	''
Le Page, C. P. & F. L., Buffalo Road, Stony Creek	392.73	''	''
Norwal Pty Ltd, Parkhills BDO Services P/L, 500 Collins Street, Melbourne	104.92	''	''
Peace, S. A. & S., RSD 546, Leitchville	430.73	''	''
Pocklington, K. F. & P., Dumbalk	117.00	''	''
Pouw, G. W. & J., Yarragon Road, Wooreen via Leongatha	119.52	''	''
Richardson, E. A. (Estate), C/- D. Paulsen, 5 Powderham Road, Caulfield North	120.00	''	''
Sheehan, D. J. & D. L. & P. C., RMB 4730, Port Fairy	369.75	''	''
Spencer, G. J. & F. J., Shop 13, The Hub, Burnett Street, Buderim, Queensland	117.56	''	''
Spencer, M. G., Waverley, Leongatha North	272.84	''	''
Sperling, A. R. & B. J., Whitelaws Track, Leongatha South	420.28	''	''
Stefani, D. & B., Keane's Road, Fish Creek	604.70	''	''
Stefani, F. & N., Carnegie Road, Fish Creek	391.55	''	''
Stewart, I. N. & Y. R., RMB 2040, Moyhu	112.64	''	''
Viergever, I. & K., RMB 5425, Mt Vernon Rd, Berrys Creek	124.36	''	''
Zuidema, H. J. & C. G., RMB 4860, Canavans Rd, Mt Eccles	213.30	''	''
Odgers, A. R., 785 Korumburra South Rd, Korumburra South	326.10	''	17/11/97
Tait, I. J., RMB 7330, Airly via Sale	213.12	''	''
Moorehouse Pty Ltd, RMB 1049A, Jelbarts Road, Nathalia	161.74	Milk Supply	15/05/97
Gooding, R. J. & C. M., RMB 1088, Waaia	156.40	''	19/05/97
Osborne, G. A., RMB 2770, Katunga	240.54	''	15/10/97

99009

CONTACT: LYNDA HARVEY, PHONE: (03) 9389 6472.

PROCLAMATIONS

Rail Corporations (Amendment) Act 1997
PROCLAMATION OF COMMENCEMENT

I, James Gobbo, Governor of Victoria, with the advice of the Executive Council and under section 2(2) of the **Rail Corporations (Amendment) Act 1997**, fix 29 April 1999 as the day on which the remaining provisions (except sections 4, 36 and 37) of that Act come into operation.

Given under my hand and the seal of Victoria on 28 April 1999.

(L.S.) JAMES GOBBO
Governor
By His Excellency's Command

ROBIN COOPER
Minister for Transport

Rail Corporations (Amendment) Act 1998
PROCLAMATION OF COMMENCEMENT

I, James Gobbo, Governor of Victoria, with the advice of the Executive Council and under section 2(2) of the **Rail Corporations (Amendment) Act 1998**, fix 29 April 1999 as the day on which section 10 of that Act comes into operation.

Given under my hand and the seal of Victoria on 28 April 1999.

(L.S.) JAMES GOBBO
Governor
By His Excellency's Command

ROBIN COOPER
Minister for Transport

Rail Corporations (Further Amendment) Act 1998
PROCLAMATION OF COMMENCEMENT

I, James Gobbo, Governor of Victoria, with the advice of the Executive Council and under section 2(2) of the **Rail Corporations (Further Amendment) Act 1998**, fix 29 April 1999 as the day on which the following provisions of that Act come into operation:

- (a) Part 2 (except section 16);
- (b) Sections 20, 21, 23, 24, 34, 35, 37, 38 and 39;
- (c) the remaining provisions of Part 4 (except section 48).

Given under my hand and the seal of Victoria on 28 April 1999.

(L.S.) JAMES GOBBO
Governor
By His Excellency's Command

ROBIN COOPER
Minister for Transport

Electricity Safety Act 1998
PROCLAMATION OF COMMENCEMENT

I, James Gobbo, Governor of Victoria, acting with the advice of the Executive Council and under section 2(2) of the **Electricity Safety Act 1998**, fix 3 May 1999 as the day on which the following provisions of that Act come into operation -

- (a) the remaining provisions of Part 3;
- (b) Parts 4 and 5;
- (c) Part 6 (except section 70(4));
- (d) Part 9;
- (e) section 128;
- (f) Division 1 of Part 12;
- (g) sections 152, 153, 154, 155, 156, 160, 161, and 163(1)(d);
- (h) Schedule 1.

Given under my hand and the seal of Victoria on 28 April 1999.

(L.S.) JAMES GOBBO
Governor
By His Excellency's Command

ALAN R. STOCKDALE
Treasurer

Electricity Industry Acts (Amendment) Act 1998
PROCLAMATION OF COMMENCEMENT

I, James Gobbo, Governor of Victoria, acting with the advice of the Executive Council and under section 2(2) of the **Electricity Industry Acts (Amendment) Act 1998**, fix 3 May 1999 as the day on which sections 5, 7, 8, 9, 10, 11, 12, 13(1), 22, 27, 28, 29 and 30 of that Act come into operation.

Given under my hand and the seal of Victoria on 28 April 1999.

(L.S.) JAMES GOBBO
Governor
By His Excellency's Command

ALAN R. STOCKDALE
Treasurer

ACTS OF PARLIAMENT
Proclamation

I, James Gobbo, Governor of Victoria, declare that I have today assented in Her Majesty's name to the following Bills:

- No. 1/1999 **Barley Marketing (Amendment) Act 1999**
- No. 2/1999 **Environment Protection (Amendment) Act 1999**
- No. 3/1999 **Statute Law Revision (Repeals) Act 1999**
- No. 4/1999 **Tattersall Consultations (Amendment) Act 1999**
- No. 5/1999 **Transport Accident (Further Amendment) Act 1999**
- No. 6/1999 **Transport Acts (Further Amendment) Act 1999**

Given under my hand and the seal of Victoria at Melbourne on 28 April 1999.

(L.S.)

JAMES GOBBO
Governor of Victoria
By His Excellency's Command
J. G. KENNETT
Premier

Land Act 1958
PROCLAMATION OF ROAD

I, James Gobbo, Governor of Victoria acting with the advice of the Executive Council and under Section 25(3)(c) of the **Land Act 1958**, proclaim as road the following land:

MUNICIPAL DISTRICT OF THE MAROONDAH CITY COUNCIL

RINGWOOD — The land in the Parish of Ringwood shown by hatching on plan hereunder. (R72[6]) — (12/L12-0999).

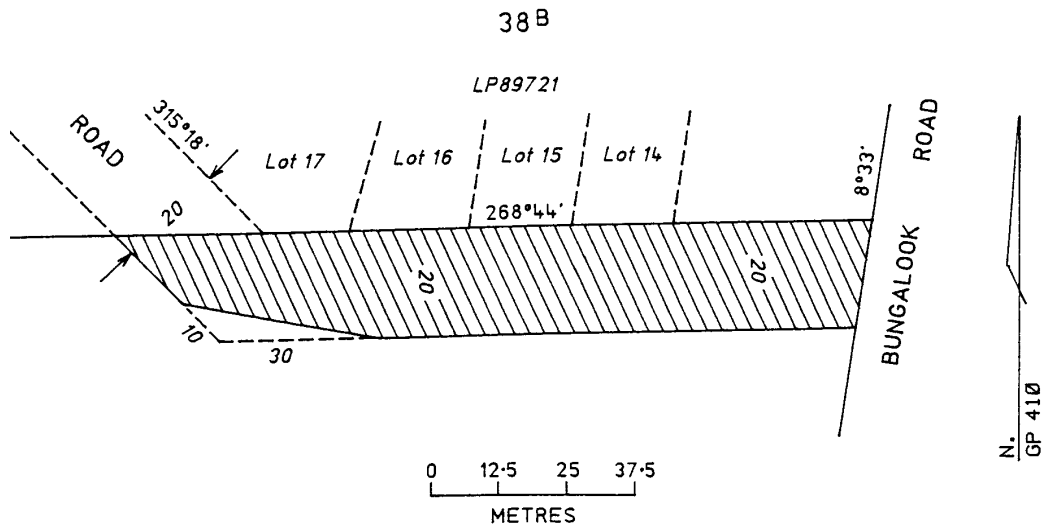

This Proclamation is effective from the date on which it is published in the Victoria Government Gazette.

Given under my hand and the seal of Victoria on 28 April 1999.

(L.S.)

JAMES GOBBO
Governor
By His Excellency's Command
MARIE TEHAN, MP
Minister for Conservation
and Land Management

**GOVERNMENT AND OUTER BUDGET SECTOR AGENCIES
NOTICES**



DELATITE SHIRE

ROAD EXCHANGE/ROAD CLOSURE

Parish of Howqua

Pursuant to the provisions of clause 2, Schedule 10 of the **Local Government Act 1989**, the Council, having advertised its intentions in local papers and received no submissions pursuant to Section 223 of the **Local Government Act 1989**, has resolved under instrument of delegation by the Chief Executive Officer, to authorise and approve the road exchange and closure set out on the plan below.

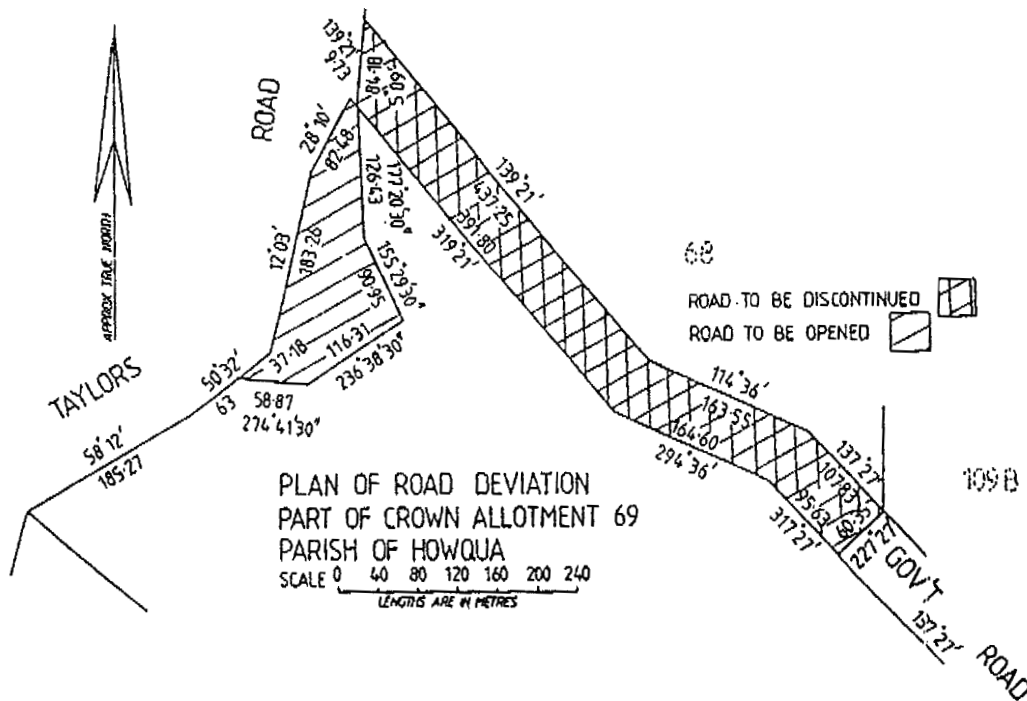

ROBERT DOBRZYNSKI
Chief Executive Officer

**WEST WIMMERA SHIRE COUNCIL
Road Discontinuance/Deviation**

The West Wimmera Shire Council at its ordinary meeting formed the opinion that the road in the Parish of Dopewora situated south of Crown Allotment 29 and east of Crown Allotment 76C in the said Parish is not reasonably required as a road for public use and resolved to discontinue the road and hereby orders that the said road be discontinued

pursuant to Schedule 10, Clause 2 of Section 206 of the **Local Government Act 1989**, and the land of the discontinued road vest in the Council pursuant to Section 207B of the said Act and be exchanged with the road R1 on Plan of Subdivision No. PS339074E, Parish of Dopewora.

KEVIN HANNAGAN
Chief Executive Officer

GREATER GEELONG CITY COUNCIL
Road Discontinuance

Under Section 206 and Schedule 10 Clause 3 of the **Local Government Act 1989** the Greater Geelong City Council at its Ordinary meeting held on 14 April 1999, formed the opinion that the road shown hatched on the plan below is not reasonably required as a road for public use and has resolved to discontinue the road and to sell the land from the road by private treaty.

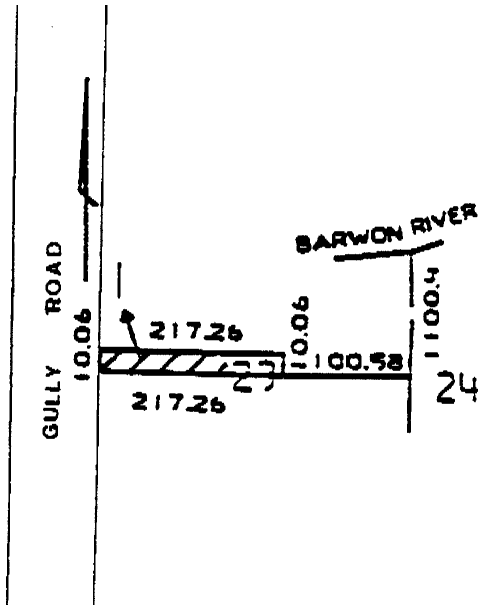

GEOFF WHITBREAD
Chief Executive Officer



ERRATUM

Discontinuance of Roads Adjoining Lots 1-13
LP 33881 Point Nepean Road, Sorrento

Notice is hereby given that the rights saved in the notice published in the Victoria Government Gazette G22 dated 5 June 1997, on page 1285, are superseded by this notice.

The rights saved in favour of United Energy Limited are to be removed and rights are now to be saved in favour of the State Electricity Commission of Victoria.

MICHAEL KENNEDY
Chief Executive Officer



Public Holidays Act 1993

Mitchell Shire Council in accordance with Section 7(1) (b) of the **Public Holidays Act 1993**, has declared:-

- (i) A full day public holiday for the townships of Seymour, Puckapunyal and Tallarook on Tuesday 26 October 1999 for the Seymour Cup; and
- (ii) A full day public holiday for the area known as Kilmore township on Wednesday 1 March 2000 for the Kilmore Turf Cup.

In accordance with Section 9(a) of the **Public Holidays Act 1993**, a full day bank holiday will apply for the townships specified in (i) and (ii) on the dates nominated.

GARRY CECIL
Chief Executive Officer

NORTH EAST REGION WATER
AUTHORITY

Declared Sewerage Areas
Kiewa/Tangambalanga

Notice is hereby given pursuant of Section 144 of the **Water Act 1989** that properties in the Kiewa and Tangambalanga Township area are declared as serviced for sewerage on and from 5 May 1999. The properties declared as serviced by sewer are in the following areas: 2, 4, 6, 8, 10, 12, 14, 16 and 18 Gentle Road; lots 10 and 11 Samuel Street; lots 19 and 20 Jessica Court; lots 12 - 18 Emily Close; 1 - 16 and PT12 Kiewa Valley Court; 1A, 1, 3A, 4 - 35 37, 41, 43, 45, 47, 49, 51, 53 and 55 Kiewa Huon Road; 1 - 12 and PT4A Kiewa Bonegilla Road; 2, 4, 6, 8, 10, 12, 14, 16, 18, 20, 22, 24, 26, 28, 29, 30, 31, 33 and lot 2A Kiewa East Road, Kiewa; 14, 16, 18 - 35, 37 - 64, 66 - 73 and 75 Kiewa East Road, Tangambalanga, 1, 2, 3, 5, 7, 9, 11, 13, 15, 17, 19, 21, 23 and 25 Quoney Road; 1 - 12 Murra Court; 1 - 7 Walcha Street; 2, 4, 6, 8, 10, 12, 14, 16, 18, 20 and 22, lots 1 - 5, PT4 and lot 8 Kiewa Valley Highway.

The plan of the declared area is available for inspection at the office of North East Region Water Authority, Level 1, Hovell Street, Wodonga, Victoria 3690 between 9.00 a.m. and 5.00 p.m. Monday to Friday.

J. B. O'BRIEN

BASS COAST SHIRE COUNCIL
Making of Local Laws

Notice is hereby given in accordance with Section 119 of the **Local Government Act 1989** that the Bass Coast Shire Council, at its meeting on 21 April 1999, resolved to make Local Law No. 8 entitled **Council Roads and Land Local Law** and Local Law No. 9 entitled **Environment and Amenity Local Law**.

Local Law No. 8 – Council Roads and Land

The purpose of the Local Law is to provide for the peace, order, and good government of the Bass Coast Shire in a way that is complimentary to the goals in the Council's Community Plan by:-

- (a) managing the uses and activities on roads and Council land so that the council is aware of uses or activities which may:-
 - interfere with the safety and convenience of people travelling on or using the road or Council land; and
 - impede free and safe access for people, in particular those with sight and movement impairment or disabilities; and
 - cause damage to Council and community assets; and
 - create a danger or expose others to risk; and
 - be detrimental to the amenity of the area or the enjoyment of facilities on roads or council land.
- (b) identifying activities and uses on roads and Council land where a permit is not required but conditions are applicable to the use so that the purposes identified in paragraph (a) are achieved;
- (c) identifying activities and uses that are not permitted on roads and Council land;
- (d) providing for the administration of the Council's powers and functions.

The general purport of the Local Law is to:-

- specify that a permit must be obtained from the Council before a person uses a road or Council land for the following activities:-
 - (a) constructing or altering a vehicle crossing;
 - (b) installing a temporary vehicle crossing;

- (c) using a heavy vehicle contrary to a signed restriction;
- (d) grazing livestock;
- (e) driving livestock through the municipal district;
- (f) placing directional signs;
- (g) placing advertising signs in business and industrial areas;
- (h) trading from a vehicle;
- (i) trading from door to door;
- (j) displaying goods and services for sale or hire;
- (k) placing tables and chairs;
- (l) placing bulk rubbish containers;
- (m) occupying the road for works;
- (n) having a street party, festival or procession;
- (o) collecting money, gifts or subscriptions
- (p) busking;
- (q) placing posters, signs or advertisements or graffiti on Council buildings and fixtures; and
- (r) landscaping, planting trees, shrubs and other vegetation on Council land.
- specify that a person must observe the requirements applied in the Local Law to:-
 - (a) the location of trees, plants and signs on a person's property which obstruct or interfere with pedestrians or vehicular traffic;
 - (b) the display of property numbers;
 - (c) naming a road;
 - (d) vehicle crossings for vehicle access;
 - (e) redundant vehicle crossings;
 - (f) fencing to contain livestock;
 - (g) using toy vehicles;
 - (h) moving livestock from one property to another in the municipal district.
- specify that the following activities are not permitted on Council roads or Council land:-
 - (a) trading from another person's designated site;
 - (b) using toy vehicles in prohibited areas;
 - (c) riding or leading a horse on a road or Council land if the activity is causing a

nuisance to pedestrians or vehicles or damage to the road or Council land;

- (d) leaving a shopping trolley anywhere other than in an area or at a collection point designated for the return of shopping trolleys;
 - (e) dismantling, painting, carrying out maintenance or repairs on a vehicle on a road except where it is necessary to enable the vehicle to be removed;
 - (f) damaging roads or Council land;
 - (g) boisterous or harmful behaviour interfering with the quiet enjoyment of Council land by other people;
 - (h) smoking in smoke free areas.
- providing for the issue of permits and infringement notices by Council.

Local Law No. 9 – Environment and Amenity

The purpose of the Local Law is to provide for the peace, order, and good government of the Bass Coast Shire in a way that is complimentary to the goals in the Council's Community Plan by:-

- (a) managing activities and uses on roads and Council land which may be dangerous, cause a nuisance or be detrimental to the amenity of the area or the environment;
- (b) regulating and controlling activities to maintain a healthy and safe environment in the municipal district for residents and visitors;
- (c) identifying requirements or conditions that must be observed to ensure that a safe, healthy and enjoyable environment for residents and visitors is maintained;
- (d) providing for the administration of the Council's powers and functions.

The general purport of the Local Law is to:-

- specify that a permit must be obtained from the Council before a person undertakes any of the following activities:-
 - (a) using a recreational vehicle on Council land or private land;
 - (b) using the Council's designated boat ramps;
 - (c) camping on Council land or public land;
 - (d) camping on private vacant land;
 - (e) conducting carnivals and festivals;

- (f) scavenging at the resource recovery centre;
- (g) connecting into Council drains;
- (h) lighting fires in the open air in a built up area;
- (i) lighting fires on Council land;
- (j) interfering with or removing native vegetation from Council land.

- specify the activities or uses where a person must observe the conditions applied to them in this Local Law:-
 - (a) floodlighting on properties;
 - (b) adequate animal shelters;
 - (c) waste and recyclable materials;
 - (d) commercial and industrial trade waste;
 - (e) transportation of wastes;
 - (f) use of resource recovery centre;
 - (g) dumping of refrigerators and ice chests.
- specify the activities and uses not permitted:-
 - (a) the keeping of land in dangerous or undightly manner;
 - (b) playing a musical instrument, shouting, singing or haranguing in a public place in a way that it is objectionable to other people;
 - (c) placing household, commercial or industrial waste in Council litter bins on any Council land or road;
 - (d) removing recyclable material left for collection;
 - (e) allowing a nuisance fire to remain alight;
 - (f) burning certain substances;
 - (g) taking of glass into a designated glass drink container free zone; and
 - (h) using a recreation vehicle on a Total Fire Ban Day.
- providing for the issue of permits and infringement notices by Council.

Council also prepared a **Local Laws Policy and Procedures Manual** which includes:-

- procedures applying to the exercise of Council's powers in relation to roads and traffic under the **Local Government Act 1989**; and

- a Signage in Public Places Policy.

The proposed Local Laws should be read in conjunction with the Manual.

Copies of the Local Laws and the Local Laws Policy and Procedures Manual may be inspected at, or obtained free of charge, from any of the following Council Customer Service Centres:-

- 76 McBridg Avenue, Wonthaggi;
- 91-97 Thompson Avenue, Cowes;
- 3 Reilly Street, Inverloch;
- Shop 3, Bass Highway, Grantville.

These Local Laws operate from 21 April 1999.

ALLAN BAWDEN
Chief Executive Officer

Creditors, next of kin and others having claims against the estate of any of the undermentioned deceased persons are required to send particulars of their claims to State Trustees Limited, A.C.N 064 593 148, 168 Exhibition Street, Melbourne, Victoria, 3000 the personal representative, on or before July 2, 1999 after which date State Trustees Limited may convey or distribute the assets having regard only to the claims of which State Trustees Limited then has notice.

FOORD Vivian Glen, late of 2/17 Preston Street, Coburg, pensioner, who died February 13, 1999.

KIRCHENBERGER Bruno Hans, late of 42 Rowson Street, Boronia, retired, who died January 8, 1999.

KNOTT Roy McIvor, late of Kupiano Central Province of Papua New Guinea, store keeper, who died December 25, 1990.

LYNCH Alice Mary, late of Burnside Private Nursing Home, 54 Burnside Street, Deer Park, pensioner, who died March 9, 1999.

McDONALD Victor Hyde, late of Beechworth Hospital, Beechworth, pensioner, who died December 7, 1998.

PURDON Valerie Joy, late of Benlyne Private Nursing Home, 10 Nolan Street, Frankston, retired, who died February 5, 1999.

WEST Dorothy Jean, late of 3 Burns Street, Maidstone, home duties, who died February 25, 1999.

Dated at Melbourne, 23 April 1999.

CATHY VANDERFEEN
Manager, Estate Management
State Trustees Limited

Creditors, next-of-kin and others having claims against the following estates:-

DRAPER, Ann, late of Unit 13, Mitchell House, 127 Vary Street, Morwell, Victoria, retired, deceased, who died on February 11, 1999.

HARMSWORTH, Jack Reginald, late of Inala Village, 220 Middleborough Road, Blackburn South, Victoria, retired, deceased, who died on March 13, 1999.

RADTKE, Frederick Bernard, late of Flat 1, 3A Munro Street, Hawthorn, Victoria, pensioner, deceased intestate, who died November 18, 1997.

REID, Arthur Paul, late of 183B Melrose Drive, Tullamarine, Victoria, retired, deceased intestate, who died September 10, 1998.

ROBINSON, Robert Gordon, who was late of 4/2 Wimmera Street, Jeparit, Victoria, carpenter, deceased, who died January 29, 1999.

STOREN, William James, who was late of Coogee Private Nursing Home, 7 Coogee Street, Boronia, Victoria, retired, deceased, who died April 3, 1999.

Creditors, next-of-kin and others having claims against the abovementioned estates are required pursuant to Section 33 of the **Trustee Act 1958** to send particulars of their claims against the abovementioned estates to State Trustees Limited, 168 Exhibition Street, Melbourne, Victoria, on or before June 24 1999, after which date State Trustees Limited, A.C.N. 064 593 148, may convey or distribute the assets of the abovementioned estates having regard only to the claims of which it then has notice.

Department of Treasury and Finance

SALE OF CROWN LAND
BY PUBLIC AUCTION

Date of Auction: 15 May, 1999 at 11.15 a.m.,
on site.

Reference: E8347/14.

Address of Property: Wren Street, Toolamba.

Crown Description: Crown Allotment 66K, Parish of Toolamba.

Terms of Sale: Deposit 10% - Balance 60 days.

Area: 1578m².

Officer Co-ordinating Sale: Peter Hollins, Victorian Government Property Group, Department of Treasury and Finance, 10/1 Macarthur Street, Melbourne, Vic. 3002.

Selling Agent: Flanagan & Reed Real Estate, 182 High Street, Shepparton, Vic. 3630. Telephone: (03) 5831 1800. Facsimile: (03) 5831 7898.

ROGER M. HALLAM
Minister for Finance

Department of Treasury and Finance

SALE OF CROWN LAND
BY PUBLIC AUCTION

Date of Auction: 15 May, 1999 at 12.30 p.m., on site.

Reference: E8347/17.

Address of Property: East of Goulburn Valley Highway, Kialla West.

Crown Description: Crown Allotments 13 & 15, Parish of Kialla.

Terms of Sale: Deposit 10% - Balance 60 days.

Area: 7.208ha.

Officer Co-ordinating Sale: Peter Hollins, Victorian Government Property Group, Department of Treasury and Finance, 10/1 Macarthur Street, Melbourne, Vic. 3002.

Selling Agent: Flanagan & Reed Real Estate, 182 High Street, Shepparton, Vic. 3630. Telephone: (03) 5831 1800. Facsimile: (03) 5831 7898.

ROGER M. HALLAM
Minister for Finance

Department of Treasury and Finance

SALE OF CROWN LAND
BY PUBLIC AUCTION

Date of Auction: 15 May, 1999 at 10.00 a.m., on site.

Reference: E8347/11.

Address of Property: Verney Road, Shepparton.

Crown Description: Crown Allotment 78T, Parish of Shepparton.

Terms of Sale: Deposit 10% - Balance 60 days.

Area: 760m².

Officer Co-ordinating Sale: Peter Hollins, Victorian Government Property Group, Department of Treasury and Finance, 10/1 Macarthur Street, Melbourne, Vic. 3002.

Selling Agent: Flanagan & Reed Real Estate, 182 High Street, Shepparton, Vic. 3630. Telephone: (03) 5831 1800. Facsimile: (03) 5831 7898.

ROGER M. HALLAM
Minister for Finance

Department of Treasury and Finance

SALE OF CROWN LAND
BY PUBLIC AUCTION

Date of Auction: 14 May 1999 at 11.00 a.m. at the Mingling Waters Restaurant, Princes Highway, Nowa Nowa.

Reference: 98/02796.

Address of Property: Off Princes Highway, Tostaree.

Crown Description: Crown Allotment 13, Parish of Tildesley West.

Terms of Sale: Deposit 10% - Balance 60 days.

Area: 8,654 square metres.

Officer Co-ordinating Sale: Peter Hollins, Victorian Government Property Group, Department of Treasury and Finance, 10/1 Macarthur Street, Melbourne, Vic. 3002.

Selling Agent: King and Heath, First National Real Estate, 110 Nicholson Street, Orbost, Vic. 3888.

ROGER M. HALLAM
Minister for Finance

Department of Treasury and Finance

SALE OF CROWN LAND
BY PUBLIC AUCTION

Date of Auction: 14 May 1999 at 11.00 a.m. at the Mingling Waters Restaurant, Princes Highway, Nowa Nowa.

Reference: 98/02795.

Address of Property: School Road, Nowa Nowa.

Crown Description: Crown Allotment 15A, Section C, Parish of Ninnie.

Terms of Sale: Deposit 10% - Balance 60 days.

Area: 3,345 square metres.

Officer Co-ordinating Sale: Peter Hollins, Victorian Government Property Group, Department of Treasury and Finance, 10/1 Macarthur Street, Melbourne, Vic. 3002.

Selling Agent: King and Heath, First National Real Estate, 110 Nicholson Street, Orbost, Vic. 3888.

ROGER M. HALLAM
Minister for Finance

Department of Treasury and Finance

SALE OF CROWN LAND
BY PUBLIC AUCTION

Date of Auction: 14 May 1999 at 11.00 a.m. at the Mingling Waters Restaurant, Princes Highway, Nowa Nowa.

Reference: 98/02798.

Address of Property: George Road, Nowa Nowa.

Crown Description: Crown Allotment 1E, Section C, Parish of Ninnie.

Terms of Sale: Deposit 10% - Balance 60 days.

Area: 5,177 square metres.

Officer Co-ordinating Sale: Peter Hollins, Victorian Government Property Group, Department of Treasury and Finance, 10/1 Macarthur Street, Melbourne, Vic. 3002.

Selling Agent: King and Heath, First National Real Estate, 110 Nicholson Street, Orbost, Vic. 3888.

ROGER M. HALLAM
Minister for Finance

Department of Treasury and Finance

SALE OF CROWN LAND
BY PUBLIC AUCTION

Date of Auction: 15 May 1999 at 11.30 a.m. on site.

Reference: 98/02741.

Address of Property: South Road, Woodend.

Crown Description: Crown Allotment 12, Section 6, Parish of Woodend.

Terms of Sale: Deposit 10% - Balance 60 days.

Area: 2.812 hectares.

Officer Co-ordinating Sale: Peter Hollins, Victorian Government Property Group,

Department of Treasury and Finance, 10/1 Macarthur Street, Melbourne, Vic. 3002.

Selling Agent: Conally's Real Estate, 108-110 High Street, Woodend, Vic. 3442.

ROGER M. HALLAM
Minister for Finance

Department of Treasury and Finance

SALE OF CROWN LAND
BY PUBLIC AUCTION

Date of Auction: 15 May 1999 at 11.00 a.m. on site.

Reference: 98/02740.

Address of Property: Quarry Road, Woodend.

Crown Description: Crown Allotment 12, Section 8, Parish of Woodend.

Terms of Sale: Deposit 10% - Balance 60 days.

Area: 1,125 square metres.

Officer Co-ordinating Sale: Peter Hollins, Victorian Government Property Group, Department of Treasury and Finance, 10/1 Macarthur Street, Melbourne, Vic. 3002.

Selling Agent: Conally's Real Estate, 108-110 High Street, Woodend, Vic. 3442.

ROGER M. HALLAM
Minister for Finance

Department of Treasury and Finance

SALE OF CROWN LAND
BY PUBLIC AUCTION

Date of Auction: 15 May 1999 at 12 noon on site.

Reference: 98/02742.

Address of Property: Blackmores Road, Woodend.

Crown Description: Crown Allotment 9, Section 15, Parish of Woodend.

Terms of Sale: Deposit 10% - Balance 60 days.

Area: 3.89 hectares.

Officer Co-ordinating Sale: Peter Hollins, Victorian Government Property Group, Department of Treasury and Finance, 10/1 Macarthur Street, Melbourne, Vic. 3002.

Selling Agent: Conally's Real Estate, 108-110 High Street, Woodend, Vic. 3442.

ROGER M. HALLAM
Minister for Finance

Geographic Place Names Act 1998
REGISTRAR OF GEOGRAPHIC PLACE NAMES

1. NOTICE OF REGISTRATION OF GEOGRAPHIC NAMES

The Registrar of Geographic Names hereby gives notice of the registration of the undermentioned towns and rural districts.

File No.	Place Name	Proposer & Location
1735	Balmoral, Bellfield, Bochara, Branxholme, Brit Brit, Buckley Swamp, Bulart, Byaduk, Byaduk North, Caramut, Carapook, Cavendish, Cherrypool, Clover Flat, Coleraine, Coojar, Croxton East, Culla, Dunkeld, Englefield, Gatum, Gazette, Glenisla, Glenthompson, Grampians, Gringegalgon, Gritjurk, Hamilton, Harrow, Hensley Park, Hilgay, Karabeal, Konongwootong, Melville Forest, Mirranatwa, Mooralla, Morgiana, Mount Napier, Moutajup, Muntham, Nareeb, Nareen, Penshurst, Pigeon Ponds, Purdeet, Rocklands, Strathkellar, Tabor, Tahara, Tarrayoukyan, Tarrenlea, Tarrington, Vasey, Victoria Point, Victoria Valley, Wando Vale, Wannon, Warrayure, Woodhouse, Wootong Vale, Yatchaw, and Yulecart.	Shire of the Southern Grampians. Entry into the Register of the 62 aforementioned towns and rural districts within the municipality. Plans may be inspected at the Municipal Offices, or the office of the Registrar of Geographic Names.
1616	Tolem Vale	Shire of Melton. Entry into the Register of the 1 aforementioned rural district within the municipality. Plans may be inspected at the Municipal Offices, or the office of the Registrar of Geographic Names.

CORRIGENDUM

The Victoria Government Gazette No. G 38, 24 September 1998, page 2464, under Notice of Assignment of Place Names, the following Place Name of Pomonial, within the Shire of Northern Grampians, should read Pomonal.

The Victoria Government Gazette No. G 1, 7 January 1999, page 23, under Notice of Assignment of Place Names, the following Place Names of Igana Creek, Gypsy Point, and Bairnsdale East, within the Shire of East Gippsland, should read Igana Creek, Gypsy Point and East Bairnsdale. Included within the Shire of East Gippsland should also be the districts of Dartmouth, Deddick Valley and Deptford.

The Victoria Government Gazette No. G 29, 23 July 1998, page 1987, under Notice of Assignment of Place Names, the following Place Names of Calligne and Darlmurla, within the La Trobe Shire, should read Callignee and Darlimurla.

The Victoria Government Gazette No. G 29, 23 July 1998, page 1988, under Notice of

Assignment of Place Names, the following Place Names of Minnera and Ross Bridge, within the Rural City of Ararat, should read Mininera and Rossbridge.

Office of the Registrar of Geographic Names

c/-LAND VICTORIA

2nd Floor

456 Lonsdale Street

MELBOURNE 3000

JOHN PARKER

Registrar of Geographic Names

Private Agents Act 1966

NOTICE OF RECEIPT OF APPLICATIONS FOR LICENCES UNDER THE PROVISIONS OF THE PRIVATE AGENTS ACT 1966

I, the undersigned, being the Deputy Registrar of the Melbourne Magistrates' Court hereby give notice that applications, as under have been lodged for hearing by the said Court on the date specified.

Any person desiring to object to any such application must:

- (a) lodge with me a notice in the prescribed form of his objection and of the grounds thereof;
- (b) cause a copy of such notice to be served personally or by post upon the applicant at least three days before the hearing of the application; and
- (c) send or deliver
 - (i) where the objection is not made by the officer in charge of the police district in which the Court is situated — a copy of the notice to such officer; and
 - (ii) where the objection is not made by the Registrar or Deputy Registrar — a copy to the Registrar.

<i>Full name of Applicant or in the case of a Firm or Corporation, of the Nominee</i>	<i>Place of Abode of Applicant or Nominee</i>	<i>Name of Firm or Corporation</i>	<i>Address for Registration</i>	<i>Type of Licence</i>	<i>Date of Hearing of Application</i>
Allison Dorothy Wendt	Unit 3, 11 Currajong Street, Glenroy	Advanced Credit Management (Vic) P/L	Unit 3, 11 Currajong Street, Glenroy	Commer- cial sub- agent	7/5/99
Michelle Louise Berry	36 Wiltonvale Avenue, Hoppers Crossing, Vic. 3029	Advanced Credit Management (Vic) P/L	36 Wiltonvale Avenue, Hoppers Crossing, Vic. 3029	Commer- cial sub- agent	”
Suzanne Rangan	47 Golf Road, Coburg, Vic. 3058	Advanced Credit Management (Vic) P/L	47 Golf Road, Coburg, Vic. 3058	Commer- cial sub- agent	”
Marcia Claudia Santos	2 Hedgerow Court, East Keilor,	Advanced Credit Management	2 Hedgerow Court, East Keilor,	Commer- cial sub- agent	”

Dimitrios Jim Massouridis	Vic. 3033 12 Waverley Parade, Pascoe Vale South, 3044	(Vic) P/L Advanced Credit Management (Vic) P/L	Vic. 3033 12 Waverley Parade, Pascoe Vale South, 3044	Commer- cial sub- agent	”
Joe Fratangelo	8 Waltham Place, Avondale Heights 3034	Advanced Credit Management (Vic) P/L	8 Waltham Place, Avondale Heights 3034	Commer- cial sub- agent	”
Troy David Riha	12 Silvan Court, North Dandenong, Vic. 3175	Advanced Credit Management (Vic) P/L	12 Silvan Court, North Dandenong, Vic. 3175	Commer- cial sub- agent	”
Erwin Code	4 Patterson Street, Bacchus Marsh	Quartermain Support Services	3rd Floor, 423 Bourke Street, Melbourne	Commer- cial sub- agent	”
Lee, Kelly & Associates (Vic) Pty Ltd	Vince Scopelliti, 14 Howard Street, Kew	Lee, Kelly & Associates (Vic) Pty Ltd	72 Faraday Street, Carlton 3053	Commer- cial agent	”
Grazyna Jadwiga Nowak	145 Eramosa Road, Somerville	Quartermain Support Services	3rd Floor, 423 Bourke Street, Melbourne	Commer- cial sub- agent	”

PETER MITHEN

Deputy Registrar Melbourne Magistrates' Court

Private Agents Act 1966

NOTICE OF RECEIPT OF APPLICATIONS FOR LICENCES UNDER THE PROVISIONS OF THE PRIVATE AGENTS ACT 1966

I, the undersigned, being the Deputy Registrar of the Melbourne Magistrates' Court hereby give notice that applications, as under have been lodged for hearing by the said Court on the date specified.

Any person desiring to object to any such application must:

- (a) lodge with me a notice in the prescribed form of his objection and of the grounds thereof;
- (b) cause a copy of such notice to be served personally or by post upon the applicant at least three days before the hearing of the application; and
- (c) send or deliver
 - (i) where the objection is not made by the officer in charge of the police district in which the Court is situated — a copy of the notice to such officer; and
 - (ii) where the objection is not made by the Registrar or Deputy Registrar — a copy to the Registrar.

<i>Full name of Applicant or in the case of a Firm or Corporation, of the Nominee</i>	<i>Place of Abode of Applicant or Nominee</i>	<i>Name of Firm or Corporation</i>	<i>Address for Registration</i>	<i>Type of Licence</i>	<i>Date of Hearing of Application</i>
Paraskeyv (Voula) Azidis	71 Neil Street, Carlton, Vic. 3053	Advanced Credit Management Victoria	71 Neil Street, Carlton, Vic. 3053	Commercial sub-agent	29/05/1999
Margaret Mary Collett	20 Laurie Street, Newport, Victoria 3015	Advanced Credit Management Victoria Pty Ltd	20 Laurie Street, Newport, Victoria 3015	Commercial sub-agent	”
Toula Andriopoulos	48 Derby Street, Northcote, Vic. 3070	Advanced Credit Management (Vic.) P/L	48 Derby Street, Northcote, Vic. 3070	Commercial sub-agent	”
Susan Filipovski	1 Carroll Crescent, Mill Park, Vic. 3082	Advanced Credit Management (Vic.) P/L	1 Carroll Crescent, Mill Park, Vic. 3082	Commercial sub-agent	”
Troy James Graeme Evans	9 Daniel Street, Burwood, Victoria 3125	Advanced Credit Management Victoria Pty Ltd	9 Daniel Street, Burwood, Victoria 3125	Commercial sub-agent	”
Graeme Anthony Gilligan	31 Elizabeth Street, Coburg East	Cardiff Cove Pty Ltd	6 McIlwrick Street, Windsor, Vic. 3181	Commercial sub-agent	”

PETER MITHEN

Deputy Registrar Melbourne Magistrates' Court

Vocational Education and Training Act 1990

NOTICE OF DETERMINATION OF APPROVED TRAINING SCHEMES

In accordance with section 51 of the **Vocational Education and Training Act 1990** the State Training Board of Victoria gives notice that it has determined that the following training schemes are approved training schemes for the vocations specified below:

APPROVED TRAINING SCHEME	DATE OF DETERMINATION
NSW7957 Certificate III in Food Processing (Aerated Waters) - Coca-Cola Amatil	11 January 1999
2311ANC Certificate III in Food Processing (General Foods) - Pasta di Casa	18 January 1999
14458VIC Certificate II in Inland Aquaculture 14460VIC Certificate III in Inland Aquaculture	19 January 1999

<p>MTM20198 Certificate II in Meat Processing (Abattoirs)</p> <p>MTM30198 Certificate III in Meat Processing (Boning)</p> <p>MTM30298 Certificate III in Meat Processing (Laboratory)</p> <p>MTM30398 Certificate III in Meat Processing (Meat Safety)</p> <p>MTM30498 Certificate III in Meat Processing (Rendering)</p> <p>MTM30598 Certificate III in Meat Processing (Slaughtering)</p> <p>MTM40198 Certificate IV in Meat Processing (Leadership)</p> <p>MTM40298 Certificate IV in Meat Processing (Meat Safety)</p> <p>MTM40398 Certificate IV in Meat Processing (Quality Assurance)</p> <p>MTM10198 Certificate I in Meat Processing (Smallgoods)</p> <p>MTM20298 Certificate II in Meat Processing (Smallgoods)</p> <p>MTM30698 Certificate III in Meat Processing (Smallgoods- Laboratory)</p> <p>MTM30798 Certificate III in Meat Processing (Smallgoods - Manufacturing)</p> <p>MTM40498 Certificate IV in Meat Processing (Smallgoods - Leadership)</p> <p>MTM40598 Certificate IV in Meat Processing (Smallgoods - Manufacturing)</p> <p>MTM40698 Certificate IV in Meat Processing (Smallgoods - Quality Assurance)</p>	3 February 1999
2411AGB Certificate IV in Mortuary Science (Embalming)	3 February 1999
<p>RUV20198 Certificate II in Animal Studies</p> <p>RUV30198 Certificate III in Animal Studies</p> <p>RUV40198 Certificate IV in Veterinary Nursing</p>	9 February 1999
14392VIC Certificate II in Powerline (Vegetation Control)	12 February 1999
<p>CSC30198 Certificate III in Correctional Practice (Custodial Corrections)</p> <p>CSC30298 Certificate III in Correctional Practice (Community Corrections)</p> <p>CSC30398 Certificate III in Correctional Practice (Administration/Ancillary)</p>	15 February 1999
2211AWB Certificate II in Hospitality (Food and Beverage Retail Service)	19 February 1999
12280ACT Certificate II in Sport and Recreation (Traineeship) (Streams: Aquatics)	24 February 1999
<p>THT10198 Certificate I in Tourism (Aboriginal & Torres Strait Islander Cultural Guiding)</p> <p>THT20198 Certificate II in Tourism (Sales / Office Operations)</p> <p>THT20298 Certificate II in Tourism (Attractions & Theme Parks)</p> <p>THT20398 Certificate II in Tourism (Aboriginal & Torres Strait Islander Cultural Guiding)</p>	2 March 1999

<p>THT20498 Certificate II in Tourism (Guiding) THT30198 Certificate III in Tourism (Meetings & Events) THT30298 Certificate III in Tourism (Retail Travel Sales) THT30398 Certificate III in Tourism (International Retail Travel Sales) THT30498 Certificate III in Tourism (Tour Operations) THT30598 Certificate III in Tourism (Tour Wholesaling) THT30698 Certificate III in Tourism (Visitor Information Services) THT30798 Certificate III in Tourism (Attractions & Theme Parks) THT30898 Certificate III in Tourism (Aboriginal & Torres Strait Islander Cultural Guiding) THT30998 Certificate III in Tourism (Guiding)</p>	
<p>FNA20298 Certificate II in Finance (Credit Management) FNA20198 Certificate II in Finance (Retail Financial Services) FNA30398 Certificate III in Finance (Credit Management) FNA30298 Certificate III in Finance (Mercantile Agents) FNA30498 Certificate III in Finance (Personal Trust Administration) FNA30198 Certificate III in Finance (Retail Financial Services) FNA40298 Certificate IV in Finance (Credit Management/Mercantile Agents) FNA40398 Certificate IV in Finance (Personal Trust Administration) FNA40198 Certificate IV in Finance (Retail Financial Services)</p>	16 March 1999
NSW275 Certificate III in Pharmaceutical Manufacturing	18 March 1999
<p>NSW7302 Certificate III in Forest and Forest Products - Sawdoctoring NSW7302 Certificate IV in Forest and Forest Products - Sawdoctoring</p>	23 March 1999
RUH20198 Certificate II in Horticulture	23 March 1999
<p>RUH20298 Certificate II in Horticulture (Arboriculture) RUH20398 Certificate II in Horticulture (Floriculture) RUH20498 Certificate II in Horticulture (Landscape) RUH20598 Certificate II in Horticulture (Nursery) RUH20698 Certificate II in Horticulture (Parks and Gardens) RUH20798 Certificate II in Horticulture (Turf Management) RUH20898 Certificate II in Horticulture (Production) RUH30198 Certificate III in Horticulture RUH30298 Certificate III in Horticulture (Arboriculture)</p>	23 March 1999

<p>RUH30398 Certificate III in Horticulture (Floriculture) RUH30498 Certificate III in Horticulture (Landscape) RUH30598 Certificate III in Horticulture (Nursery) RUH30698 Certificate III in Horticulture (Parks and Gardens) RUH30798 Certificate III in Horticulture (Turf Management) RUH30898 Certificate III in Horticulture (Production) RUH40198 Certificate IV in Horticulture RUH40298 Certificate IV in Horticulture (Arboriculture) RUH40398 Certificate IV in Horticulture (Floriculture) RUH40498 Certificate IV in Horticulture (Landscape) RUH40598 Certificate IV in Horticulture (Nursery) RUH40698 Certificate IV in Horticulture (Parks and Gardens) RUH40798 Certificate IV in Horticulture (Turf Management) RUH40898 Certificate IV in Horticulture (Production)</p>	
<p>2301AHA Certificate III in Forest Industries (Sawmilling and Processing) 2401ACA Certificate IV in Forest Industries (Sawmilling and Processing)</p>	25 March 1999
<p>2304ADB Certificate III in Timber Merchandising (Supervision) 2304AEB Certificate III in Timber Merchandising (Management)</p>	6 April 1999
<p>15122VIC Certificate III in Forest and Forest Products (Timber Manufacturing - Estimator/Detailer)</p>	8 April 1999
<p>RUA20198 Certificate II in Agriculture RUA30198 Certificate III in Agriculture RUA40198 Certificate IV in Agriculture RUA20298 Certificate II in Agriculture (Beef Cattle Production) RUA30298 Certificate III in Agriculture (Beef Cattle Production) RUA20498 Certificate II in Agriculture (Dairy) RUA30498 Certificate III in Agriculture (Dairy) RUA40498 Certificate IV in Agriculture (Dairy) RUA20598 Certificate II in Agriculture (Goat Production) RUA30598 Certificate III in Agriculture (Goat Production) RUA20698 Certificate II in Agriculture (Grain Production) RUA30698 Certificate III in Agriculture (Grain Production) RUA20798 Certificate II in Agriculture (Horse Breeding) RUA30798 Certificate III in Agriculture (Horse Breeding) RUA20998 Certificate II in Agriculture (Pig Production) RUA30998 Certificate III in Agriculture (Pig Production) RUA21098 Certificate II in Agriculture (Poultry Production)</p>	16 April 1999

RUA31098 Certificate III in Agriculture (Poultry Production) RUA21298 Certificate II in Agriculture (Rural Merchandising) RUA31298 Certificate III in Agriculture (Rural Merchandising) RUA21398 Certificate II in Agriculture (Sheep & Wool Production) RUA31398 Certificate III in Agriculture (Sheep & Wool Production)	
---	--

Details of the approved training schemes can be obtained from the General Manager, Client Relations Management Division, Office of Training and Further Education, Department of Education, 2 Treasury Place, East Melbourne 3002. Telephone 9637 2791. Fax 9637 3220.

Road Safety Act 1986

**EXTENDING PROVISIONS TO LAND AT AUSTRALIAN SAFEWAY STORES PTY LTD
 53-65 MILITARY ROAD, AVONDALE HEIGHTS IN THE CITY OF
 MOONEE VALLEY**

I, Brian John Negus, Regional Manager - Metropolitan North West Region of the Roads Corporation, under the powers delegated to me by the Minister for Roads and Ports, and under Section 98 of the **Road Safety Act 1986**, by this Order extend the application of:

- (a) Sections 59, 64, 65, 76, 77, 85-90, 99 and 100 of that Act; and
 - (b) The Road Safety (Traffic) Regulations 1988; and
 - (c) Parts 7 and 8 and Schedules 5 and 6 of the Road Safety (Procedures) Regulations 1988 -
- to land, under the control of the City of Moonee Valley, particulars to which are shown hatched on the attached plan.

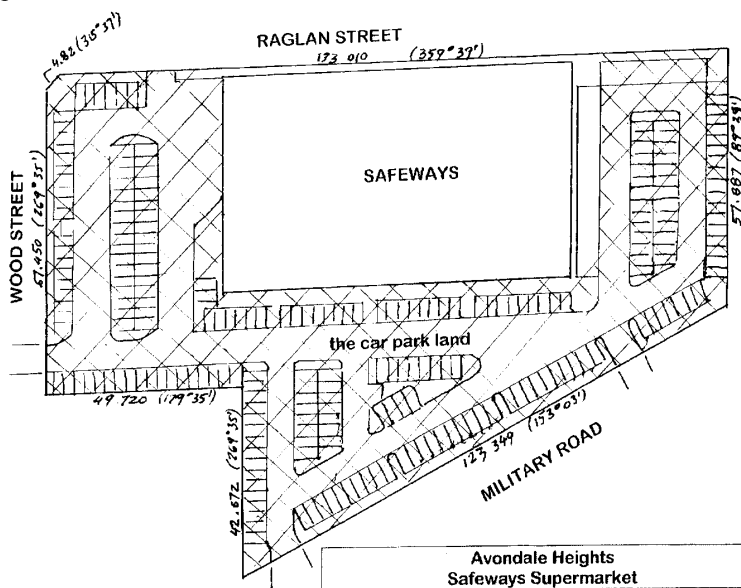

Dated 12 April 1999.

BRIAN NEGUS
 Regional Manager - Metropolitan North West
 Roads Corporation

Road Safety Act 1986ROAD SAFETY (VEHICLES)
REGULATIONS 1988

Declaration of Hazardous Areas

I, Geoff Klood, delegate of the Roads Corporation, acting under Regulation 1050 of the Road Safety (Vehicles) Regulations 1988, declare that the following areas, which in my opinion contain hazardous driving conditions for vehicles, are hazardous areas for the purposes of those Regulations for the period 1 June 1999 to 8 October 1999, both dates inclusive:

MOUNT BULLER

The Mount Buller Road from the junction of the Mount Stirling Road to the Mount Buller Alpine Village.

MOUNT HOTHAM

The Great Alpine Road from Harrietville over Mount Hotham to Omeo.

FALLS CREEK

The Bogong High Plains Road from Mount Beauty via Falls Creek to the Omeo Highway.

MOUNT BUFFALO

The road from the Department of Natural Resources and Environment control gate situated at the base of Mount Buffalo to the Horn.

MOUNT BAW BAW

The East Tanjil Bren Road from Tanjil Bren to Mount Baw Baw Alpine Village.

LAKE MOUNTAIN

The Marysville-Woods Point Road from the Lake Mountain turnoff to Cumberland Junction.

MOUNT DONNA BUANG

The Acheron Way between Cement Creek and St Fillans and the Healesville-Warburton Road from Panton Gap to the intersection of the Cement Creek-Donna Buang Summit Road.

MOUNT SAINT GWINEAR

The Thomson Valley Road from the Thomson Dam Road intersection to Rocky Knob and the Mount Saint Gwinear Road from Rocky Knob to the Mount Saint Gwinear car park.

MOUNT STIRLING

The Mount Stirling Road from the

intersection of the Mount Buller Road at Mirimbah to Telephone Box Junction.

MOUNT TORBRECK

The Mount Torbreck Road.

MOUNT TAMBORITHA

The Mount Tamboritha Road between the last crossing of the Wellington River and Mount Tamboritha.

LICOLA AREA

The Target Creek Road between Licola and Glencairn and the Jamieson/ Licola/ Heyfield Road between Licola and Violet Hill.

Dated 21/04/99

GEOFF KLOOD
General Manager
Traffic & Road Use Management
Roads Corporation

Road Safety Act 1986

MOTOR CYCLE RELIABILITY TRIAL

Under section 68(3) of the **Road Safety Act 1986**, I declare that sub-sections (1) and (2) of section 68 of the Act shall not apply with respect to the event to be known as the '99 Australian Four Day Enduro' to be conducted by the MAV Enduro Board of Management on sections of road within the Welshpool & Binginwarri Forest Districts from 13 May to 16 May 1999 between the hours of 7.00 a.m. and 5.00 p.m.

Dated 20 April 1999.

W. M. DEGNAN
Acting Regional Manager
Eastern Victoria
Delegate of the Minister
for Roads and Ports

Health Services Act 1988DECLARATION OF APPROVED QUALITY
ASSURANCE BODY

I declare the Improving Performance Committee, established by Hawthorn Private Hospital, is an approved quality assurance body under section 139 for the purposes of Part 7 of the **Health Services Act 1988**.

Dated 21 April 1999.

ROB KNOWLES
Minister for Health

Health Services Act 1988DECLARATION OF APPROVED QUALITY
ASSURANCE BODY

I declare the Quality Assurance and Accreditation Committee, established by Alpine Health, is an approved quality assurance body under section 139 for the purposes of Part 7 of the **Health Services Act 1988**.

Dated 21 April 1999.

ROB KNOWLES
Minister for Health

Health Services Act 1988DECLARATION OF APPROVED QUALITY
ASSURANCE BODY

I declare the Patient/Client Care Sub-Committee, established by Djerriwarrh Health Services is an approved quality assurance body under section 139 for the purposes of Part 7 of the **Health Services Act 1988**.

Dated 21 April 1999.

ROB KNOWLES
Minister for Health

Health Services Act 1988DECLARATION OF APPROVED QUALITY
ASSURANCE BODY

I declare the Medical Advisory Committee, established by Hawthorn Private Hospital, is an approved quality assurance body under section 139 for the purposes of Part 7 of the **Health Services Act 1988**.

Dated 21 April 1999.

ROB KNOWLES
Minister for Health

Health Services Act 1988DECLARATION OF APPROVED QUALITY
ASSURANCE BODY

I declare the Wodonga Regional Health Service (WRHS) Quality Assurance Committee established by Wodonga Regional Health Service an approved quality assurance body under section 139 for the purposes of Part 7 of the **Health Services Act 1988**.

Dated 21 April 1999.

ROB KNOWLES
Minister for Health

Subordinate Legislation Act 1994

NOTICE OF DECISION

Electricity Safety (Installations) Regulations
1999

I, Alan R. Stockdale, Treasurer and Minister responsible for the administration of **Electricity Safety Act 1998**, under Section 12 of the **Subordinate Legislation Act 1994**, give notice as follows:

A Regulatory Impact Statement (RIS) was prepared in relation to the proposed Electricity Safety (Installations) Regulations 1999 and advertised inviting public comment. 46 submissions were received in response to the RIS. I have decided that the proposed Regulations, with amendments, should be made.

Dated: 22 April 1999.

ALAN R. STOCKDALE
Treasurer

Subordinate Legislation Act 1994

NOTICE OF DECISION

Electricity Safety (Equipment) Regulations
1999

I, Alan R. Stockdale, Treasurer and Minister responsible for the administration of **Electricity Safety Act 1998**, under Section 12 of the **Subordinate Legislation Act 1994**, give notice as follows:

A Regulatory Impact Statement (RIS) was prepared in relation to the proposed Electricity Safety (Equipment) Regulations 1999 and advertised inviting public comment. 8 submissions were received in response to the RIS. I have decided that the proposed Regulations, with amendments, should be made.

Dated: 22 April 1999.

ALAN R. STOCKDALE
Treasurer

Subordinate Legislation Act 1994

NOTICE OF DECISION

Electricity Safety (Equipment Efficiency)
Regulations 1999

I, Alan R. Stockdale, Treasurer and Minister responsible for the administration of **Electricity**

Safety Act 1998, under Section 12 of the **Subordinate Legislation Act 1994**, give notice as follows:

A Regulatory Impact Statement (RIS) was prepared in relation to the proposed Electricity Safety (Equipment Efficiency) Regulations 1999 and advertised inviting public comment. 8 submissions were received in response to the RIS. I have decided that the proposed Regulations, with amendments, should be made.

Dated: 22 April 1999.

ALAN R. STOCKDALE
Treasurer

Subordinate Legislation Act 1994

NOTICE OF DECISION

Electricity Safety (Stray Current Corrosion)
Regulations 1999

I, Alan R. Stockdale, Treasurer and Minister responsible for the administration of **Electricity Safety Act 1998**, under Section 12 of the **Subordinate Legislation Act 1994**, give notice as follows:

A Regulatory Impact Statement (RIS) was prepared in relation to the proposed Electricity Safety (Stray Current Corrosion) Regulations 1999 and advertised inviting public comment. 9 submissions were received in response to the RIS. I have decided that the proposed Regulations, with amendments, should be made.

Dated: 22 April 1999.

ALAN R. STOCKDALE
Treasurer

Subordinate Legislation Act 1994

NOTICE OF DECISION

Electricity Safety (Electrical Appeals Board)
Regulations 1999

I, Alan R. Stockdale, Treasurer and Minister responsible for the administration of **Electricity Safety Act 1998**, under Section 12 of the **Subordinate Legislation Act 1994**, give notice as follows:

A Regulatory Impact Statement (RIS) was prepared in relation to the proposed Electricity Safety (Electrical Appeals Board) Regulations 1999 and advertised inviting

public comment. 4 submissions were received in response to the RIS. I have decided that the proposed Regulations, with amendments, should be made.

Dated: 22 April 1999.

ALAN R. STOCKDALE
Treasurer

Children and Young Persons Act 1989

APPOINTMENT OF HONORARY
PROBATION OFFICERS

I, Des O'Shea, Regional Director of Northern Metropolitan Region of the Department of Human Services, under Section 34 (4) of the **Children and Young Persons Act 1989** appoint the undermentioned persons as Honorary Probation Officers for the Children's Court in the State of Victoria for the period ending 31 December 2001.

Stephen Blamey, Elizabeth Brown, Gavin Alan Campbell, Jenny Louise Cramer, Harry Trevor Crowther, Trudy De Luise, Roula Dib, Milton Lee Embling, Maryanne Louise Eve, Ann-Marie D. Fife, Paul Albert Fumei, Dimitra Gianakopoulos, Snezana (Suzy) Gorcevski, Lola Natalie Grech, Lorraine Haack, April Lorraine Lee Harvey, Jonathon B. Hume, Wendy Maree Jones, Olive King, Dolores Maria Kruzynski, Karen Louise Lloyd, Rebecca J. McGowan, Ben McIntyre, Gina Mancuso, Lisa Mete, Kerryann Jannise Mulvenna, Michael O'Donnell, Joan Isobal Pollock, Kim Priscilla Purdey, Nicole Dannielle Ralph, Sadie Edith Rathbone, Sahin Sahinkaya, Abdul Rahim Samat, Brian Shearwood, Katherine Siskos, Robyn June Skerry, Daniela Tatti, Fay Patricia Treveithick, Olivia Tsolakis, Richard John Thompson, Laura Valentino, Josefa J. Vuwai, Nicole Caroline Woodhouse.

Dated 23 March 1999.

DES O'SHEA
Regional Director
Northern Metropolitan Region

Adoption Act 1984

Under the functions and powers assigned to me by the Secretary, Department of Human Services under Section 10(2) of the **Community Welfare Services Act 1970** in relation to Section 5 of the **Adoption Act 1984**.

I, Gabrielle Levine, approve the following person under Section 5 [1] and Section 5 [2] (b) of the Act as approved counsellor for the purposes of Section 35 of the Act.

Kyriaki Artis, Anglicare - Western, 41 Somerville Road, Yarraville 3013.

I, Gabrielle Levine, revoke the following person under Section 5[1] and Section 5[2] (b) of the Act as approved counsellor for the purposes of Section 35 of the Act.

Belinda Selge, Anglicare - Western, 41 Somerville Road, Yarraville 3013.

GABRIELLE LEVINE
Regional Director
Department of Human Services
Western Metropolitan Region

Adoption Act 1984

SECTIONS 21 AND 22

Application For Approval as an Adoption Agency

Under the provisions of Section 10(2) of the **Community Services Act 1970** I have been assigned the functions and powers of the Secretary of Department of Human Services under Sections 21 and 22 of the **Adoption Act 1984**.

After considering an application from the following welfare organisation, I have approved it as an "approved agency" for the purposes of conducting negotiations and making arrangements for the adoption of children, in accordance with section 22 of the **Adoption Act 1984**.

Westate Community Development Limited
175-187 Hargreaves Street,
Bendigo 3550
Principal Officer: Jennifer Hocking

This approval is for a period of three years from the date of this notice unless suspended or revoked at an earlier date.

Dated: 5 March 1999.

YEHUDI BLACHER
Director
Youth and Family Services

Water Act 1989

GRAMPIANS WATER

Proposal to Create Ouyen Sewerage District **Water Act 1989** Section 96

Notice is hereby given that the Grampians Region Water Authority proposes to create the Ouyen Sewerage District under the provision of Section 96 (7) of the **Water Act 1989**.

A copy of the plan showing the proposed Sewerage District is available for inspection free of charge, at Grampians Water's Office, 11 McLachlan Street, Horsham, during office hours. The plan is also available at the Mildura Rural City Council – Ouyen Office, Oke Street, Ouyen and the Wimmera Mallee Water District Office, 15 Pickering Street, Ouyen. The plan indicates the boundaries of the proposed new Sewerage District.

Members of the public are invited to make a submission on the proposal. Any person making a submission on the proposal should set out the grounds for any objections raised in the submission.

Submissions should be received by Grampians Water no later than 31 May 1999, which is one month after the publication of this notice in the Government Gazette. Submissions should be addressed to the Chief Executive Officer, Grampians Water, P.O. Box 481, Horsham 3402. If any submissions are received, Grampians Water will consider them at its Board meeting scheduled for 21 June 1999.

Grampians Water: 11 McLachlan Street, Horsham, Victoria 3400, P.O. Box 481 Horsham 3402. Tel: (03) 5382 4611. Fax: (03) 5381 9881.

Water Act 1989

GOULBURN VALLEY REGION WATER AUTHORITY

Section 96

Proposal to Create Violet Town Sewerage District

Notice is hereby given that Goulburn Valley Region Water Authority proposes to create the Violet Town Sewerage District.

Full details of the proposal and a copy of the plan showing the full extent of the proposed Sewerage District are available for inspection

free of charge at the offices of Goulburn Valley Region Water Authority, 104-110 Fryers Street, Shepparton, during normal office hours. The plan indicates where the proposed district is located.

Members of the public are invited to make submissions on the proposals. Any person making an objection should set out the grounds for any objection raised in the submission.

Submissions must be received by Goulburn Valley Region Water Authority by 31 May 1999 which is one month after publication of this notice in the Government Gazette, and should be addressed to Mr B. Anderson, Acting Director - Technical Services, P.O. Box 185, Shepparton 3632.

All submissions received will be considered by Goulburn Valley Water Region Water Authority at its meeting scheduled for 2 June 1999 and forwarded to the Minister for Agriculture and Resources.

LAURIE GLEESON
Chief Executive

Goulburn Valley Region Water Authority

Water Act 1989

I, Patrick McNamara, Minister for Agriculture and Resources, make the following Order:

SALE

GROUNDWATER SUPPLY PROTECTION AREA DECLARATION ORDER 1999

1. This Order is called the Sale Groundwater Supply Protection Area Declaration Order 1999.
2. This Order is made under the powers conferred by Division 3 of Part 3 of the **Water Act 1989** and all other available powers.
3. This Order takes effect on and from the date it is published in the Government Gazette.
4. On and from the date on which this Order takes effect-
 - (a) the area of land shown within the hatched border on Plan No. LGL./97-248 and the aquifers from 25 to 200 metres from the natural surface is declared to be a Groundwater Supply Protection Area; and
 - (b) the area shall be known as the Sale Groundwater Supply Protection Area.
5. Plan No. LGL./97-248 referred to in clause 4 may be inspected at the office of Land and Survey Information Services - Department of Natural Resources and Environment, 436 Lonsdale Street, Melbourne during business hours.

Dated 14 April 1999

PATRICK McNAMARA
Minister administering the **Water Act 1989**

FORM 7

S.21
Reg. 16

NOTICE OF ACQUISITION

Compulsory Acquisition of an Interest in Land

The Minister for Planning and Local Government declares that by this notice it acquires the following interest(s) in the land described as part of Crown Allotment 134A Parish of Nunawading comprising 4.316 hectares and being land described in Certificates of Title Volume 8654 Folio 975 Volume 8135 Folio 244 and Volume 7321 Folio 038 shown as Lot B on Roads Corporation Plan 423750A.

Interest Acquired: That of Laurance Thomas George Petty and Janet Margaret Petty as owners and all other interests.

Published with the authority of the Minister for Planning and Local Government.

The plan referred to in this notice may be viewed at the Office of the Property Services Department, VicRoads, 60 Denmark Street, Kew.

For and on behalf of The Minister for Planning and Environment:

Dated 29 April 1999.

T. H. HOLDEN
Manager Property Services
Department, VicRoads
(Appointed as Agent for the
Department of Infrastructure)

FINANCIAL INSTITUTIONS (VICTORIA)
CODE SECTION 342

Corporations Law Section 601AB(2)
Notice of Proposed Deregistration

Pursuant to section 601AB(2) of the Corporations Law as applied by section 342 of the Financial Institutions (Victoria) Code the Victorian Financial Institutions Commission gives notice of the proposed deregistration of **Schwaben Credit Union Co-operative Limited (In liquidation)** when 2 months have passed since publication of this notice.

Dated 26 April 1999.

Victorian Financial Institutions Commission

Gas Industry Act 1994

NOTICE OF VARIATION OF LICENCE

The Office of the Regulator-General gives notice under section 48I of the Act that -

The gas retail licence held by GASCOR has been varied by the Treasurer on 31 March 1999 in accordance with clause 18.2 of that licence. A copy of the licence as varied may be inspected during business hours at the Office of the Regulator-General, 1st Floor, 35 Spring Street, Melbourne 3000.

Dated 26 April 1999.

IAN WILSON
as delegate for
Regulator-General

Transport Act 1983

TOW TRUCK DIRECTORATE OF
VICTORIA

Tow Truck Applications

Notice is hereby given that the Licensing Authority will consider the following application/s after 2 June 1999.

Notice of any objection to the granting of an application should be forwarded to reach the Director, Tow Truck Directorate of Victoria, Level 6, 14-20 Blackwood Street, North Melbourne, P.O. Box 666, North Melbourne 3051 not later than 27 May 1999.

It will not be necessary for interested parties to appear on the date specified, unless advised in writing.

Lisio Pty Ltd. Application for variation of conditions of tow truck licence numbers TOW033 and TOW036 which authorise the

licensed vehicles to be managed, controlled and operated from a depot situated at 37 Bridge Street, Bulleen to change the depot address to 667 Waterdale Road, Heidelberg West.

Modern Towing & Salvage (Holdings) Pty Ltd. Application for variation of conditions of tow truck licence numbers TOW035, TOW045, TOW049, TOW562 and TOW700 which authorise the licensed vehicles to be managed, controlled and operated from a depot situated at 37 Bridge Street, Bulleen to change the depot address to 667 Waterdale Road, Heidelberg West.

Modern Towing & Salvage Aust. Pty Ltd. Application for variation of conditions of tow truck licence numbers TOW032 and TOW048 which authorise the licensed vehicles to be managed, controlled and operated from a depot situated at 37 Bridge Street, Bulleen to change the depot address to 667 Waterdale Road, Heidelberg West.

C. Carpenter. Application for variation of conditions of tow truck licence numbers TOW044 and TOW051 which authorise the licensed vehicles to be managed, controlled and operated from a depot situated at 37 Bridge Street, Bulleen to change the depot address to 667 Waterdale Road, Heidelberg West.

Extaris Anna Nominees Pty Ltd. Application for variation of conditions of tow truck licence number TOW785 which authorise the licensed vehicle to be managed, controlled and operated from a depot situated at 37 Bridge Street, Bulleen to change the depot address to 667 Waterdale Road, Heidelberg West.

Murrumbeena Towing Service Pty Ltd. Application for variation of conditions of tow truck licence number TOW706 which authorise the licensed vehicle to be managed, controlled and operated from a depot situated at 399 Tooronga Road, Hawthorn East to change the depot address to 13-15 Wannan Street, Highett.

H. Arnold. Application for variation of conditions of tow truck licence number TOW219 which authorise the licensed vehicle to be managed, controlled and operated from a depot situated at 2 Cowslip Street, Violet Town to change the depot address to Lot 3 Lowens Lane, Benalla.

Dated 29 April 1999.

TERRY O'KEEFE
Director

Witness Protection Act 1991

GOVERNMENT OF VICTORIA

I, Bill McGrath, Minister for Police and Emergency Services and Minister administering the **Witness Protection Act 1991**, acting under section 3 of the **Witness Protection Act 1991**, declare the **Witness Protection Act 1996** of the State of South Australia, being a law that makes provision for the protection of witnesses, to be a complementary witness protection law for the purposes of the **Witness Protection Act 1991**.

Dated 4 April 1999.

BILL McGRATH
Minister for Police and
Emergency Services

Victoria Racing Club Act 1871

NOTICE OF AMENDMENT OF BY-LAW 51

Notice is given that the Committee of the Victoria Racing Club pursuant to Section 14 of the **Victoria Racing Club Act 1871**, at a meeting held on 18 December 1998, resolved that By-Law 51 which provides for tolls and charges which may be levied and taken for admission to areas or divisions of Flemington Racecourse be amended as follows:

- (a) On Derby Day for '\$20.00' substitute '\$22.00'
- (b) On Melbourne Cup Day for '\$23.00' substitute '\$25.00'
- (c) On Oaks Day for '\$20.00' substitute '\$22.00'
- (d) On Final Day for '\$10.00' substitute '\$12.00'

A copy of this amendment to By-Law 51 was sent to the Minister for Sport on 10 March 1999, has been reviewed and has not been disallowed.

This amendment to By-Law 51 will come into operation on the date of publication of this notice in the Victoria Government Gazette.

(This notice replaces the notice which appeared in Issue G11 of the Victoria Government Gazette dated 18 March 1999, page 684).

ANDREW RAMSDEN
Chairman
Victoria Racing Club

Stamps Act 1958

NOTICE UNDER SECTION 40A

Pursuant to section 40A of the **Stamps Act 1958** I hereby declare and make effective from 16 April 1999, that:

AP - 388 – Howie & Maher

be an "Authorised Person" in relation to the stamping of Transfers of Land, Mortgages, Bonds, Debentures or Covenants, Marketable Securities, Leases, Agreements to Lease, Assignments or Transfers of Lease and Instruments of Settlement.

Dated Thursday 15 April 1999.

DAVID POLLARD
Commissioner of State Revenue

Stamps Act 1958

NOTICE UNDER SECTION 40A

Pursuant to section 40A of the **Stamps Act 1958** I hereby declare and make effective from 16 April 1999, that:

AP - 389 – Gary William Biggs trading as Biggs & Co

be an "Authorised Person" in relation to the stamping of Transfers of Land, Mortgages, Bonds, Debentures or Covenants, Marketable Securities, Leases, Agreements to Lease, Assignments or Transfers of Lease and Instruments of Settlement.

Dated Thursday 15 April 1999.

DAVID POLLARD
Commissioner of State Revenue

Stamps Act 1958

NOTICE UNDER SECTION 40A

Pursuant to section 40A of the **Stamps Act 1958** I hereby declare and make effective from 16 April 1999, that:

AP - 390 – Wakeham Investments Pty Ltd trading as Law Office Services

be an "Authorised Person" in relation to the stamping of Transfers of Land, Mortgages, Bonds, Debentures or Covenants, Marketable Securities, Leases, Agreements to Lease, Assignments or Transfers of Lease and Instruments of Settlement.

Dated Thursday 15 April 1999.

DAVID POLLARD
Commissioner of State Revenue

Stamps Act 1958

NOTICE UNDER SECTION 40A

Pursuant to section 40A of the **Stamps Act 1958** I hereby declare and make effective from 16 April 1999, that:

AP - 391 – Vincent Crisapulli trading as N. C. Gay & Co and Victorian Legal Conveyancing

be an "Authorised Person" in relation to the stamping of Transfers of Land, Mortgages, Bonds, Debentures or Covenants, Marketable Securities, Leases, Agreements to Lease, Assignments or Transfers of Lease and Instruments of Settlement.

Dated Thursday 15 April 1999.

DAVID POLLARD
Commissioner of State Revenue

Stamps Act 1958

NOTICE UNDER SECTION 40A

Pursuant to section 40A of the **Stamps Act 1958** I hereby declare and make effective from 16 April 1999, that:

AP - 392 – Basil Ristevski trading as Ristevski Horan

be an "Authorised Person" in relation to the stamping of Transfers of Land, Mortgages, Bonds, Debentures or Covenants, Marketable Securities, Leases, Agreements to Lease, Assignments or Transfers of Lease and Instruments of Settlement.

Dated Thursday 15 April 1999.

DAVID POLLARD
Commissioner of State Revenue

Stamps Act 1958

NOTICE UNDER SECTION 40A

Pursuant to section 40A of the **Stamps Act 1958** I hereby declare and make effective from 16 April 1999, that:

AP - 393 – David Rocallan Messenger

be an "Authorised Person" in relation to the stamping of Transfers of Land, Mortgages, Bonds, Debentures or Covenants, Marketable Securities, Leases, Agreements to Lease, Assignments or Transfers of Lease and Instruments of Settlement.

Dated Thursday 15 April 1999.

DAVID POLLARD
Commissioner of State Revenue

Stamps Act 1958

NOTICE UNDER SECTION 40A

Pursuant to section 40A of the **Stamps Act 1958** I hereby declare and make effective from 16 April 1999, that:

AP - 394 – Toni Nigro & Associates

be an "Authorised Person" in relation to the stamping of Transfers of Land, Mortgages, Bonds, Debentures or Covenants, Marketable Securities, Leases, Agreements to Lease, Assignments or Transfers of Lease and Instruments of Settlement.

Dated Thursday 15 April 1999.

DAVID POLLARD
Commissioner of State Revenue

Stamps Act 1958

NOTICE UNDER SECTION 40A

Pursuant to section 40A of the **Stamps Act 1958** I hereby declare and make effective from 16 April 1999, that:

AP - 395 – Michael Paul Buccheri

be an "Authorised Person" in relation to the stamping of Transfers of Land, Mortgages, Bonds, Debentures or Covenants, Marketable Securities, Leases, Agreements to Lease, Assignments or Transfers of Lease and Instruments of Settlement.

Dated Thursday 15 April 1999.

DAVID POLLARD
Commissioner of State Revenue

Stamps Act 1958

NOTICE UNDER SECTION 40A

Pursuant to section 40A of the **Stamps Act 1958** I hereby declare and make effective from 16 April 1999, that:

AP - 396 – Robert Frederick

be an "Authorised Person" in relation to the stamping of Transfers of Land, Mortgages, Bonds, Debentures or Covenants, Marketable Securities, Leases, Agreements to Lease, Assignments or Transfers of Lease and Instruments of Settlement.

Dated Thursday 15 April 1999.

DAVID POLLARD
Commissioner of State Revenue

Stamps Act 1958

NOTICE UNDER SECTION 40A

Pursuant to section 40A of the **Stamps Act 1958** I hereby declare and make effective from 16 April 1999, that:

AP - 397 – Neil Johnson & Associates

be an “Authorised Person” in relation to the stamping of Transfers of Land, Mortgages, Bonds, Debentures or Covenants, Marketable Securities, Leases, Agreements to Lease, Assignments or Transfers of Lease and Instruments of Settlement.

Dated Thursday 15 April 1999.

DAVID POLLARD
Commissioner of State Revenue

Stamps Act 1958

NOTICE UNDER SECTION 40A

Pursuant to section 40A of the **Stamps Act 1958** I hereby declare and make effective from 16 April 1999, that:

AP - 398 – Campbell Macauley

be an “Authorised Person” in relation to the stamping of Transfers of Land, Mortgages, Bonds, Debentures or Covenants, Marketable Securities, Leases, Agreements to Lease, Assignments or Transfers of Lease and Instruments of Settlement.

Dated Thursday 15 April 1999.

DAVID POLLARD
Commissioner of State Revenue

Planning and Environment Act 1987

ALL VICTORIAN PLANNING SCHEMES

Notice of Approval of Amendment

Amendment S74

The Minister for Planning and Local Government has approved Amendment S74 to all Victorian Planning Schemes.

The Amendment comes into operation on the date this notice is published in the Government Gazette.

The Amendment makes changes to Clause 7-1.4 Subdivision (Public Open Space) to the State Section of all Planning Schemes in Victoria by substituting all reference in Clause 7-1.4 to “residential buildings” with “buildings used for residential purposes” and ensures that

any reference to “the building” relates to a building used for residential purposes. The building must exist or be approved for residential use immediately before 30 October 1989.

A copy of the Amendment can be inspected, free of charge, during office hours, at the Department of Infrastructure, Customer Service Centre, Upper Plaza, Nauru House, 80 Collins Street, Melbourne and at all municipal offices in Victoria.

LEIGH PHILLIPS
Director, Planning Operations
Planning, Heritage
and Market Information
Department of Infrastructure

Planning and Environment Act 1987

BAIRNSDALE (CITY) PLANNING SCHEME

Notice of Approval of Amendment

Amendment L45

The Minister for Planning and Local Government has approved Amendment L45 to the Bairnsdale (City) Planning Scheme.

The Amendment comes into operation on the date this notice is published in the Government Gazette.

The Amendment rezones 2.004 hectares at Lot 1 LP 323053 Vol 10134 Folio 261 south side of Bosworth Road, Bairnsdale from “Rural (General Purposes)” to State Section “Industrial 1 Zone”.

A copy of the Amendment can be inspected, free of charge, during office hours, at the Department of Infrastructure, Customer Service Centre, Upper Plaza, Nauru House, 80 Collins Street, Melbourne and at the offices of the East Gippsland Shire Council, 55 Palmers Road, Lakes Entrance.

LEIGH PHILLIPS
Director, Planning Operations
Planning, Heritage
and Market Information
Department of Infrastructure

Planning and Environment Act 1987

BERWICK PLANNING SCHEME

Notice of Approval of Amendment

Amendment L143

The Minister for Planning and Local Government has approved Amendment L143 to the Berwick Planning Scheme.

The Amendment comes into operation on the date this notice is published in the Government Gazette.

The Amendment inserts a site specific control into the Berwick Residential-Normal Density zone to enable land described as Lot 80, PS111394 (747) Princes Highway, Berwick to be used for an office, training and amenity facility, subject to the grant of a permit.

A copy of the Amendment can be inspected, free of charge, during office hours, at the Department of Infrastructure, Customer Service Centre, Upper Plaza, Nauru House, 80 Collins Street, Melbourne and at the offices of the Casey City Council, Princes Highway, Narre Warren.

LEIGH PHILLIPS
Director, Planning Operations
Planning, Heritage
and Market Information
Department of Infrastructure

Planning and Environment Act 1987
BOROONDARA PLANNING SCHEME
Notice of Approval of Amendment
Amendment L51

The Minister for Planning and Local Government has approved Amendment L51 to the Boroondara Planning Scheme.

The Amendment comes into operation on the date this notice is published in the Government Gazette.

The Amendment rezones part of the Murdoch Street Reserve, Camberwell, from Public Open Space Reservation to a Camberwell Residential Zone to allow the area to be consolidated with the adjoining residential properties. The residual reserve area will be developed as a linear strip of open space. The future development of the new consolidated lots will be restricted, a Section 173 Agreement will be attached to each title. A Potentially Contaminated Overlay will be inserted over the land formerly used as a nursery.

A copy of the Amendment can be inspected, free of charge, during office hours, at the Department of Infrastructure, Customer Service Centre, Upper Plaza, Nauru House, 80 Collins Street, Melbourne and at the offices of the

Boroondara City Council, Camberwell Office,
8 Inglesby Road, Camberwell, Victoria.

LEIGH PHILLIPS
Director, Planning Operations
Planning, Heritage
and Market Information
Department of Infrastructure

Planning and Environment Act 1987
KNOX PLANNING SCHEME
Notice of Approval of Amendment
Amendment L182

The Minister for Planning and Local Government has approved Amendment L182 to the Knox Planning Scheme.

The Amendment comes into operation on the date this notice is published in the Government Gazette.

The Amendment deletes a Potentially Contaminated Land Overlay on land known as part of Lot 1, PS 423795W (formerly known as part of Lot 2 PS219235S) Police Road, Rowville.

A copy of the Amendment can be inspected, free of charge, during office hours, at the Department of Infrastructure, Customer Service Centre, Upper Plaza, Nauru House, 80 Collins Street, Melbourne and at the offices of the Knox City Council, 511 Burwood Highway, Wantirna South.

LEIGH PHILLIPS
Director, Planning Operations
Planning, Heritage
and Market Information
Department of Infrastructure

Planning and Environment Act 1987
SHERBROOKE PLANNING SCHEME
Notice of Approval of Amendment
Amendment L137

The Minister for Planning and Local Government has approved Amendment L137 to the Sherbrooke Planning Scheme.

The Amendment comes into operation on the date this notice is published in the Government Gazette.

The Amendment introduces site specific controls into the Sherbrooke Planning Scheme which includes land described as Lot 1 on LP

26129, 1 Mary Street, Emerald in the Sites of Local Significance Overlay.

A copy of the Amendment can be inspected, free of charge, during office hours, at the Department of Infrastructure, Customer Service Centre, Upper Plaza, Nauru House, 80 Collins Street, Melbourne and at the offices of the Pakenham Shire Council, Henty Way, Pakenham.

LEIGH PHILLIPS
Director, Planning Operations
Planning, Heritage
and Market Information
Department of Infrastructure

ORDERS IN COUNCIL

Cemeteries Act 1958

SCALE OF FEES

Under Section 17(1) of the **Cemeteries Act 1958**, and on the recommendation of the Minister for Health, the Governor-in-Council consents to the making of the Scales of Fees in respect of the following Public Cemeteries:

Bowman's Forest
Crib Point
Lorne
Murtoa
Stanley
Truganina
Werribee

Cemeteries Act 1958

SCALE OF FEES

By resolution of the Trust, the following fees will apply in the Bowman's Forest Public Cemetery from the date of approval by the Governor in Council. All other fees are rescinded to the extent to which they conflict with this scale.

GRAVES	\$
Land, 2.44 m X 1.22 m	70.00
DIGGING OF GRAVES	
Contract rates apply	
NICHE WALL	
Cost of Plaques plus 100%	
Pre booking of space in wall	50.00
When space used this charge is deducted from final costs	
INTERMENT FEE	
Permission to erect a headstone or monument	5% of cost
Interment of ashes in a grave	50.00
Exhumation fee	1,000.00
Search fee	10.00

DONALD GEORGE WITHEROW, trustee
ALEXANDER BRUCE WITHEROW, trustee
JOSEPH O'CONNOR, trustee

Cemeteries Act 1958

SCALE OF FEES

By resolution of the Trust, the following fees will apply in the Crib Point Public Cemetery from the date of approval by the Governor in Council. All other fees are rescinded to the extent to which they conflict with this scale.

	\$
Authorised Exhumation	900.00
	ROGER STANLEY, trustee
	CLEMENTS BENNO KLEINIG, trustee
	DOUGLAS C. LANDY, trustee

Cemeteries Act 1958

SCALE OF FEES

By resolution of the Trust, the following fees will apply in the Lorne Public Cemetery from the date of approval by the Governor in Council. All other fees are rescinded to the extent to which they conflict with this scale.

NICHE WALL	\$
Single Position	400.00
BRONZE PLAQUE	
285 mm x 210 mm	175.00
NICHE WALL	
Double Position	600.00
BRONZE PLAQUE	
285 mm x 210 mm	175.00

J. D. STIRLING, trustee
G. HENDERSON, trustee
W. GRANT, trustee
A. G. PRICE, trustee
E. NORTON, trustee
EVA M. NORTON, trustee

Cemeteries Act 1958

SCALE OF FEES

By resolution of the Trust, the following fees will apply in the Murtoa Public Cemetery from the date of approval by the Governor in Council. All other fees are rescinded to the extent to which they conflict with this scale.

SINKING CHARGES FOR PRIVATE GRAVES	\$
Grave 2.44 m X 1.22 m	250.00 (plus 10% for trust supervision)
Re-opening Grave (second interment)	250.00 (plus 10% for trust supervision)
Fee for first interment	100.00
Fee for second interment	50.00

JAMES D. HAMILTON, trustee
LINDSEY L. SCHODDE, trustee
ROBERT A. GERDTZ, trustee

Cemeteries Act 1958**SCALE OF FEES**

By resolution of the Trust, the following fees will apply in the Stanley Public Cemetery from the date of approval by the Governor in Council. All other fees are rescinded to the extent to which they conflict with this scale.

LAND		\$
2.44 metres x 1.22 metres		160.00
Sinking grave 1.83 metres depth		330.00
Interment fee		70.00
Re-opening of grave — No cover		300.00
Re-opening of grave — with cover		320.00
Permission to erect a Headstone or Monument	5% of cost with a minimum of 40.00	
Exhumation charge when authorized		675.00
Search fee request		25.00

GEOFFREY FRANCIS CRAIG, trustee
CHRISTOPHER HICKS, trustee
RONALD GEORGE LEARY, trustee

Cemeteries Act 1958**SCALE OF FEES**

By resolution of the Trust, the following fees will apply in the Truganina Public Cemetery from the date of approval by the Governor in Council. All other fees are rescinded to the extent to which they conflict with this scale.

TRADITIONAL EARTH GRAVES		\$
Plot at need/pre-need		900.00
Interment fee		200.00
Sinking of grave (up to 2.13 m)		560.00
	TOTAL	1660.00
RE-OPEN GRAVE		
Re-open grave		560.00
Interment fee		200.00
	TOTAL	760.00
MISCELLANEOUS CHARGES		
Certificate of "Right of Burial" (upon request)		25.00
Interment outside prescribed hours/weekends/public holidays		300.00
Cancellation fee (pre need/at need)		90.00
Oversize (coffin or casket)		90.00
Extra depth (to allow for a third interment)		120.00
Exhumation fee		2,800.00
Ashes interred in private grave		110.00
Permission for additional inscription (Traditional Section)	10% of contract price	
Permission to erect monument or headstone (Traditional Section)	10% of overall contract price	

SHANE BOURKE J.P., trustee
GARY IMPSON, trustee
PETER ROSS, trustee

Cemeteries Act 1958
SCALE OF FEES

By resolution of the Trust, the following fees will apply in the Werribee Public Cemetery from the date of approval by the Governor in Council. All other fees are rescinded to the extent to which they conflict with this scale.

TRADITIONAL & LAWN GRAVES (Earth Graves)	\$
Plot at need & pre-need	900.00
Interment fee	200.00
Sinking of grave to 2.13 m depth	560.00
TOTAL	1,660.00
RE-OPEN GRAVE (TRADITIONAL OR LAWN)	
Re-open grave (to 2.13 m depth)	560.00
Interment fee	200.00
TOTAL	760.00
VAULTS (Concrete Lined Grave)	
Vault at need & pre-need	4,170.00
Interment fee	200.00
Sealing of Vault	310.00
TOTAL	4,680.00
RE-OPENING OF VAULT	
Re-open of Vault	450.00
Interment Fee	200.00
Sealing of Vault	310.00
TOTAL	960.00
ROSE GARDEN MEMORIAL (Rose Gardens A-G)	
Plot at need & pre-need	420.00
Interment of Cremated remains	50.00
TOTAL	470.00
ROSE GARDEN MEMORIAL (Rose Garden H - Weeping Tree)	
Plot at need & pre-need	500.00
Interment of Cremated remains	50.00
TOTAL	550.00
BABY SECTION	
Plot at need	220.00
Sinking of Grave	70.00
TOTAL	290.00
NICHE WALL MEMORIAL	
Plot at need & pre-need	310.00
Interment of cremated remains	50.00
TOTAL	360.00
MISCELLANEOUS/EXTRA CHARGES	
Certificate of "Right of Burial" (upon request)	25.00
Interment outside prescribed hours/weekends/public holidays	300.00
Cancellation fee (pre-need/at need)	90.00
Oversize (coffin or casket)	90.00
Extra depth (to allow for a third interment)	120.00
Exhumation Fee	2,800.00

Ashes interred in Private Grave (Traditional or Lawn)	110.00
Attendance at interment of cremated remains	50.00
Permission for additional inscription (Traditional Section)	10% of contract price
Permission to erect monument or headstone (Traditional Section)	10% of overall contract price
Collection of ashes (Upon request)	25.00
Selection of own grave	50.00
BRONZE PLAQUES	
Baby Memorial Plate (Communal)	60.00
Book of Life Plaque	500.00
Book of Life – additional page	250.00
Bronze Glen Vase (Lawn & Baby Sections)	115.00
Ceramic Photo Black & White 5 x 7 cm	140.00
Ceramic Photo Colour 5 x 7 cm	180.00
Detachable Plate (Lawn Section)	115.00
Dual Plaque (Lawn Section)	385.00
Niche Plate (Baby)	115.00
Niche Plate (Niche Wall)	115.00
Plaque Emblems/Motifs (each)	25.00
Rose Garden Memorial Plaque 4.5 x 5.5 (Rose Garden D-H)	150.00
Rose Garden Memorial Plaque 6 x 8 (Rose Gardens A-C)	175.00
Single Plaque (Lawn Section)	330.00
Teddy Bear Plaque	150.00
Wall Vase Niche Wall (Optional)	25.00
Reserved Plaque (Rose Garden A-H & Lawn Sections)	105.00
RAN, AIF, RAAF Emblem	30.00

SHANE BOURKE J.P., trustee

GARY IMPSON, trustee

PETER ROSS, trustee

Dated 28 April 1999.

Responsible Minister:
ROB KNOWLES
Minister for Health

BILL ZISIMOPOULOS
Acting Clerk of the Executive Council

Electricity Safety Act 1998

DECLARATION UNDER SECTION 4

Order In Council

The Governor in Council under section 4 of the **Electricity Safety Act 1998** declares that such of the provisions of this Act specified in this Order do not have effect to such extent as is specified -

Part 1

Section 4(1)(a) of the Electricity Safety Act 1998

Electrical contractors and electrical workers

1. Sections 30 and 36 of the Act do not have effect in relation to an **electrical contractor** engaged in contracts relating to -
 - (a) design, building, construction, renovation or maintenance in the building and construction industry; or
 - (b) the supply of electrical equipment

where as part of the contract the contractor sub-lets the contract to a registered electrical contractor.

2. Sections 30 and 36 of the Act do not have effect in relation to an **electrical contractor** if he or she contracts or undertakes to carry out the following electrical installation work -
 - (a) work carried out by a licensed electrician from time to time for no financial profit and on gratuitous basis on condition that prior to the commencement of the work the contractor advises the person for whom the work will be carried out that he or she is not a registered electrical contractor and does not hold the prescribed insurance;
 - (b) work at premises which the contractor occupies for residential purposes carried out by the contractor under the conditions of his or her licence under section 38(a) of the Act to carry out the electrical installation work at those premises;
 - (c) work permitted under a disconnect/reconnect worker's licence under regulation **[305]** of the Electricity Safety (Installations) Regulations 1999;
 - (d) work that involves the repair or maintenance of an electrical installation following disconnection under a disconnect/reconnect worker's licence under regulations **[305]** of the Electricity Safety (Installations) Regulations 1999;
 - (e) work that involves the installation or alteration of a cold-cathode illumination system from or commencing at the control panel or terminals of the equipment or at the transformer at which the final subcircuit which supplies the equipment terminates but does not include any part of the wiring of the final subcircuit which supplies the relevant equipment or transformer.
3. Sections 36 and 38(a) of the Act do not have effect in relation to an **electrical installation worker** if he or she carries out the following electrical installation work -
 - (a) work under the effective supervision of a licensed electrician within the period of 3 months from completion of an apprenticeship in that class of electrical work under section 39 of the Act;
 - (b) work under the effective supervision of a licensed electrician during the course of a contract of training, an examination or assessment but other than permanent electrical installation work;
 - (c) work on low voltage fixed electrical equipment, except cold-cathode illumination systems and wiring of final subcircuits, that involves the repair or maintenance of the electrical equipment or a component of that electrical equipment following disconnection of the equipment on condition that disconnection and reconnection of the equipment is carried out by a person holding a disconnect/reconnect worker's licence for that electrical equipment under regulation **[305]** of the Electricity Safety (Installations) Regulations 1999.
4. (a) Sections 36 and 38(a) of the Act do not have effect in relation to an **electrical installation worker** if he or she carries out the following electrical installation work and is certified in accordance with paragraph (b) -
 - (i) work carried out by a person who has satisfactorily completed a course or practical assessment in cold-cathode illumination systems that involves the installation of a cold-cathode illumination system from or commencing at the control panel or terminals of the equipment or at the transformer at which the final subcircuit which supplies the equipment terminates in accordance with Australian/New Zealand Standard, 'Electrical installations- Cold-cathode illumination systems', AS/NZS 3832:1998, but does not include any part of the wiring of the final subcircuit which supplies relevant equipment or transformer; or
 - (ii) work carried out by a person who has satisfactorily completed a course or practical assessment in cold-cathode illumination systems that involves the alteration, repair or maintenance of a cold-cathode illumination system in accordance with

Australian/New Zealand Standard, 'Electrical installations- Cold-cathode illumination systems', AS/NZS 3832:1998, following disconnection of the system on condition that disconnection and reconnection of the system is carried out by a person holding a disconnect/reconnect worker's licence for that electrical equipment under regulation [305] of the Electricity Safety (Installations) Regulations 1999 but does not include any part of the wiring of the final subcircuit.

- (b) An employer of a person referred to in paragraph (a) may certify that the person is competent to perform the relevant work, if the employer is satisfied that the person -
- (i) possesses the qualifications, proficiency and experience to enable that person to perform that work; and
 - (ii) has been properly trained in the safety aspects and limitations in relation to that work.
5. (a) Sections 36 and 38(a) of the Act do not have effect in relation to an **electrical installation worker** if he or she carries out the following electrical installation work and is certified in accordance with paragraph (b) -
- (i) work on electrical equipment that is used as part of a railway or tramway system within the meaning of section 93(1) of the **Transport Act 1983** or for signalling purposes within such a system;
 - (ii) work carried out under the effective supervision of a licensed electrician by a person who has completed a contract of training as an electric lineworker that involves -
 - A. the repair or replacement, for the purpose of maintenance of restoring electricity supply to a consumer, of apparatus installed at the junction between an electricity supplier's conductors and a consumer's conductors or on a panel provided solely for an electricity supplier's metering and control equipment; or
 - B. electrical installation work on outdoor lighting that has been installed for the safety of the general public on land controlled by a government department, municipal council or body established for a public purpose by an Act of Parliament of Victoria or the Commonwealth; or
 - C. electrical installation work on high voltage aerial and underground electric lines in an electrical installation and associated substations and equipment; or
 - D. electrical installation work on low voltage aerial electric lines in an electrical installation and associated equipment installed for the control or protection of those lines; or
 - E. electrical installation work comprising the jointing of underground wiring; or
 - (iii) work carried out under the effective supervision of a licensed electrician by a person who has completed a contract of training as an electrical fitter at a substation in an electrical installation; or
 - (iv) work on wiring supports and enclosures under the effective supervision of a licensed electrician; or
 - (v) telecommunications work by a telecommunications worker.
- (b) An employer of a person referred to in paragraph (a) or a licensed electrician may certify that the employee or person is competent to perform the relevant work, if the employer or electrician is satisfied that the person -
- (i) possesses the qualifications, proficiency and experience to enable that person to perform that work;
 - (ii) has been properly trained in the safety aspects and limitations in relation to that work.
6. Section 38(b) of the Act does not have effect in relation to an **electrical inspector** if he or she carries out electrical inspection work under the effective supervision of a licensed electrician or licensed electrical inspector during the course of a contract of training, an examination or assessment but other than inspection work for the purposes of section 45 of the Act.

7. Section 38(b) of the Act does not have effect in relation to an **electrical inspector** if he or she carries out testing or inspection of electrical equipment that is not related to the carrying out or completion installation work.

Part 2

Section 4(1)(b) of the Electricity Safety Act 1998

Electrical equipment

1. Divisions 1, 2 and 3 (with the exception of section 43) of Part 3 of the Act do not have effect in relation to the following **electrical installations** -
Electrical installations -
 - (a) upstream of the point of supply except electrical installations used for the consumption of electricity by the electricity supplier;
 - (b) comprising of connections to consumers terminals for the purpose of providing electricity supply;
 - (c) owned by an electricity supplier for metering or the control or protection of metered or metering circuits;
 - (d) used in the operation of mining under licence within the meaning of the **Mineral Resources Development Act 1990**;
 - (e) comprising of fixed electrical equipment designed to be easily transportable connected to the electricity supply by the insertion of a plug into a socket designed for such a plug;
 - (f) used in a cathodic protection system or a mitigation system.
2. Sections 54 and 57(1) of the Act do not have effect in relation to the supply of second hand **electrical equipment** on condition that -
 - (a) the electrical equipment is not subject to a withdrawal of approval or a prohibition of supply or a recall of electrical equipment by the Office or by a prescribed authority under Part 4 of the Act or subject to a direction under section 141 of the Act; and
 - (b) the person supplying the second hand equipment in the course of business ensures that -
 - (i) the equipment on inspection and testing complies with Australian/New Zealand Standard, 'In-service safety inspection and testing of electrical equipment', AS/NZS 3760:1996, and is labelled to show compliance; or
 - (ii) the equipment is clearly marked "**DANGER - DO NOT USE OR CONNECT TO SUPPLY - THIS ELECTRICAL EQUIPMENT MAY BE FAULTY AND SHOULD BE INSPECTED AND TESTED BY A COMPETENT PERSON IN ACCORDANCE WITH AS 3760**"; and
 - (iii) a label is attached to the equipment stating that the equipment is second hand.
3. Sections 54 and 57(1) of the Act do not have effect in relation to the supply of second hand **electrical equipment** on condition that the person supplying the second hand equipment -
 - (a) is not supplying the equipment in the course of business; and
 - (b) ensures that a label is attached to the equipment stating that the equipment is second hand.
4. Section 68(1) of the Act does not have effect in relation to the supply of the following proclaimed **electrical equipment** manufactured or imported prior to 30 September 1999 for the period from 1 October 1999 to 30 September 2000 -
 - (a) refrigerating appliances registered or deemed to be registered under the Electricity Safety (Equipment Efficiency) Regulations 1999 until 30 September 1999 which do not comply with with the minimum energy performance standards set out in clause 3.5 of Australian/New Zealand Standard, 'Performance of household electrical appliances - Refrigerating appliances - Part 2: Energy labelling and minimum energy performance standard requirements, AS/NZS 4474.2:1997, on condition that the appliances are labelled in accordance with that expired registration; and

- (b) storage water heaters - unvented without an attached feed tank which do not comply with the minimum energy requirements set out in clause 2.4 of Australian Standard, 'Storage water heaters - Part 1: General Requirements', AS 1056.1:1991.

Part 3

Section 4(1)(c) of the Electricity Safety Act 1998

Electrical work

Divisions 1, 2 and 3 (with the exception of section 43) of Part 3 of the Act do not have effect in relation to the following electrical installation work -

Electrical installation work -

- (a) on any electrical installation in the process of manufacture at a place other than the land where it is to be fixed;
- (b) on any electrical installation in the course of repair or maintenance at a place other than the land where it is to be fixed;
- (c) involving the insertion or removal of -
- (i) a plug into or from a socket designed for such a plug; or
 - (ii) a light globe, fluorescent tube or starter for a fluorescent tube, where access to live parts is not required; or
 - (iii) a fuse element.
- (d) involving the installation or removal of listening devices or radio frequency transmission equipment carried out by a serving member of the Victorian Police Force who has satisfactorily completed a training course approved by the Office and in conjunction with a warrant granted under the **Listening Devices Act 1969**.

Except where expressions are defined in the Act, expressions used in this Order have the same meaning as they have in the **Electricity Safety (Installations) Regulations 1999**.

This Order is effective from 3 May 1999.

Dated 28 April 1999.

Responsible Minister:
ALAN R. STOCKDALE
Treasurer

BILL ZISIMOPOULOS
Acting Clerk of the Executive Council

Electricity Safety Act 1998

ORDER IN COUNCIL

Proclamation of Certain Classes, Description or Types of Electrical Equipment

PART 1

The Governor in Council under Section 67 of the **Electricity Safety Act 1998** revokes the two Orders under section 57(1) of the **State Electricity Commission Act 1958** entitled "Declaration of Certain Electrical Appliances to be Proclaimed Electrical Appliances" dated 19 December 1989 and 21 January 1992 deemed to be Orders under section 67 of the **Electricity Safety Act 1998**, and declares the following class, description or type of electrical

equipment, listed below, to be proclaimed electrical equipment from 3 May 1999:

1. "**Rotary clothes dryer**" - an electrical appliance which -
 - (a) is a household type; and
 - (b) is designed for drying water-washed clothes and other textile materials while those clothes and materials are caused to tumble freely.
2. "**Clothes washing machine**" - an electrical appliance which -
 - (a) is a household type; and
 - (b) is intended for washing clothes and other textile materials.

3. **“Refrigerating appliance”** - an electrical appliance which -
- is a household type;
 - operates on the vapour compression principle; and
 - cools and stores food.
4. **“Dishwasher”** - an electrical appliance which -
- is a household type; and
 - is for washing of eating and cooking utensils.
5. **“Room airconditioner”** - an electrical appliance which -
- is designed for connection to low voltage single phase supply;
 - operates on the vapour compression principle;
 - has a rated cooling capacity of up to 7.5 kW;
 - is of the non-ducted type; and
 - has a single refrigeration circuit with one evaporator and one condenser.

PART 2

The Governor in Council under section 67 of the **Electrical Safety Act 1998** declares the following class, description or type of electrical equipment, listed below, to be proclaimed electrical equipment from 1 October 1999.

1. **“Storage water heater”** - an electrical appliance which -
- is an un-vented displacement storage type;
 - has heating units of the tubular-sheathed immersion or bobbin type; and
 - has a rated hot-water delivery within the range 25 litre to 630 litre as determined in accordance with Australian Standard, ‘Storage water heaters - Part 1: General requirements’ AS1056.1-1991.

Dated 28 April 1999.

Responsible Minister:
ALAN R. STOCKDALE
Treasurer

BILL ZISIMOPOULOS
Acting Clerk of the Executive Council

Gas Industry Act 1994

ORDER UNDER SECTION 48C

Order in Council

- The Governor in Council acting under Section 48C of the **Gas Industry Act 1994** (the “Act”) exempts Gas Release Co Pty Ltd, A.C.N. 079 089 286 from the requirement to obtain a licence under Section 48B(2) of the Act in respect of the sale of gas by retail to a Relevant Company.
- For the purpose of this Order a “Relevant Company” means Generation Victoria (being the statutory corporation of that name established under the **Electricity Industry Act 1993**), any body corporate which acquires all or substantially all of the electricity generation assets of Generation Victoria or any successor or assign of that body corporate.
- This Order comes into force on 20 April 1999 and continues until 31 December 2003 unless revoked or extended.

Dated 20 April 1999.

Responsible Minister:
ALAN R. STOCKDALE
Treasurer

BILL ZISIMOPOULOS
Acting Clerk of the Executive Council

Chattel Securities Act 1987

DECLARATION CONCERNING SOUTH AUSTRALIA

Order in Council

The Governor in Council, acting under section 3(8) of the **Chattel Securities Act 1987**, by this Order declares that:

- South Australia is a recognised State; and
- the provisions of the **Goods Securities Act 1986** of South Australia and the regulations under that Act are a corresponding law; and
- prescribed goods within the meaning of the **Goods Securities Act 1986** of South Australia are interstate registrable goods; and
- the South Australian Department of Transport is a corresponding Authority.

Dated 28 April 1999.

Responsible Minister:
GEOFF CRAIGE
Minister for Roads and Ports

BILL ZISIMOPOULOS
Acting Clerk of the Executive Council

Melbourne City Link Act 1995SURRENDER OF INTERESTS IN
UNRESERVED CROWN LAND

The Governor in Council, on the recommendation of the Minister for Planning and Local Government (being the Minister administering the **Melbourne City Link Act 1995**) under section 26(2) of the **Melbourne City Link Act 1995** declares that the interests (if any) in the stratum of Crown land beneath a depth of 10 metres below the surface area of 3360m² shown diagonally hatched on the plan numbered LEGL./99-45 lodged in the Central Plan Office are surrendered to the Crown.

Dated 28 April 1999.

Responsible Minister:
ROBERT MACLELLAN
Minister for Planning
and Local Government

BILL ZISIMOPOULOS
Acting Clerk of the Executive Council

Melbourne City Link Act 1995SURRENDER OF INTERESTS IN
UNRESERVED CROWN LAND

The Governor in Council, on the recommendation of the Minister for Planning and Local Government (being the Minister administering the **Melbourne City Link Act 1995**) under section 26(2) of the **Melbourne City Link Act 1995** declares that the interests (if any) in the area of 480m² shown diagonally hatched on the plan numbered LEGL./98-45 lodged in the Central Plan Office are surrendered to the Crown.

Dated 28 April 1999.

Responsible Minister:
ROBERT MACLELLAN
Minister for Planning
and Local Government

BILL ZISIMOPOULOS
Acting Clerk of the Executive Council

Crown Land (Reserves) Act 1978

NOTICE OF INTENTION

The Governor in Council under Section 10 of the **Crown Land (Reserves) Act 1978** gives notice of intention to revoke the following temporary reservations:

GUILDFORD — The temporary reservation by Order in Council of 21 October, 1902 of an area of 1.619 hectares of land in Section 16, Parish of Guildford as a site for Supply of Gravel. — (Rs 3502).

RAINBOW — The temporary reservation by Order in Council of 5 August, 1910 of an area of 2.853 hectares of land in Section 9, Township of Rainbow, (formerly Parish of Werrap) as a site for a Public Park, so far only as the portion containing 1.029 hectares shown as Crown Allotment 28, Section 9, Township of Rainbow, Parish of Werrap on Certified Plan No. 119336 lodged in the Central Plan Office. — (Rs 2957).

This Order is effective from the date on which it is published in the Victoria Government Gazette.

Dated 28 April 1999.

Responsible Minister:
MARIE TEHAN
Minister for Conservation
and Land Management

BILL ZISIMOPOULOS
Acting Clerk of the Executive Council

Crown Land (Reserves) Act 1978

NOTICE OF INTENTION

The Governor in Council under Section 10 of the **Crown Land (Reserves) Act 1978** gives notice of intention to revoke the following temporary reservations:

PHILLIP ISLAND — The temporary reservation under Section 5 of the **Crown Land (Reserves) Act 1978** of 7573 square metres of land in the Parish of Phillip Island, transferred to the Crown by transfer No. M823626G registered in the Office of Titles on 6 May, 1987 as a site for the conservation of an area of natural interest or beauty and the propagation or management of wildlife or the preservation of wildlife habitat. — (Rs 37110).

PHILLIP ISLAND — The temporary reservation under Section 5 of the **Crown Land (Reserves) Act 1978** of 19.55 hectares of land being Crown Allotment 15, Section A, Parish of Phillip Island, transferred to the Crown by transfer No. G260540 registered in the Office of Titles on 2 August, 1976 as a site for preservation or management of wildlife or the preservation of wildlife habitat. — (Rs 10421).

This Order is effective from the date on which it is published in the Victoria Government Gazette.

Dated 28 April 1999.

Responsible Minister:
MARIE TEHAN
Minister for Conservation
and Land Management

BILL ZISIMOPOULOS
Acting Clerk of the Executive Council

Crown Land (Reserves) Act 1978

REVOCATION OF TEMPORARY RESERVATIONS

The Governor in Council under Section 10 of the **Crown Land (Reserves) Act 1978** revokes the following temporary reservations to the extent indicated hereunder:

GLENLYON — The temporary reservation by Order in Council of 9 March, 1886 of an area of 1.021 hectares of land in Section 40, Township of Glenlyon, Parish of Glenlyon, (formerly Town of Glenlyon) as a site for Watering purposes, revoked as to part by Order in Council of 7 May, 1900 so far as the balance remaining containing 2466 square metres. — (05/13494).

SMYTHESDALE — The whole of the temporary reservation by Order in Council of 17 December, 1963 of an area of 4047 square metres, more or less, of land in Section 47, Township of Smythesdale, Parish of Smythesdale as a site for Public Recreation. — (Rs 8291).

This Order is effective from the date on which it is published in the Victoria Government Gazette.

Dated 28 April 1999.

Responsible Minister:
MARIE TEHAN
Minister for Conservation
and Land Management

BILL ZISIMOPOULOS
Acting Clerk of the Executive Council

Crown Land (Reserves) Act 1978

REVOCATION OF TEMPORARY RESERVATIONS

The Governor in Council under Section 10 of the **Crown Land (Reserves) Act 1978** revokes the following temporary reservations:

BULLEEN — The temporary reservation by Order in Council of 12 April, 1983 of an area of 1349 square metres of land being Crown Allotment A1, Section 9, Parish of Bulleen as a site for Health Commission purposes. — (Rs 11947).

CLEAR LAKE — The temporary reservation by Order in Council of 13 March, 1928 of an area of 9333 square metres of land in Section 1, township of Clear Lake, (formerly Township of Jangeowra), Parish of Carchap, as a site for a State School. — (Rs 3640).

CLEAR LAKE — The temporary reservation by Order in Council of 18 September, 1973 of an area of 582 square metres of land in Section 1, Township of Clear Lake, Parish of Carchap as a site for State School purposes. — (Rs 3640).

CUT-PAW-PAW — The temporary reservation by Order in Council of 8 July, 1980 of an area of 663 square metres of land being Crown Allotment 12A, Section 5, Parish of Cut-paw-paw as a site for Department of Community Welfare Services purposes. — (Rs 11334).

CUT-PAW-PAW — The temporary reservation by Order in Council of 26 February, 1985 of an area of 2379 square metres of land being Crown Allotment 18A, Portion 18, Parish of Cut-paw-paw as a site for Community Welfare Services purposes. — (Rs 12795).

DANDENONG — The temporary reservation by Order in Council of 5 May, 1987 of an area of 601 square metres of land being Crown Allotment D1, Section 24, Parish of Dandenong as a site for Community Purposes. — (Rs 13430).

DANDENONG — The temporary reservation by Order in Council of 18 November, 1986 of an area of 2250 square metres of land being Crown Allotment 22G, Parish of Dandenong as a site for Community purposes. — (Rs 13218).

DANDENONG — The temporary reservation by Order in Council of 11 February, 1975 of an area of 669 square metres of land being Crown Allotment 71A, Parish of Dandenong as a site for Public Purposes (Social Welfare Department purposes). — (Rs 10015).

DOUTTA GALLA — The temporary reservation by Order in Council of 5 October, 1976 of an area of 534 square metres of land being Crown Allotment 2D, Section 10, Parish of Doutta Galla as a site for Public Purposes (Social Welfare Department purposes). — (Rs 10179).

DOUTTA GALLA — The temporary reservation by Order in Council of 13 January, 1976 of an area of 534 square metres of land being Crown Allotment 2C, Section 10, Parish of Doutta Galla as a site for Public Purposes (Social Welfare Department purposes). — (Rs 10104).

DOUTTA GALLA — The temporary reservation by Order in Council of 1 April 1976 of an area of 1065 square metres of land being Crown Allotment E, Section 6, Parish of Doutta Galla as a site for Public Purposes (Social Welfare Department purposes). — (Rs 10199).

EUMEMMERRING — The temporary reservation by Order in Council of 4 December, 1973 of an area of 948 square metres of land being Crown Allotment 38A, Parish of Eumemmerring as a site for Public Purposes (Social Welfare Department purposes). — (Rs 9814).

FRANKSTON — The temporary reservation by Order in Council of 5 November, 1986 of an area of 805 square metres of land being Crown Allotment 49A, Parish of Frankston as a site for Community Welfare Purposes. — (Rs 13189).

HEIDELBERG — The temporary reservation by Order in Council of 22 December, 1987 of an area of 2006 square metres of land being Crown Allotment 14A, Section 19, Township of Heidelberg, Parish of Keelbundora as a site for Community Services. — (Rs 13630).

KEILOR — The temporary reservation by Order in Council of 11 September, 1979 of an area of 555 square metres of land being Crown Allotment 39A, Township of Keilor, Parish of Doutta Galla as a site for Social Welfare purposes. — (Rs 10703).

MARIBYRNONG — The temporary reservation by Order in Council of 24 February, 1976 of an area of 551 square metres of land being Crown Allotment 7A, Section C, Parish of Maribyrnong as a site for Public Purposes (Social Welfare Department purposes). — (Rs 10171).

MARIBYRNONG — The temporary reservation by Order in Council of 13 January 1976 of an area of 602 square metres of land being Crown Allotment 7B, Section C, Parish of Maribyrnong as a site for Public Purposes (Social Welfare Department purposes). — (Rs 10078).

PRAHRAN — The temporary reservation by Order in Council of 30 October, 1973 of an area of 1171 square metres of land being Crown Allotment 62A, Parish of Prahran as a site for Public Purposes (Social Welfare Department purposes). — (Rs 9800).

SHEPPARTON — The temporary reservation by Order in Council of 14 July, 1998 of an area of 793 square metres of land being Crown Allotment 5D, Parish of Shepparton as a site for Public Purposes (Department of Human Services purposes). — (P364231).

SHEPPARTON — The temporary reservation by Order in Council of 6 September, 1988 of an area of 792 square metres of land being Crown Allotment 78R, Parish of Shepparton as a site for Public Purposes (Community Service Purposes). — (Rs 13787).

SHEPPARTON — The temporary reservation by Order in Council of 24 February, 1981 of an area of 713 square metres of land being Crown Allotment 9C, Parish of Shepparton as a site for Department of Community Welfare Services purposes. — (Rs 11336).

SHEPPARTON — The temporary reservation by Order in Council of 10 March, 1982 of an area of 713 square metres of land being Crown Allotment 78E, Parish of Shepparton as a site for Department of Community Welfare Services purposes. — (Rs 11728).

TARNEIT — The temporary reservation by Order in Council of 20 January, 1976 of an area of 545 square metres of land being Crown Allotment F, Section 6, Parish of Tarneit as a site for Public purposes (Social Welfare Department purposes). — (Rs 10098).

TARNEIT — The temporary reservation by Order in Council of 21 October, 1975 of an area of 577 square metres of land being Crown Allotment E, Section 6, Parish of Tarneit as a site for Public Purposes (Social Welfare Department purposes). — (Rs 10110).

TOONGABBIE SOUTH — The temporary reservation by Order in Council of 2 October, 1882 of an area of 1.576 hectares of land in the Parish of Toongabbie South as a site for Railway purposes. — (2006836).

WILL-WILL-ROOK — The temporary reservation by Order in Council of 10 April, 1979 of an area of 687 square metres of land being Crown Allotment 1A, Parish of Will-will-rook as a site for Social Welfare purposes. — (Rs 10542).

WOOLAMAI — The temporary reservation by Order in Council of 10 August 1914 of an area of 2.023 hectares of land in the Township of Woolamai, (formerly Township of Marrooing), Parish of Woolamai as a site for a State School, revoked as to part by Order in Council of 22

November, 1944, so far as the balance remaining containing 1.953 hectares. — (Rs 3911).

This Order is effective from the date on which it is published in the Victoria Government Gazette.

Dated 28 April 1999.

Responsible Minister:
MARIE TEHAN
Minister for Conservation
and Land Management

BILL ZISIMOPOULOS
Acting Clerk of the Executive Council

Crown Land (Reserves) Act 1978
CROWN LANDS TEMPORARILY
RESERVED

The Governor in Council under Section 4(1) of the **Crown Land (Reserves) Act 1978** temporarily reserves the following Crown lands for the purposes mentioned:-

MUNICIPAL DISTRICT OF THE
EAST GIPPSLAND SHIRE COUNCIL

BETKA — Public purposes (Aerodrome purposes), 240 hectares, being Crown Allotment 8, Parish of Betka as shown on Certified Plan No. 112120 lodged in the Central Plan Office. — (16/2006882).

MUNICIPAL DISTRICT OF THE
MILDURA RURAL CITY COUNCIL

GORYA — Conservation of an area of natural interest, 2.344 hectares being Crown Allotment 13B, Parish of Gorya as indicated by hatching on plan hereunder. (G241[3]) — (2007075).

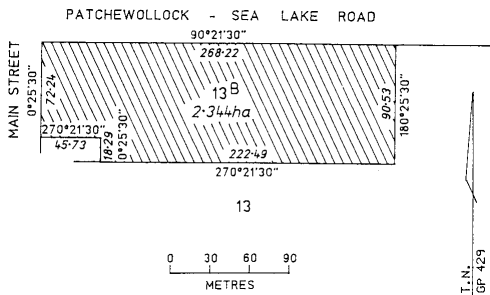

MUNICIPAL DISTRICT OF THE
BASS COAST SHIRE COUNCIL

PHILLIP ISLAND — Conservation of an area of natural interest, being the land in the Parish of Phillip Island indicated by hatching on plan hereunder and known as Crown Allotment 1K1. (P136[5]) — (Rs 337173).

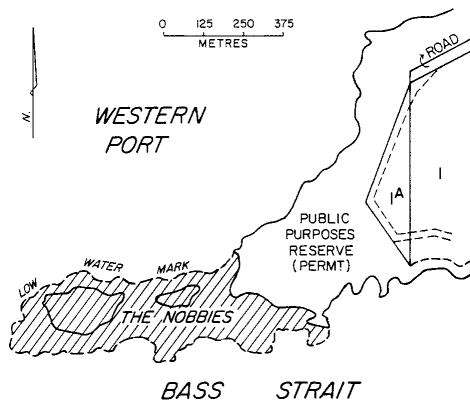

MUNICIPAL DISTRICT OF THE
MORNINGTON PENINSULA SHIRE
COUNCIL

WANNAEUE — Public purposes, 2156 square metres, being Crown Allotment 4, Section B, Parish of Wannaeue as shown on Certified Plan No. 101461 lodged in the Central Plan Office. — (Rs 9950).

This Order is effective from the date on which it is published in the Victoria Government Gazette.

Dated 28 April 1999.

Responsible Minister:
MARIE TEHAN
Minister for Conservation
and Land Management

BILL ZISIMOPOULOS
Acting Clerk of the Executive Council

Crown Land (Reserves) Act 1978
NOTICE OF INTENTION

The Governor in Council under Section 10 of the **Crown Land (Reserves) Act 1978** gives notice of intention to revoke the following temporary reservations to the extent indicated hereunder:

MARONG — The temporary reservation by Order in Council of 23 October, 1956 of an area of 1.153 hectares of land in Section 8, Township of Marong, Parish of Marong as a site for a Municipal Depot, so far only as the portion containing 8633 square metres shown as Crown Allotment 1A, Section 8, Township of Marong, Parish of Marong on Certified Plan No. 118825 lodged in the Central Plan Office. — (Rs 7509).

This Order is effective from the date on which it is published in the Victoria Government Gazette.

Dated 28 April 1999.

Responsible Minister:
MARIE TEHAN
Minister for Conservation
and Land Management

BILL ZISIMOPOULOS
Acting Clerk of the Executive Council

Crown Land (Reserves) Act 1978

NOTICE OF INTENTION

The Governor in Council under Section 10 of the **Crown Land (Reserves) Act 1978** gives notice of intention to revoke the following temporary reservations to the extent indicated hereunder:

ARARAT — The temporary reservation by Order in Council of 22 May, 1905 of an area of 4856 square metres of land in Section 2, Township of Ararat, Parish of Ararat, (formerly municipal district of Ararat) as a site for Drainage purposes, revoked as to part by Order in Council of 2 November, 1955, together with the temporary reservation of the remaining area for the additional purpose of Public Recreation by Order in Council 2 May, 1962 so far as the balance remaining containing 4578 square metres. — (Rs 910).

ARARAT — The temporary reservation by Order in Council of 16 December, 1969 of an area of 8.240 hectares of land in Section 81A, Township of Ararat, Parish of Ararat as a site for State (Technical) School purposes, so far only as the portion containing 2.978 hectares as indicated by hatching on plan hereunder. (A147[7]) — (Rs 9118).

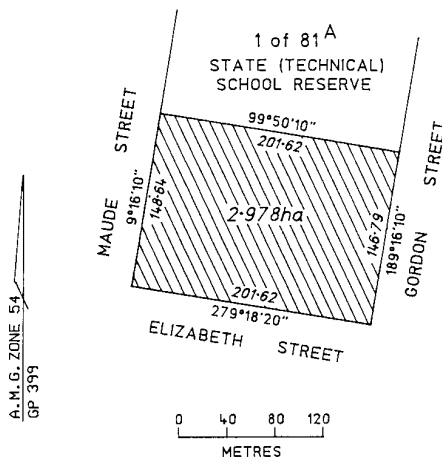

BARMAH — The temporary reservation by Order in Council of 24 February, 1896 of an area of 8094 square metres of land in Section 8, Township of Barmah, Parish of Barmah (formerly Crown Allotments 7, 8, 9 and 10) as a site for a State School, revoked as to part by Order in Council of 18 July, 1995 so far as the balance remaining containing 7262 square metres. — (Rs 0804510).

JAN JUC — The whole of the temporary reservation by Order in Council of 25 March, 1969 of an area of 5.390 hectares of land in the Parish of Jan Juc as a site for Public Recreation. — (Rs 9087).

This Order is effective from the date on which it is published in the Victoria Government Gazette.

Dated 28 April 1999.

Responsible Minister:
MARIE TEHAN
Minister for Conservation
and Land Management

BILL ZISIMOPOULOS
Acting Clerk of the Executive Council

Crown Land (Reserves) Act 1978

REVOCATION OF TEMPORARY RESERVATIONS

The Governor in Council under Section 10 of the **Crown Land (Reserves) Act 1978** revokes the following temporary reservations to the extent indicated hereunder:

EAGLEHAWK — The temporary reservation by Order in Council of 11 February, 1878 of an area of 1.796 hectares, more or less, of land At Eaglehawk, Parish of Sandhurst (formerly municipal district of Eaglehawk) as a site for a Storm-water Channel, so far only as the portion containing 2650 square metres, more or less, as indicated by hatching on plan published in the Victoria Government Gazette on 18 March, 1999 - page 688. — (Rs 6900).

GUTCHA — The whole of the temporary reservation by Order in Council of 11 July, 1921 of an area of 1.012 hectares of land being Crown Allotment 47A, Parish of Gutchu as a site for a State School. — (01/05289).

NEERIM — The whole of the temporary reservation by Order in Council of 18 February, 1969 of an area of 127 square metres, more or

less, of land in the Township of Neerim, Parish of Neerim as a site for State School purposes. — (Rs 2845).

NEERIM — The whole of the temporary reservation by Order in Council of 30 October, 1923 of an area of 683 square metres of land in the Parish of Neerim (formerly Village of Neerim) as a site for a State School. — (Rs 2845).

This Order is effective from the date on which it is published in the Victoria Government Gazette.

Dated 28 April 1999.

Responsible Minister:
MARIE TEHAN
Minister for Conservation
and Land Management

BILL ZISIMOPOULOS
Acting Clerk of the Executive Council

Crown Land (Reserves) Act 1978

REVOCATION OF TEMPORARY RESERVATIONS

The Governor in Council under Section 10 of the **Crown Land (Reserves) Act 1978** revokes the following temporary reservations to the extent indicated hereunder:

ALEXANDRA — The whole of the temporary reservation by Order in Council of 1 December, 1987 of an area of 966 square metres of land being Crown Allotment 2A, Section 13, Township of Alexandra, Parish of Alexandra as a site for Health purposes. — (Rs 13417).

ARARAT — The temporary reservation by Order in Council of 14 July, 1959 of an area of 6070 square metres, more or less, of land in Section 67, Township of Ararat, Parish of Ararat as a site for the purposes of the Children's Welfare Department, revoked as to part by Orders in Council of 14 June, 1972 and 11 September, 1984, so far as the balance remaining containing 2035 square metres, more or less. — (Rs 7839).

BENDIGO — The whole of the temporary reservation by Order in Council of 8 June, 1982 of an area of 2450 square metres of land being Crown Allotment 15, Section 8B, At Bendigo, Parish of Sandhurst as a site for Health Commission purposes. — (Rs 10494).

BRUNSWICK — The whole of the temporary

reservation by Order in Council of 25 February, 1969 of an area of 506 square metres of land in Section 4, City of Brunswick, Parish of Jika Jika as a site for Public purposes (Departmental residence). — (Rs 9125).

BULLEEN — The whole of the temporary reservation by Order in Council of 25 November, 1986 of an area of 557 square metres of land being Crown Allotment 11, Section A, Parish of Bulleen as a site for Community Purposes. — (Rs 13331).

BULLEEN — The whole of the temporary reservation by Order in Council of 31 May, 1983 of an area of 758 square metres of land being Crown Allotment 8, Section A, Parish of Bulleen as a site for Health Commission purposes — (Rs 12252).

BUNBARTHA — The temporary reservation by Order in Council of 18 July, 1881 of an area of 8094 square metres of land in Section E, Township of Bunbartha, Parish of Tallygaroopna (formerly village of Bunbartha) as a site for Public purposes (State School), revoked as to part by Order in Council of 3 October, 1995, so far as the balance remaining. — (Rs 8193).

BUNBARTHA — The temporary reservation by Order in Council of 17 June, 1964 of an area of 7082 square metres of land in Section E, Township of Bunbartha, Parish of Tallygaroopna as a site for State School purposes, revoked as to part by Order in Council of 3 October, 1995, as far as the balance remaining. — (Rs 8193).

CUT-PAW-PAW — The whole of the temporary reservation by Order in Council of 21 January, 1986 of an area of 605 square metres of land being Crown Allotment A1, Section 5, Parish of Cut-paw-paw as a site for Health purposes. — (Rs 13027).

GEELONG — The temporary reservation by Order in Council of 30 July, 1968 of an area of 2808 square metres of land in Section 86, City of Geelong, Parish of Corio as a site for Public Purposes (Public Buildings), revoked as to part by Order in Council of 15 September, 1987, so far as the balance remaining containing 1934 square metres. — (Rs 9018).

KEELBUNDORA — The whole of the temporary reservation by Order in Council of 21 January, 1986 of an area of 547 square metres of

land being Crown Allotment 19D, Parish of Keelbundora as a site for Health purposes. — (Rs 13019).

MOORABOOL EAST — The whole of the temporary reservation by Order in Council of 28 January, 1879 of an area of 1.214 hectares of land in Section C, Parish of Moorabool East (formerly at Blakeville) as a site for Public purposes (State School). — (Rs 3668).

MOOROOLBARK — The whole of the temporary reservation by Order in Council of 26 November, 1985 of an area of 792 square metres of land being Crown Allotment 44C, Parish of Mooroolbark as a site for Health Commission purposes. — (Rs 13028).

NUNAWADING — The whole of the temporary reservation by Order in Council of 21 January, 1986 of an area of 1033 square metres of land being Crown Allotment 6, Section A, Parish of Nunawading as a site for Health purposes. — (Rs 12565).

NUNAWADING — The whole of the temporary reservation by Order in Council of 18 November, 1986 of an area of 601 square metres of land being Crown Allotment 2A, Parish of Nunawading as a site for Community Services. — (Rs 13330).

SCORESBY — The whole of the temporary reservation by Order in Council of 11 June, 1986 of an area of 971 square metres of land being Crown Allotment 29B, Parish of Scoresby as a site for health purposes. — (Rs 13013).

SHEPPARTON — The whole of the temporary reservation by Order in Council of 1 July, 1986 of an area of 836 square metres of land being Crown Allotment 5C, Parish of Shepparton as a site for health purposes. — (Rs 12874).

SWAN HILL — The whole of the temporary reservation by Order in Council of 19 July, 1977 of an area of 728 square metres of land being Crown Allotment 7, Section 44, Township of Swan Hill, Parish of Castle Donnington as a site for Public Purposes (Social Welfare Department purposes). — (Rs 10354).

WANGARATTA SOUTH — The whole of the temporary reservation by Order in Council of 30 October, 1979 of an area of 605 square metres of land being Crown Allotment 1A, Section 7, Parish of Wangaratta South as a site for Social Welfare purposes. — (Rs 10775).

WANGARATTA SOUTH — The whole of the temporary reservation by Order in Council of 7 April, 1983 of an area of 1011 square metres of land being Crown Allotment 1A, Section 4, Parish of Wangaratta South as a site for Health Commission purposes. — (Rs 12247).

WANGARATTA SOUTH — The whole of the temporary reservation by Order in Council of 11 August, 1981 of an area of 560 square metres of land being Crown Allotment 1B, Section 7, Parish of Wangaratta South as a site for Departmental residence. — (Rs 11456).

WANGARATTA SOUTH — The whole of the temporary reservation by Order in Council of 20 August, 1985 of an area of 843 square metres of land being Crown Allotment 1C, Section 7, Parish of Wangaratta South as a site for Health Commission purposes. — (Rs 12939).

WODONGA — The whole of the temporary reservation by Order in Council of 20 January, 1981 of an area of 808 square metres of land being Crown Allotment 1A, Section H, Parish of Wodonga as a site for Community Welfare Service purposes. — (Rs 11092).

This Order is effective from the date on which it is published in the Victoria Government Gazette.

Dated 28 April 1999.

Responsible Minister:
MARIE TEHAN
Minister for Conservation
and Land Management

BILL ZISIMOPOULOS
Acting Clerk of the Executive Council

Crown Land (Reserves) Act 1978
CROWN LANDS TEMPORARILY
RESERVED

The Governor in Council under Section 4(1) of the **Crown Land (Reserves) Act 1978** temporarily reserves the following Crown lands for the purposes mentioned:-

MUNICIPAL DISTRICT OF THE
ARARAT RURAL CITY COUNCIL

ARARAT — Public Recreation, 4500 square metres, more or less, being Crown Allotment 50B, Section K, Township of Ararat, Parish of Ararat as indicated by hatching on plan hereunder. (A148[10]) — (Rs 21075).

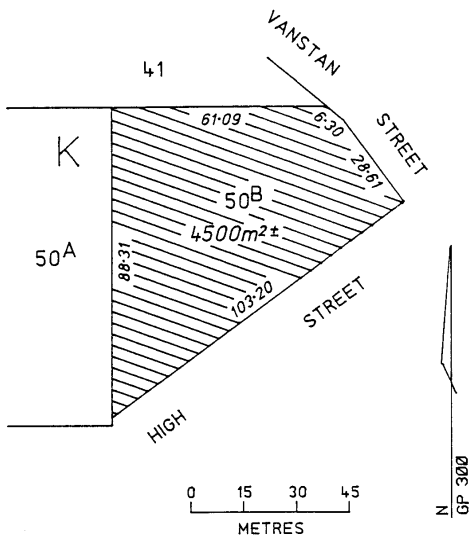

This Order is effective from the date on which it is published in the Victoria Government Gazette.

Dated 28 April 1999.

Responsible Minister:
 MARIE TEHAN
 Minister for Conservation
 and Land Management

BILL ZISIMOPOULOS
 Acting Clerk of the Executive Council

Land Act 1958

UNUSED ROADS CLOSED

The Governor in Council under Section 349 of the **Land Act 1958** and with the consent in writing of the municipalities concerned closes the following unused roads:

MUNICIPAL DISTRICT OF THE EAST GIPPSLAND SHIRE COUNCIL
BAIRNSDALE — The roads in the:-

1. Township of Bairnsdale, Parish of Bairnsdale shown as Crown Allotment 2G, Section 1 on Certified Plan No. 117904 lodged in the Central Plan Office; and
2. Township of Bairnsdale, Parish of Bairnsdale as indicated by hatching on plan hereunder. (B66[11]) — (L9-5050).

MUNICIPAL DISTRICT OF THE EAST GIPPSLAND SHIRE COUNCIL
BAIRNSDALE — State school purposes, 3136 square metres, being Crown Allotment 2G, Section 1, Township of Bairnsdale, Parish of Bairnsdale as shown on Certified Plan No. 117904 and Crown Allotment 2H, Section 1, Township of Bairnsdale, Parish of Bairnsdale as shown on Certified Plan No. 117905, both lodged in the Central Plan Office. — (Rs 2300).

MUNICIPAL DISTRICT OF THE MILDURA RURAL CITY COUNCIL
MILDURA — State school purposes, 1.643 hectares being Crown Allotment 456C, Section B, Parish of Mildura as indicated by hatching on plan hereunder. (M556[20]) — (2007068).

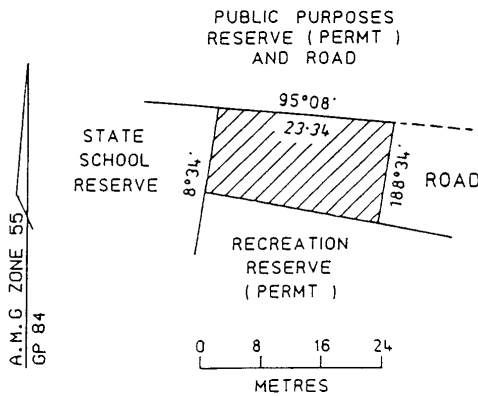
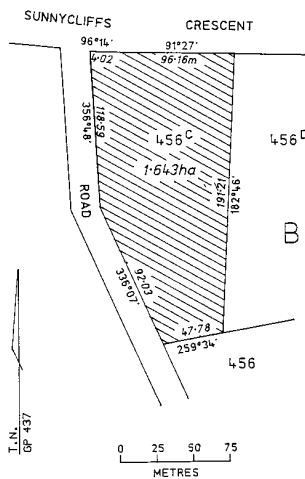

MUNICIPAL DISTRICT OF THE BASS COAST SHIRE COUNCIL

WONTHAGGI — The road in the Township of Wonthaggi, Parish of Wonthaggi as indicated by hatching on plan hereunder. (W345[17]) — (12/P240747).

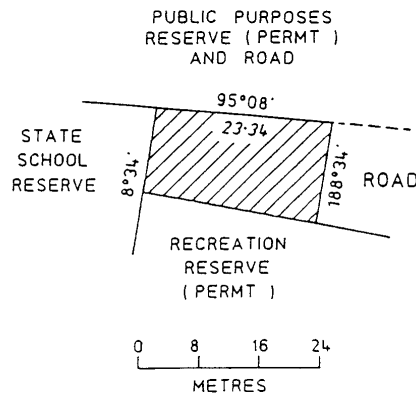

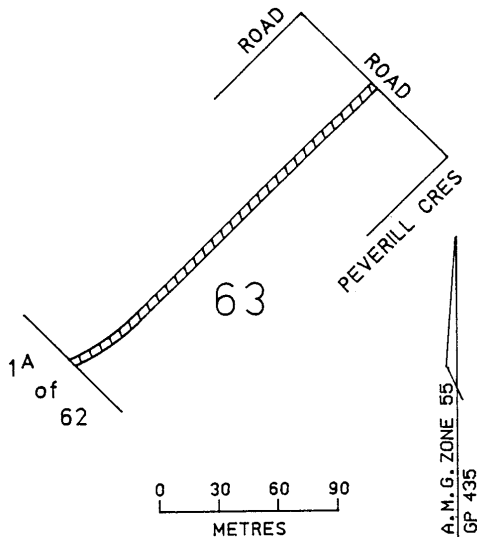

This Order is effective from the date on which it is published in the Victoria Government Gazette.

Dated 28 April 1999.

Responsible Minister:
MARIE TEHAN
Minister for Conservation
and Land Management

BILL ZISIMOPOULOS
Acting Clerk of the Executive Council

Crown Land (Reserves) Act 1978

**INCORPORATION OF COMMITTEE OF
MANAGEMENT OF THE CHINAMAN'S
LAGOON TEESDALE PUBLIC PURPOSES
RESERVE**

The Governor in Council under Section 14A(1) of the **Crown Land (Reserves) Act 1978**, being satisfied that it is in the public interest to declare to be a corporation the Committee of Management appointed under Section 14(2) of the Act of the land described in the schedule hereunder:-

- (a) declares the Committee of Management shall be a corporation;
- (b) assigns the name "CHINAMAN'S LAGOON TEESDALE COMMITTEE OF MANAGEMENT INCORPORATED" to the corporation; and

under Section 14B(3) of the Act, appoints Alan HELYAR to be Chairperson of the corporation.

SCHEDULE

Crown Allotment 51A, Township of Teesdale, Parish of Carrah temporarily reserved as a site for Public purposes by Order in Council of March, 1999. — P141462.

This Order is effective from the date on which it is published in the Victoria Government Gazette.

Dated 28 April 1999.

Responsible Minister:
MARIE TEHAN
Minister for Conservation
and Land Management

BILL ZISIMOPOULOS
Acting Clerk of the Executive Council

VICTORIA

State Aid to Religion Abolition Act 1871

ACT NO. 391/1871 — SECOND SCHEDULE

A statement of trusts having been submitted by the head or authorised representative of the Roman Catholic Church for the Diocese of Ballarat under the provisions of the "Act to provide for the abolition of State Aid to Religion" for allowance by the Governor in Council, the same was allowed by him on the Twenty-eighth day of April 1999, and the following is the form in which such statement of trusts has been allowed.

STATEMENT OF TRUSTS

DESCRIPTION OF LAND -

Site for Roman Catholic Place of Public Worship permanently reserved by Order in Council 4 July, 1870. 4045 square metres, Township of Waubra, Parish of Ercildoun being Allotment 1, Section 159;

Commencing at the south-eastern angle of Allotment 2, Section 159, bounded thence by a road bearing 180° 00' 82.29 metres, thence by the Sunraysia Highway bearing 311° 17' 127.74 metres, and thence by Allotments 7 and 2 bearing 90° 00' 95.96 metres to the point of commencement.

NAME OF TRUSTEES

The Roman Catholic Trusts Corporation for the Diocese of Ballarat.

POWERS OF DISPOSITION

Such powers of disposition including powers of sale, lease or mortgage as are contained in the

Roman Catholic Trusts Act 1907.

PURPOSES TOWARDS WHICH PROCEEDS
OF DISPOSITION ARE TO BE APPLIED -

To such Roman Catholic Church purposes as
shall be approved by the Trustee.

This Order is effective from the date on
which it is published in the Victoria Government
Gazette.

Dated 28 April 1999.

Responsible Minister:

MARIE TEHAN

Minister for Conservation
and Land Management

BILL ZISIMOPOULOS

Acting Clerk of the Executive Council

**SUBORDINATE LEGISLATION ACT 1994
NOTICE OF MAKING OF STATUTORY
RULES**

Notice is hereby given under Section 17 (2) of the **Subordinate Legislation Act 1994** of the making of the following Statutory Rules:

- | | | | | | |
|----------------------------|--|-------------------------|---|------------------------|---------------|
| 44. <i>Statutory Rule:</i> | Health
(Immunisation)
Regulations 1999 | <i>Authorising Act:</i> | Health Act 1958 | <i>Date of making:</i> | 28 April 1999 |
| 45. <i>Statutory Rule:</i> | Trans-Tasman Mutual
Recognition (Victoria)
(Temporary
Exemptions)
Regulations 1999 | <i>Authorising Act:</i> | Trans-Tasman Mutual
Recognition (Victoria)
Act 1998 | <i>Date of making:</i> | 28 April 1999 |
| 46. <i>Statutory Rule:</i> | Electricity Safety
(Electrical Appeals
Board) Regulations
1999 | <i>Authorising Act:</i> | Electricity Safety Act
1998 | <i>Date of making:</i> | 28 April 1999 |
| 47. <i>Statutory Rule:</i> | Electricity Safety
(Equipment)
Regulations 1999 | <i>Authorising Act:</i> | Electricity Safety Act
1998 | <i>Date of making:</i> | 28 April 1999 |
| 48. <i>Statutory Rule:</i> | Electricity Safety
(Equipment
Efficiency)
Regulations 1999 | <i>Authorising Act:</i> | Electricity Safety Act
1998 | <i>Date of making:</i> | 28 April 1999 |
| 49. <i>Statutory Rule:</i> | Electricity Safety
(Installations)
Regulations 1999 | <i>Authorising Act:</i> | Electricity Safety Act
1998 | <i>Date of making:</i> | 28 April 1999 |
| 50. <i>Statutory Rule:</i> | Electricity Safety
(Stray Current
Corrosion)
Regulations 1999 | <i>Authorising Act:</i> | Electricity Safety Act
1998 | <i>Date of making:</i> | 28 April 1999 |

**SUBORDINATE LEGISLATION ACT 1994
NOTICE THAT STATUTORY RULES ARE
OBTAINABLE**

Notice is hereby given under Section 17 (3) of the **Subordinate Legislation Act 1994** that the following Statutory Rules were first obtainable from Information Victoria, 356 Collins Street, Melbourne on the date specified:

41. *Statutory Rule:* House Contracts Guarantee Regulations 1999
Authorising Act: House Contracts Guarantee Act 1987
Date first obtainable: 26 April 1999
Code A
42. *Statutory Rule:* Tobacco (Victorian Health Promotion Foundation) (Amendment) Regulations 1999
Authorising Act: Tobacco Act 1987
Date first obtainable: 27 April 1999
Code A
43. *Statutory Rule:* Physiotherapists Registration Regulations 1999
Authorising Act: Physiotherapists Registration Act 1998
Date first obtainable: 26 April 1999
Code A

Retail price will vary according to the number of pages in each special or periodical gazette. The table below sets out the prices that apply

<i>Price Code</i>	<i>No. of Pages (Including cover and blank pages)</i>	<i>Price</i>
A	1-16	\$2.90
B	17-32	\$4.30
C	33-48	\$5.90
D	49-96	\$9.15
E	97-144	\$11.85
F	145-192	\$14.00
G	193-240	\$16.15
H	241-288	\$17.20
I	289-352	\$19.35
J	353-416	\$22.60
K	417-480	\$25.80
L	481-544	\$30.10
M	545-608	\$34.40
N	609-672	\$38.70
O	673-736	\$43.00
P	737-800	\$47.30

ADVERTISERS PLEASE NOTE

As from 29 April 1999

The last Special Gazette was No. 57 dated 28 April 1999

The last Periodical Gazette was No. 1 dated 2 June 1998

CONTENTS

	Page
Estates of Deceased Persons	957
Government and Outer Budget Sector	
Agencies Notices	969
Orders in Council—	995
Acts — Cemeteries; Electricity Safety; Gas Industry; Chattel Securities; Melbourne City Link; Crown Land (Reserves); Land; State Aid to Religion Abolition	
Private Advertisements	957
Proclamations	967

The Victoria Government Gazette is published by The Craftsman Press Pty. Ltd. with the authority of the Government Printer for the State of Victoria
© State of Victoria 1999

ISSN 0819-5471

This publication is copyright. No parts may be reproduced by any process except in accordance with the provisions of the Copyright Act.

Products and services advertised in this publication are not endorsed by The Craftsman Press Pty. Ltd. or the State of Victoria and neither of them accepts any responsibility for the content or the quality of reproduction. The Craftsman Press Pty. Ltd. reserves the right to reject any advertising material it considers unsuitable for government publication.

Address all inquiries to the Government Printer for the State of Victoria
1 Macarthur Street
Melbourne 3002 Victoria Australia

Government and Outer Budget Sector Agencies please note:
STYLE REQUIREMENTS.

To ensure that material received can be reproduced, and that errors are minimised, the following guidelines are to be observed when submitting material by fax.

Fax resolution:

Material sent by fax should be transmitted using Fine Resolution (200 dots per inch by 200 dpi).

Font size:

Use 12 point (10 pitch) or larger.

Font Style:

Clear plain font styles, such as Helvetica, should be used.

Graphics:

Line drawings should be transmitted as large as possible to ensure clarity. Drawings up to A4 size sent by fax using Fine Resolution provide a good quality for reproduction.

Avoid:

Italics, underlining and full justification.

Ensure document is square when sending as documents that are sent skewed are difficult to read and process.

RETAIL SALES

Information Victoria Bookshop
356 Collins Street Melbourne 3000.
Telephone enquiries 1300 366 356

City Graphics
2nd Floor, 4 Bank Place
Melbourne 3000
Telephone enquiries (03) 9600 0977

Recommended Retail Price \$1.70

ISSN 0819-5471

