



Victoria Government Gazette

No. G 33 Thursday 19 August 1999

GENERAL

GENERAL AND PERIODICAL GAZETTE

Copy to: Gazette Officer
The Craftsman Press Pty. Ltd.
125 Highbury Road,
Burwood Vic 3125
Telephone: (03) 9926 1233
Facsimile: (03) 9926 1292
DX: 32510 Burwood
Email: gazette@craftpress.com.au

Advertising Rates and Payment

Private Notices

Payment must be received in advance with advertisement details.

30 cents per word - Full page \$180.00.

Additional costs must be included in prepayment if a copy of the gazette is required. Copy Prices - Page

\$1.50 - Gazette \$3.20 Certified copy of Gazette \$3.50. (all prices include Postage). **Cheques should be made payable to The Craftsman Press Pty. Ltd.**

Government and Outer Budget Sector Agencies Notices

Not required to pre-pay.

Advertisements may be faxed or sent via email with a cover sheet, marked to the attention of the Gazette Officer.

Floppy Disks (Mac & PC) can also be accepted.

Costs can be calculated on the following basis:

Per Line	Typeset
Single column	\$1.55
Double column	\$3.10
Full Page	\$64.80

The Craftsman Press is pleased to offer a series of discounts from the typesetting costs.

1. Copy supplied on disk.
2. Copy supplied via email.
3. Artwork for forms and other material which require exact reproduction.

1. Copy supplied on disk.

Where a disk is supplied and there is minimum alteration required, **30% off.**

Where a disk is supplied requiring extraneous matter stripped out and styles applied, **20% off.**

2. Copy supplied via email.

Where a notice is sent via email and there is minimum alteration required, **25% off.**

Where email is supplied requiring extraneous matter stripped out and styles applied, **15% off.**

3. Artwork for forms and other material which requires exact reproduction.

Scanning and sizing of artwork for forms, to be reproduced in page format, **35% off.**

Copy Deadline for General Gazette

9.30 a.m. Monday - (Private Notices)

9.30 a.m. Tuesday - (Government and Outer Budget Sector Agencies Notices)

Advertisers should note:

- Late copy received at The Craftsman Press Pty. Ltd. after deadlines will be placed in the following issue of VGG, irrespective of any date/s mentioned in the copy (unless otherwise advised).
- Proofs will be supplied only when requested or at the direction of the Gazette Officer.
- No additions or amendments to material for publications will be accepted by telephone.
- Orders in Council may be lodged prior to receiving assent with the Governor's or Clerk's signature. They will only be published once approved and signed.
- Government and Outer Budget Sector Agencies please note: *See style requirements on back page.*

SPECIAL GAZETTES

Copy to: Gazette Officer
The Craftsman Press Pty. Ltd.
125 Highbury Road,
Burwood Vic 3125
Telephone: (03) 9926 1233
Facsimile: (03) 9926 1292
Email: gazette@craftpress.com.au

Advertising Rates and Payment

Private Notices

Full Page \$360.00

Payment must be received in advance with notice details.

Government and Outer Budget Sector Agencies Notices

	Typeset
Full Page	\$87.50

Note:

The after hours number for Special Gazettes is:
Telephone: 0419 327 321

SUBSCRIPTIONS AND RETAIL SALES

Copies of the Victoria Government Gazette can be purchased from The Craftsman Press Pty. Ltd. by subscription.

The Victoria Government Gazette

General and Special - \$170.00 each year

General, Special and Periodical - \$227.00 each year

Periodical - \$113.00 each year

Subscriptions are payable in advance and accepted for a period of one year. All subscriptions are on a firm basis and refunds will not be given.

All payments should be made payable to The Craftsman Press Pty. Ltd.

Subscription enquiries:

The Craftsman Press Pty. Ltd.
125 Highbury Road, Burwood Vic 3125
Telephone: (03) 9926 1233

INDEX TO PRIVATE ADVERTISERS

A

A.B. Natoli Pty	1895
Aitken Walker & Strachan	1895
AXA Trustees Ltd	1895

B

Bruce M. Cook & Associates	1895
----------------------------------	------

C

Craig Popplestone	1895
-------------------------	------

D

Dunhill Madden Butler	1895
-----------------------------	------

E

Eales & Mackenzie	1896
Ellinghaus Weill	1896
Equity Trustees Limited	1896

F

Featherby's	1896
-------------------	------

G

Gadens	1896
Garden & Green	1896
Gilbert Bell & Co.	1897
Gray Friend & Long	1897
Gray & Gray	1897
Gullaci & Gullaci	1897

M

Mills Oakley	1897
Moores	1897
Mosley & Palmer	1897

R

Rigby Cooke	1898
Roberts Partners	1898

W

Wills & Probate Victoria	1898
Wisewoulds	1898

PRIVATE ADVERTISEMENTS

Parterships Act 1958

Federation Cyber-Café ("the Partnership")

Take Notice that on 31 July 1999 the abovenamed Partnership which operated from the premises situate at Unit 20/217 Mickleham Road, Tullamarine was dissolved in accordance with the Notice of Termination served on the said date pursuant to the requirements of the Partnership Deed and the Partnerships Act 1958.

Dated this 3rd day of August 1999.

CRAIG POPPLESTONE, partner.

C/- Fetter Gdanski,

Level 11, 555 Lonsdale Street, Melb., Vic. 3000.

MARIA GRAZIA DE LOSA, late of 58A Gladstone Street, Kew, Victoria, deceased. Creditors, next-of-kin and others having claims in respect of the estate of the abovenamed deceased, who died on 22 May 1999, are required by Lina Notari of 27 Alison Avenue, Bulleen, Victoria, home duties and Nancy Iardi of 166 Nangathan Way, North Croydon, Victoria, bookkeeper and John de Losa of 82 Chirnside Drive, Chirnside Park, Victoria, importer, the executors of the deceased's will, to send particulars of their claim to the said executors care of the undermentioned solicitors by 15 October 1999 after which date they will convey or distribute the assets having regard only to the claims of which they then have notice.

A. B. NATOLI PTY, solicitors,
24 Cotham Road, Kew 3101.

RUBY VERONICA WOOD late of St John's Village Hostel, Williams Road, Wangaratta widow deceased. Creditors next of kin and others having claims in respect of the estate of the deceased who died on the 3 February 1999 are required by the personal representatives Walter William Wood of RMB 1070 Baddaginnie, Geoffrey Ronald Wood of 10 Greenbrook Drive, Epping and Leonard Keith Wood of Chateau Road, Dookie to send particulars to them care of the undermentioned solicitors by the 27 October 1999 after which date the personal representatives may convey or distribute the assets having regard only to the claims of which they then have notice.

AITKEN WALKER & STRACHAN, solicitors
114 William Street, Melbourne 3000.

HAZEL ALMA WARD, late of 14 Gowar Avenue, Camberwell, widow. Creditors, next-of-kin and others having claims in respect of the estate of the deceased, who died on 13 June 1999, are required by AXA Trustees Ltd, formerly National Mutual Trustees Limited, of 65 Southbank Boulevard, Southbank, Victoria 3006, the applicant for a grant of probate, to send particulars to it by 20 October 1999 after which date the applicant for a grant of probate may convey or distribute the assets having regard only to the claims of which it then has notice.

RICHARD ERNEST MURPHY, late of 5B Caserta Drive, Berwick, retired. Creditors, next-of-kin and others having claims in respect of the estate of the deceased, who died on 14 May 1999, are required by AXA Trustees Ltd, (formerly National Mutual Trustees Limited), and Celia Jane Kenny care of 65 Southbank Boulevard, Southbank, Victoria 3006, the applicants for a grant of probate, to send particulars to it by 20 October 1999 after which date the applicants for a grant of probate may convey or distribute the assets having regard only to the claims of which they then have notice.

Creditors, next-of-kin or others having claims in respect of the estate of ROBYN ANNE DAWE of 73 Sandringham Road, Sandringham, in the State of Victoria, company director, who died on 1 May 1999, are to send particulars of their claims to the personal representative/s care of the undermentioned solicitors by 20 October 1999 after which date the personal representative/s will distribute the assets having regard only to the claims of which they then have notice.

BRUCE M. COOK & ASSOCIATES,
barristers & solicitors,
Level 4, St James Building,
121 William Street, Melbourne, Vic. 3000.

Creditors, next-of-kin or others having claims in respect of the estate of PAULINE RUTH BRADLEY, deceased, who died on 20 April 1999, are to send particulars of their claims to the executors, Christina Mary Lord, David Martin Bradley and John Paul Bradley,

care of the 575 Bourke Street, Melbourne, Victoria, by 28 October 1999 after which date the executors will distribute the assets having regard only to the claims of which the executors then have notice.

DUNHILL MADDEN BUTLER, solicitors,
575 Bourke Street, Melbourne.

RUBY ALICE SEBIRE, late of Amaro Nursing Home, Weir Street, Euroa, Home Duties, deceased. Creditors, next-of-kin, and others having claims in respect of the estate of the deceased, who died on the 4 April, 1999 are required by the trustee, Geoffrey Maxwell Sebire of RMB 3078, Violet Town, Victoria, Orchardist, to send particulars to the trustee by the 14 October 1999, after which date the trustee may convey or distribute the assets, having regard only to the claims of which the trustee then has notice.

EALLES & MACKENZIE, solicitors,
114-116 Main Street, Lilydale.

MARIA GETTO late of 14/18 Lernes Street, Forest Hill widow deceased. Creditors next of kin and others having claims in respect of the estate of the deceased who died on 14 May 1999 are required by the personal representatives Vlado Getto of 9 Chestnut Avenue, Ferntree Gully. Slava Bito of 52 Woodcrest Road Vermont and Steven Leslie Weill of 79-81 Franklin Street Melbourne to send particulars to them care of the undermentioned solicitors by 27 October 1999 after which date the personal representatives may convey or distribute the assets having regard only to the claims of which they then have notice.

ELLINGHAUS WEILL, solicitors
79-81 Franklin Street, Melbourne 3000.

Creditors, next-of-kin and others having claims in respect of the estate of CECILY JOYCE MONTGOMERY, late of 50 Intervale Drive, Mallacoota, married woman, deceased, who died on 18 April 1999, are to send particulars of their claims to Equity Trustees Limited, A.C.N. 004 031 298 of 472 Bourke Street, Melbourne by 20 October 1999 after which date it will distribute the assets having regard only to the claims of which it then has notice.

Creditors, next of kin or others having claims in respect of the estate of the late THOMAS VIVIAN BARBER, late of 7 Rose Street, Rosebud in the State of Victoria, deceased, who died on 8 March, 1999 are to send particulars of their claims to the executor care of the undermentioned solicitors by 11 October, 1999 after which date the executor will distribute the assets having regard only to the claims of which he then has notice.

FEATHERBY'S, solicitors,
1043a Point Nepean Road, Rosebud 3939.

Creditors, next-of-kin or others having claims in respect of the estate of RODNEY JOHN FINLAYSON, late of Church Road, Hazelwood North, Victoria, Totaliser Agency Board Agent, deceased, who died on 13 April 1999, are to send particulars of their claims to the executor, care of the undermentioned solicitors by 21 October 1999 after which date the executor will distribute the assets having regard only to the claims of which the executor then has notice.

GADENS, lawyers,
121 William Street, Melbourne.

ALICE EMMA KENNEDY late of 41 Boys Street, Swan Hill, Victoria, Home Duties, deceased. Creditors, next-of-kin, and others having claims in respect of the estate of the deceased, who died on the 10 October 1998, are required by the trustee, Lesley Joy Lambie, to send particulars to her care of the undermentioned Solicitors by the 20 October 1999, after which date the trustee may convey or distribute the assets, having regard only to the claims of which she then has notice.

GARDEN & GREEN, lawyers,
4 McCallum Street, Swan Hill.

MARJORY ALVA HOLMES, late of 13 Birdwood Avenue, Nyah West, Victoria, home duties, deceased. Creditors, next-of-kin and others having claims in respect of the estate of the deceased, who died on 9 February 1999, are required by the trustees, Faye Beverly Atkinson and Janet Margaret Borrman, to send particulars to them care of the undermentioned solicitors by 13 October 1999 after which date the trustees may convey or distribute the assets having regard only to the claims of which they then have notice.

GARDEN & GREEN, lawyers,
4 McCallum Street, Swan Hill.

Creditors, next-of-kin and other persons having claims in respect of the estate of RAYMOND GLEESON KIRWAN, late of 59 Hope Street, Spotswood, Victoria, postal worker, who died on 24 January 1999, are required by the executor of the estate, Anthony Michael Weare of 26 Marriage Road, Brighton, painting contractor, to send particulars of their claims to him care of the undersigned by 20 October 1999 after which date he may convey or distribute the estate having regard only to the claims of which he then has notice.

GILBERT BELL & CO., lawyers
Level 1, 455 Bourke Street, Melbourne.

ROGER JAMES KENT SMITH, late, of Main Road, Hill End, dairy farmer, deceased. Creditors, next-of-kin and others having claims in respect of the estate of the deceased, who died on 15 May 1999, are required by the trustee, Elaine Marion Smith, to send particulars of their claims to her care of the undersigned solicitors by 19 October 1999 after which date the trustee may convey or distribute the assets having regard only to the claims of which she then has notice.

GRAY FRIEND & LONG, solicitors,
70 Queen Street, Warragul 3820.

Creditors, next-of-kin and others having claims in respect of the estate of JACK HIGGINS FIELD, late of 125 Westgarth Street, Northcote, Victoria, retired, who died on 1 May 1999, are to send particulars of their claims to the executors Joyce Plowman and Amanda Joy Plowman, both of 12 Burgess Street, West Preston, care of the undermentioned solicitors by 14 October 1999 after which date the executors will distribute the assets having regard only to the claims of which they then have notice.

GRAY & GRAY, solicitors,
188 High Street, Northcote.

GIOVINA DI FILIPPO, late of 53 Victoria Drive, Thomastown, in the State of Victoria, pensioner, deceased. Creditors, next-of-kin and others having claims in respect of the estate of the abvenamed deceased, who died on 10 June 1999, are required by Maria Gullaci, the executrix of the said estate, to send particulars by 19 October 1999 to her solicitors, Gullaci &

Gullaci of 158 Bell Street, Coburg, after which date the executrix may convey or distribute the assets having regard only to the claims of which she then has notice.

Dated 10 August, 1999.

GULLACI & GULLACI, solicitors,
158 Bell Street, Coburg, Victoria 3058.

Creditors, next-of-kin and others having claims in respect of the estate of CORA DAISY O'SULLIVAN, late of Cadella Park, Woodend, Victoria, widow, deceased, who died on 25 June 1999, are required by the executor, ANZ Executors & Trustee Company Limited of 530 Collins Street, Melbourne, Victoria, to send particulars to it by 20 October 1999 after which date it may convey or distribute the estate having regard only to the claims of which it then has notice.

MILLS OAKLEY, lawyers,
131 Queen Street, Melbourne.

Creditors, next-of-kin and others having claims in respect of the estate of THOMAS VANDENAU, late of Unit 6, 51 Union Street, Windsor, Victoria, storekeeper, deceased, who died on 4 May 1999, are to send particulars of their claim to the executor, ANZ Executors & Trustee Company Limited of 530 Collins Street, Melbourne, Victoria, to send particulars to it by 19 October 1999 after which date it may convey or distribute the estate having regard only to the claims of which it then has notice.

MILLS OAKLEY, lawyers,
131 Queen Street, Melbourne.

Creditors, next-of-kin and others having claims in respect of the estate of NEIL EDWARD CLAYTON, deceased, late of Mattsson Street, Gipsy Point, Victoria, who died on 30 March 1999 are to send particulars of their claims to the Executor, Equity Trustees Limited, care of the undermentioned Solicitors by the 21st day of October 1999 after which date the executor will distribute the assets having regard only to the claims of which the executor then has notice.

MOORES, solicitors,
9 Prospect Street, Box Hill 3128.

JACK DONCHI, late of Unit 16, 90 Boundary Road, Orbost, Victoria, pensioner.

Creditors, next-of-kin and others having claims in respect of the estate of the deceased, who died on or about 27 January 1999, are required by the administrator, Jean Muir of Unit 39, 325 Station Street, Box Hill South, Victoria, home duties, to send particulars to her solicitors within sixty days from the date of publication of this notice after which date the administrator may convey or distribute the assets having regard only to the claims of which they then have notice.

MOSLEY & PALMER, solicitors,
P.O. Box 243, Orbost 3888.

Creditors, next of kin and others having claims in respect of the Estate of MAXIME MARGARET FRANKLYN late of Unit 1, 251 Maribyrnong Road, Ascot Vale in the State of Victoria Home Duties deceased who died on the 18 November 1998 are required by the Executor and Trustee Keith Patrick Franklyn of 14 Fitzroy Street, McKinnon, Victoria, Building Surveyor to send particulars to him by the 24 June 1999, after which date the Executor and Trustee may convey or distribute the assets having regard only to the claims of which he has notice.

RIGBY COOKE, solicitors,
Level 36, 101 Collins Street, Melbourne 3000.

Marjorie Annie Meggs, late of 1 Royston Street, East Burwood, but formerly of Unit 13, 77 Tanti Avenue, Mornington, Home Duties deceased. Creditors, next-of-kin or others having claims in respect of the estate of the deceased, who died on 31 October 1998 are required by the trustees Peter Francis Meggs of 70 Benwerrin Drive, East Burwood, Victoria, retired, to send the particulars to the trustee by

the 20 October 1999 after which date the trustee may convey or distribute the assets, having regard only to the claims of which the trustee then has notice.

ROBERTS PARTNERS,
216 Main Street, Mornington.

ARTHUR JOHN LORD, late of Unit 41, Wantirna Retirement Village, 2 Old Stud Road, Wantirna, Victoria, retired, deceased. Creditors, next of kin and others having claims in respect of the estate of the deceased who died on 13 March 1999 are required to send particulars of their claims to the executor Permanent Trustee Company Limited of 294-296 Collins Street, Melbourne by 31 October 1999 after which date the executor may convey or distribute the assets having regard only to the claims of which it may then have notice.

WILLS & PROBATE VICTORIA, lawyers,
Level 5, 360 Little Bourke Street, Melbourne.

ELLEN MYRTLE PHYLLIS LANSTON, formerly of 26 Grandview Avenue, Burwood, but late of 80 Outer Crescent, Brighton, Victoria, home duties, deceased. Creditors, next-of-kin and others having claims in respect of the estate of the deceased, who died on 30 May 1999, are required by the executor, Thelma May Jones of Unit 5, 344 New Street, Brighton, to send particulars to the executor by 26 October 1999 after which date the executor intends to convey or distribute the assets of the estate having regard only to the claims of which the executor may have notice.

WISEWOULDS, solicitors,
459 Collins Street, Melbourne.

Unclaimed Moneys Act 1962

Register of Unclaimed Moneys held by the —

<i>Name of Owner on Books and Last Known Address</i>	<i>Total Amount Due to Owner</i>	<i>Description Of Unclaimed Money</i>	<i>Date when Amount first became Payable</i>
EDUCATION CREDIT UNION CO-OPERATIVE LIMITED			
\$			
Technical College Teachers' Association, Attention: Cliff Strachan, Cardigan Street, Carlton	132.00	Cheque	04/10/97
Ms Geraldine Ann Pancini, 550 Park St, Carlton North	787.50	"	26/12/97
MLC Life Limited, 459 Collins Street, Melbourne	131.19	"	13/03/98

99148

CONTACT: LUISA SANGIORGIO, PHONE: (03) 9854 4666.

Unclaimed Moneys Act 1962

Register of Unclaimed Moneys held by the —

<i>Name of Owner on Books and Last Known Address</i>	<i>Total Amount Due to Owner</i>	<i>Description Of Unclaimed Money</i>	<i>Date when Amount first became Payable</i>
LUTHER COLLEGE			
	\$		
Mr Chua Ah Seng and Mrs Wong Lang King, Lot 1100, Block 5, 9½ Jee Foh Road, Miri, Sarawak, Malaysia	300.00	Deposit	31/12/93
Ms Casey Churchward, Belmont Bay Caravan Park, Newcastle, NSW	500.00	"	31/12/95
Mr Raymond Keith and Mrs Dianne Rosemary Daniel, Lot 10, Don Road, Healesville	500.00	"	31/03/95
Mr Hong Muan Lin & Mrs Siew Kiaw Lim, 6 Angelica Crescent, Croydon Hills	500.00	"	31/12/94
Mr John Malcolm & Mrs Meredith Anne Lindsay, 51 Alexandra Road, Ringwood East	300.00	"	31/12/89
Mrs Barbara Waller, 55 Jeffrey Drive, Ringwood North	300.00	"	31/12/92
Mr Kwok Po Lung & Mrs Ying Chi Chi, H. K. Mansions, 17th Floor, Block Q, 1 Yee Woo Street, Causeway Bay, Hong Kong	500.00	"	31/12/91
Mr Richard Lai and Mrs Rosalie Chao, 9 Thomas Lawford Place, Croydon Hills	300.00	"	31/12/87
Mr Robert Tomas, P.O. Box 1762, Coffs Harbour, NSW	300.00	"	"

99156

CONTACT: MARK BREMNER, PHONE: (03) 9723 6155.

Unclaimed Moneys Act 1962

Register of Unclaimed Moneys held by the —

<i>Name of Owner on Books and Last Known Address</i>	<i>Total Amount Due to Owner</i>	<i>Description Of Unclaimed Money</i>	<i>Date when Amount first became Payable</i>
CASTRAN GILBERT			
	\$		
S. Dixon, 4/81 Edinburgh Street, Richmond	498.33	Cheque	27/07/97
K. Henry, 16/230 Albert Street, Brunswick	535.00	"	11/08/97
K. Rungihapom, 9/42 Eastbourne Street, Prahran	347.00	"	18/08/97
A. S. Wong, 5/37 Hope Street, South Yarra	126.41	"	05/09/97
Fandy & M. Yeoh, 2/193 Royal Parade, Parkville	658.00	"	02/10/97

1900 G 33 19 August 1999

Victoria Government Gazette

A. Chandak, 2/10 Devorgilla Avenue, Toorak	635.00	''	04/12/97
Mr G. Muys, 1/125 Walpole Street, Kew	193.00	''	03/03/98
Mr B. Beatty, 14/5 Evans Street, Brunswick	1,300.00	''	04/03/98
Mr Brian Rowe, 903/666 Chapel Street, South Yarra	903.87	''	''
Anita Alsop, 13/250 Dandenong Road	273.00	''	06/03/98

99153

CONTACT: CAREZ McCLEERY, PHONE: (03) 9826 87881.

Unclaimed Moneys Act 1962

Register of Unclaimed Moneys held by the —

<i>Name of Owner on Books and Last Known Address</i>	<i>Total Amount Due to Owner</i>	<i>Description Of Unclaimed Money</i>	<i>Date</i>
			<i>when Amount first became Payable</i>
NEVERFAIL SPRINGWATER CO PTY LTD			
	\$		
Tang Vo, 86 Adeney Avenue, Kew	120.00	Refund	02/06/97
Service Nominees, 42 Chapel Street, Fitzroy	100.00	''	09/07/97
Western Region, 36 Buckley Street, Footscray	100.00	''	21/07/97
Ansett Airlines, Ground Floor, Tullamarine Airport	455.00	''	22/08/97
O'Brien Glass, 801A Sydney Road, Brunswick	100.00	''	14/10/97
Midas Muffler, 495A Hampshire Road, Sunshine	100.00	''	16/12/97
Jet Tour, F7-140 Bourke Street, Melbourne	145.50	''	03/03/98
Australia Post, 23 Huntingdale Road, Burwood	213.00	''	17/03/98

99155

CONTACT: KEVIN MUNDAY, PHONE: (03) 9462 2277.

PROCLAMATIONS

**Rail Corporations and Transport Acts
(Amendment) Act 1999**

PROCLAMATION OF COMMENCEMENT

I, James Gobbo, Governor of Victoria, with the advice of the Executive Council and under section 2(2) of the **Rail Corporations and Transport Acts (Amendment) Act 1999**, fix 24 August 1999 as the day on which the following provisions of that Act come into operation—

- (a) Part 2 (except sections 6, 7, 12 and 15),
- (b) Part 3,
- (c) section 49.

Given under my hand and the seal of
Victoria on 17 August 1999.

(L.S.) JAMES GOBBO
 Governor
By His Excellency's Command

ALAN R. STOCKDALE
 Treasurer

**Rail Corporations (Further Amendment)
Act 1998**

PROCLAMATION OF COMMENCEMENT

I, James Gobbo, Governor of Victoria, with the advice of the Executive Council and under section 2(2) of the **Rail Corporations (Further Amendment) Act 1998**, fix 24 August 1999 as the day on which the remaining provisions of that Act come into operation.

Given under my hand and the seal of
Victoria on 17 August 1999.

(L.S.) JAMES GOBBO
 Governor
By His Excellency's Command

ALAN R. STOCKDALE
 Treasurer

Rail Corporations (Amendment) Act 1997
PROCLAMATION OF COMMENCEMENT

I, James Gobbo, Governor of Victoria, with the advice of the Executive Council and under section 2(2) of the **Rail Corporations (Amendment) Act 1997**, fix 24 August 1999 as the day on which section 37 of that Act comes into operation.

Given under my hand and the seal of
Victoria on 17 August 1999.

(L.S.) JAMES GOBBO
 Governor
By His Excellency's Command

ALAN R. STOCKDALE
 Treasurer

Fair Trading Act 1999

PROCLAMATION OF COMMENCEMENT

I, James Gobbo, Governor of Victoria, with the advice of the Executive Council and under section 2 of the **Fair Trading Act 1999**, fix 1 September 1999 as the day on which the remaining provisions of that Act come into operation.

Given under my hand and the seal of
Victoria on 17 August 1999.

(L.S.) JAMES GOBBO
 Governor
By His Excellency's Command

JAN WADE
 Minister for Fair Trading

**Fair Trading (Inspectors Powers and Other
Amendments) Act 1999**

PROCLAMATION OF COMMENCEMENT

I, James Gobbo, Governor of Victoria, with the advice of the Executive Council and under section 2 of the **Fair Trading (Inspectors Powers and Other Amendments) Act 1999**, fix 1 September 1999 as the day on which the remaining provisions of that Act come into operation.

Given under my hand and the seal of
Victoria on 17 August 1999.

(L.S.) JAMES GOBBO
 Governor
By His Excellency's Command

JAN WADE
 Minister for Fair Trading

Land Act 1958

PROCLAMATION OF ROAD

I, James Gobbo, Governor of Victoria acting with the advice of the Executive Council and under section 25(3)(c) of the **Land Act 1958** proclaim as road the following land:

MUNICIPAL DISTRICT OF THE
EAST GIPPSLAND SHIRE COUNCIL
BENDOCK — The land in the Parish of
Bendock shown by hatching on plan hereunder.
(B644[10]) — (16/L9-5266).

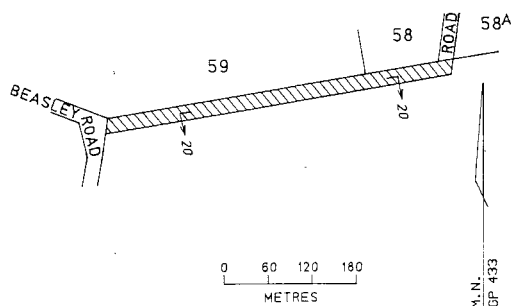

This Proclamation is effective from the date
on which it is published in the Government
Gazette.

Given under my hand and the seal of
Victoria on 17 August 1999.

(L.S.) JAMES GOBBO
Governor
By His Excellency's Command

MARIE TEHAN, MP
Minister for Conservation
and Land Management

HUME CITY COUNCIL
Road Discontinuance

At its meeting on 9 August 1999 and acting under clause 3 of schedule 10 to the **Local Government Act 1989** Hume City Council resolved to discontinue the road shown hatched on the plan below.

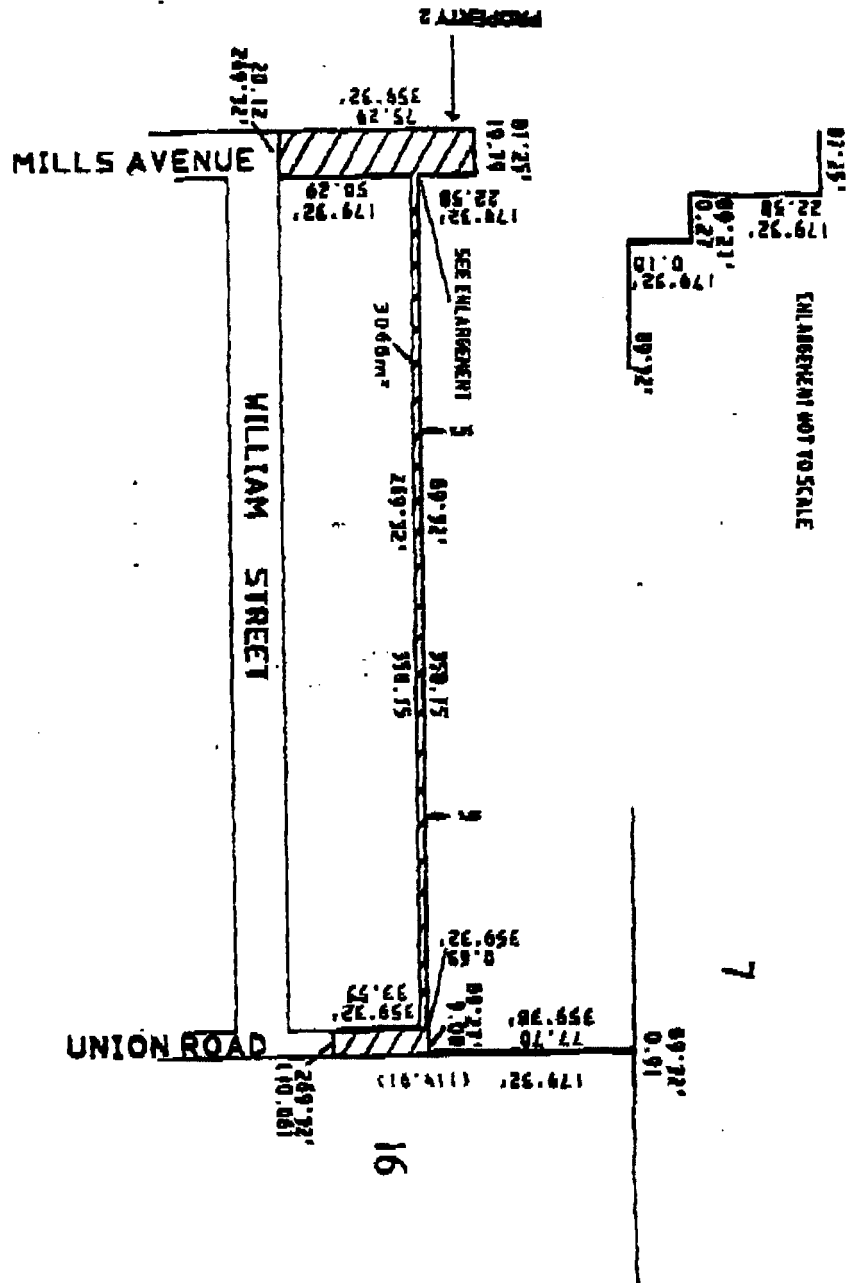

MR DARRELL TRELOAR
Chief Executive Officer

HOBSONS BAY CITY COUNCIL
Road Discontinuance

Under Section 206 and Schedule 10 Clause 3 of the Local Government Act 1989 the Hobsons Bay City Council at its Ordinary meeting held on 22 June, 1999, formed the opinion that the road shown hatched on the plan below is not reasonably required as a road for public use and has resolved to discontinue the road and to sell the land from the road by private treaty subject to any right, power or interest held by the Melbourne Water Corporation (City West Water Ltd.), in respect to the section of land marked E-1 on the plan, in the road in connection with any sewers, drains or pipes under the control of that authority in or near the road.

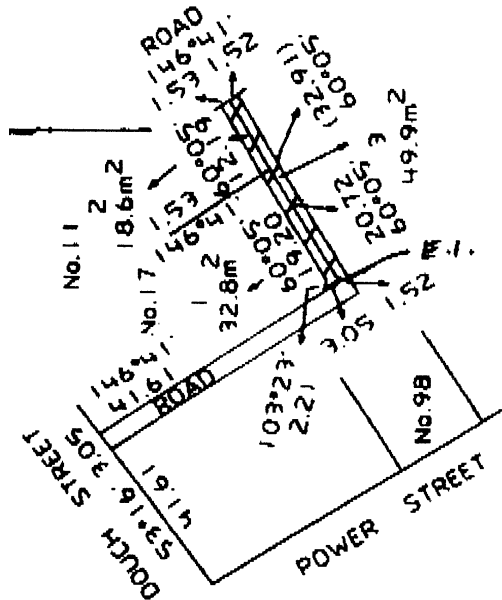

KEN McNAMARA
Chief Executive Officer

BRIMBANK CITY COUNCIL
Road Discontinuance

Under Section 206 and Schedule 10 Clause 3 of the Local Government Act 1989 the Brimbank City Council at its Ordinary meeting held on 13 July, 1999, formed the opinion that the road shown hatched and cross-hatched on the plan below is not reasonably required as a road for public use and has resolved to

discontinue the road and to sell the land from the road by private treaty subject to any right, power or interest held by the Brimbank City Council, in respect to the section of land cross-hatched on the plan (E-1) and the Melbourne Water Corporation (City West Water Ltd.) in respect to the section of land marked E-2 on the plan, in the road in connection with any sewers, drains or pipes under the control of those authorities in or near the road.

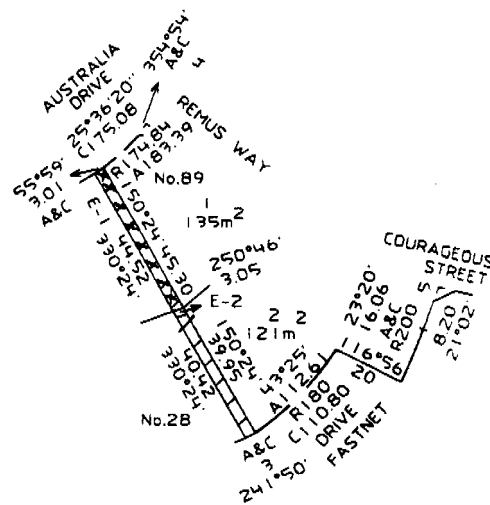

MARILYN DUNCAN
Chief Executive Officer

DAREBIN CITY COUNCIL
Road Discontinuance

Under Section 206 and Schedule 10 Clause 3 of the Local Government Act 1989 the Darebin City Council at its Ordinary meeting held on 21 December, 1998, formed the opinion that the road shown hatched and cross-hatched on the plan below is not reasonably required as a road for public use and has resolved to discontinue the road and to sell the land from the road by private treaty subject to any right, power or interest held by the Darebin City Council, in respect to the land shown hatched on the plan and the Melbourne Water Corporation (Yarra Valley Water Corporation (Yarra Valley Water Ltd.) in respect to the land shown hatched and cross-hatched on the plan, in the road in connection with any sewers, drains or pipes under the control of those authorities in or near the road.

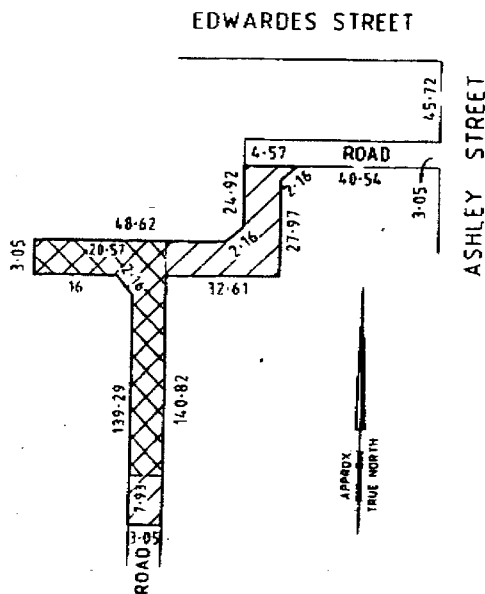

PHILIP SHANAHAN
Chief Executive Officer

CITY OF MELBOURNE
Declaration of Public Highway

“Under Section 204(1) of the **Local Government Act 1989**, the Group Manager Development and Statutory Services Melbourne City Council, acting on an Instrument of delegation authorised by the Melbourne City Council on 15 December 1998, determined to declare the land described in Deed No. 611 Book 840 registered in the Office of the Registrar General and known to Council as Corporation Lane No. 1589 at the rear of Nos. 76-82 Jolimont Street, Jolimont, to be a public highway for the purposes of the Act.”

Dated 10 August 1999.

MICHAEL MALOUF
Chief Executive Officer

YARRA CITY COUNCIL
Proposed Roads and Council Land
(Amendment) Local Law No. 9 and
Associated Footpath Trading Policy and
Guidelines

Notice is given that the Council proposes to make the Roads and Council Land (Amendment) Local Law No. 9 pursuant to the **Local Government Act 1989** (“the Act”) for the purposes of:

- (a) amending the Roads and Council Land Local Law No. 2;
- (b) imposing uniform requirements throughout the municipal district concerning the occupation of roads, footways or Council land for certain purposes;
- (c) making certain transitional arrangements; and
- (d) complying with clause 5 of the Competition Principles Agreement.

The general purport of the Local Law is that it:

- revokes clause 21 of the Roads and Council Land Local Law No. 2;
- prohibits the display of goods, the placement of advertising signs and the placement of seats, umbrellas, tables, chairs or other furniture on roads, footways or Council land in the absence of a Footpath Licence Agreement;
- requires a person who has placed or displayed goods, an advertising sign or a seat, umbrella, table, chair or other furniture on a road, footway or Council land to remove same if directed to do so by an authorised officer, a member of the Victoria Police or a member of an emergency service;
- has enforcement provisions which create offences and enable the use of notices to comply and the impounding of certain items left on a road, footway or Council land;
- provides a transitional provision relating to existing permits issued in accordance with clause 35 of the Roads and Council Lands Local Law No. 2.

A copy of the proposed Local Law and associated draft Footpath Trading Policy and Guidelines may be inspected at or obtained from the Richmond Town Hall, 333 Bridge Road, Richmond or the Collingwood Town Hall, 140 Hoddle Street, Abbotsford between the hours of 8.30 a.m. and 5.00 p.m. Monday to Friday.

Any person may make a written submission relating to the proposed Local Law. Submissions received by Monday 20 September 1999 will be considered in accordance with section 223 of the Act. Any person requesting to be heard in support of a written submission is entitled to appear before a meeting of the Planning & Community Development Committee on 19

October 1999 either personally or by a person acting on his or her behalf and will be notified of the time and date of hearing.

Submissions should be lodged at the above address or posted to the Council at P.O. Box 168, Richmond 3121. Inquiries should be directed to Mr Adrian Murphy, Co-ordinator, Community Amenity & Health.

STELVIO VIDO
Acting Chief Executive Officer

Planning and Environment Act 1987
GREATER DANDENONG PLANNING
SCHEME – LOCAL SECTION

Notice of Amendment
Amendment C5

The City of Greater Dandenong has prepared Amendment C5 to the Local Section of the Greater Dandenong Planning Scheme. The Amendment was placed on exhibition on 19 August 1999.

The Amendment affects land in the Keysborough area bounded generally by the Dingley Freeway reservation, Cheltenham Road, Springvale Road, the Mornington Peninsula Freeway, Patterson River and the Dandenong Creek.

The Amendment proposes to change Section 22 of the Planning Scheme by varying the Keysborough Non Urban Area Local Planning Policy to provide for:

- Hutton Road and Greens Road, plus dog and industrial buffer areas, as the southern limit to any potential for standard urban development (subject to compliance with specified development and environmental guidelines). An average 2 hectare minimum subdivision size to apply in all other parts of this sector.
- Retention of an open rural landscape character in the area between Hutton/Greens Roads and the Mordialloc Creek, with an average 2 hectare minimum subdivision size.
- Retention of a broadscale farming character south of the Mordialloc Creek, with maintenance of the existing minimum average subdivision size of 40 hectares.

The Amendment also varies Section 21 of

the Planning Scheme, the Municipal Strategic Statement, to provide the descriptive basis for the changes to the Keysborough Policy.

The Amendment can be inspected at (1) The City of Greater Dandenong, Springvale Office, 397-405 Springvale Road, Springvale; Dandenong Office, 39 Clow Street, Dandenong; Customer Centre, Shop A7, Parkmore Shopping Centre, Keysborough; (2) The Department of Infrastructure, Ground Floor, Nauru House, 80 Collins Street, Melbourne.

Submissions about the Amendment must be sent to: The Manager, Planning and Physical Services, City of Greater Dandenong, P.O. Box 200, Springvale 3171 by Friday 1 October 1999.

BRUCE McCONCHIE
Business Unit Leader Urban Planning
City of Greater Dandenong

Planning and Environment Act 1987
MOONEE VALLEY PLANNING SCHEME

Notice of Amendment
Amendment C4

The City of Moonee Valley has prepared Amendment C4 to the Moonee Valley Planning Scheme.

The Amendment proposes to include 150 buildings of historical and architectural importance in the Moonee Valley Planning Scheme.

Land which is affected by the new planning controls will be shown on the planning scheme maps Nos. HO7, HO8, HO11, HO12, HO14, HO15 and HO16.

A copy of the Amendment may be inspected at the following locations during office hours: City of Moonee Valley Town Planning Department, corner Kellaway Avenue & Pascoe Vale Road, Moonee Ponds and Department of Infrastructure, Customer Service Centre, Upper Plaza, Nauru House, 80 Collins Street, Melbourne.

Submissions about the Amendment must be sent to: Attention: Geoff Rundell, Executive Manager, Corporate & Strategic Planning, City of Moonee Valley, P.O. Box 126, Moonee Ponds 3039 by 1 October 1999.

LINDSAY MERRITT
Chief Executive

Planning and Environment Act 1987

BALLARAT PLANNING SCHEME

Notice of Amendment

Amendment No C17

The City of Ballarat has prepared Amendment No C17 to the Ballarat Planning Scheme.

The amendment proposes to introduce a range of controls over new residential development within areas identified as being of significant urban character under the Ballarat Urban Character Study. The purpose of the proposed controls is to ensure that all new development is undertaken in a manner which is sympathetic with the existing character of the surrounding area. These controls will be introduced through the introduction of Design and Development Overlays and a Vegetation Protection Overlay.

Twelve specific locations are to be covered by these two overlays with the locations generally being within the area south of Gregory Street, east of Gillies Street, north of Latrobe Street and west of Skipton Street and Peel Street North.

The Amendment can be inspected at any of the following locations: City of Ballarat, Watershed Office, (Grenville Street South, Ballarat); Department of Infrastructure, Central Highlands and Wimmera Regional Office, 1315 Sturt Street, Ballarat; and Department of Infrastructure, Nauru House, 80 Collins Street, Melbourne.

Submissions about the amendment must be sent to the Chief Executive Officer, City of Ballarat, P.O. Box 655, Ballarat, Vic 3353, and will be accepted until 5.00 pm September 20, 1999. All submissions should clearly state all of the grounds on which you support or oppose the amendment and indicate whether you wish to be heard in respect of the submission at any subsequent panel hearing.

JOHN McLEAN
Chief Executive Officer

Planning and Environment Act 1987

HOBSONS BAY PLANNING SCHEME

Notice of Preparation of Amendment to a
Planning Scheme

Amendment L16

The Hobsons Bay City Council has prepared amendment L16 to the Hobsons Bay Planning Scheme.

The land affected by the amendment is 1-3 Johnson St, Newport.

The amendment proposes to rezone the subject land from a Light Industrial (Williamstown) Zone to Residential 1 Zone with Potentially Contaminated Land (PCLO) and Design & Development (DDO) overlay.

The amendment, including copies of the explanatory report, maps and the Potentially Contaminated Land Design & Development Overlays to be inserted into the scheme may be inspected at: Hobsons Bay City Council, Altona Office, 115 Civic Parade, Altona 3018; Williamstown, Laverton, Newport and Altona Libraries; the Department of Infrastructure Customer Service Centre, Level 3 Plaza, Nauru House, 80 Collins St, Melbourne 3000; and any person who may be affected by the amendment may make a submission to the planning authority, the Hobsons Bay City Council.

Submissions to the amendment must be sent to Mr Ken McNamara, Chief Executive Officer, Hobsons Bay City Council, PO Box 21, Altona, Vic 3018 by Friday September 17, 1999.

KEN McNAMARA
Chief Executive Officer

Planning and Environment Act 1987

GREATER GEELONG PLANNING SCHEME

Notice of Amendment

Amendment R243

The Minister for Planning and Local Government has prepared Amendment R243 to the Greater Geelong Planning Scheme.

The Amendment proposes to amend the Regional Section of the Greater Geelong Planning Scheme to introduce a new Special Use 16 zone to provide for the development of the Geelong International Watersports Park on Belmont Common; and relocate a proposed high-level road crossing at Breakwater which avoids the proposed watersports course.

The Amendment can be inspected at City of Greater Geelong, 2nd Floor, 103 Corio Street, Geelong; Department of Infrastructure, Office of Planning, 63 McKillop Street, Geelong 3220 and Department of Infrastructure, Level 3 Plaza, Nauru House, 80 Collins Street, Melbourne 3000.

Enquiries about technical aspects of the project should be directed to Peter Jeffreys, City of Greater Geelong, Ph: 5227 0821 whilst planning issues and processes can be discussed with Ian McCartney, City of Geelong, Ph: 5227 0842 or Geoff Forbes, Department of Infrastructure, Ph: 5225 2547.

Submissions about the Amendment must be sent to the Office of Planning, Department of Infrastructure, PO Box 576, Geelong 3220 by Monday, 20 September 1999.

KIM McGOUGH
Regional Manager

Creditors, next of kin and others having claims against the estate of any of the undermentioned deceased persons are required to send particulars of their claims to State Trustees Limited, A.C.N 064 593 148, 168 Exhibition Street, Melbourne, Victoria, 3000 the personal representative, on or before October 20, 1999 after which date State Trustees Limited may convey or distribute the assets having regard only to the claims of which State Trustees Limited then has notice.

BOGDANOVIC, Dragoltjub, late of 132/159 Melrose Street, North Melbourne, pensioner, who died May 11, 1999.

BRIEN, Florence Maude, late of 2/13 Essex Road, Surrey Hills, pensioner, who died April 15, 1999.

CHAFFEY, Michael Adrian, late of 81 Victoria Crescent, Abbotsford, public servant, who died March 24, 1999.

COOPER, Ruby, formerly of 224 Nott Street, Port Melbourne, but late of Napier Street Hostel, 179 Napier Street, South Melbourne, pensioner, who died July 30, 1999.

MURDOCH, Kirkland Routledge Clark, late of Dalkeith Hostel, Marie Street, Traralgon, labourer, who died September 14, 1998.

NIXON, Leslie Francis, formerly of 2 McCubbin Court, Sunbury, but late of Abbey Court Hostel, 98 Horne Street, Sunbury, retired, who died May 9, 1999.

NOKES, William Howard, late of 25 Queens Parade, Burwood, retired, who died July 29, 1999.

REED, Dorothy Margaret, formerly of 5 Peterleigh Grove, Essendon, but late of

Westgate Private Nursing Home, 4 William Street, Newport, pensioner, who died October 7, 1998.

WILLIAMS, Muriel Rebecca, late of 20 Joffre Avenue, Edithvale, home duties, who died April 6, 1998.

WILSON, Gwynne Usherwood, late of 45 Heathfield Rise, Box Hill North, retired, who died May 3, 1999.

Dated at Melbourne, 10 August 1999.

CATHY VANDERFEEN
Manager, Estate Management
State Trustees Limited

Creditors, next of kin and others having claims against the estate of any of the undermentioned deceased persons are required to send particulars of their claims to State Trustees Limited, A.C.N 064 593 148, 168 Exhibition Street, Melbourne, Victoria, 3000 the personal representative, on or before October 23, 1999 after which date State Trustees Limited may convey or distribute the assets having regard only to the claims of which State Trustees Limited then has notice.

ANGWIN, Patricia Dorothy, late of Flat 29, 77 Queens Road, Melbourne, retired, who died July 4, 1999.

BLACK, David, late of 25 Staughton Street, Melton South, pensioner, who died June 2, 1999.

BRENT, Elaine Beryl Jean, late of Rotary Village Hostel, Elliot Street, Reservoir, retired, who died June 2, 1999.

DOWNEY, Samuel William John, 68 Cityview Road, Balwyn, 52-54 George Street, East Doncaster, pensioner, who died July 29, 1999.

KEON, Ann Boyle, late of 4/51 Denham Street, Hawthorn, pensioner, who died May 5, 1999.

KICIA Barbara, late of 10 Avon Street, Geelong West, home duties, who died April 12, 1996.

McINNES, Patricia, late of Eaglemont Private Nursing Home, 25 Thoresby Grove, Ivanhoe, pensioner, who died December 9, 1996.

PERRIN, Jeannette Rose May, late of Roseden Private Nursing Home, 1 Royton Street, Burwood East, Victoria, pensioner, who died May 28, 1999.

ROSE, Lilian May, late of Ann Nichol House, 80 Willis Street, Port Arlington, retired, who died June 8, 1999.

SHARP, Elsie May, late of Monash Gardens Hostel, 355 Wellington Road, Mulgrave, retired, who died July 1, 1999.

SKINNER, Alfred Francis, late of 5/13 Webb Street, Seaford, pensioner, who died April 29, 1999.

WENZEL, Arthur Leonard, late of Caulfield Hospital, 294 Kooyong Road, Caulfield, pensioner, who died May 1, 1999.

WINTER, Patrick Kenneth, late of 33 Baird Street, Mulgrave, retired, who died June 5, 1999.

Dated at Melbourne, 14 August 1999.

CATHY VANDERFEEN
Manager, Estate Management
State Trustees Limited

Creditors, next-of-kin and others having claims against the following estates:-

BAMBALIS, Georgina, late of Unit 23, Kew Residential Services, Princess Street, Kew, Victoria, pensioner, deceased intestate, who died April 9, 1999.

BENTON Jean, late of 162/49 Union Street, Prahran, Victoria, pensioner, deceased intestate, who died July 11, 1999.

CRABB, Richard Thomas, late of Unit 4, 226 Jasper Road, McKinnon, Victoria, retired, deceased, who died August 18, 1998.

EAGAR, Raymond, late of 52 Victoria Road, Bayswater, Victoria, retired, deceased intestate, who died May 2, 1999.

FULLWOOD, Ann, late of H & C CRU, 40 Westall Street, Thomastown, Victoria, retired, deceased intestate, who died July 25, 1999.

KIRBY, John James, late of Glenhuntly Park Private Nursing Home, 5 Maroona Road, Glenhuntly, Victoria, pensioner, deceased intestate, who died July 10, 1999.

McCORMACK, James, late of Margaret Lodge, 52 Barkly Street, St. Kilda, Victoria, pensioner, deceased intestate, who died April 24, 1999.

Creditors, next-of-kin and others having claims against the abovementioned estates are

required pursuant to Section 33 of the **Trustee Act 1958** to send particulars of their claims against the abovementioned estates to State Trustees Limited, 168 Exhibition Street, Melbourne, Victoria, on or before October 23, 1999 after which date State Trustees Limited, A.C.N. 064 593 148, may convey or distribute the assets of the abovementioned estates having regard only to the claims of which it then has notice.

Department of Treasury and Finance

SALE OF CROWN LAND
BY PUBLIC AUCTION

Date of Auction: 4 September 1999 at 2.00p.m. on site.

Reference: 98/02966.

Address of Property: Henry Street, Greensborough.

Crown Description: Crown Allotment 17J, Section 17, County of Bourke, Parish of Keelbundora.

Terms of Sale: Deposit 10%, Balance 60 days.

Area: 2,607m²

Officer Co-ordinating Sale: Kathy Wylie, Victorian Government Property Group, Department of Treasury and Finance, 10/1 Macarthur Street, Melbourne, Vic 3002.

Selling Agent: Darren Jones Real Estate Pty Ltd, The Professionals, 94 Grimshaw Street, Greensborough, Vic 3088.

ROGER M. HALLAM
Minister for Finance

FORM 7

S.21
Reg.16

NOTICE OF ACQUISITION

Compulsory Acquisition of Interest in Land

Road Corporation (VicRoads) declares that by this notice it acquires the following interest in the land described as part of Crown Allotment 14, Section C and Crown Allotments 22, 22a and 23 Section A, Parish of Tcherter comprising 1.53 hectares and being land described in Certificate of Title Volume 4129 Folio 249, shown as parcels 3,4 & 5 on VicRoads Survey Plan 19137.

Interest acquired: That of Anthony Gerrard & Donna Maree **MASON** & Bernard James & Maureen Veronica **MASON** and all other interests.

Published with the authority of VicRoads.

The survey plan referred to in this notice may be viewed at the office of Property Services Department, VicRoads, 60 Denmark Street, Kew.

Date: 19 August 1999.

For and on behalf of VicRoads:
T. H. HOLDEN,
Manager Property Services Department.

FORM 7 S.21
Reg.16

NOTICE OF ACQUISITION

Compulsory Acquisition of Interest in Land

Roads Corporation (VicRoads) declares that by this notice it acquires the following interest in the land described as part of Crown Allotment 29, Section C, Parish of Tchuter comprising 4646 square meters and being land described Certificate of Title Volume 7610 Folio 042, shown as parcel 2 on VicRoads Survey Plan 19137.

Interest acquired: That of Raymond Stanley **SHAY** and all other interests.

Published with the authority of VicRoads.

The survey plan referred to in this notice may be viewed at the office of Property Services Department, VicRoads, 60 Denmark Street, Kew.

Date: 19 August 1999.

For and on behalf of VicRoads:
T. H. HOLDEN,
Manager Property Services Department.

Subordinate Legislation Act 1994

Electricity Safety Act 1998

ELECTRICITY SAFETY (NETWORK ASSETS) REGULATIONS 1999

Notice of Regulatory Impact Statement

In accordance with the **Subordinate Legislation Act 1994**, notice is given that a Regulatory Impact Statement has been prepared in relation to the proposed Electricity Safety (Network Assets) Regulations 1999.

The proposed regulations will be made under sections 149, 151 and 157 of the **Electricity Safety Act 1998**.

The primary objective of the proposed regulations is to protect personnel and property from risk and damage associated with network assets of the upstream network of the electricity supply system and the supply network of a railway or tramway system. The proposed regulations prescribe standards for the design, construction, operation and maintenance of network assets; protect persons from risk and property from damage associated with network assets; and protect and prevent interference with network assets.

The Regulatory Impact Statement examines the appropriate level of regulation so that there is an improvement of safety performance for the generation, transmission, distribution and supply of electricity. The Regulatory Impact Statement concludes that the proposed regulated scheme provides the most cost effective means of achieving the objectives and provides for the protection of people and property.

A copy of the Regulatory Impact Statement and the proposed Regulations can be obtained from the Office of the Chief Electrical Inspector, Level 3, 4 Riverside Quay, Southbank or by telephoning (03) 9203 9700.

Public comments and written submissions are invited and will be received up to 28 days from the date of publication of this notice.

Submissions should be addressed to: Mr Bill Greenland, General Manager Supply Safety, Office of the Chief Electrical Inspector, P.O. Box 262, Collins Street West, Victoria 8007.

ALAN R. STOCKDALE
Treasurer

Subordinate Legislation Act 1994

NOTICE OF DECISION

Fisheries (Abalone) Regulations 1999

I, Patrick McNamara, Minister for Agriculture and Resources, and Minister responsible for the administration of the **Fisheries Act 1995**, give notice under section 12 of the **Subordinate Legislation Act 1994**, as follows –

A Regulatory Impact Statement (RIS) was prepared in relation to the proposed Fisheries

(Abalone) Regulations 1999 and advertised inviting public comment. Thirty-five submissions were received and have been considered.

I have decided that the proposed Regulations should be made with the following major amendments –

- (a) removal of closed seasons for abalone;
- (b) removal of a recreational abalone bag limit of 5 (including 2 greenlip abalone) with the effect of maintaining the current level of 10 abalone (including 2 greenlip abalone);
- (c) amendment of maximum boat and car or other vehicle possession limits applicable to recreational fishers. The proposal to impose a group possession limit of 20 abalone on a boat or car or other vehicle carrying 4 or more persons has been amended to 50 abalone on a boat or car or other vehicle carrying 5 or more persons;
- (d) creation of a requirement that recreational fishers be required to cut abalone meat in a certain manner and that the cut abalone be retained in its shell until immediately prior to cooking;
- (e) creation of an offence to take abalone between sunrise and sunset on the following day.

Dated 16 August 1999.

PAT McNAMARA
Minister for Agriculture and Resources

Water Act 1989

CENTRAL HIGHLANDS REGION WATER AUTHORITY

I, Suzanne Evans, Acting Director, Water Agencies, Department of Natural Resources and Environment, as the delegate of the Minister for Agriculture and Resources, make the following Order:

DECLARATION OF THE CLUNES SEWERAGE DISTRICT ORDER 1999

1. This Order is called the Declaration of the Clunes Sewerage District Order 1999.
2. This Order is made under Section 96(11)(a) of the **Water Act 1989** and all other available powers.

3. This Order takes effect from the date it is published in the Government Gazette.
4. The proposal for the declaration of a new sewerage district submitted to the Department of Natural Resources and Environment by the Central Highlands Region Water Authority on 23 June 1999 is approved.
5. (a) A new sewerage district is declared;
- (b) The new sewerage district is called the Clunes Sewerage District;
- (c) The Clunes Sewerage District is the area of land within the red border on the accompanying plan No. 5817, a copy of which may be inspected at the offices of the Central Highlands Region West Water Authority, situated at 7 Learmonth Road, Wendouree, Victoria; and
- (d) The Central Highlands Region Water Authority is nominated to manage and control the Clunes Sewerage District.

Corr. No. 95/0156-1

Dated 12 July 1999.

SUZANNE EVANS
Acting Director, Water Agencies
Department of Natural Resources
and Environment
(as delegate of the Minister for
Agriculture and Resources)

Marine Act 1988

ORDER DECLARING PERSONS OR BODIES TO BE LOCAL AUTHORITIES IN RESPECT TO SPECIFIED STATE WATERS

Amending Order

Pursuant to Section 3(3)(b) of the **Marine Act 1988** and pursuant to Section 41A of the **Interpretation of Legislation Act 1984** the order made under section 3(3)(b) of the Marine Act and published in the Government Gazette on 2 July 1998 (G26 commencing on Page 1818) is hereby amended as follows -

1. In Part 3 in Column 1 delete "The Lake Wallace Foreshore Committee of Management Inc." and in Column 2 delete "Lake Wallace".
2. In Part 1 after Warrnambool City Council in Column 1 insert "West Wimmera Shire Council" and opposite in Column 2 insert "Lake Wallace".

3. In Part 3 in Column 2 opposite "Gippsland Ports Committee of Management Inc.", after "Designated Port of Mallacoota" insert "Shallow Inlet".

Dated 12 May 1999.

GEOFF CRAIGE
Minister for Roads and Ports

Road Safety Act 1986

MOTOR CYCLE RELIABILITY TRIAL

Under section 68(3) of the **Road Safety Act 1986**, I declare that sub-sections (1) and (2) of section 68 of the Act shall not apply with respect to the event to be conducted by the East Malvern Motorcycle Club Inc. on sections of road within the Mullundung Forest District on 22 August 1999 between the hours of 8.00 a.m. and 4.00 p.m.

Dated 13 August 1999.

N. R. BUTLER
Regional Manager
VicRoads – Eastern Victoria
delegate of the Minister for Roads and Ports

Meat Industry Act 1993

DIRECTION UNDER SECTION 46(2)

I, Patrick McNamara, being the Minister responsible for the administration of the **Meat Industry Act 1993** do hereby direct the Victorian Meat Authority to issue to Colac Otway Shire Council a Licence to Operate Local Abattoir and a Licence to Operate Further Meat Processing Facility for the Colac Abattoir from 14 August 1999 to 31 March 2000.

Dated 12 August 1999.

PATRICK McNAMARA, MP
Minister for Agriculture and Resources

Land Act 1958

Notice is hereby given that Optus Mobile Pty Ltd has applied to NRE for a lease under section 134 of the Land Act 1958 over allotments 10^A and 10^C, County of Polwarth, Parish of Angahook, for the purpose of a Mobile Telecommunications facility for a term of 20 years.

Transport Act 1983

TOW TRUCK DIRECTORATE OF VICTORIA

TOW TRUCK APPLICATIONS

Notice is hereby given that the Licensing Authority will consider the following application/s after 22 September 1999.

Notice of any objection to the granting of an application should be forwarded to reach the Director, Tow Truck Directorate of Victoria, Level 6, 14-20 Blackwood Street, North Melbourne (PO Box 666, North Melbourne 3051) not later than 16 September 1999.

It will not be necessary for interested parties to appear on the date specified, unless advised in writing.

Modern Towing & Salvage (Holdings) Pty Ltd

Application for variation of conditions of tow truck licence numbers TOW480 and TOW850 which authorise the licensed tow trucks to be managed, controlled and operated from a depot situated at 77 High Street, Melton to change the depot address to 6 Norton Drive, Melton.

H & S Dempsey

Application for variation of conditions of two truck licence number TOW646 which authorise the licensed tow truck to be managed, controlled and operated from a depot situated at 104 White Street, Mordialloc to change the depot address to 67 Osborne Avenue, Springvale.

Note: This licence is under consideration for transfer to C. Mack.

Dated 19 August 1999

TERRY O'KEEFE
Director



Heritage
VICTORIA

Heritage Act 1995

NOTICE OF REGISTRATION

As Executive Director for the purpose of the Heritage Act, I give notice under section 46 that the Victorian Heritage Register is amended by including the Heritage Register Number 1802 in the category described as a Heritage Place:

Marion Terrace, 14-24 Burnett Street, St. Kilda, Port Phillip City.

EXTENT:

1. All the buildings marked B1 to B6 on Diagram 605393 held by the Executive Director.
2. All of the land marked L1 to L6 on Diagram 605393 held by the Executive Director being all of the land described in Certificates of Title Volume 8325 Folio 399; Volume 8214 Folio 341; Volume 8366 Folio 234; Volume 8179 Folio 232; Volume 8542 Folio 514; and Volume 8325 Folio 398.

Dated 5 August 1999.

RAY TONKIN
Executive Director



Heritage
VICTORIA

Heritage Act 1995

NOTICE OF REGISTRATION

As Executive Director for the purpose of the Heritage Act, I give notice under section 46 that the Victorian Heritage Register is amended by including the Heritage Register Number 8 in the category described as a Heritage Place is now described as:

St Patrick Cathedral Precinct, Cathedral Place, East Melbourne, Melbourne City Council.

EXTENT:

1. All of the land marked L1 on Diagram 601951A held by the Executive Director, being all of the land described in Certificates of Title Volume 2209 Folio 644, Volume 2394 Folio 704, Volume 2209 Folio 677 and Volume 3694 Folio 694.
2. All the buildings, including, all the fences and hard landscaping, the Cathedral marked B1, the Sacristy B2, the remnant tower of St Patrick's College B3, the offices B4, the Presbytery B5, B6 the statue of Daniel O'Connell and B7 the statue of Archbishop Daniel Mannix on Diagram 601951A held by the Executive Director.
3. The following objects: pair of Blackwood credence tables, Wardell; Blackwood Faldstool,

Wardell; Pair of brass Sanctuary lamps, Wardell; Brass Eagle lectern, Wardell; Pair of brass gasoliers to either side of original sanctuary, Wardell; The brass sanctuary Gong, Wardell; 2 gold chalices, Wardell; The Monstrance, Wardell; Pectoral Cross, Wardell.

Dated 5 August 1999.

RAY TONKIN
Executive Director



Heritage
VICTORIA

Heritage Act 1995

NOTICE OF REGISTRATION

As Executive Director for the purpose of the Heritage Act, I give notice under section 46 that the Victorian Heritage Register is amended by including the Heritage Register Number 26 in the category described as a Heritage Place is now described as:

Brassey House, 111 Chapman Street, North Melbourne, Melbourne City Council.

EXTENT:

1. All the building known as Brassey House B1 marked on Diagram 26 held by the Executive Director
2. All the land marked L1 on Diagram 26 held by the Executive Director, being the land described in Certificate of Title Volume 9409 Folio 509.

Dated 5 August 1999.

RAY TONKIN
Executive Director



Heritage
VICTORIA

Heritage Act 1995

NOTICE OF REGISTRATION

As Executive Director for the purpose of the Heritage Act, I give notice under section 46 that the Victorian Heritage Register is amended by including the Heritage Register Number 1803 in the category described as a Heritage Place is now described as:

Williamstown Botanic Gardens, Osborne Street, Williamstown, City of Hobsons Bay.

EXTENT:

1. All the structures marked as follows on Diagram 1803 held by the Executive Director:

B1 Entrance Gates (1907)

B2 A. T. Clarke statue (1891)

B3 Drinking Fountain (1906)

B4 Flagpole

B5 Pond

B6 Eight iron stanchions

B7 Four metal hoops

B8 Open Air Bandstand

B9 Four iron stanchions

2. All of the paths marked as follows on Diagram 1803 held by the Executive Director:

P1 Main Path

P2 Path (north-south)

P3 Paths

3. All the plants marked as follows on Diagram 1803 held by the Executive Director:

T1 *Washingtonia robusta* avenue x 28

T2 *Washingtonia robusta* stand x 5

T3 *Washingtonia filifera*

T4 *Washingtonia robusta* x 4

T5 *Phoenix canariensis* row x 7

T6 *Phoenix canariensis* row x 12

T7 *Phoenix canariensis* row x 4

T8 *Butia capitata* x 2

T9 *Ulmus procera* avenue x 15

T10 *Ficus macrophylla* x 16

T11 *Crinum asiaticum*

T12 *Cupressus sempervirens* (wide form)

4. all of the land known as the Williamstown Botanic Gardens and the L. A. Parker Reserve (pinetum) being Crown Reserve RS 2076, permanently reserved for Public Park and Recreation Purposes marked L1 on Diagram 1803 held by the Executive Director.

Dated 5 August 1999.

RAY TONKIN
Executive Director



Heritage
VICTORIA

Heritage Act 1995

NOTICE OF REGISTRATION

As Executive Director for the purpose of the Heritage Act, I give notice under section 46 that the Victorian Heritage Register is amended in that the Heritage Register Number 28 in the category described as a Heritage Place is now described as:

Residence, 206 Clarendon Street, East Melbourne, Melbourne City Council.

EXTENT:

1. All of the building known as Residence 206 Clarendon Street B1, marked on diagram 28 held by the Executive Director.

2. All the land marked L1 on Diagram 28 held by the Executive Director, being the land described in Certificate of Title Vol. 5596 Fol. 159, as Crown Allotment Eleven, Section Six, City of South Melbourne, Parish of Melbourne South County of Bourke.

Dated 5 August 1999.

RAY TONKIN
Executive Director



Heritage
VICTORIA

Heritage Act 1995

NOTICE OF REGISTRATION

As Executive Director for the purpose of the Heritage Act, I give notice under section 46 that the Victorian Heritage Register is amended in that the Heritage Register Number 22 in the category described as a Heritage Place is now described as:

Former London Chartered Bank, 88-90 Bourke Street and 156 Exhibition Street, Melbourne, Melbourne City Council.

EXTENT:

1. All of the building known as the former London Chartered Bank, 90 Collins Street, marked B1 on Diagram 603144 held by the Executive Director.

2. All the land marked L1 on Diagram 603144 held by the Executive Director, being the land described in Certificate of Title Vol. 10388 Fol. 305.

Dated 5 August 1999.

RAY TONKIN
Executive Director



Heritage
VICTORIA

Heritage Act 1995

NOTICE OF REGISTRATION

As Executive Director for the purpose of the Heritage Act, I give notice under section 46 that the Victorian Heritage Register is amended in that the Heritage Register Number 29 in the category described as a Heritage Place is now described as:

Clarendon Terrace, 208-212 Clarendon Street, East Melbourne, Melbourne City Council.

EXTENT:

1. All of the building known as Clarendon Terrace B1, former Stables B2, Fence B3 and Wall B4 marked on Diagram 29 held by the Executive Director.

2. All the land marked L1 on Diagram 29 held by the Executive Director, being the land described in Certificate of Title Vol. 7341 Fol. 129 as Crown Allotment 20, Section 10 at East Melbourne, City of Melbourne, Parish of Melbourne North, County of Bourke.

Dated 5 August 1999.

RAY TONKIN
Executive Director



Heritage
VICTORIA

Heritage Act 1995

NOTICE OF REGISTRATION

As Executive Director for the purpose of the Heritage Act, I give notice under section 46 that the Victorian Heritage Register is amended in that the Heritage Register Number 17 in the

category described as a Heritage Place is now described as:

Former Presbyterian Manse, 101 Rathdowne Street, Carlton, Melbourne City Council.

EXTENT:

1. All of the building known as the former Presbyterian Manse B-1, former Stables B2 and Gate Posts and Gate B3 marked on Diagram 17 held by the Executive Director.

2. All the land marked L1 on Diagram 17 held by the Executive Director, being the land described in Certificate of Title Vol. 9686 Fol. 291, Lot 4 on Plan of Subdivision No. 145437, Parish of Jika Jika, County of Bourke.

Dated 5 August 1999.

RAY TONKIN
Executive Director



Heritage
VICTORIA

Heritage Act 1995

NOTICE OF REGISTRATION

As Executive Director for the purpose of the Heritage Act, I give notice under section 46 that the Victorian Heritage Register is amended in that the Heritage Register Number 23 in the category described as a Heritage Place is now described as:

Royal Arcade, 331-337 Bourke Street, Melbourne, Melbourne City Council.

EXTENT:

1. All the building known as Royal Arcade including verandahs marked B1 on Diagram 23 held by the Executive Director.

2. All the land marked L1 on Diagram 23 held by the Executive Director, being the land described in Certificate of Title Vol. 10022 Fol. 456-498, strata plan SP 35729.

3. All the objects held within Royal Arcade as listed below:

*Gog and Magog Sculptures

*Gaunts Clock

Dated 5 August 1999.

RAY TONKIN
Executive Director

COMMONWEALTH OF AUSTRALIA

Petroleum (Submerged Lands) Act 1967

Notice of Grant of Exploration Permit

A permit numbered VIC/P43 has been granted Boral Energy Resources Limited, 60 Hindmarsh Square, Adelaide, South Australia 5000, Woodside Energy Limited, 1 Adelaide Terrace, Perth, Western Australia, 6000 and CalEnergy Gas (UK) Limited, 60 Grays Inn Road, London WC1 X8LT, United Kingdom, in respect of the blocks described hereunder, to have effect for a period of six years from and including the 11 August 1999.

DESCRIPTION OF BLOCKS

The graticular blocks numbered hereunder-

BLOCK NO.	BLOCK NO.	BLOCK NO.	BLOCK NO.
2365 part	2366 part	2435	2436
2437	2438 part	2439 part	2440 part
2441 part	2506	2507	2508
2509	2510	2511	2512
2513 part	2514 part	2578	2579
2580	2581	2682	2583
2584	2585	2586	2650
2651	2652	2653	2654
2655	2656	2657	2658
2722	2723	2724	2725
2726	2727	2728	2729
2730	2794 part	2795 part	2796 part
2797 part	2798 part	2799 part	2800
2801 part	2802 part		

on the Hamilton Offshore Graticular Sections Map.

Dated 11 August 1999.

Made under the **Petroleum (Submerged Lands) Act 1967** of the Commonwealth of Australia.

PATRICK McNAMARA
Designated Authority

COMMONWEALTH OF AUSTRALIA

Petroleum (Submerged Lands) Act 1967

Notice of Grant of Exploration Permit

A permit numbered VIC/P44 has been granted Strike Oil NL, Level 10, International House, 26 St Georges Terrace, Perth, Western Australia, 6000, in respect of the blocks described hereunder, to have effect for a period of six years from and including the 11 August 1999.

DESCRIPTION OF BLOCKS

The graticular blocks numbered hereunder-

BLOCK NO.	BLOCK NO.	BLOCK NO.	BLOCK NO.
2068 part	2069 part	2237 part	2138 part
2139 part	2140 part	2141 part	2142 part
2143 part	2209	2210	2211
2212	2213	2214	2215 part
2216 part	2217 part	2282	2283
2284	2285	2286	2287

2288	2289 part	2290 part	2291 part
2356	2357	2358	2359
2360	2361	2362	2363 part
2429	2430	2431	2432
2433	2434	2503	2504
2505			

on the Hamilton Offshore Graticular Sections Map.

Dated 11 August 1999.

Made under the **Petroleum (Submerged Lands) Act 1967** of the Commonwealth of Australia.

PATRICK McNAMARA
Designated Authority

Planning and Environment Act 1987

BELFAST PLANNING SCHEME
Notice of Approval of Amendment

Amendment L 17

The Minister for Planning and Local Government has approved Amendment L17 Belfast Planning Scheme.

The Amendment comes into operation on the date this notice is published in the Government Gazette.

The amendment to substitutes the parcel of land to be transferred to the Crown as part of the subdivision allowed under Clause 6D.1 in Chapter 1: Tower Hill of the Belfast Planning Scheme. The Amendment also extends the time limit for this provision within the Scheme from 21 August 1999 to 21 August 2005.

A copy of the Amendment can be inspected, free of charge, during office hours, at the Department of Infrastructure, Customer Service Centre, Upper Plaza, Nauru House, 80 Collins Street, Melbourne and at the offices of the Moyne Shire Council, Port Fairy Office, Princes Street, Port Fairy.

LEIGH PHILLIPS
Director, Planning Operations
Planning, Heritage and
Market Information Division
Department of Infrastructure

The Amendment comes into operation on the date this notice is published in the Government Gazette.

The amendment affects the area known as the Reid Estate and Environs, within (but not including all of) the block bounded by Whitehorse Road, Knutsford Street, Mont Albert Road and Campbell Road, Deepdene by modifying the area affected by the Heritage Overlay. The amendment deletes the Heritage Overlay from applying to land owned by Camberwell Grammar, at the southern end of Walsh Street, Deepdene and on the eastern side of the road, as well as land known as 10 Barnsbury Road, Deepdene.

A copy of the Amendment can be inspected, free of charge, during office hours, at the Department of Infrastructure, Customer Service Centre, Upper Plaza, Nauru House, 80 Collins Street, Melbourne and at the offices of the Boroondara City Council, 8 Inglesby Road, Camberwell.

LEIGH PHILLIPS
Director, Planning Operations
Planning, Heritage and
Market Information Division
Department of Infrastructure

Planning and Environment Act 1987

KINGSTON PLANNING SCHEME
Notice of Approval of Amendment

Amendment L 51

The Minister for Planning and Local Government has approved Amendment L51 Kingston Planning Scheme.

The Amendment comes into operation on the date this notice is published in the Government Gazette.

Planning and Environment Act 1987

BOROONDARA PLANNING SCHEME
Notice of Approval of Amendment

Amendment L 42

The Minister for Planning and Local Government has approved Amendment L42 Boroondara Planning Scheme.

The amendment changes Clause 155 of the Local Section of the Kingston Planning Scheme, and the Schedule of Incorporated Documents, by inserting the "Kingston Lodge Concept Plan Date 2/12/97" and the "Kingston Lodge Precinct Development Plan Date 2/12/97" to formally include these documents as originally intended by Amendment L 33 to the Kingston Planning Scheme approved on 19 February 1999.

A copy of the Amendment can be inspected, free of charge, during office hours, at the Department of Infrastructure, Customer Service Centre, Upper Plaza, Nauru House, 80 Collins Street, Melbourne and at the offices of the Kingston City Council, Mentone Offices, corner Mentone Parade & Brindisi Street, Mentone and Moorabbin Offices, 999 Nepean Highway, Moorabbin.

LEIGH PHILLIPS
Director, Planning Operations
Planning, Heritage and
Market Information Division
Department of Infrastructure

Planning and Environment Act 1987

NILLUMBIK PLANNING SCHEME

Notice of Approval of Amendment

Amendment L 25

The Minister for Planning and Local Government has approved Amendment L25 Nillumbik Planning Scheme.

The Amendment comes into operation on the date this notice is published in the Government Gazette.

The amendment rezones land at Crown Allotment 3A, Township of Panton Hill, Parish of Greensborough from Public Purposes 11 Reservation (Ministry of Education – other than schools) to a Township Zone under Section 20(4) of the *Planning and Environment Act 1987*.

A copy of the Amendment can be inspected, free of charge, during office hours, at the Department of Infrastructure, Customer Service Centre, Upper Plaza, Nauru House, 80 Collins Street, Melbourne and at the offices of the Nillumbik Shire Council, Civic Drive, Greensborough.

LEIGH PHILLIPS
Director, Planning Operations
Planning, Heritage and
Market Information Division
Department of Infrastructure

Planning and Environment Act 1987

YARRA RANGES PLANNING SCHEME

Notice of Approval of Amendment

Amendment L 108

The Minister for Planning and Local Government has approved Amendment L108 to the Yarra Ranges Planning Scheme.

The Amendment comes into operation on the date this notice is published in the Government Gazette.

The amendment includes a site specific provision allowing soil removal at Lots 6 and 7 PS 307794, Little Yarra Rd, Three Bridges subject to the grant of a permit by Council. The land is contaminated by dieldrin.

A copy of the Amendment can be inspected, free of charge, during office hours, at the Department of Infrastructure, Customer Service Centre, Upper Plaza, Nauru House, 80 Collins Street, Melbourne and at the offices of the Yarra Ranges Shire Council, Anderson St, Lilydale.

LEIGH PHILLIPS
Director, Planning Operations
Planning, Heritage and
Market Information Division
Department of Infrastructure

ORDERS IN COUNCIL

Land Act 1958

APPROVAL BY THE GOVERNOR IN
COUNCIL TO THE SALE OF CROWN
LAND BY PRIVATE TREATY

Order in Council

The Governor in Council, pursuant to section 99A(1)(a) & 99A(2) of the **Land Act 1958**, approves the sale by private treaty of Crown Allotment 23^A, Section C, Parish of Benalla located at Faithful Street, Benalla.

Dated 17 August 1999.

Responsible Minister:
ROGER M. HALLAM, MLC
Minister for Finance

SHANNON DELLAMARTA
Acting Clerk of the Executive Council

Land Act 1958

APPROVAL BY THE GOVERNOR IN
COUNCIL TO THE SALE OF CROWN
LAND BY PRIVATE TREATY

Order in Council

The Governor in Council, pursuant to section 99A(1)(a) & 99A(2) of the **Land Act 1958**, approves the sale by private treaty of Crown land described below.

Property Address: Tobin Street, Stony Creek.

Crown Description: Allotment 1, Section E, Township of Stony Creek.

Dated 17 August 1999.

Responsible Minister:
ROGER M. HALLAM, MLC
Minister for Finance

SHANNON DELLAMARTA
Acting Clerk of the Executive Council

Land Act 1958

APPROVAL BY THE GOVERNOR IN
COUNCIL TO THE SALE OF CROWN
LAND BY PRIVATE TREATY

Order in Council

The Governor in Council, pursuant to section 99A(1)(a) & 99A(2) of the **Land Act 1958**, approves the sale by private treaty of Crown land described below.

Property Address: Coal Creek Road, Korumburra.

Crown Description: Allotment 10A, Section R, Township of Korumburra.

Dated 17 August 1999.

Responsible Minister:
ROGER M. HALLAM, MLC
Minister for Finance

SHANNON DELLAMARTA
Acting Clerk of the Executive Council

Magistrates' Court Act 1989

ORDER REVOKING APPOINTMENT AS A
JUSTICE OF PEACE

Under the powers found in section 116 (a) of the **Magistrates' Court Act 1989** the Governor in Council revokes the appointment of Mr William Thomas Hickey as a Justice of Peace.

Dated 10 August 1999.

Responsible Minister:
JAN WADE, MP
Attorney-General

SHANNON DELLAMARTA
Acting Clerk of the Executive Council

Crown Land (Reserves) Act 1978

NOTICE OF INTENTION TO REVOKE THE
FOLLOWING TEMPORARY
RESERVATIONS

The Governor in Council under Section 10 of the **Crown Land (Reserves) Act 1978**, gives notice of intention to revoke the following temporary reservations:

KYNETON — The temporary reservation by Order in Council of 30 November, 1982 of an area of 2518 square metres of land being Crown Allotment 33, Section 50, Township of Kyneton, Parish of Lauriston as a site for a Public Park. — (Rs 2080).

KYNETON — The temporary reservation by Order in Council of 24 March, 1885 of an area of 4.047 hectares, more or less, of land in Section 50, Township of Kyneton, Parish of Lauriston as a site for a Public Park, revoked as to part by Order in Council of 29 July, 1969 so far only as the portion containing 2.8 hectares, more or less, as indicated by hatching on plan hereunder. (K96[2]) — (Rs 2080).

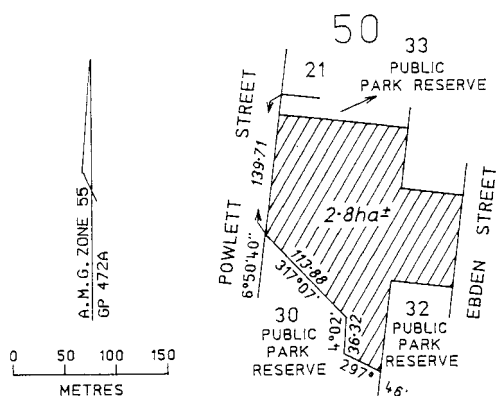

KYNETON — The temporary reservation by Order in Council of 28 October, 1980 of an area of 1 hectare, more or less, of land being Crown Allotment 14, Section H, and Crown Allotment 32, Section 50, Township of Kyneton, Parish of Lauriston as a site for a Public Park, so far only as the portion containing 5550 square metres, more or less, as indicated by hatching on plan hereunder. (K96[2]) — (Rs 2080).

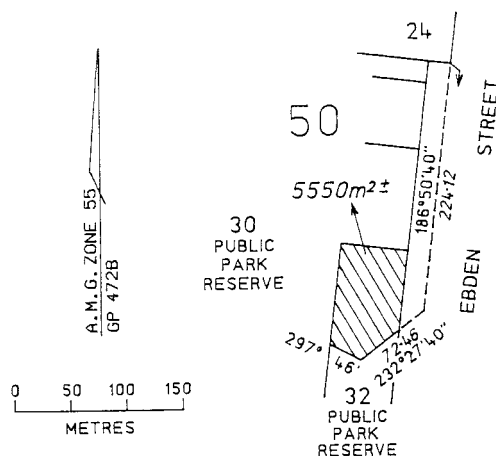

LISMORE — The temporary reservation by Order in Council of 10 July, 1945 of an area of 3389 square metres of land in Section 18, Township of Lismore, Parish of Lismore as a site for Police purposes, revoked as to part by Orders in Council of 29 March, 1966 and 9 May, 1995 so far as the balance remaining containing 2073 square metres. — (Rs 5679).

NILLUMBIK — The temporary reservation by Order in Council of 21 February, 1881 of an area of 4047 square metres of land in Section 2, Parish of Nillumbik as a site for a Quarry. — (Rs 37052).

PATCHEWOLLOCK — The temporary reservation by Order in Council of 18 August, 1924 of an area of 2.423 hectares of land in the Parish of Patchewollock as a site for a Cemetery. — (Rs 2974).

SCARSDALE — The temporary reservation by Order in Council of 26 February, 1872 of an area of 8.094 hectares of land in Section 22, Parish of Scarsdale as a site for Recreation Ground and Mustering Paddock, revoked as to part by Order in Council of 20 August, 1934 so far as the balance remaining containing 6.809 hectares. — (Rs 1001).

This Order is effective from the date on which it is published in the Government Gazette.

Dated 17 August 1999.

Responsible Minister:

MARIE TEHAN

Minister for Conservation and Land Management

SHANNON DELLAMARTA

Acting Clerk of the Executive Council

Crown Land (Reserves) Act 1978

NOTICE OF INTENTION TO REVOKE TEMPORARY RESERVATION

The Governor in Council under Section 10 of the **Crown Land (Reserves) Act 1978** gives notice of intention to revoke the following temporary reservations:

CARLTON — The temporary reservation by Order in Council of 26 January, 1916 of an area of 8309 square metres of land being Crown Allotment 2, Section 39A, At Carlton, Parish of Jika Jika (formerly City of Melbourne, At Carlton) as a site for a Training College for Teachers, in addition to and adjoining the site temporarily reserved therefor by Order in Council of 5 September, 1887 — (Rs 1035).

This Order is effective from the date on which it is published in the Government Gazette.

Dated 17 August 1999.

Responsible Minister:

MARIE TEHAN

Minister for Conservation and Land Management

SHANNON DELLAMARTA

Acting Clerk of the Executive Council

Crown Land (Reserves) Act 1978
REVOCATION OF TEMPORARY
RESERVATION

The Governor in Council under Section 10 of the **Crown Land (Reserves) Act 1978** revokes the following temporary reservation:

WORTONGIE — The temporary reservation by Order in Council of 26 January, 1921 of an area of 8094 square metres of land in the Parish of Wortongie as a site for a State School. — (Rs 2257).

This Order is effective from the date on which it is published in the Government Gazette.

Dated 17 August 1999.

Responsible Minister:
MARIE TEHAN
Minister for Conservation and Land
Management

SHANNON DELLAMARTA
Acting Clerk of the Executive Council

Crown Land (Reserves) Act 1978
REVOCATION OF TEMPORARY
RESERVATION

The Governor in Council under Section 10 of the **Crown Land (Reserves) Act 1978** revokes the following temporary reservation:

SCARSDALE — The temporary reservation by Order in Council of 29 November, 1977 of an area of 10.62 hectares of land being Crown Allotment 13, Section 28, Parish of Scarsdale as a site for Public Purposes (Supply of Gravel). — (Rs 1173).

This Order is effective from the date on which it is published in the Government Gazette.

Dated 17 August 1999.

Responsible Minister:
MARIE TEHAN
Minister for Conservation and Land
Management

SHANNON DELLAMARTA
Acting Clerk of the Executive Council

Crown Land (Reserves) Act 1978
TEMPORARY RESERVATION OF CROWN
LAND

The Governor in Council under Section 4(1) of the **Crown Land (Reserves) Act 1978**

temporarily reserves the following Crown land which in his opinion is required for the purpose mentioned:-

MUNICIPAL DISTRICT OF
THE MONASH CITY COUNCIL

MULGRAVE — Public Recreation, 1.813 hectares, shown as Lot 2 on Plan of Subdivision No. 401886S lodged in the Office of Titles and being Crown Allotment 110C, Parish of Mulgrave. — (Rs 37219).

This Order is effective from the date on which it is published in the Government Gazette.

Dated 17 August 1999.

Responsible Minister:
MARIE TEHAN
Minister for Conservation and Land
Management

SHANNON DELLAMARTA
Acting Clerk of the Executive Council

Crown Land (Reserves) Act 1978
PERMANENT RESERVATION OF
CROWN LAND

The Governor in Council under Section 4(1) of the **Crown Land (Reserves) Act 1978** permanently reserves the following Crown land which in his opinion is required for the purpose mentioned:-

MUNICIPAL DISTRICT OF
THE DAREBIN CITY COUNCIL

JIKA JIKA — Public Park and Memorial Gardens, 2.202 hectares, being Crown Allotment 133J, Parish of Jika Jika as shown on Certified Plan No. 119278 lodged in the Central Plan Office. — (Rs 37220).

This Order is effective from the date on which it is published in the Government Gazette.

Dated 17 August 1999.

Responsible Minister:
MARIE TEHAN
Minister for Conservation and Land
Management

SHANNON DELLAMARTA
Acting Clerk of the Executive Council

Land Act 1958

CLOSURE OF UNUSED ROADS

The Governor in Council under Section 349 of the **Land Act 1958** and with the concurrence in writing of the municipalities in which the roads are situated and the owners of land adjoining those roads closes the following unused roads:

MUNICIPAL DISTRICT OF THE SOUTH GIPPSLAND SHIRE COUNCIL

JEETHO WEST — The road in the Parish of Jeetho West as indicated by hatching on plan hereunder. (2788) — (14/P28215).

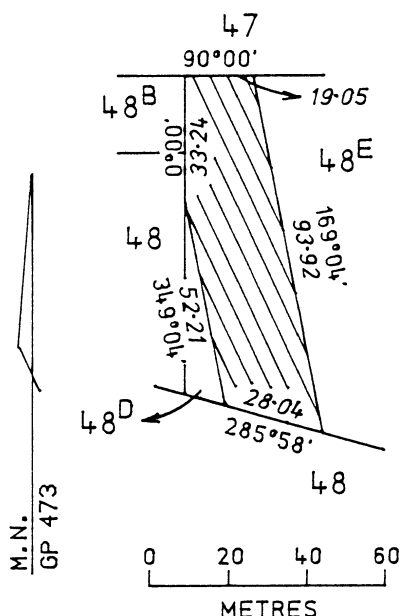

MUNICIPAL DISTRICT OF THE STATHBOGIE SHIRE COUNCIL

WORMANGAL — The road in the Parish of Wormangal shown as Crown Allotment 30C on Certified Plan No. 119830 lodged in the Central Plan Office. — (08/L7-5288).

This Order is effective from the date on which it is published in the Government Gazette.

Dated 17 August 1999.

Responsible Minister:
MARIE TEHAN
 Minister for Conservation and Land Management

SHANNON DELLAMARTA
 Acting Clerk of the Executive Council

Crown Land (Reserves) Act 1978

INCORPORATION OF COMMITTEE OF MANAGEMENT OF THE EVANSFORD COMMUNITY CENTRE RESERVE

The Governor in Council under Section 14A(1) of the **Crown Land (Reserves) Act 1978**, being satisfied that it is in the public interest to declare to be a corporation the Committee of Management appointed under section 14(2) of the Act of the land described in the schedule hereunder:-

- (a) declares that the Committee of Management shall be a corporation;
- (b) assigns the name "EVANSFORD COMMUNITY CENTRE COMMITTEE OF MANAGEMENT INCORPORATED" to the corporation; and

under section 14B(3) of the Act, appoints Mary-Ann OGLE-JOYCE to be Chairperson of the corporation

SCHEDULE

The land in the Township of Evansford, Parish of Caralulup being Crown Allotment 81A, temporarily reserved as a site for a Public Hall by Order in Council of 25 March, 1986 published in the Government Gazette on 2 April, 1986 - page 830. — (Rs 12942).

This Order is effective from the date on which it is published in the Government Gazette.

Dated 17 August 1999.

Responsible Minister:
MARIE TEHAN
 Minister for Conservation and Land Management

SHANNON DELLAMARTA
 Acting Clerk of the Executive Council

Crown Land (Reserves) Act 1978

INCORPORATION OF COMMITTEE OF MANAGEMENT OF THE STONEY CREEK HALL RESERVE

The Governor in Council under Section 14A(1) of the **Crown Land (Reserves) Act 1978**, being satisfied that it is in the public interest to declare to be a corporation the Committee of Management appointed under section 14(2) of the Act of the land described in the schedule hereunder:-

- (a) declares that the Committee of Management shall be a corporation;
- (b) assigns the name "STONEY CREEK HALL COMMITTEE OF MANAGEMENT INCORPORATED" to the corporation; and under section 14B(3) of the Act, appoints Frank HELMS to be Chairperson of the corporation

SCHEDULE

The land in the Township of Stoney Creek, (formerly Township of Dumbalk), being Crown Allotment 9, Section F, temporarily reserved as a site for a Mechanics' Institute Hall by Order in Council of 26 September, 1893 published in the Government Gazette on 29 September, 1893 - page 3958 — (Rs 4549).

This Order is effective from the date on which it is published in the Government Gazette.

Dated 17 August 1999.

Responsible Minister:

MARIE TEHAN

Minister for Conservation and Land Management

SHANNON DELLAMARTA

Acting Clerk of the Executive Council

Crown Land (Reserves) Act 1978

INCORPORATION OF COMMITTEE OF MANAGEMENT OF THE NOWA NOWA RECREATION RESERVE

The Governor in Council under Section 14A(1) of the **Crown Land (Reserves) Act 1978**, being satisfied that it is in the public interest to declare to be a corporation the Committee of Management appointed under section 14(2) of the Act of the land described in the schedule hereunder:-

- (a) declares that the Committee of Management shall be a corporation;
- (b) assigns the name "NOWA NOWA RECREATION RESERVE COMMITTEE OF MANAGEMENT INCORPORATED" to the corporation; and

under section 14B(3) of the Act, appoints Brian BLAKEMAN to be Chairperson of the corporation

SCHEDULE

- 1. The land in the Township of Nowa Nowa temporarily reserved as a site for Public

Recreation by Order in Council of 24 August, 1891 and published in the Government Gazette on 28 August, 1891 - page 3725, (Rs 2286);

- 2. The lands in the Township of Nowa Nowa and the Parish of Tildesley West temporarily reserved as a site for Public purposes (Tourists' Camp) by Order in Council of 13 May, 1941 and published in the Government Gazette on 14 May, 1941 - page 1904 together with that portion of the permanent reserve along Bogy Creek as coloured blue on Plan No. T/14-3-1942 attached to Department of Natural Resources and Environment file No. Rs 5196, (Rs 5196);
- 3. The land in the Township of Nowa Nowa temporarily reserved as a site for Public Recreation by Order in Council of 24 January, 1967 and published in the Government Gazette on 1 February, 1967 - page 265, (Rs 2286);
- 4. The land in the Township of Nowa Nowa temporarily reserved as a site for Public Recreation by Order in Council of 27 May, 1987 and published in the Government Gazette on 3 June, 1987 - page 1070, (Rs 2286); and
- 5. The land in the Township of Nowa Nowa as shown coloured pink on Plan No. NN/28-01-99 attached to Department of Natural Resources and Environment file No. 2286 being part of the area permanently reserved for Public Purposes by Order in Council of 23 May, 1881, (Rs 2298).

This Order is effective from the date on which it is published in the Government Gazette.

Dated 17 August 1999.

Responsible Minister:

MARIE TEHAN

Minister for Conservation and Land Management

SHANNON DELLAMARTA

Acting Clerk of the Executive Council

**SUBORDINATE LEGISLATION ACT 1994
NOTICE OF MAKING OF STATUTORY
RULES**

Notice is hereby given under Section 17 (2) of the **Subordinate Legislation Act 1994** of the making of the following Statutory Rules:

103. *Statutory Rule:* Fair Trading Regulations 1999
Authorising Act: Fair Trading Act 1999
Date of making: 17 August 1999
104. *Statutory Rule:* Motor Car Traders (Prescribed Forms) Regulations 1999
Authorising Act: Motor Car Traders Act 1986
Date of making: 17 August 1999
105. *Statutory Rule:* Credit (Administration) (Prescribed Forms) Regulations 1999
Authorising Act: Credit (Administration) Act 1984
Date of making: 17 August 1999
106. *Statutory Rule:* Travel Agents (Prescribed Forms) Regulations 1999
Authorising Act: Travel Agents Act 1986
Date of making: 17 August 1999
107. *Statutory Rule:* Drugs, Poisons and Controlled Substances (Drugs of Dependence) Regulations 1999
Authorising Act: Drugs, Poisons and Controlled Substances Act 1981
Date of making: 17 August 1999
108. *Statutory Rule:* Health (Infectious Diseases) (Donation Statement) Regulations 1999
Authorising Act: Health Act 1958
Date of making: 17 August 1999

**SUBORDINATE LEGISLATION ACT 1994
NOTICE THAT STATUTORY RULES ARE
OBTAINABLE**

Notice is hereby given under Section 17 (3) of the **Subordinate Legislation Act 1994** that the following Statutory Rules were first obtainable from Information Victoria, 356 Collins Street, Melbourne on the date specified:

101. *Statutory Rule:* Police (Amendment) Regulations 1999
Authorising Act: Police Regulation Act 1958
Date first obtainable: 19 August 1999
Code A
102. *Statutory Rule:* Firearms (Amendment) Regulations 1999
Authorising Act: Firearms Act 1996
Date first obtainable: 19 August 1999
Code A

Retail price will vary according to the number of pages in each special or periodical gazette. The table below sets out the prices that apply

<i>Price Code</i>	<i>No. of Pages (Including cover and blank pages)</i>	<i>Price</i>
A	1-16	\$2.90
B	17-32	\$4.30
C	33-48	\$5.90
D	49-96	\$9.15
E	97-144	\$11.85
F	145-192	\$14.00
G	193-240	\$16.15
H	241-288	\$17.20
I	289-352	\$19.35
J	353-416	\$22.60
K	417-480	\$25.80
L	481-544	\$30.10
M	545-608	\$34.40
N	609-672	\$38.70
O	673-736	\$43.00
P	737-800	\$47.30

ADVERTISERS PLEASE NOTE

As from 19 August 1999

The last Special Gazette was No. 125 dated 18 August 1999

The last Periodical Gazette was No. 1 dated 25 May 1999

CONTENTS

	Page
Estates of Deceased Persons	1895
Government and Outer Budget Sector	
Agencies Notices	1903
Orders in Council—	1921
Acts — Control of Weapons; Vocational Education and Training	
Private Advertisements	1895
Proclamations	1901

The Victoria Government Gazette is published by The Craftsman Press Pty. Ltd. with the authority of the Government Printer for the State of Victoria
© State of Victoria 1999

ISSN 0819-5471

This publication is copyright. No parts may be reproduced by any process except in accordance with the provisions of the Copyright Act.

Products and services advertised in this publication are not endorsed by The Craftsman Press Pty. Ltd. or the State of Victoria and neither of them accepts any responsibility for the content or the quality of reproduction. The Craftsman Press Pty. Ltd. reserves the right to reject any advertising material it considers unsuitable for government publication.

Address all enquiries to the Government Printer for the State of Victoria
Government Information and Communications Branch
Department of Premier and Cabinet
Level 3, 356 Collins Street
Melbourne 3000
Victoria Australia

RETAIL SALES

Information Victoria Bookshop
356 Collins Street Melbourne 3000.
Telephone enquiries 1300 366 356

City Graphics
2nd Floor, 4 Bank Place
Melbourne 3000
Telephone enquiries (03) 9600 0977

Recommended Retail Price \$1.70

Government and Outer Budget Sector Agencies please note:
STYLE REQUIREMENTS.

To ensure that material received can be reproduced, and that errors are minimised, the following guidelines are to be observed when submitting material by fax.

Fax resolution:

Material sent by fax should be transmitted using Fine Resolution (200 dots per inch by 200 dpi).

Font size:

Use 12 point (10 pitch) or larger.

Font Style:

Clear plain font styles, such as Helvetica, should be used.

Graphics:

Line drawings should be transmitted as large as possible to ensure clarity. Drawings up to A4 size sent by fax using Fine Resolution provide a good quality for reproduction.

Avoid:

Italics, underlining and full justification.

Ensure document is square when sending as documents that are sent skewed are difficult to read and process.