



Victoria Government Gazette

No. G 10 Thursday 9 March 2000

GENERAL

GENERAL AND PERIODICAL GAZETTE

Copy to: Gazette Officer
The Craftsman Press Pty. Ltd.
125 Highbury Road,
Burwood Vic 3125
Telephone: (03) 9926 1233
Facsimile: (03) 9926 1292
DX: 32510 Burwood
Email: gazette@craftpress.com.au

Advertising Rates and Payment

Private Notices

Payment must be received in advance with advertisement details.

30 cents per word - Full page \$180.00.

Additional costs must be included in prepayment if a copy of the gazette is required. Copy Prices - Page

\$1.50 - Gazette \$3.20 Certified copy of Gazette \$3.50. (all prices include Postage). **Cheques should be made payable to The Craftsman Press Pty. Ltd.**

Government and Outer Budget Sector Agencies Notices

Not required to pre-pay.

Advertisements may be faxed or sent via email with a cover sheet, marked to the attention of the Gazette Officer.

Floppy Disks (Mac & PC) can also be accepted.

Costs can be calculated on the following basis:

Per Line	Typeset
Single column	\$1.55
Double column	\$3.10
Full Page	\$64.80

The Craftsman Press is pleased to offer a series of discounts from the typesetting costs.

1. Copy supplied on disk.
2. Copy supplied via email.
3. Artwork for forms and other material which require exact reproduction.

1. Copy supplied on disk.

Where a disk is supplied and there is minimum alteration required, **30% off.**

Where a disk is supplied requiring extraneous matter stripped out and styles applied, **20% off.**

2. Copy supplied via email.

Where a notice is sent via email and there is minimum alteration required, **25% off.**

Where email is supplied requiring extraneous matter stripped out and styles applied, **15% off.**

3. Artwork for forms and other material which requires exact reproduction.

Scanning and sizing of artwork for forms, to be reproduced in page format, **35% off.**

Copy Deadline for General Gazette

9.30 a.m. Monday - (Private Notices)

9.30 a.m. Tuesday - (Government and Outer Budget Sector Agencies Notices)

Advertisers should note:

- Late copy received at The Craftsman Press Pty. Ltd. after deadlines will be placed in the following issue of VGG, irrespective of any date/s mentioned in the copy (unless otherwise advised).
- Proofs will be supplied only when requested or at the direction of the Gazette Officer.
- No additions or amendments to material for publications will be accepted by telephone.
- Orders in Council may be lodged prior to receiving assent with the Governor's or Clerk's signature. They will only be published once approved and signed.
- Government and Outer Budget Sector Agencies please note: *See style requirements on back page.*

SPECIAL GAZETTES

Copy to: Gazette Officer
The Craftsman Press Pty. Ltd.
125 Highbury Road,
Burwood Vic 3125
Telephone: (03) 9926 1233
Facsimile: (03) 9926 1292
Email: gazette@craftpress.com.au

Advertising Rates and Payment

Private Notices

Full Page \$360.00

Payment must be received in advance with notice details.

Government and Outer Budget Sector Agencies Notices

	Typeset
Full Page	\$87.50

Note:

The after hours number for Special Gazettes is:
Telephone: 0419 327 321

SUBSCRIPTIONS AND RETAIL SALES

Copies of the Victoria Government Gazette can be purchased from The Craftsman Press Pty. Ltd. by subscription.

The Victoria Government Gazette

General and Special - \$170.00 each year

General, Special and Periodical - \$227.00 each year

Periodical - \$113.00 each year

Subscriptions are payable in advance and accepted for a period of one year. All subscriptions are on a firm basis and refunds will not be given.

All payments should be made payable to The Craftsman Press Pty. Ltd.

Subscription enquiries:

The Craftsman Press Pty. Ltd.
125 Highbury Road, Burwood Vic 3125
Telephone: (03) 9926 1233

INDEX TO PRIVATE ADVERTISERS

A	H
Adams & Garde416	Hassall & Byrne418
Aitken Walker & Strachan416	
AXA Trustees Limited416	J
	James Higgins & Co.418
B	
Borchard & Moore416	
Bullards417	L
	Littleton Hackford418
C	
Chambers & Company417	M
	Mitchell, McKenzie & Co.419
D	
De Marco & Co.417	P
	Perpetual Trustees Victoria Limited419
E	
Equity Trustees Limited418	R
	Rigby Cooke419
F	Russell Kennedy419
F. McGrath & Co.418	Russo Pellicano Carlei419
G	S
Geoff Dillon & Co.418	Sam Stidson & Co.419
Grano & McCarthy418	
Gullaci & Gullaci418	

**PUBLICATION OF THE
VICTORIA GOVERNMENT
GAZETTE (GENERAL)
LABOUR DAY - PUBLIC
HOLIDAY**

PLEASE NOTE:

The Victoria Government Gazette for Labour Day week will be published on Thursday, 16 March 2000. All copy for Private advertisements must reach the Government Gazette Office by no later than 9.30 a.m. on Friday, 10 March 2000. The deadline for advertisements for the Government and Outer Budget Sector Agencies remains unchanged, ie: Tuesday, 14 March 2000.

Where urgent gazettal is required after hours, arrangements should be made with Ann White on 0419 327321.

ANN WHITE

Government Gazette Officer

PRIVATE ADVERTISEMENTS

DISSOLUTION OF PARTNERSHIP

Notice is hereby given that the partnership between Comtek Computers Pty Ltd, A.C.N. 076 573 343 and Grasshopper Internet Pty Ltd, A.C.N. 086 385 962, carrying on business as "Iceblue" at 22 Eastmead Road, Croydon, Victoria, was dissolved on 25 February 2000.

Dated 28 February 2000.

THE COMMON SEAL OF COMTEK)
 COMPUTERS PTY LTD was affixed to)
 this Deed in accordance with its)
 Constitution in the presence of:)

DANIEL HOBSON
 in his capacity as Sole Director and
 Sole Secretary of the Company

THE COMMON SEAL OF)
 GRASSHOPPER INTERNET PTY LTD)
 was affixed to this Deed in accordance)
 with its Constitution in the presence of:)

CAMERON WATSON
 in his capacity as Sole Director and
 Sole Secretary of the Company

Creditors, next-of-kin and others having claims in respect of the estate of DONALD KINGSLEY BEECROFT, late of Southern Cross Hostel, 74 Victoria Street, Hastings, Victoria, retired farmer, deceased, who died on 25 November 1999, are to send particulars of their claims to the executor, care of the undermentioned solicitors by 19 May 2000 after which date the executor will distribute the assets having regard only to the claims of which the executor then has notice.

ADAMS & GARDE, solicitors,
 P.O. Box 2107, Moorabin, Vic. 3189.

GEOFFREY ERNEST SARGANT, late of 39 Chamberlain Drive, Leongatha, retired accountant. Creditors, next-of-kin and others having claims in respect of the estate of the deceased, who died on 14 November 1999, are required by AXA Trustees Ltd, (formerly National Mutual Trustees Limited) and Christopher Geoffrey Sargant, care of 65 Southbank Boulevard, Southbank, Victoria 3006, the applicants for a grant of probate, to send particulars to them by 10 May 2000 after

which date the applicants for a grant of probate may convey or distribute the assets having regard only to the claims of which they then have notice.

CECIL JAMES BOAG, late of 13/2 Stenhouse Avenue, Brooklyn, retired, deceased. Creditors, next-of-kin and others having claims in respect of the estate of the deceased, who died on 21 October 1999, are required by the personal representatives, Christine Robertson of 14 Bruce Crescent, Ferntree Gully and Joyce Boag of 52 Teague Street, Niddrie, to send particulars to them care of the undermentioned solicitors by 17 May 2000 after which date the personal representatives may convey or distribute the assets having regard only to the claims of which they then have notice.

AITKEN WALKER & STRACHAN, solicitors,
 114 William Street, Melbourne 3000.

GORDON GRAHAM CALDER MCKENZIE, late of 27 Talbot Avenue, Balwyn, surgeon, deceased. Creditors, next-of-kin and others having claims in respect of the estate of the deceased, who died on 31 October 1999, are required by the personal representatives, Edith Pryor McKenzie of 27 Talbot Avenue, Balwyn and Fay Calder Donlevy of 65 Lang Street, South Yarra, to send particulars to them care of the undermentioned solicitors by 24 May 2000 after which date the personal representatives may convey or distribute the assets having regard only to the claims of which they then have notice.

AITKEN WALKER & STRACHAN, solicitors,
 114 William Street, Melbourne 3000.

Creditors, next-of-kin and others having claims in respect of the estate of VIOLET MAY ELIZA SPENCER, formerly of 38 Walton Street, Rhyll, Victoria, but late of Alchera House, Gordon Street, Korumburra, Victoria, pensioner, deceased, who died on 4 December 1999, are required to send particulars of their claims to the executrix care of the undermentioned solicitors by 9 May 2000 after which date the executrix will distribute the

assets having regard only to the claims for which notice has been received.

BORCHARD & MOORE, solicitors,
44 Douglas Street, Noble Park.

Creditors, next-of-kin and others having claims in respect of the estate of SUSANNA STANFORD McLEAN, late of Unit 9, 14 Chandler Road, Noble Park, Victoria, home duties, deceased, who died on 22 December 1999, are required to send particulars of their claims to the executor care of the undermentioned solicitors by 9 May 2000 after which date the executor will distribute the assets having regard only to the claims for which notice has been received.

BORCHARD & MOORE, solicitors,
44 Douglas Street, Noble Park.

Creditors, next-of-kin and others having claims in respect of the estate of NICKALY MOROZOFF, late of 25 Southbourne Avenue, Dandenong, Victoria, retired plasterer, deceased, who died on 5 November 1999, are required to send particulars of their claims to the administrator care of the undermentioned solicitors by 10 May 2000 after which date the administrator will distribute the assets having regard only to the claims for which notice has been received.

BORCHARD & MOORE, solicitors,
44 Douglas Street, Noble Park.

Creditors, next-of-kin and others having claims in respect of the estate of JANE CHUTER, late of 37 Janine Road, Springvale South, Victoria, widow, deceased, who died on 20 December 1999, are required to send particulars of their claims to the executors care of the undermentioned solicitors by 9 May 2000 after which date the executors will distribute the assets having regard only to the claims for which notice has been received.

BORCHARD & MOORE, solicitors,
44 Douglas Street, Noble Park.

EVELYN MYRTLE BLACKMAN, late of Lovell House, 389 Alma Road, Caulfield North, in the State of Victoria, widow, deceased. Creditors, next-of-kin and others having claims

in respect of the estate of the deceased, who died on 3 December 1999, are required by the trustee, David Ernest Bullard of 221 Queen Street, Melbourne, in the State of Victoria, to send particulars of their claims to him at the office of the undernamed solicitors by 11 May 2000 after which date the trustees may convey or distribute the assets, having regard only to the claims of which they then have notice.

BULLARDS, solicitors for the trustees,
221 Queen Street, Melbourne.

Estate Sir RUSSEL TULLIE MADIGAN, Kt, OBE, late of 99 Spring Street, Melbourne, Victoria, mining engineer and company director, deceased. Creditors, next-of-kin and others having claims in respect of the estate of the deceased, who died on 19 July 1999, are required by the personal representatives of the estate, Robin Hamilton Chambers of Level 43, ANZ Tower, 55 Collins Street, Melbourne, Victoria, lawyer and Aubrey Cherry of 32 Cobden Street, Kew, Victoria, chartered accountant, to send particulars to their care of Chambers & Company, Level 43, ANZ Tower, 55 Collins Street, Melbourne, Victoria, by 17 May 2000 after which date the personal representatives may convey or distribute the assets having regard only to the claims of which they then have notice.

Dated 9 March 2000.

CHAMBERS & COMPANY, lawyers,
Level 43, ANZ Tower,
55 Collins Street, Melbourne 3000.

DOROTHEA JOY ELIZABETH SHEDDICK, late of 10 Melbourne Avenue, Glenroy, Victoria, pensioner, deceased. Creditors, next-of-kin and others having claims in respect of the estate of the deceased, who died on 24 December 1999, are required by the trustee, Kathleen Alanna Keown of 695 Mickleham Road, Greenvale, Victoria, home duties, daughter, to send particulars to the trustee by 2 May 2000 after which date the trustee may convey or distribute the assets having regard only to the claims of which the trustee has notice.

DE MARCO & CO., solicitors,
209 Glenroy Road, Glenroy 3046.

Creditors, next-of-kin and others having claims in respect of the estate of OLIVE EDITH FRANCEYS LITTLETON, late of 27 Wattle Road, Hawthorn, home duties, deceased, who died on 3 November 1999, are to send particulars of their claims to Equity Trustees Limited, A.C.N. 004 031 298 of 472 Bourke Street, Melbourne, by 10 May 2000 after which date it will distribute the assets having regard only to the claims of which it then has notice.

Creditors, next-of-kin and others having claims in respect of the estate of WILLIAM JOHN ROY TAIT, also known as John William Tait, late of 44 Charles Street, Dromana, in the State of Victoria, retired, deceased, who died on 15 October 1999, are required to send particulars thereof to Francis McGrath, the executor of the will of the said deceased, care of the undermentioned solicitors within two months of the date of this notice after which date the executor will distribute the assets to the persons entitled having regard only to the claims of which they then have notice.

F. McGRATH & CO., solicitors,
16 Beach Street, Dromana 3936.

Creditors, next-of-kin and others having claims in respect of the estate of CLIFFORD JOHN EVERETT PICKETT, deceased, late of 21 Upper Heidelberg Road, Ivanhoe, in the State of Victoria, retired, gentleman, who died on 21 January 2000, are required by the executrix, Marilyn Dorothy Longworth of 11 Heysham Drive, Wheelers Hill, in the said State, to send particulars to her by 2 May 2000 after which date she may convey or distribute the estate having regard only to the claims of which she then has notice.

GEOFF DILLON & CO, commercial lawyers,
Level 9, 167 Queen Street,
Melbourne, Vic. 3000.

DOROTHY MARLINE ANNIE JENKINSON, late of 2170 Cressy Road, Shelford, home duties, deceased. Creditors, next-of-kin and others having claims in respect of the estate of the

deceased, who died on 16 November 1999, are required by Raymond Nestor Grigsby, the executor of the estate of the deceased, to send particulars of their claims to him care of the undermentioned legal practitioner by 15 May 2000, after which date he will convey or distribute the assets having regard only to the claims which he then has notice.

GRANO & McCARTHY, legal practitioners,
178 Barkly Street, Ararat.

GEORGE TABONE, late of 642 Bell Street, Coburg, in the State of Victoria, pensioner, deceased. Creditors, next-of-kin and others having claims in respect of the estate of the abovenamed deceased, who died on 10 December 1999, are required by Ferdinand John Tabone and Elda Camilleri, the executors of the said estate, to send particulars by 12 May 2000 to their solicitors, Gullaci & Gullaci of 158 Bell Street, Coburg, after which date the executors may convey or distribute the assets, having regard only to the claims of which they then have notice.

GULLACI & GULLACI, solicitors,
158 Bell Street, Coburg, Victoria 3058.

Creditors, next-of-kin and others having claims against the estate of JESSIE FRANCES McKAY, late of Elanora Home for the Blind, 7 Mair Street, Brighton, Victoria, who died on 18 August 1999, are required by the executor, Equity Trustees Limited, A.C.N. 004 031 298 of 472 Bourke Street, Melbourne to send detailed particulars of their claims to the said executor, c/- Hassall & Byrne, solicitors of 308 Highett Road, Highett 3190 by 9 May 2000 after which date it will proceed to distribute the said estate having regard only to the claims of which it then has notice.

HASSALL & BYRNE, solicitors,
308 Highett Road, Highett 3190.

ELSIE MADELINE JACK, late of 569 Glenhantly Road, Elsternwick, Victoria, widow, deceased. Creditors, next-of-kin and others having claims in respect of the estate of the deceased, who died on 28 November 1999,

are required by the executor, Equity Trustees Limited, A.C.N. 004 031 298 of 472 Bourke Street, Melbourne, Victoria, to send particulars of their claims to the executor care of James Higgins & Co., 443 Little Collins Street, Melbourne, by 10 May 2000 after which date the executor will convey or distribute the assets having regard only to the claims of which the executor then has notice.

JAMES HIGGINS & CO., solicitors & notary,
443 Little Collins Street, Melbourne.

After publication of this notice an application for probate of the will dated 9 October 1986 of JENNIE LITTLEDALE WILTSHIRE, late of Brighton but formerly of South Yarra, widow, will be made by Perpetual Trustees Victoria Limited, A.C.N. 004 027 258. Creditors are required to send particulars of their claims upon the estate to Perpetual Trustees Victoria Limited, C/- 5th Floor, 39 Hunter Street, Sydney, NSW 2000.

Creditors, next-of-kin or others having claims in respect of the estate of DONALD HENRY MALCOLM HALES, late of 2 Carlyon Close, Moama, New South Wales, pensioner, deceased, who died on 18 January 2000, are to send particulars of their claims to the executors care of the undermentioned solicitors by 23 May 2000 after which date the executors will distribute the assets having regard only to the claims of which the executors then have notice.

MITCHELL, McKENZIE & CO., solicitors,
51-55 Heygarth Street, Echuca.

Creditors, next-of-kin or others having claims in respect of the estate of EDNA MAVIS RUFFIN, late of 46 Mendip Road, Reservoir, Victoria, deceased, who died on 13 October 1999, are to send particulars of their claims to the executor care of the undermentioned solicitors by 11 May 2000 after which date the executor will distribute the assets having regard only to the claims of which the executor then has notice.

RIGBY COOKE, solicitors,
101 Collins Street, Melbourne 3000.

KATHLEEN SYLVIA SUNDFORS, late of Nirvana Nursing Home, 78 Nirvana Avenue, East Malvern, widow, deceased. Creditors, next-of-kin and others having claims in respect of the estate of the deceased, who died on 18 February 2000, are required by ANZ Executors & Trustee Company Limited, A.C.N. 006 132 332, the executor of the will of the deceased, to send particulars of their claims to the executor of Level 11, 530 Collins Street, Melbourne, by 10 May 2000, after which date the executor may convey or distribute the assets having regard only to the claims of which it then has notice.

RUSSELL KENNEDY, solicitors,
10th Floor, 469 La Trobe Street, Melbourne.

GIUSEPPE SFAMENI, late of 1532 Dandenong Road, Oakleigh, widower, deceased. Creditors, next-of-kin and others having claims in respect of the estate of the deceased, who died on 19 June 1999, are required by the trustees, Santo Sfameni of 35 Elanora Road, Vermont South, Victoria, hairdresser, son and Frank Ravidia of 6 Remington Drive, Glen Waverley, Victoria, builder, son-in-law, to send particulars to the trustees by 15 May 2000 after which date the trustees may convey or distribute the assets having regard only to the claims of which the trustees have notice.

RUSSO PELLICANO CARLEI, solicitors,
43 Atherton Road, Oakleigh 3166.

JESSIE GWEN McARTHUR, late of 15 Eric Crescent, Mornington, Victoria, retired, deceased. Creditors, next-of-kin and others having claims in respect of the estate of the deceased, who died on 1 October 1999, are required by the trustee, Elizabeth Roberts Hall of 15 Eric Crescent, Mornington, Victoria, to send particulars to her by 12 May 2000 after which date the trustee may convey or distribute the assets having regard only to the claims of which she then has notice.

SAM STIDSTON & CO., solicitors,
307 Main Street, Mornington.

Unclaimed Moneys Act 1962

Register of Unclaimed Moneys held by the —

<i>Name of Owner on Books and Last Known Address</i>	<i>Total Amount Due to Owner</i>	<i>Description Of Unclaimed Money</i>	<i>Date when Amount first became Payable</i>
OFFICE OF HOUSING			
	\$		
		Rent	
Abblitt Diane, 6/12 Queen Street, Kings Beach, Caloundra	256.20	Overpayment	17/04/97
Aley Norma, 67 Songlark Crescent, Werribee	119.10	"	04/03/97
Ansell Madge, 53 Gotha Street, Heidelberg West	116.13	"	09/11/97
Atkins Eleanor, 10/20-22 Victoria Parade, Kilmore	123.50	"	05/12/97
Batey Roslyn, 36 Stevenson Street, Wodonga	178.90	"	16/09/97
Benaissa Francois, 9/5A Munro Street, Hawthorn East	254.40	"	03/01/97
Bester Leigh, 4/41 Walker Parade, Churchill	229.70	"	20/08/97
Blake Sherlee, C/o Lismore Post Office, Lismore	189.10	"	23/02/97
Boulter Eric, 18/20 Benjamin Close, Bundoora	114.30	"	19/12/97
Bradley Esther, 79 Warmington Street, Sunshine	106.10	"	16/06/97
Bux Melissa, 206 Archer Street, Shepparton	148.00	"	25/05/97
Callander Vera, 5 Francis Street, Yea	136.00	"	30/03/97
Campbell Edith, 7 Gladstone Street, Coburg	107.70	"	16/03/97
Cann Kenneth, 948 Toorak Road, Camberwell	100.80	"	19/11/95
Carter Norman, 165/141 Nicholson Street, Carlton	113.03	"	28/09/97
Chittock Eileen, Flat 2, 64 Union Street, Ascot Vale	182.26	"	21/11/97
Clifford Shirley, 4A Nesbit Court, Castlemaine	163.80	"	14/12/97
Cooper Brian, 107 Hogans Road, Hoppers Crossing	215.00	"	23/06/97
Cooper Neville, 7/351 Barkly Street, Brunswick	127.15	"	08/06/97
Cox Anne, 303A Koornang Road, Carnegie	152.60	"	12/06/97
Czajka Mika 2/6 Ayr Street, Laverton	251.40	"	22/12/96
De Alwis Hazel 44/1 Surrey Road, South Yarra	163.30	"	25/03/97
Dinan Christine, 3 Turnberry Drive, Sunbury	174.90	"	08/06/97
Dinh Le, 152/140 Neill Street, Carlton	206.20	"	22/06/97
Donovan Mary, 1/235 Maribyrnong Road, Ascot Vale	174.70	"	21/01/98
Drinkwater Sharon, 59 Hewett Street, Charters Towers	205.44	"	20/06/93
Edmonds Percival, Cannon & Augustinus, 78 Fletcher Street, Essendon	102.90	"	22/10/95
Fisher Jessie, 6 Malta Street, West Ivanhoe	735.53	"	27/09/97
Fowkes Debra, 42 Donaldson Drive, Broadford	108.60	"	09/12/96
Garro Salvatore, 187/159 Melrose Street, North Melbourne	242.52	"	02/09/97
Ghebrial Sozan, 100/240 Wellington Street, Collingwood	209.48	"	21/09/97
Gilbert Carol, 4 Victoria Court, Dandenong North	216.40	"	24/12/97
Green Angela, 2 Orloff Street, Seymour	104.80	"	23/11/97
Hughes John, Flat 4, 41 Shepparson Avenue, Carnegie	109.00	"	08/05/97
Innes Charles, C/o State Trustees, G.P.O. Box 1461N, Melbourne	150.30	"	24/09/95
Johnson Eileen, 51/1 Holmes Street, Northcote	156.20	"	10/08/97
Jones Elizabeth, C/-Mr G. Jones, 7/217 Nepean Hwy, Seaford	176.20	"	09/02/97
Kamitsoglou Christina, 10/49 Stafford Street, Abbotsford	103.70	"	23/02/97

Kearney Robyn, 2/2 Arkana Court, Drouin	100.60	''	22/04/97
Kettle Michael, 2/2 Atami Crescent, Corio	144.70	''	09/12/96
Kingston Gloria, 7 Humphrey Street, Bairnsdale	126.36	''	18/05/97
La Ai, 8/7 Gordon Street, Footscray	150.00	''	17/04/94
Lapthorne Gladys, 23 Elm Street, North Melbourne	111.05	''	28/05/95
Le Lam, 106/140 Brunswick Street, Fitzroy	128.00	''	02/04/95
Lewis Kim, 25 Colac Street, Broadmeadows	258.75	''	22/09/97
Lontos Paraskevj, 1/1 Phillips Court, Northcote	210.35	''	12/04/97
Marsh Florence, C/-Anne Luke, 105 Dinsdale Rd, St Andrews	279.90	''	20/10/96
Marshall Betty, 1/5 Forest Drive, Frankston North	139.20	''	05/06/97
Mc Grath William, C/- Shane McGrath, Main Rd, Redesdale	270.43	''	14/07/97
McLeod Alfred, C/o Dorothy Leech, 2 Winifred St, Oak Park	175.00	''	14/04/96
Meade John, 37/6 Maryvale Crescent, Morwell	189.00	''	21/05/97
Moody Emily, Kirkbrae Hostel, Mt Dandenong Road, Kilsyth	156.13	''	19/02/95
Morshead, Joseph, 55/1 Holmes Street, Northcote	194.75	''	02/03/97
Muller Ellen, 4 Shepherd Place, Horsham	113.12	''	29/06/97
Nguyen Tam, 7/110 Victory Boulevard, Ashburton	129.90	''	12/06/97
Nicolaci Frank, 20 Finch Haven Avenue, Keysborough	129.90	''	28/05/97
Novak Victor, 192/530 Lygon Street, Carlton	117.15	''	09/11/97
O'Kane Michael, P.O. Box 6, Tungamah	284.00	''	23/02/97
Owen Gregory, 31/300 Rouse Street, Port Melbourne	380.86	''	22/06/97
Parkinson Craig, C/- State Trustees, P. O. Box 980H Melbourne	104.40	''	25/08/97
Pham Van, 53/127 Gordon Street, Footscray	179.30	''	01/10/97
Pohatu Lee, 7 Main Street, Tetahi Bay, Auckland	119.50	''	10/06/97
Robinson William, 351 Park Street, Brunswick East	145.50	''	30/11/97
Ryan Francis, 15/32 Ambon Street, Preston	151.28	''	08/06/97
Ryan Terrence, 12/13 Lovick Avenue, Mansfield	102.30	''	19/10/97
Scarff Darrell, 57 Trudewind Road, Wodonga	113.60	''	01/02/98
Seng Sokun, 4 Levoer Street, Dandenong North	187.15	''	13/04/97
Sou Nen, 5 Benga Avenue, Dandenong North	328.40	''	30/05/97
Sua Moe, Mrs Peka Sua, 4 Loddon Court, Thomastown	109.70	''	14/05/97
Taylor Paul, 153/332 Park Street, South Melbourne	137.05	''	04/07/97
Thomas Elizabeth, 2/1 Winston Street, Shepparton	102.40	''	01/06/97
Thomas George, 1/35 Swallow Street, Port Melbourne	120.70	''	31/07/97
Todorovic Milan, 6/43-47 Alamein Street, Noble Park	194.80	''	21/04/97
Ton Tong Hung, 55/95 Napier Street, Fitzroy	100.01	''	10/11/96
Tseremopoulos Tassos, 5/193 Elizabeth Street, Richmond	141.40	''	10/12/97
Tunc Mehmet, 2/2067 Gold Coast, Miami	104.10	''	16/03/97
Urquhart Charles, 14/114 Riversdale Road, Hawthorn	158.50	''	04/07/97
Valkyrie Richard, C/ Western General Hospital	112.80	''	16/03/97
Van Den Berg John, 173 Eley Road, Blackburn South	109.20	''	02/04/97
Young Thanh Bao, 2/2 Cooke Court, Richmond	115.90	''	23/09/97
Vychodil Frank, 32/530 Lygon Street, Carlton	162.10	''	29/06/97
Wagland Kenneth, 3/56A Dundas Street, St Arnaud	104.40	''	08/06/97
White Betty, 2/18 Churchill Avenue, Ascot Vale	107.70	''	02/03/97
Wright Roma, 174/351 Barkly Street, Brunswick	132.65	''	17/02/98
Young Annette, 43 Willunga Street, Port Land	140.60	''	08/06/97
Atkinson Bridgman & Associates, P.O. Box 253, Ivanhoe Body Corporate 21600E,	150.00	Cheque	20/01/97
C/- Stockdale & Leggo, P.O. Box 191 Bundoora	350.00	''	21/05/97
Body Corporate 31891H, 92 Willow Avenue, Rowville	235.00	''	19/12/96
Body Corporate 323239 IEA, Level 4-650 Chapel Street, South Yarra	109.10	''	28/03/97

Body Corporate 7294, 155-161 Toorak Road, South Yarra	150.00	”	27/12/96
Body Corporate 8925, C/- Mrs M. Batchelor, 8/36 Grevilla Rd, Oak Park	125.00	”	13/01/97
Bowden R. J., 15 Banksia Crescent, Churchill	411.47	”	16/05/97
Devlin J. & A. 7 Lilac Court, Frankston	119.30	”	15/04/97
Fowles Auction Group, P.O. Box 34, Altona	321.00	”	28/04/97
Lee H. F. 211/49 Union Street, Prahran	1,906.70	”	26/02/97
Lewis L., 89 / 159 Melrose Street, North Melbourne	139.00	”	20/05/97
Masterlink Communications, 195 Russell Street, Melbourne	120.00	”	20/12/96
Ngoc Anh Duong , 12 Margot Street, West Footscray	231.00	”	24/01/97
Optus Communications, Locked Bag 23, North Ryde, NSW	302.04	”	26/06/97
Registrar of Titles, 283 Queen Street, Melbourne	225.00	”	11/02/97
Registrar of Titles, 283 Queen Street, Melbourne	225.00	”	”
Terry & Phil Fencing One, 99 Fitzgerald Rd, Laverton North	262.50	”	11/07/97
Westpac Acc No 009276, 360 Collins Street, Melbourne	846.00	”	31/12/96

99135

CONTACT: ROBYN GUTHRIE, PHONE: (03) 9637 4302.

PROCLAMATIONS

Land Act 1958

PROCLAMATION OF ROADS

I, James Gobbo, Governor of Victoria acting with the advice of the Executive Council and under section 25(3)(c) of the **Land Act 1958**, proclaim as roads the following lands:

**MUNICIPAL DISTRICT OF THE
BALLARAT CITY COUNCIL**

BALLARAT — The lands in the Township of Ballarat, Parish of Ballarat shown by hatching on plan hereunder. (B128[65]) — (Rs 11405).

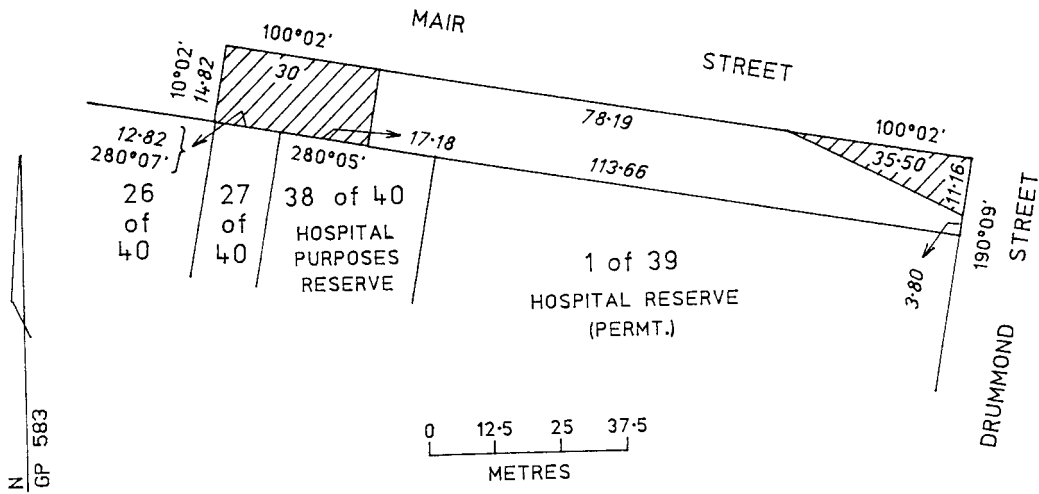

MUNICIPAL DISTRICT OF THE SURFCOAST SHIRE COUNCIL

BELLBRAE — The land in the Township of Bellbrae, Parish of Jan Juc shown by hatching on plan hereunder. (B799[1]) — (Rs 11643).

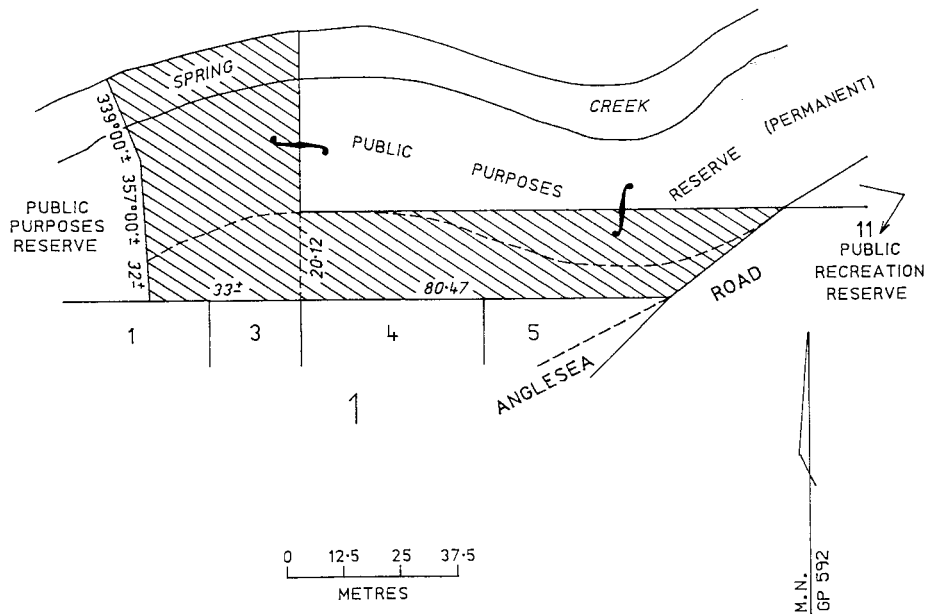

MUNICIPAL DISTRICT OF THE
GREATER BENDIGO CITY COUNCIL

BENDIGO, MANDURANG and SANDHURST — The lands At Bendigo and in the Parishes of Mandurang and Sandhurst shown by blue hatching on plan LEGL./98-15 lodged in the Central Plan Office. — (06/17043).

MUNICIPAL DISTRICT OF THE FRANKSTON CITY COUNCIL

LYNDHURST — The land in the Parish of Lyndhurst shown by hatching on plan hereunder. (L101[9]) — (L11-4604).

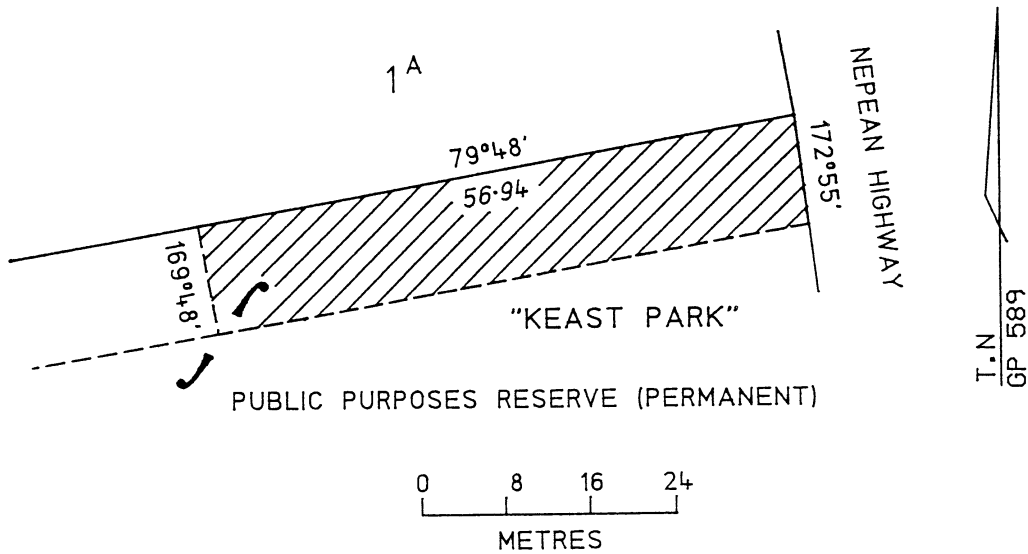

This Proclamation is effective from the date on which it is published in the Government Gazette.
Given under my hand and the seal of Victoria on 7 March 2000.

(L.S.)

JAMES GOBBO
Governor
By His Excellency's Command

SHERRYL GARBUTT MP
Minister for Environment and Conservation

**GOVERNMENT AND OUTER BUDGET SECTOR AGENCIES
NOTICES**

DAREBIN CITY COUNCIL

Declaration of Public Highway

Under section 204(1) of the **Local Government Act 1989** (the "Act") the Darebin City Council at its ordinary meeting held on 21 February 2000 formed the opinion that the road shown on the plan below is required to be opened to the public for traffic as of right and declared the road to be a public highway for the purposes of the Act on and from the publication of this notice in the Government Gazette.

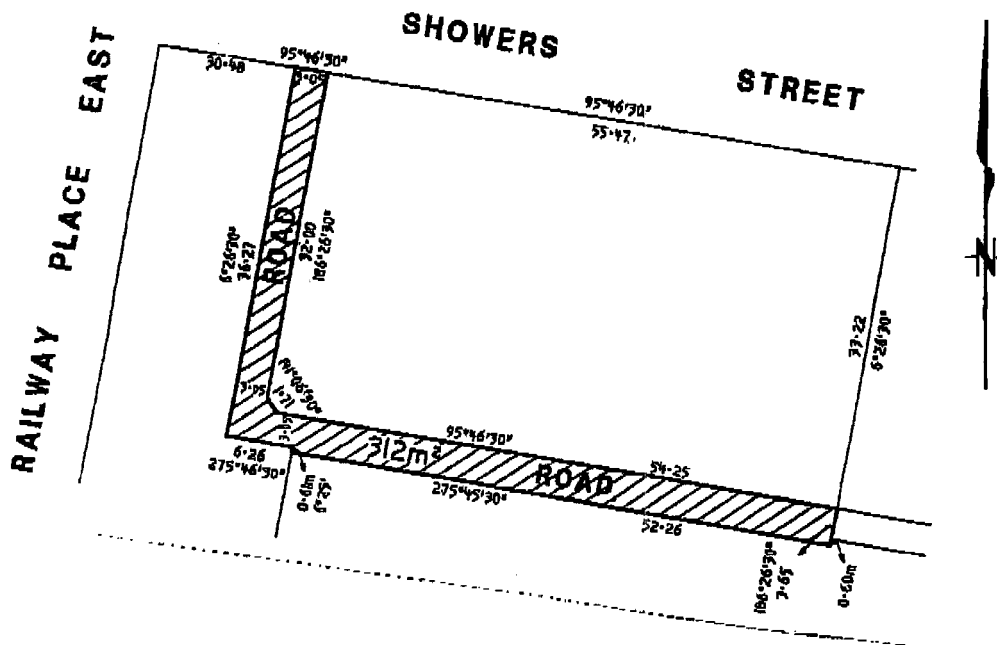

PHILIP SHANAHAN
Chief Executive Officer



DISCONTINUANCE OF PART OF CRANBOURNE & FLETCHER ROADS, FRANKSTON

Notice is hereby given that pursuant to Schedule 10, Clause 3 of Section 206 of the **Local Government Act 1989**, Council formed the opinion at its meeting held on 14 February 2000, that the sections of road as shown as hatched on Council Plan M615 below are not required for public use and, having complied with the provisions of the **Local Government Act 1989**, resolved that the said sections of Cranbourne Road and Fletcher Road be discontinued and the Fletcher Road land be sold by private treaty to Readings Entertainment Pty Ltd.

Council further resolved that: Stratus Networks continue to have and possess the same power, authority or interest in or in relation to the Cranbourne Road land shown hatched on the said plan, as it had or possessed prior to such discontinuance with respect to or in connection with any pipes or fittings laid or erected in, on or over such land for gas supply purposes.



Discontinuance of Road

Notice is hereby given that the Port Phillip City Council at its ordinary meeting of 20 December 1999, formed the opinion that the section of road shown hatched on the plan below is not reasonably required as a road for public use and resolved to discontinue the road, and having advertised and served notices regarding the proposed discontinuance and hearing submissions under Section 223 of the **Local Government Act 1989**, orders that the road abutting 124 and 118B Carlisle Street, St Kilda, be discontinued pursuant to Section 206 and Schedule 10, Clause 3 of the said Act, and the land of the discontinued road be sold by private treaty to the owners of the land abutting the road.

Melbourne Water has assets within the above section of the road and Melbourne Water's right will be protected by easements over the entire section of land.

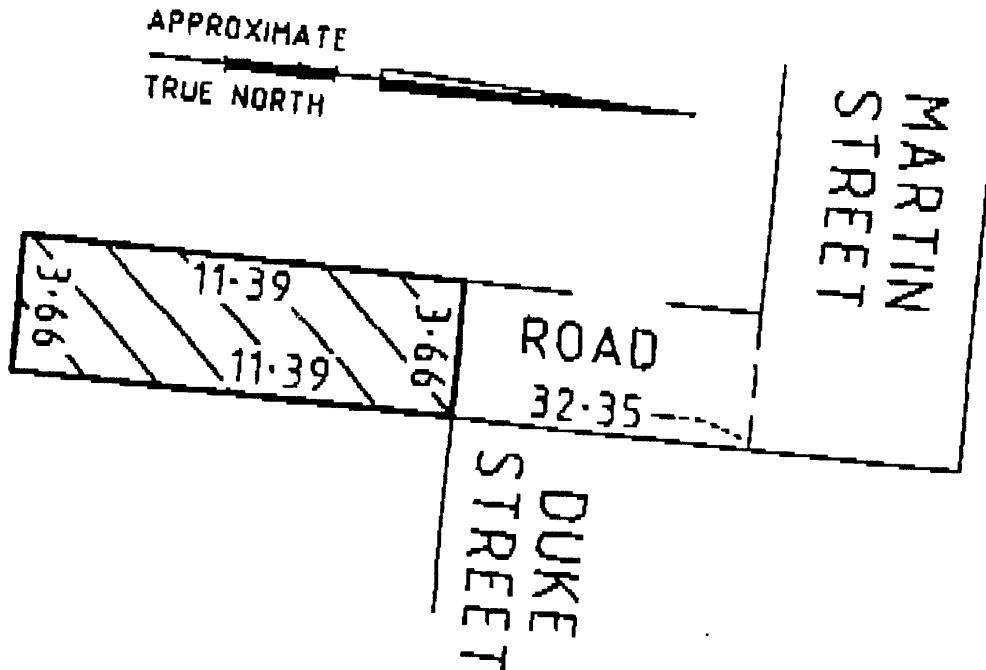

ANNE DUNN
Chief Executive Officer

GREATER DANDENONG CITY COUNCIL
Road Discontinuance

Under Section 206 and Schedule 10, Clause 3 of the **Local Government Act 1989**, the Greater Dandenong City Council, at its meeting held on 20 December 1999, formed the opinion that the road shown on the plan below is not reasonably required as a road for public use and resolved to discontinue the road and to sell the land from the road to the abutting owner subject to any right, power or interest held in the name of any public authority in the road in connection with any sewers, drains, pipes, wires and cable under the control of those authorities in or near the roads.

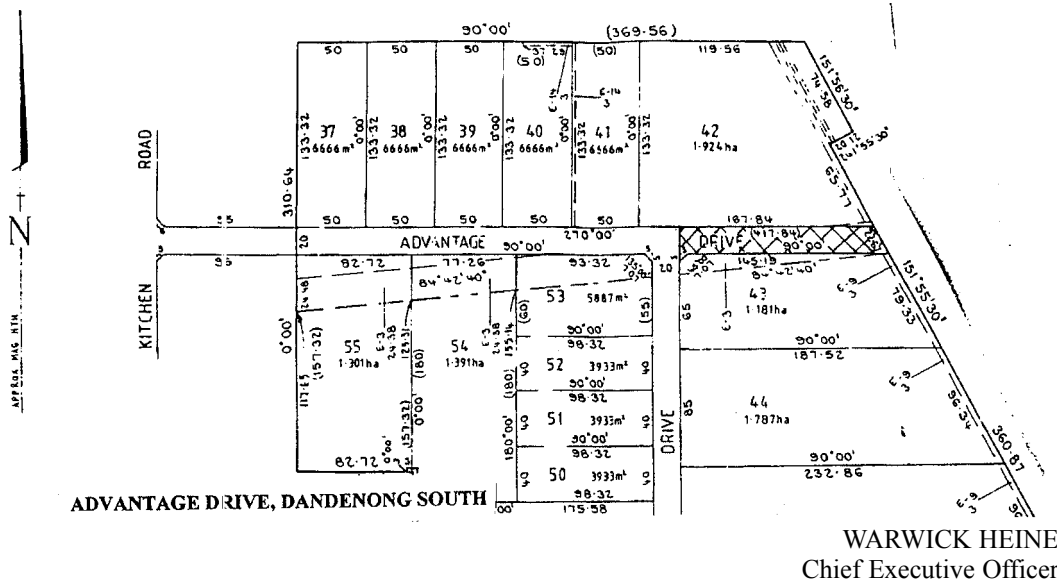

GLEN EIRA CITY COUNCIL
Road Discontinuance

Under Section 206 and Schedule 10 Clause 3 of the **Local Government Act 1989**, the Glen Eira City Council has formed the opinion that the road shown hatched on the plan below is not reasonably required as a road for public use and has resolved to discontinue the road and to sell the land from the road by private treaty.

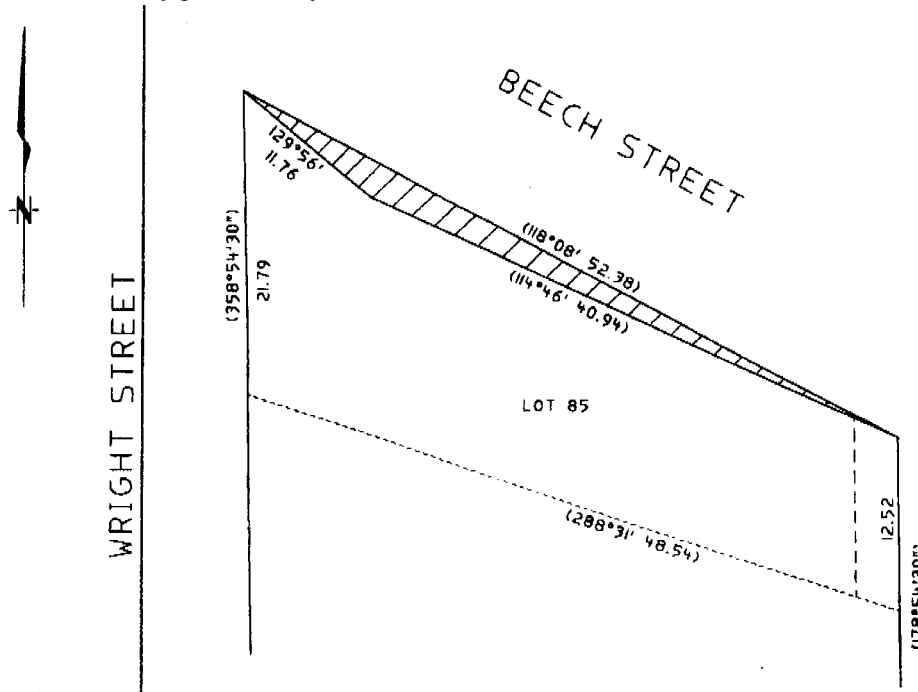

MACEDON RANGES SHIRE COUNCIL

Naming/Re-naming of Roads

Council recently undertook its public consultation process, inviting residents to forward a submission for the naming/re-naming of roads throughout the Shire as identified through the rural re-numbering program.

A recent alteration to the road identified below has been made.

No.:	Road Name	Road Name Determined
8	Naming of unnamed road off Trio Road, Kyneton	TRIO PLACE (formally determined as Dalzell Road)

GLEN EIRA CITY COUNCIL

Road Discontinuance

Under Section 206 and Schedule 10 Clause 3 of the **Local Government Act 1989** the Glen Eira City Council has formed the opinion that the road shown hatched and cross-hatched on the plan below is not reasonably required as a road for public use and has resolved to discontinue the road and to sell the land from the road by private treaty subject to any right, power or interest held by the Melbourne Water Corporation (South East Water) in the road in respect to the section of road shown cross-hatched and marked E-1 on the plan in connection with any sewers, drains or pipes under the control of that authority in or near the road.

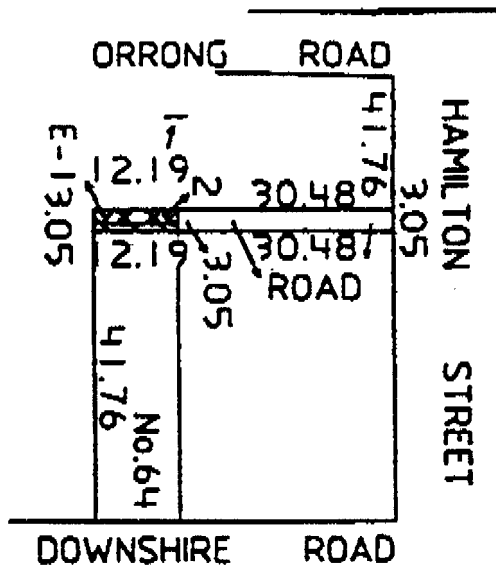

ANDREW NEWTON
Acting Chief Executive



LODDON
SHIRE COUNCIL

Public Holidays Act 1993

Pursuant to Section 7(1)(b) of the **Public Holidays Act 1993**, the Loddon Shire Council at its Ordinary Meeting held on 28 February 2000 resolved to declare a Public Holiday throughout the municipality on Tuesday 7 November 2000 (Melbourne Cup Day).

CRAIG W. NIEMANN
Chief Executive Officer



Authority to Enforce Alcohol Provision

Notice is hereby given, pursuant to Section 224 A(2) of the **Local Government Act 1989**, that any member of the Victoria Police Force stationed for the time being within the municipal district of Frankston may enforce the following provision of Frankston City Council's General Local Law 1999, Clause 2.3 Local Law No. 2, which reads:-

2.3 Alcohol

Unless otherwise authorised by Council, a person must not consume or have in his or her possession in any unsealed container, any alcohol on a road or in a municipal place."

JON EDWARDS
Chief Executive Officer

GLENELG SHIRE COUNCIL
Notice of Proposed Amendment

Meeting Local Law No. 1

The Glenelg Shire Council hereby gives public notice of its intention to amend Meeting Local Law No. 1.

Purpose

To amend Local Law No. 1 by revoking clause 3.15 thereof and substituting therefore:

3.15 Time limits for meetings

- (1) Council meetings or special committee meetings shall not continue beyond the time which Council has by resolution stipulated as the time at which such meetings shall conclude unless that time has been extended by resolution of that meeting made in accordance with Council's prior resolution as to the extension of time limits for meetings.
- (2) In the absence of such an extension, the meeting shall stand adjourned to a time, date and place to be then and there announced by the Chairperson.

Any person affected by the proposed amendment to the Local Law may make a submission within 14 days of the publication of this notice, in accordance with Section 223 of the **Local Government Act 1989**.

Any person requesting to be heard in support of their written submission is entitled to appear before a meeting of the Glenelg Shire Council (or Committee) either personally or by a person acting on his or her behalf and will be notified of the time and date of the hearing.

Enquiries should be directed to either Ms Deb Pendergast or Mr Trevor Hornby on (03) 5522 2257.

Submissions should be addressed to: "Amendment – Meeting Local Law No. 1", Mr Trevor Hornby, Administrative Services Manager, Glenelg Shire Council, P.O. Box 152, Portland, Vic. 3305.

Planning and Environment Act 1987
GREATER GEELONG PLANNING SCHEME
Notice of Amendment

Amendment L259

The City of Greater Geelong has prepared Amendment L259 to the Greater Geelong Planning Scheme.

The Amendment proposes to amend the Local Section of the Greater Geelong Planning Scheme to provide for the use and development of approximately 345m² at the rear of No. 12 Myers Street for an Office, subject to the subdivision of the land and consolidation into the adjoining property to the west (2 – 10 Myers Street).

The Amendment can be inspected at: City of Greater Geelong, 2nd Floor, 103 Corio Street, Geelong; Department of Infrastructure, Office of Planning, 63 McKillop Street, Geelong 3220 and Department of Infrastructure, Level 3 Plaza, Nauru House, 80 Collins Street, Melbourne 3000.

Submissions about the Amendment must be sent to the Planning Scheme Unit, City of Greater Geelong, P.O. Box 104, Geelong 3220, by Monday 3 April 2000.

CHUBB FADGYAS
Co-Ordinator Strategic Planning

Planning and Environment Act 1987
MOIRA PLANNING SCHEME

Notice of Amendment
Amendment C3

The Moira Shire Council has prepared Amendment C3 to the Moira Planning Scheme.

The Amendment affects Lot 2 and Part Lot 3 PS 68292 located at the corner of Dillon Street and Camber Court, Cobram. The land was formerly occupied by a VicRoads depot which has now become surplus to Government needs.

The Amendment proposes to rezone the land from the Public Use Zone (Service & Utility) to the Industrial 1 Zone.

The Amendment can be inspected free of charge during office hours at: Moira Shire Council offices, 99 Melville Street, Numurkah; Moira Shire Service Centres located in 26-30 Belmore Street, Yarrawonga and 44 Station Street, Cobram; Department of Infrastructure, North East Region, 50-52 Clarke Street, Benalla and Department of Infrastructure, Customer Service Centre, Upper Plaza, Nauru House, 80 Collins Street, Melbourne.

Submissions in writing about the Amendment must be sent to Mr Paul Flint, Manager Community Development, P.O. Box 132, Numurkah 3636, by Friday 7 April 2000.

Creditors, next of kin and others having claims against the estate of any of the undermentioned deceased persons are required to send particulars of their claims to State Trustees Limited, A.C.N 064 593 148, 168 Exhibition Street, Melbourne, Victoria 3000, the personal representative, on or before 11 May 2000 after which date State Trustees Limited may convey or distribute the assets having regard only to the claims of which State Trustees Limited then has notice.

BIRD, Henry Edward, late of Southport Community Nursing Home, 18 Richardson Street, Albert Park, retired, who died November 24, 1999.

BURMEISTER, Raymond Cecil, late of 36 Service Street, Hampton, retired, who died January 4, 2000.

CONNELLY, Edward Peter, late of 37 Phipps Crescent, Diamond Creek, retired, who died January 12, 2000.

DAWES, Doris, late of Unit 59, 466 Burwood Highway, Wantirna South, pensioner, who died December 22, 1999.

HAZELDINE, Herbert Hemsley, late of 695 Tooradin Station Road, Cardinia, pensioner, who died August 3, 1999.

MIRKOVICH, Slavko, late of 3-10 Valentine Grove, Armadale, pensioner, who died January 5, 2000.

ROBINSON, Harry, late of Latrobe Private Nursing Home, 14 Como Street, Alphington, pensioner, who died January 15, 2000.

ROCKLIFF, Hazel Rita, late of 360 Koornang Road, Carnegie, retired, who died December 31, 1999.

SILBER, Marjorie Grace, late of 28 Fowler Street, Bonbeach, pensioner, who died June 23, 1999.

SNOWDEN, Christeena, late of Rosehill Aged Care Facility, 12 Maxflo Court, Highett, pensioner, who died November 27, 1999.

TUCK Elsie Anne, late of 22 Piper Street, Fawkner, home duties, who died January 8, 2000.

Dated at Melbourne, 2 March 2000.

CATHY VANDERFEEN
Manager, Estate Management
State Trustees Limited

Creditors, next of kin and others having claims against the estate of any of the undermentioned deceased persons are required to send particulars of their claims to State Trustees Limited, A.C.N 064 593 148, 168 Exhibition Street, Melbourne, Victoria 3000, the personal representative, on or before 13 May 2000 after which date State Trustees Limited may convey or distribute the assets having regard only to the claims of which State Trustees Limited then has notice.

BADROCK, Brian Stanley, late of Unit 2, 17 Barrow Drive, Heathmont, retired, who died December 29, 1999.

DUNLOP, Norma Grace, late of 92 Gower Street, Preston, Public Servant, who died November 3, 1999.

HOWARD, Edith Ivy, late of Cambridge Nursing Home, 3 Cambridge Street, Collingwood, pensioner, who died December 4, 1999.

SMITH, Myrtle Ada Alice, late of 2c Pitt Street, Footscray, pensioner, who died January 19, 2000.

YOUNG, Ivy Irving, late of Strathdon Community Hostel, 17 Jolimont Road, Forest Hill, home duties, who died December 7, 1999.

Dated at Melbourne, 3 March 2000.

CATHY VANDERFEEN
Manager, Estate Management
State Trustees Limited

Creditors, next-of-kin and others having claims against the following estates:-

DE CAMPO, Ida Elizabeth, late of North West Hospital, Mount Royal Lodge Hostel, Carlton South, Victoria, pensioner, deceased intestate, who died on December 30, 1999.

MILLS, Janet Elizabeth Genevieve, late of Canterbury Private Nursing Home, 14 Balwyn Road, Canterbury, Victoria, retired, deceased, who died January 21, 2000.

MERRILLS, Eva Gwendoline Elizabeth, late of 4 Coventry Drive, Werribee, Victoria, home duties, deceased, who died February 1, 2000.

QUINN, Eileen Monica, late of 12/7 McGrath Court, Richmond, Victoria, retired, deceased intestate, who died January 12, 2000.

WILSON, Gary Leonard, late of Bentleigh

Continuing Care Unit, corner Warwick and Cardiff Streets, Bentleigh, Victoria, retired, deceased intestate, who died December 16, 1999.

Creditors, next-of-kin and others having claims against the abovementioned estates are required pursuant to Section 33 of the **Trustee Act 1958** to send particulars of their claims against the abovementioned estates to State Trustees Limited, 168 Exhibition Street, Melbourne, Victoria, on or before 13 May 2000 after which date State Trustees Limited, A.C.N. 064 593 148, may convey or distribute the assets of the abovementioned estates having regard only to the claims of which it then has notice.

EXEMPTION

Application No. A74 of 2000

The Victorian Civil and Administrative Tribunal has considered an application pursuant to Section 83 of the **Equal Opportunity Act 1995** by MacKillop Family Services Limited in respect of its St Joseph's Babies and Family Services. The application for exemption is to enable the applicant to recruit lead tenant volunteers between the age range of 23 – 45 years.

Upon reading the material tendered in support of this application the Tribunal is satisfied that it is appropriate to grant an exemption from Sections 13, 42, 49, 50, 100 and 195 of the Act to enable the applicant to recruit lead tenant volunteers between the age of 23 – 45 years.

In granting this exemption the Tribunal noted:

- MacKillop – St Joseph's conducts lead tenant service in the Western suburbs of Melbourne at three properties.
- In these residences, two young people aged 16 – 17 who are under Care and Protection live in these premises.
- The residents often suffer from challenging behaviours such as offending, drug usage and difficulty in interpersonal relationships.
- The aim of the service is to prepare the residents for the next step into independent living and to assist them in developing appropriate adult life skills.
- The role of the lead tenant (who lives in the residence provided by MacKillop Family

Services) is to act as a role model to these young residents who are on the verge of leaving care, in providing and assisting with independent living skills such as budgeting, cooking and developing appropriate support networks.

- It is the services experience that it is inadvisable to engage a very young lead tenant, because at times they have difficulty in separating their own developmental issues from those of the young residents. Gaining respect of the young people can also be an issue for a young lead tenant.
- The lead tenant needs to have sufficient life experience and maturity to respond appropriately to a range of challenging behaviours, and at the same time be able to role-model a satisfying and independent lifestyle as a young person themselves.
- The upper age limit of 45 years is sought to imply a youthful role model rather than a parental or authoritative figure.

The Tribunal grants an exemption from the operation of Sections 13, 42, 49, 50, 100 and 195 of the **Equal Opportunity Act 1995**, to enable the applicant to recruit lead tenant volunteers between the age range of 23 – 45 years.

This exemption is to remain in force from the day on which notice of the exemption is published in the Government Gazette until 8 March 2003.

Dated 3 March 2000.

Ms CATE MCKENZIE
Deputy President

EXEMPTION

Application No. A72 of 2000

The Victorian Civil and Administrative Tribunal has considered an application pursuant to Section 83 of the **Equal Opportunity Act 1995** by City of Greater Dandenong. The application for exemption is to enable the applicant to advertise and employ an Aboriginal or Torres Strait Islander person for the position of "Aboriginal Policy Officer".

Upon reading the material tendered in support of this application the Tribunal is satisfied that it is appropriate to grant an exemption from Sections 13, 100 & 195 of the

Act to enable the applicant to advertise and employ an aboriginal or Torres Strait Islander person for the position of "Aboriginal Policy Officer".

In granting the exemption the Tribunal noted:

- The role of "Aboriginal Policy Officer" requires somebody who can bring first hand knowledge of local Aboriginal issues back to the City of Greater Dandenong.
- This person would be able to tackle issues raised appropriately as well as establishing and strengthening closer links between Indigenous communities and the Council.
- An Aboriginal or Torres Strait Islander person would best fill the position so that the local Aboriginal community accepts them.

The Tribunal grants an exemption from the operation of Sections 13, 100 and 195 of the **Equal Opportunity Act 1995** to enable the applicant to advertise and employ an Aboriginal or Torres Strait Islander person for the position of "Aboriginal Policy Officer".

This exemption is to remain in force from the day on which notice of the exemption is published in the Government Gazette until 8 March 2003.

Dated this 3 March 2000.

Ms CATE McKENZIE
Deputy President

Department of Treasury and Finance

SALE OF CROWN LAND
BY PUBLIC AUCTION

Date of Auction: Friday 24 March 2000.

Reference No.: 99/01131.

Address of Property: McCallum Street, Swan Hill.

Crown Description: Allotment 12, Section 5, Parish: Swan Hill (Township).

Terms of Sale: Deposit 10%, Balance 60 days.

Area: 0.037 hectares.

Officer Co-ordinating Sale: Peter Jackel, Victorian Government Property Group, Department of Treasury and Finance, 10/1 Macarthur Street, Melbourne, Vic. 3002.

Selling Agent: Noel Watson Pty Ltd, 25 Campbell Street, Swan Hill.

JOHN BRUMBY MP
Minister for Finance

Department of Treasury and Finance

SALE OF CROWN LAND
BY PUBLIC AUCTION

Date of Auction: 25 March 2000 at 12.30 p.m. on site.

Reference: 99/01946.

Address of Property: Corner Central Springs Road & Midland Highway, Daylesford.

Crown Description: Crown Allotment 23A, Section 25A, Township of Daylesford.

Terms of Sale: Deposit 10%, Balance 60 days.

Area: 2013m².

Officer Co-ordinating Sale: Garry McKenzie, Garry McKenzie & Associates Pty Ltd. 1st Floor, City Centre Arcade, 315 Sturt Street, Ballarat, Vic. 3350.

Selling Agent: Doepel Lilley & Taylor, 41 Vincent Street, Daylesford, Vic. 3460.

JOHN BRUMBY MP
Minister for Finance

Department of Treasury and Finance

SALE OF CROWN LAND
BY PUBLIC AUCTION

Date of Auction: 8 April 2000 at 1.00 p.m. on site.

Reference: 99/01954.

Address of Property: Corner Sykes Avenue & Humffray Street South, Mount Pleasant.

Crown Description: Crown Allotment 12A, Section 15, Parish of Ballarat.

Terms of Sale: Deposit 10%, Balance 60 days.

Area: 3728m².

Officer Co-ordinating Sale: Garry McKenzie, Garry McKenzie & Associates Pty Ltd. 1st Floor, City Centre Arcade, 315 Sturt Street, Ballarat, Vic. 3350.

Selling Agent: L.J. Hooker, 615 Sturt Street, Ballarat, Vic. 3350.

JOHN BRUMBY MP
Minister for Finance

Department of Treasury and Finance

SALE OF CROWN LAND
BY PUBLIC AUCTION

Date of Auction: 8 April 2000 at 1.00 p.m. on site.

Reference: 99/02763.

Address of Property: Humffray Street South,
Mount Pleasant.

Crown Description: Crown Allotment 12B,
Section 15, Parish of Ballarat.

Terms of Sale: Deposit 10%, Balance 60 days.

Area: 2688m².

Officer Co-ordinating Sale: Garry McKenzie,
Garry McKenzie & Associates Pty Ltd. 1st
Floor, City Centre Arcade, 315 Sturt Street,
Ballarat, Vic. 3350.

Selling Agent: L. J. Hooker, 615 Sturt Street,
Ballarat, Vic. 3350.

JOHN BRUMBY MP
Minister for Finance

Marine Act 1988

NOTICE NO. 11 AMENDING NOTICE NO.1 MADE UNDER SECTION 15(2)

Notice is hereby given of the following amendments to Notice No.1 made under section 15(2) of the **Marine Act 1988** and published in the Government Gazette G26 on 2 July 1998.

These amendments were made by the Marine Board of Victoria on 28 February 2000 under section 15(2) of the **Marine Act 1988** on the recommendation of Commander Bob Johnson, a member of the Victoria Police.

Amendments to Notice No. 1

Amendments to Schedule 1 in Notice No.1

1. Amendments to Schedule 1

1. In Schedule 1 to Notice No.1 item 6 (f) substitute -

“(f) The waters described below are set aside exclusively for the use of vessels participating in, or associated with, the Victorian round of the Australasian Jetsport Boating Association, National Tour at Eastern Beach, Geelong on 18 and 19 March 2000, in daylight hours.

Exclusive zone: A zone delineated by an imaginary line commencing at a sign on the waters edge

approximately 80 metres east of the commencement of the concrete seawall adjacent to the Geelong Sailing and Water Safety School and extending approximately 275 metres northwards to a yellow inflatable buoy and then easterly approximately 300 metres to a second yellow inflatable buoy and then southerly approximately 100 metres to the wall of the Eastern Beach Swimming Pool and then following the wall south westerly to the waters edge.”.

2. For Item 7 of Schedule substitute -

“7. Expiration of temporary provisions.

(a) Item 1(c) shall cease to have effect at sunset on 19 March 2000.

(b) Item 6(f) shall cease to have effect at sunset on 19 March 2000.”.

Dated: 28 February 2000.

BRUCE PHILLIPS
Chief Executive
Marine Board of Victoria

Liquor Control Reform Act 1998

LIQUOR LICENSING POLL - CAMBERWELL NEIGHBOURHOOD

In the matter of an application by DBS Catering under the **Liquor Control Reform Act 1998** for an on-premises (restaurant) licence at 134-136 Highfield Road, Camberwell.

The resolution submitted to a poll on 19 February 2000 was:

“That an on-premises (restaurant) licence be granted in the neighbourhood of premises at 134-136 Highfield Road, Camberwell”.

The result of the poll was:

Votes polled for the resolution:	525
Votes polled against the resolution:	657
Informal votes polled:	5
Total votes polled:	1187

C.A. BARRY
Electoral Commissioner

Private Agents Act 1966**NOTICE OF RECEIPT OF APPLICATIONS FOR LICENCES UNDER THE PROVISIONS OF THE PRIVATE AGENTS ACT 1966**

I, the undersigned, being the Deputy Registrar of the Melbourne Magistrates' Court hereby give notice that applications, as under have been lodged for hearing by the said Court on the date specified.

Any person desiring to object to any such application must:

- (a) lodge with me a notice in the prescribed form of his objection and of the grounds thereof;
- (b) cause a copy of such notice to be served personally or by post upon the applicant at least three days before the hearing of the application; and
- (c) send or deliver
 - (i) where the objection is not made by the officer in charge of the police district in which the Court is situated — a copy of the notice to such officer; and
 - (ii) where the objection is not made by the Registrar or Deputy Registrar — a copy to the Registrar.

<i>Full name of Applicant or in the case of a Firm or Corporation, of the Nominee</i>	<i>Place of Abode of Applicant or Nominee</i>	<i>Name of Firm or Corporation</i>	<i>Address for Registration</i>	<i>Type of Licence</i>	<i>Date of Hearing of Application</i>
Ralph Andrew Blakeley	4 Scott Street, Beaumaris, Vic. 3193	Melbourne Markets Credit Service Pty Ltd	P.O. Box 560 Footscray Vic. 3011	Commercial Agent	10/4/2000
Richard John Burgess	58 Harrison Avenue, Burwood, Vic. 3125	Gessbur Pty Ltd trading as B & F Associates	16 Baker Street, Richmond Vic. 3121	Commercial Agent	10/4/2000
Donald Arthur Coulthard	10 Wyola Court, Rowville, Victoria	Credit Solutions Australia	Level 5, 313 La Trobe Street, Melbourne	Commercial Agent	10/4/2000
Carol Glenys Pope	12 Pelican Court, Chelsea Heights	Collection House Pty Ltd	4th Floor, 24 Albert Road, South Melbourne	Commercial sub-agent	10/4/2000
Ray Glaser	22 Kiewa Crescent, Dallas	Quartermain Support Services	3rd Floor, 423 Bourke Street, Melbourne	Commercial sub-agent	10/4/2000
Sylvia Lustro	5 Emma Court, Thomastown	Advanced Credit Management	5 Emma Court, Thomastown	Commercial sub-agent	10/4/2000
Friedhelm Johann Fleer	145 Eramosa Road, Somerville	Quartermain Support Services	3rd Floor, 423 Bourke Street, Melbourne	Commercial sub-agent	10/4/2000

Christopher Holmes Richardson	47 Brownfield Street, Parkdale Vic. 3195	Dun & Bradstreet Australia Pty Ltd	479 St. Kilda Road, Melbourne Vic. 3004	Commer- cial Agent	10/4/2000
Chris Kakos	76 Saronvale Crescent, Hillside 3037	Pacific Mercantile	Level 10, 388 Lonsdale Street, Melbourne Victoria	Commer- cial sub- agent	10/4/2000
Eunice Catherine Sissing	8 Fernshaw Gardens, Hallam, Vic. 3803	Collection House Pty Ltd	4th Floor, 24 Albert Road, South Melbourne, Vic. 3205	Commer- cial sub- agent	10/4/2000

PETER MITHEN
Deputy Registrar Melbourne Magistrates' Court

Geographic Place Names Act 1998

REGISTRATION OF AMENDMENT OF GEOGRAPHIC NAMES

The Registrar of Geographic Names hereby gives notice of the registration of amendment of the undermentioned place names.

File No.	Place Names	Proposer & Location
GPN 270	From Forest Creek Bridge to Noel Tuohey Bridge.	Shire of Campaspe. At Campaspe, extending across Forest Creek on the Barnadown-Myola Road.
GPN 276	From Kings Park Secondary College Delahey Senior Campus to Copperfield College Delahey Senior Campus.	Department of Education. Goldsmith Avenue, Delahey.
GPN 277	From Kings Park Secondary College Kambalda Junior Campus to Copperfield College Kings Park Junior Campus.	Department of Education. Kambalda Circuit, Kings Park.
GPN 278	From Portsea Recreation Reserve to Percy Cerutty Oval.	Mornington Peninsula Shire Council. Blair Road, Portsea.

Office of the Registrar of Geographic Names.

c/-LAND VICTORIA
2nd Floor
456 Lonsdale Street
MELBOURNE 3000

JOHN PARKER
Registrar Geographic Names

Road Safety Act 1986

EXTENDING PROVISIONS TO LAND AT STATION PIER CAR PARK IN THE CITY OF PORT PHILLIP

I, Brian John Negus, Regional Manager – Metropolitan North West Region of the Roads Corporation, under the powers delegated to me by the Minister for Transport, and under Section 98 of the **Road Safety Act 1986**, by this Order extend the application of:

- (a) Sections 59, 64, 65, 76, 77, 85-90, 99 and 100 of that Act; and
- (b) The Road Safety (Traffic) Regulations 1988; and
- (c) Parts 5 and 6 and Schedules 3 and 4 of the Road Safety (General) Regulations 1999 – to land at Station Pier Car Park, particulars of which are shown on the attached plan, vested in or under the control of the City of Port Phillip.

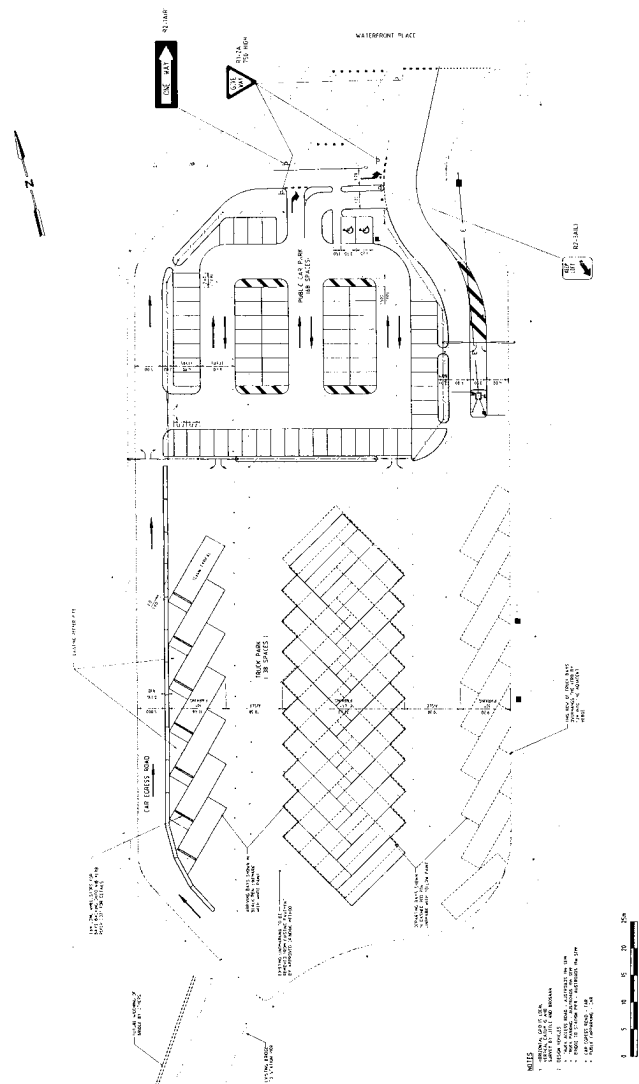

Dated 25 February 2000.

BRIAN NEGUS
Regional Manager – Metropolitan North West
Roads Corporation

Road Safety Act 1986

EXTENDING PROVISIONS TO SOUTHGATE PLAZA LOADING ZONES SOUTHBANK IN THE CITY OF MELBOURNE

I, Brian John Negus, Regional Manager – Metropolitan North West Region of the Roads Corporation, under the powers delegated to me by the Minister for Transport, and under Section 98 of the **Road Safety Act 1986**, by this Order extend the application of:

- (a) Sections 59, 64, 65, 76, 77, 85-90, 99 and 100 of that Act; and
- (b) The Road Safety (Traffic) Regulations 1988; and
- (c) Parts 5 and 6 and Schedules 3 and 4 of the Road Safety (General) Regulations 1999 – to land at Southgate Plaza, Southgate Avenue, Southbank particulars of which are shown hatched on the attached plan, vested in or under the control of the City of Melbourne.

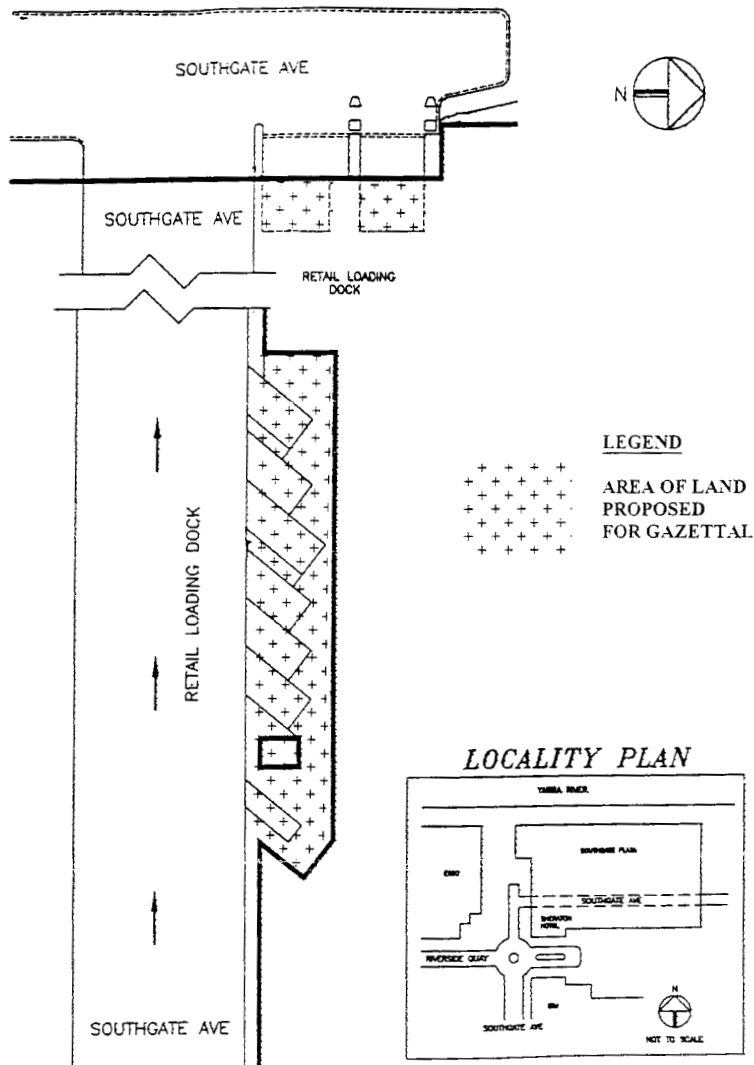

Dated 25 February 2000.

BRIAN NEGUS
 Regional Manager – Metropolitan North West
 Roads Corporation

Road Safety Act 1986
EXTENDING PROVISIONS TO LAND AT POWELL DRIVE CAR PARK
HOPPERS CROSSING
IN THE CITY OF WYNDHAM

I, Brian John Negus, Regional Manager – Metropolitan North West Region of the Roads Corporation, under the powers delegated to me by the Minister for Transport, and under Section 98 of the **Road Safety Act 1986**, by this Order extend the application of:

- (a) Sections 59, 64, 65, 76, 77, 85-90, 99 and 100 of that Act; and
 - (b) The Road Safety (Traffic) Regulations 1988; and
 - (c) Parts 5 and 6 and Schedules 3 and 4 of the Road Safety (General) Regulations 1999 –
- to land at Powell Drive, Hoppers Crossing particulars of which are shown hatched on the attached plan, vested in or under the control of the Wyndham City Council.

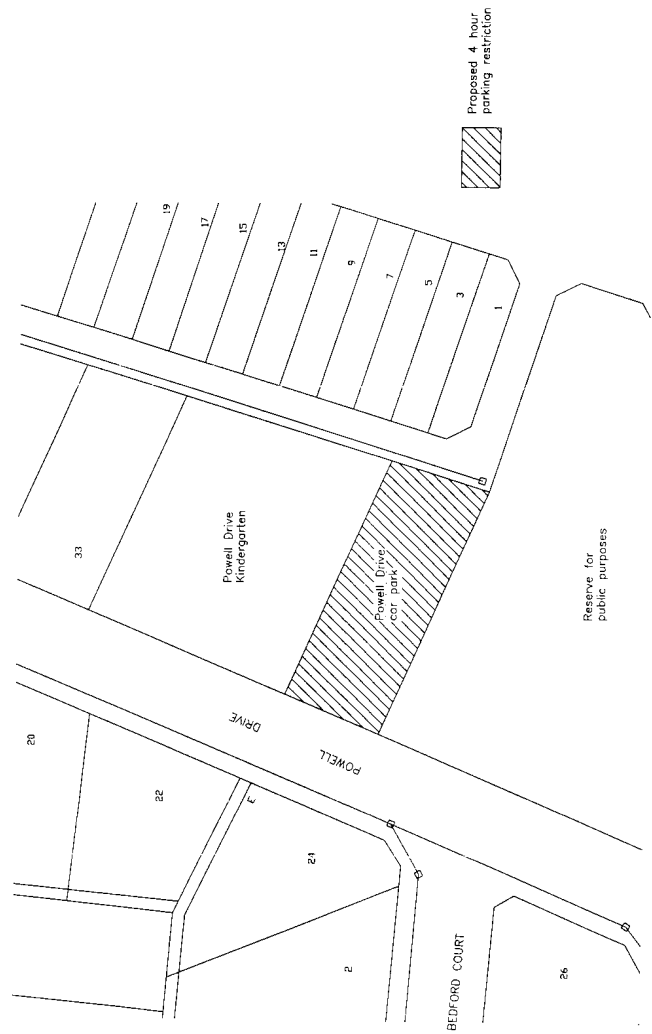

Dated 25 February 2000.

BRIAN NEGUS
Regional Manager – Metropolitan North West
Roads Corporation

Docklands Authority Act 1991

DOCKLANDS AUTHORITY

Road Declarations and Dedications

The Docklands Authority pursuant to the powers vested in it by the **Docklands Authority Act 1991** as amended and the **Local Government Act 1989** as amended, upon publication of this notice declares, the roads described below and on the plans referred to as roads fit to be used as public highways and dedicates these roads to the public for use as public highways within the meaning of any law or hereafter in force.

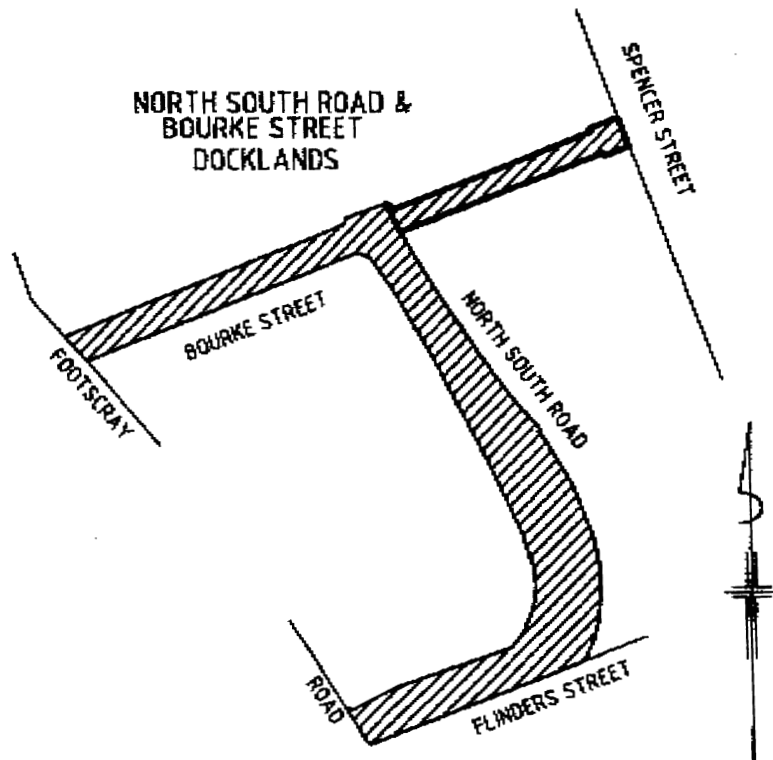

NOTE: THE HEAVIEST LINED PARCEL
 1. LOWER LIMIT - UPPER SURFACE OF ROAD
 2. HAS UPPER LIMIT.

COMPILED FROM
 PS 431458V
 PS 434050P
 PS 434051M

PLAN FOR ROAD PROCLAMATION PURPOSES

**PARISH OF MELBOURNE NORTH
CITY OF MELBOURNE**

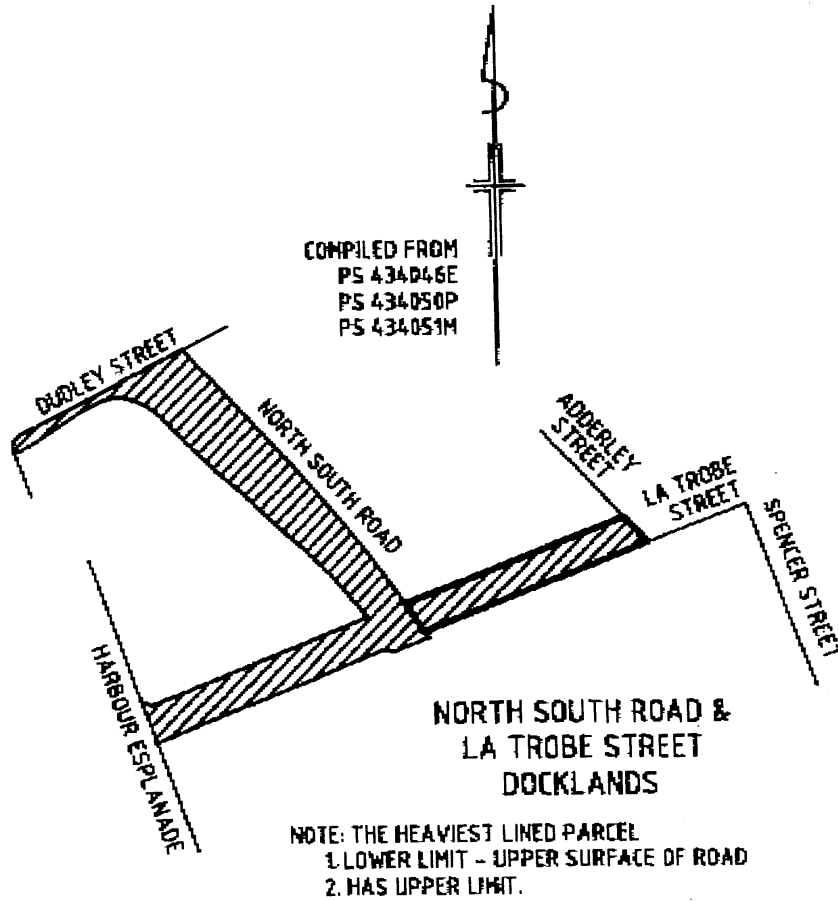

PLAN FOR ROAD PROCLAMATION PURPOSES

PARISH OF MELBOURNE NORTH
CITY OF MELBOURNE

PETER ANDERSON
City Manager

Interpretation of Legislation Act 1984**RESIDENTIAL TENANCIES (CARAVAN PARKS REGISTRATION AND STANDARDS) REGULATIONS 1999**

As required by section 32 of the **Interpretation of Legislation Act 1984**, I give notice that the Residential Tenancies (Caravan parks Registration and Standards) Regulations 1999 apply, adopt or incorporate the following documents:

Schedule 1; Clause 1(6) of Schedule 3; Clause 2(3) of Schedule 4	Australian Standard 1288-1994, Glass in buildings- Selection and installation	Whole document
Schedule 1; Clauses 1(5) and 9(4) of Schedule 3	Australian Standard 1170.1-1989, Loading Code Part 1: Dead and live loads and load Combinations	Whole document
Schedule 1; Clauses 1(5) and 9(4) of Schedule 3	Australian Standard 1170.2-1989, Loading Code Part 2: Wind loads	Whole document
Schedule 1; Clause 6(1) of Schedule 3	Australian Standard 3000-1991, Wiring Rules	Whole document
Schedule 1; Clause 6(1) of Schedule 3	Australian Standard 3001-1990, Electrical Installations Installations: movable premises (including caravans) and their site installations	Whole document
Schedule 1; Clause 2(1) of Schedule 4	Australian Standard 3005-1982, Electrical Installations of tents and similar temporary structures for domestic purposes	Whole document
Schedule 1; Clause 6(2) of Schedule 3; Clause 2(2) of Schedule 4	Australian Standard 3500.1.1 -1998, National Plumbing And Drainage Part 1.1: Water Supply - Performance requirements	Whole document
Schedule 1; Clause 6(2) of Schedule 3; Clause 2(2) of Schedule 4	Australian Standard 3500.1.2 -1998*, National Plumbing And Drainage Part 1.2: Water Supply - Acceptable solutions	Whole document
Schedule 1; Clause 6(2) of Schedule 3; Clause 2(2) of Schedule 4	Australian Standard 3500.2.1-1996, National Plumbing and Drainage Part 2.1: Sanitary Plumbing and Drainage- Performance requirements	Whole document
Schedule 1; Clause 6(2) of Schedule 3; Clause 2(2) of Schedule 4	Australian Standard 3500.3.1-1998, National Plumbing And Drainage Part 3.1: Stormwater Drainage- Performance requirements	Whole document
Schedule 1; Clause 6(2) of Schedule 3; Clause 2(2) of Schedule 4	Australian Standards 3500.4.1-1997, National Plumbing And Drainage Part 4.1: Hot Water Supply Systems- Performance requirements	Whole document
Schedule 1 and Regulations 25 and 26	Australian Standard 3786-1993, Smoke Alarms	Whole document
Schedule 1; Clause 6(2) of Schedule 3; Clause 2(2) of Schedule 4	Australian Standard/New Zealand Standard 3500.2.2-1996 National Plumbing and Drainage Part 2.2: Sanitary Plumbing and Drainage-Acceptable solutions	Whole document

Schedule 1; Clause 6(2) of Schedule 3; Clause 2(2) of Schedule 4	Australian Standard/New Zealand Standard 3500.3.2-1998, National Plumbing and Drainage part 3.2: Stormwater Drainage - Acceptable solutions	Whole document
Schedule 1; Clause 6(2) of Schedule 3; Clause 2(2) of Schedule 4	Australian Standard/New Zealand Standard 3500.4.2-1997 National Plumbing and Drainage part 4.2: Hot Water Supply Systems - Acceptable solutions	Whole document
Clause 2(a) of Schedule 5	Building Code of Australia 1996 Table F2.1	Table F2.1

*Note: due to a typographical error, the date of this standard was incorrectly stated as "1996" in the Regulations, and it is proposed to amend the Regulation to correct this error.

A copy of the material applied, adopted or incorporated by the regulation was lodged with the Clerk of the Parliaments on 24 November 1999.

JOHN THWAITES
Minister for Planning

Gaming and Betting Act 1994

APPROVED BETTING COMPETITION

The following class of events and contingencies is approved as a betting competition conducted on a totalisator under section 64 of the **Gaming and Betting Act 1994**.

Motor Sport – races controlled and regulated by national and international authorities.

Dated 25 February 2000.

JOHN PANDAZOPOULOS MP
Minister for Gaming
ROB HULLS MP
Minister for Racing

Country Fire Authority Act 1958

VARIATION OF FIRE DANGER PERIOD

In pursuance of the powers conferred by Section 4 of the **Country Fire Authority Act 1958**, I, Leonard Raymond Lester, Chairman of the Country Fire Authority, after consultation with the Secretary of Natural Resources and Environment, hereby vary the declaration of the Fire Danger Periods previously published in the Government Gazette by declaring that such Fire Danger Periods shall end in respect of the undermentioned Municipal Districts of Municipalities or parts of Municipalities specified.

To terminate from 01.00 hours on 14 March 2000.

Hindmarsh Shire Council

Horsham Rural City Council (Part) – That part north of the line described by the following roads:- Bow Lake Fire Access Road, Bow Lake Road, Jallumba/Clear Lake Road, Jallumba/Mockinya Road, Wonwondah/Toolondo Road, North East Wonwondah Road, Grampians Road, Wonwondah/Dadswells Bridge Road, Fullbrooks Road to the Wimmera River.

Yarriambiack Shire Council

West Wimmera Shire Council (Part) – That part north of the line described by the following roads:- Elliots Road, Northern Break, McDonald Highway.

Buloke Shire Council.

Gannawarra Shire Council.

Mildura Rural City Council.

Swan Hill Rural City Council.

L. FOSTER
Chairman

Education Act 1958

NOTICE OF MAKING OF AN ORDER UNDER SECTION 13

An Order of the Minister for Education was made on 26 February 2000 under sections 13(4), 13(5) and 13(11) of the **Education Act 1958** dissolving the Carrajung Primary School Council and making consequential arrangements.

MARY DELAHUNTY
Minister for Education

Education Act 1958NOTICE OF MAKING OF AN ORDER
UNDER SECTION 13

An Order of the Minister for Education was made on 26 February 2000 under sections 13(4), 13(5) and 13(11) of the **Education Act 1958** dissolving the Nilma North Primary School Council and making consequential arrangements.

MARY DELAHUNTY
Minister for Education

Land Acquisition and Compensation Act 1986

FORM 7 S.21
Reg.16

NOTICE OF ACQUISITION

Compulsory Acquisition of Interest in Land

Roads Corporation (VicRoads) declares that by this notice it acquires the following interest in the land described as Part of Crown Allotment 4, Crown Section D, Parish of Wurruk Wurruk comprising 4.601 hectares and being land described in Certificate of Title Volume 7251 Folio 081, shown as Parcel 4 on VicRoads Survey Plan 19725.

Interest Acquired: That of Henry, Glenda, Edna and John HEYWOOD and all other interests.

Published with the authority of VicRoads.

The Survey plan referred to in this notice may be viewed at the office of Property Services Department, VicRoads, 60 Denmark Street, Kew. Dated 9 March 2000.

For and on behalf of VicRoads:
T. H. HOLDEN
Manager Property Services Department

Land Acquisition and Compensation Act 1986

FORM 7 S.21
Reg.16

NOTICE OF ACQUISITION

Compulsory Acquisition of Interest in Land

Roads Corporation (VicRoads) declares that by this notice it acquires the following interest in the land described as Part of Crown Allotment 41, Crown Section A, Parish of Coolungoolun comprising 9261 square metres and being land described in Certificate of Title Volume 8163 Folio 785, shown as Parcel 3 on VicRoads

Survey Plan 19726.

Interest Acquired: That of Kenneth and Alison BOULTON and all other interests.

Published with the authority of VicRoads.

The Survey plan referred to in this notice may be viewed at the office of Property Services Department, VicRoads, 60 Denmark Street, Kew. Dated 9 March 2000.

For and on behalf of VicRoads:
T. H. HOLDEN

Manager Property Services Department

Associations Incorporation Act 1981

SUB-SECTION 36E(5)

Notice is hereby given that the incorporation of the associations mentioned below will be cancelled in accordance with Section 36E(3) of the **Associations Incorporation Act 1981** unless the Association notifies the Registrar within 28 days as to reasons why its incorporation should not be cancelled.

Victorian Taekwondo Federation Inc., Australian Dutch Community Services Inc., Gayline Support Services Inc., Korong Vale Football Club Inc., International Baptists Inc., Echuca BMX Club Inc., Camberwell Youth Participation Inc., Australian Glass and Glazing Association Inc., Eltham Community Youth Club Inc., Indo-China Refugee Association (Vic.) Inc., Library Promotion Committee of Victoria Inc., The Victorian Squash Rackets Association Inc., Bendigo Community Youth Support Scheme Inc., Old Ballarat Royal Tennis Club Inc., The Fashion Design Council of Australia Inc., The Shan Foundation Inc., Folklore Ensemble "Vuk Karadzic" Melbourne Inc., Geelong Motor Racing Association Inc., The School of Total Education Parents & Friends Association Inc., United Bridgewater Cricket Club Inc., King of the Mountain Committee Inc., Goulburn Valley Region Employment Development Board Inc., Sea Urchins Dive Club Inc., Geelong Maritime Society Inc., Echuca Table Tennis Association Inc., Arnold Street Tennis Club Inc., Altona Lacrosse Club Inc., Rochester Squash Club Inc., Beechworth Theatre Group Inc., Kyabram Community Youth Support Scheme Inc., Glenhuntley Rehabilitation Centre Parents' Association Inc., Eastern Darts Centre Inc.,

Newport Central Football Club Inc., Loddon-Campaspe Regional Housing Council Inc., Mandurang Arts and Orchid Festival Inc., Glenelg Regional Information Network Inc., Echuca Cyss Centre Inc., Northies Basketball Club Inc., West Bendigo Sports Complex Inc., Demons Junior Football Club Inc., Stuart Mill Cricket Club Inc., Blackcross Racing Club Inc., Port Welshpool Professional Fishermans Association Inc., Leopold Netball Club Inc., Metal Mickey Mob Social Club Inc., Toolern Vale Community Pre-School Centre Inc., Hamilton Skin & Scuba Diving Club Inc., Echuca Motor Cycle Club Inc., Greater Shepparton Development Committee Inc.

Dated 29 February 2000.

WAYNE NEW
Deputy Registrar of
Incorporated Associations



Heritage Act 1995
NOTICE OF REGISTRATION

As Executive Director for the purpose of the Heritage Act, I give notice under section 46 that the Victorian Heritage Register is amended in that the Heritage Register Number 42 in the category described as a Heritage Place is now described as:

Former Metropolitan Meat Market, 1-3 Blackwood Street and 42 Courtney Street, North Melbourne, Melbourne City Council.

EXTENT:

1. All the buildings and structures being B1 Main Market building and Hotel, B2 Garage as marked on Diagram 42 held by the Executive Director.

2. All the land marked L1 on Diagram 43 held by the Executive Director, being described in Vol. 1212 Fol. 315 being part of Crown Allotments 21, Section 11 at North Melbourne Parish of Jika Jika; Vol. 2767 Fol. 274 being Crown Allotment 18, Section 11 at North Melbourne Parish of Jika Jika; Vol. 4357 Fol. 255 being part of Crown Allotment 19, Section 11 at North Melbourne Parish of Jika Jika; Vol. 4500 Fol. 945 being part of Crown Allotment

19, Section 11 at North Melbourne Parish of Jika Jika; Vol. 2239 Fol. 636 being part of Crown Allotment 17, Section 11 at North Melbourne Parish of Jika Jika; Vol. 3256 Fol. 001 being Crown Allotments 1, 2 and 20 and part of Crown Allotments 3 and 16, Section 11 at North Melbourne Parish of Jika Jika; Vol. 3761 Fol. 119 being part of Crown Allotment 19, Section 11 at North Melbourne Parish of Jika Jika.

Dated: 3 March 2000.

RAY TONKIN
Executive Director



Heritage Act 1995

NOTICE OF REGISTRATION

As Executive Director for the purpose of the Heritage Act, I give notice under section 46 that the Victorian Heritage Register is amended in that the Heritage Register Number 797 in the category described as a Heritage Place is now described as:

Burlington Terrace, 15-17 Lansdowne Street and 384-400 Albert Street, Melbourne City Council.

EXTENT:

1. All the buildings and structures being B1 Terrace Houses, B2 Toilets, B3 Terrace Houses, B4 Terrace Houses, B5 Wall, B6 Stables as marked on Diagram 797 held by the Executive Director.

2. All the land marked L1 on Diagram 797 held by the Executive Director, being described in Vol. 4471 Fol.100, Vol. 4471 Fol. 101, being part of Crown Allotment 16, Section 2 at East Melbourne, Parish of North Melbourne, Vol. 5009 Fol. 735, being part of Crown Allotments 15 and 16, Section 2 at East Melbourne, Parish of North Melbourne, Vol. 5009 Fol. 734, being part of Crown Allotment 15, Section 2 at East Melbourne, Parish of North Melbourne, Vol. 8205 Fol. 309, being part of Crown Allotments 12,13,14 and 15, Section 2 at East Melbourne, Parish of North Melbourne, Vol. 10237 Fol. 951, being part of Crown Allotments 12, 13 and 14, Section 2 at East Melbourne, Parish of North

Melbourne, Vol. 4471 Fol. 097, being part of Crown Allotments 12, 13 and 14, Section 2 at East Melbourne, Parish of North Melbourne, Vol. 4471 Fol. 099 being part of Crown Allotments 12, 13, 14, 15 and 16, Section 2 at East Melbourne, Parish of North Melbourne, Vol. 4471 Fol. 098 being part of Crown Allotments 12 and 15, Section 2 at East Melbourne, Parish of North Melbourne, Vol. 10184 Fol.773 being Lot 19 on Plan of Subdivision no. 327850C- derived from Vol. 4393 Fol. 459, Vol. 10184 Fol. 774 being Lot 21 on Plan of Subdivision no. 327850C- derived from Vol. 4393 Fol. 459, Vol. 10184 Fol. 775 being Lot 23 on Plan of Subdivision no. 327850C- derived from Vol. 4393 Fol. 459, Vol. 10184 Fol.776 being Lot 25 on Plan of Subdivision no. 327850C- derived from Vol. 4393 Fol. 459, Vol. 10184 Fol. 777 being Lot 27 on Plan of Subdivision no. 327850C- derived from Vol. 4393 Fol. 459.

Dated: 3 March 2000.

RAY TONKIN
Executive Director



Heritage
VICTORIA

Heritage Act 1995

NOTICE OF REGISTRATION

As Executive Director for the purpose of the Heritage Act, I give notice under section 46 that the Victorian Heritage Register is amended by including the Heritage Register Number 1867 in the category described as a Heritage place:

Tram Shelter, Corner St Kilda Road and Lorne Street, Melbourne, Port Phillip City Council.

EXTENT:

1. All the building being the tram shelter marked B1 on plan 1867 held by the Executive Director.
2. All the land to the extent of the eaves overhang marked L1 on Plan 1867 held by the Executive Director.

Dated: 3 March 2000.

RAY TONKIN
Executive Director



Heritage
VICTORIA

Heritage Act 1995

NOTICE OF REGISTRATION

As Executive Director for the purpose of the Heritage Act, I give notice under section 46 that the Victorian Heritage Register is amended by including the Heritage Register Number 1865 in the category described as a Heritage place:

Swimming Pool, Spring Creek, The Pool Way, Hepburn Springs, Hepburn Shire Council.

EXTENT:

1. All the built features including the terracing, hewn step work, pool, edging, weir, bridges, foundations and the like but excluding the picnic shelters, barbecues, contemporary seating and tables.
2. All the land marked L1 Diagram Number 1865 held by the Executive Director being part of the Hepburn Mineral Springs Reserve.

Dated: 3 March 2000.

RAY TONKIN
Executive Director



Heritage
VICTORIA

Heritage Act 1995

NOTICE OF REGISTRATION

As Executive Director for the purpose of the Heritage Act, I give notice under section 46 that the Victorian Heritage Register is amended by including the Heritage Register Number 1868 in the category described as a Heritage place:

Tram Shelter, Corner St Kilda Road and High Street, Melbourne, Port Phillip City Council.

EXTENT:

1. All the building being the tram shelter marked B1 on plan 1868 held by the Executive Director.
2. All the land to the extent of the eaves overhang marked L1 on Plan 1868 held by the Executive Director.

Dated: 3 March 2000.

RAY TONKIN
Executive Director



Heritage
VICTORIA

Heritage Act 1995

NOTICE OF REGISTRATION

As Executive Director for the purpose of the Heritage Act, I give notice under section 46 that the Victorian Heritage Register is amended by including the Heritage Register Number 1869 in the category described as a Heritage place:

Tram Shelter, Corner St Kilda Road and Dorcas Street, Melbourne, Port Phillip City Council.

EXTENT:

1. All the building being the tram shelter marked B1 on plan 1869 held by the Executive Director.
2. All the land to the extent of the eaves overhang marked L1 on Plan 1869 held by the Executive Director.

Dated: 3 March 2000.

RAY TONKIN
Executive Director



Heritage
VICTORIA

Heritage Act 1995

NOTICE OF REGISTRATION

As Executive Director for the purpose of the Heritage Act, I give notice under section 46 that the Victorian Heritage Register is amended by including the Heritage Register Number 1870 in the category described as a Heritage place:

Tram Shelter, Corner MacArthur Street and St Andrews Place, East Melbourne, Melbourne City Council.

EXTENT:

1. All the building being the tram shelter marked B1 on plan 1870 held by the Executive Director.
2. All the land to the extent of the eaves overhang marked L1 on Plan 1870 held by the Executive Director.

Dated: 3 March 2000.

RAY TONKIN
Executive Director



Heritage
VICTORIA

Heritage Act 1995

NOTICE OF REGISTRATION

As Executive Director for the purpose of the Heritage Act, I give notice under section 46 that the Victorian Heritage Register is amended by including the Heritage Register Number 1871 in the category described as a Heritage place:

The Delbridge House, 55 Carlsberg Road, Eaglemont, Banyule City Council.

EXTENT:

1. All the building known as former Delbridge House marked B1, the main drive path P1, the stone walls on Carlsberg Rd and their returns marked W1 & W2 on Diagram Number 607112 held by the Executive Director.
2. All the land marked L1 on Diagram Number 60 7112, held by the Executive Director being all the land described in Certificate of Title Vol 8184 Folio 174.

Dated: 3 March 2000.

RAY TONKIN
Executive Director



Heritage
VICTORIA

Heritage Act 1995

NOTICE OF REGISTRATION

As Executive Director for the purpose of the Heritage Act, I give notice under section 54(1) that the Victorian Heritage Register is amended by removing the former Victorian Heritage Register Number 69:

Burlington Terrace, 19 Lansdowne Street, East Melbourne, Melbourne City Council.

Dated: 3 March 2000.

RAY TONKIN
Executive Director



Heritage
VICTORIA

Heritage Act 1995

NOTICE OF REGISTRATION

As Executive Director for the purpose of the Heritage Act, I give notice under section 54(1) that the Victorian Heritage Register is amended by removing the former Victorian Heritage Register Number 70:

Burlington Terrace, 21 Lansdowne Street, East Melbourne, Melbourne City Council.

Dated: 3 March 2000.

RAY TONKIN
Executive Director



Heritage
VICTORIA

Heritage Act 1995

NOTICE OF REGISTRATION

As Executive Director for the purpose of the Heritage Act, I give notice under section 54(1) that the Victorian Heritage Register is amended by removing the former Victorian Heritage Register Number 73:

Burlington Terrace, 27 Lansdowne Street, East Melbourne, Melbourne City Council.

Dated: 3 March 2000.

RAY TONKIN
Executive Director



Heritage
VICTORIA

Heritage Act 1995

NOTICE OF REGISTRATION

As Executive Director for the purpose of the Heritage Act, I give notice under section 54(1) that the Victorian Heritage Register is amended by removing the former Victorian Heritage Register Number 71:

Burlington Terrace, 23 Lansdowne Street, East Melbourne. Melbourne City Council.

Dated: 3 March 2000.

RAY TONKIN
Executive Director



Heritage
VICTORIA

Heritage Act 1995

NOTICE OF REGISTRATION

As Executive Director for the purpose of the Heritage Act, I give notice under section 54(1) that the Victorian Heritage Register is amended by removing the former Victorian Heritage Register Number 72:

Burlington Terrace, 25 Lansdowne Street, East Melbourne, Melbourne City Council.

Dated: 3 March 2000.

RAY TONKIN
Executive Director

Planning and Environment Act 1987

GREATER GEELONG PLANNING SCHEME

Notice of Approval of Amendment

Amendment R251

The Minister for Planning has approved Amendment R251 to the Greater Geelong Planning Scheme.

The Amendment comes into operation on the date this notice is published in the Government Gazette.

The Amendment redesignates land comprising 2,100m² located at the north eastern corner of Shaws and Old Melbourne Roads, Little River and described as part of Certificate of Title Volume 3306 Folio 103 from Rural General Farming Zone to Public Purposes (Existing) No. 4 Reservation. The site's underlying zoning will be Rural General Farming Zone.

A copy of the Amendment can be inspected, free of charge, during office hours, at the Department of Infrastructure, Customer Service Centre, Upper Plaza, Nauru House, 80 Collins Street, Melbourne and at the offices of the Greater Geelong City Council, 2nd Floor, 103 Corio Street, Geelong.

PAUL JEROME
Executive Director
Planning, Heritage and
Building Division
Department of Infrastructure

Planning and Environment Act 1987
MORNINGTON PENINSULA PLANNING
SCHEME

Notice of Approval of Amendment

Amendment C14

The Minister for Planning has approved Amendment C14 to the Mornington Peninsula Planning Scheme.

The Amendment comes into operation on the date this notice is published in the Government Gazette.

The Amendment rezoned land at 1 Kent Street, Mornington, being Lot 20 on Plan of Subdivision No. 2889 from a Residential 1 Zone to a Business 5 Zone.

A copy of the Amendment can be inspected, free of charge, during office hours, at the Department of Infrastructure, Customer Service Centre, Upper Plaza, Nauru House, 80 Collins Street, Melbourne and at the offices of the Mornington Peninsula Shire Council, Mornington Office, Queen Street, Mornington; Hastings Office, Marine Parade, Hastings and Rosebud Office, Besgrove Street, Rosebud.

PAUL JEROME
Executive Director
Planning, Heritage and
Building Division
Department of Infrastructure

ORDERS IN COUNCIL

Estate Agents Act 1980

DECLARATION UNDER SECTION 61

The Governor in Council under section 61(2) of the **Estate Agents Act 1980** declares the Colonial State Bank to be an authorised financial institution for the purposes of section 60 of the **Estate Agents Act 1980**.

Dated 29 February 2000.

Responsible Minister:
MARSHA THOMSON
Minister for Consumer Affairs

HELEN DOYE
Clerk of the Executive Council

Land Act 1958

APPROVAL BY THE GOVERNOR IN
COUNCIL TO THE SALE OF CROWN
LAND BY PRIVATE TREATY

Order in Council

The Governor in Council, pursuant to Sections 99A(1)(a) & 99A(2) of the **Land Act 1958**, approves the sale by private treaty of the Crown land described below.

Property Address: Majorca Road, Talbot.

Crown Description: Allotment 15D, Section 1, Parish of Craigie.

Dated 7 March 2000.

Responsible Minister:
JOHN BRUMBY MP
Minister for Finance

HELEN DOYE
Clerk of the Executive Council

Land Act 1958

APPROVAL BY THE GOVERNOR IN
COUNCIL TO THE SALE OF CROWN
LAND BY PRIVATE TREATY

Order in Council

The Governor in Council, pursuant to sections 99A(1)(a) & 99A(2) of the **Land Act 1958**, approves the sale by private treaty of the Crown land described below.

Property Address: Barkstead North Road, Barkstead.

Crown Description: Allotment 11B, Township of Barkstead.

Dated 7 March 2000.

Responsible Minister:
JOHN BRUMBY MP
Minister for Finance

HELEN DOYE
Clerk of the Executive Council

Crown Land (Reserves) Act 1978

NOTICE OF INTENTION TO REVOKE
TEMPORARY RESERVATIONS

The Governor in Council under section 10 of the **Crown Land (Reserves) Act 1978**, gives notice of intention to revoke the following temporary reservations:

CUNNINGHAME — The temporary reservation by Order in Council of 22 November 1988 of an area of 49 square metres of land being Crown Allotment 62A, Township of Cunninghame, Parish of Colquhoun as a site for Sewerage Purposes. — (Rs 13983).

HAMILTON — The temporary reservation by Order in Council of 11 December 1944 of an area of 1821 square metres of land in the Township of Hamilton, Parish of Hamilton North (formerly Town of Hamilton, Parish of North Hamilton) as a site for a Children's Playground. — (Rs 5534).

HAMILTON — The temporary reservation by Order in Council of 13 January 1948 of an area of 76 square metres, more or less, of land in the Township of Hamilton, Parish of Hamilton North (formerly Town of Hamilton, Parish of North Hamilton) as a site for a Children's Playground in addition to and adjoining the site temporarily reserved therefor by Order in Council of 11 December 1944. — (Rs 5534).

KORKUPERRIMUL — The temporary reservation by Order in Council of 16 July 1873 of an area of 2.686 hectares of land being Crown Allotment 16, Section 16, Parish of Korkuperrimul as a site whence stone may be procured, revoked as to part by Order in Council of 19 May 1981 so far as the balance remaining containing 2.06 hectares. (Rs 4542).

MALDON — The temporary reservation by Order in Council of 24 January 1882 of an area

of 4351 square metres of land in Section L, Parish of Maldon as a site for affording access to Water as well as the withholding from sale, leasing or licensing and the excepting from occupation for mining purposes or for residence or business under any miner's right or business license by the same Order. — (06/17612).

MARYBOROUGH — The temporary reservation by Order in Council of 9 February 1993 of an area of 5972 square metres of land being Crown Allotments 26 and 27, Section 61, Township of Maryborough, Parish of Maryborough as a site for a Public park so far only as the portion containing 1988 square metres shown as Crown Allotment 26, Section 61, Township of Maryborough, Parish of Maryborough on Certified Plan No. 105508 lodged in the Central Plan Office. — (Rs 21034).

MYRTLEFORD — The temporary reservation by Order in Council of 10 October 1978 of an area of 2023 square metres of land being Crown Allotment 2G, Section 4, Parish of Myrtleford as a site for Public Recreation purposes. — (Rs 2243).

RODBOROUGH — The temporary reservation by Order in Council of 21 January 1878 of an area of 1.214 hectares, more or less, of land in Section 16A, Parish of Rodborough as a site for Watering purposes, as well as the withholding from sale, leasing or licensing and the excepting from occupation for mining purposes or for residence or business under any miner's right or business license by the same Order. — (06/15718).

WODONGA — The temporary reservation by Order in Council of 11 April 1962 of an area of 3010 square metres of land in Section O, Township of Wodonga, Parish of Wodonga as a site for Court House and Police Station, revoked as to part by Order in Council of 11 February 1964 so far as the balance remaining containing 2833 square metres. — (Rs 6632).

This Order is effective from the date on which it is published in the Government Gazette.

Dated 7 March 2000.

Responsible Minister:
SHERRYL GARBUTT

Minister for Environment and Conservation
HELEN DOYE
Clerk of the Executive Council

Crown Land (Reserves) Act 1978

NOTICE OF INTENTION TO REVOKE TEMPORARY RESERVATIONS

The Governor in Council under section 10 of the **Crown Land (Reserves) Act 1978**, gives notice of intention to revoke the following temporary reservations:

ARCHDALE — The temporary reservation by Order in Council of 13 September 1881 of an area of 2.023 hectares of land in the Parish of Archdale as a site for Public purposes (State school). — (2003964).

COHUNA — The temporary reservation by Order in Council of 24 February 1942 of an area of 18.21 hectares, more or less, of land in Section D, Parish of Cohuna as a site for Public Recreation, revoked as to part by Orders in Council of 25 September 1979 and 5 November 1997 so far only as the portions containing 3200 square metres, more or less, as indicated by hatching on plan hereunder. (C424[8]) — (Rs 5312).

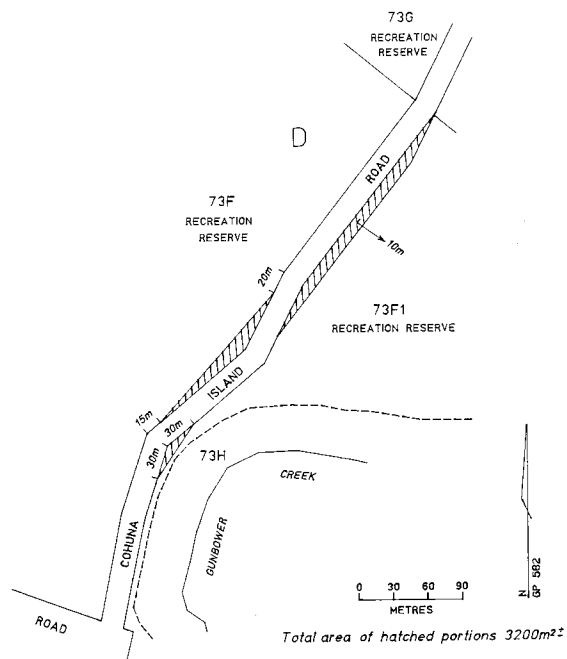

GUNBOWER — The temporary reservation by Order in Council of 7 January 1930 of an area of 6.475 hectares, more or less, of land in Section 5, Parish of Gunbower as a site for Public Recreation, so far only as the portion containing 3500 square metres, more or less, as indicated

by hatching on plan hereunder. (C199[18]) — (Rs 3937).

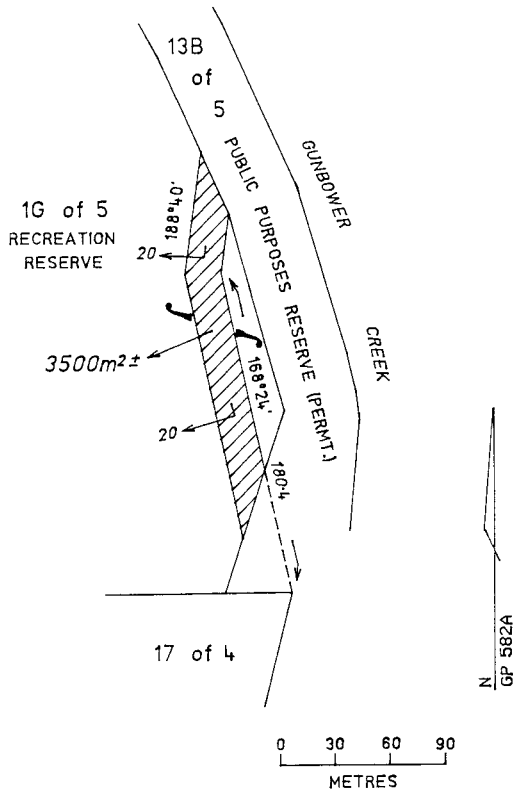

KATTYOONG — The temporary reservation by Order in Council of 2 February 1988 of an area of 7.259 hectares of land being Crown Allotment 1A, Parish of Kattoong as a site for Water Supply. — (Rs 13173).

WOMBAT — The temporary reservation by Order in Council of 5 June 1871 of an area of 4047 square metres of land in Section 4A, Parish of Wombat, (formerly portion of Crown Allotment 11A, Parish of Wombat [Leonard's Hill]) as a site for Common School purposes. — (05/12683).

This Order is effective from the date on which it is published in the Government Gazette.

Dated 7 March 2000.

Responsible Minister:
SHERRYL GARBUTT
 Minister for Environment and Conservation
HELEN DOYE
 Clerk of the Executive Council

Crown Land (Reserves) Act 1978
 TEMPORARY RESERVATION OF
 CROWN LANDS

The Governor in Council under section 4(1) of the **Crown Land (Reserves) Act 1978** temporarily reserves the following Crown lands which in his opinion are required for the purposes mentioned:-

**MUNICIPAL DISTRICT OF THE
 BALLARAT CITY COUNCIL**

BALLARAT — Hospital purposes, 1500 square metres, more or less, being Crown Allotment 1A, Section 39, Township of Ballarat, Parish of Ballarat as indicated by hatching on plan hereunder. (B128[65]) — (Rs 11405).

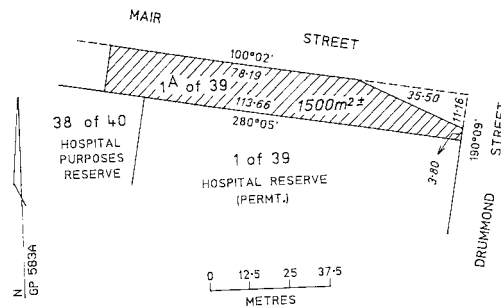

**MUNICIPAL DISTRICT OF THE
 INDIGO SHIRE COUNCIL**

CHILTERN — Community Use (Museum), 360 square metres, more or less, being Crown Allotment 1C, Section J, Township of Chiltern, Parish of Chiltern as indicated by hatching on plan hereunder. (C225[9]) — (Rs 6200).

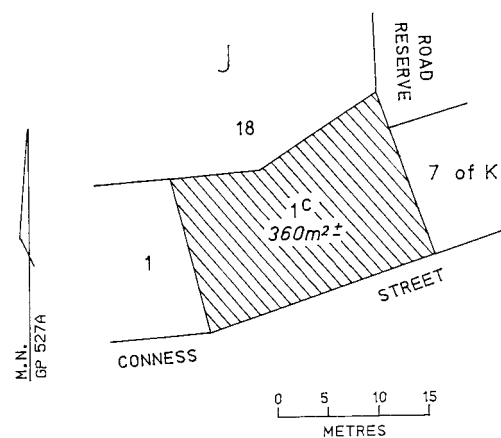

MUNICIPAL DISTRICT OF THE
GREATER BENDIGO CITY COUNCIL

MANDURANG and SANDHURST — Water Supply purposes, 120 hectares, more or less, being the lands in the Parishes of Mandurang and Sandhurst shown by red hatching on plan LEGL./98-15 lodged in the Central Plan Office. — (Rs 12274).

MUNICIPAL DISTRICT OF THE
MILDURA RURAL CITY COUNCIL

MILDURA — State Public Offices, 930 square metres being Crown Allotment 77A, Section D, Parish of Mildura as indicated by hatching on plan hereunder. (M533[2]) — (Rs 11455).

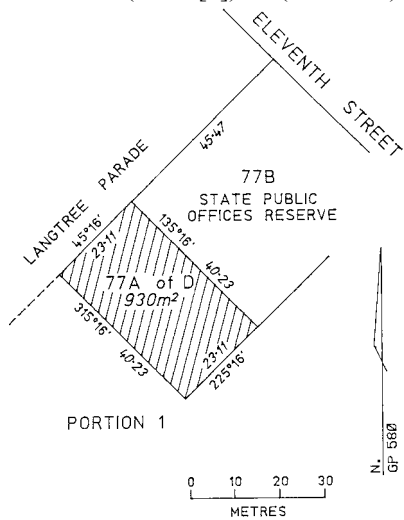

MUNICIPAL DISTRICT OF THE
ARARAT RURAL CITY COUNCIL

MOYSTON — Public purposes, 97 square metres, more or less, being Crown Allotment 159B, No Section, Township of Moyston, Parish of Moyston as indicated by hatching on plan hereunder. (M299[4]) — (05/2006365).

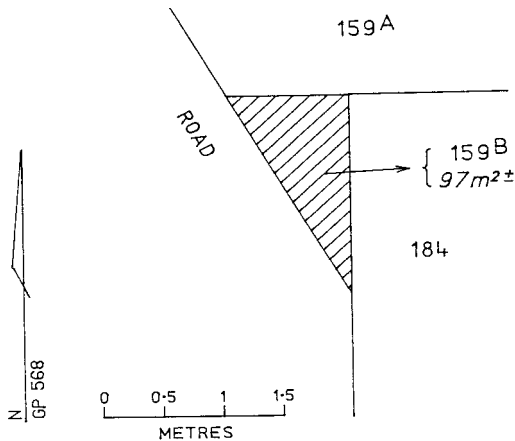

MUNICIPAL DISTRICT OF THE
ARARAT RURAL CITY COUNCIL

MOYSTON — Conservation of an area of natural and historic interest, 24 hectares, more or less, being Crown Allotment 8, Section 11 and Crown Allotment 7, Section 13, Township of Moyston, Parish of Moyston as indicated by hatching on plan hereunder. (M299[4]) — (Rs 465).

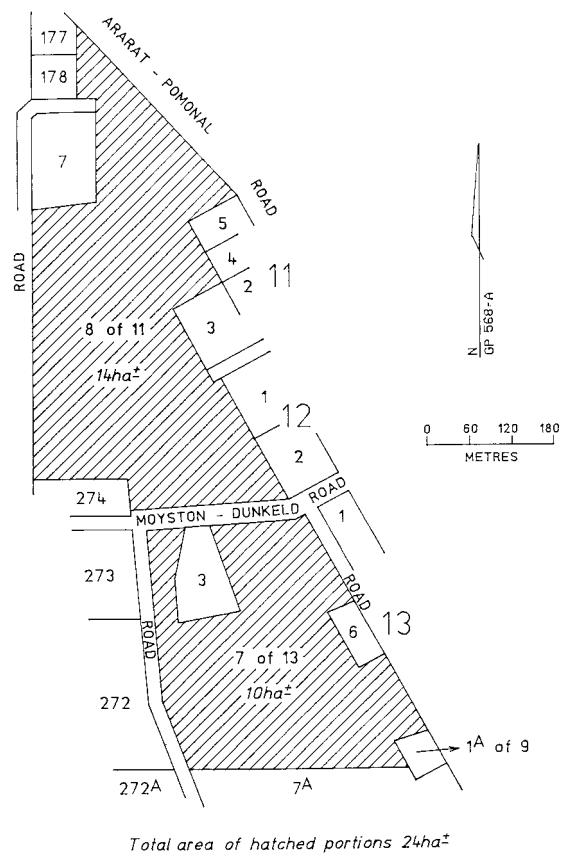

MUNICIPAL DISTRICT OF THE
BASS COAST SHIRE COUNCIL

PHILLIP ISLAND — Conservation of an area of natural interest, 82.43 hectares being Crown Allotment 110B, parish of Phillip Island as indicated by hatching on plan hereunder. (P136[4]) — (Rs 7714).

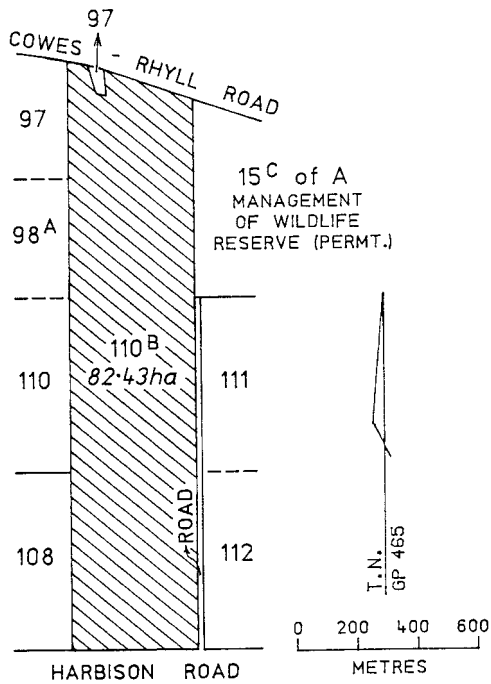

MUNICIPAL DISTRICT OF THE
CASEY CITY COUNCIL

SHERWOOD — Public purposes, 2708 square metres being Crown Allotment 17A, Section 1A, Parish of Sherwood as indicated by hatching on plan hereunder. (S271[6]) — (Rs 3627).

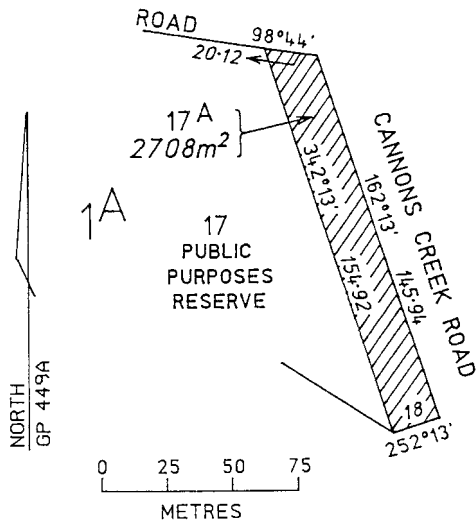

MUNICIPAL DISTRICT OF THE
WANGARATTA RURAL CITY COUNCIL
WANGARATTA SOUTH — Public purposes

(Cemetery purposes) 7.397 hectares being Crown Allotment 9D, Section 31, Parish of Wangaratta South as indicated by hatching on plan hereunder. (W85[9]) — (Rs 1108806).

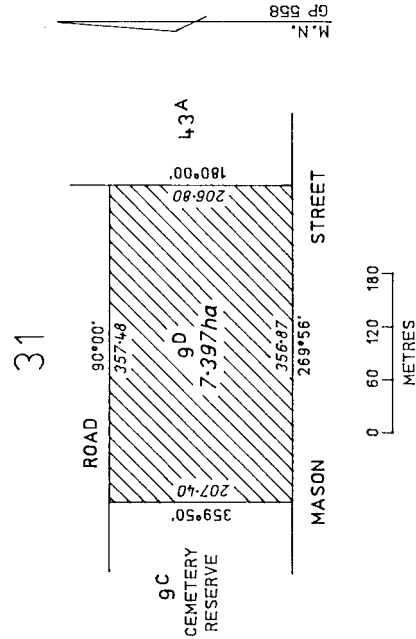

MUNICIPAL DISTRICT OF THE
WELLINGTON SHIRE COUNCIL

YARRAM YARRAM — Police purposes, 859 square metres, being Crown Allotment 51B, Parish of Yarram Yarram as indicated by hatching on plan hereunder. (Y50[3]) — (15/L10-6766).

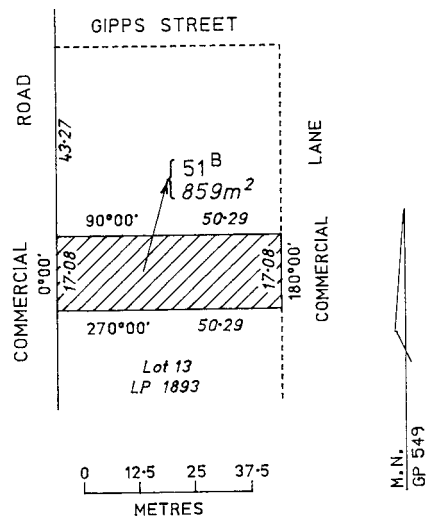

This Order is effective from the date on which it is published in the Government Gazette.

Dated 7 March 2000.

Responsible Minister:
SHERRYL GARBUTT
 Minister for Environment and Conservation
HELEN DOYE
 Clerk of the Executive Council

Land Act 1958

CLOSURE OF UNUSED ROADS

The Governor in Council under section 349 of the **Land Act 1958** and with the concurrence in writing of the municipalities in which the roads are situated closes the following unused roads:

MUNICIPAL DISTRICT OF THE CASEY CITY COUNCIL

SHERWOOD — The road in the Parish of Sherwood as indicated by hatching on plan hereunder. (S271[6]) — (Rs 3627).

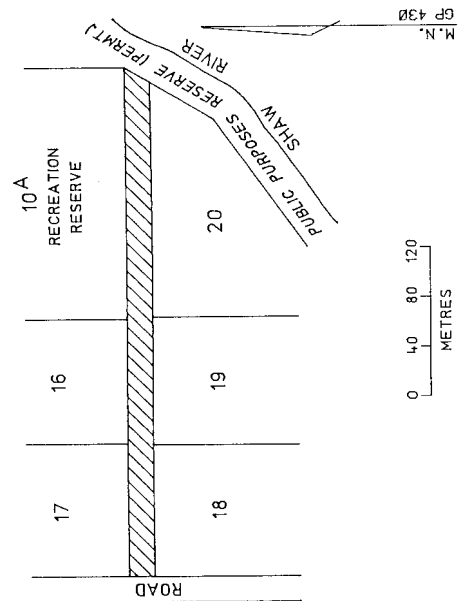

This Order is effective from the date on which it is published in the Government Gazette.

Dated 7 March 2000.

Responsible Minister:
SHERRYL GARBUTT
 Minister for Environment and Conservation
HELEN DOYE
 Clerk of the Executive Council

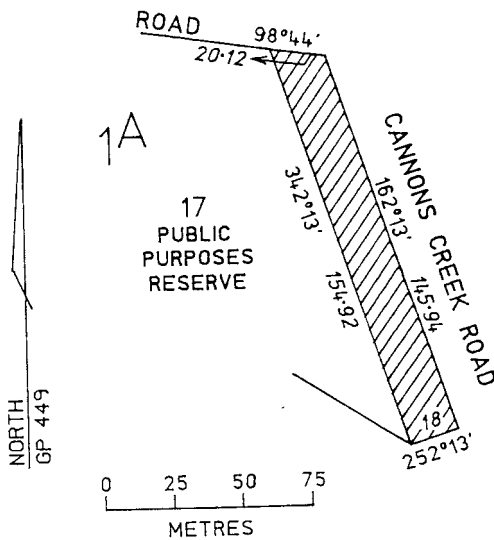

MUNICIPAL DISTRICT OF THE MOYNE SHIRE COUNCIL

YAMBUK — The road in the Township of Yambuk, Parish of Codrington as indicated by hatching on plan hereunder. (Y39[4]) — (03/05672).

Land Act 1958

CLOSURE OF UNUSED ROADS

The Governor in Council under section 349 of the **Land Act 1958** and with the concurrence in writing of the municipalities in which the roads are situated and the owners of land adjoining those roads closes the following unused roads:

MUNICIPAL DISTRICT OF THE MITCHELL SHIRE COUNCIL

BAYNTON — The road in the Parish of Baynton shown as Crown Allotment 23A, Section 2 on Original Plan No. 120233 lodged in the Central Plan Office. — (06/L1-4291).

MUNICIPAL DISTRICT OF THE TOWONG SHIRE COUNCIL

BETHANGA — The road in the Township of Bethanga, Parish of Berringa as indicated by hatching on plan hereunder. (B691[3]) — (L8-5863).

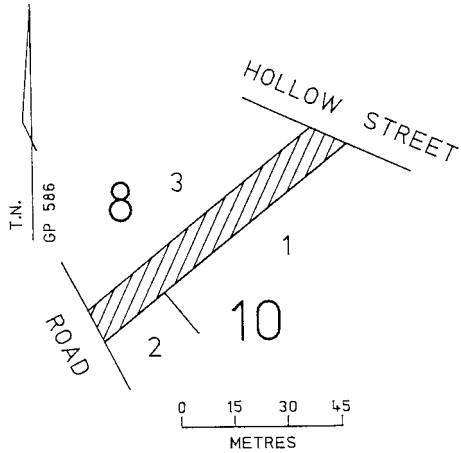

MUNICIPAL DISTRICT OF THE
INDIGO SHIRE COUNCIL
CHILTERN WEST — The road in the Parish of Chiltern West as indicated by hatching on plan hereunder. (2382) — (P203340).

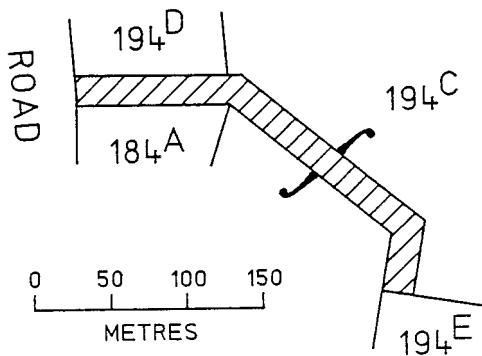

MUNICIPAL DISTRICT OF THE
GOLDEN PLAINS SHIRE COUNCIL
DEREEL — The road in the Parish of Dereel as indicated by hatching on plan hereunder. (D172[7]) — (05/09719).

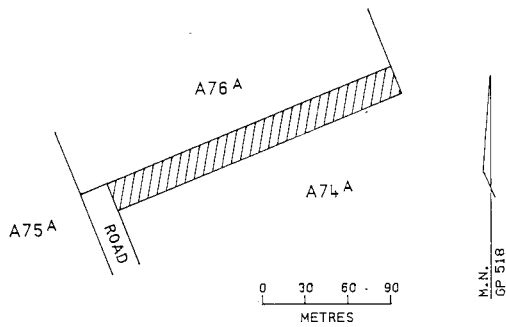

MUNICIPAL DISTRICT OF THE
MOUNT ALEXANDER SHIRE COUNCIL
DRUMMOND — The road in the Parish of Drummond as indicated by hatching on plan hereunder. (D169[2]) — (06/P121953).

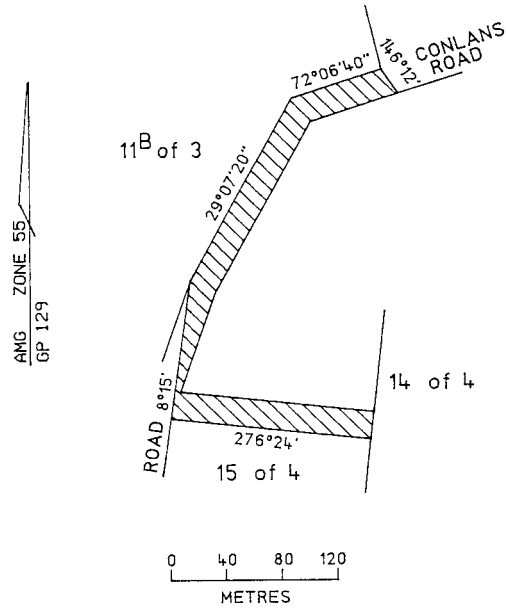

MUNICIPAL DISTRICT OF THE
GREATER BENDIGO CITY COUNCIL
EPPALOCK — The road in the Parish of Eppalock as indicated by hatching on plan hereunder. (E54[2]) — (06/P120666).

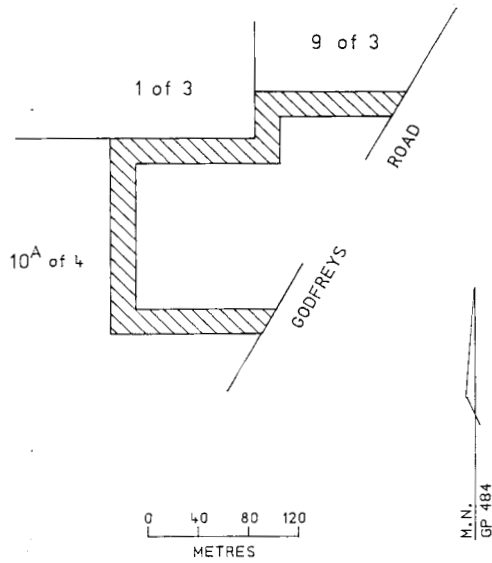

MUNICIPAL DISTRICT OF THE
MORNINGTON PENINSULA SHIRE
COUNCIL

KANGERONG — The road in the Parish of Kangerong as indicated by hatching on plan hereunder. (K7[4]) — (12/P241398).

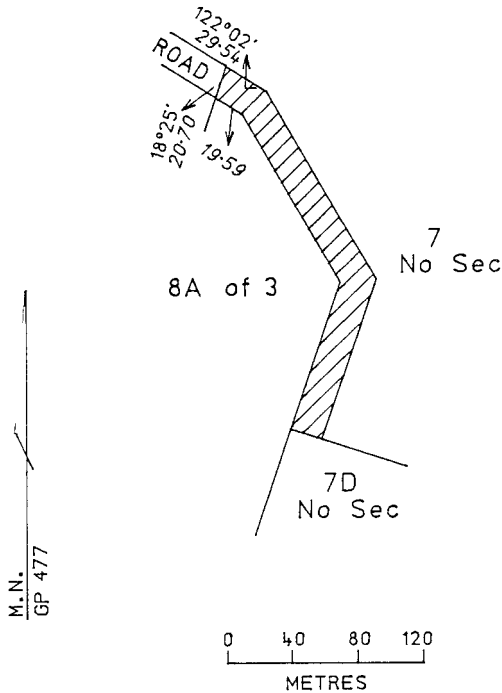

MUNICIPAL DISTRICT OF THE
NORTHERN GRAMPIANS SHIRE
COUNCIL

SWANWATER — The road in the Parish of Swanwater as indicated by hatching on plan hereunder. (S367[7]) — (06/P124191).

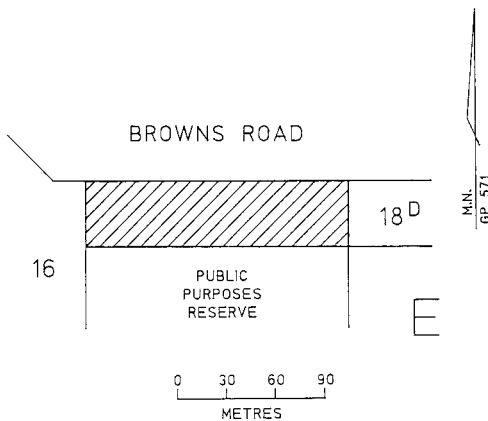

MUNICIPAL DISTRICT OF THE
TOWONG SHIRE COUNCIL

TINTALDRA — The road in the Parish of Tintaldra shown as Crown Allotment 8C, Section 6 on Original Plan No. 119906 lodged in the Central Plan Office. — (L8-6317).

MUNICIPAL DISTRICT OF THE
BASS COAST SHIRE COUNCIL

WONTHAGGI — The roads in the Township of Wonthaggi, Parish of Wonthaggi as indicated by hatching on plan hereunder. (W345[16]) — (DTF 97/02874).

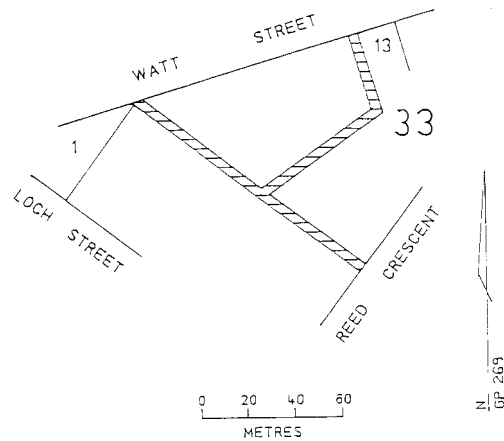

This Order is effective from the date on which it is published in the Government Gazette.

Dated 7 March 2000.

Responsible Minister:
SHERRYL GARBUTT
Minister for Environment and Conservation
HELEN DOYE
Clerk of the Executive Council

Crown Land (Reserves) Act 1978
INCORPORATION OF COMMITTEE OF
MANAGEMENT OF THE MEENIYAN
MECHANICS INSTITUTE RESERVE

The Governor in Council under section 14A(1) of the **Crown Land (Reserves) Act 1978**, being satisfied that it is in the public interest to declare to be a corporation the Committee of Management appointed under section 14(2) of the Act of the land described in the schedule hereunder:-

- (a) declares that the Committee of Management shall be a corporation;

(b) assigns the name “MEENIYAN MECHANICS INSTITUTE INCORPORATED” to the corporation; and

under section 14B(3) of the Act, appoints Mick HANILY to be Chairperson of the corporation.

SCHEDULE

The land in the Township of Meeniyah, Parish of Nerrena being Crown Allotment 11, Section 4, temporarily reserved as a site for a Mechanics’ Institute by Order in Council of 8 August 1892 and published in the Government Gazette on 12 August 1892 – page 3282. — Rs 4944.

This Order is effective from the date on which it is published in the Government Gazette.

Dated 7 March 2000.

Responsible Minister:
SHERRYL GARBUTT
Minister for Environment and Conservation
HELEN DOYE
Clerk of the Executive Council

VICTORIA

State Aid to Religion Abolition Act 1871

ACT NO. 391/1871 — SECOND SCHEDULE

A statement of trusts having been submitted by the head or authorised representative of the Uniting Church in Australia under the provisions of the “Act to provide for the abolition of State Aid to Religion” for allowance by the Governor in Council, the same was allowed by him on the Seventh day of March, 2000 and the following is the form in which such statement of trusts has been allowed.

STATEMENT OF TRUSTS

DESCRIPTION OF LAND:-

Site for Presbyterian Place of Public Worship and Minister’s Dwelling temporarily reserved by Order in Council of 22 May 1871 revoked as to part by Order in Council of 1 July 1952 being 5943 square metres, Parish of Shelford West, County of Grenville being Crown Allotment 46B.

Commencing on the Rokewood-Shelford Road at the north-eastern angle of the site being

a point bearing 297° 21’ 42.95 metres from the most north-eastern angle of allotment 46A, bounded thence by Allotment 46A bearing 187° 15’ 143.43 metres; bearing 277° 15’ 40.23 metres, bearing 7° 15’ 151.68 metres, and thence by the Rokewood-Shelford Road bearing 108° 28’ 39.35 metres and bearing 117° 21’ 1.75 metres to the point of commencement.

NAME OF TRUSTEES:-

The Uniting Church in Australia Property Trust (Victoria).

POWERS OF DISPOSITION:-

Such powers of disposition including powers of sale, lease or mortgage as are given to the Trustees by the **Uniting Church in Australia Act No. 9021 of 1977** as amended.

PURPOSES TOWARDS WHICH PROCEEDS OF DISPOSITION ARE TO BE APPLIED:-

To such Uniting Church in Australia purposes as shall be approved by the Synod of Victoria of the Uniting Church in Australia.

This Order is effective from the date on which it is published in the Government Gazette.

Dated 7 March 2000.

Responsible Minister:
SHERRYL GARBUTT
Minister for Environment and Conservation
HELEN DOYE
Clerk of the Executive Council

Forests Act 1958

EXCHANGE OF RESERVED FOREST FOR CROWN LAND

The Governor in Council under section 49(1) of the **Forests Act 1958** authorises, in exchange for the Crown land described in the Dedication Schedule hereunder, the excision of the lands described in the Excision Schedule hereunder from reserved forest.

DEDICATION SCHEDULE

An area of 8900 square metres, more or less, of Crown land being Allotment 82E in the Parish of Kialla as indicated by hatching on plan hereunder. (K135[5]) — (P161565).

Dated 7 March 2000.

Responsible Minister:
 SHERRYL GARBUTT
 Minister for Environment and Conservation

HELEN DOYE
 Clerk of the Executive Council

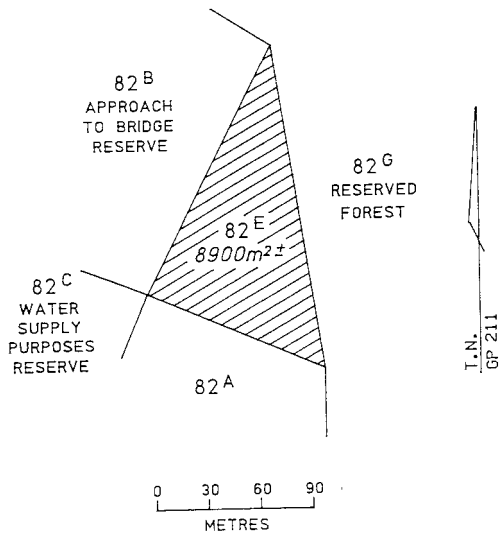

An area of 4082 square metres, more or less, of Crown land being Allotment 14D of Section 2 in the Parish of Whitfield South as indicated by hatching on plan hereunder. (W317[6]) — (L8/4354).

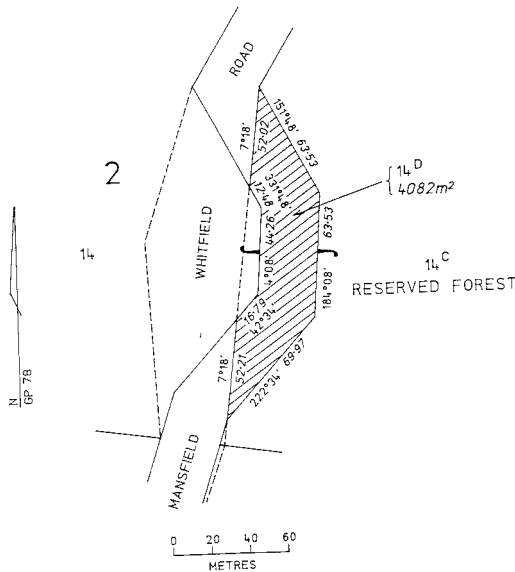

EXCISION SCHEDULE

An area of 1.4 hectares, more or less, of reserved forest being Allotment 89G in the Parish of Ellesmere as shown on Certified Plan 120208 lodged in the Central Plan Office. — (L6-10443).

Such excisions and dedication to come into effect on the fourteenth day after publication of this Order in the Victoria Government Gazette.

LATE NOTICES

Crown Land (Reserves) Act 1978ORDER GIVING APPROVAL TO GRANT
OF LEASE

Pursuant to sections 17D(1) and 17DA of the **Crown Land (Reserves) Act 1978** I, Sherryl Garbutt, Minister for Environment and Conservation, being satisfied that there are special reasons which make granting a lease reasonable and appropriate in the particular circumstances and to do this will not be substantially detrimental to the use and enjoyment of any adjacent land reserved under the **Crown Land (Reserves) Act 1978**, approve the granting of a lease by the City of Melbourne over parts of Yarra Park described and identified in the Schedule below for the purpose of providing areas for the support services and facilities required to facilitate the staging of the Olympic Football Tournament at the Melbourne Cricket Ground and without limiting the generality of such purpose includes provision of a broadcasting compound and associated cables to the Melbourne Cricket Ground Reserve, vehicle permit and security check points, portable ticket boxes, soil and turf storage compounds and carparking areas, and, in accordance with section 17D3(a) of the **Crown Land (Reserves) Act 1978**, state that:-

- a) there are special reasons which make granting the lease reasonable and appropriate in the particular circumstances; and
- b) to do this will not be substantially detrimental to the use and enjoyment of any adjacent land reserved under the **Crown Land (Reserves) Act 1978**.

In stating the above, I also confirm that my approval, taking into the requirements of section 17D(3)(a) of the **Crown Land (Reserves) Act 1978**, will also apply to any additional parts of Yarra Park that may be required at short notice to facilitate the staging of the Olympic Football Tournament at the Melbourne Cricket Ground arising out of changed requirements of the Sydney Organising Committee for the Olympic Games, changed surface conditions of Yarra Park or to accommodate changed security measures.

SCHEDULE

The areas shown shaded on the following plan and identified as Broadcast Compound, Broadcasters/Media Parking, Operations External parking Vehicle Check Point, Vehicle Permit Check, Ticketing Office, cable route sand stockpile and soil stockpile, being parts of the land permanently reserved as a public park by Order in Council dated 9 June 1973 and published in the Government Gazette of 13 June 1973. The above areas are approximate only at this stage and may change subject to any emerging requirements of the Sydney Organizing Committee for the Olympic Games. — Rs 4134.

LEGEND

Gazetal Plan

- OPERATIONS PARKING (4th SEPTEMBER - 6th OCTOBER)
- MEDIA AND BROADCASTING OVERFLOW PARKING (13th-29th SEPTEMBER DURING GAMES ONLY)
- SOBO COMPOUND (14th JULY - 6th OCTOBER) (PARKING 4th SEPTEMBER - 6th OCTOBER)
- TICKETING OFFICE 6x3m
- LOGISTIC AND VIP VEHICLE ROUTES
- TRUCK ROUTE
- M.C.S. OVAL WORKS (4th SEPT' - 6th SEPT')
- VEHICLE PERMIT CHECK POINT (VPEC)
- VEHICLE CHECK POINT (VCP)
- CABLE ROUTE
- 100m BUFFER

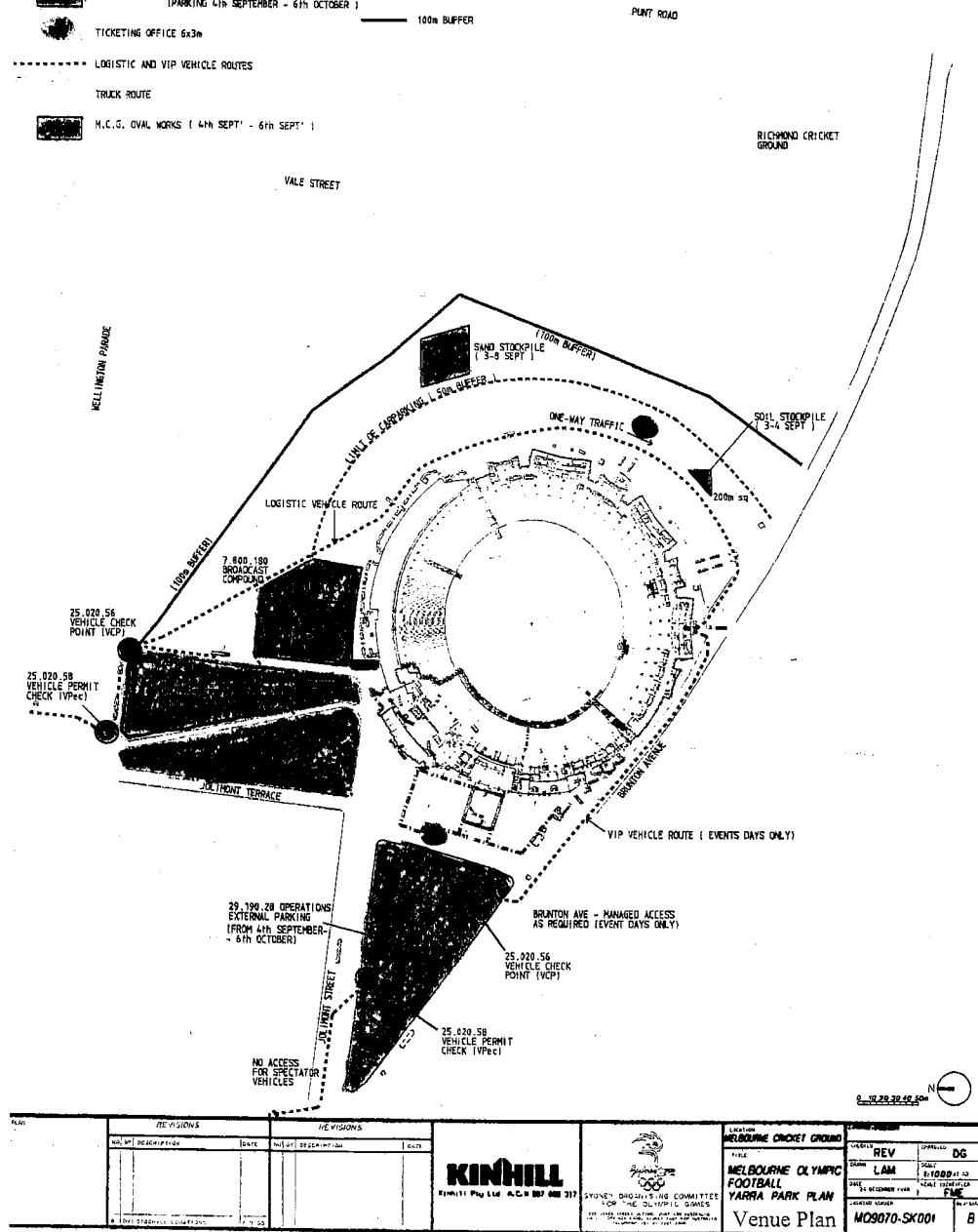

REV	DESCRIPTION	DATE	BY	CHKD

 KinHill Pty Ltd A.C.N. 807 488 217	 SYDNEY ORGANISING COMMITTEE FOR THE OLYMPIC GAMES	LOCATION: MELBOURNE CRICKET GROUND
		PROJECT: MELBOURNE OLYMPIC FOOTBALL YARRA PARK PLAN
DRAWN BY: LAM	CHECKED BY: LAM	DATE: 26 DECEMBER 1999
SCALE: 1:1000	TITLE: VENUE PLAN	PROJECT NO: M09070-SK001

Dated 8 March 2000.

SHERRYL GARBUTT MP
Minister for Environment and Conservation

**SUBORDINATE LEGISLATION ACT 1994
NOTICE OF MAKING OF STATUTORY
RULES**

Notice is hereby given under Section 17 (2) of the **Subordinate Legislation Act 1994** of the making of the following Statutory Rules:

12. *Statutory Rule:* Subordinate Legislation (Environment Protection (Purchase and Sale of Products Containing Ozone-depleting Substances) Regulations 1990 — Extension of Operation) Regulations 2000
- Authorising Act:* Subordinate Legislation Act 1994
- Date of making:* 7 March 2000
13. *Statutory Rule:* Marine (Amendment) Regulations 2000
- Authorising Act:* Marine Act 1988
- Date of making:* 7 March 2000

**SUBORDINATE LEGISLATION ACT 1994
NOTICE THAT STATUTORY RULES ARE
OBTAINABLE**

Notice is hereby given under Section 17 (3) of the **Subordinate Legislation Act 1994** that the following Statutory Rules were first obtainable from Information Victoria, 356 Collins Street, Melbourne on the date specified:

11. *Statutory Rule:* Conservation, Forests and Lands (Contracts) Regulations 2000
- Authorising Act:* Conservation, Forests and Lands Act 1987
- Date first obtainable:* 9 March 2000
- Code A*

Retail price will vary according to the number of pages in each special or periodical gazette. The table below sets out the prices that apply

<i>Price Code</i>	<i>No. of Pages (Including cover and blank pages)</i>	<i>Price</i>
A	1-16	\$2.90
B	17-32	\$4.30
C	33-48	\$5.90
D	49-96	\$9.15
E	97-144	\$11.85
F	145-192	\$14.00
G	193-240	\$16.15
H	241-288	\$17.20
I	289-352	\$19.35
J	353-416	\$22.60
K	417-480	\$25.80
L	481-544	\$30.10
M	545-608	\$34.40
N	609-672	\$38.70
O	673-736	\$43.00
P	737-800	\$47.30

ADVERTISERS PLEASE NOTE

As from 9 March 2000

The last Special Gazette was No. 27
dated 8 March 2000

The last Periodical Gazette was No. 2
dated 28 October 1999

CONTENTS

	Page
Estates of Deceased Persons	416
Government and Outer Budget Sector	
Agencies Notices	425
Orders in Council—	450
Acts — Estate Agents; Land; Crown Land (Reserves); State Aid to Religion Abolition; Forests	
Private Advertisements	416
Proclamations	423

The Victoria Government Gazette is published by The Craftsman Press Pty. Ltd. with the authority of the Government Printer for the State of Victoria
© State of Victoria 2000

ISSN 0819-5471

This publication is copyright. No parts may be reproduced by any process except in accordance with the provisions of the Copyright Act.

Products and services advertised in this publication are not endorsed by The Craftsman Press Pty. Ltd. or the State of Victoria and neither of them accepts any responsibility for the content or the quality of reproduction. The Craftsman Press Pty. Ltd. reserves the right to reject any advertising material it considers unsuitable for government publication.

Address all enquiries to the Government Printer for the State of Victoria
Government Information and Communications Branch
Department of Premier and Cabinet
Level 3, 356 Collins Street
Melbourne 3000
Victoria Australia

RETAIL SALES

Information Victoria Bookshop
356 Collins Street Melbourne 3000.
Telephone enquiries 1300 366 356

City Graphics
Level 1, 520 Bourke Street
Melbourne 3000
Telephone enquiries (03) 9600 0977

Recommended Retail Price \$1.70

Government and Outer Budget Sector Agencies please note:
STYLE REQUIREMENTS.

To ensure that material received can be reproduced, and that errors are minimised, the following guidelines are to be observed when submitting material by fax.

Fax resolution:

Material sent by fax should be transmitted using Fine Resolution (200 dots per inch by 200 dpi).

Font size:

Use 12 point (10 pitch) or larger.

Font Style:

Clear plain font styles, such as Helvetica, should be used.

Graphics:

Line drawings should be transmitted as large as possible to ensure clarity. Drawings up to A4 size sent by fax using Fine Resolution provide a good quality for reproduction.

Avoid:

Italics, underlining and full justification.

Ensure document is square when sending as documents that are sent skewed are difficult to read and process.