



Victoria Government Gazette

No. G 15 Thursday 13 April 2000

GENERAL

GENERAL AND PERIODICAL GAZETTE

Copy to: Gazette Officer
The Craftsman Press Pty. Ltd.
125 Highbury Road,
Burwood Vic 3125
Telephone: (03) 9926 1233
Facsimile: (03) 9926 1292
DX: 32510 Burwood
Email: gazette@craftpress.com.au

Advertising Rates and Payment

Private Notices

Payment must be received in advance with advertisement details.

30 cents per word - Full page \$180.00.

Additional costs must be included in prepayment if a copy of the gazette is required. Copy Prices - Page

\$1.50 - Gazette \$3.20 Certified copy of Gazette \$3.50. (all prices include Postage). **Cheques should be made payable to The Craftsman Press Pty. Ltd.**

Government and Outer Budget Sector Agencies Notices

Not required to pre-pay.

Advertisements may be faxed or sent via email with a cover sheet, marked to the attention of the Gazette Officer.

Floppy Disks (Mac & PC) can also be accepted.

Costs can be calculated on the following basis:

Per Line	Typeset
Single column	\$1.55
Double column	\$3.10
Full Page	\$64.80

The Craftsman Press is pleased to offer a series of discounts from the typesetting costs.

1. Copy supplied on disk.
2. Copy supplied via email.
3. Artwork for forms and other material which require exact reproduction.

1. Copy supplied on disk.

Where a disk is supplied and there is minimum alteration required, **30% off.**

Where a disk is supplied requiring extraneous matter stripped out and styles applied, **20% off.**

2. Copy supplied via email.

Where a notice is sent via email and there is minimum alteration required, **25% off.**

Where email is supplied requiring extraneous matter stripped out and styles applied, **15% off.**

3. Artwork for forms and other material which requires exact reproduction.

Scanning and sizing of artwork for forms, to be reproduced in page format, **35% off.**

Copy Deadline for General Gazette

9.30 a.m. Monday - (Private Notices)

9.30 a.m. Tuesday - (Government and Outer Budget Sector Agencies Notices)

Advertisers should note:

- Late copy received at The Craftsman Press Pty. Ltd. after deadlines will be placed in the following issue of VGG, irrespective of any date/s mentioned in the copy (unless otherwise advised).
- Proofs will be supplied only when requested or at the direction of the Gazette Officer.
- No additions or amendments to material for publications will be accepted by telephone.
- Orders in Council may be lodged prior to receiving assent with the Governor's or Clerk's signature. They will only be published once approved and signed.
- Government and Outer Budget Sector Agencies please note: *See style requirements on back page.*

SPECIAL GAZETTES

Copy to: Gazette Officer
The Craftsman Press Pty. Ltd.
125 Highbury Road,
Burwood Vic 3125
Telephone: (03) 9926 1233
Facsimile: (03) 9926 1292
Email: gazette@craftpress.com.au

Advertising Rates and Payment

Private Notices

Full Page \$360.00

Payment must be received in advance with notice details.

Government and Outer Budget Sector Agencies Notices

	Typeset
Full Page	\$87.50

Note:

The after hours number for Special Gazettes is:
Telephone: 0419 327 321

SUBSCRIPTIONS AND RETAIL SALES

Copies of the Victoria Government Gazette can be purchased from The Craftsman Press Pty. Ltd. by subscription.

The Victoria Government Gazette

General and Special - \$170.00 each year

General, Special and Periodical - \$227.00 each year

Periodical - \$113.00 each year

Subscriptions are payable in advance and accepted for a period of one year. All subscriptions are on a firm basis and refunds will not be given.

All payments should be made payable to The Craftsman Press Pty. Ltd.

Subscription enquiries:

The Craftsman Press Pty. Ltd.
125 Highbury Road, Burwood Vic 3125
Telephone: (03) 9926 1233

INDEX TO PRIVATE ADVERTISERS

A

Andrew McMullan & Co680
Aitken Walker & Strachan680
Arthur J. Dines & Co681

C

Chessell Williams681
-------------------------	------

G

Garden & Green681
Gargan & Roache681
Goldsmiths681

H

Hanlons681
---------------	------

K

Kelly & Chapman681
-----------------------	------

L

Lorraine Jones & Associates682
-----------------------------------	------

M

Macpherson & Kelly682
Mason Sier Turnbull682
Mills Oakley682

O

Oakley Thompson & Co682
----------------------------	------

P

Perpetual Trustees Victoria Limited683
Peter J. Walsh Carroll Kiernan & Forrest683

R

Rennick & Gaynor683
------------------------	------

S

S. C. McCarthy & Co. Pty683
--------------------------------	------

T

T. J. Mulvaney & Co.683
Tolhurst Druce & Emmerson683

W

William Murray683
----------------------	------

**PUBLICATION OF THE
VICTORIA GOVERNMENT
GAZETTE (GENERAL)
EASTER PUBLIC HOLIDAYS**

PLEASE NOTE:

The Victoria Government Gazette for the Easter week will be published on Thursday 27 April 2000. All copy for all advertisements must reach the Government Gazette Office by 9.30 a.m. on Wednesday 19 April 2000.

Where urgent gazettal is required after hours, arrangements should be made with Ann White on 0419 327 321.

ANN WHITE
Government Gazette Officer

PRIVATE ADVERTISEMENTS

Land Act 1958

Notice is hereby given that the Yarra Pistol Club Inc. (A.C.N. 004 635 545) has applied for a lease pursuant to Section 134 of the **Land Act 1958** for a term of 21 years in respect of Crown land Allotment 49A, in the Parish of Narree Worran as shown on CP 104839 for the purposes of amusement, recreation and social activities connected therewith.

PARTNERSHIP NOTICE

Ronald George Laird joined the Melbourne Partnership of Gadens Lawyers on 4 April 2000.
GADENS LAWYERS.

DISSOLUTION OF PARTNERSHIP

Notice is hereby given that the partnership heretofore subsisting between Mei Wong of 3/22 Langford Street, Surrey Hills and Grantley Peck of same address, carrying on business as Austaiwan Trade Link, has been dissolved as from 1 July 1999.

DISSOLUTION OF PARTNERSHIP

Notice is hereby given that the partnership previously subsisting between us the undersigned, Catering Carts Pty Ltd, A.C.N. 068 254 982 of 22 Hickford Parade, Warrnambool and Kathryn Mary Chiller of 25 Collins Street, Hamilton, trading as Catering Carts Pty Ltd., at 22 Hickford Parade, Warrnambool, carrying on the business of outdoor catering, has been dissolved.

The business in the future shall be conducted by Kathryn Mary Chiller and Peter Stanley Chiller.

Dated 1 July 1999.

CATERING CARTS PTY LTD
A.C.N. 068 254 982

KATHRYN MARY CHILLER

Creditors, next-of-kin and others having claims in respect of the estate of ADA CHRISTINA DELORA, late of 29 Baker Street, North Richmond, in the State of Victoria, widow, who died on 27 March 2000, are required to send particulars of their claim to Andrew McMullan & Co. Legal Practitioners,

64 Kingsway, Glen Waverley, in the said State, legal practitioners for the executors of the said estate, by 30 June 2000 after which time the appointed executors will distribute the assets having regard only to claims of which they then have notice.

ANDREW McMULLAN & CO.,
legal practitioners,
64 Kingsway, Glen Waverley, Victoria.

NORA LILIAN CUMMING, late of Sir Donald and Lady Trescowthick Centre, 70 Charles Street, Prahran, widow, deceased. Creditors, next-of-kin and others having claims in respect of the estate of the deceased, who died on 18 February 2000, are required by the personal representative, Equity Trustees Limited of 472 Bourke Street, Melbourne, to send particulars to them care of the undermentioned solicitors by 21 June 2000 after which date the personal representatives may convey or distribute the assets having regard only to the claims of which they then have notice.

AITKEN WALKER & STRACHAN,
solicitors,
114 William Street, Melbourne 3000.

Creditors, next-of-kin and others having claims in respect of the estate of LLOYD STANLEY REES, late of Flat 10, K3 High Street, Windsor, in the State of Victoria, salesman, who died on 12 October 1999, are required to send particulars of their claim to Andrew McMullan & Co. Legal Practitioner, 64 Kingsway, Glen Waverley, in the said State, solicitors for the executrix of the said estate by 30 June 2000 after which date the appointed executrix will distribute the assets having regard only to the claims of which she then has notice.

ANDREW McMULLAN & CO.,
legal practitioner,
64 Kingsway Glen Waverley, Victoria.

MYRTLE SYBIL ROLLINSON, late of Glenhuntly Nursing Home, 5 Maroona Road, Glenhuntly, gentlewoman, deceased. Creditors, next-of-kin and others having claims in respect of the estate of the deceased, who died on 3 February 2000, are required by the personal

representative, Edna Smith of 1225 Malvern Road, Malvern, to send particulars to her care of the undermentioned solicitors by 21 June 2000 after which date the personal representative may convey or distribute the assets having regard only to the claims of which she then has notice.

AITKEN WALKER & STRACHAN,
solicitors,
114 William Street, Melbourne 3000.

Take notice that Roda Veliou of 61 Duncan Road, Lalor, in the State of Victoria, home duties and Ellen Vitis (formerly Phillips) of 6 Donbinn Way, Vermont South in the said State, receptionist and Mary MacFarlane (formerly Phillips) of 30 The Avenue, East Malvern, in the said State, offices administrators, the executrices named in the will dated 16 January 1973 of JIM PHILLIPS, also known as James Phillips, deceased, late of 343 Edgars Road, Lalor, in the said State, pensioner, will 14 days after the date of publication of this advertisement, apply to the Supreme Court of Victoria for a grant of probate of that will.

ARTHUR J. DINES & CO.,
barristers & solicitors,
2A Highlands Road, Thomastown 3074.

Creditors, next-of-kin and others having claims against the estate of MURIEL HAMILTON KENNEDY, late of Unit 1, 6 Mountain Grove, Kew, Victoria, widow, deceased, who died on 1 February 2000 are requested to send particulars of their claims to the executors care of the undermentioned solicitors by 20 June 2000 after which date they will distribute the assets having regard only to the claims at which date they then had notice.

CHESSELL WILLIAMS, lawyers,
Level 13, 379 Collins Street, Melbourne 3000.

ARTHUR GRAEME MITCHELL, late of "Milands", RMB 221, Watchupga, Woomelang, Victoria, primary producer, deceased. Creditors, next-of-kin and others having claims in respect of the estate of the deceased, who died on 7 October 1999, are required by the trustees, Vivienne Grace Jean Mitchell and Alan Robert Mitchell, to send particulars to them care of the undermentioned solicitors by 7 June 2000 after which date the trustees may convey or distribute

the assets having regard only to the claims of which they then have notice.

GARDEN & GREEN, solicitors,
4 McCallum Street, Swan Hill.

ALICE GUILFORD, late of Brooklyn House, 132 Aphrasia Street, Newtown, deceased. Creditors, next-of-kin and others having claims in respect of the estate of the deceased, who died on 14 December 1999, are required by the trustee, Kevin Edward Roache of 235 Ryrie Street, Geelong, Victoria, solicitor, to send particulars to the trustee by 7 July 2000 after which date the trustee may convey or distribute the assets having regard only to the claims of which the trustee has notice.

GARGAN & ROACHE, solicitors,
235 Ryrie Street, Geelong.

LESLIE DOWTY BUSSEY, late of Apartment 11G, Edgewater Towers, 12 Marine Parade, St Kilda, in the State of Victoria. Creditors, next-of-kin and others having claims in respect of the estate of the deceased, who died on 16 November 1999, are required by the executor, Dorothy Clara Cash of Unit 1, 643 Hawthorn Road, East Brighton, in the said State, to send particulars to her care of the undermentioned solicitors by 15 June 2000 after which date the executor may convey or distribute the assets having regard only to the claims of which she then has notice.

GOLDSMITHS, barristers & solicitors,
13 Errol Street, North Melbourne 3051.

JEAN HILL, late of Vermont Private Nursing Home, 770 Canterbury Road, Vermont, Victoria, retired. Creditors, next-of-kin and others having claims in respect of the estate of the deceased, who died on 9 November 1998, are required by the administrator of her estate, Permanent Trustees Company Limited, A.C.N. 000 000 993, to send to it care of the undermentioned solicitors, particulars thereof by 20 June 2000 after which date it may convey or distribute the assets having regard only to the claims of which it then has notice.

HANLONS, solicitors,
Level 8, 454 Collins Street, Melbourne 3000.

Creditors, next-of-kin and others having claims in respect of the estate of CATHERINE DEMPSTER LONGSHAW, late of Unit 2, 15 Codrington Street, Sandringham, Victoria, widow, deceased, who died on 30 November 1999, are required by the executors namely, Neville Denis Kelly of 437 Centre Road, Bentleigh, Victoria, solicitor and Peter Thomas Longshaw of Unit 6, 69 Abbott Street, Sandringham, Victoria, retired manager, to send particulars of such claims to the solicitors acting for the said executors namely, Kelly & Chapman, 437 Centre Road, Bentleigh, Victoria, by 22 June 2000 after which date the said executors may convey or distribute the assets of the deceased having regard only to the claims of which they or their solicitors then have notice.

KELLY & CHAPMAN, solicitors,
437 Centre Road, Bentleigh.

NELLA GRZEGORCZUK, late of 29 Rosemary Drive, Lalor, Victoria, but formerly of 340 Edgars Road, Lalor, Victoria, widow, deceased. Creditors, next-of-kin and others having claims in respect of the estate of the deceased, who died on 13 March 2000, are required by the trustee, Grant Dinsmore of 48 Stanley Avenue, Eltham, Victoria, clerk, to send particulars to the trustee by 30 June 2000 after which date the trustee may convey or distribute the assets having regard only to the claims of which the trustee has notice.

LORRAINE JONES & ASSOCIATES,
solicitors,
900 Main Road, Eltham 3095.

PHETSOURINE VISISOMBAT of 26 Armstrong Way, North Dandenong, software consultant, deceased. Creditors, next-of-kin and others having claims in respect of the estate of the deceased, who died on 4 August 1999, are required by Colin Henry Madden of 40-42 Scott Street, Dandenong, solicitor, the executor of the will of the said deceased, to send particulars to him in the care of the undermentioned solicitors by 13 June 2000 after which date the said executor may convey or distribute the assets having regard only to the claims of which he then has notice.

MACPHERSON & KELLEY, solicitors,
40-42 Scott Street, Dandenong.

Creditors, next-of-kin and others having claims in respect of the estate of JOHN STEWART CAMERON, late of 18 Mansell Drive, Mildura, Victoria, accountant, deceased, who died on 26 November 1999, are required to send particulars of their claims to the executors care of the undermentioned solicitors by 13 June 2000 after which date the executors will distribute the assets having regard only to the claims of which they then have notice.

MASON SIER TURNBULL, solicitors,
5 Hamilton Place, Mount Waverley.

Creditors, next-of-kin and others having claims in respect of the estate of BETTY DENISE WILKS, late of 21 Rockingham Street, Kew, Victoria, but formerly of 2 Brook Street, Hawthorn, Victoria, married woman, deceased, who died on 25 August 1999, are required by the executor, ANZ Executors & Trustee Company Limited of 530 Collins Street, Melbourne, Victoria, to send particulars to it by 13 June 2000 after which date it may convey or distribute the estate having regard only to the claims of which it then has notice.

MILLS OAKLEY, lawyers,
131 Queen Street, Melbourne.

WIESLAWA HELENA SCHMIDT, late of 6 Frogmore Road, Murrumbeena, Victoria, retired doctor, deceased. Creditors, next-of-kin and others having claims in respect of the estate of the deceased, who died on 15 December 1998, are required by the trustee, Rozanna Zalewski of 45 Alfred Crescent, North Fitzroy, Victoria, barrister, to send particulars to the trustee by 25 June 2000 after which date the trustee may convey or distribute the assets having regard only to the claims of which the trustee then has notice.

OAKLEY THOMPSON & CO., solicitors,
Level 17, 500 Collins Street, Melbourne.

ASLE NOEL CHILTON, late of 302 Inkerman Street, East St Kilda. Creditors, next-of-kin and others having claims in respect of the estate of the deceased, who died on 22 November 1999, are required by Perpetual Trustees Victoria Limited, A.C.N. 004 027 258 of 50 Queen Street, Melbourne, to send particulars of their claims to the said company by 14 June 2000 after which date it will convey or distribute the assets having regard only to the claims of which the company then has notice.

Estate DOROTHY GERTRUDE O'LOUGHLIN deceased, late of Unit 5, 32 Harriette Street, Neutral Bay, New South Wales, home duties. Creditors, next-of-kin and others having claims in respect of the estate of the deceased, who died between 19 and 21 September 1999, are required by the personal representatives of the estate, Steven Morawsky of 1A Evelina Street, Mont Albert North, Victoria, accountant and Edward Alexander King Irving of Bourke Place, 600 Bourke Street, Melbourne, Victoria, solicitor, to send particulars to them care of 1A Evelina Street, Mont Albert North, Victoria, by 15 June 2000 after which date the personal representatives may convey or distribute the assets having regard only to the claims of which they then have notice.

PETER J. WALSH CARROLL KIERNAN & FORREST, solicitors,
83 William Street, Melbourne, Victoria 3000.

Creditors, next-of-kin and others having claims in respect of the estate of MARY ELIZABETH CAMPBELL, late of 2B Ferndale Road, Glen Iris, Victoria, home duties, deceased, who died on 2 January 2000, are to send particulars of their claims to Trust Company of Australia Limited, A.C.N. 004 027 749, the executor appointed by the will care of the undersigned by 13 June 2000 after which date they will commence to distribute the assets having regard only to the claims of which they then have notice.

RENNICK & GAYNOR, solicitors,
431 Riversdale Road, Hawthorn East.

Creditors, next-of-kin and others having claims in respect of the estate of EILEEN MARY SALVANA, late of "Gracedale", 205 Warrandyte Road, Ringwood North, Victoria, widow, deceased, who died on 2 September 1999, are to send particulars of their claims to Clare Marguerite Ringin and Elena Maria Salvana, the executrices appointed by the will, care of the undersigned by 13 June 2000 after which date they will commence to distribute the assets having regard only to the claims of which they then have notice.

RENNICK & GAYNOR, solicitors,
431 Riversdale Road, Hawthorn East.

ROMA MARGARET HALL, late of 62 Murray Street, Rye, Victoria, widow, deceased. Creditors, next-of-kin and others having claims in respect of the estate of the deceased, who died on 26 September 1999, are required to send particulars of their claims to the trustee, Shane Christopher McCarthy, care of the undermentioned solicitors by 19 June 2000 after which date the trustee will distribute the assets of the estate having regard only to the claims of which he then has notice.

S. C. McCARTHY & CO. PTY., solicitors,
2247 Point Nepean Road, Rye 3941.

HERBERT STANLEY STRINGER, late of "Sorrento Lodge, Ocean Beach Road, Sorrento, Victoria, retired, deceased. Creditors, next-of-kin and others having claims in respect of the estate of the deceased, who died on 2 October 1999, are required to send particulars of their claims to the trustees, Shane Christopher McCarthy and Gordon Walter Stringer, care of the undermentioned solicitors by 19 June 2000 after which date the trustees will distribute the assets of the estate having regard only to the claims of which they have notice.

S. C. McCARTHY & CO. PTY., solicitors,
2247 Point Nepean Road, Rye 3941.

FREDERICK CEASAR SULLIVAN, late of Flat 10, 20 Hawson Avenue, Glenhuntly, Victoria, retired, deceased. Creditors, next-of-kin and others having claims in respect of the estate of the abovenamed deceased, who died on 23 January 2000, are to send particulars of their claims to the executors, Richard John Booth and Timothy John Mulvany, care of the undermentioned solicitors by 15 June 2000 after which date the said executors will distribute the assets having regard only to the claims of which they then have notice.

T. J. MULVANY & CO., solicitors,
2nd Floor, 51 Queen Street, Melbourne 3000.

Creditors, next-of-kin and others having claims against the estate of LUISE VERONIKA DOH, late of 41 Elizabeth Street, Bayswater, Victoria, spinster, deceased, who died on 14 February 2000, are required to send particulars of their claims to Peter George Weller and John Patrick Toohey, both of 389 Lonsdale Street,

Melbourne, Victoria, legal practitioners, the executors of the will of the said deceased, on or before the 13 June 2000 after which date they will distribute the assets having regard only to the claims of which they then have notice.

TOLHURST DRUCE & EMMERSON,
solicitors,
389 Lonsdale Street, Melbourne.

LYLIA MARY HEINTZ, late of 41 Mitchell Parade, Pascoe Vale South, Victoria, widow, deceased. Creditors, next-of-kin and all other persons having claims against the estate of the said deceased, are required by Lynne Marie Anderson, executrix of the estate of the said deceased, to send particulars of such claims to her care of the undermentioned solicitors on or before 13 June 2000 after which date they will distribute the estate having regard only to the claims of which they then have notice.

WILLIAM MURRAY, solicitors,
411 Collins Street, Melbourne 3000.

Susan Bath of 1/1 Leane Drive, Eltham, joint proprietor with Anthony John Bath of an estate in fee simple in the land described on Certificate of Title Volume 10062, Folio 932 upon which is erected a dwelling known as 1/1 Leane Drive, Eltham.

Registered Mortgage No. T058703Q, Caveat No. W196077E, the covenant contained in Instrument K364135 and the Agreement No. R842407Q affect the said estate and interest.

Terms - Cash only.

SW-99-010585-7.

Dated 13 April 2000.

S. BLOXIDGE
Sheriff's Office

In the Supreme Court of the State of Victoria
SALE BY THE SHERIFF

On 18 May 2000 at 2.30 p.m. at the Sheriff's Office, 8-20 King Street, Oakleigh, (unless process be stayed or satisfied).

All the estate and interest (if any) of Emanuel Page of 74 Epsom Road, Laverton South, proprietor of an estate in fee simple in the land described on Certificate of Title Volume 9176, Folio 713 upon which is erected a residence known as 74 Epsom Road, Laverton South.

Registered Mortgage No. T144310S affects the said estate and interest.

Terms - Cash only.

SW-98-012305-1.

Dated 13 April 2000.

S. BLOXIDGE
Sheriff's Office

In the Supreme Court of the State of Victoria
SALE BY THE SHERIFF

On 18 May 2000 at 2.30 p.m. at the Sheriff's Office, 8-20 King Street, Oakleigh, (unless process be stayed or satisfied).

All the estate and interest (if any) of Gail

Unclaimed Moneys Act 1962

Register of Unclaimed Moneys held by the —

<i>Name of Owner on Books and Last Known Address</i>	<i>Total Amount Due to Owner</i>	<i>Description Of Unclaimed Money</i>	<i>Date when Amount first became Payable</i>
JUDY STEVENS & JAN GROSS			
	\$		
Y. & K. Beckers, 750 – 11th Street, South Naples, Florida, USA 99195 CONTACT: JAN GROSS, PHONE: (03) 9787 6171	220.96	Cheque	29/03/96

Unclaimed Moneys Act 1962

Register of Unclaimed Moneys held by the —

<i>Name of Owner on Books and Last Known Address</i>	<i>Total Amount Due to Owner</i>	<i>Description Of Unclaimed Money</i>	<i>Date when Amount first became Payable</i>
TESKACARSON			
	\$		
497 Burke Road, Camberwell 99200 CONTACT: JOHN A. CARSON, PHONE: (03) 9428 2600.	422.65	Cheque	01/07/96

Unclaimed Moneys Act 1962

Register of Unclaimed Moneys held by the —

<i>Name of Owner on Books and Last Known Address</i>	<i>Total Amount Due to Owner</i>	<i>Description Of Unclaimed Money</i>	<i>Date when Amount first became Payable</i>
CITY OF BOROONDARA			
	\$		
H. M. Cleaners, 12 Glenora Court, Frankston	160.00	Cheque	26/03/98
Raeco, Locked Bag 243 MDA, Knoxfield	627.80	"	08/05/98
Ultra Safe Security, 33/170 Forster Road, Mount Waverley	636.00	"	09/12/98
Ms R. Bickley, 15A Fordham Avenue, Camberwell	165.80	"	10/02/99
V. G. & J. W. Maslen, 2/23 Ashburn Grove, Ashburton	135.00	"	03/03/99
00020 CONTACT: EMMA MANYATIS, PHONE: (03) 9278 4306.			

Unclaimed Moneys Act 1962

Register of Unclaimed Moneys held by the —

<i>Name of Owner on Books and Last Known Address</i>	<i>Total Amount Due to Owner</i>	<i>Description Of Unclaimed Money</i>	<i>Date when Amount first became Payable</i>
REPCO			
	\$		
Fessel Pty Ltd	1,128.41	Cheque	23/04/93
00015 CONTACT: MAUREEN PIRIE, PHONE: (03) 9566 5444.			

Unclaimed Moneys Act 1962

Register of Unclaimed Moneys held by the —

<i>Name of Owner on Books and Last Known Address</i>	<i>Total Amount Due to Owner</i>	<i>Description Of Unclaimed Money</i>	<i>Date when Amount first became Payable</i>
NEW LIFESTYLE LIGHTING PTY LTD			
	\$		
Essmat, P.O. Box 222, Somerton	1,599.03	Cheque	29/01/99
Eunice Taylor Ltd, 303 Auburn Road, Hawthorn East	109.63	"	"
00004 CONTACT: NICOLE KELLY, PHONE: (03) 9611 6611.			

Unclaimed Moneys Act 1962

Register of Unclaimed Moneys held by the —

<i>Name of Owner on Books and Last Known Address</i>	<i>Total Amount Due to Owner</i>	<i>Description Of Unclaimed Money</i>	<i>Date when Amount first became Payable</i>
COLONIAL LANTERN PTY LTD			
	\$		
Essmat, P.O. Box 222, Somerton	2,933.62	Cheque	29/01/99
Eunice Taylor Ltd, 303 Auburn Road, Hawthorn East	240.06	"	"
00005 CONTACT: NICOLE KELLY, PHONE: (03) 9611 6611.			

Unclaimed Moneys Act 1962

Register of Unclaimed Moneys held by the —

<i>Name of Owner on Books and Last Known Address</i>	<i>Total Amount Due to Owner</i>	<i>Description Of Unclaimed Money</i>	<i>Date when Amount first became Payable</i>
MULLER INDUSTRIES AUSTRALIA PTY LTD			
\$			
Webforge (Vic) Pty Ltd, Private Bag 155, Clayton South 00006 CONTACT: NICOLE KELLY, PHONE: (03) 9611 6611.	191.81	Cheque	08/03/99

Unclaimed Moneys Act 1962

Register of Unclaimed Moneys held by the —

<i>Name of Owner on Books and Last Known Address</i>	<i>Total Amount Due to Owner</i>	<i>Description Of Unclaimed Money</i>	<i>Date when Amount first became Payable</i>
AUSTRALIAN MARKETING INSTITUTE			
\$			
Monash Info Service, Cashiers Office, Monash Uni., Clayton Reed Business Publishing, P.O. Box 5487, West Chatswood, NSW	139.35	Cheque	02/06/98
Monash Info Service, Cashiers Office, Monash Uni., Clayton	9,584.22	"	"
	185.80	"	11/03/99
00007 CONTACT: NICOLE KELLY, PHONE: (03) 9611 6611.			

Unclaimed Moneys Act 1962

Register of Unclaimed Moneys held by the —

<i>Name of Owner on Books and Last Known Address</i>	<i>Total Amount Due to Owner</i>	<i>Description Of Unclaimed Money</i>	<i>Date when Amount first became Payable</i>
SHELL SERVICES INTERNATIONAL			
\$			
Smorgon Fencing, P.O. Box 11, Bentley, WA	100.00	Cheque	21/01/97
Universal Stud Bolts, P.O. Box 1554, Canning Vale, WA	135.60	"	24/02/97
Pivot Limited, P.O. Box 14826, Melbourne Mail Centre	1,371.87	"	01/05/97
Jetsroad, Locked Bag 18, Tullamarine University of New South Wales,	192.58	"	02/06/97

University of NSW Careers Service, Sydney, NSW	180.00	”	23/06/97
Brisbane City Council, P.O. Box 1090 Brisbane, Qld	2,868.20	”	26/06/97
Spectrum Distributors, P.O. Box 2762 Sydney, NSW	2,340.00	”	06/10/97
NYAC 1997, P.O. Box 380, Sydney, NSW	140.00	”	06/11/97
Goulburn Base Hospital, Graham Street, Shepparton	127.37	”	20/11/97

99194

CONTACT: PAUL HITCHENS, PHONE: (03) 9666 5444.

Unclaimed Moneys Act 1962

Register of Unclaimed Moneys held by the —

<i>Name of Owner on Books and Last Known Address</i>	<i>Total Amount Due to Owner</i>	<i>Description Of Unclaimed Money</i>	<i>Date when Amount first became Payable</i>
--	--	---	--

AUSTRALIAN UNITED INVESTMENT COMPANY LIMITED

\$

Federal Securities Pty Ltd, G.P.O. Box 97, Hobart, Tas.	4,256.62	Cheque	19/05/97
Mr Clement Thomas Michael Jensen, 181 Ritchie Road, Pallara, Qld	675.26	”	07/10/97

98115

CONTACT: TERRY McGRATH, PHONE: (03) 9611 5711.

Unclaimed Moneys Act 1962

Register of Unclaimed Moneys held by the —

<i>Name of Owner on Books and Last Known Address</i>	<i>Total Amount Due to Owner</i>	<i>Description Of Unclaimed Money</i>	<i>Date when Amount first became Payable</i>
--	--	---	--

AUSTIN GROUP LIMITED

\$

Verand Investments Pty Ltd, “Verand Unit A/C”, C/- Robert Vernali & Co, P.O. Box 506, Carlton	240.00	Cheque	16/12/97
--	--------	--------	----------

99020

CONTACT: TERRY McGRATH, PHONE: (03) 9611 5711.

Unclaimed Moneys Act 1962

Register of Unclaimed Moneys held by the —

<i>Name of Owner on Books and Last Known Address</i>	<i>Total Amount Due to Owner</i>	<i>Description Of Unclaimed Money</i>	<i>Date when Amount first became Payable</i>
AUSTIN GROUP LIMITED			
	\$		
Verand Investments Pty Ltd, "Verand Unit A/C", C/- Robert Vernali & Co, P.O. Box 506, Carlton 99020 CONTACT: TERRY McGRATH, PHONE: (03) 9611 5711.	240.00	Cheque	16/12/97

Unclaimed Moneys Act 1962

Register of Unclaimed Moneys held by the —

<i>Name of Owner on Books and Last Known Address</i>	<i>Total Amount Due to Owner</i>	<i>Description Of Unclaimed Money</i>	<i>Date when Amount first became Payable</i>
EAST AFRICAN COFFEE PLANTATIONS LIMITED			
	\$		
M/s Hilda M. Hall, Decd, C/- Mr W. J. Hall, 6 Electra Street, Williamstown 99023 CONTACT: TERRY McGRATH, PHONE: (03) 9611 5711.	111.84	Cheque	30/05/97

Unclaimed Moneys Act 1962

Register of Unclaimed Moneys held by the —

<i>Name of Owner on Books and Last Known Address</i>	<i>Total Amount Due to Owner</i>	<i>Description Of Unclaimed Money</i>	<i>Date when Amount first became Payable</i>
DIVERSIFIED UNITED INVESTMENT LIMITED			
	\$		
Mrs Katherine Mary Pratt, U P Farm, Wickhams Hill Road, Meadows, SA 99024 CONTACT: TERRY McGRATH, PHONE: (03) 9611 5711.	140.00	Cheque	15/09/97

Unclaimed Moneys Act 1962

Register of Unclaimed Moneys held by the —

<i>Name of Owner on Books and Last Known Address</i>	<i>Total Amount Due to Owner</i>	<i>Description Of Unclaimed Money</i>	<i>Date when Amount first became Payable</i>
EQUITY TRUSTEES LIMITED			
	\$		
Mr Christopher Matthew Lines, 20 Renown Avenue, Tranmere, SA 99025 CONTACT: TERRY McGRATH, PHONE: (03) 9611 5711.	150.36	Cheque	11/09/97

Unclaimed Moneys Act 1962

Register of Unclaimed Moneys held by the —

<i>Name of Owner on Books and Last Known Address</i>	<i>Total Amount Due to Owner</i>	<i>Description Of Unclaimed Money</i>	<i>Date when Amount first became Payable</i>
COUNTRY ROAD LIMITED			
	\$		
B K Wilson Pty Limited, Unit 8, 18 Small Street, Woollahra, NSW Veysonnaz Investments Pty Ltd, 11/43 Murray Street, Bronte, NSW	100.00	Cheque	23/05/97
	181.80	”	30/06/97
99026 CONTACT: TERRY McGRATH, PHONE: (03) 9611 5711.			

Unclaimed Moneys Act 1962

Register of Unclaimed Moneys held by the —

<i>Name of Owner on Books and Last Known Address</i>	<i>Total Amount Due to Owner</i>	<i>Description Of Unclaimed Money</i>	<i>Date when Amount first became Payable</i>
GREENCHIP INVESTMENTS LIMITED			
	\$		
Mr John Harold Dracott & Mrs Joan Gladwys Dracott, 84 Allpass Parade, Shornecliffe, Qld Mr Mark Houston, “Vizomont P/L Super Fund A/C”,	106.25	Cheque	23/05/97

Victoria Government Gazette *G 15 13 April 2000 691*

46 Hilton Road, Ferny Creek	126.25	"	"
Mrs Patricia Houston "Vizomont P/L Super Fund A/C", 46 Hilton Road, Ferny Creek	126.25	"	"
Mr Anthony James Johnson, "Vizomont P/L Super Fund A/C", 46 Hilton Road, Ferny Creek	126.25	"	"
Towermont Investments Pty Ltd, P.O. Box 686 Sandy Bay, Tas.	100.00	"	"

99027

CONTACT: TERRY McGRATH, PHONE: (03) 9611 5711.

Unclaimed Moneys Act 1962

Register of Unclaimed Moneys held by the —

<i>Name of Owner on Books and Last Known Address</i>	<i>Total Amount Due to Owner</i>	<i>Description Of Unclaimed Money</i>	<i>Date when Amount first became Payable</i>
PALMER CORPORATION LIMITED			
	\$		
Arcaro Holdings Pty Ltd, 1/17 Southport St, Leederville, WA	120.00	Cheque	01/12/97
Robert Barth, 21 East 10th Street, New York 10003 USA	120.00	"	"
Geoffrey William Boyd-Boland, 1/4A Mosman Street, Mosman NSW	150.00	"	"
Kevin Crehan, C/-Corporate Registry Services Pty Ltd, G.P.O. Box 2975EE, Melbourne	750.00	"	"
Jonathan Charles Gray, 368 Rokeby Road, Subiaco, WA	150.00	"	"
Sarah Virginia Harden, 55 Haldon Road, London SW181 QF UK	120.00	"	"
Mr Mark Logan Hodge, 171 Stamford Avenue, Stamford Ct 06902 USA	300.00	"	"
Mary Carole Elizabeth Roache & Stuart Paul Roache, P.O. Box 7177 Lpo, Gardenvale	150.00	"	"
Sunpand Pty Ltd, 25 Barnon Avenue, Keilor	150.00	"	"
Margaret May Tabberer, 11 Hampden Ave, Darling Point, NSW	300.00	"	"

99029

CONTACT: TERRY McGRATH, PHONE: (03) 9611 5711.

Unclaimed Moneys Act 1962

Register of Unclaimed Moneys held by the —

<i>Name of Owner on Books and Last Known Address</i>	<i>Total Amount Due to Owner</i>	<i>Description Of Unclaimed Money</i>	<i>Date when Amount first became Payable</i>
MCPHERSONS LIMITED			
	\$		
D R A Holdings Pty Ltd "Bayunga", Box 36, Nagambie	115.40	Cheque	31/10/97
D R A Holdings Pty Ltd "Bayunga", Box 36, Nagambie	158.68	"	30/04/97

Est Wilma Marie Ferrari, C/- P W Ferrari 42 Rose Street, McKinnon	168.36	”	”
Lilian Edwards Holdings Pty Ltd, C/- Computershare Registry Services Pty Ltd, G.P.O. Box 2848EE, Melbourne	145.80	”	31/10/97
Lilian Edwards Holdings Pty Ltd, C/- Computershare Registry Services Pty Ltd, G.P.O. Box 2848EE, Melbourne	200.48	”	30/04/97
Mr Charles William Rudd, 5 Beddows St, Burwood	139.81	”	30/04/97
Mr Charles William Rudd, 5 Beddows St, Burwood	101.68	”	31/10/97
Mrs Jessie M. Taylor, 12 Nagle Place, North Turrumurra, NSW	122.00	”	”

99030

CONTACT: TERRY McGRATH, PHONE: (03) 9611 5711.

Unclaimed Moneys Act 1962

Register of Unclaimed Moneys held by the —

<i>Name of Owner on Books and Last Known Address</i>	<i>Total Amount Due to Owner</i>	<i>Description Of Unclaimed Money</i>	<i>Date when Amount first became Payable</i>
STRUCTURAL SYSTEMS LIMITED			
	\$		
Miss Stephanie Bem, 89 Cole Street, Gardenvale	133.10	Cheque	02/04/97
Miss Stephanie Bem, 89 Cole Street, Gardenvale	186.34	”	10/10/97

99031

CONTACT: TERRY McGRATH, PHONE: (03) 9611 5711.

Unclaimed Moneys Act 1962

Register of Unclaimed Moneys held by the —

<i>Name of Owner on Books and Last Known Address</i>	<i>Total Amount Due to Owner</i>	<i>Description Of Unclaimed Money</i>	<i>Date when Amount first became Payable</i>
TEMPLETON GLOBAL GROWTH FUND LIMITED			
	\$		
Sonya Lulic, P.O. Box H177 Harris Park, NSW	200.00	Cheque	26/03/97
Mr Wu Ng, C/- Changi Airport, P.O. Box 0322 Singapore 9181	120.00	”	”

99032

CONTACT: TERRY McGRATH, PHONE: (03) 9611 5711.

Unclaimed Moneys Act 1962

Register of Unclaimed Moneys held by the —

<i>Name of Owner on Books and Last Known Address</i>	<i>Total Amount Due to Owner</i>	<i>Description Of Unclaimed Money</i>	<i>Date when Amount first became Payable</i>
CANADA LAND LIMITED			
	\$		
Malcolm Payne & Associates Pty Ltd, "Malcolm Payne 1992 S/F A/C", C/- Ellis Cherry, Ground Floor, 22 William Street, Melbourne	360.00	Cheque	19/12/97
Malcolm Payne & Associates Pty Ltd, "Malcolm Payne 1992 S/F A/C", C/- Ellis Cherry, Ground Floor, 22 William Street, Melbourne	230.00	"	15/08/97
Rivage Holdings Limited, The Lake Building, 1st Floor, Wickhams Lay, P.O. Box 3175, Road Town, Tortola, British Virgin Islands	288.00	"	19/12/97
Rivage Holdings Limited, The Lake Building, 1st Floor, Wickhams Lay, P.O. Box 3175, Road Town, Tortola, British Virgin Islands	184.00	"	15/08/97

99090

CONTACT: TERRY McGRATH, PHONE: (03) 9611 5711.

Unclaimed Moneys Act 1962

Register of Unclaimed Moneys held by the —

<i>Name of Owner on Books and Last Known Address</i>	<i>Total Amount Due to Owner</i>	<i>Description Of Unclaimed Money</i>	<i>Date when Amount first became Payable</i>
COLONIAL FIRST STATE INDUSTRIAL PROPERTY TRUST			
	\$		
Est Shiu-Chung Lee, C/- Henry Davis York, Level 25, 135 King Street, Sydney, NSW	518.30	Cheque	21/11/97
Est Shiu-Chung Lee, C/- Henry Davis York, Level 25, 135 King Street, Sydney, NSW	508.17	"	22/08/97

99092

CONTACT: TERRY McGRATH, PHONE: (03) 9611 5711.

Unclaimed Moneys Act 1962

Register of Unclaimed Moneys held by the —

<i>Name of Owner on Books and Last Known Address</i>	<i>Total Amount Due to Owner</i>	<i>Description Of Unclaimed Money</i>	<i>Date when Amount first became Payable</i>
CROWN LIMITED			
	\$		
Mr Colin Barrie & Mrs Lynette Barrie, 218 Village Baxter, 8 Robinsons Road, Baxter	567.41	Cheque	17/02/97
Mr Colin Barrie & Mrs Lynette Barrie, 218 Village Baxter, 8 Robinsons Road, Baxter	562.31	"	15/08/97
Mrs Christine Elizabeth Bennett & Mr Robert McKay 24 Cuba Street, Petone, Wellington 6008, New Zealand	446.30	"	"
Cigar Nominee Pty Limited, P.O. Box N132, Grosvenor Place, Sydney, NSW	204.81	"	01/12/97
Eskimo Downs Pty Limited, "Eskimo Downs P/L Super A/C", 229 Glenhuntly Road, Elsternwick	471.10	"	15/08/97
Eskimo Downs Pty Limited, "F H Jacobs Alocted Pens A/C", 229 Glenhuntly Road, Elsternwick	471.10	"	"
Ms Dau Caliu Gruia, 36 Douglas Street, St. Ives, NSW	495.89	"	"
Mr David Ashley Rains & Mrs Mara Anne Rains, "Rains Superfund A/C", P.O. Box 6123, Halifax Street, Adelaide, SA	355.27	"	02/06/97
Rapniw Pty Limited, 11/219 Kissing Point Road, Turrumurra, NSW	502.73	"	17/02/97
Sarai Pty Limited, "Mc Ritchie Family S/F A/C", P.O. Box 328, Erindale, ACT	495.89	"	15/08/97
Mr David William Smith & Mr Michael James Weston Smith, 39 Cook Road, Killara, NSW	103.19	"	17/02/97
Mr David William Smith & Mr Michael James Weston Smith, 39 Cook Road, Killara, NSW	198.36	"	15/08/97
Teamco Nominees Pty Ltd, "Rbs Superannuation" 79 Arterial Road, St. Ives, NSW	402.19	"	17/02/97
	396.71	"	15/08/97

99093

CONTACT: TERRY McGRATH, PHONE: (03) 9611 5711.

Unclaimed Moneys Act 1962

Register of Unclaimed Moneys held by the —

<i>Name of Owner on Books and Last Known Address</i>	<i>Total Amount Due to Owner</i>	<i>Description Of Unclaimed Money</i>	<i>Date when Amount first became Payable</i>
GANDEL RETAIL TRUST			
	\$		
Mr Glenn Bermingham, 6 Rowland Street, Mont Albert	402.00	Cheque	25/08/97
Mr Glenn Bermingham, 6 Rowland Street, Mont Albert	388.00	"	27/02/97
Ms Kerry Margaret Crowley, 29 Washington Street, Upfield	202.60	"	25/08/97
Ms Kerry Margaret Crowley, 29 Washington Street, Upfield	195.55	"	27/02/97
Mrs Jacqueline S. Czislowksi, 1/6 Grange Road, Toorak	482.40	"	25/08/97
Mrs Jacqueline S. Czislowksi, 1/6 Grange Road, Toorak	465.60	"	27/02/97
Ormsec Management Services Pty Ltd, "Superannuation Fund A/C", 11 Margaret Court, Warrandyte	126.30	"	25/08/97
Mr Tim Weng, Unit 4, 60-66 Clarendon St, East Melbourne	232.80	"	27/02/97

99095

CONTACT: TERRY McGRATH, PHONE: (03) 9611 5711.

Unclaimed Moneys Act 1962

Register of Unclaimed Moneys held by the —

<i>Name of Owner on Books and Last Known Address</i>	<i>Total Amount Due to Owner</i>	<i>Description Of Unclaimed Money</i>	<i>Date when Amount first became Payable</i>
EASTERN ALUMINIUM LIMITED			
	\$		
Mr Robert Campbell Burns, 21 Justin St, Holland Park, Qld	200.00	Cheque	19/09/97
Ms Judy Ee Apt, 303 89 Beach Street, Port Melbourne	200.00	"	19/03/97
Ms Judy Ee Apt, 303 89 Beach Street, Port Melbourne	400.00	"	19/09/97
Gap Consultancts Pty Ltd, 29/31 White St, Tamworth, NSW	160.00	"	"
Nyco Pty Limited, "N A Curtis Super Fund A/C", C/- Nicholas Curtis, Level 27, 20 Bond Street, Sydney, NSW	100.00	"	"
Mr William Arthur Thompson, Tebbutt Lodge, 40a Stewart Street, Dundas, NSW	400.00	"	"

99094

CONTACT: TERRY McGRATH, PHONE: (03) 9611 5711.

Unclaimed Moneys Act 1962

Register of Unclaimed Moneys held by the —

<i>Name of Owner on Books and Last Known Address</i>	<i>Total Amount Due to Owner</i>	<i>Description Of Unclaimed Money</i>	<i>Date when Amount first became Payable</i>
GES INTERNATIONAL LIMITED			
\$			
BBDS Holdings Limited, C/- Chilar Investments Ltd Prince's Building, Suite 1408, 10 Chater Road, Hong Kong	613.20	Cheque	28/11/97
M/s Elaine Man Chow, 157 Deepwater Rd, Castle Cove, Chou Chen Pi Chu, 2/F No 8 Lane 235, Bao Chiao Road Globald Ind Center Hsin Tien, Taiwan	420.00	"	"
Hui Hsien Ho, 41 Jalan Baiduri, Singapore 428412	560.00	"	"
Geok Choo Lim, 49 Meragi Road, Singapore 487926	145.60	"	"
Chou Chih Lung, 2/F No 8 Lane 235, Bao Chiao Road, Globald Ind Center Hsin Tien, Taiwan	112.00	"	"
Macwil Nominees Pty Ltd, C/- Mckinley Wilson & Co, 459 Collins Street, Melbourne	560.00	"	"
Towerview Restaurant Pty Ltd, P.O. Box 86, New Gisborne	140.00	"	"
	112.00	"	"

99096

CONTACT: TERRY McGRATH, PHONE: (03) 9611 5711.

Unclaimed Moneys Act 1962

Register of Unclaimed Moneys held by the —

<i>Name of Owner on Books and Last Known Address</i>	<i>Total Amount Due to Owner</i>	<i>Description Of Unclaimed Money</i>	<i>Date when Amount first became Payable</i>
GRAND HOTEL GROUP			
\$			
Chun-Hung Chen, 3 Dungarvan Court, Waterford, WA	178.00	Cheque	29/08/97

99098

CONTACT: TERRY McGRATH, PHONE: (03) 9611 5711.

Unclaimed Moneys Act 1962

Register of Unclaimed Moneys held by the —

<i>Name of Owner on Books and Last Known Address</i>	<i>Total Amount Due to Owner</i>	<i>Description Of Unclaimed Money</i>	<i>Date when Amount first became Payable</i>
GREAT CENTRAL MINES LIMITED			
\$			
Appraisult Consultants Limited, 32 Ara Street, Remuera, Auckland 1105, New Zealand	612.00	Cheque	11/04/97
Appraisult Consultants Limited, 32 Ara Street, Remuera, Auckland 1105, New Zealand	612.00	"	10/10/97
Mr Warren James Burns, 173-175 Heatherdale Road, Vermont	351.00	"	11/04/97
Burvon Nominees Pty Ltd, C/- Bird Cameron, P.O. Box 685, Ballarat	772.50	"	10/10/97
Mr Ian James Cameron, 23 Victoria Street, Cairns, Qld	150.00	"	11/04/97
Coronet Resources Limited, Attn: Mr Gabriel Sadte, 301 Park Avenue, New York, New York 10022 U S A	16,158.84	"	"
Coronet Resources Limited, Attn: Mr Gabriel Sadte, 301 Park Avenue, New York, New York 10022 U S A	16,158.84	"	10/10/97
Mr Mendey Groner, 1649 President Street, Brooklyn New York, 1123 U S A	191.25	"	"
Hanijam Pty Limited, "Hanijam Super Fund A/C", 21/27 Rickard Road, Bankstown, NSW	120.00	"	"
Rabbi Tzeire Agudath Jabad Association Israelita Argentina Aguers 1164, 1425 Buenos Aires, Argentine	957.60	"	11/04/97
Rabbi Tzeire Agudath Jabad Association Israelita Argentina Aguers 1164, 1425 Buenos Aires, Argentine	957.60	"	10/10/97
Jentren Pty Limited, "Supernational Unit A/C", 358 Darling Street, Balmain, NSW	741.60	"	"
Jentren Pty Limited, "Supernational Unit A/C", 358 Darling Street, Balmain, NSW	738.70	"	11/04/97
Wexler Securities Pty Ltd, 616 Warrigal Road, Malvern 99099	260.79	"	10/10/97
CONTACT: TERRY McGRATH, PHONE: (03) 9611 5711.			

Unclaimed Moneys Act 1962

Register of Unclaimed Moneys held by the —

<i>Name of Owner on Books and Last Known Address</i>	<i>Total Amount Due to Owner</i>	<i>Description Of Unclaimed Money</i>	<i>Date when Amount first became Payable</i>
GREENCHIP EMERGING GROWTH LIMITED			
\$			
Mrs Thelma Elliott, Box 790, Geraldton, WA	6,200.00	Cheque	30/05/97
Michael Scott, P.O. Box 686. Sandy Bay, Tas. 99101	1,550.00	"	"
CONTACT: TERRY McGRATH, PHONE: (03) 9611 5711.			

Unclaimed Moneys Act 1962

Register of Unclaimed Moneys held by the —

<i>Name of Owner on Books and Last Known Address</i>	<i>Total Amount Due to Owner</i>	<i>Description Of Unclaimed Money</i>	<i>Date when Amount first became Payable</i>
HUDSON CONWAY LIMITED			
	\$		
Miss Alison Maree Butler, 44 Mary Dreaver Street, Blockhouse Bay, Auckland 7, New Zealand	100.00	Cheque	28/11/97
Ms Lynda Jean Dacey, P.O. Box 25500, St Heliers, Auckland 5, New Zealand	300.00	"	"
Donard Services Pty Ltd, 1 Latrobe Street, Mentone	500.00	"	"
Fibuzi Pty Limited 22 Neridah Street Chatswood, NSW 2067	500.00	"	"
Mr Raymond Franklin Soames Job & Mrs Nancy Coleen Job, 8 Second Avenue, Jannali, NSW	102.25	"	"
Mr Charles Steven Kaplan, C/- Australian Gilt, Level 5, 37-49 Pitt Street, Sydney, NSW	1,100.00	"	"
Joachim G R Kouwenhoven & Aleida Joanna M Kouwenhoven, 164 Glamorgan Dve, Torbay, Auckland 1310, NZ	250.00	"	"
L. J. Bradley Enterprises Pty Ltd. "Superannuation A/C", 94 Nelson Street, Wallsend, NSW	100.00	"	"
Miss Angela Maree Marasco, C/- McCaughan Dyson & Co Ltd, 360 Collins St, Melbourne	250.00	"	"
Mr John Marjoribanks & Mrs Mary Barrie Marjoribanks, 1/41 Calliope Road, Devonport, New Zealand	100.00	"	"
Mr Richard Robert Revill, 8 Wood Street, North Melbourne	140.00	"	"
Mr Dean Alexander Somerville, 4 Pitlochry Pl Howick, Auckland, New Zealand	100.00	"	"
Mr Herbert Zelcer, 2/5 Pukerangi Cres, Ellerslie, Auckland, New Zealand 99102	100.00	"	"
CONTACT: TERRY McGRATH, PHONE: (03) 9611 5711.			

Unclaimed Moneys Act 1962

Register of Unclaimed Moneys held by the —

<i>Name of Owner on Books and Last Known Address</i>	<i>Total Amount Due to Owner</i>	<i>Description Of Unclaimed Money</i>	<i>Date when Amount first became Payable</i>
PACIFICA GROUP LIMITED			
	\$		
Mr Paul Davis, 35 Shepparson Avenue, Carnegie	348.00	Cheque	09/05/97
Wygoss Pty Ltd, "P B Kelly Super Fund A/C", P.O. Box 182, Hornsby, NSW	176.00	"	"
Wygoss Pty Ltd, "P B Kelly Super Fund A/C", P.O. Box 182, Hornsby, NSW 99105	132.00	"	03/10/97
CONTACT: TERRY McGRATH, PHONE: (03) 9611 5711.			

Unclaimed Moneys Act 1962

Register of Unclaimed Moneys held by the —

<i>Name of Owner on Books and Last Known Address</i>	<i>Total Amount Due to Owner</i>	<i>Description Of Unclaimed Money</i>	<i>Date when Amount first became Payable</i>
PASMINGO LIMITED			
	\$		
Mr Paul Desmond Cohen, 53 Lambeth Street, Panania, NSW	320.00	Cheque	03/11/97
Conroys Pineapple Crunch, (George St) Pty Ltd, Unit 54, 6-12 Prospect Avenue, Cremorne, NSW	118.05	"	"
Mrs Marion Ferguson MacSwiney, 12 Onslow Gardens London N103ju United Kingdom	136.00	"	"
Mr Gillon Angus McLachlan & Mr Samuel Baillieu "Mercan Investment Account"			
C/- G. A. McLachlan, 91 Park Drive, Parkville Arthur Tony Muston, Dec'd & Mr Anthony John Muston, C/- Garland Seaborn, Barclays House, 25 Bligh Street, Sydney, NSW	235.65	"	"
Pikasu Pty Limited, "Superannuation Fund A/C", 14 Milner Avenue, Hornsby, NSW	165.10	"	"
Mr Denise Tozer, 3 Cooma Avenue, Goulburn, NSW	138.79	"	"
Ms Chu-Lan Tseng, 5f-1 No 1, Lane 102, Chi-Hsing Road, Chiao-Chou Ping-Tong, Taiwan	100.00	"	"
Voyager Holdings Pty Ltd, P.O. Box 971, Nedlands, WA	198.80	"	"
	216.10	"	"

99106

CONTACT: TERRY McGRATH, PHONE: (03) 9611 5711.

Unclaimed Moneys Act 1962

Register of Unclaimed Moneys held by the —

<i>Name of Owner on Books and Last Known Address</i>	<i>Total Amount Due to Owner</i>	<i>Description Of Unclaimed Money</i>	<i>Date when Amount first became Payable</i>
SKILLED ENGINEERING LTD			
	\$		
Mr Richard Ellis Benson, 99 Adelaide Parade, Woollahra, NSW	125.00	Cheque	17/10/97
Mr Yam Wan Wong & Mrs Li Ying Kiu Wong, P.O. Box 255, Box Hill	400.00	"	"

99107

CONTACT: TERRY McGRATH, PHONE: (03) 9611 5711.

Unclaimed Moneys Act 1962

Register of Unclaimed Moneys held by the —

<i>Name of Owner on Books and Last Known Address</i>	<i>Total Amount Due to Owner</i>	<i>Description Of Unclaimed Money</i>	<i>Date when Amount first became Payable</i>
S.P.C. LIMITED			
	\$		
McPherson Newspapers Pty Limited, P.O Box 204, Shepparton	865.26	Cheque	31/07/97
Yerba Pty Limited, "A/C Rbs Superannuation Fund" 79 Arterial Road, St Ives, NSW	188.10	"	"

99109

CONTACT: TERRY McGRATH, PHONE: (03) 9611 5711.

Unclaimed Moneys Act 1962

Register of Unclaimed Moneys held by the —

<i>Name of Owner on Books and Last Known Address</i>	<i>Total Amount Due to Owner</i>	<i>Description Of Unclaimed Money</i>	<i>Date when Amount first became Payable</i>
S.P.C. HOLDINGS LIMITED			
	\$		
Amaril Pty Ltd, 6/4 Churchill Avenue, Clarence Park, SA	145.02	Cheque	31/10/97
Axund Pty Ltd, 1202 Pacific Highway, Pymble, NSW	240.00	"	30/05/97
Axund Pty Ltd, 1202 Pacific Highway, Pymble, NSW	160.00	"	31/10/97
Dargenio David Boschetti, Decd, C/- KPMG Peat Marwick, G.P.O. Box 2975EE, Melbourne	105.60	"	30/05/97
William Morris Coldwell, Box 827, Shepparton	109.86	"	31/10/97
Robert Ian Sinclair, 87 Batman Avenue, Shepparton G.P.O. Box 2975EE, Melbourne	115.20	"	30/05/97

99110

CONTACT: TERRY McGRATH, PHONE: (03) 9611 5711.

Unclaimed Moneys Act 1962

Register of Unclaimed Moneys held by the —

<i>Name of Owner on Books and Last Known Address</i>	<i>Total Amount Due to Owner</i>	<i>Description Of Unclaimed Money</i>	<i>Date when Amount first became Payable</i>
SPOTLESS SERVICES LIMITED			
	\$		
M/s Annette Fortescue, C/-Corporate Registry Services Pty Ltd, G.P.O. Box 505H, Melbourne	235.98	Cheque	03/10/97
M/s Annette Fortescue, C/-Corporate Registry Services Pty Ltd, G.P.O. Box 505H, Melbourne	235.98	"	18/04/97
Goodwin Enterprises Pty Limited, P.O. Box 86, Caringbah, NSW	117.99	"	03/10/97
Goodwin Enterprises Pty Limited, P.O. Box 86, Caringbah, NSW	117.99	"	18/04/97
M/s Alison Caroline Williams Broome Hill, 375 Flaxbournes Road, Moriac	235.98	"	"

99113

CONTACT: TERRY McGRATH, PHONE: (03) 9611 5711.

Unclaimed Moneys Act 1962

Register of Unclaimed Moneys held by the —

<i>Name of Owner on Books and Last Known Address</i>	<i>Total Amount Due to Owner</i>	<i>Description Of Unclaimed Money</i>	<i>Date when Amount first became Payable</i>
VILLAGE ROADSHOW LIMITED			
	\$		
Bear Tooth International Inc., C/- G. L. Simpson, Lot 69, Millendon, WA	570.00	Cheque	26/11/97
Ms Elaine Diamond, 1 Oyster Landing, Milford Ct 06460 USA	212.50	"	"
Mr Wayne Doran, 41 Kalang Avenue, Lenah Valley, Tas.	114.00	"	"
Mr Daniel Fellman, 4 Lighthouse Street, Unit 8, Marina Del Ray California 90292, United States	186.15	"	"
Gatalea Pty Limited, C/- Ernst & Young Registry Services Pty Ltd, G.P.O. Box 505H, Melbourne	195.70	"	"
Miss Ying Ying Hui, 18f Royal Court,			

9m Kennedy Road, Wanchai, Hong Kong	227.50	”	”
Miss Natasha Alexandra Kassar, C/- Carolco Services, 8800 Sunset Boulevard Los Angeles, California 90069, United States	807.50	”	”
Mrs Julie Alice Kirby, C/-Corporate Registry Services, G.P.O. Box 505H, Melbourne	323.18	”	”
Ms Adrienne Dawn Martin, C/- Ernst & Young Registry Services Pty Ltd P.O. Box 505H, Melbourne	228.00	”	”
M/s Anna O'Connor, 8/136 Cross Road, Highgate, SA	2,361.50	”	”
Dr A. Holyweek Sarei & M/s Claire Sarei, C/- Mr Francis Seeto, 108 Flockton Street, Everton Park, Qld	244.60	”	”
Ms Jane Elizabeth Sherning, C/-Corporate Registry Services Pty Ltd, G.P.O. Box 505H, Melbourne	244.60	”	”
Dr Ravi Sidhu, 25 Clay Street New Farm, Brisbane, Qld	107.65	”	”
Mr John Walsh, C/- Walsh James, 5/17 Castlereagh Street, Sydney, NSW SYDNEY NSW	146.75	”	”

99114

CONTACT: TERRY McGRATH, PHONE: (03) 9611 5711.

Unclaimed Moneys Act 1962

Register of Unclaimed Moneys held by the —

<i>Name of Owner on Books and Last Known Address</i>	<i>Total Amount Due to Owner</i>	<i>Description Of Unclaimed Money</i>	<i>Date when Amount first became Payable</i>
COLONIAL FIRST STATE RETAIL PROPERTY TRUST			
	\$		
Est Henry Joshua Allen, 131 Esplanade, Henley Beach, SA	144.18	Cheque	23/05/97
Mrs Gwenyth Bernice Ballantyne, Unit 11, 5A Short Crescent, Beaumont, SA	108.00	”	”
Mr Mervyn Alwyn Collom, Unit 58, Mt Gravatt Retirement Village, 1748 Logan Road, Upper Mt Gravatt, Qld	309.53	”	21/11/97
Mr Barry Ferguson Cosier & Mr John A Knox, C/- Knox & Cosier Solicitors, P.O. Box 415, Lithgow, NSW	162.00	”	23/05/97
Mr Antony Crawford, C/- Palmers Chartered Accountants P.O. Box 7024, St. Kilda Road, Melbourne	115.42	”	”
Ltcol Charles Crawford, 59 Florentine Circuit, Kaleen, ACT	144.18	”	”
Ms Nicole Gaila Crawford, C/- Palmer & Partners, 10th Floor, 499 St Kilda Road, Melbourne	138.50	”	”
Design Roofing & Constructions Pty Ltd, “Superannuation Fund A/C” C/- Ernest & Young Registry, G.P.O. Box 505H, Melbourne	109.20	”	22/08/97
Design Roofing & Constructions Pty Ltd, “Superannuation Fund A/C”			

C/- Ernest & Young Registry, G.P.O. Box 505H, Melbourne Design Roofing & Constructions Pty Ltd, "Superannuation Fund A/C"	216.00	"	23/05/97
C/- Ernest & Young Registry, G.P.O. Box 505H, Melbourne	109.20	"	21/11/97
Mr Kenneth Lachlan Godfrey, 18 Normac Street, Roseville Chase, NSW	451.47	"	23/05/97
Mr Kenneth Lachlan Godfrey, 18 Normac Street, Roseville Chase, NSW	254.94	"	21/11/97
Mr Jeremy K. T. Lau & Mrs Charmaine Lau, 15 Whitewood Place, Caringbah, NSW	169.51	"	23/05/97
Mr Joseph Silbermann, C/- Silbermann Family Trust, 15-17 Captain Pipers Road, Vacluse, NSW	682.50	"	21/11/97
Estate Late Helen Stevens, C/- Coltmans Price Brent, G.P.O. Box 4941vv Melbourne	112.87	"	23/05/97
TPF& C Nominees Ltd, "Mercator Master Super Plan 30045 A/C", P.O. Box Q310			
Queen Victoria Building, Sydney, NSW	368.51	"	"
W. Newton Pty Limited, P.O. Box 418 Hill Street, Roseville, NSW	162.00	"	"
Weth Investments Pty Ltd, 200 Lygon Street, Carlton South	108.00	"	"
Mrs Annette Fay Woodford, 20 Fitzgerald St, Gatton, Qld	179.61	"	21/11/97

99115

CONTACT: TERRY McGRATH, PHONE: (03) 9611 5711.

Unclaimed Moneys Act 1962

Register of Unclaimed Moneys held by the —

<i>Name of Owner on Books and Last Known Address</i>	<i>Total Amount Due to Owner</i>	<i>Description Of Unclaimed Money</i>	<i>Date when Amount first became Payable</i>
CSL LIMITED			
	\$		
Dr Stephen Alexander C/- Alison Alexander, Unit 3, 352 Toorak Road, South Yarra	120.00	Cheque	20/11/97
Mr Ronald David Atterton & Ms Christine Anne Atterton, 24 Flaxman Street, Port Lincoln, SA	110.00	"	28/04/97
Mr Ronald David Atterton & Ms Christine Anne Atterton, 24 Flaxman Street, Port Lincoln, SA	200.00	"	20/11/97
Mrs Honor Chauvel Auchinleck, C/- Aitken Walker & Strachan 114 William Street, Melbourne	156.75	"	28/04/97
Mrs Honor Chauvel Auchinleck, C/- Aitken Walker & Strachan 114 William Street, Melbourne	285.00	"	20/11/97
Mr Robert Kerr Bailey & Mrs Patricia Ann Bailey, 110 Rue Basse 1180 Brussels (UCCLE), Belgium	500.00	"	"
Mr Andrew Leigh Baker, 32 Uvadale Grove, Kew	100.00	"	"
Bodalla Pastoral Company Pty Ltd, 14 Toorak Road, South Yarra	400.00	"	20/11/97

Ms Sylvia Boehm, 14 Sion Close, Waterford, WA	110.00	''	28/04/97
Estate Late Albert Brentnall, C/- State Trustees Ltd, GPO Box 1461n, Melbourne	110.00	''	''
Mr Peter Brooks & Mr Cameron Brooks, 13/50 Earle Street, Cremorne, NSW	100.00	''	20/11/97
Mr Peter John Martyn Burchill, 21 Cole St, Hawthorn East	100.00	''	''
Mr Harold William Cheeseman, 113b Seaforth Crescent, Seaforth, NSW	300.00	''	''
Ms Wai Ling Chiu, 6/38 Tramere Street, Drummoyne, NSW	300.00	''	''
Mrs Myrna Mary Campbell-Cowan, 6/35 Alfred Street, Kew	100.00	''	''
Fannie Bay Transport System Pty Ltd, P.O. Box 1737, Katherine, NT	200.00	''	''
Fannie Bay Transport System Pty Ltd, P.O. Box 1737, Katherine, NT	110.00	''	28/04/97
Mr Neil Alexander Firth, P.O. Box 9, Hahndorf, SA	100.00	''	20/11/97
Mrs Dulcie Josephine Flanagan, C/- M J Flanagan Oayley Newsagency, Frederick Street, Oatley, NSW	200.00	''	''
Mr Ernest Frederick, "Super Fund A/C" 244 Malvern Road, Prahran	165.00	''	28/04/97
Mr Ernest Frederick, "Super Fund A/C" 244 Malvern Road, Prahran	300.00	''	20/11/97
Mr Garry Clifford Gamlin & Mrs Cecilia Gamlin, 24 George Street, Heyfield	200.00	''	''
Mr Garry Clifford Gamlin & Mrs Cecilia Gamlin, 24 George Street, Heyfield	110.00	''	28/04/97
Gms Dhillon Pty Lt, "Super Fund A/C", 28 The Ridge, Canterbury	650.00	''	20/11/97
Mrs Elizabeth Harold, 150 Cecil Street, South Melbourne	110.00	''	28/04/97
Mr Benjamin Antony Holland, 2 Buley Street, East Hawthorn	100.00	''	20/11/97
Ms Lucy Katherine Hone, 3/149 Domain Road, South Yarra	100.00	''	''
Mrs Alice Juet-Lan Lee-Jiew, 7 Noojee Court, Yallambie	100.00	''	''
Mr Wai Fai Kan, 10 Second Avenue, Eastwood, NSW	1,050.00	''	''
Mr Wai Fai Kan, 10 Second Avenue, Eastwood, NSW	577.50	''	28/04/97
Mr Rowan John Kumar & Mrs Sonia Phoebe Kumar & Mr John Pennington Whiteman, 48 Martin Road, Glen Iris	100.00	''	20/11/97
Frank La Macchai, "Frank Lamacchia Family A/C" 17b Goldsmith Road, Spearwood, WA	250.00	''	''
Frank La Macchai, "Frank Lamacchia Family A/C" 17b Goldsmith Road, Spearwood, WA	137.50	''	28/04/97
Mr Lionel Egmont De Hochepped-Larpent, 21 Macey Street, Croydon	110.00	''	20/11/97
Mr Kok Tee Lim, C/- K P M G Peat Marwick, G.P.O. Box 2975ee, G.P.O. Melbourne	100.00	''	''
Ms Penelope Anne Maroudas, 15 Stanbury Way, Booragoon, WA	100.00	''	''
Mr Peter Andrew Martin, P.O. Box 93, Wee Waa, NSW	150.00	''	''
Mrs Barbara Morgan, P.O. Box 484, Nowra, NSW	137.50	''	28/04/97
Mr James Patrick O'Donohue, 28 Moffat Street, Brighton	110.00	''	''
Ord Superannuation Pty Ltd, 1st Floor 16 Ord Street, West Perth, WA	300.00	''	20/11/97
Mr Cosmos Papatsaras, "Papatsaras Family A/C", 16 Stephens Street, North Balwyn	120.00	''	''

Mr William Michael Poulton, 368 Fenlon Avenue, North Rockhampton, Qld	165.00	”	28/04/97
Mr Peter Pryles, C/- 2/377 Lonsdale Street, Melbourne	100.00	”	20/11/97
Mr John Redlich, Flat 3, 304 Dandenong Road, East St. Kilda	140.00	”	”
Reynolds Services Pty Ltd, 30 Glendarragh Rd, Templestowe	220.00	”	”
Mrs Giuseppina Catena Ruggiero, 94 Paramatta Road Double View, WA	100.00	”	”
Sabarka Pty Ltd, “D & C J Molloy Superfund A/C”, 1st Floor, Watkins Medical Centre, 225 Wickham Terrace, Brisbane, Qld	110.00	”	28/04/97
Mr Ian Graham Scott, “Andrew Boden Scott A/C”, 8 Curral Road, Elsternwick	100.00	”	20/11/97
Sjms Nominees Pty Ltd, 174 Phillip Street, Sydney, NSW	140.00	”	”
Ms Janice May Smart, 48 Martin Road, Glen Iris	100.00	”	”
Mr Sidney Edward Smith, 24 Woodend Road Ipswich, Qld	100.00	”	”
Stuart Andrew Pty Ltd, 113 Campaspe Esplanade, Echuca	159.50	”	28/04/97
Mr Michael Alan Stubbs, C/ Wealth Management Services, C/- William Noall Ltd, G.P.O. Box 4603SS Melbourne	200.00	”	20/11/97
Mr Eddie Wai-Kuen Tang & Ms Ngan Ling Tham 14 Glenda Street, Doncaster	247.50	”	28/04/97
Toplis And Harding Marine Pty Ltd, 45 The Boulevard, Heathmont	100.00	”	20/11/97
Mr Christopher John Trembearth, Flat 3/9 Burley Street Lane Cove, NSW	300.00	”	”
Mr Christopher John Trembearth, Flat 3/9 Burley Street Lane Cove, NSW	165.00	”	28/04/97
Vamiko Pty Ltd, 14 Darling Street, Bourke, NSW	110.00	”	”
Vamiko Pty Ltd, 14 Darling Street, Bourke, NSW	200.00	”	20/11/97
Ms Tania Viskovich, 15/76 Campbell Parade Bondi Beach, NSW	110.00	”	28/04/97
Ms Tania Viskovich, 15/76 Campbell Parade Bondi Beach, NSW	200.00	”	20/11/97
Mr Michael David Walton, 2 Mittabah Road, Hornsby, NSW	150.00	”	”
Mr Miles Daniel Webster, 1st Floor, 229 Rundle Street, Adelaide, SA	100.00	”	”
Mr Noel David Wendt, “Wendt Super Fund A/C”, 3 Candlebrook Quadrant, Rowville	100.00	”	”
Western Supply Co Pty Ltd, “Superannuation Fund A/C”, 52 Bond Street, Mordialloc	100.00	”	”
Ms Natalie Kaye Wild, “Orana Park”, Dingee	100.00	”	”
Mr Richard Woodgate, 163a Kitchener Rd, Alfred Cove, WA	100.00	”	”
Mr Christopher Liddon Wright, 31 Nantes Street, Newtown	100.00	”	”

99116

CONTACT: TERRY McGRATH, PHONE: (03) 9611 5711.

Unclaimed Moneys Act 1962

Register of Unclaimed Moneys held by the —

<i>Name of Owner on Books and Last Known Address</i>	<i>Total Amount Due to Owner</i>	<i>Description Of Unclaimed Money</i>	<i>Date when Amount first became Payable</i>
AMP GENERAL INSURANCE LIMITED			
\$			
Chin-Yuan Lin, 2/11 Glenview Road, East Doncaster	210.41	Cheque	05/01/98
Mr J. & Mrs J. Siriopoulos, 34 Prince Charles St., Clayton	100.00	"	07/01/98
Glaxo Wellcome Australia Ltd, 140 King Street, Melbourne	317.54	"	"
R.A. & C. M. Pretto, 87 Corowa Crescent, Greensborough	3,572.67	"	12/01/98
Nibonadis Pty Ltd, 491 Sydney Road, Brunswick	248.05	"	13/01/98
Phillip Elias t/as Total Panels, 12A Webster St., Dandenong	147.75	"	12/02/98
Microscene Computer Service P/L, C/- J. A. & L. Stanbury, 5 Chevron Court, Jan Juc	2,750.00	"	25/02/98
James & Diane McMaster, 39 Cole Street, Brighton	528.22	"	06/03/98
David & Christine Gray, 10 Osborne Street, Williamstown	215.99	"	11/03/98
Medegal Services, C/- Corrs Chambers Westgarth, G.P.O. Box 9925, Sydney, NSW	425.00	"	15/03/98
AON Professional Services, G.P.O. Box 4189, Sydney, NSW	754.70	"	24/03/98
B.A.S. 24 Hour Towing, 18 Abbey Road, Caboolture, Qld	295.00	"	"
Exclusive Mercantile Agency, G.P.O. Box 45A Melbourne	2,849.00	"	26/03/98
Peter & Pat Cleary & Patrad Pty Ltd, P.O. Box 233, Kew	700.00	"	"
KVM Constructions, 381 Tooronga Road, East Hawthorn	276.00	"	01/04/98
A. & D. Hodson, 34 Anderson Road, Armidale	178.28	"	07/04/98
Michael & Rosemary Dyer, C/- P.O. Box 1144G, Greythorn	180.36	"	15/04/98
Dryton, C/- Dr Hogan, 14 Wilson Avenue, Montmorency	325.00	"	16/04/98
R. S., S. E., S. R. Martin, 36 Blackburn, Stratford	400.00	"	20/04/98
B. MacDonald, 12 Coral Road, Mornington	168.00	"	"
D. F. & A. M. Dodd, 4 Sassella Street, South Oakleigh	190.00	"	22/04/98
Elite Fitness Equipment P/L, P.O. Box 925, Frankston	106.45	"	24/04/98
G. J. Denman, 26 Beaconsfield Road, Balmoral, NSW	270.73	"	14/04/98
Health Insurance Commission, 555 Lonsdale St., Melbourne	178.25	"	09/05/98
Theodorus Wijsman, 3 Pinewood Crescent, Wonga Park	135.77	"	11/05/98
Jonkar Industries Pty Ltd, P.O. Box 203, Bos Hill	833.33	"	14/05/98
Ray Jason, 19 Marriott Street, Caulfield	140.87	"	09/06/98
AON Professional Services, P.O. Box 4189, Sydney, NSW	516.76	"	16/06/98
P. & C. Curd, 1 Elmwood Crescent, Glen Waverley	106.85	"	18/06/98
Michelle Wallis, 222 Scott Street, Warracknabeal	1,250.00	"	23/06/98
Carrier Airconditioning P/L, A. & L. Dallas, 3/20 Chadstone Road, Chadstone	191.45	"	25/06/98
Mubkan Pty Ltd, 40 Forsythe Street, Banks, NSW	186.48	"	29/06/98
Australian Challenge Group, P.O. Box 221, Cheltenham	164.70	"	03/07/98
Salvation Army Westcare, Sedgwick Ltd, G.P.O. Box 1229L, Melbourne	180.00	"	03/07/98
Flora Hill Fibrous Plaster, 12 Hallam Street, Bendigo	350.00	"	15/07/98

Craig & Kayelene Hellyer, P.O. Box 380, Dromana	279.00	''	23/07/98
Hung Van Le	200.48	''	28/07/98
Julie Carol Courtis & David, 15/15 Peninsula Crescent, Langwarrin	272.19	''	''
Herbert Geer & Rundle, G.P.O. Box 524J, Melbourne	1,855.00	''	31/07/98
R. Iser & E. Lunn, 780 Lygon Street, Carlton North	137.84	''	04/08/98
R. C. & P. A. Wynn-Pope, 34 Boroondara Rd, Sorrento	460.00	''	05/08/98
D. T. & Y. Alexander	9,325.00	''	06/08/98
Sedgwick Ltd	472.33	''	10/08/98
S. Lopuszanski & s. Beales, 5 Percy Jones Court, Highton	118.93	''	19/08/98
P. & C. Freeman, 1/8 Wellington Crescent, East Melbourne	257.72	''	20/08/98
Vernon Packe, Flat 3, 76-78 Coolah Street, NSW	960.00	''	25/08/98
F. W. & J. A. Vanderkley P/L, 68 Stradbroke Rd, Montrose	350.00	''	28/08/98
P. & N. Ragusa, 1/30 Minerva Crescent, Keilor Downs	111.70	''	09/10/98
Melbourne Sport Depot, 9 Ashleigh Court,	190.00	''	''
N. Duong, 284 Hampshire Road, Sunshine	1,102.02	''	11/09/98
Martin Buckley, P.O. Box 286, Burwood	1,079.50	''	28/09/98
H. H., & J. I. Held, 6 Otira Road, Caulfield North	400.00	''	29/09/98
AON Risk Services, P.O. Box 7584,	1,357.22	''	07/10/98
R. F. Denham, & D, V, Ward, 3 Binda Court, Patterson Lakes	450.00	''	''
G. A. B. Robins, G.P.O. Box 215D, Melbourne	900.00	''	08/10/98
Kwik Kurry, Plaza Shopping Centre, Box Hill	450.00	''	13/10/98
David McLean Plumbing Services, 20 Langhorne Street, Dandenong	360.00	''	16/10/98
Gaslight Music, 85 Bourke Street, Melbourne	126.06	''	22/10/98
Sunrise Carpet Cleaning, 3/22A Fernhill Road, Sandringham	299.51	''	27/10/98
P. R. & A. F. Wilson, 56 Canterbury Road, Heathmont	317.34	''	29/10/98

00017

CONTACT: SIMONE IRELAND, PHONE: (02) 9257 2266.

Unclaimed Moneys Act 1962

Register of Unclaimed Moneys held by the —

<i>Name of Owner on Books and Last Known Address</i>	<i>Total Amount Due to Owner</i>	<i>Description Of Unclaimed Money</i>	<i>Date when Amount first became Payable</i>
ASHTON MINING LIMITED			
	\$		
Mr Leslie Walter Bunker C /-Perpetual Trustees Victoria Limited, 50 Queen Street, Melbourne	141.12	Cheque	22/04/97
Dr Choong Seng Chee, 323-B Thomson Road, Singapore 1130	192.00	''	''
Mr William Edward Coulston, 6 Karen Place, Ingleburn, NSW	131.16	''	''
Mr William Edward Coulston, 6 Karen Place, Ingleburn, NSW	131.16	''	30/09/97
G. P. Nominees Sdn Bhd, Level 2, Block F, North Damansara Town Centre, Damansara Heights 50490, Kuala Lumpur	322.38	''	''
G. P. Nominees Sdn Bhd, Level 2, Block F, North Damansara Town Centre, Damansara Heights 50490, Kuala Lumpur	322.38	''	22/04/97

M/S Vicki Ingham, Rmb 1239 Dairy Creek Road, Yea	126.00	”	30/09/97
Beng Kim Lim, 100 Howard Street, Rosalie, Qld	294.00	”	”
Mr Khui Loong, C/- Wing On Company Limited, 55 Leech Street, Ipoh Perak, West Malaysia	126.00	”	”
Mr Khui Loong, C/- Wing On Company Limited, 55 Leech Street, Ipoh Perak, West Malaysia	126.00	”	22/04/97
Patrick Harold McKenzie, 116 Kurrajong Street, Dorrigo, NSW	146.97	”	30/09/97
Millview Pty Limited, G.P.O. Box 7011, Sydney, NSW	150.00	”	22/04/97
Miss Amanda L. Muir Cheshunt, 102 Highfield Road, Camberwell	128.01	”	30/09/97
Miss Amanda L. Muir Cheshunt, 102 Highfield Road, Camberwell	128.01	”	22/04/97
Ong Nominees Private Limited, 76 Shenton Way, 06-00 Ong Building, Singapore 0207	640.50	”	30/09/97
P. Seng Pte Limited. 1 Chee Hoon Avenue, Singapore 299743	630.00	”	22/04/97
Miss Lee Yoke Ping, 21 Cecil Street, Kuala Lumpur, Malaysia	107.52	”	30/09/97
Thambo Ratnam, 91 Jalan Maarof Bangsar 59000 Kuala Lumpur, Malaysia	139.98	”	22/04/97
Thambo Ratnam, 91 Jalan Maarof Bangsar 59000 Kuala Lumpur, Malaysia	139.98	”	30/09/97

99118

CONTACT: TERRY McGRATH, PHONE: (03) 9611 5711.

Unclaimed Moneys Act 1962

Register of Unclaimed Moneys held by the —

<i>Name of Owner on Books and Last Known Address</i>	<i>Total Amount Due to Owner</i>	<i>Description Of Unclaimed Money</i>	<i>Date when Amount first became Payable</i>
NATIONAL MUTUAL HOLDINGS LIMITED			
\$			
Ms Claudia Mary Allen, 96 Lucerne Road, Remuera, Auckland 1005, New Zealand	188.00	Cheque	28/02/97
Ms Claudia Mary Allen, 96 Lucerne Road, Remuera, Auckland 1005, New Zealand	188.00	”	29/08/97
Ms Sarah Bernadette Allen, 6 Taurarua Terrace, Auckland, New Zealand	188.00	”	28/02/97
Mr Simon Christopher Allen, C/- P.O. Box 3464, Auckland, New Zealand	188.00	”	”
Mr Clifford Axelsen, 10 Fern Creek Road, Warriewood, NSW	118.36	”	”
British International Trading Pty Ltd, 97a Church Street, Castle Hill, NSW	347.24	”	”
British International Trading Pty Ltd, 97a Church Street, Castle Hill, NSW	347.24	”	29/08/97
Mr Robert Bruce Broadley 183 Montalbert Road Canterbury	703.40	”	”
Mr Heinz Randolph Burmeister, 44-46 Catalina Drv Tullamarine	685.20	”	”

Mr Heinz Randolph Burmeister, 44-46 Catalina Drv Tullamarine	685.20	''	28/02/97
Dale B. Elphinstone P/L, 4 Hopkinson St, Burnie, Tas.	383.12	''	29/08/97
Mr Michael Davidson, 5e/181 Exhibition Street, Melbourne	153.08	''	28/02/97
Mr Robert Anthony Eastham, 48 Parkwood Way, Traralgon	110.44	''	''
Mr Craig Elliott, 20 Howitt Street, Glen Iris	400.00	''	29/08/97
Miss Jacqueline Fallon, 51b Williton Rd, Karrinyup, WA	141.40	''	28/02/97
Miss Jacqueline Fallon, 51b Williton Rd, Karrinyup, WA	141.40	''	29/08/97
Mrs Rosslyn Fraser, 40 Beaconsfield Pde, Albert Park	189.20	''	28/02/97
Mr Alexander Ronald Hancock, 4 Woodland Loop, Edgewater, WA	171.16	''	29/08/97
Ms Maree Cathryn Harcourt, C/- 19 High Street, Trentham	160.00	''	''
Mrs Margaret Francis Hatch, 558 Horsley Drv, Smithfield, NSW	100.76	''	''
Mr Brian Andrew Hennessy, C/- Railway Quarters, Alpha, Qld	112.12	''	''
Mr D. T. Herbert, Carroboblin, Bedgerebong, NSW	113.56	''	''
Mr D. T. Herbert, Carroboblin, Bedgerebong, NSW	113.56	''	28/02/97
Ms Cheryl Kristen Hibble, Unit 8/36, Louisa Road, Birchgrove, NSW	120.00	''	''
Mr Allan Henry House, 17 Kenmare Ave, Berkeley Vale, NSW	188.28	''	''
Mr David John Iverson & Mr Barrie John Howard & Mr Paul William James, Messrs B. J. Howard, P. W. James & D. J. Iverson, P.O. Box 143, Wodonga	144.72	''	29/08/97
Mr Warren Ray Jodrell, P.O. Box 155, Woolgoolga, NSW	118.40	''	''
G. B. Jones, Manager G. B. Jones Pl, 135 Harbord Road, Harbord, NSW	106.56	''	28/02/97
G. B. Jones, Manager G. B. Jones Pl, 135 Harbord Road, Harbord, NSW	106.56	''	29/08/97
Mr Gordon Berkeley H. Jones, 135 Harbord Rd, Harbord, NSW	187.52	''	28/02/97
Mr Gordon Berkeley H. Jones, 135 Harbord Rd, Harbord, NSW	187.52	''	29/08/97
Mr John Anthony Joyce, 31 Argo Street, South Yarra	139.16	''	28/02/97
Mr Sam Katz, 63/2 Francis Street, Artarmon, NSW	117.88	''	29/08/97
Dr Muhammad Ayub Khan, P.O. Box 24e, Griffith, NSW	106.04	''	''
Dr Rao Irshad Mohammad Khan, 42 Hill St, Cabramatta, NSW	211.16	''	''
Mrs Zia-Ul Qamar Khan, 42 Hill Street, Cabramatta, NSW	211.16	''	''
Mrs Sheila Mary Lynch, 9 Griffith Ave, Coffs Harbour, NSW	161.56	''	''
Ms Christine Mansour, 31 Avon Court, Albany Creek, Qld	140.00	''	''
Mr Graham McLune & Mrs Wendy McLune, 5 Brandy Crt, Calamvale, Qld	127.48	''	28/02/97
Mr Graham McLune & Mrs Wendy McLune, 5 Brandy Crt, Calamvale, Qld	127.48	''	29/08/97
Mrs Wendy Anne McLune, Mr G. T. & Mrs W. A. McClune 5 Brandy Crt, Calamvale, Qld	181.20	''	28/02/97
Mr Paul James Mersch, 12 Jervois Street, Dianelle, WA	136.68	''	29/08/97
Mr Bryan Robert Molyneaux, 6 Centre Road, Carnegie	109.04	''	''
Mr Kerry Francis Mulhall, 151 Marmong St, Marmong Point, NSW	119.36	''	''
Mr Peter Nash & Mr David Nash, 7 Barbican Ct, Rowville	162.36	''	''
Ncr Superannuation Nominees Pty Ltd, 18-20 Napier Street, North Sydney, NSW	1,608.28	''	''
Mr David George Pettitt, Unit 55, Burns Beach C'van Park, Burns Beach Road, Iluka, WA	118.12	''	28/02/97
Dr Peter Laurence Randall, 14 Angelsea St, South Hobart, Tas.	112.84	''	29/08/97
Mr Kevin Garry Richardson, 121a Lookout Rd, New Lambton, NSW	164.12	''	''

J. Robertson & R. Robertson, 4 Burchill St, Loganholme, Qld	110.32	''	''
Mr Talbot Ian Rothwell & Mr Talbot Roy Rothwell, "Rothwell Super Fund A/C", 14 Blake Court, Mt Eliza	108.00	''	28/02/97
Mr Talbot Ian Rothwell & Mr Talbot Roy Rothwell, "Rothwell Super Fund A/C", 14 Blake Court, Mt Eliza	108.00	''	29/08/97
Mr Val Lewis Saxton, 666 Nepean Highway, Frankston	159.20	''	28/02/97
Sherlock Glen Pty Ltd, 359 High Street, Preston	125.76	''	''
Miss Jan Maree Smith, 3/2 Sandford St, St Lucia, Qld	240.16	''	28/02/97
Mr Fritz Sorensen & Mrs Christine Sorensen, 2/42 Palm Avenue, Holland Park, Qld	109.76	''	29/08/97
Mr Thomas Michael Stewart, 36 Lamerough Parade, Pelican Waters, Qld	121.84	''	''
Mr Donald James Swan, 2 Edinburgh Court, Pottsville Waters, NSW	149.40	''	28/02/97
Mr Alan Lyle Sweetman, 33-37 Roe, Street, Bridgetown, WA	122.76	''	''
Mrs Sim Seng Tan, C/- National Australia Bank, Logan Dist Comm Branch 59, 59 Kingston Road, Slacks Creek, Qld	440.00	''	''
Toorak Nominees Pty Ltd, 21 Bannister Rd, Canning Vale, WA	159.60	''	''
Mr John Stewart Tyson, 4 Irwin St, North Parramatta, NSW	132.72	''	''
Mr Constantine Vayanos, 43 Wisteria Crs, Mt Gravatt, East Qld	107.44	''	29/08/97
Mr David Michael Ward, 61 Brushwood Drv, Alfords Point, NSW	100.16	''	28/02/97
Mr David Michael Ward, 61 Brushwood Drv, Alfords Point, NSW	100.16	''	29/08/97
Mrs Heather May Whitson, P.O. Box 97, Mackay, Qld	296.72	''	''
Mrs Heather May Whitson, P.O. Box 97, Mackay, Qld	296.72	''	28/02/97
Mr Neil J. Whitson, P.O. Box 97, Mackay, Qld	149.16	''	''
Mr Neil J. Whitson, P.O. Box 97, Mackay, Qld	149.16	''	29/08/97
Dr Nasreen Taj Wilson, 54 Grand Junction Rd, Rosewater, SA	114.44	''	''
Miss Judith Lorraine Wisbey, 23 Clarke St, Thomastown	143.20	''	28/02/97

99121

CONTACT: TERRY McGRATH, PHONE: (03) 9611 5711.

Unclaimed Moneys Act 1962

Register of Unclaimed Moneys held by the —

<i>Name of Owner on Books and Last Known Address</i>	<i>Total Amount Due to Owner</i>	<i>Description Of Unclaimed Money</i>	<i>Date when Amount first became Payable</i>
RIO TINTO LIMITED			
\$			
Mrs Sophie Allegri, Rue De Langallerie 6 1003 Lausanne, Switzerland	414.70	Cheque	21/04/97
Mr Guy Mawson Allen, Mawsons Road Beerwah, Qld	155.84	''	''
Mr Leslie Frederick Amos, P.O. Box 104, Weipa, Qld	145.64	''	20/10/97
Mr Robert Norman Barnard, 8 Power St, Wavell Heights, Qld	445.33	''	21/04/97
Mrs Katharine Christine Batten, 33 Abbotsford Terrace, Devonport, Auckland, NZ	136.75	''	''

Mr Colin J. Bennett, 602 Melak Street, Karratha, Estate Late Marinus Boer, Populierestraat, 74 4431 Ck's-Gravenpolder, The Netherlands	381.84	''	''
Mr Michael Vincent Britt, 785 Glenferrie Road, Hawthorn	120.32	''	''
Mrs Durkje Petronella Brusse, 53 William Edward Street, Longueville, NSW	179.82	''	''
Mrs Durkje Petronella Brusse, 53 William Edward Street, Longueville, NSW	229.10	''	''
Mr Thomas Campbell, C/- Southern Copper Limited, PO Box 42, Port Kembla, NSW	116.51	''	20/10/97
Dr Sandra Mary Chalk, 201 Mackie Road, Clunes, NSW	238.87	''	''
Miss Helen Christopher, 15 Park Road, Montrose	477.30	''	''
Mrs Margaret Josie Clarke, 39 Poets Lane, Kalamunda, WA	143.41	''	''
Mrs Alice Hilda Clauson, C/-Corporate Registry Services Pty Ltd, G.P.O. Box 2975EE, Melbourne	355.18	''	''
Mr Bryan James Cleaver, C/- 24 Valley Way, Gynea Bay, NSW	407.79	''	''
Mr Bryan James Cleaver, C/- 24 Valley Way, Gynea Bay, NSW	381.84	''	21/04/97
Mr Bryan James Cleaver, C/- Minenco Pty Ltd, G.P.O. Box 5202aa, Melbourne	194.19	''	20/10/97
Mr Glen Alexander Clement, 34 Edward Street, Boyne Island, Qld	242.74	''	''
Mr Allan Edward Clifton, 20 Christie Court, Karratha, WA	194.19	''	''
Mr Francis Hugh Collingridge, C/-Computershare Registry Services Pty Ltd G.P.O. Box 2975EE, Melbourne	372.52	''	21/04/97
Mr Francis Hugh Collingridge, C/-Computershare Registry Services Pty Ltd G.P.O. Box 2975EE, Melbourne	189.45	''	20/10/97
Mr Nicholas A. Cooke, 265 Pickering Place, Walnut Creek, Cal 94598 USA	161.62	''	21/04/97
Mr Lucien Darre, C/- H. Cumines, 428 George Street, Sydney, NSW	206.02	''	''
Mr Lucien Darre, C/- H. Cumines, 428 George Street, Sydney, NSW	104.77	''	20/10/97
Dr Ronald Dight, C/- Taylor Bowring Pas, P.O. Box 748, West Perth, WA	124.19	''	''
Mr John Dixon, 7/120 Soi 6 Pongpet Village Changwattana, Bangkok, Thailand	106.56	''	21/04/97
Norma Kathleen Djismoen, Decd, C/- Harold C. Westall, P.O. Box 254, Crows Nest, NSW	120.32	''	''
Mr Robert Emerson Doane, C/- Day Cutten Ltd, G.P.O. Box 663, Adelaide, SA	198.70	''	20/10/97
Mr Robert Emerson Doane, C/- Day Cutten Ltd, G.P.O. Box 663, Adelaide, SA	390.72	''	21/04/97
Mr John Stephen Drummond, 42 Telegraph Rd, Pymble, NSW	159.84	''	''
Mrs Melinda Ann Dwight 3 Yeoman Court, Park Orchards E. G. & H. Nominees Pty Ltd, C/- Touche Ross Share Registry, G.P.O. Box 2975ee, Melbourne	444.00	''	''
E. G. & H. Nominees Pty Ltd, C/- Touche Ross Share Registry, G.P.O. Box 2975ee, Melbourne	129.84	''	20/10/97
E. G. & H. Nominees Pty Ltd, C/- Touche Ross Share Registry, G.P.O. Box 2975ee, Melbourne	255.30	''	21/04/97

M/s Mary Bannerman C. Ellis, C/- Bulbanna Administration Pty Ltd, P.O. Box 199 Carlton South	263.29	''	''
Endiford Pty Ltd, "Ben Katie A/C", 222 Stanley Terrace, Taringa, Qld	112.90	''	20/10/97
Mr Joseph Glen Fearon, C/- Morrison-Knudsen Railroad Div., P.O. Box 7808 Boise Idaho 83729 USA	157.62	''	21/04/97
Firth Engineering Co Pty Ltd, 4 Penrhyn Ave, Pymble, NSW	143.41	''	''
Mr Denis Patrick Fitzgibbons, 31a Berkeley Street, Speers Point, NSW	194.19	''	20/10/97
Dr Andrew Malcolm Flood, 11 Parkside Avenue, Balwyn	289.93	''	21/04/97
Miss Angela Cecilia Forster, P.O. Box 21, Mangrove Way, Somerset 9 Bermuda	532.21	''	20/10/97
Mr Richard Herbert Garnett, C/- Hudson Bay Mining & Smelting Co Ltd, P.O. Box 28, Toronto-Dominion Centre, Toronto M5K 1B8, Canada	143.41	''	21/04/97
Mr Ralph Cordner Gibson, 45 Alfred Street Heidelberg Heights Est Late Ethel Mary Goldberg,	175.38	''	''
C/- R. L. Wilkinson, P.O. Box 3001, Minnamurra, NSW	824.06	''	''
Miss Susan Goodman, 2 Phillip Street, Sydney, NSW	214.90	''	''
Mr Keith Battersby Gordon, C/- The Manager Bank of NSW, 111 Crown Street, Wollongong, NSW	194.92	''	''
Mr Christopher Jordan Gregory, Kotak Pos 7564/Cce J1 Cilandak Kko Jakarta Selatan 12075 Indonesia	477.30	''	''
Mr Christopher Jordan Gregory, Kotak Pos 7564/Cce J1 Cilandak Kko Jakarta Selatan 12075 Indonesia	242.74	''	20/10/97
Mrs Eileen Margaret Griffiths, 476 Morgan Street, Broken Hill, NSW 2880	175.82	''	21/04/97
Mr Robin Arthur Grigg, Barrosa Station, P.O. Box 4, Mt Somers, New Zealand	245.09	''	''
Miss Kathleen Elsie Gurling, 49 Thomas Street, Ringwood	242.74	''	20/10/97
Mr Graham William Guy, Unit 9, 3 Fulton St, Wishart, Qld	194.19	''	''
Miss Elizabeth Margaret Hall, 6 Electra Street, Willimstown	284.60	''	21/04/97
Miss Elizabeth Margaret Hall, 6 Electra Street, Willimstown	144.74	''	20/10/97
Mr Errol James Ernest Hanna & Mrs Jeanette Ann Hanna, PO Box 54128, Mana, Wellington, New Zealand	112.90	''	''
Mr David Hannah Jnr, St Helena, Armidale NSW	213.12	''	21/04/97
Mr David Hannah Jnr, St Helena, Armidale NSW	108.38	''	20/10/97
Mr Peter John Hannigan, 151 Grandview Rd, Pullenvale, Qld	143.41	''	21/04/97
Miss Leonie Margaret Horne, P.O. Box 160, Woodsode, SA	119.44	''	''
Miss Bridget Clare Hutchison, 35 Maning Ave, Sandy Bay, Tas.	121.48	''	20/10/97
Miss Bridget Clare Hutchison, 35 Maning Ave, Sandy Bay, Tas.	238.87	''	21/04/97
Ilepeach Pty Limited, C/- Economy Concrete Tanks Retirement Fund 1980, P.O. Box 317, Albury NSW	157.83	''	20/10/97
Mrs Beverley Raie Jamieson, P.O. Box 1200, Midland, WA	117.66	''	21/04/97
Mrs Marie Joy Johns, 5 Schev Street, Innisfail, Qld	301.92	''	''
Mrs Marie Joy Johns, 5 Schev Street, Innisfail, Qld	153.54	''	20/10/97
Mr Aylwin Frank Theodore Halligan-Jolly, 46 Queenscliffe Road, Doubleview, WA	147.41	''	21/04/97
Mr Bernard Kalb & Mrs Phyllis Kalb,			

6409 Danville Court, Rockville, Maryland 20852	150.07	''	''
Mr Bernard Kalb, 6409 Danville Court, Rockville, Maryland 20852 USA	211.34	''	''
Mr Bernard Kalb, 6409 Danville Court, Rockville, Maryland 20852 USA	107.48	''	20/10/97
Mr Wai Fai Kan, P.O. Box 506, Eastwood, NSW	121.48	''	''
Mr Wai Fai Kan, P.O. Box 506, Eastwood, NSW	238.87	''	21/04/97
Mr Loh Meen Kang, 44 Toh Tuck Road #03-05 Goodluck Garden, Singapore 2159	194.19	''	20/10/97
Mr Loh Meen Kang, 44 Toh Tuck Road #03-05 Goodluck Garden, Singapore 2159	381.84	''	21/04/97
Miss Muriel Grace Kierath, 123 Grosvenor Rd, Mt Lawley, WA	142.08	''	''
Laita Nominees Pty Ltd 1 Buchanan Road Altona North Est Late Lily Landy,	338.70	''	20/10/97
C/- Mr M Landy Moreland Fincance Corp (Vic), 591 Bridge Road, Richmond	146.96	''	21/04/97
Ms Clare Maria Lawrence, 4 Christowel Street, Camberwell	214.51	''	20/10/97
Mr Stephen Lewis 25 Phyllis Avenue Kanwal, NSW	477.30	''	21/04/97
LMr Laurence Robert Lockwood, Flat 8, 746 Beaufort Street, Mt Lawley, WA	205.57	''	''
Mr Laurence Robert Lockwood, Flat 8, 746 Beaufort Street, Mt Lawley, WA	104.55	''	20/10/97
Mr Kevin Richard Lynch, Villa 108, Banora Point Village, Leisure Drive, Banora Point, NSW	106.12	''	21/04/97
Mr John Butler MacGibbon, P.O. Box 13437, Christchurch, New Zealand	197.12	''	20/10/97
Mr John Butler MacGibbon, P.O. Box 13437, Christchurch, New Zealand	387.61	''	21/04/97
M. Mariyappa, C/- Miss M. Jayalakshmi J/56/1(Upstairs) Nanjegowda La Dodda Mavalli Bangalore 560004 Karnataka State, India	244.20	''	''
Mr Richard Alexander Matthews, P.O. Box 410, Kununurra, WA	381.84	''	''
Mr Richard Alexander Matthews, P.O. Box 410, Kununurra, WA	194.19	''	20/10/97
Mr Robert Evelyn Gurney Mayhew, La Vapora Guadiaro, Prov. de Cadiz, Spain	112.78	''	21/04/97
Miss Patricia Anne McDonagh, 11 Stanley St, Pascoe Vale South	127.87	''	''
Mr Anthony Robert McDonald, 1111 Jabbarup Place Tom Price, WA	143.41	''	''
Mr Graeme Douglas Edward McDonald & Ms Juliet Mavis Buist, "D. A. McDonald Family A/C", P.O. BOX 95, Arrowtown, New Zealand	242.74	''	20/10/97
Mr Peter Wilfred McGee & Estate Late Beryl Elizabeth Maude Berns, G.P.O. Box 3666, Sydney, NSW	121.48	''	''
Mr Robert Colin McIntosh, 62 Rockhampton Rd, Yeppoon, Qld	129.65	''	21/04/97
Mr Geoffrey Thomas McKay, Flat 2, 65 Weed Street, Manly, NSW	143.41	''	''
Millar Holdings Sdn Bhd, C/- The Liquidator Suite 100, 6th Floor, Wisma Yakin Jalan Masjid India, Kuala Lumpur, Malaysia 50100	171.83	''	20/10/97
Millar Holdings Sdn Bhd, C/- The Liquidator Suite 100, 6th Floor, Wisma Yakin Jalan Masjid India, Kuala Lumpur, Malaysia 50100	337.88	''	21/04/97

Noel Bennet Homes Pty Ltd, "Provident Fund A/C", P.O. Box 758, Tamworth, NSW	155.40	"	"
Mrs Tui Aroha Nourtier, C/- Sutton Apt 3a, 313 East 78th Street, New York NY 10021 USA	134.80	"	20/10/97
Mrs Tui Aroha Nourtier, C/- Sutton Apt 3a, 313 East 78th Street, New York NY 10021 USA	265.07	"	21/04/97
Mr Michael William Oley, Pt Keliiah Equatorial Mining, P.O. Box 269, Balikpapan Kalimantan Tihur, Indonesia	381.84	"	"
Mr Michael William Oley, Pt Keliiah Equatorial Mining, P.O. Box 269, Balikpapan Kalimantan Tihur, Indonesia	194.19	"	20/10/97
Mrs Mary Oliphant, 225 Wattletree Road, Malvern	238.87	"	21/04/97
Mrs Mary Oliphant, 225 Wattletree Road, Malvern	121.48	"	20/10/97
Mr Bernard Lewis O'Neil, 10 Square De La Tour Mauborg 75007, Paris, France	179.82	"	21/04/97
Pascrear Nominees (Vic) Pty Ltd, 44 Eleanor Street, Footscray	225.80	"	20/10/97
Mr George Edward Payne, 25 Bowen Street, New Farm, Qld Est Late Jack Gilbert Radford, C/- Mrs J. K. Radford, 8 Fernleigh Gardens, Rose Bay, NSW	109.67	"	21/04/97
Mr Barry Maxwell Ramsay, P.O. Box 325, Weipa, Qld	173.16	"	"
Mr Barry Maxwell Ramsay, P.O. Box 325, Weipa, Qld	381.84	"	"
Mr Barry Maxwell Ramsay, P.O. Box 325, Weipa, Qld	194.19	"	20/10/97
M/S Anna Jean Robson, 41 Waverley St, Shenton Park, WA	154.07	"	21/04/97
Mrs Helen Lyall Rollo, 203 Domain Road, South Yarra	160.28	"	"
Mr David William Rose, 62 Dickenson Way, Booragoon, WA	108.78	"	"
John Peter Dillon Rowley, Decd, C/- Rowlandson & Co, P.O. Box 275, Castle Hill, NSW	234.83	"	20/10/97
John Peter Dillon Rowley, Decd, C/- Rowlandson & Co, P.O. Box 275, Castle Hill, NSW	461.76	"	21/04/97
Mr Hiroshi Sato, 403 Dorufu 2-21-4 Tairamachi Meguroku, Tokyo, Japan	143.41	"	"
Mrs Shirley Ruth Scott, 51 Morella Avenue, Sefton, NSW	381.84	"	"
Mrs Shirley Ruth Scott, 51 Morella Avenue, Sefton, NSW	194.19	"	20/10/97
Mr Ami Chand Setu, P.O. Box 62, Emerald, Qld	105.67	"	"
Mr Ami Chand Setu, P.O. Box 62, Emerald, Qld	207.79	"	21/04/97
Shepperton Manor Pty Ltd, 419 Penshurst St, Roseville, NSW	166.06	"	"
Mr Vitorino Simoes, 16 Prince Street, Canley Vale NSW	182.22	"	20/10/97
Mr Vitorino Simoes, 16 Prince Street, Canley Vale NSW	358.31	"	21/04/97
Sixtyfirst Tostaree Pty Ltd, 28 Bailey Street, Bairnsdale	101.84	"	20/10/97
Sixtyfirst Tostaree Pty Ltd, 28 Bailey Street, Bairnsdale	200.24	"	21/04/97
Mrs Margaret Smith, Lot 3, Bryson's Road, Warranwood	117.66	"	"
Mr Jonathan David Sobels, C/- Morgan Stockbroking Ltd, G.P.O. Box 1846, Darwin, NT	132.76	"	"
SRB Nominees Pty Ltd, P.O. Box 495, South Yarra	238.22	"	20/10/97
Mr Ross Andrew Stevenson, 254 Yule Crescent, Dampier, WA	194.19	"	"
Mr Ross Andrew Stevenson, 254 Yule Crescent, Dampier, WA	381.84	"	21/04/97
Mr Lawrence Stokes, 15 Sorrett Avenue, Malvern	384.06	"	"
Mr Lawrence Stokes, 15 Sorrett Avenue, Malvern	195.32	"	20/10/97
Ranjit Singh Thind & Lalit Mehta, 16 Cumbrae Place, North Parramatta, NSW	381.84	"	21/04/97
Est Late Frank Turner, C/- E. R. Stack & Sons, P.O. Box 265, Forster, NSW	1,174.38	"	"
Est Late Frank Turner, C/- E. R. Stack & Sons, P.O. Box 265, Forster, NSW	597.24	"	20/10/97

Mr Johannes Jacobus Frederick Van Der Linden, C/- Karen Anthony, CRA Limited, 55 Collins St, Melbourne	477.30	''	21/04/97
Mr Johannes Jacobus Frederick Van Der Linden, C/- Karen Anthony, CRA Limited, 55 Collins St, Melbourne	242.74	''	20/10/97
Dr Raymond Crosbie Walsh, C/- Mr Peter Moore, 3 Beauchamp Avenue, Chatswood, NSW	166.06	''	21/04/97
Mr Paul Waua, P.O. Box 510, Panguna Nsp, Papua New Guinea	381.84	''	''
Mr Paul Waua, P.O. Box 510, Panguna Nsp, Papua New Guinea	194.19	''	20/10/97
Mr Forster Brian Weeks, P.O. Box 24-444 Royal Oak, Auckland, New Zealand	189.45	''	''
Mr Forster Brian Weeks, P.O. Box 24-444 Royal Oak, Auckland, New Zealand	372.52	''	21/04/97
Estate Late Flora Wilson, 14725-107a Avenue Surrey British Columbia, V3R 1V2 Canada	103.01	''	''
Mr Ian Boyd Wilson, P.O. Box 440, Weipa, Qld	477.30	''	''
Mr William Wilson, P.O. Box 61629 Houston, Texas 77208 USA	125.65	''	''
Mr Anthony Wada Winston, 87 Grange Road, Toorak	136.83	''	20/10/97
Mrs Fay Worner, 121 Windsor Street, Paddington, NSW	130.09	''	21/04/97
Mr Lam Shui Yuen, G/F 10 Briar Avenue, Happy Valley, Hong Kong	1,812.05	''	20/10/97
Mr Lam Shui Yuen, G/F 10 Briar Avenue, Happy Valley, Hong Kong	3,563.10	''	21/04/97

99122

CONTACT: TERRY McGRATH, PHONE: (03) 9611 5711.

Unclaimed Moneys Act 1962

Register of Unclaimed Moneys held by the —

<i>Name of Owner on Books and Last Known Address</i>	<i>Total Amount Due to Owner</i>	<i>Description Of Unclaimed Money</i>	<i>Date when Amount first became Payable</i>
NORTH LIMITED			
	\$		
Ms Janet Alexander, 44 Baal Street, Palmyra, WA	144.00	Cheque	30/09/97
Mr Mark Norman Anderson, 56 Stirling Street Byrnie, Tas.	148.80	''	11/03/97
Mr Mark Norman Anderson, 56 Stirling Street Byrnie, Tas.	334.80	''	30/09/97
Atmac Pty Ltd, 12th Floor, 55 Clarence Street, Sydney, NSW	270.00	''	''
Miss Margaret J. F. Bald, 4 Stonehouse Road, Newfield Rd 3, New York 14867 USA	171.04	''	11/03/97
Mr Emanuel Baldacchino, C/- Barclays Bank Plc, Piccadilly Circus Branch, 52 Regent St, London W1A 3BJ UK	734.40	''	30/09/97
Ms Nichola Anne Ball Lachlan, Vale Ouse, Tas.	420.56	''	11/03/97
M/s Marion P. Behsman, 86 Willmington St, Newmarket, Qld	135.00	''	30/09/97
Estate Late Peggy Aston Bould, C/- Public Trust, P.O. Box 31446, Lower Hutt, New Zealand	534.60	''	''
Est Late Myrtle Marion Bouquet, C/- Marsdens, P.O. Box 291, Campbelltown, NSW	140.76	''	''

Mr Scott A. Brancourt, 399 Hume Highway, Yargoona, NSW	194.40	''	''
John Briedis, "/C Practice Super Fund # 1", 28 President Avenue, Caringbah, NSW	192.00	''	11/03/97
Joyce Lilian Bryden-Brown, "Dalchroy", 99 Ducks Hill Road, Northwood, Middlesex HA6 2SQ UK	115.92	''	30/09/97
Jean Margaret Buxton, 106 Weld Street, Wadestown, Wellington, New Zealand	320.76	''	''
Jean Margaret Buxton, 106 Weld Street, Wadestown, Wellington, New Zealand	142.56	''	11/03/97
Mrs Gwenneth L. Cock, 79 Mary Street, Como, WA	103.68	''	30/09/97
Mrs Margaret F. Cordell, C/- Corporate Registry Services Pty Ltd, 12th Floor, 565 Bourke Street, Melbourne	181.44	''	''
Mrs Brenda Couldrey, C/- Mr H. W. Couldrey, P.O. Box 675, Auckland, New Zealand	143.73	''	''
Miss Lorna Cuthbertson, 5 Derwent Lane, Glebe, NSW	162.00	''	''
Mr Alan Andrew Davis & Mrs Nicola Brooke Davis, 10th Floor, 35 York Street, Sydney, NSW	142.56	''	''
Mr James W. G. Duncan, P.O. Box 28-016 Wellington 5, NZ	115.20	''	11/03/97
Mr James W. G. Duncan, P.O. Box 28-016 Wellington 5, NZ	259.20	''	30/09/97
Mrs Iris Edelman, 77 Cutler Road, Clontarf, NSW	302.40	''	''
Mrs Iris Edelman, 77 Cutler Road, Clontarf, NSW	134.40	''	11/03/97
Mrs Vera A. Fayat, 87 Avenue Des Rogations, Brussels 1200 Belgium	388.80	''	30/09/97
Mr Lou Thomas Ross Fitzgerald, 34 Gellibrand Street, Williamstown	1,350.00	''	''
Lesley Eleanor Fraser, 44 Hayhurst Street, Temuka, NZ	267.30	''	''
Lesley Eleanor Fraser & Colin David Fraser & Bruce Robert Fraser, C/- B. R. Fraser, P.O. Box 1509, Auckland, NZ	267.30	''	''
Lesley Eleanor Fraser & Colin David Fraser & Bruce Robert Fraser, C/- B. R. Fraser, P.O. Box 1509, Auckland, NZ	118.80	''	11/03/97
Ms Philippa Mary Frogg, 2944 Woodruff Drive, Smyrna, Georgia 30080 USA	155.61	''	30/09/97
Mr Paul Jeffrey Gale, 125 Halifax Road, Todmorden Lancashire 0414 5RE United Kingdom	120.00	''	11/03/97
Mr Paul Jeffrey Gale, 125 Halifax Road, Todmorden Lancashire 0414 5RE United Kingdom	270.00	''	30/09/97
Estate Late Margaret A. Giordano, 2 Kirby Court, West Hobart, Tas.	333.81	''	''
Elizabeth Claire Glendinning & Hugh Kenneth Glendinning & William Ross Jerram, C/- Mrs E. C. Glendinning Woodbrook R D 3 Waipukurau, Hawkes Bay, New Zealand	108.32	''	11/03/97
Mr Ian D. Gordon, 55 Kenmore Street, Newlands, Wellington, New Zealand	162.00	''	30/09/97
Janet Marjorie Hammond, 7 Campston Place, MacGregor, ACT Est Fanny N. Harding,	118.98	''	''
C/- Leddra Westmore & Co, P.O. Box 61, Mooroolbark	649.98	''	''
Mr Paul Sinclair Heithersay, C/- 476 St Kilda Rd, Melbourne Hermadi, Ciledug Raya Kemajuan Iv No 60 Jakarta Selatan, Indonesia 12270	450.00	''	''
Raymonde A. Hiatt, 34/297 Edgecliff Rd, Woollahra, NSW	180.00	''	''
Mr Robert W. P. Hiatt & Mr Stuart I. P. Hiatt, 4 Shaw Avenue, Kingsford, NSW	202.50	''	''
	122.40	''	11/03/97

Mr Robert W. P. Hiatt & Mr Stuart I. P. Hiatt, 4 Shaw Avenue, Kingsford, NSW	275.40	”	30/09/97
Mr William P. Hiatt, Unit 34, Victoria Gardens, 297 Edgecliff Road, Woollahra, NSW	113.16	”	11/03/97
Mr William P. Hiatt, Unit 34, Victoria Gardens, 297 Edgecliff Road, Woollahra, NSW	254.61	”	30/09/97
Dorothy E. Ingram, C/- ANZ Banking Company, 720 New South Head Road, Rose Bay, NSW	178.16	”	11/03/97
Eric Donald Jones, 2/12 McDonald Street, Cronulla, NSW	1,797.39	”	30/09/97
Eric Donald Jones, 2/12 McDonald Street, Cronulla, NSW	798.84	”	11/03/97
Kearney & Tyrrell Pty Ltd, 53 Rose Street, Essendon	270.00	”	30/09/97
Kearney & Tyrrell Pty Ltd, 53 Rose Street, Essendon	120.00	”	11/03/97
Mary M. Kenny, 15 Thornton Pde, Wavell Heights, Qld	151.02	”	30/09/97
Mr David Iain Robert Knowles, 301 Birdwood Terrace, Toowong, Qld	101.70	”	”
Ethel Maude Lawrence, Dec'd, “Tareelaro” Kurrajong, NSW	188.46	”	”
Mr Julio Lazo Inversiones, North Linitada, Chile, peru	180.00	”	”
Mrs Margaret M. Lee, 14 Arrunga Road, Arcadia, NSW	185.31	”	”
Mr Nicholas Edward Lorkovic, 17 Yarran Close, Edgeworth, NSW	270.00	”	”
Miss Julie N. MacDonald, P.O. Box 1078, Bournemouth, Dorset BH6 5YL U K	189.18	”	”
Marion Ferguson MacSwiney, 12 Onslow Gardens, London 10 3JU UK	882.81	”	”
Vijay Mansukhani, 26 Crespigny Foad Hendon Nw4, London, UK	123.57	”	”
Mareldor Investment Corporation Pty Ltd, 70 Kingsway, Nedlands, WA	162.00	”	”
Bernice Westwood McGregor, 8 Aratonga Ave, Greenlane, Auckland, NZ	103.68	”	”
Mr Angus Campbell McKechnie, 15/449 St Kilda Rd, Melbourne	181.08	”	”
Estate Late Alice Jane Morgan, C/- Linnells Greyfriars Court, Paradise Square, Oxford OXI 1BB United Kingdom	120.00	”	11/03/97
Estate Late Alice Jane Morgan, C/- Linnells Greyfriars Court, Paradise Square, Oxford OXI 1BB United Kingdom	270.00	”	30/09/97
Mr Stephen Gordon Morris, “Morris Family S/F A/C”, 43 Mungarie Street, Keperra, Qld	180.00	”	”
Estate Late Ian Philip Muston, C/- Garland Hawthorn Brahe, Level 6, 74 Castlereagh Street, Sydney, NSW	532.62	”	”
Estate Late Ian Philip Muston, C/- Garland Hawthorn Brahe, Level 6, 74 Castlereagh Street, Sydney, NSW	236.72	”	11/03/97
Est Joyce R. Nielsen C/- P. G. Symes & Co, 1st Floor, 202 Merrylands Road, Merrylands, NSW	315.00	”	30/09/97
Mrs Dora G. Norris, C/- The Public Trustee, G.P.O. Box 1565, Hobart, Tas.	124.74	”	”
Pauline B O’Kane, Dec’d, C/- Mr Norman B O’Kane And Mr John B O’Kane, 8 York Avenue, East Ivanhoe	159.57	”	”
Oral Support Pty Ltd “Hua & Rathsam Family A/C”, 6 Joseph Street, Lane Cove, NSW	282.60	”	”
Peko Services Ltd, C/- Computershare Registry Services G.P.O. Box 2975EE, Melbourne	594.00	”	”
Peko Services Ltd, C/- Computershare Registry Services G.P.O. Box 2975EE, Melbourne	264.00	”	11/03/97
Peko Wallsend Limited, “A/C T’tee” C/- Computershare Registry Services			

G.P.O. Box 2975EE, Melbourne	6,119.64	”	30/09/97
Peko Wallsend Limited, “A/C Tee” C/- Computershare Registry Services			
G.P.O. Box 2975EE, Melbourne	3,082.32	”	11/03/97
Alfred Isaac Phillips, “Ardmoray”, Methven Road, Whitecraigs, Glasgow, UK	256.50	”	30/09/97
Alfred Isaac Phillips, “Ardmoray”, Methven Road, Whitecraigs, Glasgow, UK	114.00	”	11/03/97
Mr Raymond G. Pivec, 428 Summerlin Avenue, Sanford, Florida 32771 USA	151.20	”	30/09/97
David Ritchie, P.O. Box 94, Annandale, NSW	143.68	”	11/03/97
Michael John Roberg, 16 Grandview Road, Glen Iris	107.28	”	30/09/97
Essie E. Roberts, Dec'd, C/- Mrs S. E. Coad, 15 Chakola Avenue, Hornsby Heights, NSW	673.74	”	”
Donald E. Rollason & William B. Phillips, C/- Rollason Davies & Liddell, G.P.O. Box 2590, Sydney, NSW	135.00	”	”
Mrs Jean H. Rose, C/-Corporate Registry Services Pty Ltd G.P.O. Box 2975EE, Melbourne	129.60	”	”
John W. M. Sanders, Little Valley No 5 R D Alexandra Central Otago, New Zealand	561.60	”	”
Mr Michael Joseph Scalzo, 1/18 Canberra Road, Toorak	166.50	”	”
Endah Sulistio Jl Nias Blok, 11/8 Villa Bintaro Regency Tangerang West Java, Indonesia 15226	180.00	”	”
Mrs Elizabeth J. H. Thompson, 110 Arabella Street, Longueville, NSW	769.50	”	”
Mr Keith G. Thompson, P.O. Box 245, Bowen, Qld	216.00	”	”
Sandra Christine Toohey, 622 O'Neill St, Broken Hill, NSW	120.00	”	11/03/97
Mr Douglas P. Wallace, 19 Victoria Street, Brighton	245.88	”	30/09/97
Mr Douglas P. Wallace, 19 Victoria Street, Brighton	109.28	”	11/03/97
Stephen James Walton, 21a Stove Court, Wickham, WA	180.00	”	30/09/97
Dean Elizabeth Watson, 110 Burnett Street, Hobart, Tas.	135.36	”	”
Peter Alexander Watt, 85 Trammere Road, Howrath, Tas.	103.68	”	”
Miss Elizabeth J. White, 6 Edward Street, Kew	162.72	”	”
Erwin Wilhelm & Inge Wilhelm, C/- C. Wilhelm, 215 Carmedy Road, St Luzia, Qld	108.00	”	”
Mrs Christine Isabel Williams, C/- Mr L. S. Williams M/S 1139 Pratts Road, Bakers Creek South Mackay, Qld	111.24	”	”

99124

CONTACT: TERRY McGRATH, PHONE: (03) 9611 5711.

Unclaimed Moneys Act 1962

Register of Unclaimed Moneys held by the —

<i>Name of Owner on Books and Last Known Address</i>	<i>Total Amount Due to Owner</i>	<i>Description Of Unclaimed Money</i>	<i>Date when Amount first became Payable</i>
AUSTRALIAN HOSPITAL CARE LTD			
	\$		
Mr Udi Epstein, 11 Gerard Street, Caulfield	112.50	Cheque	14/10/97
Mr Stanley Wai Hung Lah, Flat A 19/F 103 Broadway Street, Mei Foo Sun Chuen, Kowlan, Hong Kong	562.50	”	”

OCBC Asset Management Ltd, "OCBC Nominees 9015f A/C"			
OCBC Nominees Pte Ltd, #06-00 OCBC Centre, Singapore 049513	375.00	"	15/04/97
OCBC Asset Management Ltd, "OCBC Nominees 9016d A/C"			
OCBC Nominees Pte Ltd #06-00 OCBC Centre, Singapore 049513	187.50	"	"

99132

CONTACT: TERRY McGRATH, PHONE: (03) 9611 5711.

Unclaimed Moneys Act 1962

Register of Unclaimed Moneys held by the —

<i>Name of Owner on Books and Last Known Address</i>	<i>Total Amount Due to Owner</i>	<i>Description Of Unclaimed Money</i>	<i>Date when Amount first became Payable</i>
CENTRAL EQUITY LIMITED			
	\$		
Ms Linda Dickie, P.O. Box 7926, Gold Coast Mail Centre, Qld	120.00	Cheque	06/03/97
Ms Christine Hubay Harper, C/- Kutner Rosenberg, 8th Floor, 365 Queen Street, Melbourne	400.00	"	"
Mr Lawrence Ivan Hunter, 19 Spencer Road, Otamatata, NZ	210.00	"	30/09/97
Est Alan Lewis Langdon, C/- Bowen-Thomas & Barlow, P.O. Box 9, Gloucester, NSW	350.00	"	"
Ms Sarah Mitchell, 9 Bright Street, Ryde, NSW	200.00	"	06/03/97
Mr Simon Moskvina, 26 Gould Street, North Bondi, NSW	210.00	"	30/09/97
Mr Simon Moskvina, 26 Gould Street, North Bondi, NSW	120.00	"	06/03/97
Mr Alan Ward Naish & Mrs Florence Jane Naish, 25 Kakanui Road, RD 50, Oamaru, New Zealand	120.00	"	"
Mr Alan Ward Naish & Mrs Florence Jane Naish, 25 Kakanui Road, RD 50, Oamaru, New Zealand	210.00	"	30/09/97
Niece Investments Pty Limited, 72-80 Cooper Street Surry Hills, NSW	240.00	"	06/03/97
Niece Investments Pty Limited, 72-80 Cooper Street Surry Hills, NSW	420.00	"	30/09/97
Ms Betty Rose Stephens, C/-Corporate Registry Services Pty Ltd, G.P.O. Box 505H, Melbourne	126.00	"	"
Ms Sue Cong Swindells, P.O. Box 343, Glebe, NSW	101.96	"	06/03/97

99117

CONTACT: TERRY McGRATH, PHONE: (03) 9611 5711.

Unclaimed Moneys Act 1962

Register of Unclaimed Moneys held by the —

<i>Name of Owner on Books and Last Known Address</i>	<i>Total Amount Due to Owner</i>	<i>Description Of Unclaimed Money</i>	<i>Date when Amount first became Payable</i>
COLONIAL LIMITED (FIJI)			
	\$		
Mr Moti Lal Badan, P.O. Box 82, Nausori, Fiji	163.65	Cheque	30/01/98
Mrs Damyanti Ben, C/- Dominion Fashionwear Ltd P.O. Box 1444, Suva, Fiji	125.54	"	"
Dominion Fashionwear Ltd, P.O. Box 1444, Suva, Fiji	129.89	"	"
Maxlane Engineers, C/- Fiji Development Bank P.O. Box 104, Suva, Fiji	104.77	"	"
Mr Ruxmaniben Natwarlal Khatri, P O Box 39, Varoka Ba, Fiji	118.53	"	"
Mr Kava Tevite Konrote, P.O. Box 9824, Nadi, Fiji	304.00	"	"
Mr Joji Kotobalavu, Pm's Office, P.O. Box 2353, Govt. Bldgs, Suva, Fiji	132.14	"	"
Mrs Bena Krishna, P.O. Box 881, Lautoka, Fiji	163.93	"	"
Ms Suruj Kuari, P.O. Box 4276, Samabula Suva, Fiji	126.03	"	"
Mrs Renuka Devi Kumar & Mr Dhurup Kumar, P.O. Box 47, Ba Fiji, Fiji	108.42	"	"
Mr Jiua Matararaba, 82 Brown Street, Suva, Fiji	122.81	"	"
Mr Hirday Nath Pande, P.O. Box 1283, Suva, Fiji	174.81	"	"
Mrs Manjulaben Vinod Patel, P.O. Box 707, Ba, Fiji	116.07	"	"
Mrs Sunita Ben Umakant Patel, P.O. Box 707 Ba, Fiji	107.51	"	"
Mr Kafoa Ieli Pene, University of South Pacific, P.O. Box 1168, Suva, Fiji	133.19	"	"
Ram Padarath Brothers Limited, P.O. Box 47 Ba, Fiji	141.05	"	"
Mr Parshu Ram, 87 Cumming Street, Suva, Fiji	135.72	"	"
Mrs Chandra Girdhar Lal Raniga, P.O. Box 355, Nadi, Fiji	136.63	"	"
Mr Salesi Fililawa Savou, P.O. Box 15304, Suva, Fiji	115.23	"	"
Mr Deo Narayan Singh, P.O. Box 358, Nausori, Fiji	105.05	"	"
Mr Lion Kit Yee, P.O. Box 225, Labasa, Fiji	105.96	"	"
99213			
CONTACT: TERRY McGRATH, PHONE: (03) 9611 5711.			

Unclaimed Moneys Act 1962

Register of Unclaimed Moneys held by the —

<i>Name of Owner on Books and Last Known Address</i>	<i>Total Amount Due to Owner</i>	<i>Description Of Unclaimed Money</i>	<i>Date when Amount first became Payable</i>
COLONIAL LIMITED (NEW ZEALAND)			
	\$		
ANZ Bank Samoa Limited, P.O. Box 1855, Apia	224.95	Cheque	30/01/98
Ascon-Graphite NZ Limited, P.O. Box 58869, Greenmount, New Zealand 1730	236.51	"	"

Auto-Imprest Co Limited, P.O. Box 11465, Ellerslie New Zealand 1131	314.18	”	”
Beaney Holdings Limited, P.O. Box 65178, Mairangi Bay, New Zealand 1330	170.72	”	”
Mr Walter Patrick Colenso, 2-295 Cambridge Tce, Christchurch, New Zealand 8001	178.85	”	”
Cool-Az Ice Co Ltd, P.O. Box 331532, North Shore, New Zealand 1330	196.82	”	”
Dept Maori Affairs, 42 Tutanekei Street, Paraparaumu 6152, New Zealand	328.48	”	”
Fletcher & Woodward Limited, 13-15 Pukemiro Street, Onehunga, Auckland 1006, NZ	145.72	”	”
GNS Limited, P.O. Box 6838, Wellesley Street, New Zealand 1036	488.26	”	”
Mr Brendan Hegerty, 55 The Drive, Epsom, Auckland, NZ 1003	134.62	”	”
IDA Investments Limited, P.O. Box 3089, Auckland, New Zealand 1015	218.54	”	”
Mr Kenneth Windsor Knight, 60 Pah Road, Cockle Bay, Auckland, New Zealand 1704	126.42	”	”
Mr Bala Krishna & Mr Parmeshwar Latchmiah, 17 Seabrook Ave, New Lynn, Auckland, New Zealand 1007	113.92	”	”
Mr Mahesh Kumar & Mrs Taruna Kumar, C/- Belaire Dairy, 76 Rawhiti Road, Onehunga, Auckland, New Zealand 1006	178.15	”	”
Mr Peter James Leslie, 6 Hillsdale Road, Hillsborough, Auckland, New Zealand 1004	120.40	”	”
Mr Suriya Narayan & Mr Ram Chandra, 17 Seabrook Ave, New Lynn, Auckland, New Zealand 1007	145.56	”	”
National Leasing & Vending Machine Co Limited, P.O. Box 99055 Newmarket 1031, New Zealand	464.51	”	”
Mr David Tanton Nichols, 36 Rajkot Tce, Broadmeadows, Wellington, New Zealand 6004	133.14	”	”
Derek Oscar Owles, 34 Avon Avenue, Banksia Beach, Qld	165.88	”	”
Mr Ishwar Lal Patel & Mr Ashok Kumar Patel, P.O. Box 57032, Owairaka, Auckland 1030, New Zealand	204.55	”	”
Mr Darcy Phillips, P.O. Box 76, Owhango, New Zealand 2656	171.58	”	”
Princely Investments Limited, P.O. Box 65178, Mairangi Bay, New Zealand 1330	312.69	”	”
Provide-A-Dive Ltd, P.O. Box 18238, Glen Innes, New Zealand 1130	277.61	”	”
Quikclean Laundries Limited, P.O. Box 51545, Pakuranga, New Zealand 1730	260.34	”	”
Reid & Twiname Ltd. C/- Colonial Pid, P.O. Box 191, Wellington, New Zealand 6015	140.80	”	”
Rowell Contractors Limited, P.O. Box 38208, Wellington, New Zealand 6332	242.68	”	”
Mr Brian Gordon Setford, 13 Runciman Pl, Dannevirke, New Zealand 5491	129.23	”	”
Mrs M. J. Smith, P.O. Box 675, Invercargill, New Zealand 9515	227.14	”	”
Mr Erik John C. Terrell & Mrs Jenyfer Mary Terrell, 6 Spencer Street, Remuera, Auckland, New Zealand 1005	150.56	”	”
Tisco Limited, “Superannuation Fund A/C”, P.O. Box 44-163, Auckland 1030, New Zealand	1,120.21	”	”
Kevin Morell Westmoreland, Westmead Hokio Sands Road, R D 1, Levin 5500, New Zealand	180.10	”	”
Allan Rex Williams, 2/62 Fortune Street, Mairehau, Christchurch 8005, New Zealand	216.98	”	”

99214

CONTACT: TERRY McGRATH, PHONE: (03) 9611 5711.

Unclaimed Moneys Act 1962

Register of Unclaimed Moneys held by the —

<i>Name of Owner on Books and Last Known Address</i>	<i>Total Amount Due to Owner</i>	<i>Description Of Unclaimed Money</i>	<i>Date when Amount first became Payable</i>
CHINA PROSPERITY INTERNATIONAL HOLDINGS LIMITED			
\$			
Mr Arul Anandam, 3 Market Street, Nunawading	111.00	Cheque	14/05/97
Eddington Pty Ltd, C/- Level 29, 459 Collins St, Melbourne	350.00	"	17/10/97
Eddington Pty Ltd, C/- Level 29, 459 Collins St, Melbourne	444.00	"	14/05/97
Ms Gui Qin Fang, 5/27 Windella Avenue, Kew East	119.88	"	"
Mr Greg Fuller, Unit 8, 39 Walpole Street, Kew	111.00	"	"
Mr Gregory John Charles Fuller, 8/39 Walpole Street, Kew	111.00	"	"
Mr John Nicolis C/- Salomon Brothers Asia Ltd, Urbannet Ohtemachi Building, 2-2 Ohtemachi 2 Chome Chiyoda-Ku, Tokyo 100, Japan	350.00	"	17/10/97
Mr John Nicolis C/- Salomon Brothers Asia Ltd, Urbannet Ohtemachi Building,S 2-2 Ohtemachi 2 Chome Chiyoda-Ku, Tokyo 100, Japan	444.00	"	14/05/97
Mr Roger David Spalding, 3/283 South Terrace, Adelaide, SA	222.00	"	"

99216

CONTACT: TERRY McGRATH, PHONE: (03) 9611 5711.

Unclaimed Moneys Act 1962

Register of Unclaimed Moneys held by the —

<i>Name of Owner on Books and Last Known Address</i>	<i>Total Amount Due to Owner</i>	<i>Description Of Unclaimed Money</i>	<i>Date when Amount first became Payable</i>
TOLL HOLDINGS LIMITED			
\$			
Mr David Alexander Alt, 19 Bayswater Road, Lindfield NSW	150.00	Cheque	06/10/97

99033

CONTACT: TERRY McGRATH, PHONE: (03) 9611 5711.

PROCLAMATIONS

ACTS OF PARLIAMENT

Proclamation

I, James Gobbo, Governor of Victoria, declare that I have today assented in Her Majesty's name to the following Bills:

No. 5/2000 **First Home Owner Grant Act 2000**

No. 6/2000 **National Taxation Reform (Consequential Provisions) Act 2000**

Given under my hand and the seal of Victoria at Melbourne on 11 April 2000.

(L.S.) JAMES GOBBO
Governor of Victoria
By His Excellency's Command
STEVE BRACKS
Premier

This Proclamation is effective from the date on which it is published in the Government Gazette.

Given under my hand and the seal of Victoria on 11 April 2000.

(L.S.) JAMES GOBBO
Governor

By His Excellency's Command

SHERRYL GARBUTT MP
Minister for Environment and Conservation

No. 5/2000 This Act comes into operation on 1 July 2000.

No. 6/2000 (1) This Act, except Parts 8 and 9 and sections 17, 18, 19, 24, 33 and 34, comes into operation on the day after the day on which it receives the Royal Assent.

(2) Section 31 is deemed to have come into operation on 17 February 1999.

(3) The remaining provisions of Part 9 and sections 17, 18, 19, 24, 33 and 34 come into operation on 1 July 2000.

(4) Part 8 comes into operation on 3 July 2000.

Land Act 1958

PROCLAMATION OF ROAD

I, James Gobbo, Governor of Victoria acting with the advice of the Executive Council and under section 25(3)(c) of the **Land Act 1958** proclaim as road the following land:

MUNICIPAL DISTRICT OF THE
GREATER BENDIGO CITY COUNCIL

ELLESMERE — Crown Allotment 89G, No Section, Parish of Ellesmere as shown on Original Plan No. 120208 lodged in the Central Plan Office. — (L6-10443).

**GOVERNMENT AND OUTER BUDGET SECTOR AGENCIES
NOTICES**

**CITY OF WHITEHORSE
Road Discontinuance**

Under Section 206 and Schedule 10 Clause 3 of the **Local Government Act 1989** the Whitehorse City Council at its meeting held on Monday 3 April 2000 formed the opinion that the road shown on the plan below is not reasonably required as a road for public use and resolved to discontinue the road shown hatched and to sell the land from the road to abutting owners, subject to any right, power or interest held by Yarra Valley Water and Whitehorse City Council in the road in connection with any sewers, drains or pipes under the control of those authorities in or near the road.

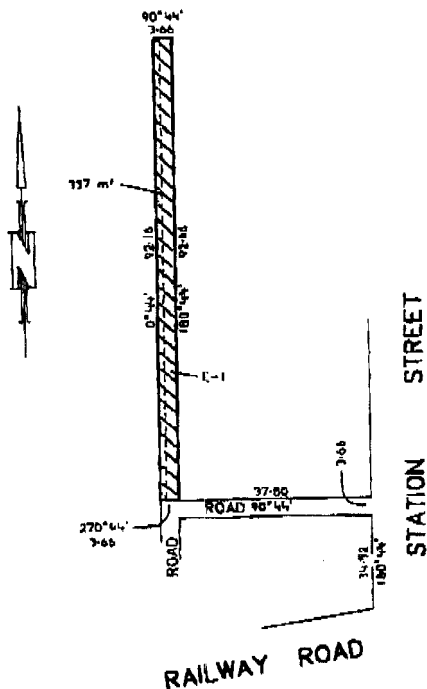

STEPHEN WRIGHT
Acting Chief Executive Officer

**GLEN EIRA CITY COUNCIL
Road Discontinuance**

Pursuant to section 206 and schedule 10, clause 3 of the **Local Government Act 1989**, the Glen Eira City Council has formed the opinion that the road at the rear of 18 to 26 South Avenue and 13 to 23 Barry Street,

Bentleigh, and shown by hatching on the plan below, is not reasonably required as a road for public use and has resolved to discontinue the road and to sell the land from the road to the abutting property owners, subject to the right, power or interest held by South East Water Limited in the road in connection with any sewers, drains or pipes under the control of that authority in or near the road.

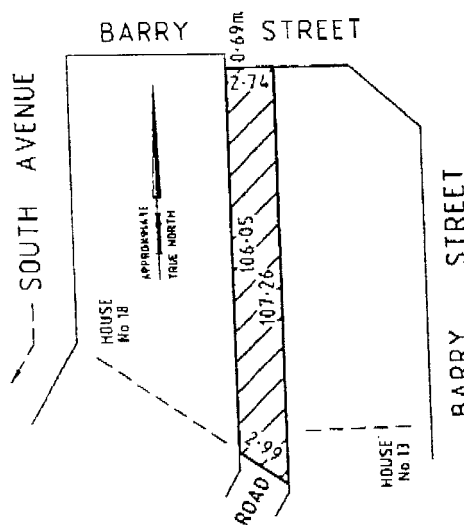

ANDREW NEWTON
Acting Chief Executive Officer



**PUBLIC NOTICE –
ADOPTION OF LOCAL LAW NO. 4
Consumption of Alcohol in Public Places**

Yarriambiack Shire Council would like to give public notice that the Consumption of Liquor in Public Places Local Law has been made and adopted in accordance with provisions of Section 111 of the **Local Government Act 1989**.

The title of the local law is Consumption of Liquor in Public Places.

The purpose of the local law is to:

- (1) Provide for the peace, order and good government of the municipal district of the Council.
- (2) Regulate and control the consumption of alcohol in designated public areas within the municipality.
- (3) Protect against behaviour which causes or is likely to cause offence or nuisance or detriment to the amenity and environment.
- (4) Protect the community interest.

A copy of the proposed local law can be obtained from Council offices in Warracknabeal, Hopetoun or Rupanyup.

For further information please contact Council's Environmental Health/Local Laws Officer, Simon Coutts on 5398 0171.

JENNIFER A. TOD
Chief Executive Officer



NOTICE OF PROPOSAL
Meeting Procedure Local Law

Notice is hereby given that the Nillumbik Shire Council (the Council) proposes to repeal Local Law No. 3 (Meeting Procedure) and replace it by making a new Local Law No. 4, Meeting Procedure, under Section 111 of the **Local Government Act 1989** for the purpose of:

- (a) regulating the use of the common seal;
- (b) prohibiting unauthorised use of the common seal or any device resembling the common seal;
- (c) regulating proceedings for the election of the mayor and chairpersons of various committees; and
- (d) regulating proceedings at Council Meetings, Special Committee Meetings and other meetings conducted by or on behalf of Council where Council has resolved that the provisions of this Local Law are to apply.

A copy of the proposed Local Law may be inspected at or obtained from the Shire Offices, Civic Drive, Greensborough during office hours.

Any person affected by the proposed Local Law may make a submission relating thereto to the Council. Submissions received by the Council within 14 days of the publication of this notice will be considered in accordance with Section 223 of the **Local Government Act 1989**.

Any person requesting that he or she be heard in support of a written submission is entitled to appear before a meeting of the Council or Council Committee either personally or by a person acting on his or her behalf and will be notified of the time, date and place of the hearing.

Submissions marked Meeting Procedure Local Law should be posted to the Chief Executive Officer, P.O. Box 476, Greensborough 3088 or delivered to the Shire Offices, Civic Drive, Greensborough. Telephone enquiries concerning the proposed Local Law should be directed to Geoff Ferguson on 9433 3284.

CATHERINE DALE
Chief Executive Officer



Notice is given that at a meeting of Casey City Council held on 4 April 2000, Council resolved to make Local Law No. 15 – Meeting Procedures and Use of the Common Seal (Amendment No. 1 of 2000) Local Law pursuant to the **Local Government Act 1989** (the Act).

The purpose of the Local Law is set out as follows:

- A. Amending Local Law No. 1 – Meeting Procedures and Use of the Common Seal Local Law;
- B. Regulating the conduct of meetings of Council, as required by Section 91(1) of the Act;
- C. Regulating and controlling the procedures regarding the conduct of meetings of Council; and
- D. Providing for the administration of Council powers and functions.

The general purport of the Local Law is that it:

- Provides for order of business at Ordinary Council Meetings;
- Provides for reports by Council Delegates at Council Meetings;
- Amends the procedure for dealing with motions and amendments;
- Amends the circumstances in dealing with correspondence, joint letters and petitions;
- Provides for a number of minor procedural amendments to Local Law No. 1.

A copy of the Local Law may be inspected at the Municipal Offices, 340-350 Princes Highway, Narre Warren or at the Customer Service Centre, 156-160 Sladen Street, Cranbourne.

MIKE TYLER
Chief Executive Officer

Planning and Environment Act 1987

CASEY PLANNING SCHEME

Notice of Amendment

Amendment C9

The land affected by the Amendment is Municipal Reserve (Nos. 106-108) Strathaird Drive, Narre Warren South; Nos. 1-6 Len Thomas Place, Narre Warren and No. 5 New Holland Drive, Cranbourne.

The Amendment proposes to rezone Municipal Reserve (Nos. 106-108) Strathaird Drive, Narre Warren South, from a Public Use Zone (Local Government) & Residential 1 Zone to a Public Park and Recreation Zone, which will facilitate the land to be used and developed as a recreational facility; rezone Nos. 1-6 Len Thomas Place, Narre Warren from a Public Use Zone (Local Government) to an Industrial 1 Zone, which will facilitate the land to be used and developed for industrial purposes and rezone No. 5 New Holland Drive, Cranbourne from a Public Use Zone (Local Government) to a Public Use Zone (Education), which will facilitate the establishment of a special school.

The person who requested the Amendment is the City of Casey.

You may inspect the amendment, and any documents that support the amendment and the explanatory report about the amendment at the office of the planning authority: Casey City Council, Municipal Offices, Princes Highway,

Narre Warren; Casey City Council, Customer Service Centre, Sladen Street, Cranbourne and at Department of Infrastructure, Customer Service Centre, Nauru House, 80 Collins Street, Melbourne.

This can be done during office hours and is free of charge.

Any person who may be affected by the Amendment may make a submission to the planning authority.

The closing date for submissions is 15 May 2000.

A submission must be sent to: The Manager Planning, Casey City Council, Municipal Offices, P.O. Box 1000, Narre Warren 3805.

Should you have any queries about this matter, please contact Frank Mangan on 9705 5264.

JACQUI HOUGUET
Manager Planning

Planning and Environment Act 1987

CASEY PLANNING SCHEME

Notice of Amendment

Amendment C15

The land affected by the Amendment is Lot 1, LP 117455, (Nos. 147-161) Harkaway Road, Harkaway.

The Amendment proposes to include a site specific provision in the Casey Planning Scheme, which will facilitate the subdivision of the land into two lots, generally in accordance with a specified plan. The lots will be about 4 and 5 hectares in area and will contain an existing dwelling.

The person who requested the Amendment is the KLM Consulting Group, acting for Nevada Nominees Pty Ltd and Mrs Kay Glendenning.

You may inspect the amendment, and any documents that support the amendment, and the explanatory report about the amendment, at the office of the planning authority: Casey City Council, Municipal Offices, Princes Highway, Narre Warren; and at: Department of Infrastructure, Customer Service Centre, Nauru House, 80 Collins Street, Melbourne.

This can be done during office hours and is free of charge.

Any person who may be affected by the Amendment may make a submission to the planning authority.

The closing date for submissions is 15 May 2000.

A submission must be sent to: The Manager Planning, Casey City Council, Municipal Offices, P.O. Box 1000, Narre Warren 3805.

Should you have any queries about this matter, please contact Frank Mangan on 9705 5264.

JACQUI HOUGUET
Manager Planning

Planning and Environment Act 1987

CASEY PLANNING SCHEME

Notice of Preparation of an Amendment

Notice of an Application for Planning Permit

Amendment C17

Application P10/00

The land affected by the Amendment is: Lots 55, 56 & 57, PS 423792D, (Nos. 25, 27 & 29) Hartley Link, Endeavour Hills and part of Reserve No. 1, PS 423792D, Hartley Link, Endeavour Hills.

The land affected by the application is: Lots 55, 56 & 57, PS 423792D, (Nos. 25, 27 & 29) Hartley Link, Endeavour Hills.

The Amendment proposes to rezone the land from a Residential 1 zone to a Business 1 Zone under the Casey Planning Scheme.

The application is for a permit to construct 8 shops and associated car spaces. These shops would extend the existing "The Terrace" convenience centre. The access for the extended Convenience Centre would be from Raymond McMahon Boulevard. The application also includes some car spaces in and a pedestrian connection to Hartley Link.

The person who requested the Amendment and the applicant for the permit is: Taylors, on behalf of Nicholls Gledhill.

You may inspect the amendment and the application, and any documents that support the amendment and application, and the explanatory report about the amendment and application at the office of the planning authority: Casey City Council, Municipal Offices, Princes Highway, Narre Warren and at: Department of

Infrastructure, Customer Service Centre, Nauru House, 80 Collins Street, Melbourne.

This can be done during office hours and is free of charge.

Any person who may be affected by the Amendment or by the granting of the permit may make a submission to the planning authority.

The closing date for submissions is 15 May 2000.

A submission must be sent to: The Manager Planning, Casey City Council, Municipal Offices, P.O. Box 1000, Narre Warren 3805.

Should you have any queries about this matter, please contact Frank Mangan on 9705 5264.

JACQUI HOUGUET
Manager Planning

Planning and Environment Act 1987

MOYNE PLANNING SCHEME

Notice of Amendment

Amendment C1

Moyne Shire Council has prepared Amendment C1 to the Moyne Planning Scheme.

The purpose of the Amendment is to effect Map changes to facilitate the rezoning of Public Use zoned land to Residential 1 and to introduce an Environmental Audit Overlay.

The Amendment affects two parcels of land described as: -

1. Northwest corner of Cox Street and Princes Street, Port Fairy. Lots 7 & 8 on Plan of Subdivision, Cox Street, Port Fairy, described as Lots 7 & 8, on Plan of Subdivision, Block 5, being part of Atkinsons Crown Special Survey, Town and Parish of Belfast, Vol. 3373, Fol. 408, (Former Belfast Shire Land).
2. Bowls Court, Port Fairy, described as the land remaining in unconveyed Deed 581, Book 499, being Part Block 7, Town of Port Fairy, Parish of Belfast, Deed 299, Book 673, being Part of Block 7, Town of Port Fairy, Parish of Belfast and Certificates of Title Vol. 8073 Fol. 220, Vol. 8396, Fol. 822, (Former Borough of Port Fairy Depot).

The Amendment can be inspected at: -

1. The Office of the Moyne Shire Council, Princes Street, Port Fairy.

2. The Melbourne Office of the Department of Infrastructure, Level 14, Nauru House, 80 Collins Street, Melbourne.
3. The Geelong Office of the Department of Infrastructure, 63 McKillop Street, Geelong.

Submissions about the Amendment must be sent to the Moyne Shire Council, P.O. Box 51, Port Fairy, by Monday, 12 May 2000.

Dated 4 April 2000.

PETER REEVE
Director Services & Planning

Planning and Environment Act 1987

COLAC OTWAY PLANNING SCHEME

Notice of Amendment

Amendment C5

The Colac Otway Shire Council has prepared Amendment C5 to the Colac Otway Planning Scheme.

Land affected by the amendment

The amendment relates to four small parcels of land in the Barwon Downs/Gerangamete area. The four parcels of land are affected by rezoning and overlay amendment.

The amendment proposes to: Amend the planning scheme map No. 16, to change the existing Rural Zone to part Public Use Zone and part Rural Zone on four parcels of land described on the attached plans. Amend the Public Acquisition Overlay on Map No. 16PAO to include the same four parcels of land as detailed above in the overlay. Correction of planning scheme Map No. 16 to change the existing Rural Zone to Public Use Zone to reflect the current land ownership and use.

The amendment can be inspected at: Colac Otway Shire Offices, Rae Street, Colac; Colac Otway Shire, Customer Service Centre, Nelson Street, Apollo Bay; Department of Infrastructure, Upper Plaza, Nauru House, 80 Collins Street, Melbourne and Department of Infrastructure, 63 McKillop Street, Geelong.

Submissions about the amendment must be sent to: Mr. Glenn Patterson, Chief Executive Officer, Colac Otway Shire Council, P.O. Box 283, Colac, Vic. 3250

Submissions must be received by 14th May 2000.

GLENN A. PATTERSON,
Chief Executive Officer

Planning and Environment Act 1987

WHITTLESEA PLANNING SCHEME

Notice of Amendment

Amendment C6

The City of Whittlesea has prepared Amendment C6 to the Whittlesea Planning Scheme.

The amendment applies to approximately 1.28 hectares of land on the north side of Cooper Street, Epping approximately 170 metres north east of the Merri Creek (which forms the municipal boundary with the City of Hume). The land is owned by the City of Whittlesea.

The amendment proposes to change the Whittlesea Planning Scheme by: Rezoning the above parcel of land from "Special Use Zone 4 – Extractive Industry" to "Public Use Zone 6 – Local Government".

The amendment will facilitate the use and development of the land for a municipal animal pound in accordance with plans to be approved by Council following consultation with the Merri Creek Management Committee.

The amendment can be inspected free of charge during office hours at: Department of Infrastructure, Customer Service Centre, Upper Plaza, Nauru House, 80 Collins Street, Melbourne 3000 and City of Whittlesea, Planning Services Department, Civic Centre, Ferres Boulevard, South Morang 3752.

Submissions to the amendment must be sent to: The Chief Executive Officer, City of Whittlesea, Locked Bag 1, Bundoora MDC 3083 by Tuesday 16 May 2000.

GRAEME BRENNAN
Chief Executive Officer

ERRATUM

This notice replaces the notice on page 646 of Government Gazette G14 dated 6 April 2000.

Planning and Environment Act 1987

KINGSTON PLANNING SCHEME

Notice of Amendment

Amendment C6

The City of Kingston has prepared Amendment C6 to the Kingston Planning Scheme.

The Amendment affects Boundary Road between Centre Dandenong Road and Kingston

Road, and land known as Crown Allotments 2 and 3E, Boundary Road, Dingley Village.

The Amendment:

- changes the zoning of part of Boundary Road, between Centre Dandenong Road and Kingston Road, from Rural Zone – Schedule 2 to Road Zone Category 1;
- modifies the Public Acquisition Overlay – Schedule 1 on the eastern side of Boundary Road, Centre Dandenong Road and Junction Road.

A copy of the Amendment can be inspected, free of charge, during office hours, at: Department of Infrastructure, Customer Service Centre, Upper Plaza, Nauru House, 80 Collins Street, Melbourne; Kingston City Council – Mentone Offices, corner Mentone Parade and Brindisi Street, Mentone 3194 and Kingston City Council – Moorabbin Offices, 999 Nepean Highway, Moorabbin 3189.

Submissions about the Amendment must be sent to: The Chief Executive Officer, City of Kingston, P.O. Box 1000, Mentone 3194 by 5.00 p.m. Friday 12 May 2000.

Submissions should be marked for the attention of Anthony Morcombe, Strategic and Corporate Planning.

ROB SKINNER
Chief Executive Officer

Planning and Environment Act 1987
HOBSONS BAY PLANNING SCHEME
Notice of Amendment
Amendment C6

The Hobsons Bay City Council has prepared Amendment C6 to the Hobsons Bay Planning Scheme.

The Amendment affects the following land: Land situated at 295 Queen Street, Altona and more accurately described as Lot 1, Plan of Subdivision 433356T. The subject site comprises an area of 1,581 square metres and was the former Caretaker's Residence associated with the Western Purification Plant No. 2 of City West Water.

The Amendment proposes to change the Hobsons Bay Planning Scheme by: Rezoning the subject land from "Public Use Zone – Service and Utility" to "Residential 1 Zone".

A copy of the Amendment may be inspected at the following locations during office hours: Hobsons Bay City Council, 115 Civic Parade, Altona 3018; Department of Infrastructure, Upper Plaza, Nauru House, 80 Collins Street, Melbourne 3000; Altona Library, 123 Queen Street, Altona; Williamstown Library, 104 Ferguson Street, Williamstown; Newport Library, 13 Mason Street, Newport and Laverton Library, Shop 2, Central Square Shopping Centre, Laverton.

Submissions about the Amendment must be sent to: The Chief Executive Officer, Hobsons Bay City Council, P.O. Box 21, Altona 3018 by Tuesday 16 May 2000.

KEN McNAMARA
Chief Executive Officer

Planning and Environment Act 1987
WHITTLESEA PLANNING SCHEME
Notice of Amendment
Amendment C2

Notice of an Application for Planning Permit
Application 705484

The amendment and the planning permit application affect land on the north-east corner of Mahoneys Road and Edgars Road, Thomastown. The land is more accurately described as Lot 2 on Plan of Subdivision 402696S.

The amendment proposes to rezone the land from Industrial 1 Zone to Business 1 Zone.

The permit application seeks approval to develop and use the land for the purpose of a Direct Factory Outlet retail centre with a gross floor area of 17,996 square metres.

You may inspect the amendment and the application, any documents that support the amendment and application and the explanatory report about the amendment and application at the following locations: City of Whittlesea, Civic Centre, Ferres Boulevard, South Morang and Department of Infrastructure, Customer Service Centre, Upper Plaza, Nauru House, 80 Collins Street, Melbourne.

This can be done during office hours and is free of charge.

Any person who may be affected by the amendment or the granting of the permit can

make a submission to the planning authority. Submissions must be sent to: Chief Executive Officer, City of Whittlesea, Locked Bag 1, Bundoora MDC 3083.

Submissions are to be received by Monday 15 May 2000.

GRAEME BRENNAN
Chief Executive Officer

Planning and Environment Act 1987
WHITTLESEA PLANNING SCHEME
Notice of Amendment

Amendment C4

The City of Whittlesea has prepared amendment C4 to the Whittlesea Planning Scheme.

The amendment affects land north of Findon Road, within Stages 1A, 1B, 1C, 2A and 2B of the Mill Park Lakes Estate, in South Morang. Other parts of the Mill Park Lakes Estate that are presently undeveloped are also affected. These areas are included in Lot 2 on PS 344371T.

The amendment proposes to change Maps 17 and 18 of the Whittlesea Planning Scheme by rezoning some land from Residential 1 Zone to Urban Floodway Zone. A small area of land in Stage 1A of the Estate will be rezoned from Urban Floodway Zone to Residential 1 Zone.

The parcel of land alongside the main retarding basin that contains the pump station site, will be rezoned from Residential 1 Zone to Public Use Zone - Service and Utility.

The amendment will significantly reduce the extent of the Land Subject to Inundation Overlay so that it only applies to the land that may be affected by a 1 in 100 year flood under the recently altered drainage conditions.

The proposed changes in zoning and overlay controls reflect the modified drainage patterns that have resulted from the construction of channels and retarding basins associated with the drainage scheme approved by Melbourne Water.

The amendment and explanatory report can be inspected at: City of Whittlesea, Civic Centre, Ferres Boulevard, South Morang and Department of Infrastructure, Customer Service Centre, Upper Plaza, Nauru House, 80 Collins Street, Melbourne.

This can be done during office hours and is free of charge.

Any person who may be affected by the amendment can make a submission to the planning authority. Submissions must be sent to: Chief Executive Officer, City of Whittlesea, Locked Bag 1, Bundoora MDC 3083.

Submissions are to be received by Monday 15 May 2000.

GRAEME BRENNAN
Chief Executive Officer

Planning and Environment Act 1987
WHITTLESEA PLANNING SCHEME
Notice of Amendment

Amendment C11

The City of Whittlesea has prepared Amendment C11 to the Whittlesea Planning Scheme.

The amendment applies to 19-35 Findon Road, Epping comprising approximately 1.44 hectares of land fronting the south side of Findon Road generally opposite its intersection with Brush Road.

The amendment proposes to change the Whittlesea Planning Scheme by rezoning that part of the land above the designated flood level from the 'Urban Floodway Zone' to the 'Residential 1 Zone', and removing the 'Land Subject To Inundation Overlay' from it.

The amendment corrects an anomaly currently in the Planning Scheme, where the whole of the land was zoned 'Urban Floodway' when the new Planning Scheme was introduced on 8 July 1999. This occurred even though part of the land was above the designated flood level and a planning permit had previously been issued by Council to subdivide this land into residential lots. The effect of the current zoning is that although the subdivision can proceed, the construction of houses on the lots is prohibited.

The amendment will facilitate the construction of houses on the resultant lots without the need for planning approval.

The amendment can be inspected free of charge during office hours at: Department of Infrastructure, Customer Service Centre, Upper Plaza, Nauru House, 80 Collins Street, Melbourne 3000 and City of Whittlesea, Planning Services Department, Civic Centre, Ferres Boulevard, South Morang 3752.

Submissions to the amendment must be sent to: The Chief Executive Office, City of Whittlesea, Locked Bag 1, Bundoora MDC 3083 by Tuesday 16 May 2000.

GRAEME BRENNAN
Chief Executive Officer

Planning and Environment Act 1987

BAW BAW PLANNING SCHEME

Notice of Amendment

Amendment C10

The Baw Baw Shire Council has prepared Amendment C10 to the Baw Baw Planning Scheme.

The Amendment affects all land in the Baw Baw Shire.

The Amendment proposes to amend the local policy regarding house lot excisions, include a policy regarding houses in rural areas and include a local policy regarding Broiler Farms. The Amendment will also include a new schedule to the Environmental Significance Overlay 1 and the Erosion Management Overlay and rezoning of land to the north of the Warragul Township.

You may inspect the Amendment, any documents that support the amendment and the explanatory report about the amendment at the following locations: Baw Baw Shire Council, Warragul Customer Service Centre, Shop 1, 61 Smith Street, Warragul; Drouin Customer Service Centre, 33 Young Street, Drouin; Trafalgar Customer Service Centre, Princes Highway, Trafalgar; Latrobe Shire Council, Moe Office, corner Albert and Kirk Streets, Moe; the Department of Infrastructure, Planning Division, 120 Kay Street, Traralgon and Department of Infrastructure, Level 3 Plaza, Nauru House, 80 Collins Street, Melbourne.

This can be done during office hours and is free of charge.

Any person who may be affected by the amendment may make a submission to the planning authority. A submission must be made in writing and sent or delivered to: The Chief Executive Officer, Baw Baw Shire Council, P.O. Box 304, Warragul, Vic. 3820; delivered to Warragul, Drouin or Trafalgar, Customer Service Centres.

The date for the close of exhibition and receipt of submissions is 8 June 2000 at 5.00 p.m.

RICHARD PERRY
Corporate & Strategic Planner

EXEMPTION

Application No. A97 of 2000

The Victorian Civil and Administrative Tribunal has considered an application pursuant to Section 83 of the **Equal Opportunity Act 1995** by Catherine Morrow in respect of Catherine's Aromatherapy & Relaxation Massage service. The application for exemption is to enable the applicant to provide her services to women only.

Upon reading the material tendered in support of this application the Tribunal is satisfied that it is appropriate to grant an exemption from Sections 42, 100 and 195 of the Act to enable the applicant to provide her services to women only.

In granting this exemption the Tribunal noted:

- The applicant provides hourly treatments in aromatherapy and relaxation massage alone from her own premises. She regards the need to protect her personal safety and that of her child in this environment as a significant consideration.
- The applicant wants to establish a clinic specialising in women's health in a female only environment which clients find is comfortable, less embarrassing and safer given that there is a need for clients to undress when massage is performed.
- The applicant wishes to provide her services in a non-threatening environment to female clients who may have been the victims of abuse or violence.

The Tribunal grants an exemption from the operation of Sections 42, 100 and 195 of the **Equal Opportunity Act 1995**, to enable the applicant to provide her services to women only.

This exemption is to remain in force from the day on which notice of the exemption is published in the Government Gazette until 12 April 2003.

Dated this 6 April 2000.

Ms CATE McKENZIE
Deputy President

EXEMPTION

Application No. A98 of 2000

The Victorian Civil and Administrative Tribunal has considered an application pursuant to Section 83 of the **Equal Opportunity Act 1995** by Annie North Inc.-Women's Domestic Violence Service. The application for exemption is to enable the applicant to operate a women's only refuge service, provided and managed by women only.

Upon reading the material tendered in support of this application the Tribunal is satisfied that it is appropriate to grant an exemption from Sections 13, 42, 100 and 195 of the Act to enable the applicant to operate a women's only refuge service, provided and managed by women only.

In granting this exemption the Tribunal noted:

- The service aims to provide, develop and extend supported accommodation, together with relevant support services for women and their dependent children, who are leaving or attempting to leave situations of domestic violence and other forms of assault and abuse against them.
- It also provides support, information, referrals and care to women who are survivors of assault and other forms of abuse through the provision of non-clinical, community based, women-centred services.
- It aims to develop links with other community agencies/services, particularly those specialising in women's accommodation services.
- The service undertakes to provide education in the community aimed at changing society attitudes, structures and institutions which support and perpetuate domestic violence and other forms of abuse and assault against women and children by:
 - providing speakers for community meetings and workshops;
 - producing and disseminating educational material, e.g. pamphlets, posters;
 - use of media.
- The service had been granted a previous exemption which expired on 21 December 1998.

The Tribunal grants an exemption from the operation of Sections 13, 42, 100 and 195 of the **Equal Opportunity Act 1995**, to enable the applicant to operate a women's only refuge service, provided and managed by women only.

This exemption is to remain in force from the day on which notice of the exemption is published in the Government Gazette until 12 April 2003.

Dated this 6 April 2000.

Ms CATE McKENZIE
Deputy President

EXEMPTION

Application No. A124 of 2000

The Victorian Civil and Administrative Tribunal has considered an application pursuant to Section 83 of the **Equal Opportunity Act 1995** by Anglicare Victoria. The application for exemption is to enable the applicant to advertise and employ female Residential Care staff to work within the Southbridge Youth Accommodation Program within Anglicare Southbridge Youth Services.

Upon reading the material tendered in support of this application the Tribunal is satisfied that it is appropriate to grant an exemption from Sections 13, 42, 100 and 195 of the Act to advertise and employ female Residential Care staff to work within the Southbridge Youth Accommodation Program within Anglicare Southbridge Youth Services.

In granting this exemption the Tribunal noted:

- Anglicare Southbridge Youth Services is a leading service for adolescents in Melbourne's southern suburbs, providing programs for young people 12 to 18 years of age.
- The services provided include preventative case-management support for young people living with their families; intensive support for young people who are homeless, and youth accommodation programs, incorporating Adolescent Community Placement and Intensive High Risk Accommodation.
- As part of the High Risk Accommodation Initiative, the service will be establishing specific residential settings designed around the needs of young people, who are clients of the Department of Human Services who have been designated to need an intensive one-to-one accommodation based on their challenging needs. These could include: a history of multiple placements, substance abuse which impacts on day to day coping skills or psychiatric or intellectual disabilities.

- The accommodation provided will usually accommodate one to two young people and when necessary will be gender specific. When accommodating women together, it is deemed as appropriate and integral to the client's needs to have a female staff member available to these young women.
- Female residential staff would be expected to effectively engage young women and work as a part of team to provide flexible work approaches to the challenging behaviours and disability issues presenting with these young women.
- Young women will often specifically wish to discuss issues with a female staff member due to past relationships with males, especially where there has been a history of sexual abuse, and will often not participate in the program if this need is not met.
- It is essential for female clients who have had a history of sexual or physical abuse to feel safe in their residential setting knowing that there are no males present. This kind of history often leaves young women frightened, vulnerable and unable to relate appropriately with men. It may also leave a male worker vulnerable to possible allegations of abuse.

The Tribunal grants an exemption from the operation of Sections 13, 42, 100 and 195 of the **Equal Opportunity Act 1995**, to enable the applicant to advertise and employ female Residential Care staff to work within the Southbridge Youth Accommodation Program within Anglicare Southbridge Youth Services.

This exemption is to remain in force from the day on which notice of the exemption is published in the Government Gazette until 12 April 2003.

Dated this 6 April 2000.

Ms CATE McKENZIE
Deputy President

EXEMPTION

Application No. A130 of 2000

The Victorian Civil and Administrative Tribunal has considered an application pursuant to Section 83 of the **Equal Opportunity Act 1995** by Dental Health Services Victoria for exemption from Sections 13, 100 and 195 of that Act. The application for exemption is to

enable the applicant to advertise and employ for two positions as research assistants in its Migrant Dental Health project, one position to be occupied by a person with skills in written and spoken English and Italian, and the other position to be occupied by a person with skills in written and spoken English and Greek.

Upon reading the material submitted in support of the application and upon hearing submissions from Mr Palmer and Professor Wright and for the Reasons for Decision given by the Tribunal on 11 April 2000, the Tribunal is satisfied that it is appropriate to grant an exemption from Sections 13, 100 and 195 of the Act to enable the applicant to advertise and employ for two positions as research assistants in its Migrant Dental Health project, one position to be occupied by a person with skills in written and spoken English and Greek.

The Tribunal hereby grants an exemption to the applicant from the operation of Sections 13, 100 and 195 of the **Equal Opportunity Act 1995** to enable the applicant to advertise and employ for two positions as research assistants in its Migrant Dental Health project, one position to be occupied by a person with skills in written and spoken English and Italian, and the other position to be occupied by a person with skills in written and spoken English and Greek.

This exemption is to remain in force from the day on which notice of the exemption is published in the Government Gazette until 12 April 2003.

Dated 11 April 2000.

CATE McKENZIE
Deputy President

N.B. A copy of the Reasons for Decision is available from the Registrar of the Anti-Discrimination List.

Creditors, next of kin and others having claims against the estate of any of the undermentioned deceased persons are required to send particulars of their claims to State Trustees Limited, A.C.N 064 593 148, 168 Exhibition Street, Melbourne, Victoria 3000, the personal representative, on or before 21 June 2000 after which date State Trustees Limited may convey or distribute the assets having regard only to the claims of which State Trustees Limited then has notice.

BANFIELD, Agnes Ellen, late of 32 Murrumbeena Road, Murrumbeena, pensioner, who died February 16, 2000.

BOYD, Merle Dorothea, late of 86 Miller Street, Preston West, pensioner, who died February 16, 2000.

BURNEY, George Frederick, late of 27 Marriott Street, St Kilda, retired, who died October 21, 1999.

D'ARGENIO, Esterina, late of St Francis of Assisi Nursing Home, 230 Rosanna Road, Rosanna, pensioner, who died August 29, 1999.

HUNT, Margaret, late of Jedasa House Nursing Home, 218-244 Lower Plenty Road, Rosanna, pensioner, who died November 9, 1999.

LAURENCE, Ruby Isabel, formerly of 3/18 McLean Road, Bundoora, but late of Deloraine Private Nursing Home, 18 Adeline Street, Greensborough, retired office manager, who died August 22, 1999.

LEGGO, Jean Angwin, late of Hawthorn Grange, 7-9 Hunter Street, Hawthorn, pensioner, who died January 1, 1999.

MORAN, Bernard Michael, late of 5-14 Milton Street, Elwood, retired, who died July 10, 1990.

SHEEHY, Anthony Gerard, late of 48 Stuart Street, The Basin, roof plumber, who died January 29, 2000.

SMIRNOV, Nikita, late of Waybridge Nursing Home, 72 Ascot Vale Road, Flemington, retired, who died January 8, 2000.

STEVENS, Lorna Dorothy, late of St Lawrences Nursing Home, 56 High Street, Grange, South Australia, home duties, who died January 12, 2000.

Dated at Melbourne, 12 April 2000.

CATHY VANDERFEEN
Manager, Estate Management
State Trustees Limited

Country Fire Authority Act 1958

VARIATION OF FIRE DANGER PERIOD

In pursuance of the powers conferred by Section 4 of the **Country Fire Authority Act 1958**, I, Leonard Raymond Foster, Chairman of the Country Fire Authority, after consultation with the Secretary of Natural Resources and

Environment, hereby vary the declaration of the Fire Danger Periods previously published in the Government Gazette by declaring that such Fire Danger Periods shall end in respect of the undermentioned Municipal Districts of Municipalities or parts of Municipalities specified.

To terminate from 01.00 hours on 17 April 2000:

Southern Grampians Shire Council, Corangamite Shire Council, Colac/Otway Shire Council, Rural City of Ararat, Pyrenees Shire Council.

L. FOSTER
Chairman

Subordinate Legislation Act 1994

NOTICE OF DECISION

Gas Safety (Gas Appeals Board) Regulations 2000

I, John Brumby MP, Assistant Treasurer, acting concurrently with the Minister responsible for the administration of the **Gas Safety Act 1997**, under Section 12 of the **Subordinate Legislation Act 1994**, give notice as follows:

A Regulatory Impact Statement (RIS) was prepared in relation to the proposed Gas Safety (Gas Appeals Board) Regulations 2000 and advertised inviting public comment. Six submissions were received in response to the RIS. I have decided that the proposed Regulations should be made.

Dated 3 April 2000.

JOHN BRUMBY MP
Assistant Treasurer

Education Act 1958

NOTICE OF MAKING OF AN ORDER UNDER SECTION 13

An Order of the Minister for Education was made on 14 March 2000 under sections 13(4), 13(5) and 13(11) of the **Education Act 1958** dissolving the Heatherton Primary School Council and making interim arrangements for the membership of the school council and the disposal of the assets of the school council in the period prior to its dissolution.

MARY DELAHUNTY
Minister for Education

Water Act 1989

I, Peter Vernon Doughty, Director Water Sector Services, Department of Natural Resources and Environment, as delegate of the Minister for Environment and Conservation, make the following Order:

EXTENSION OF THE MACALISTER IRRIGATION DISTRICT ORDER 1999

1. This Order is called the Extension of the Macalister Irrigation District Order 1999.
2. This Order is made under section 96 (11) of the **Water Act 1989** and all other available powers.
3. The proposal for the extension of the Macalister Irrigation District of the Gippsland and Southern Rural Water Authority submitted on 2 March 2000 to the Department of Natural Resources and Environment by the Gippsland and Southern Rural Water Authority is approved.
4. The Macalister Irrigation District of the Gippsland and Southern Rural Water Authority is extended by the extent of the areas shaded in red on the accompanying plan, numbered 1067, copies of which may be inspected at the office of the Gippsland and Southern Rural Water Authority situated at 88 Johnson Street, Maffra 3860.
5. This Order takes effect from the date it is published in the Government Gazette.

Dated 22 March 2000.

PETER V. DOUGHTY
Director, Water Sector Services
Department of Natural Resources
and Environment
(as delegate of the Minister for
Environment and Conservation)

Crown Land (Reserves) Act 1978

ORDER STATING INTENTION TO GRANT A LEASE

Under Sections 17D and 17DA of the **Crown Land (Reserves) Act 1978**, Sherryl Garbutt, Minister for Environment and Conservation, being satisfied that there are special reasons which make granting a lease reasonable and appropriate in the particular circumstances and to do this will not be substantially detrimental to the use and enjoyment of any adjacent land reserved under the **Crown Land (Reserves) Act 1978**, approve the granting of a lease for a term of 21 years for the purpose of a Caravan Park by the Swan Hill Rural City Council to Kimbar Park Management Solutions over the area of Crown land described in the Schedule below and, in accordance with Section 17D(3)(a) of **Crown Land (Reserves) Act 1978**, state that:-

- (a) there are special reasons which make granting the lease reasonable and appropriate in the particular circumstances; and
- (b) to do this will not be substantially detrimental to the use and enjoyment of any adjacent land reserved under the **Crown Land (Reserves) Act 1978**.

SCHEDULE

The land shown by hatching on attached plan being the area known as the Lake Boga Public Park Reserve reserved for a Public Park in the Township of Lake Boga by Order in Council of 18 September 1923 published in the Government Gazette of 26 September 1923.

Crown Allotment: 40 Section: NO SEC
Township of LAKE BOGA (5443)
Parish of KUNAT KUNAT (2941)
LIMS ref: P005663

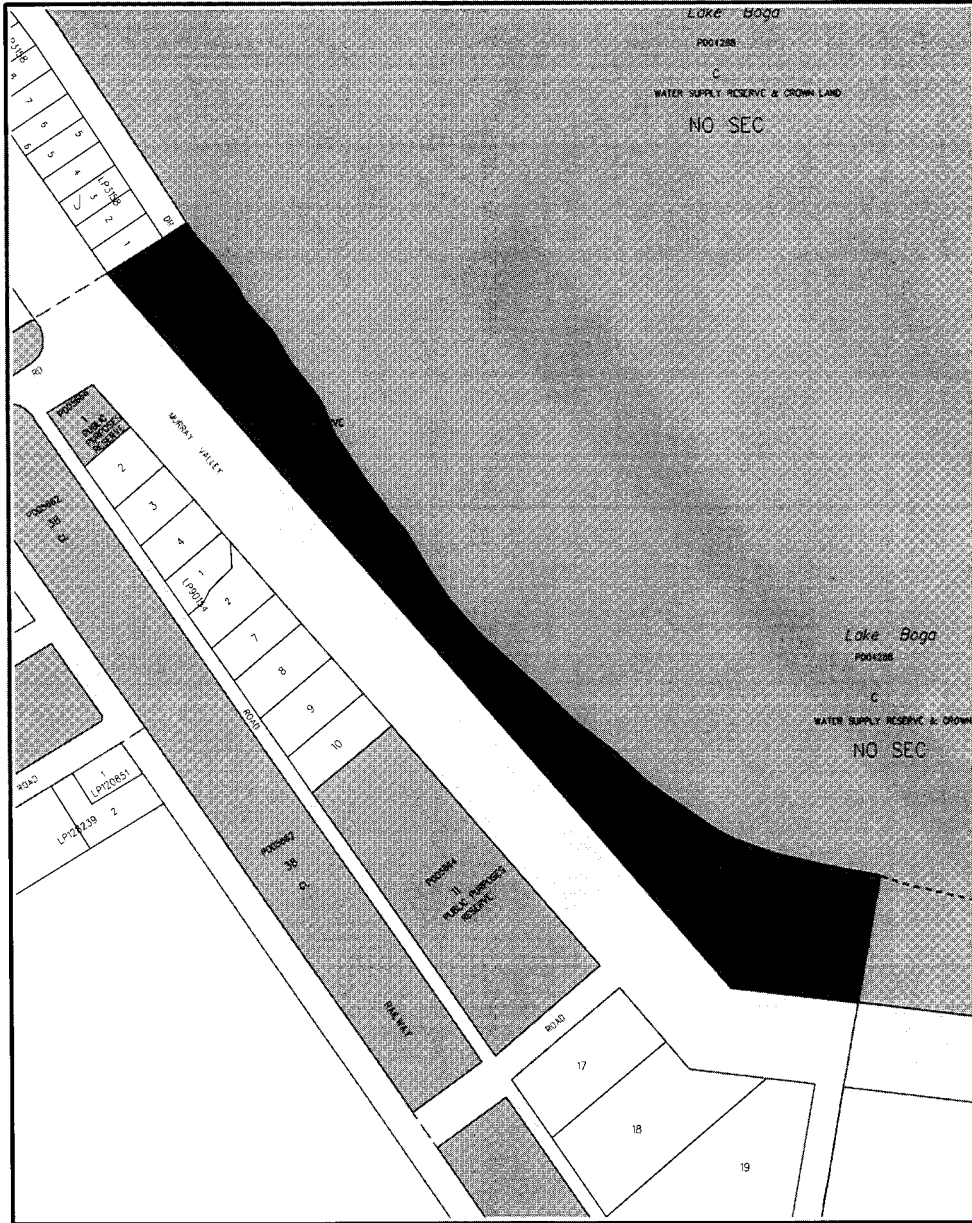

Scale 1:4000 Cadastral map base prepared by the Office of Geographic Data Coordination.

Dated 16 March 2000.

SHERRYL GARBUTT MP
Minister for Environment
and Conservation

Pipelines Act 1967VARIATION TO PERMIT TO OWN AND
USE PIPELINE 175

I, the Minister for Energy and Resources for the State of Victoria, hereby give notice in accordance with the provisions of Section 12(4) of the **Pipelines Act 1967**, that the route of Permit to Own and Use Pipeline 175 owned by Duke Eastern Gas Pipeline Pty Ltd and DEI Eastern Gas Pipeline Pty Ltd is varied by:-

DELETION of the expression –

“The route of the pipeline is as indicated on the attached endorsed plans 500-AL-001 Revision 1 to 500-AL-006 Revision 1, 500-AL-007 Revision 0, 500-AL-008 Revision 1 to 500-AL-050 Revision 1, and EGP-CS-01-1102A Revision A”; and

SUBSTITUTING in lieu the expression –

“The route of the pipeline is as indicated on the attached endorsed plans 500-AL-001 Revision 1 to 500-AL-006 Revision 1, 500-AL-007 Revision 0, 500-AL-008 Revision 1 to 500-AL-020 Revision 1, 500-AL-021 Revision 2 dated 24 March 00, 500-AL-022 Revision 1 to 500-AL-050 Revision 1 and EGP-CS-01-1102A Revision A”.

Dated 7 April 2000.

CANDY BROAD
Minister for Energy and Resources

Coastal Management Act 1995CONSENT FOR USE AND DEVELOPMENT
OF COASTAL CROWN LAND

I, Sherryl Garbutt, Minister for Environment and Conservation under section 40(1)(b) of the **Coastal Management Act 1995**, hereby consent to the following uses and developments on coastal Crown land, subject to the conditions and limitations contained herein:

- 1) Existing Uses
 - a) Any use or development of land that was lawfully commenced prior to the commencement of Part 2 of the **Coastal Management Act 1995** (26 April 1995).
 - b) Any use or development where all necessary approvals were obtained prior to the commencement of Part 2 of the **Coastal Management Act 1995** and have not yet expired.
- 2) Buildings and Structures
 - a) Repairs, maintenance, restoration and renovation of existing buildings that do not occur outside of the:
 - i) existing building footprint; or
 - ii) existing building height, and
 - iii) do not involve the excavation of any land; and
 - iv) do not alter the exterior design (including demolition) or result in the building being used for a new or additional purpose.
 - b) Repairs and maintenance of fences that does not involve:
 - i) increasing the length or size (including height) of fencing; and
 - ii) re-alignment of fencing; or
 - iii) removal and replacement of fencing.
 - c) Sub-clauses (b)(i), (b)(ii) and (b)(iii) do not apply to the installation of emergency or temporary fencing that is required for the purposes of public safety.
 - d) Repairs, maintenance and replacement of signs that does not involve:
- c) Any use of the land that is a normal permitted use of the land under the relevant instrument of management.
 - i) Instrument of management is defined for the purpose of this consent as any reservation, appointment, Act of Parliament or tenure that provides for the control and management of the land by a land manager for defined purpose.
- d) Any use of the land that the land manager has the authority to permit. Such consent does not extend to:
 - i) Any occupation of the land; or
 - ii) A use that would detrimentally affect the normal use and enjoyment of the land by other users.
- e) Consent under this section does not apply to any use of the land that involves the erection of structures or excavation of land.

- i) increasing the number or size of signs;
 - ii) moving signs or replacing a sign in a position other than its existing position.
- e) Sub -clauses (d)(i) and (d)(ii) do not apply where signage is required for emergency or public safety purposes.
- f) Repairs, maintenance and replacement of any other structure that does not include:
- i) increasing the size of the structure;
 - ii) altering the location of the structure; or
 - iii) altering the nature of the structure so the purpose of the structure is varied.
- g) For the purpose of this consent a structure is defined as any built asset fixed to the land that does not include, buildings, services, roads, fences, signs or navigational equipment.
- 3) Roads and Tracks
- a) Maintain and repair roads where the works occur within the alignment of an existing formed road.
 - b) For the purposes of sub-clause (a) a road includes roadways, road surfaces, kerbs, gutters, footpaths, boardwalks, bridges, stairways, safety barriers adjoining roads, roundabouts, car parks and median strips.
- 4) Services
- a) Repair and maintenance of existing gas, electricity, water, navigational, drainage, sewerage and telecommunication infrastructure.
 - b) Consent does not apply where the repair or maintenance works requires the clearance of vegetation or the breaking of soil.
 - c) Sub-clause (b) does not apply where emergency repairs are required.
- 5) Management of Plants and Animals
- a) Maintenance of vegetation which includes:
 - i) trimming and pruning of vegetation to maintain path roads, fire access tracks, existing buildings and structures, signs and overhead services.
 - ii) mowing of grass;
 - iii) removal of dangerous trees and tree limbs for public risk management;
 - iv) revegetation using indigenous plant species;
 - v) erosion stabilisation works;
 - vi) control and removal of pest plants.
 - vii) Maintenance of vegetation does not include:
 - clearance of vegetation;
 - increasing the area of exotic plantings; or
 - landscaping.
 - b) Control and eradication of pest animals.
- 6) Emergency Services and Works
- a) Any actions carried out that falls within the provisions of the **Emergency Management Act 1986** and is carried out by a person or body that is empowered to carry out functions under that Act.
 - b) Any emergency or temporary risk mitigation works undertaken by a land manager to ensure the safety of the land users of general public, including the demolition of dangerous structures, buildings and roads.
 - c) The removal, incineration or burying of dead animals that pose a risk to public health.
- 7) Conditions on Consent
- a) This consent does not apply to any use or development of coastal Crown land that is in contradiction of any approved coastal actions plan, management plan, works plan, pest management plan or fire management plan.
 - b) This consent is given without prejudice only constitutes consent under the **Coastal Management Act 1995**. Where any use or development that is consented to here is subject to a planning process under the provisions of the **Planning and Environment Act 1987**, any requirement for the Department's consent as landowner,

public land manager or referral authority is still required.

- c) Consent under clauses 2(b), 2(d), 2(f), 3(a) and 4(a) is limited to developments and works under the value of \$10,000.
- d) Right is reserved for this consent to be withdrawn where a particular use or development is deemed worthy of special consideration.

Dated: 14 March 2000

SHERRYL GARBUTT MP
Minister for Environment and Conservation

Crown Land (Reserves) Act 1978
ORDER GIVING APPROVAL TO
GRANT OF LEASE

Pursuant to sections 17D(1) and 17DA of the **Crown Land (Reserves) Act 1978**, I Sherryl Garbutt, Minister for Environment and Conservation, being satisfied that there are special reasons which make granting a lease reasonable and appropriate in the particular circumstances and to do this will not be substantially detrimental to the use and enjoyment of any adjacent land reserved under the **Crown Land (Reserves) Act 1978**, approve the granting of a lease by the Whittlesea Showgrounds and Recreation Reserves Committee of Management Incorporated to the Whittlesea Horse & Pony Club Inc. and Findon Adult Riders Inc., over part of the Whittlesea Public Park described in the Schedule below for the purpose of the operation of equestrian clubs and associated activities and, in accordance with Section 17D(3)(a) of **Crown Land (Reserves) Act 1978**, state that:-

- (a) there are special reasons which make granting the lease reasonable and appropriate in the particular circumstances; and
- (b) to do this will not be substantially detrimental to the use and enjoyment of any adjacent land reserved under the **Crown Land (Reserves) Act 1978**.

SCHEDULE

The land shown hatched on the following plan being part of the land permanently reserved as a Public Park by Order in Council dated 4 September 1930 and published in the Government Gazette dated 10 September 1930 — Rs 2111.

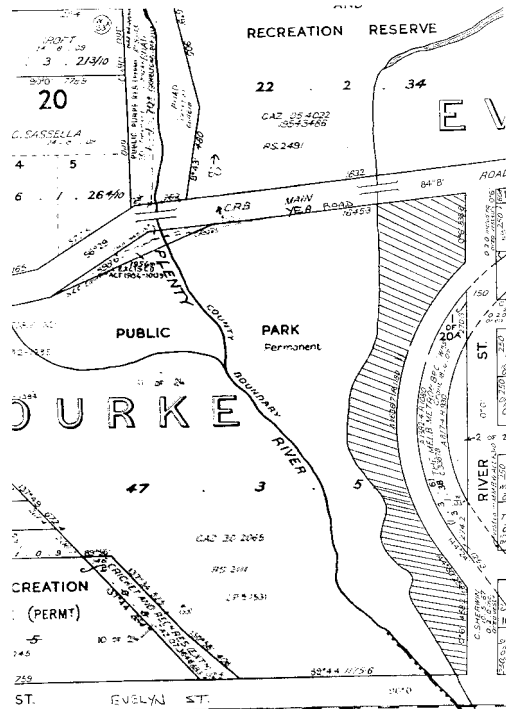

Dated 29 March 2000.

SHERRYL GARBUTT MP
Minister for Environment
and Conservation

FORM 7 S.21
Reg.16

NOTICE OF ACQUISITION

Compulsory Acquisition of Interest in Land

Roads Corporation (VicRoads) declares that by this notice it acquires the following interest in the land described as Part of Lot 9, 10 and 11 on Plan of Subdivision 11434, Parish of Warrandyte comprising 5174 square metres and being land described in Certificate of Title Volume 8086 Folio 804, shown as Parcels 1 and 2 on VicRoads Survey Plan 17977.

Interest Acquired: That of Patricia Catherine Russo as Administrator of the Estate of Gerald Joseph Hickey (deceased) and all other interests.

Published with the authority of VicRoads.

The Survey plan referred to in this notice may be viewed at the office of Property Services Department, VicRoads, 60 Denmark Street, Kew.

Dated 13 April 2000.

For and on behalf of VicRoads:
T. H. HOLDEN
Manager Property Services Department

Transport Act 1983

**TOW TRUCK DIRECTORATE OF
VICTORIA**

Tow Truck Application

Notice is hereby given that the following application will be considered by the Licensing Authority after 17 May 2000.

Notice of any objection to the granting of an application should be forwarded to reach the Director, Tow Truck Directorate of Victoria, Level 6, 14-20 Blackwood Street, North Melbourne, P.O. Box 666, North Melbourne 3051 not later than 11 May 2000.

It will not be necessary for interested parties to appear on the date specified, unless advised in writing.

Astondale Pty Ltd. Application for variation of conditions of tow truck licence number 014HTT which authorise the licensed vehicle to be managed, controlled and operated from a depot situated at 167-169 City Road, South Melbourne to change the depot address to 33-35 Franklyn Street, Huntingdale.

Dated 13 April 2000.

TERRY O'KEEFE
Director

**Planning and Environment Act 1987
Planning and Environment
(Planning Schemes) Act 1996**

FRANKSTON PLANNING SCHEME

Notice of approval of planning scheme

The Minister for Planning has approved the new Frankston Planning Scheme.

The planning scheme comes into operation on the date this notice is published in the Government Gazette.

The planning scheme affects all of the area of the municipal district of the City of Frankston and the area of Port Phillip Bay between the municipal boundary of the City of Frankston and an imaginary parallel line 600 metres from the municipal boundary.

The new Frankston Planning Scheme, as required by the **Planning and Environment (Planning Schemes) Act 1996**, includes selected State standard provisions from the Victoria Planning Provisions, including the state policy framework, various zones and overlays, particular provisions relating to use and development, administrative provisions and definitions. The new planning scheme also includes a municipal strategic statement, local policies and schedules to some of the zones, overlays and other provisions. The new scheme also incorporates a number of documents specified in the planning scheme, and contains new maps applying the standardised zones and overlays to land within the area covered by the scheme.

Any planning scheme or any part of a planning scheme in force immediately before the commencement of the new Frankston Planning Scheme is revoked to the extent that it applies to the area covered by the new Frankston Planning Scheme. Any amendment to a planning scheme or any part of a planning scheme which is revoked lapses.

A copy of the new planning scheme can be inspected, free of charge, during office hours, at: Department of Infrastructure, Customer Service Centre, Upper Plaza, Nauru House, 80 Collins Street, Melbourne 3000; Department of Infrastructure, South East Metropolitan Region, 12 Lakeside Drive, East Burwood 3151 and Frankston City Council, Davey Street, Frankston.

PAUL JEROME
Executive Director
Planning, Heritage and
Building Division
Department of Infrastructure

**Planning and Environment Act 1987
STONNINGTON PLANNING SCHEME**
**Notice of Approval of Amendment
Amendment L67**

The Minister for Planning has approved Amendment L67 to the Stonnington Planning Scheme.

The Amendment comes into operation on the date this notice is published in the Government Gazette.

The Amendment includes the Rialto Area, East Malvern in a Heritage Overlay Area in the Stonnington Planning Scheme.

A copy of the Amendment can be inspected, free of charge, during office hours, at the Department of Infrastructure, Customer Service Centre, Upper Plaza, Nauru House, 80 Collins Street, Melbourne and at the offices of the Stonnington City Council, corner Greville and Chapel Streets, Prahran.

PAUL JEROME
Executive Director
Planning, Heritage and
Building Division
Department of Infrastructure

Planning and Environment Act 1987
QUEENSCLIFFE PLANNING SCHEME
Notice of Lapsing of Amendment
Amendment C1

The Borough of Queenscliffe has resolved to abandon Amendment C1 to the Queenscliffe Planning Scheme.

The Amendment proposed to include the Queenscliffe Planning Scheme a new local policy titled '22.04 Coastal Areas and Foreshore Management'. The proposed policy identified the nature and scope of the responsible authority's role in the management of coastal areas through the planning scheme and provided principles for the use and development of land in coastal areas.

The Amendment lapsed on 30 March 2000.

PAUL JEROME
Executive Director
Planning, Heritage and
Building Division
Department of Infrastructure

Planning and Environment Act 1987
QUEENSCLIFFE PLANNING SCHEME
Notice of Lapsing of Amendment
Amendment C2

The Borough of Queenscliffe has resolved to abandon Amendment C2 to the Queenscliffe Planning Scheme.

The Amendment proposed to change the Local Planning Policy Framework, Zones, Overlays and Maps to implement the draft Queenscliffe Coastal Action Plan into the Queenscliffe Planning Scheme.

The Amendment lapsed on 30 March 2000.

PAUL JEROME
Executive Director
Planning, Heritage and
Building Division
Department of Infrastructure

Planning and Environment Act 1987
YARRA RANGES PLANNING SCHEME
Notice of Lapsing of Amendment
Amendment L121

The Yarra Ranges Shire Council has resolved to abandon Amendment L121 to the Yarra Ranges Planning Scheme.

The Amendment proposed to allow subdivision of lot 11 LP15574, 72 Ridge Road, Kallista into two lots.

The Amendment lapsed on 7 March 2000.

PAUL JEROME
Executive Director
Planning, Heritage and
Building Division
Department of Infrastructure

ORDERS IN COUNCIL

Control of Weapons Act 1990

The Lieutenant-Governor as the Governor's deputy, with the advice of the Executive Council, under Section 5(2) of the **Control of Weapons Act 1990**, grants the following exemptions:

- Mr Christopher James COOPER of 14 Eldorado Crescent, Meadow Heights 3048 to enable him to import, purchase and possess daggers as a bona-fide collector.
- Mr Daniel BRIGANTE of 3 Ardoch Street, Gladstone Park 3043 to enable him to import and possess two blowguns as ornaments.
- Ms Sharon Patricia JACKMAN of 49 Oxford Street, Newport 3015 to enable her to import and possess a blowgun as an ornament.
- Ms Jasmine FRICKER of 30 Beatrice Avenue, Essendon 3040 to enable her to import and possess a blowgun as an ornament.
- Ms Susan Lee KILLEEN of 26-30 Carey Drive, Glengarry 3854 to enable her to import and possess two blowguns as ornaments.
- Mr John Maurice KNIGHT of 1 Milton Street, Canterbury 3126 to enable him to import and possess a blowgun as an ornament.
- Mr Maurice LIBERMAN of 83 Caroline Street, South Yarra 3141 to enable him to import and possess a blowgun as an ornament.
- Mr Jonathan LOFTES of 5C/18 Albert Road, South Melbourne 3205 to enable him to import and possess daggers as a bona-fide collector.
- Mrs Clare Elizabeth McDONALD of 17 Isaacs Close, Sunbury 3249 to enable her to import, purchase and possess daggers as a bona-fide collector.
- Mr Paul Stuart PHILLIPS of 52 Kingston Drive, Dingley 3172 to enable him to import and possess a blowgun as an ornament.
- Mr Robert James MEALYEA of 3 Hampden Road, Armadale 3143 to enable him to import, purchase and possess flick knives as a bona-fide collector.

- Mr Nick SALADINO of 84 Moonee Boulevard, Glenroy 3046 to enable him to import and possess a blowgun as an ornament.

- Mr Garry Michael TAYLOR of 25 Southey Road, Boronia 3155 to enable him to import and possess a blowgun as an ornament.

Persons specified above are subject to storage and safety conditions as specified by the Chief Commissioner.

Dated 4 April 2000.

Responsible Minister:
ANDRÉ HAERMAYER
Minister for Police and
Emergency Services

STACEY ROBERTSON
Acting Clerk of the Executive Council

Control of Weapons Act 1990

The Lieutenant-Governor as the Governor's deputy, with the advice of the Executive Council, under Section 5(2) of the **Control of Weapons Act 1990**, grants the following exemptions:

- Mr Kevin John BROWN of 2 Nambour Road, Keysborough 3173 to enable him to import and possess a blowgun as an ornament.
- Mr Hugh Francis DOHERTY of 2 Sheridan Grove, Caulfield South 3126 to enable him to import, purchase, possess, carry and use daggers and butterfly knives for the purposes of martial arts training and demonstration.
- Mr Neil HARROP of 39 North Street, Kerang 3579 to enable him to import and possess a blowgun as an ornament.
- Mr Robert Anthony KELLY of 5 Burton Street, Bittern 3918 to enable him to import, purchase and possess daggers as a bona-fide collector.
- Ms Katerina LAFASANIDIS of 32 Cash Avenue, Mount Waverley 3149 to enable her to import and possess a blowgun as an ornament.
- Mr Colin Gordon LEACH of 25 Riverview Terrace, Warrnambool 3280 to enable him to import and possess a dagger as a family heirloom.

- Mr Ralph Jack MACKENZIE of 18 Eugenia Street, Rye 3941 to enable him to import and possess two blowguns as ornaments.
- Mr Daryl Bruce Monot MILLS of Unit 1/28 Lake Road, Blackburn 3130 to enable him to import and possess a blowgun an an ornament.
- Mr Timothy Andrew ROBERTSON of 7 Middlesex Road, Surrey Hills 3127 to enable him to import and possess a blowgun as an ornament.
- Mr Angelo TORRESAN of 8 Hassett Court, Wantirna South 3153 to enable him to import and possess two blowguns as ornaments.
- Mr Philip Kevin WALTER of 3 Walker Street, North Geelong 3215 to enable him to import, purchase and possess daggers, butterfly knives and flick knives as a bona-fide collector.
- Ms Jillian WOINARSKI of 14 Wellesley Road, Hawthorn 3122 to enable her to import and possess a blowgun as an ornament.

Persons specified above are subject to storage and safety conditions as specified by the Chief Commissioner.

Dated 4 April 2000.

Responsible Minister:
 ANDRÉ HAERMEYER
 Minister for Police and
 Emergency Services

STACEY ROBERTSON
 Acting Clerk of the Executive Council

Forests Act 1958

EXCHANGE OF RESERVED FOREST FOR CROWN LAND

The Governor in Council under Section 49(1) of the **Forests Act 1958** authorises, in exchange for the Crown land described in the Dedication Schedule hereunder, the excision of the lands described in the Excision Schedule hereunder from reserved forest.

DEDICATION SCHEDULE

An area of 6 hectares, more or less, of Crown land being Allotment 16F of Section E in the Parish of Undera as indicated by hatching on plan hereunder. (U62(7)) — (P162684).

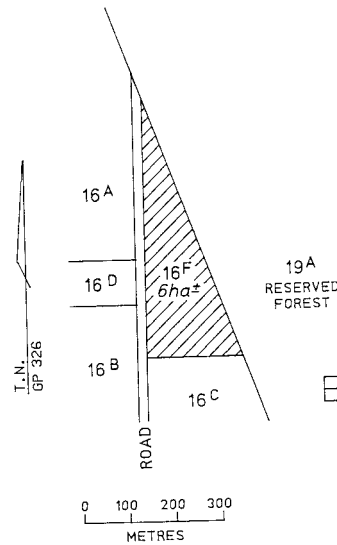

An area of 7.5 hectares, more or less, of Crown land being Allotment 27D of Section H in the Parish of Glenmona as indicated by hatching on plan hereunder. (G155(3) — (06L6-10350).

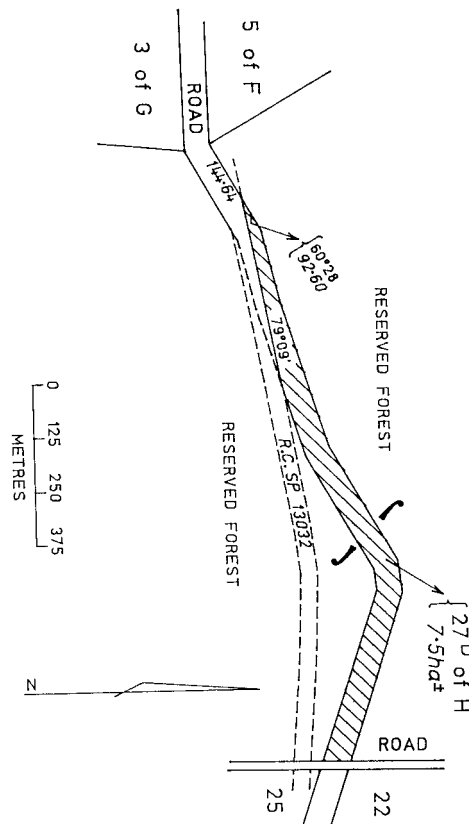

EXCISION SCHEDULE

An area of 4.5 hectares, more or less, of reserved forest being Allotments 10C and 10D in the Parish of Mullindolingong as shown on Certified Plan 109102 lodged in the Central Plan Office. (M477(5) — (P205582).

An area of 4.83 hectares, more or less, of reserved forest being Allotment 365U in the Parish of Sandhurst as shown on Certified Plan 119989 lodged in the Central Plan Office. — (06L6-10373).

An area of 8096 square metres, more or less, of reserved forest being Allotment 52J1 in the Parish of Binginwarri as shown on Certified Plan 119932 lodged in the Central Plan Office. — (P280765).

An area of 3.5 hectares, more or less, of reserved forest being the land in the Parish of Borhoneyghurk as shown by hatching on plan hereunder. (L1-4742).

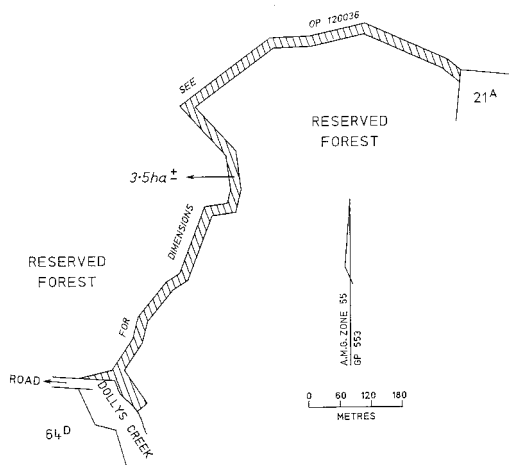

Such excisions and dedication to come into effect on the fourteenth day after publication of this Order in the Victoria Government Gazette.

Dated 11 April 2000.

Responsible Minister:
SHERRYL GARBUTT
Minister for Environment
and Conservation

STACEY ROBERTSON
Acting Clerk of the Executive Council

Land Act 1958**APPROVAL TO THE SALE OF CROWN LAND BY PRIVATE TREATY**

Order in Council

The Governor in Council, pursuant to sections 99A(1)(a) & 99A(2) of the **Land Act 1958**, approves the sale by private treaty of Crown Allotment 22, Section 3, Parish of Cardigan, County of Grenville located at Wallis Street, Ballarat.

Dated: 11 April 2000.

Responsible Minister:
JOHN BRUMBY MP
Minister for Finance

STACEY ROBERTSON
Acting Clerk of the Executive Council

Crown Land (Reserves) Act 1978**CROWN LANDS TEMPORARILY RESERVED**

The Governor in Council under section 4(1) of the **Crown Land (Reserves) Act 1978** temporarily reserves the following Crown lands for Public Purposes (Recreation and Conservation) :-

**MUNICIPAL DISTRICT OF THE
SOUTHERN GRAMPIANS SHIRE
COUNCIL**

COLERAINE — Public Purposes (Recreation and Conservation), 50 hectares, more or less, being Crown Allotment 2A, Section 13, Township of Coleraine and Crown Allotments 16A and 9, Section 2, Crown Allotment 3A, Section 15, Crown Allotment 1A, Section 19 and Crown Allotment 3C, Section 23, Parish of Coleraine as shown outlined red on Plan No. LEGL./99-183 lodged in the Central Plan Office;

REDRUTH and WANNON — Public Purposes (Recreation and Conservation), 39 hectares, more or less, being Crown Allotments 10A, 11A, and 12, Section 25 and Crown Allotments 10A and 10B, Section 14, Parish of Redruth and Crown Allotments 27A, 22C, 19A, 5A, 11C and 13C, Township of Wannon as shown outlined red on Plan No. LEGL./99-184 lodged in the Central Plan Office;

BOCHARA — Public Purposes (Recreation and Conservation), 48 hectares, more or less,

being Crown Allotments 1G and 4A, Section 1B, Crown Allotment 3A, Section 12, Crown Allotment 10B, No Section, Crown Allotment 5A, Section 13, Crown Allotment 8A, Section 14, Crown Allotment 5A, Section 17 and Crown Allotment 11A, Section 1, Parish of Bochara as shown outlined red on Plan No. LEGL./99-185 lodged in the Central Plan Office; and

HAMILTON, HAMILTON NORTH and HAMILTON SOUTH — Public Purposes (Recreation and Conservation), 20 hectares, more or less, being Crown Allotment 61C, Township of Hamilton, Crown Allotments 24A, 27A and 33A, Section 1A and Crown Allotment 14A, Parish of Hamilton North and Crown Allotments 18A, 18B, 24A and 45A, Section B and Crown Allotments 26A, 29A and 37A, Parish of Hamilton South as shown outlined red on Plan No. LEGL./99-186 lodged in the Central Plan Office. — (Rs 43106).

This Order is effective from the date on which it is published in the Government Gazette.

Dated: 11 April 2000.

Responsible Minister
SHERRYL GARBUTT
Minister for Environment and Conservation
STACEY ROBERTSON
Acting Clerk of the Executive Council

Crown Land (Reserves) Act 1978

NOTICE OF INTENTION TO REVOKE TEMPORARY RESERVATIONS

The Governor in Council under section 10 of the **Crown Land (Reserves) Act 1978** gives notice of intention to revoke the following temporary reservations:

CARLYLE — The temporary reservation by Order in Council of 12 September, 1898 of an area of 1.126 hectares of land in Section 43, Parish of Carlyle as a site for Watering purposes, revoked as to part by Order in Council of 10 January, 1939 so far as the balance remaining containing 6526 square metres. — (Rs 11/8880).

DIMBOOLA — The temporary reservation by Order in Council of 7 February, 1881 of an area of 29.097 hectares of land in Section 9, Township of Dimboola, Parish of Dimboola as a site for Public Gardens and other purposes of Public Recreation, so far only as the portion containing 7528 square metres as indicated by hatching on plan hereunder. (D150[9]) — (Rs 2260).

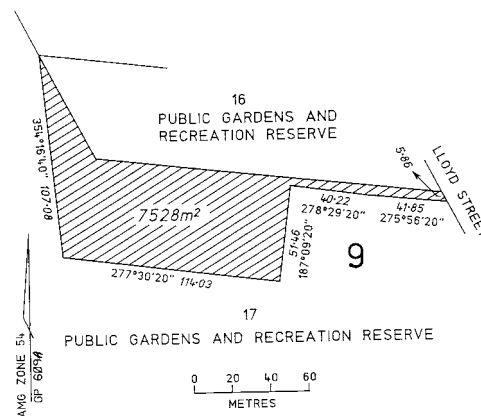

DIMBOOLA — The temporary reservation by Order in Council of 8 December, 1959 of an area of 9106 square metres, more or less, of land in Section 9, Township of Dimboola, Parish of Dimboola as a site for Public Gardens and other purposes of Public Recreation in addition to and adjoining the site temporarily reserved therefor by Order in Council of 7 February, 1881. — (Rs 2260).

LANCEFIELD — The excepting from occupation for residence or business under any miner's right or business license by Order in Council of 23 March, 1896 of an area of 4.047 hectares of land in the Township of Lancefield. — (P140252).

SWANWATER — The temporary reservation by Order in Council of 16 October, 1876 of an area of 36.402 hectares, more or less, of land in Section E, Parish of Swanwater as a site for Public purposes, revoked as to part by Orders in Council of 8 September, 1879 and 10 June, 1889 so far as the balance remaining containing 4.78 hectares, more or less. (06/P12491).

This Order is effective from the date on which it is published in the Government Gazette.

Dated 11 April 2000.

Responsible Minister:
SHERRYL GARBUTT
Minister for Environment and Conservation
STACEY ROBERTSON
Acting Clerk of the Executive Council

Crown Land (Reserves) Act 1978NOTICE OF INTENTION TO REVOKE
TEMPORARY RESERVATION

The Governor in Council under section 10 of the **Crown Land (Reserves) Act 1978** gives notice of intention to revoke the following temporary reservation:

COLIBAN — The temporary reservation by Order in Council of 21 February, 1870 of an area of 5.246 hectares of land in the Parish of Coliban as a site for Watering purposes, revoked as to part by Orders in Council of 10 November, 1874 and 21 January, 1937 so far as the balance remaining containing 1.214 hectares. — (Rs 4365).

This Order is effective from the date on which it is published in the Government Gazette.

Dated 11 April 2000.

Responsible Minister:
SHERRYL GARBUTT
Minister for Environment and Conservation
STACEY ROBERTSON
Acting Clerk of the Executive Council

Crown Land (Reserves) Act 1978REVOCATION OF TEMPORARY
RESERVATIONS

The Governor in Council under section 10 of the **Crown Land (Reserves) Act 1978** revokes the following temporary reservations:

BALLARAT — The temporary reservation by Order in Council of 7 June, 1988 of an area of 18.66 hectares of land being Crown Allotments 32 and 33, Section 1, Parish of Ballarat as a site for Public Recreation so far only as the portion containing 1145 square metres shown as Crown Allotment 26F, Section 1, Parish of Ballarat on Original Plan No. 119938 lodged in the Central Plan Office. — (Rs 11386).

GLENTHOMPSON — The temporary reservation by Order in Council of 24 February, 1970 of an area of 4553 square metres of land in Section 1, Township of Glenthompson, Parish of Yuppeckiar as a site for Public Purposes (Municipal purposes). — (Rs 9236).

HADDON — The temporary reservation by Order in Council of 11 December, 1917 of an area of 3.278 hectares of land in Section 5, Township of Haddon, Parish of Haddon as a site for Supply of Gravel. — (Rs 12703).

LOYOLA — The temporary reservation by Order in Council of 20 January, 1868 of an area of 2.709 hectares of land east of Crown Allotment 17D, Parish of Loyola as a site for Road purposes. — (P183342).

RAVENSWOOD — The temporary reservation by Order in Council of 20 November, 1883 of an area of 4528 square metres of land adjoining Crown Allotment 4A, Section 29, Parish of Ravenswood as a site for affording access to Water. — (Rs 2813).

RAVENSWOOD — The temporary reservation by Order in Council of 20 November, 1883 of an area of 1.733 hectares of land adjoining Crown Allotment 4A, Section 29, Parish of Ravenswood as a site for affording access to Water. — (Rs 2813).

SMYTHESDALE — The temporary reservation by Order in Council of 11 December, 1917 of an area of 1.619 hectares of land in Section 27, Parish of Smythesdale as a site for Supply of Gravel. — (Rs 12721).

YARROWEE — The temporary reservation by Order in Council of 6 September, 1886 of an area of 5.532 hectares of land in the Parish of Yarrowee (formerly being part of Crown Allotment 28) as a site for Supply of Material for Road making purposes, revoked as to part by Order in Council of 23 September, 1941 so far as the balance remaining containing 2.972 hectares. — (Rs 13660).

This Order is effective from the date on which it is published in the Government Gazette.

Dated 11 April 2000.

Responsible Minister:
SHERRYL GARBUTT
Minister for Environment and Conservation
STACEY ROBERTSON
Acting Clerk of the Executive Council

Crown Land (Reserves) Act 1978REVOCATION OF TEMPORARY
RESERVATIONS

The Governor in Council under section 10 of the **Crown Land (Reserves) Act 1978** revokes the following temporary reservations:

BALLARAT EAST — The temporary reservation by Order in Council of 7 February, 1944 of an area of 202 square metres, more or less, of land in Section K, Township of Ballarat

East, Parish of Ballarat (formerly City of Ballarat at Ballarat East) as a site for Plantation purposes, so far only as the portion containing 111 square metres as indicated by hatching on plan published in the Government Gazette on 9 March, 2000 — page 402. — (Rs 5481).

BALLARAT EAST — The temporary reservation by Order in Council of 12 January, 1886 of an area of 3288 square metres of land in Section K, Township of Ballarat East, Parish of Ballarat (formerly Town of Ballarat East) as a site for Drainage purposes, revoked as to part by Order in Council of 15 August, 1978 so far only as the portion containing 466 square metres as indicated by hatching on plan published in the Government Gazette on 9 March, 2000 — page 402. — (Rs 7038).

BENDIGO — The temporary reservation by Order in Council of 12 January, 1915 of an area of 1.631 hectares of land in Section O, At Bendigo, Parish of Sandhurst (formerly City of Bendigo) as a site for a State School, revoked as to part by Order in Council of 11 August, 1924 so far as the balance remaining containing 1.439 hectares. — (Rs 473).

BENDIGO — The temporary reservation by Order in Council of 11 August, 1924 of an area of 2264 square metres of land in Section O, At Bendigo, Parish of Sandhurst (formerly City of Bendigo) as a site for a State School, in addition to and adjoining the site temporarily reserved therefor by Order in Council of 12 January, 1915. — (Rs 473).

BENDIGO — The temporary reservation by Order in Council of 1 June, 1982 of an area of 3.045 hectares of land being Crown Allotment 144, Section O, At Bendigo, Parish of Sandhurst as a site for a State School. — (Rs 12099).

DEREEL — The temporary reservation by Order in Council of 21 September, 1927 of an area of 8.02 hectares of land in the Parish of Dereel as a site for the Supply of Gravel. — (Rs 3546).

DEREEL — The temporary reservation by Order in Council of 17 April, 1934 of an area of 5.767 hectares of land in the Parish of Dereel as a site for the Supply of Gravel. — (Rs 4378).

KANGAROO FLAT — The temporary reservation by Order in Council of 31 January, 1871 of an area of 2909 square metres of land being Crown Allotment 10, Section 19, Township of Kangaroo Flat, Parish of Sandhurst (formerly at Kangaroo Flat) as a site for Common School purposes. — (06/17039).

SMYTHESDALE — The temporary

reservation by Order in Council of 14 August, 1979 of an area of 18.71 hectares of land being Crown Allotment 2, Section 90, Parish of Smythesdale as a site for the supply of gravel for the construction of public roads or other public works. — (Rs 10897).

This Order is effective from the date on which it is published in the Government Gazette.

Dated 11 April 2000.

Responsible Minister:
SHERRYL GARBUTT
 Minister for Environment and Conservation
STACEY ROBERTSON
 Acting Clerk of the Executive Council

Crown Land (Reserves) Act 1978

TEMPORARY RESERVATION OF CROWN LANDS

The Governor in Council under section 4(1) of the **Crown Land (Reserves) Act 1978** temporarily reserves the following Crown lands which in his opinion are required for the purposes mentioned :-

**MUNICIPAL DISTRICT OF THE
 LODDON SHIRE COUNCIL**

BORUNG — Conservation of an area of natural interest, 4.292 hectares being Crown Allotment 49D, Section 5, Parish of Borung as indicated by hatching on plan hereunder. (B89[F1]) — (2009141).

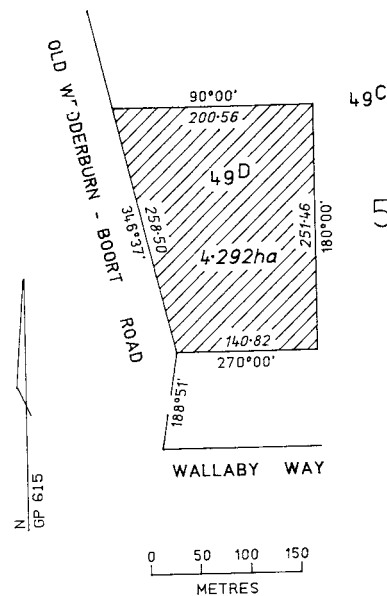

MUNICIPAL DISTRICT OF THE
MOUNT ALEXANDER SHIRE COUNCIL
CASTLEMAINE — State School purposes, 2.029 hectares being Crown Allotment 20A, Section D13, Parish of Castlemaine as shown on Certified Plan No. 114899 lodged in the Central Plan Office. — (Rs 6015).

MUNICIPAL DISTRICT OF THE
GOLDEN PLAINS SHIRE COUNCIL
DEREEL — Conservation of an area of natural interest, 48.05 hectares being Crown Allotment A11B, Parish of Dereel as indicated by hatching on plan hereunder. (D172[7]) — (L3-0212).

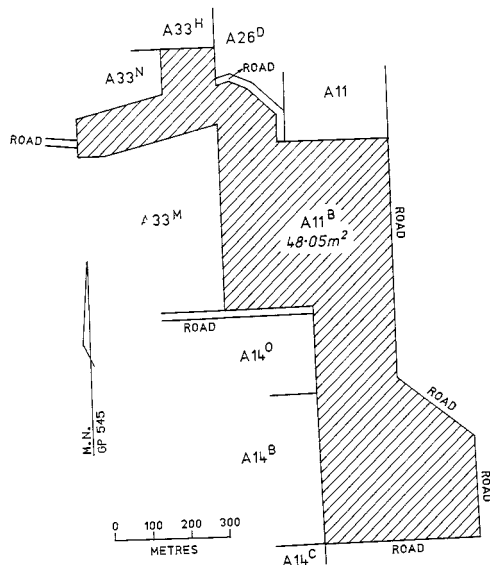

MUNICIPAL DISTRICT OF THE
GLENELG SHIRE COUNCIL

DRIK DRIK — Public Recreation and Public Hall, 4047 square metres, being Crown Allotment 9D, Section 7, Parish of Drik Drik and shown as Lot 1 on Plan of Subdivision No. 222481H lodged in the Office of Titles. — (Rs 6784).

MUNICIPAL DISTRICT OF THE
MURRINDINDI SHIRE COUNCIL

DROPMORE — Conservation of an area of natural interest, 3.635 hectares being Crown Allotment 8B, Section A, Parish of Dropmore as indicated by hatching on plan hereunder. (2546-1) — (Rs 17052).

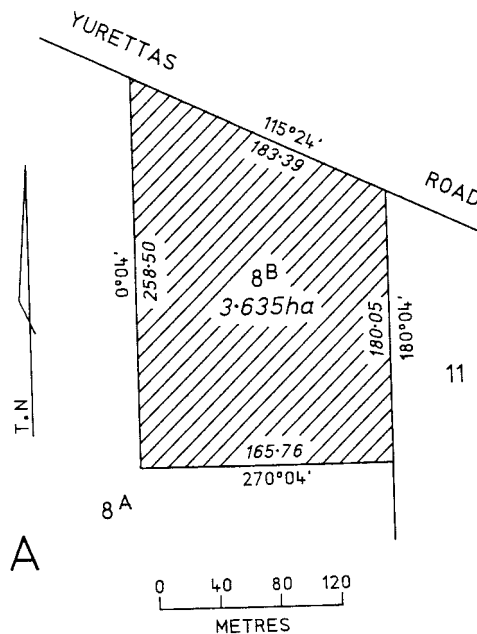

MUNICIPAL DISTRICT OF THE
BRIMBANK CITY COUNCIL

KEILOR — Cemetery purposes, 790 square metres, more or less, being Crown Allotment 44E, Township of Keilor, Parish of Dousta Galla as indicated by hatching on plan hereunder. (K24[2]) — (Rs 37060).

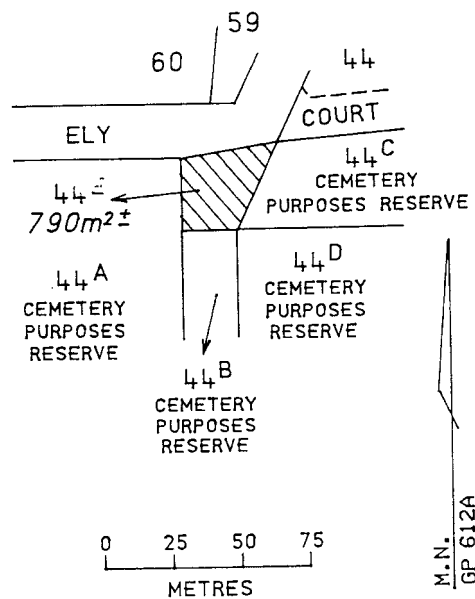

MUNICIPAL DISTRICT OF THE
GOLDEN PLAINS SHIRE COUNCIL

SMYTHESDALE — Conservation of an area of natural and historic interest, 36 hectares, more or less, being Crown Allotments 4 and 5, Section 90, Parish of Smythesdale as indicated by hatching on plan hereunder. (S297[8]) — (Rs 10897).

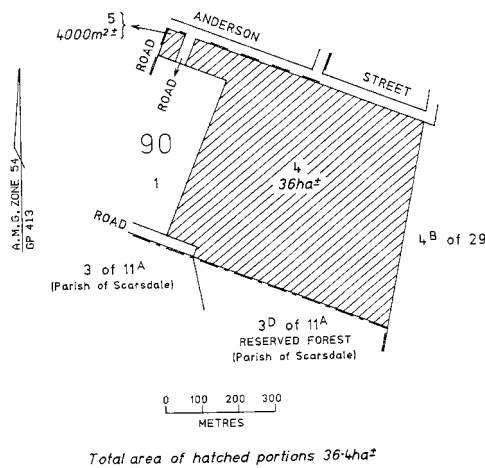

This Order is effective from the date on which it is published in the Government Gazette.

Dated 11 April 2000.

Responsible Minister:
SHERRYL GARBUTT
Minister for Environment and Conservation
STACEY ROBERTSON
Acting Clerk of the Executive Council

Land Act 1958

CLOSURE OF UNUSED ROADS

The Governor in Council under section 349 of the **Land Act 1958** and with the concurrence in writing of the municipalities in which the roads are situated closes the following unused roads:

MUNICIPAL DISTRICT OF THE
CENTRAL GOLDFIELDS SHIRE COUNCIL
AMHERST — The road in the Parish of Amherst as indicated by hatching on plan hereunder. (A28[17]) — (06/P107513).

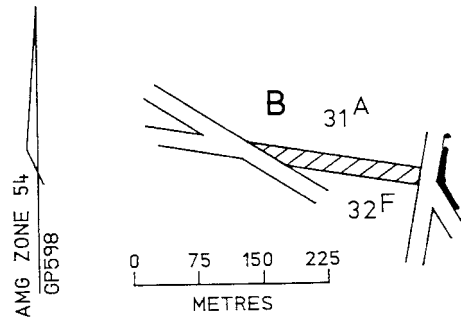

BUNG BONG — The road in the Township of Bung Bong, Parish of Bung Bong as indicated by hatching on plan hereunder. (B539[6]) — (06/P101897).

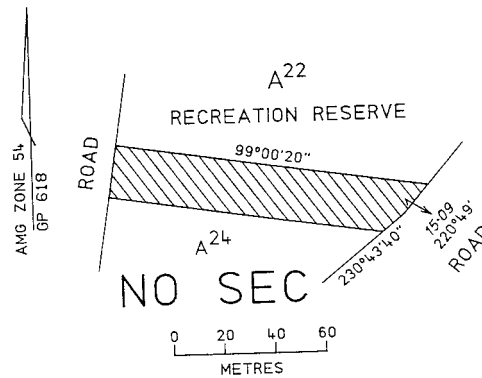

MUNICIPAL DISTRICT OF THE
BRIMBANK CITY COUNCIL
KEILOR — The road in the Township of Keilor, Parish of Dousta Galla as indicated by hatching on plan hereunder. (K24[2]) — (Rs 37060).

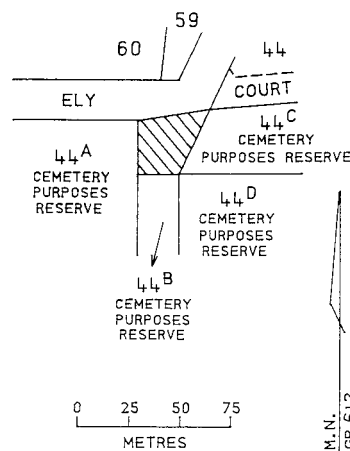

This Order is effective from the date on which it is published in the Government Gazette.

Dated 11 April 2000.

Responsible Minister:
SHERRYL GARBUTT
Minister for Environment and Conservation
STACEY ROBERTSON
Acting Clerk of the Executive Council

Land Act 1958

CLOSURE OF UNUSED ROADS

The Governor in Council under section 349 of the **Land Act 1958** and with the concurrence in writing of the municipalities in which the roads are situated and the owners of land adjoining those roads closes the following unused roads:

MUNICIPAL DISTRICT OF THE
EAST GIPPSLAND SHIRE COUNCIL
CASSILIS — The road in the Township of Cassilis, Parish of Jimkee as indicated by hatching on plan hereunder. (5161) — (P320475).

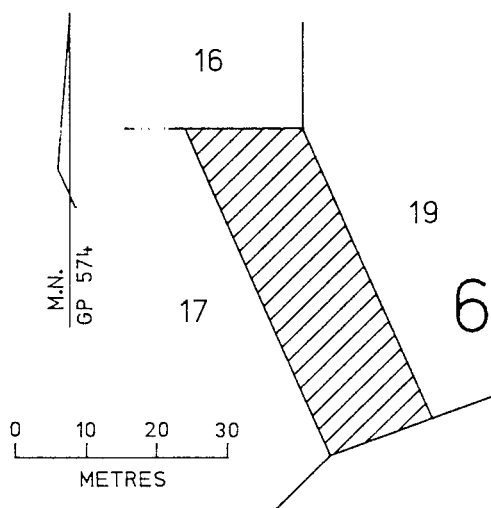

MUNICIPAL DISTRICT OF THE
CENTRAL GOLDFIELDS SHIRE COUNCIL
MARYBOROUGH — The road in the Township of Maryborough, Parish of Maryborough shown as Crown Allotments 6B and 6C, Section 69 on Original Plan No. 120041 lodged in the Central Plan Office. — (06/P107076).

This Order is effective from the date on which it is published in the Government Gazette.

Dated 11 April 2000.

Responsible Minister:
SHERRYL GARBUTT
Minister for Environment and Conservation
STACEY ROBERTSON
Acting Clerk of the Executive Council

VICTORIA

State Aid to Religion Abolition Act 1871

ACT NO. 391/1871 — SECOND SCHEDULE

A statement of trusts having been submitted by the head or authorised representative of the Uniting Church in Australia under the provisions of the "Act to provide for the abolition of State Aid to Religion" for allowance by the Governor in Council, the same was allowed by him on the Eleventh day of April, 2000 and the following is the form in which such statement of trusts has been allowed.

STATEMENT OF TRUSTS

DESCRIPTION OF LAND:-

Site for Presbyterian Place of Public Worship permanently reserved by Order in Council of 29 December, 1869 being 2015 square metres, Township of Talbot, Parish of Amherst, County of Talbot being Crown Allotment 14A, Section E.

Commencing on the south-eastern angle of allotment 12A, Section E; bounded thence by that Allotment bearing $0^{\circ} 00' 50.09$ metres; thence by allotment 12B bearing $90^{\circ} 00' 40.23$ metres; thence by Heales Street bearing $180^{\circ} 00' 50.09$ metres, and thence by the Burke Street bearing $270^{\circ} 00' 40.23$ metres to the point of commencement.

NAME OF TRUSTEES:

The Uniting Church in Australia Property Trust (Victoria).

POWERS OF DISPOSITION:

Such powers of disposition including powers of sale, lease or mortgage as are given to the Trustees by the Uniting Church in Australia act No. 9021 of 1977 as amended.

PURPOSES TOWARDS WHICH PROCEEDS OF DISPOSITION ARE TO BE APPLIED:-

To such Uniting Church in Australia purposes as shall be approved by the Synod of Victoria of the Uniting Church in Australia.

This Order is effective from the date on which it is published in the Government Gazette.
Dated 11 April 2000.

Responsible Minister:
SHERRYL GARBUTT
Minister for Environment and Conservation

STACEY ROBERTSON
Acting Clerk of the Executive Council

Crown Land (Reserves) Act 1978
INCORPORATION OF COMMITTEES OF MANAGEMENT AND APPOINTMENT OF
CHAIRPERSONS

The Governor in Council under section 14A(1) of the **Crown Land (Reserves) Act 1978**, being satisfied that it is in the public interest to declare to be corporations the Committees of Management appointed under section 14(2) of the Act of the lands described in Column 1 of the schedule hereunder :-

- (a) declares that the Committees of Management shall be corporations;
(b) assigns the names shown in Column 2 to the corporations; and
under section 14B(3) of the Act, appoints the persons listed in Column 3 to be Chairpersons of the corporations.

SCHEDULE

Column 1 Reserve details	Column 2 Corporate name	Column 3 Chairperson
Fairfield Recreation Reserve The land in the Parish of Enfield temporarily reserved for public recreation by Order in Council of 4 September 1963. (Rs 8246)	Enfield Recreation Reserve Committee of Management	Sue Butcher
Point Danger Frontage Reserve That part of the land in the Township of Portland and Parish of Portland temporarily reserved for public purposes by Order in Council of 11 August 1879 as is situated between the points marked "A" to "B" on the plan numbered "P/1.2.98" attached to Department of Natural Resources and Environment correspondence No Rs 2362. Crown Allotment 42B, Section D, Township of Portland and Crown Allotment 86E, Section 13, Parish of Portland temporarily reserved for public purposes by Order in Council of 22 February 2000. (Rs 43107)	Point Danger Committee of Management Incorporated	Elizabeth King
Wairewa Public Hall and Recreation Reserve Crown Allotment 1A, Section A, Parish of Nowa Nowa South temporarily reserved for a public hall and recreation by Order in Council of 18 October 1983. (Rs 12227)	Wairewa Public Hall and Recreation Reserve Committee of Management Incorporated	John Appleby

This Order is effective from the date on which it is published in the Government Gazette.
Dated: 11 April 2000.

Responsible Minister
SHERRYL GARBUTT
MINISTER FOR ENVIRONMENT AND CONSERVATION

STACEY ROBERTSON
Acting Clerk of the Executive Council

Cemeteries Act 1958

SCALE OF FEES

Under Section 17(1) of the **Cemeteries Act 1958**, and on the recommendation of the Minister for Health, the Lieutenant-Governor as the Governor's deputy, with the advice of the Executive Council consents to the making of the Scales of Fees in respect of the following Public Cemeteries:

Boroondara

Cemeteries Act 1958

SCALE OF FEES

By resolution of the Trust, the following fees will apply in the Boroondara Public Cemetery from the date of approval by the Lieutenant-Governor as the Governor's deputy. All other fees are rescinded to the extent to which they conflict with this scale.

MAUSOLEUM CRYPT FEES

LEVEL	A	B	C	D	E
	\$	\$	\$	\$	\$
EXTERIOR					
Singles	15,500	19,600	18,200	15,500	10,800
INTERIOR ORDINARY					
Singles	20,300	25,700	23,900	20,300	14,000
Tandems	28,600	36,200	33,600	28,600	19,800
INTERIOR SPECIAL					
Singles	24,000	32,000	29,500	25,000	17,200
Slide Overs	45,500	55,000	51,500	45,700	29,900

GRANITE NICHE 25 year tenure

LEVELS	A B G H I J	C D E F
EXTERIOR	1,400	1,500
INTERIOR		
Passage	1,900	2,050
South Wall	2,050	2,200
West Wall	2,050	2,200
Window	2,250	2,400

N.B. GOODS AND SERVICES TAX ADDITIONAL FROM DUE DATE.

CHARLES HARKIN, trustee

LINDSAY JOHN FAHEY, trustee

GREG FORRISTAL, trustee

Dated 4 April 2000.

Responsible Minister:
HON JOHN THWAITES MP
Minister for Health

STACEY ROBERTSON
Acting Clerk of the Executive Council

**SUBORDINATE LEGISLATION ACT 1994
NOTICE OF MAKING OF STATUTORY
RULES**

Notice is hereby given under Section 17 (2) of the **Subordinate Legislation Act 1994** of the making of the following Statutory Rules:

27. *Statutory Rule:* Magistrates' Court
General (Amendment)
Regulations 2000
Authorising Act: Magistrates' Court
Act 1989
Date of making: 11 April 2000

**SUBORDINATE LEGISLATION ACT 1994
NOTICE THAT STATUTORY RULES ARE
OBTAINABLE**

Notice is hereby given under Section 17 (3) of the **Subordinate Legislation Act 1994** that the following Statutory Rules were first obtainable from Information Victoria, 356 Collins Street, Melbourne on the date specified:

25. *Statutory Rule:* Architects
(Amendment)
Regulations 2000
Authorising Act: Architects Act 1991
Date first obtainable: 10 April 2000

Code A

26. *Statutory Rule:* Children and Young
Persons (Children's
Court) (Amendment)
Regulations 2000

Authorising Act: Children and Young
Persons Act 1989
Date first obtainable: 13 April 2000

Code A

Retail price will vary according to the number of pages in each special or periodical gazette. The table below sets out the prices that apply

<i>Price Code</i>	<i>No. of Pages (Including cover and blank pages)</i>	<i>Price</i>
A	1-16	\$2.90
B	17-32	\$4.30
C	33-48	\$5.90
D	49-96	\$9.15
E	97-144	\$11.85
F	145-192	\$14.00
G	193-240	\$16.15
H	241-288	\$17.20
I	289-352	\$19.35
J	353-416	\$22.60
K	417-480	\$25.80
L	481-544	\$30.10
M	545-608	\$34.40
N	609-672	\$38.70
O	673-736	\$43.00
P	737-800	\$47.30

ADVERTISERS PLEASE NOTE

As from 13 April 2000

The last Special Gazette was No. 44
dated 11 April 2000

The last Periodical Gazette was No. 2
dated 28 October 1999

CONTENTS

	Page
Estates of Deceased Persons	680
Government and Outer Budget Sector	
Agencies Notices	724
Orders in Council—	742
Acts — Control of Weapons; Forests; Land; Crown Land (Reserves); State Aid to Religion Abolition	
Private Advertisements	680
Proclamations	723

The Victoria Government Gazette is published by The Craftsman Press Pty. Ltd. with the authority of the Government Printer for the State of Victoria
© State of Victoria 2000

ISSN 0819-5471

This publication is copyright. No parts may be reproduced by any process except in accordance with the provisions of the Copyright Act.

Products and services advertised in this publication are not endorsed by The Craftsman Press Pty. Ltd. or the State of Victoria and neither of them accepts any responsibility for the content or the quality of reproduction. The Craftsman Press Pty. Ltd. reserves the right to reject any advertising material it considers unsuitable for government publication.

Address all enquiries to the Government Printer for the State of Victoria
Government Information and Communications Branch
Department of Premier and Cabinet
Level 3, 356 Collins Street
Melbourne 3000
Victoria Australia

RETAIL SALES

Information Victoria Bookshop
356 Collins Street Melbourne 3000.
Telephone enquiries 1300 366 356

City Graphics
Level 1, 520 Bourke Street
Melbourne 3000
Telephone enquiries (03) 9600 0977

Recommended Retail Price \$1.70

Government and Outer Budget Sector Agencies please note:
STYLE REQUIREMENTS.

To ensure that material received can be reproduced, and that errors are minimised, the following guidelines are to be observed when submitting material by fax.

Fax resolution:

Material sent by fax should be transmitted using Fine Resolution (200 dots per inch by 200 dpi).

Font size:

Use 12 point (10 pitch) or larger.

Font Style:

Clear plain font styles, such as Helvetica, should be used.

Graphics:

Line drawings should be transmitted as large as possible to ensure clarity. Drawings up to A4 size sent by fax using Fine Resolution provide a good quality for reproduction.

Avoid:

Italics, underlining and full justification.

Ensure document is square when sending as documents that are sent skewed are difficult to read and process.

ISSN 0819-5471

