



Victoria Government Gazette

No. G 42 Thursday 18 October 2001

GENERAL

GENERAL AND PERIODICAL GAZETTE

Copy to: Gazette Officer
The Craftsman Press Pty. Ltd.
125 Highbury Road,
Burwood Vic 3125
Telephone: (03) 9926 1233
Facsimile: (03) 9926 1292
DX: 32510 Burwood
Email: gazette@craftpress.com.au

Advertising Rates and Payment

All prices include GST

Private Notices

Payment must be received in advance with advertisement details.

33 cents per word – Full page \$198.00.

Additional costs must be included in prepayment if a copy of the gazette is required. Copy Prices – Page \$1.65 – Gazette \$3.52 – Certified copy of Gazette \$3.85 (all prices include postage). *Cheques should be made payable to The Craftsman Press Pty. Ltd.*

Government and Outer Budget Sector Agencies Notices

Not required to prepay.

Advertisements may be faxed or sent via email with a cover sheet, marked to the attention of the Gazette Officer. Floppy Disks (Mac & PC) can also be accepted.

Costs can be calculated on the following basis:

Per Line	Typeset
Single column	\$1.71
Double column	\$3.41
Full Page	\$71.28

The Craftsman Press is pleased to offer a series of discounts from the typesetting costs.

1. Copy supplied on disk.
2. Copy supplied via email.
3. Artwork for forms and other material which require exact reproduction.

1. Copy supplied on disk.

Where a disk is supplied and there is minimum alteration required, **30% off.**

Where a disk is supplied requiring extraneous matter stripped out and styles applied, **20% off.**

2. Copy supplied via email.

Where a notice is sent via email and there is minimum alteration required, **25% off.**

Where email is supplied requiring extraneous matter stripped out and styles applied, **15% off.**

3. Artwork for forms and other material which requires exact reproduction.

Scanning and sizing of artwork for forms, to be reproduced in page format, **35% off.**

Copy Deadline for General Gazette

9.30 a.m. Monday – (Private Notices)

9.30 a.m. Tuesday – (Government and Outer Budget Sector Agencies Notices)

Advertisers should note:

- Late copy received at The Craftsman Press Pty. Ltd. after deadlines will be placed in the following issue of VGG, irrespective of any date/s mentioned in the copy (unless otherwise advised).
- Proofs will be supplied only when requested or at the direction of the Gazette Officer.
- No additions or amendments to material for publications will be accepted by telephone.
- Orders in Council may be lodged prior to receiving assent with the Governor's or Clerk's signature. They will only be published once approved and signed.
- Government and Outer Budget Sector Agencies please note: *See style requirements on back page.*

SPECIAL GAZETTES

Copy to: Gazette Officer
The Craftsman Press Pty. Ltd.
125 Highbury Road
Burwood Vic 3125
Telephone: (03) 9926 1233
Facsimile: (03) 9926 1292
Email: gazette@craftpress.com.au

Advertising Rates and Payment

Private Notices

Full Page \$396.00

Payment must be received in advance with notice details.

Government and Outer Budget Sector Agencies Notices

	Typeset
Full Page	\$96.25

Note:

The after hours number for Special Gazettes is:
Telephone: 0419 327 321

SUBSCRIPTIONS AND RETAIL SALES

Copies of the *Victoria Government Gazette* can be purchased from The Craftsman Press Pty. Ltd. by subscription.

The *Victoria Government Gazette*

General and Special – \$187.00 each year

General, Special and Periodical – \$249.70 each year

Periodical – \$124.30 each year

Subscriptions are payable in advance and accepted for a period of one year. All subscriptions are on a firm basis and refunds will not be given.

All payments should be made payable to The Craftsman Press Pty. Ltd.

Subscription enquiries:

The Craftsman Press Pty. Ltd.
125 Highbury Road, Burwood Vic 3125
Telephone: (03) 9926 1233

INDEX TO PRIVATE ADVERTISERS

A

A.B. Natoli Pty2624
Aitken Walker & Strachan2624
Aughtersons2624

B

Bruce M. Cook & Associates2624

D

Dwyer Mahon & Robertson2624

E

Eales & MacKenzie2625
Ellinghaus Weill2625

G

Garden & Green2625
G.W.H. Chambers2625

J

James Hopper2625

K

Kelly & Chapman2625

L

L.K. Donaldson & Co.2626

M

Mills Oakley2626

P

Patricia M. Melville2626
Perpetual Trustees Victoria Ltd2626

R

Rennick & Gaynor2626
Roberts Partners2627

S

Stidson & Williams Weblaw2627

**PUBLICATION OF THE VICTORIA
GOVERNMENT GAZETTE (GENERAL)
MELBOURNE CUP HOLIDAY**

PLEASE NOTE:

The Victoria Government Gazette for Melbourne Cup week will be published on Thursday 8 November 2001. All copy for Private Advertisements must reach the Government Gazette Office by no later than 9.30 am on Friday 2 November 2001. All copy for Government and Outer Budget Sector Agencies Advertisements must reach the Government Gazette Office by no later than 9.30 am on Monday 5 November 2001

Where urgent gazettal is required after hours, arrangements should be made with the Government Gazette Officer on 0419 327 321.

David Taylor
Government Gazette Officer

PRIVATE ADVERTISEMENTS

DISSOLUTION OF PARTNERSHIP

Notice is hereby given that the partnership subsisting between Anthony Francis Riordan, Paul Francis Hesse and Simon John Jay, who carried on business as partners in the law firm, Riordans Solicitors at Level 2, 501 La Trobe Street, Melbourne 3000 under the registered business name Riordans, has been dissolved by mutual consent on and from 30 September 2001. Dated 8 October 2001

Signed by:
A. F. RIORDAN
P. F. HESSE
S. J. JAY

JAMES HENRY GREEN, late of 84 Gipps Crescent, Cranbourne, Victoria, retired, deceased. Creditors, next-of-kin and others having claims in respect of the estate of the abovenamed deceased, who died on 17 March 2001, are required by Vincent Paul Green of 84 Gipps Crescent, Cranbourne, Victoria, retailer, the executor of the deceased's will, to send particulars of their claim to the said executor care of the undermentioned solicitors by 24 December 2001 after which date they will convey or distribute the assets having regard only to the claims of which they then have notice.

A. B. NATOLI PTY., solicitors
24 Cotham Road, Kew 3101.

CHRISTIAN OLAF OLSEN, late of 5 Dunraven Avenue, Toorak, Victoria, retired, deceased. Creditors, next-of-kin and others having claims in respect of the estate of the deceased, who died on 26 June 2001, are required by the executor, Harry Meares Hearn of 114 William Street, Melbourne, to send particulars to him care of the undermentioned solicitors by 13 December 2001 after which date the executor may convey or distribute the assets having regard only to the claims of which he then has notice.

AITKEN WALKER & STRACHAN,
solicitors,
114 William Street, Melbourne 3000.

MARIA PETRONELLA VAN EGMOND, late of 21 Orange Grove, Bayswater, home duties, deceased. Creditors, next-of-kin and

others having claims in respect of the estate of the abovenamed deceased, who died on 3 November 2000, are required by the executors, Sophia Johanna Van Egmond and Donald Leonard Minett of 398 Lonsdale Street, Melbourne, Victoria, to send particulars thereof to them care of the office of Messrs Aughtersons, solicitors, 267 Maroondah Highway, Ringwood within 60 days of the date of publication of this notice after which date the executors will distribute the estate having regard only to the claims of which they have notice.

AUGHTERSONS, solicitors for the applicant,
267 Maroondah Highway, Ringwood 3134.

Re: Estate GEORGE NEWTON HUGHES, deceased. Creditors, next-of-kin or others having claims in respect of the estate of GEORGE NEWTON HUGHES, late of Room 29, Gaffney House, Lynden Street, Camberwell, in the State of Victoria, investor, who died on 21 May 2001, are to send particulars of their claims to the personal representative care of the undermentioned solicitors by 27 December 2001 after which date the personal representative will distribute the assets having regard only to the claims of which they then had notice.

BRUCE M. COOK & ASSOCIATES,
barristers & solicitors,
Level 4, St James Building,
121 William Street, Melbourne, Vic. 3000.

Re: Estate of HUGH MELVILLE BISSELL. Creditors, next-of-kin or others having claims in respect of the estate of HUGH MELVILLE BISSELL, formerly of 6 Chisholm Street, Swan Hill, in the State of Victoria, optician, but late of Alcheringa Hostel, 44 Rutherford Street, Swan Hill, in the State of Victoria, retired optician, deceased, who died on 15 August 2001, are to send particulars of their claim to the executors care of the undermentioned legal practitioners by 20 December 2001 after which date the executors will distribute the assets having regard only to the claims of which they then have notice.

DWYER MAHON & ROBERTSON,
legal practitioners
Beveridge Dome,
194-208 Beveridge Street, Swan Hill.

Re: Estate of VALDA JEAN HUGHES. Creditors, next-of-kin or others having claims in respect of the estate of VALDA JEAN HUGHES, formerly of Ultima Road, Culgoa but late of 234/67 Maroondah Highway, Croydon, in the State of Victoria, widow, deceased, who died on 26 June 2001, are to send particulars of their claim to the executors care of the undermentioned legal practitioners by 20 December 2001 after which the executors will distribute the assets having regard only to the claims of which they then have notice.

DWYER MAHON & ROBERTSON,
legal practitioners,
Beveridge Dome,
194–208 Beveridge Street, Swan Hill.

Re: ENNO HOFFMAN, late of 13 Montpellier Street, Healesville 3777, but formerly of Lot 19 Montpellier Street, Healesville, transport manager, deceased. Creditors, next-of-kin and others having claims in respect of the estate of the deceased, who died on 15 July 2001, are required by the trustee, Lawrence Campbell Bennett of 17 Montpellier Street, Healesville, Victoria, company director, friend, to send particulars to the trustee by 19 December 2001 after which date the trustee may convey or distribute the assets, having regard only to the claims of which the trustee then has notice.

EALES & MACKENZIE, solicitors,
142 Main Street, Lilydale 3140.

WILLIAM CORNELIUS LAWRENCE DALY, (in the will called William Cornelius Daly), late of 7 Lobb Street, Bendigo, retired publican, deceased. Creditors, next-of-kin and others having claims in respect of the estate of the deceased, who died on 14 March 2001, are required by the personal representatives, Wayne Michael John Daly of 87 Lucan Street, Bendigo and Garry William Lawrence Daly of 5 Maxwell Street, Kyneton, to send particulars to them care of the undermentioned solicitors by 26 December 2001 after which date the personal representatives may convey or distribute the assets having regard only to the claims of which they then have notice.

ELLINGHAUS WEILL, solicitors,
79–81 Franklin Street, Melbourne 3000.

Re: BRUCE WILLIAM WATSON, late of 80 Dillon Street, Ultima, Victoria, retired shearing contractor, deceased. Creditors, next-of-kin and others having claims in respect of the estate of the deceased, who died on 12 June 2001, are required by the trustees, Shane William Watson and Ashley Bruce Watson, to send particulars to them care of the undermentioned solicitors by 26 December 2001 after which date the trustees may convey or distribute the assets having regard only to the claims of which they have notice.

GARDEN & GREEN, solicitors,
4 McCallum Street, Swan Hill 3585.

JOYCE ATHALLA ANASTASIA MALLON, late of McKinnon Private Nursing Home, 97 Wheatley Road, McKinnon. Creditors, next-of-kin and others having claims in respect of the estate of the deceased, who died on 21 August 2001, are required by the trustee, care of G.W.H. Chambers solicitor of 338 Charman Road, Cheltenham, to send particulars to him by 19 December 2001 after which date the trustee may convey or distribute the assets, having regard only to the claims of which he then has notice.

Date 18 October 2001
G.W.H. CHAMBERS, solicitor,
338 Charman Road, Cheltenham, 3192.

JOYCE MARGARET GUNNING, late of Doncaster Melaleuca Lodge, 395 Manningham Road, Doncaster, widow, deceased. Creditors, next-of-kin and others having claims in respect of the estate of the abovenamed deceased, who died on 25 July 2001, are required to send particulars of their claims to the executors, David Joseph Gunning and Alex Susan Grace Caldwell, care of the undernoted solicitor by 20 December 2001 after which date they will convey or distribute the assets having regard only to the claims of which they then have notice.

JAMES HOPPER, solicitor,
409 Whitehorse Road, Balwyn.

Creditors, next-of-kin and others having claims in respect of the estate of CLYDIE ASHFORTH, late of 6 Freeman Street, Caulfield South in the State of Victoria, widow, deceased, who died on 27 September 2001, are

required by the executors nominated in the deceased's last will and testament dated 18 August 1997 and the codicil dated 21 March 1999 namely Peter Leslie Clive Ashforth of Boyle Swamp Road, Mylor in the State of South Australia, psychiatrist and Catherine Anne Rodgers of 33 Hillview Road, Mount Waverley in the State of Victoria, teacher, to send particulars of such claims to the solicitors acting for the said executor namely Kelly & Chapman, 437 Centre Road, Bentleigh by 27 December 2001 after which date the said executors may convey or distribute the assets of the deceased, having regard only to the claims of which they or their solicitors then have notice.

KELLY & CHAPMAN,
437 Centre Road, Bentleigh.

PATRICIA MARLON GUEST, late of 163 Kooyong Road, Toorak, Victoria, widow, deceased. Creditors, next-of-kin and others having claims in respect of the estate of the deceased, who died on 8 January 2001, are required by the executor, James Vincent Chester Guest of 24 Jolimont Terrace, Jolimont, Victoria, to send particulars to him by 21 December 2001 after which date he may convey or distribute the assets having regard only to the claims of which he then has notice.

L. K. DONALDSON & CO., lawyers,
Level 4, 477 Collins Street, Melbourne.

Estate of BENJAMIN JOHN WILLIS. Creditors, next-of-kin and others having claims in respect of the estate of BENJAMIN JOHN WILLIS, deceased, late of 13 Langs Road, Ascot Vale, Victoria, retired teacher, (who died on 8 September 2001), are required by the deemed executor, ANZ Executors & Trustee Company Limited of 530 Collins Street, Melbourne, Victoria, to send particulars to it by 18 December 2001 after which date it may convey or distribute the assets having regard only to the claims of which it then has notice.

MILLS OAKLEY, lawyers,
131 Queen Street, Melbourne.

Estate of LINDA LILLIAN BREW. Creditors, next-of-kin and others having claims in respect of the estate of LINDA LILLIAN BREW, deceased, late of Unit 7, 15-19 Dobell Drive, Chelsea, Victoria, home duties, (who died on 17 September 2001), are required

by the executor, ANZ Executors & Trustee Company Limited of 530 Collins Street, Melbourne, Victoria, to send particulars to it by 16 December 2001 after which date it may convey or distribute the assets having regard only to the claims of which it then has notice.

MILLS OAKLEY, lawyers,
131 Queen Street, Melbourne.

Re: MARGARET HELEN CALDER, late of 2 Berwick Street, Camberwell, Victoria, retired social worker, deceased. Creditors, next-of-kin or others having claims in respect of the estate of the abovenamed deceased, who died on 16 July 2001, are required by the trustees, William Patrick Melville and Jennifer Anne Sedgwick, to send particulars to the trustees care of the undermentioned solicitor by 20 December 2001 after which date the trustees may convey or distribute the assets having regard only to the claims of which the trustees then have notice.

PATRICIA M. MELVILLE,
barrister & solicitor,
27 Regent Street, Mount Waverley 3149.

LESLIE WALTER BUNKER, late of Gregory Lodge Nursing Home, 2-58 Newmarket Street, Flemington, Victoria 3031, formerly of 489 Station Street, North Carlton, Victoria. Creditors, next-of-kin and others having claims in respect of the estate of the deceased, who died on 14 May 2001, are required by Perpetual Trustees Victoria Limited, ACN 004 027 258 of 360 Collins Street, Melbourne, Victoria, to send particulars of their claims to the said company by 19 December 2001 after which date it will convey or distribute the assets having regard only to the claims of which the company then has notice.

THOMAS LIVESLEY PHILLIPS, late of 68 Wimborne Avenue, Mount Eliza, Victoria 3930, formerly of 36143. Creditors, next-of-kin and others having claims in respect of the estate of the deceased, who died on 6 June 2001, are required by Perpetual Trustees Victoria Limited, ACN 004 027 258 of 360 Collins Street, Melbourne, Victoria, to send particulars of their claims to the said company by 19 December 2001 after which date it will convey or distribute the assets having regard only to the claims of which the company then has notice.

Creditors, next-of-kin and others having claims in respect of the estate of LEILA MARY GIBSON, late of Trentham Bush Hostel, 22-24 Victoria Street, Trentham, Victoria, home duties, deceased, who died on 7 April 2001, are to send particulars of their claims to Lynne Michelle Gibson and David Anthony Rush, the executors appointed by the will, care of the undersigned by 18 December 2001 after which date they will commence to distribute the assets having regard only to the claims of which they then have notice.

RENNICK & GAYNOR, solicitors,
431 Riversdale Road, Hawthorn East.

Creditors, next-of-kin and others having claims in respect of the estate of MARGARET MARY ROSE ATKINSON, late of 1266 Centre Road, Clayton, Victoria, retired, deceased, who died on 21 July 2001, are to send particulars of their claims to Michael Anthony Atkinson, the proving executor appointed by the will care of the undermentioned by 18 December 2001 after which date he will commence to distribute the assets having regard only to the claims of which he then has notice.

RENNICK & GAYNOR, solicitors,
431 Riversdale Road, Hawthorn East.

Re: IAN THOMAS FITZPATRICK, late of 126 Maxwell Street, Mornington, fitter and turner, deceased. Creditors, next-of-kin or others having claims in respect of the estate of the deceased, who died on 14 August 2001 are required by the trustee, Geraldine Margaret Harvey in the will called Geraldine M. Harvey of 128 Maxwell Street, Mornington, Victoria, home duties, to send particulars to the trustee by 19 December 2001 after which date the trustee may convey or distribute the assets, having regard only to the claims of which the trustee then has notice.

ROBERTS PARTNERS,
216 Main Street, Mornington.

ENID RUTH ARCHBOLD, late of 20 Irving Street, Mount Waverley, Victoria, deceased. Creditors, next-of-kin and others having claims in respect of the estate of the deceased, who died on 5 June 2001, are required by the trustee, Carolyn Elizabeth Dornbusch of P.O. Box 123,

Mount Eliza, Victoria, to send particulars to her by 15 December 2001 after which date the trustee may convey or distribute the assets having regard only to the claims of which she then has notice.

STIDSTON & WILLIAMS WEBLAW,
solicitors,
313 Main Street, Mornington.

In the Supreme Court of the State of Victoria
SALE BY THE SHERIFF

To the Highest Bidder at the Best Price Offered

On 22 November 2001 at 2.30 p.m. at the Sheriff's Office, 8-20 King Street, Oakleigh, (unless process be stayed or satisfied).

All the estate and interest (if any) of Dong Van Nguyen of 133 Foote Street, Templestowe, joint proprietor with Thanh Tam Duong of an estate in fee simple in the land described on Certificate of Title Volume 8845, Folio 862, upon which is erected a house known as 133 Foote Street, Templestowe.

Registered Mortgage No. R752821F affects the said estate and interest.

No Reserve Set
Terms – Cash only
SW-00-007660-4

Dated 18 October 2001

S. BLOXIDGE
Sheriff's Office

In the Supreme Court of the State of Victoria
SALE BY THE SHERIFF

On 22 November 2001 at 2.30 p.m. at the Sheriff's Office, 8-20 King Street, Oakleigh, (unless process be stayed or satisfied).

All the estate and interest (if any) of Brenchley Gardens Pty Ltd (ACN 006 299 538) of 3 Rosecraddock Place, Caulfield North, proprietor of an estate in fee simple in one equal undivided half part or share in the land described on Certificate of Title Volume 9810, Folio 652 with Landro Pty Ltd., proprietor as tenant in common in equal shares in the land described on Certificate of Title Volume 7375, Folio 861, upon which is erected a dwelling known as one Rosecraddock Place, Caulfield North.

The Statutory Charge No. U918407L and covenant contained in Transfer 2152291 affect the said estate and interest.

Terms – Cash only

SW-01-004803-6

Dated 18 October 2001

S. BLOXIDGE
Sheriff's Office

In the Supreme Court of the State of Victoria

SALE BY THE SHERIFF

On 22 November 2001 at 2.30 p.m. at the Sheriff's Office, 8-20 King Street, Oakleigh, (unless process be stayed or satisfied).

All the estate and interest (if any) of Antonios Amanatidis of 13 Adaleigh Street, Yarraville, as shown on Certificate of Title as Tony Amanatidis, joint proprietor with Georgina Amanatidis of an estate in fee simple in the land described on Certificate of Title Volume 6046, Folio 127, upon which is erected a dwelling known as 13 Adaleigh Street, Yarraville.

Registered Mortgage Nos. U595296E, W431543F and Caveat Nos. W763974F, X501157P, X575295T affect the said estate and interest.

Terms – Cash only

SW-01-008418-2

Dated 18 October 2001

S. BLOXIDGE
Sheriff's Office

In the Supreme Court of the State of Victoria

SALE BY THE SHERIFF

On 22 November 2001 at 2.30 p.m. at the Sheriff's Office, 8-20 King Street, Oakleigh, (unless process be stayed or satisfied).

All the estate and interest (if any) of Mohamed Firdavs Khan of 14 Wren Street, Hampton Park as shown on Certificate of Title as Mohammad Firdaus Khan proprietor of an estate in fee simple in the land described on Certificate of Title Volume 8408, Folio 316, upon which is erected a double storey house known as 14 Wren Street, Hampton Park.

Registered Mortgage No. U751480G affects the said estate and interest.

Terms – Cash Only

SW-00-010902-2

Dated 18 October 2001

S. BLOXIDGE
Sheriff's Office

In the Supreme Court of the State of Victoria

SALE BY THE SHERIFF

On 22 November 2001 at 2.30 p.m. at the Sheriff's Office, 8-20 King Street, Oakleigh, (unless process be stayed or satisfied).

All the estate and interest (if any) of Wayne Whiteoak of 6 Harlow Court, Deer Park as shown on Certificate of Title as Wayne John Whiteoak, joint proprietor with Jovelyn Coma Whiteoak, of an estate in fee simple in the land described on Certificate of Title Volume 9216, Folio 337 upon which is erected a house known as 6 Harlow Court, Deer Park.

Registered Mortgage No. N520047N affects the said estate and interest.

Terms – Cash only

SW-00-004348-7

Dated 18 October 2001

S. BLOXIDGE
Sheriff's Office

PROCLAMATIONS

ACTS OF PARLIAMENT

Proclamation

I, John Landy, Governor of Victoria, declare that I have today assented in Her Majesty's name to the following Bills:

No. 55/2001 **Agricultural and Veterinary Chemicals (Control of Use) (Further Amendment) Act 2001**

No. 56/2001 **Business Investigations (Repeal) Act 2001**

No. 57/2001 **Commonwealth Games Arrangements Act 2001**

No. 58/2001 **Crimes (Validation of Orders) Act 2001**

No. 59/2001 **Infertility Treatment (Amendment) Act 2001**

No. 60/2001 **Trustee (Amendment) Act 2001**

Given under my hand and the seal of Victoria at Melbourne on 16 October 2001.

(L.S.) JOHN LANDY
Governor
By His Excellency's Command

STEVE BRACKS
Premier

(2) Subject to sub-section (3), the remaining provisions of this Act come into operation on a day or days to be proclaimed.

(3) If a provision referred to in sub-section (2) does not come into operation before 1 July 2002, it comes into operation on that day.

No. 55/2001 This Act comes into operation on the day after the day on which it receives the Royal Assent.

No. 56/2001 This Act comes into operation on the day after the day on which it receives the Royal Assent.

No. 57/2001 This Act comes into operation on the day after the day on which it receives the Royal Assent.

No. 58/2001 This Act comes into operation on the day after the day on which it receives the Royal Assent.

No. 59/2001 This Act comes into operation on the day after the day on which it receives the Royal Assent.

No. 60/2001 (1) Section 1 and this section come into operation on the day after the day on which this Act receives the Royal Assent.

**GOVERNMENT AND OUTER BUDGET SECTOR AGENCIES
NOTICES**

COLAC OTWAY SHIRE

**Renaming of part of Bottrells Road and Naming an Unnamed Road Gellibrand as
"Old Lardner Track" Gellibrand**

Notice is hereby given that the Colac Otway Shire on 26 September 2001 resolved (in part):—
That Council, having considered submissions received, resolves:

- (a) the initial section of Bottrells Road, extending south east from Gellibrand East Road to the junction of Jacksons Track be renamed as "Old Lardner Track";
- (b) the portion of Bottrells Road extending easterly from the junction of Jacksons Track to the junction of an unnamed road and Bottrells Road be renamed as "Old Lardner Track";
- (c) the unnamed road extending south east from the junction of Bottrells Road as far as Meehans Track be named "Old Lardner Track".

in accordance with the provisions of Clause 5, Schedule 10 of the **Local Government Act 1989**.

This name was assigned after a process of public consultation in accordance with the provisions of the **Local Government Act 1989**.

The name shall take effect from the date of publication of this notice.

A plan showing the location of the road is shown below.

ROAD TO BE NAMED OLD LARDNERS TRACK

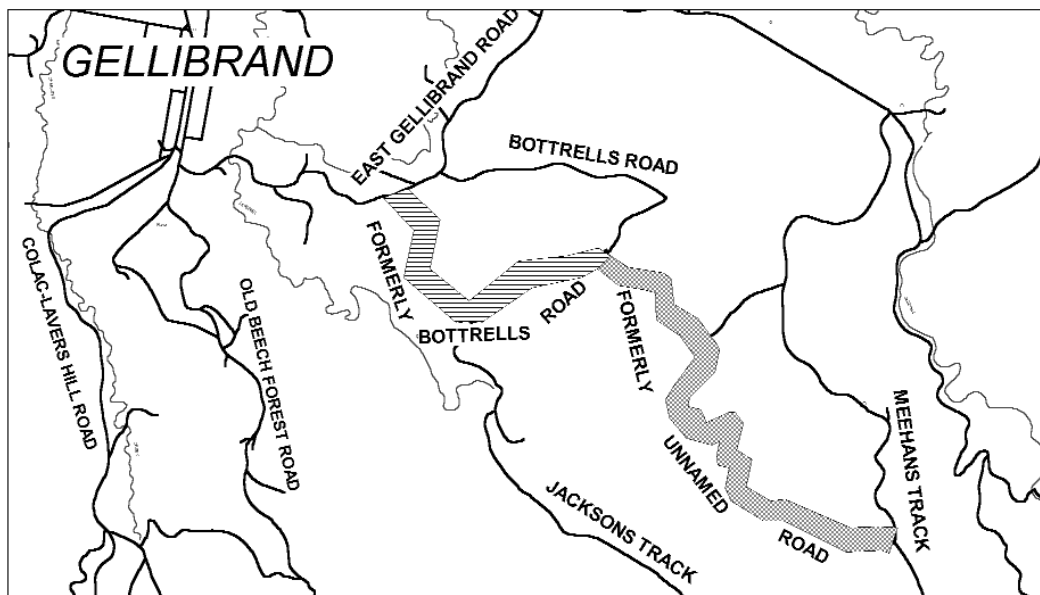

GLENN PATTERSON
Chief Executive Officer

KINGSTON CITY COUNCIL

Road Discontinuance

Pursuant to Section 206 and Schedule 10, Clause 3 of the **Local Government Act 1989**, the Kingston City Council has formed the opinion that the section of road at the rear of 25 Northcliffe Road, Edithvale, and shown by cross-hatching on the plan below, is not reasonably

required as a road for public use and resolved to discontinue the road and to sell the land from the road by Private Treaty to the abutting property owner.

The section of road is to be sold subject to the right, power or interest held by South East Water Limited and the City of Kingston in the road in connection with any sewers, drains or pipes, under the control of those authorities in or near the road.

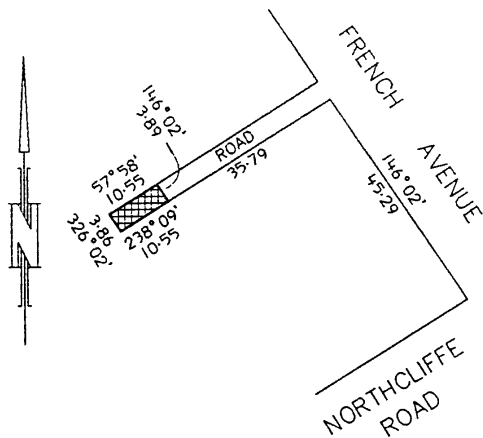

ROB SKINNER
Chief Executive Officer



LOCAL LAW NO. 3A –
MEETING PROCEDURE LOCAL LAW

Notice is hereby given pursuant to section 119(3) of the **Local Government Act 1989** that at a meeting of the Boroondara City Council held on 8 October 2001, the Council resolved to make Local Law No. 3A – Meeting Procedure Local Law.

The purpose of the Local Law is to:

- regulate the use of the common seal;
- prohibit unauthorised use of the common seal or of any device resembling the common seal;
- provide for the election of the Mayor; and
- provide for the procedures governing the conduct of Council meetings, Special Committee meetings and other meetings conducted by or on behalf of Council.

The Local Law:

- regulates the use and control of the Council's common seal;

- makes it an offence to use the Council's common seal without authority;
- regulates the procedure for the election of the Mayor;
- regulates the meetings of the Council (including Ordinary and Special Meetings) in a number of respects, including provisions dealing with quorums, order of business, notices of motion, notices of rescission, addressing the meeting, public question time, public behaviour, petitions, voting, motions, points of order, duties and discretions of the Chairperson, minutes, suspension of standing orders and Special and Advisory Committees;
- makes it an offence, where a person is guilty of improper or disorderly conduct, to fail to leave the Chamber when requested by the Chairperson; and
- makes it an offence to fail to comply with a direction of the Chairperson in relation to the conduct of the meeting and the maintenance of order.

A copy of the Local Law may be inspected or obtained during normal business hours at the following locations: Camberwell Office, 8 Inglesby Road, Camberwell. Telephone: 9278 4444; Hawthorn Office, 360 Burwood Road, Hawthorn. Telephone: 9278 4444; Kew Customer Service Centre, Civic Drive, Kew. Telephone: 9278 4444; Ashburton Library, 154 High Street, Ashburton. Telephone: 9278 4633; Balwyn Library, 336 Whitehorse Road, Balwyn. Telephone: 9278 4644; Camberwell Library, 360 Camberwell Road, Camberwell. Telephone: 9278 4655; Hawthorn Library, 584 Glenferrie Road, Hawthorn. Telephone: 9278 4666; Kew Library, Civic Drive, Kew. Telephone: 9278 4677.

JOHN NEVINS
Director Works & Governance



NOTICE OF MAKING LOCAL LAW 7 –
ENVIRONMENT

Notice is hereby given that the Wodonga Rural City Council, at its meeting on 8 October 2001, resolved to make Local Law No. 7 – Environment, pursuant to the provisions of Part 5 of the **Local Government Act 1989**.

The purpose and general purport of this Local Law is as follows:

Local Law 7 – Environment

- a) to enhance public safety and community amenity within the Municipal District; and
- b) to prohibit, regulate and control activities which may be dangerous or unsafe or detrimental to the quality of life in an environment of the municipal district; and
- c) to facilitate the provision of general public services, health and other community services, property services, recreational and cultural services, and other services in a way which enhances the environment and quality of life in the municipal district; and
- d) to control nuisances and noise, odour and smoke emissions, and other discharges to the environment which may adversely affect the enjoyment of life within the municipal district or the health, safety and welfare of persons within the municipal district; and
- e) in a way which is consistent with, and in furtherance of, the objectives specified in paragraphs (a) to (d) of this clause to prohibit, regulate and control activities and circumstances associated with:–
 1. smoke emission, particularly emission from burning material; and
 2. the use of recreational vehicles, particularly recreational vehicles which are not used on appropriate land or reserves or which emit excessive noise or air pollution; and
 3. dangerous and unsightly land; and
 4. advertising and bill posting; and
 5. camping; and
 6. animals, including animal numbers and the keeping and control of animals; and
 7. disposal of waste including behaviour associated with tips; and
- f) to provide for the peace, order and good government of the municipal district; and
- g) to provide for the administration of Council's powers and functions; and
- h) to revoke Local Law No. 4 – Environment.

A copy of the Local Law may be inspected at or obtained from the Council Offices, Customer Service Desk, 90 Hovell Street, Wodonga.

PETER MARSHALL
Chief Executive Officer

Planning and Environment Act 1987

ALPINE PLANNING SCHEME

Notice of Amendment

Amendment C5

The land affected by the amendment is:

- a. Crown land adjacent to CA 1A, Sec 4, Parish of Porepunkah, Back Porepunkah Road, Porepunkah.
- b. Crown land north of Lot 3 PS 304861, CA 1A, Sec 17, Parish of Myrtleford, Buffalo River Road, Myrtleford.
- c. CA 8B, Sec A, Township of Bright, Riverside Avenue, Bright.
- d. CA 5A, Sec 5, Township of Bright, Toorak Road, Bright.
- e. Crown land east of CA 15W1, Sec C, Parish of Bright, Great Alpine Road (Delaney Avenue), Bright.
- f. Crown land south of CA 5, Sec 8, Parish of Harrierville, Great Alpine Road, Harrierville.
- g. CA 30A, Sec P, Parish of Myrtleford, off Buffalo River Road, Myrtleford.
- h. CA 68G, No Sec, Township of Wandiligong, Wandiligong Road, Wandiligong.
- i. CA 68D No Sec, Township of Wandiligong, Wandiligong and Williams Roads, Wandiligong.
- j. CA 1B, Sec 4, Parish of Porepunkah, Roberts Creek Road, Porepunkah.
- k. CA 11, Sec 16, Parish of Bright, off Growlers Creek Road, Wandiligong.
- l. CA 9B, Sec H, Township of Bright, Canyon Lane, Bright.
- m. Myrtleford Garbage Depot, Part Lot 2 LP 127125, Parish of Myrtleford Morrison Lane, Myrtleford.

The Amendment proposes to remove Crown land and local government land from public use zones and include it in appropriate zones.

You may inspect the Amendment, and any documents that support the Amendment, and the explanatory report about the Amendment, at: Alpine Shire, Council Offices, corner Great Alpine Road and Churchill Avenue Bright 3741; Alpine Shire Customer Service Office, O'Donnell Avenue, Myrtleford 3737; Alpine Shire Customer Service Office, Lakeside Avenue, Mt Beauty 3699; Department of Infrastructure, Planning Information Centre, Upper Plaza, Nauru House, 80 Collins Street, Melbourne 3000 and Department of

Infrastructure, North East Regional Office, 50–52 Clarke Street, Benalla 3672.

This can be done during office hours free of charge.

Any person who may be affected by the Amendment may make a submission to the planning authority.

The closing date for submissions is 16 November 2001. A submission must be sent to the Alpine Shire, PO Box 139, Bright 3741.

ROY HETHERINGTON
Chief Executive Officer

Planning and Environment Act 1987
WHITEHORSE PLANNING SCHEME
Notice of Amendment

Amendment C14

Whitehorse City Council has prepared Amendment C14 to the Whitehorse Planning Scheme at the request of the owners of 104–106, 108–110, and 112–114 Terrara Road, Vermont South.

The Amendment proposes to change the Whitehorse Planning Scheme by including land known as 104–106, 108–110, 112–114 and 116–118 Terrara Road, Vermont South in a Residential 1 Zone (from a Low Density Residential Zone).

The proposed Residential 1 Zone allows Council to consider the following: Subdivision of land to create standard residential allotments. More than one dwelling on a lot. A wider range of discretionary uses.

Under a Residential 1 Zone, a planning permit is not required for a detached dwelling on a lot with an area of more than 300 square metres.

The Amendment can be inspected at: The City of Whitehorse, Planning Office Service Centre, 379 Whitehorse Road, Nunawading.

All City of Whitehorse Customer Service Centres and Libraries.

Department of Infrastructure, Planning Information Centre, Upper Plaza level, Nauru House, 80 Collins Street, Melbourne.

Submissions about the Amendment must be made in writing by Friday 23 November 2001 and sent to: Mr Gerard Gilfedder, Co-ordinator Planning Reform, City of Whitehorse, Locked Bag 2, Nunawading Mail Centre, Vic. 3110.

STEPHEN P. WRIGHT
General Manager, City Development

Planning and Environment Act 1987

DAREBIN PLANNING SCHEME

Notice of Amendment

Amendment C38

The City of Darebin has prepared an Amendment to the Darebin Planning Scheme.

The Amendment affects land formerly known as the Mont Park Psychiatric Hospital, currently known as Springthorpe. The land is located south of Main Drive and east of La Trobe University, in Bundoora.

The Amendment proposes to change the planning scheme by introducing vegetation protection controls into the Darebin Planning Scheme on the subject site.

The Amendment can be inspected at: Urban Development, City of Darebin, 274 Gower Street, Preston 3072 and Department of Infrastructure, Customer Service Centre, Upper Plaza, Nauru House, 80 Collins Street, Melbourne 3000.

Any person or agency who may be affected by the Amendment can make a submission to the City of Darebin. Submissions about the Amendment must be sent to City of Darebin, Strategic Planning Unit, PO Box 91, Preston 3072, by the close of business on 19 November 2001.

Please contact Kim Godi on 9230 4461 with any questions.

JOHN VAN AS
Manager Urban Development

Creditors, next-of-kin and others having claims against the estate of any of the undermentioned deceased persons are required to send particulars of their claims to State Trustees Limited, ACN 064 593 148, 168 Exhibition Street, Melbourne, Victoria 3000, the personal representative, on or before 20 December 2001 after which date State Trustees Limited may convey or distribute the assets having regard only to the claims of which State Trustees Limited then has notice.

BELL, Alan John, late of Caulfield Hospital, 294 Kooyong Road, Caulfield, retired, who died 14 July 2001.

CURRAN, John Patrick, late of Barkly Private Nursing Home, 81 Barkly Street, Bendigo, pensioner, who died 14 August 2001.

FOENANDER, Phyllis Loritta, late of 3-297 St Georges Road, Thornbury, pensioner, who died 4 January 2001.

RYAN, Vida May, late of Mentone & District Private Nursing Home, 7 Collins Street, Mentone, retired, who died 17 August 2001.

SAMUEL, Mary, late of Ashleigh Lodge, 58 Cochrane Street, Brighton, pensioner, who died 15 April 2001.

Dated at Melbourne, 11 October 2001

CATHY VANDERFEEN
Manager, Estate Management
State Trustees Limited

Creditors, next-of-kin and others having claims against the estate of any of the undermentioned deceased persons are required to send particulars of their claims to State Trustees Limited, ACN 064 593 148, 168 Exhibition Street, Melbourne, Victoria 3000, the personal representative, on or before 25 December 2001 after which date State Trustees Limited may convey or distribute the assets having regard only to the claims of which State Trustees Limited then has notice.

BRUCE, Ronald Talbot, formerly of 3/8 Government Road, Frankston but late of Unit 1, RSL Park, Overton Road, Frankston, retired, who died 30 August 2001.

BRUCE, Catherine Crosbie, formerly of Flat 4/73 Mayston Street, East Hawthorn but late of Central Park Aged Care Facility, K15 Raleigh Street, Windsor, pensioner, who died 28 May 2001.

MAXWELL, Evelyn May, late of Flat 11, 2 Henryville Street, St Kilda, retired, who died 18 September 2001.

MOORE, Alan Walter, late of 27 Swanpool Avenue, Chelsea, who died 10 August 2001.

TULLY, Francis James, formerly of 35 Arthur Street, Ashwood but late of RSL Park, Overton Road, Frankston, retired, who died 19 August 2001.

Dated at Melbourne, 16 October 2001

CATHY VANDERFEEN
Manager, Estate Management
State Trustees Limited

Department of Treasury and Finance

SALE OF CROWN LAND
BY PUBLIC AUCTION

Date of Auction: 3 November 2001 at 11.00 a.m. on site.

Reference: 2000-01125.

Address of Property: 36 Victoria Street, Ballarat East.

Crown Description: Crown Allotment 4A, Section O¹, Township of Ballarat East.

Terms of Sale: Deposit 10%, Balance 60 days.

Area: 488m².

Officer Co-ordinating Sale: Garry McKenzie, Garry McKenzie & Associates Pty Ltd., 1st Floor, City Centre Arcade, 315 Sturt Street, Ballarat, Vic. 3350.

Selling Agent: Ballarat Real Estate, corner Sturt & Doveton Streets, Ballarat, Vic. 3550.

LYNNE KOSKY MP
Minister for Finance

Department of Treasury and Finance

SALE OF CROWN LAND
BY PUBLIC AUCTION

Date of Auction: Saturday 17 November 2001 at 12 noon on site.

Reference: 2001/01374.

Address of Property: 6 Fair View Street, Traralgon.

Crown Description: Crown Allotment 48D, Parish of Traralgon, County of Buln Buln.

Terms of Sale: Deposit 10%, Balance 16 January 2002.

Area: 886 m².

Officer Co-ordinating Sale: Peter Hunt, Victorian Government Property Group, Department of Treasury and Finance, 5/1 Treasury Place, Melbourne, Vic. 3002.

Selling Agent: Addison Real Estate, 43 Franklin Street, Traralgon, Vic. 3844.

LYNNE KOSKY MP
Minister for Finance

Adoption Act 1984

Under the functions and powers assigned to me by the Secretary, Department of Human Services under Section 10(2) of the **Community Welfare Services Act 1970** in relation to Section 5 of the **Adoption Act 1984**.

I, Gabrielle Levine, approve the following person under Section 5(1) and Section 5(2) (b) of the Act as approved counsellor for the purposes of Section 35 of the Act.

Sylvia Lemke: Anglicare – Western,
41 Somerville Road, Yarraville 3013.

GABRIELLE LEVINE
Regional Director
Western Metropolitan Region

Associations Incorporation Act 1981

SUB-SECTION 36E(5)

Notice is hereby given that the incorporation of the associations mentioned below will be cancelled in accordance with Section 36E(5) of the **Associations Incorporation Act 1981**.

4th National Nursing Education Conference Organising Committee (Vic.) Inc., A. E. Chirnside Club Inc., Acada Gymnastic Club Inc., Al Watson Ministries Inc., Alberton & District Volleyball Association Inc., Albury/Wodonga Bird Fanciers Society Inc., Albury–Wodonga Sailboard Club Inc., Alpine Racing Inc., Altona Basketball Club Inc., Anatolian Folkloric Association Inc., Australia Mongolia Society Inc., Australian College of Psychiatric Nursing Inc., Australian Financial Markets Association Inc., Australian Macedonian Folk Dancing Association “Georgi (GOCE) Delcev” Inc., Australian Spotted Pony Association Inc., Australian Turkish Theatre Inc., Bairnsdale Indoor Soccer Association Inc., Ballarat Jaycees Inc., Ballarat Scuba Divers Inc., Balnarring Junior Soccer Club Inc., Banana Alley Tourism Precinct Association Inc., Bandidos MG Ballarat Inc., Barwon Child Rights and Maltreatment Association Inc., Barwon State Electricity Commission of Victoria Social Club Inc., Bass District Business Association Inc., Bendigo & District Coin Club Inc., Bendigo Vikings Basketball Club Inc., Box Hill Squash Club Inc., Brankeet Aquatic Club Inc., Brewster Tennis Club Inc., Bridging The Gap Society (Western Region) Inc., Bright Alpine Club Inc., Broadford Youth Club Inc., Building and Construction Industry Training Foundation Inc., Building Science Forum of Australia – Victorian Chapter Inc., Bulgarians – Bulgarian Cultural Society Inc., Bunyip Progress Association Inc., Cambodian Youth Association of Victoria Inc., Campaign For Nuclear Free Food (Vic.) Inc.,

Camps For Y.O.U. (Youth Opportunity and Understanding) Inc., Canary Islands Social Club Inc., Caodaist Association of Victoria Inc., Capel Street Housing Association Inc., Carrum Squash Club Inc., Casa Pro Anziani Association Inc., Caulfield Squash Club Inc., Central Gippsland Development Board Inc., Central Victoria Performing Arts Group Inc., Changes – Youth Resource Centre Inc., Charlton Indoor Cricket Association Inc., Chinese Chefs Society Inc., Chinese Opera Society Inc., Christian Orthodox Brotherhood of St. Mark of Ephesus Inc., Club Carlton Association Inc., Clunes 150 Years Celebration Committee Inc., Cobram Barooga Waterski Club Inc., Colac Region Development Board Inc., Combined Practical Shooters of Australia Inc., Combined Students Legal Service Inc., Committee of Management Sailors Gully Mission Hall Inc., Computer Resources Association Inc., Coolaroo Rovers Football Club Inc., Council for the Practicum in Teacher Education Inc., Cricketers Arms Hotel Social Club Mooroopna Inc., Cultural Tourism Association of Victoria Inc., Dandenong Valley and Western Port Authority Social Club Inc., Dapo-Differently Abled Peoples Organisation Inc., Daylesford Action for Youth Inc., Department of Community Services and Health Social Club Inc., Diamond Creek Tavern Social Golf Club Inc., Doncaster and Templestowe United Residents Association Inc., Dulaang-Bayan Melbourne (Philippine Community Theatre) Inc., East Bentleigh Football Club Inc., East Gippsland Avicultural Group Inc., Eastern Saints Junior Football Club Inc., Elsternwick Hockey Club Inc., Elwood United Soccer Club Inc., Endeavour Hills Youth Housing Group Inc., Erica Community Chest Inc., Eureka Commemorative Society Inc., Euroa Silver Horseshoes Harness Club Inc., Fearon Reserve Redevelopment Association Inc., Fibreglass and Rockwool Insulation Manufacturers Association of Australia Inc., Financial Management Association of Australia Inc., Florina Pre-School and Day Care Centre Inc., Focus-Sunraysia Community Support Association Inc., Footscray City Gymnastics Club Inc., Frankston/Chelsea Youth Housing Sub-Regional Group Inc., G. V. Shooting Sports Association Inc., Geelong Bulldogs Rugby League Club Inc., Geelong Children’s Entertainment Foundation Inc., Geelong Mandolin Ensemble Inc., Geelong Motorcycle

Club Inc., Geelong Regional Palouse Pony Branch Inc., Geelong Tenants Advice Service Inc., Gippsland Regional Chamber of Commerce Inc., Gisborne Kids & Parents Club Inc., Glendal Netball Club Inc., Glenroy Lacrosse Club Inc., Gooram Tennis Club Inc., Greek Community of Rye and Districts Inc., Greek Orthodox Community of Melton and District Inc., Greville Squash Club Inc., Handihelp Early Intervention Program Inc., Helenic Sporting Club Mildura United Inc., Hepburn Daylesford Amateur Squash Association Inc., Horsham Radio Control Car Club Inc., Impact Club of Frankston Inc., Independent Power Producers Association Inc., Inner South District Health Council Inc., International Teams Ministries Australia Inc., Jagajaga Association of Customers Inc., Junior Offshore Group of Victoria Inc., Kalorama Adult Riding Club Inc., Kangaroo Flat Community Project Fund Raising Committee Inc., Kyneton District Runners Inc., Kyneton Shearing Committee Inc., Learmonth Anglers Club Inc., Lesbian Unlimited Inc., Lillydale Connections Inc., Lions Club of Hawthorn Inc., Low Income Network Inc., Mani United Inc., Mansfield Night Netball Association Inc., Medical Aid for El Salvador Inc., Melbourne & Metropolitan Marching Zone Inc., Melbourne Improvisers' Association Inc., Melbourne Mangania Culture Club Inc., Melbourne Softball Association Inc., Melbourne Turkish Women's Association—Melbourne Turk Kadinari Dernegi Inc., Melton Community Bingo Association Inc., Melton Silent Flyers Inc., Mental Health Awareness Appeal Inc., Middle East Soccer Club Inc., Mike—Romeo—Charlie Club Inc., Milawa District Children's Services Group Inc., Miminie & Burri Clinic Bendigo & District Aboriginal Women's & Children's Health Service Inc., Mitta Valley Swimming Pool Association Inc., Modern Filipiniana Models of Victoria Inc., Mont Park Kiosk Inc., Morwell Ambulance Social Club Inc., Mountain District Diving Club Inc., Murray Darling Dressmakers Association Inc., National Association of Overseas Professionals Inc., Netherlands Ex-Servicemen and Women's Association in Australia (Victoria) Inc., Nga Puawai (Maori) Club Inc., North East Field Naturalists Club Inc., North Melbourne and Kensington Football Club Inc., North Suburban Junior Football League Inc., Nunawading Church of Christ Netball Club Inc., Nyah District Youth Group Inc., Oil Industry Industrial Secretariat Inc., Operating Theatre Inc., Organic Growers of South Gippsland Inc., Out Theatre Inc., Oznet Inc., P.A.K. (Parents with Allergy Kids) Support Group Inc., Pakenham Heated Swimming Pool Committee Inc., Parade College Fathers Association Inc., Paynesville Netball Club Inc., Peninsula Budgerigar Society Inc., Performing Arts Productions Inc., Philippine Community House Inc., Philippine Help (Lingap Pinoy) Inc., Platform Speakers Toastmasters Club Inc., Point Lonsdale Boardriders Inc., Port Phillip Toastmaster Club Inc., Portland Bicycle Touring Club Inc., Prahran Hellenic Association Inc., Premier City Marching Association Inc., Preston Pythons Inc., Purnim Football Club Inc., Rainforest Action Group Inc., Reckitt & Coleman Moorabbin Social Club Inc., Recyclers Association of Victoria Inc., Red Lion Hotel Sporting & Social Club Inc., Reveille Inc., Ringwood Table Tennis Club Inc., Road Runners Motor Cycle Tourer Club Inc., Romsey Community Bingo Inc., Rotaract Club of Bairnsdale/Riviera Inc., Rural Womens Outlook Inc., Rye Sports & Social Club Inc., Sale Parent Educators' Group Inc., Sale Post Natal Depression Support Group Inc., Salvadorean Club "Club of Salvadoren" Inc., Sandringham Community Playground Inc., School of Early Childhood Studies Student Association Inc., Segarsonics Basketball Club Inc., Sen Kai Ryu Martial Arts Inc., Sepp Social Club Inc., Shanghai Fraternity Association Inc., Shepparton Baseball Club Inc., Shepparton Rock and Roll Club Inc., Shepparton Warriors Rugby League Club Inc., Shire of Diamond Valley Works Depot Social Club Inc., Silver Glove Gymnastics Club Inc., Sir Charles Darling Hotel Pool and Social Club Inc., Skate Connection Inc., Soroptimist International of Carawah Inc., Sorrento Sports Club Inc., South Seas Strikers Sports & Social Club Inc., South West Tourism, Victoria Inc., South/Port Workers With Youth Network Inc., Southern European and Latin Gay Men Inc., Southern Region Aged Services Network Inc., Southern Speed Slalom Inc., St Elizabeth's Football Club Inc., St. Andrew's Three Year Old Groups Heathmont Inc., St. Arnaud Stadium Gymnasium Club Inc., St. Arnaud Youth & Community Support Group Inc., St. Fidelis Tennis Club Inc., St. Leonards College Old Collegians Football Club Inc., St. Leonards Young Peoples Group Inc., St. Paul's

McKinnon Junior Football Club Inc., Starting Five Enterprises Inc., Stawell Indoor Netball Association Inc., Strezelecki Women's Health Action Collective Inc., Studio 9 Photographers Association Inc., Sudan Relief & Rehabilitation Association of Australia Inc., Sunbury Aero Club Inc., Sunnyside Junior Football Club Inc., Sunraysia Development Corporation Inc., Surrey Cromwell Area Residents Group Inc., Swan Hill Super League Darts Inc., Sydenham Greening Group Inc., Talentshare International Association Inc., Tallarook Youth Group Inc., Tarlina Association Inc., Telegraph Hotel Sports & Recreation Club Inc., Thai Association of Victoria Inc., The "8" Ball Club of Melbourne Inc., The Benalla Motor Cycle Club Inc., The Biro Club Inc., The Central Victorian Arabian Racing and Action Club Inc., The Federation of Greek Communities of Melbourne & Victoria Inc., The First Years of School (Melbourne) Inc., The Free The Battery Hen Association Inc., The Goulburn Combined Group Inc., The Institute of Research on the Art of the Actor Inc., The Ken Blake Foundation Inc., The Mizrachi Fund Inc., The Mount Edgecombe Sports Club Inc., The Multi-Faith Resource Centre Inc., The North Eastern Handicapped Persons Association Inc., The North Richmond Family Resource Group Inc., The Park Playgroup Inc., The Post Secondary Disability Integration Network Inc., The Werribee Polocrosse Club Inc., The West Heidelberg Branch Blue Light Disco Inc., The Women's Gallery Inc., Ukrainian Professional and Business Association Inc., United Macedonians of Victoria Inc., Upper Yarra Ratepayers & Residents Association Inc., Victoria Hall Melton South Committee Inc., Victorian & Tasmanian Volkswagon-Audi Dealers Association Inc., Victorian Amateur Squashketball Inc., Victorian Association for Care of Yugoslav Elderly Inc., Victorian Association of Meat Purveyors Inc., Victorian Chinese Welfare Centre Inc., Victorian Federation De Lutte Amateur Inc., Victorian Land Protection Association Inc., Victorian Metropolitan Superules Football League Inc., Victorian Public Galleries Director's Association Inc., Victorian Racquetball Federation Inc., Victorian Scallop Industry Association Inc., Victorian Spiritual Association Inc., Vicworks Social Club Inc., Viet Studies Association Inc., Vietnamese Evangelical Church Springvale Inc., Vines Road Toy Library Inc., Wallan and

Districts Obedience Dog Club Inc., Warrnambool Tae Kwon Do Club Inc., Wendouree Skateboard Club Inc., West Canterbury Residents Group Inc., West Coburg Sports Club Inc., West Ivanhoe Football Club Inc., West Melbourne Action Group Inc., Western Region Blind Welfare Association Inc., Western Region Urban Environment Advisory Centre Inc., Westernport Disability Services Network Inc., Whittlesea District Health Council Inc., Wimbledon Heights Progress Association Inc., Windsor Calisthenic College Inc., Winslow Park Gymkhana Sub Committee Inc., Womens Professional Rodeo Association of Australia W.P.R.A. Inc., Woodend Jumping Joeys Inc., Woodville Softball Club Inc., Woori Yallock Community Group Inc., Yarra Valley Apex Club Inc., Young People In Need Inc., Young Peoples Health Service Inc., Youth Insearch Projects (Victoria) Inc., Zonta Club of Latrobe Valley.

Dated 16 October 2001

WAYNE NEW
Deputy Registrar
of Incorporated Associations

Associations Incorporation Act 1981

SUB-SECTION 36E(5)

Notice is hereby given that the incorporation of the associations mentioned below will be cancelled in accordance with Section 36E(5) of the **Associations Incorporation Act 1981**.

A.P.C. Club Inc., Accelerative Learning Society of Australia (Victoria) Inc., Afghan Australian Islamic & Cultural Association (Vic.) Inc., Alliance Mauricienne de Victoria Inc., Anderson-Wonthaggi State Mine Coastal Railway Association Inc., Anglesea Motorcycle Club Inc., Arboricultural Association of Australia Inc., Asbestos and Industrial Cancers Society Inc., Ashburton Alamein Youth Services Inc., Associazione Emilia Romagna Del Victoria Inc., Associazione Lombardi in Australia Inc., Assyrian-Australian Association Inc., Australia-Turkey Chamber of Commerce and Industry Inc., Australian-Turkish Welfare Federation Inc., Australian Appeal Association Inc., Australian Asian Community Welfare Association Inc., Australian Association of Zoological Marine Parks Inc., Australian Behaviour Modification Association (Victorian Branch) Inc., Australian Martial Arts Association

Inc., Australian Motorsport Club Inc., Avalon Speedway Sidecar Club Inc., B.C.I. Social Club Inc., Bairnsdale District Community Health Resource Group Inc., Ballarat Early Morning Health and Fitness Group Inc., Ballarat Rovers Basketball Club Inc., Batyo Catyo Ski Club Inc., Bend of Isles Residents Association Inc., Bendigo and District Cancer Support Group Inc., Bendigo Home Builders' Club Inc., Bendigo West Kindergarten Inc., Blackburn Players Inc., Boat Owners Association of Victoria Inc., Bonegilla Immigration Museum Inc., Box Hill Junior Football Club Inc., Bradmill Social and Sports Club Inc., Bright Sands Combined Life Saving Clubs Inc., Brighter Melbourne Committee Inc., Brolga Hotel Social Club Inc., Brunswick Broadmeadows Football Club Inc., Brunswick East High School Creche Association Inc., Campbells Creek Sports Ground Pavilion Committee Inc., Camperdown Jaycees Inc., Caritas Medical Centre Graduates Association Inc., Castlemaine and District Animal Aid Inc., Castlemaine Main Model Railroaders Inc., Central Highlands Repeater Association Inc., Chelsea Community Volunteer Service Inc., Church of Christ Fellowship Endeavour Hills Inc., Clifton Northern Socials Transwhelm Cricket Club Inc., Cobaw Emergency Accommodation Service Inc., Cockatoo Environment Group Inc., Community Contact Centre of South West Gippsland Inc., Concrete Pumping Association of Victoria Inc., Corio B.M.X. Club Inc., Croatian Community and Sporting Club Zagreb Inc., Croatia Women's Catholic Welfare Inc., Cyprus Chamber of Commerce and Industry in Australia Inc., Dalcroze Society of Victoria (Inc.), Daylesford Continuing Learning Inc., Dingo Research and Conservation Foundation Inc., Don Valley Three Year Old Kinder Inc., Eastland Squash Club Inc., Elsinor Gun Club Inc., Euroa Amateur Swimming Club Inc., Euroa Tourism and Development Committee Inc., Foster Care South East Inc., Fyans Creek Gun Club Inc., Geelong Amateur Cycling Club Inc., Geelong Men's Darts Association Inc., Gipp Swim Stars Inc., Gippsland Horse Activity Club Inc., Gippsland Youth Accommodation Services Inc., Gordon Community Children's Centre Association Inc., Goulburn Valley Amateur Volleyball Association Inc., Goulburn Valley Youth Choir Inc., Hanging Rock Athletics Club Inc., International Tae Kwon-Do Federation Black Belt Inc., International Village Steamship & Navigation Inc., Junktion Resource Centre Inc., Kananook Junior Association Inc., Kaniva Drama Group Inc., Killawarra Tennis Club Inc., Knowsley Tennis Club Inc., Kowree House Society Inc., Lakes Entrance Hockey Club Inc., Leongatha Calisthenics Club Inc., Lilydale Mooroolbark Marching Girls Club Inc., Limited Sprintcar Association of Victoria Inc., Longwarry and District Horse Riders Club Inc., Lowanna Youth Choir Inc., Macedon Football Club Inc., Marcus Hill Tennis Club Inc., Marong Municipal (Hopetoun) Band Inc., Mattel Australia Social Club Inc., Melbourne Show Jumping Club Inc., Melbourne Weightlifting Club Inc., Mentone Junior Football Club Inc., Meredith and District Pony Club Inc., Metropolitan Karting Consortium Inc., Metropolitan Midweek Football League Inc., Metung & District Community Youth Club Inc., Mornington Squash Club Inc., Morwell Saints Junior Football Club Inc., Mount Beauty and District Table Tennis Association Inc., Mt. Duneed Tennis Club Inc., Murray Valley Ski Club Inc., North East Aboriginal Community Services Committee Inc., North East Regional Migrant Child Care Centre Inc., Nunawading Roller Skating Club Inc., Nyah District Apex Club Inc., Nydia House – Sunraysia Women's Collective Inc., Operation Raleigh Incorporated, Orbost & District Tourist Association Inc., Outlook Squash Club Inc., Owner Builder Association of Victoria Inc., Paragon Club Inc., Parkdale Rugby League Football Club Inc., Peninsula 4WD Club Inc., Peninsula Youth for Christ Inc., Port Philip Affiliated Agricultural Societies Inc., Project Recreation (Victoria) Inc., Promair Flying Club Inc., Promote Ballarat Association Inc., Rambler Car Club of Australia Inc., Rosedale & District Volleyball Association Inc., Rubicon/Eildon S.E.C. Social Club Inc., S.E.C.V. E.M.E.S.R. Social Club Inc., Sale Jaycees Inc., Save Stane Brae Committee Inc., Sebastopol Youth Club Inc., Seymour Volleyball Inc., Shire of Rodney Ratepayers Association Inc., Shotokan Karate Association of Victoria Inc., Snowy River Pleasure Riders Association Inc., South African Cultural Association (Vic.) Inc., South Eastern Family Rock 'N' Roll Club of Victoria Inc., South West Gippsland Football League Inc., Southern Star Sports Club Inc., Spoleto Melbourne Foundation Inc., St. Francis Xavier Cricket Club Inc., St. Lukes, Vermont Anglican Kindergarten Inc., St. Peters Boys' Club Inc., Strathdale Angling Club Inc., Suez Canal

International Sporting Club Inc., Sunraysia and Riverland Committee on Salinity Inc., Sunshine Citizens Advice Bureau Inc., Surrey Park Nunawading Marching Club Inc., Swan Reach Indoor Bowling Club Inc., Swanpool Kindergarten Inc., Tenpin Bowling Association of Victoria Inc., The Australian Institute of Rebirthing Inc., The Australian Liliam Society Inc., The Australian Warmblood Sporthorse Association Inc., The Bag Show Inc., The Bairnsdale Arts Council Inc., The Basin Netball Club Inc., The Bruthen Badminton Club Inc., The Clematis & Districts YMCA Youth Services Inc., The Diamond Valley BMX Club Inc., The Geelong Watersports Association Inc., The Gisborne Angling Club Inc., The Lindenow South Tennis Club Inc., The Lions Club of Kew Inc., The Middle Park Community Workshop Inc., The National Association for Conductive Education Inc., The Norlane/Corio Tenants Association Inc., The Numurkah Judo Club Inc., The Pickle Theatre Company Inc., The Public Tenants Union of Victoria Inc., The Torquay Sailing Club Inc., The Victorian Prison Officers Welfare Group Inc., Thirteeners Inc., Trade Union Committee on Central America Inc., Traditional Medicine of China Society (Australia) Inc., Traralgon Light Harness Club Inc., Tullamarine Softball Club Inc., Turkish Community Development Association Inc., TV8 Social Club Inc., Type VW Club Inc., Victorian Gun Club Inc., Victorian Kiwifruit Growers' Association Inc., Victorian Old Agricultural Collegians Association Inc., Victorian Sport & Game Fishing Club Inc., Victorian Squash League Inc., Wallington Tennis Club Inc., Wangaratta Rodeo Association Inc., Weather Station Keilor C.Y.S.S. Inc., Werribee Gun Club Inc., West Gippsland Softball Association Inc., Western Welfare Services Inc., Wimmera Motor Sports Club Inc., World Pan-Macedonian Congress Inc., Y.C.W. Football Club Inc., Yandoit Water Supply Association Inc., Yarra Valley Quarter Horse Association Inc., Yarram & District Model Aircraft Club Inc., Yarrunga Tennis Club Inc., Yorta Yorta Tribal Land Compensation Council of Elders Inc., Youth Employment Development Office Inc.

Dated 10 October 2001

WAYNE NEW
Deputy Registrar
of Incorporated Associations

Conservation, Forest and Lands Act 1987

NOTICE OF MAKING OF LAND MANAGEMENT COOPERATIVE AGREEMENTS

Notice is given under Section 60 of the **Conservation, Forests and Lands Act 1987** that individual Land Management Co-operative Agreements have been entered into between the Secretary to the Department of Natural Resources and Environment and each of the landowners listed in the Schedule to this notice.

Copies of the agreement are available for public inspection for a period of 30 days from the date of this publication, between the hours of 9am and 4pm at offices of the Department of Natural Resources and Environment listed, or at the Melbourne office at NRE Private Forestry, 1st Floor 250 Victoria Parade, East Melbourne, 3002.

North West Regional Office – Bendigo: T. Barber, Curran Road, McKenzie Creek; L.R. & E.J. Wilson, Banyena Road, Rupanyup North. S. Erickson, Newbridge Road, Laanecoorie; I. Huxley, Kearneys Road, Newbury; C. Roe, Lagoon Road, North Blackwood.

South West Regional Office – Ballarat: W. D. & C Blackwell, 'Corea', Dunkeld; M & R Dowd, Western Highway, Ararat; T. Leeming, 'Parado', Coleraine; Mortat Pty. Ltd., 'Eurambeen', Streatham Road, via Beaufort; R. H. C. Seymour, 'Yat Nat', Balmoral. T. Bugeja, 'Jororieka', Ballarat-Colac Road, Corindhap.

Port Phillip Regional Office – Box Hill: Ballan Pastoral Company, Geelong Road, Ballan; Cedar Rose Nominees and Davedene Pty Ltd, Loch-Wonthaggi Road, Krowera; E. Penny, Darraweit Guim.

North East Regional Office – Benalla: S. Benedyka & N. Ward, Orchard Lane, Chiltern; M & M. C. Byrne, Circular Creek Road, Stanley; G & B Hamilton, "Brookvale", Cudgeewa North; B. Howman, Happy Valley Road, Rosewhite.

I. Fox, Maroondah Highway, Yarck; T. J. C & R. M. Lusink, Ayredale-Mansfield Road, Euroa; R. Richardson, Alexanders Road, Benalla; J. & J. Ryan, Dual Brook, Steens Road, Boho South; P. Waite, Landscape Road, Tallarook.

Gippsland Regional Office – Traralgon:
Lake Tyers Trust, Rules Road, Lake Tyers;
L. J. Weddell, Hardy's Road, Metung. G. Boadle,
Peters Road, Ellinbank; V. P. Cumming, Princes
Highway, Traralgon East; H. Stephenson,
Longford-Letts Beach Road, Dutson.

CHLOE MUNRO
Secretary to the Department of
Natural Resources and Environment

Dental Practice Act 1999

Dr John C. Zeffert, dental surgeon, of
5 Malonga Court, North Caulfield was found
guilty of unprofessional conduct of a serious
nature by the Dental Practice Board of Victoria
following an inquiry held on 18 July 2001.

The penalties imposed by the Panel were –

- (1) A fine of \$2000;
- (2) A reprimand;
- (3) The condition that Dr Zeffert be
counselled by an Officer or Officers of
the Transport Accident Commission,
approved by the Board, on his
professional and ethical responsibility in
the determination and preparation of
patient treatment plans;
- (4) Suspension of registration from 9.00 am
1 August 2001 until midnight 31 October
2001.

VINCENT C. AMERENA
PSM, RFD, MDSc, LDS (Vic),
FRACDS, FICD, FPFA.
Investigative Officer

Dental Practice Act 1999

The Dental Practice Board of Victoria on
4 September 2001 found Mr Neville Collins,
dental prosthetist, of 49 Albert Street,
Sebastapol, guilty of unprofessional conduct of a
serious nature in that he had fabricated partial
artificial dentures for his patients when he had
not satisfactorily completed the prescribed
course of training and his license had not been
appropriately endorsed.

The Board reprimanded Mr Collins and
imposed a fine of \$2,500 and suspended the
registration of Mr Collins for a period of
3 months. This suspension being stayed until
Monday 9 September 2002 on the condition that

there are no further proven breaches of the
Dental Practice Act 1999, by Mr Collins during
this time.

VINCENT C. AMERENA
PSM, RFD, MDSc, LDS (Vic),
FRACDS, FICD, FPFA.
Investigative Officer

Education Act 1958

NOTICE OF MAKING OF ORDER UNDER SECTION 13

An Order of the Minister for Education was
made on 9 October 2001 under sections 13(4)
and 13(11) of the **Education Act 1958**
amending the constituting Order of Crib Point
Primary School Council in respect of the
membership of the school council.

MARY DELAHUNTY
Minister for Education

Education Act 1958

NOTICE OF MAKING OF ORDERS UNDER SECTION 13

An Order of the Minister for Education was
made on 26 September 2001 under sections
13(4) and 13(11) of the **Education Act 1958**
amending the constituting Order of Frankston
East Primary School Council in respect of the
membership of the school council.

MARY DELAHUNTY
Minister for Education

Evidence Act 1958

MEDIATORS

I, Peter Harmsworth, Secretary to the
Department of Justice, under the power found in
section 21K of the **Evidence Act 1958**, declare
each of the persons listed below to be a mediator
with the Dispute Settlement Centre of Victoria:

Alan George Brown, Jeannette Leanne
Vaha'akolo, Bindi Jane James, Simon Holmes,
Paul Justin Stewart, Reginald James Thorpe,
David James Farrall, Delta Vidler, Charles
Andrew Williams, Lisa Briggs, Lorraine
Beeton, Sharelle Leona Bonanno, Cleo Dimer,
James Flanagan, Sharon Rickey, Katherine
Anne Douglas.

Dated 8 October 2001

PETER HARMSWORTH
Secretary to the
Department of Justice



Heritage
VICTORIA

Heritage Act 1995

NOTICE OF REGISTRATION

As Executive Director for the purpose of the Heritage Act, I give notice under section 46 that the Victorian Heritage Register is amended by including the Heritage Register Number 1949 in the category described as a Heritage place:

Ranger Barracks, Curtis Street, Ballarat, City of Ballarat.

EXTENT:

1. All of the building known as Ranger Barracks and marked B1 on Diagram held by the Executive Director.

2. All of the Land marked L1 and L2 on Diagram 1949 held by the Executive Director being part of the land described in Certificate of Title Volume 5758 Folio 484 and all of the Crown Allotment 10A, Section J3, Township of Ballarat East.

Dated 15 October 2001

RAY TONKIN
Executive Director

Land Acquisition and Compensation Act 1986

FORM 7 S.21
Reg.16

Notice of Acquisition

Compulsory Acquisition of Interest in Land

The Roads Corporation (VicRoads), declares that by this notice it acquires the following interest in the land described as part of Plan of Consolidation No 163853K, Parish of Nunawading, comprising 19 square metres and being land described in Certificate of Title Volume 9778, Folio 287 shown as Parcel 23 on Roads Corporation Survey Plan 19961.

Interest Acquired: That of Perpetual Nominees Limited and all other interests.

Published with the authority of VicRoads.

The Survey Plan referred to in this notice may be viewed without charge at the office of Property Services Department, VicRoads,

4th Floor, North Building, 60 Denmark Street, Kew during the hours 9.00 am to 4.00 p.m.

Dated 18 October 2001

For and on behalf of VicRoads:
A. O'BRIEN,
Acting Manager,
Property Services Department.

Land Acquisition and Compensation Act 1986

FORM 7 S.21
Reg.16

Notice of Acquisition

Compulsory Acquisition of Interest in Land

The Roads Corporation (VicRoads), declares that by this notice it acquires the following interest in the land described as part of Plan of Consolidation No 163459P, Parish of Nunawading, comprising 130 square metres and being land described in Certificate of Title Volume 9723, Folio 403, shown as Parcel 35 on Roads Corporation Survey Plan 19960A.

Interest Acquired: That of Navy Health Limited and all other interests.

Published with the authority of VicRoads.

The Survey plan referred to in this notice may be viewed without charge at the office of Property Services Department, VicRoads, 4th Floor, North Building, 60 Denmark Street, Kew during the hours 9.00 am to 4.00 p.m.

Dated 18 October 2001

For and on behalf of VicRoads:
A. O'BRIEN,
Acting Manager,
Property Services Department.

Land Acquisition and Compensation Act 1986

FORM 7 S.21
Reg.16

Notice of Acquisition

Compulsory Acquisition of Interest in Land

Roads Corporation (VicRoads) declares that by this notice it acquires the following interest in the land described as part of Lot 1 on Plan of Subdivision No. 80231, Parish of Nunawading, comprising 225 square metres, and being part of the land contained in Certificate of Title Volume 8714, Folio 123 and shown as Parcel 16 on VicRoads Survey Plan numbered 19960A.

Interest Acquired: That of Bredix Pty Ltd and all other interests.

Published with the authority of VicRoads.

The Survey plan referred to in this notice may be viewed at the office of Property Services Department, VicRoads, 60 Denmark Street, Kew. Dated 18 October 2001

For and on behalf of VicRoads:
A. O'BRIEN,
Acting Manager,
Property Services Department.

Land Acquisition and Compensation Act 1986

FORM 7 S.21
Reg.16

Notice of Acquisition

Compulsory Acquisition of Interest in Land

Roads Corporation (VicRoads) declares that by this notice it acquires the following interest in the land described as part of Lots 3, 4, 5 and 6 on Plan of Subdivision No 14490, Parish of Nunawading, comprising 247 square metres and being part of the land contained in Certificate of Title Volume 9565, Folio 358 and shown as Parcel 10 on VicRoads Survey Plan numbered 19959A.

Interest Acquired: That of Ronald George Lloyd and Roma Susan Lloyd and all other interests.

Published with the authority of VicRoads.

The Survey Plan referred to in this notice may be viewed at the office of Property Services Department, VicRoads, 60 Denmark Street, Kew. Dated 18 October 2001

For and on behalf of VicRoads:
A. O'BRIEN,
Acting Manager,
Property Services Department.

Land Acquisition and Compensation Act 1986

FORM 7 S.21
Reg.16

Notice of Acquisition

Compulsory Acquisition of Interest in Land

Roads Corporation (VicRoads) declares that by this notice it acquires the following interest in the land described as part of the land in Plan of Consolidation No. 163810E, Parish of Nunawading, comprising 498 square metres,

being part of the land contained in Certificate of Title Volume 9716, Folio 666 and shown as Parcel 28 on VicRoads Survey Plan numbered 19959A.

Interest Acquired: That of Mobil Oil Australia Limited and all other interests.

Published with the authority of VicRoads.

The Survey Plan referred to in this notice may be viewed at the office of Property Services Department, VicRoads, 60 Denmark Street, Kew. Dated 18 October 2001

For and on behalf of VicRoads:
A. O'BRIEN,
Acting Manager,
Property Services Department.

Land Acquisition and Compensation Act 1986

FORM 7 S.21
Reg.16

Notice of Acquisition

Compulsory Acquisition of Interest in Land

Roads Corporation (VicRoads) declares that by this notice it acquires the following interest in the land described as part of Lot 7 on Plan of Subdivision No 14490, comprising 126 square metres, being part of the land contained in Certificate of Title Volume 6856, Folio 157 and shown as Parcel 11 on VicRoads Survey Plan numbered 19959A.

Interest Acquired: That of The Estate of G. R. Manley and all other interests.

Published with the authority of VicRoads.

The Survey Plan referred to in this notice may be viewed at the office of Property Services Department, VicRoads, 60 Denmark Street, Kew.

Dated 18 October 2001

For and on behalf of VicRoads:
A. O'BRIEN,
Acting Manager,
Property Services Department.

Land Acquisition and Compensation Act 1986

FORM 7 S.21
Reg.16

Notice of Acquisition

Compulsory Acquisition of Interest in Land

Roads Corporation (VicRoads) declares that by this notice it acquires the following interest

in the land described as part of Lot 1 on Plan of Subdivision No. 30217, comprising 16 square metres and being part of the land contained in Certificate of Title Volume 8080, Folio 701 and shown as Parcel 29 on VicRoads Survey Plan numbered 19959A.

Interest Acquired: That of Ley-Choon Teo and all other interests.

Published with the authority of VicRoads.

The Survey Plan referred to in this notice may be viewed at the office of Property Services Department, VicRoads, 60 Denmark Street, Kew.

Dated 18 October 2001

For and on behalf of VicRoads:
A. O'BRIEN,
Acting Manager,
Property Services Department.

Land Acquisition and Compensation Act 1986

FORM 7 S.21
Reg.16

Notice of Acquisition

Compulsory Acquisition of Interest in Land

Roads Corporation (VicRoads) declares that by this notice it acquires the following interest in the land described as part of Elgar's Crown Special Survey, Parish of Nunawading, County of Bourke, comprising 15 square metres, and being part of the land contained in Certificate of Title Volume 7446, Folio 046 and shown as Parcel 26 on VicRoads Survey Plan numbered 19959A.

Interest Acquired: That of Arthur Leslie McPhee and all other interests.

Published with the authority of VicRoads.

The Survey Plan referred to in this notice may be viewed at the office of Property Services Department, VicRoads, 60 Denmark Street, Kew.

Dated 18 October 2001

For and on behalf of VicRoads:
A. O'BRIEN,
Acting Manager,
Property Services Department.

Land Acquisition and Compensation Act 1986

FORM 7 S.21
Reg.16

Notice of Acquisition

Compulsory Acquisition of Interest in Land

The Roads Corporation (VicRoads), declares that by this notice it acquires the following interest in the land described as part of Common Property on Strata Plan 25813P, Parish of Nunawading, comprising 45 square metres and being land described in Certificate of Title Volume 9734, Folio 471, Volume 9734, Folio 472, shown as Parcel 27 on Roads Corporation Survey Plan 19959A.

Interest Acquired: That of Body Corporate RP25813P and all other interests.

Published with the authority of VicRoads.

The Survey Plan referred to in this notice may be viewed without charge at the office of Property Services Department, VicRoads, 4th Floor, North Building, 60 Denmark Street, Kew during the hours 9.00 am to 4.00 p.m.

Dated 18 October 2001

For and on behalf of VicRoads:
A. O'BRIEN,
Acting Manager,
Property Services Department.

Land Acquisition and Compensation Act 1986

FORM 7 S.21
Reg.16

Notice of Acquisition

Compulsory Acquisition of Interest in Land

The Roads Corporation (VicRoads), declares that by this notice it acquires the following interest in the land described as part of Common property on Plan of Subdivision No PS418535E, Parish of Nunawading, comprising 159 square metres and being land described in Certificate of Title Volume 10562, Folio 601, shown as Parcel 34 on Roads Corporation Survey Plan 19960A.

Interest Acquired: That of Body Corporate of Plan No PS418535E and all other interests.

Published with the authority of VicRoads.

The Survey Plan referred to in this notice may be viewed without charge at the office of Property Services Department, VicRoads, 4th Floor, North Building, 60 Denmark Street, Kew during the hours 9.00 am to 4.00 p.m.

Dated 18 October 2001

For and on behalf of VicRoads:
A. O'BRIEN,
Acting Manager,
Property Services Department.

Land Acquisition and Compensation Act 1986

FORM 7 S.21
Reg.16

Notice of Acquisition

Compulsory Acquisition of Interest in Land

The Roads Corporation (VicRoads), declares that by this notice it acquires the following interest in the land described as part of Plan of Consolidation No 162129S, Parish of Nunawading, comprising 202 square metres and being land described in Certificate of Title Volume 9687, Folio 429, shown as Parcel 32 on Roads Corporation Survey Plan 19960A.

Interest Acquired: That of Pratt Corporation Pty Ltd and all other interests.

Published with the authority of VicRoads.

The Survey plan referred to in this notice may be viewed without charge at the office of Property Services Department, VicRoads, 4th Floor, North Building, 60 Denmark Street, Kew during the hours 9.00 am to 4.00 p.m.

Dated 18 October 2001

For and on behalf of VicRoads:
A. O'BRIEN,
Acting Manager,
Property Services Department.

Land Acquisition and Compensation Act 1986

FORM 7 S.21
Reg.16

Notice of Acquisition

Compulsory Acquisition of Interest in Land

The Roads Corporation (VicRoads), declares that by this notice it acquires the following interest in the land described as part of Plan of Consolidation No 167242U, Parish of Nunawading, comprising 232 square metres and being land described in Certificate of Title Volume 9827, Folio 260, shown as Parcel 31 on Roads Corporation Survey Plan 19959A.

Interest Acquired: That of Hanex Investments Limited and all other interests.

Published with the authority of VicRoads.

The Survey plan referred to in this notice may be viewed without charge at the office of Property Services Department, VicRoads,

4th Floor, North Building, 60 Denmark Street, Kew during the hours 9.00 am to 4.00 p.m.

Dated 18 October 2001

For and on behalf of VicRoads:
A. O'BRIEN,
Acting Manager,
Property Services Department.

Land Acquisition and Compensation Act 1986

FORM 7 S.21
Reg.16

Notice of Acquisition

Compulsory Acquisition of Interest in Land

The Roads Corporation (VicRoads), declares that by this notice it acquires the following interest in the land described as part of Plan of Consolidation No 160291T, Parish of Nunawading, comprising 155 square metres and being land described in Certificate of Title Volume 10324, Folio 890, shown as Parcel 36 on Roads Corporation Survey Plan 19960A.

Interest Acquired: That of 830 Whitehorse Road Pty Ltd and all other interests.

Published with the authority of VicRoads.

The Survey plan referred to in this notice may be viewed without charge at the office of Property Services Department, VicRoads, 4th Floor, North Building, 60 Denmark Street, Kew during the hours 9.00 am to 4.00 p.m.

Dated 18 October 2001

For and on behalf of VicRoads:
A. O'BRIEN,
Acting Manager,
Property Services Department.

Land Acquisition and Compensation Act 1986

FORM 7 S.21
Reg.16

Notice of Acquisition

Compulsory Acquisition of Interest in Land

The Roads Corporation (VicRoads), declares that by this notice it acquires the following interest in the land described as part of Elgars Crown Special Survey, Parish of Nunawading, comprising 413 square metres and being land described in Certificates of Title Volume 2864,

Folio 797 and Volume 6275, Folio 830, shown as Parcels 6 & 7 on Roads Corporation Survey Plan 19959A.

Interest Acquired: That of Ronald George Lloyd, Loris Ida Earl and Ward Motors Pty Ltd and all other interests

Published with the authority of VicRoads.

The Survey Plan referred to in this notice may be viewed without charge at the office of Property Services Department, VicRoads, 4th Floor, North Building, 60 Denmark Street, Kew during the hours 9.00 am to 4.00 p.m.

Dated 18 October 2001

For and on behalf of VicRoads:
A. O'BRIEN,
Acting Manager,
Property Services Department.

Land Acquisition and Compensation Act 1986

FORM 7 S.21
Reg.16

Notice of Acquisition

Compulsory Acquisition of Interest in Land

The Roads Corporation (VicRoads), declares that by this notice it acquires the following interest in the land described as part of Elgar's Crown Special Survey, Parish of Nunawading, comprising 130 square metres and being land described in Certificate of Title Volume 1935, Folio 917, shown as Parcel 4 on Roads Corporation Survey Plan 19959A.

Interest Acquired: That of Ward Properties Pty Ltd formerly Ward Motors Pty Ltd and Ward Motors Pty Ltd and all other interests.

Published with the authority of VicRoads.

The Survey Plan referred to in this notice may be viewed without charge at the office of Property Services Department, VicRoads, 4th Floor, North Building, 60 Denmark Street, Kew during the hours 9.00 am to 4.00 p.m.

Dated 18 October 2001

For and on behalf of VicRoads:
A. O'BRIEN,
Acting Manager,
Property Services Department.

Livestock Disease Control Act 1994

REVOCATION OF DECLARATION OF APPROVED AGENT

Notice is hereby given that on 25 September 2001 the Commissioner of State Revenue revoked pursuant to section 94(2) of the **Livestock Disease Control Act 1994** the declaration of the undermentioned person, being a person carrying on business as a stock and station agent, an abattoir operator, a feedlot operator, a cattle scale operator, a calf dealer or any other prescribed business dealing with the buying or selling of livestock or the carcasses of livestock, as approved agents for the purposes of part 6 of the **Livestock Disease Control Act 1994**, and of the **Stamps Act 1958**.

ICM Farm Products Australia Pty Ltd trading as Yarrowonga Abattoirs (CS260).

CHRISTOPHER CHARLES EDWIN GAHAN
as delegate of the Secretary
to the Department of
Natural Resources and Environment

Physiotherapists Registration Act 1998

PHYSIOTHERAPISTS REGISTRATION OF VICTORIA

Fees Payable to the Board

In accordance with Section 85(1)(c) of the **Physiotherapists Registration Act 1986** the Board has fixed the following fees which will be payable to the Board from 1 December 2001:

Fee	\$
General registration	150.00
General registration for a period of less than 3 months	50.00
Specific registration	150.00
Renewal of registration	95.00
Additional renewal fee	40.00
Restoration of registration	160.00
Copy of register	50.00
Copy of register on computer disk	40.00
Extract from register	25.00
Issue of Replacement Certificate	50.00

Dated 11 October 2001

M E STRICKLAND
Registrar

Road Safety Act 1986

ORDER UNDER SECTION 98
ROAD SAFETY ACT 1986 EXTENDING
 PROVISIONS TO THE MCDONALDS
 CARPARK (WELLS STREET),
 452 NEPEAN HIGHWAY, FRANKSTON

I, Bruce Gidley, Regional Manager, VicRoads Metro South East Region, delegate of the Minister for Transport under Section 98 of the **Road Safety Act 1986** by this Order extend the application of:

- (a) Sections 59, 64, 65, 76, 77, 85-90, 99 and 100 of that Act; and
- (b) The Road Safety (Road Rules) Regulations 1999; and
- (c) Parts 5 and 6 and Schedules 3 and 4 of the Road Safety (Procedures) Regulations 1999 to the McDonalds Carpark (Wells Street) at 452 Nepean Highway, Frankston within Frankston City Council, particulars of which are shown on the attached plan.

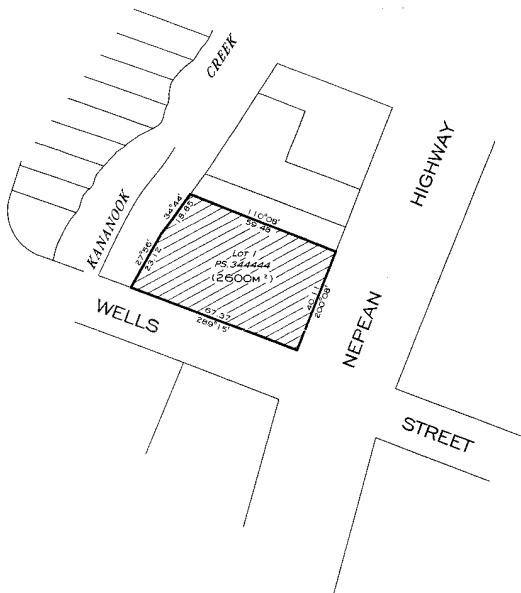

Dated 11 October 2001

BRUCE GIDLEY
 Regional Manager

Road Safety Act 1986

ORDER UNDER SECTION 98
ROAD SAFETY ACT 1986 EXTENDING
 PROVISIONS TO THE OLSEN STREET
 CARPARK, 9 ROSSMITH AVENUE,
 FRANKSTON

I, Bruce Gidley, Regional Manager, VicRoads Metro South East Region, delegate of the Minister for Transport under Section 98 of the **Road Safety Act 1986** by this Order extend the application of:

- (a) Sections 59, 64, 65, 76, 77, 85-90, 99 and 100 of that Act; and
- (b) The Road Safety (Road Rules) Regulations 1999; and
- (c) Parts 5 and 6 and Schedules 3 and 4 of the Road Safety (Procedures) Regulations 1999 to the Olsen Street Carpark at 9 Rossmith Avenue, Frankston within Frankston City Council, particulars of which are shown on the attached plan.

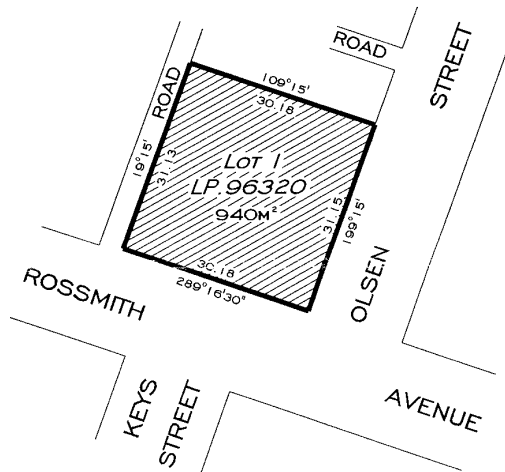

Dated 11 October 2001

BRUCE GIDLEY
 Regional Manager

Road Safety Act 1986

MOTORCYCLE TWO-DAY ENDURO

Under section 68 (3) of the **Road Safety Act 1986**, I declare that sub-sections (1) and (2) of section 68 of the Act shall not apply with respect to the event to be conducted by the Bairnsdale and District Motorcycle Club Inc. to be

conducted in the Bullumwaal State Forest on Saturday 20 and Sunday 21 October 2001, starting at 8.30 a.m. and concluding at 4.00 p.m. each day.

Dated 12 October 2001

PETER McCULLOCH
Regional Manager
VicRoads – Eastern Victoria
Delegate of the Minister for Transport

Transport Act 1983

TOW TRUCK DIRECTORATE OF
VICTORIA

Tow Truck Application

Notice is hereby given that the following application will be considered by the Licensing Authority after 21 November 2001.

Notice of any objection to the granting of the application should be forwarded to reach the Director, Tow Truck Directorate of Victoria, Level 6, 14–20 Blackwood Street, North Melbourne, (P.O. Box 666, North Melbourne 3051) not later than 15 November 2001.

It will not be necessary for interested parties to appear on the date specified, unless advised in writing.

F. D. Schottner. Application for variation of conditions of tow truck licence number TOW484 which authorises the licensed vehicle to be managed, controlled and operated from a depot situated at 32 Emily Street, Seymour to change the depot address to 13 Millenium Park, Whittlesea.

Note: This licence is under consideration for transfer to Just Lux Pty Ltd.

Dated 18 October 2001

STEVE STANKO
Director

Transport Act 1983

TOW TRUCK DIRECTORATE OF
VICTORIA

Tow Truck Application

Notice is hereby given that the following application will be considered by the Licensing Authority after 21 November 2001.

Notice of any objection to the granting of the application should be forwarded to reach the Director, Tow Truck Directorate of Victoria, Level 6, 14–20 Blackwood Street, North

Melbourne (PO Box 666, North Melbourne 3051) not later than 15 November 2001.

It will not be necessary for interested parties to appear on the date specified, unless advised in writing.

A. N. Rudd. Application for variation of conditions of tow truck licence numbers TOW463, TOW464 and TOW465 which authorises the licensed vehicles to be managed, controlled and operated from a depot situated at 1857 Ferntree Gully Road, Ferntree Gully to change the depot address to 2–4 Scoresby Road, Bayswater.

Note: This licence is under consideration for transfer to Bettar Towing Pty Ltd.

Dated 18 October 2001

STEVE STANKO
DIRECTOR

Witness Protection Act 1991

GOVERNMENT OF VICTORIA

I, André Haermeyer, Minister for Police and Emergency Services and Minister administering the **Witness Protection Act 1991**, acting under section 3 of the **Witness Protection Act 1991**, declare the **Witness Protection Act 2000** of the State of Tasmania, being a law that makes provision for the protection of witnesses, to be a complementary witness protection law for the purposes of the **Witness Protection Act 1991**.

Dated 4 October 2001

ANDRÉ HAERMMEYER
Minister for Police
and Emergency Services

Witness Protection Act 1991

GOVERNMENT OF VICTORIA

I, André Haermeyer, Minister for Police and Emergency Services and Minister administering the **Witness Protection Act 1991**, acting under section 3 of the **Witness Protection Act 1991**, declare the **Witness Protection Act 2000** of the State of Queensland, being a law that makes provision for the protection of witnesses, to be a complementary witness protection law for the purposes of the **Witness Protection Act 1991**.

Dated 4 October 2001

ANDRÉ HAERMMEYER
Minister for Police
and Emergency Services

**Water Act 1989**

**NOTICE OF INTENTION TO DECLARE PROPERTIES SERVICED WITH RESPECT
TO THE PROVISION OF WATER SUPPLY AND WASTEWATER SERVICES**

Water and/or wastewater pipes have been laid and are available to provide services to each property in the areas referred below. The Central Gippsland Region Water Authority, trading as "Gippsland Water", declares the properties to be serviced for the purpose of the **Water Act 1989**, from the date of Practical Completion Certificate and water and wastewater tariffs will be liable from that date.

WATER**SERVICED AREAS AS FOLLOWS:**

Traralgon:	Mapleson Drive, Lots 2 & 3 on PS 11238R	31/08/2000
Traralgon:	Ellavale Drive, Saxby and Adams Courts Lots 49 to 70 on PS 439062E	13/08/2001
Tyers:	Hinde Road, Volume 7295 Folio 820	24/07/2001
Trafalgar:	Williamsons Road, Lot 5 on LP 136913 & CA 17	02/07/2001
Willow Grove:	School Road, Part CP 156323	14/09/2001
Fulham:	Sale-Heyfield Road, Lots 1 and 2 on PS 446351G	05/06/2001
Glengarry:	Lower Cairnbrook Road CA 53	25/06/2001

WASTEWATER**SERVICED AREAS AS FOLLOWS:**

Traralgon:	Ellavale Drive, Saxby and Adams Courts Lots 49 to 70 on PS 439062E	13/08/2001
Yinnar:	Main Street, CA 57	21/08/2001
Glengarry:	Kyne Street, Lot 1 on PS 422479N	01/08/2001

JOHN MITCHELL
Chief Executive Officer

Casino Control Act 1991—section 60(1)
CASINO RULES NOTICE NO. 21 OF 2001

Rules of the Game—Blackjack

By this notice, the Victorian Casino and Gaming Authority **amends** the Rules in respect of the game "Blackjack"¹ as set out in the Schedule.

This notice operates with effect from 4.00am on 22 October 2001.

Dated 18 October 2001

BILL LAHEY
Director of Gaming and Betting
Director of Casino Surveillance

SCHEDULE

1. Amendments to rule 10.2.1

For rule 10.2.1, **substitute**—

- ‘10.2.1 If, at the time the Dealer is asking players to act on their hands, a player—
- 10.2.1.1 refuses or fails to act; or
- 10.2.1.2 is not present—
- a Game Supervisor or above may after a reasonable time has passed, at the request of the Dealer, direct the Dealer—
- 10.2.1.3 if the player’s hand has a soft total of 17 or more to regard the player as having elected to stand with the cards at that point total; or
- 10.2.1.4 if the player’s hand total has a soft total of less than 17, draw further cards to that hand until a soft total of 17 or more, or a hard total of 12 or more is reached; or
- 10.2.1.5 if the player’s hand has a hard total of 12 or more, to regard the player as having elected to stand with the cards at that point total; or
- 10.2.1.6 if the player’s hand total has a hard total of less than 12, draw further cards to that hand until a soft total of 17 or more, or a hard total of 12 or more is reached.’

2. Amendments to rule 15.9

For rule 15.9, **substitute**—

- ‘15.9 If a player is not given the option of drawing additional cards or the dealer fails to correctly act on a player’s decision an error has occurred and shall be settled in accordance with rule 15.2. Any cards dealt in the same round of play subsequent to an error occurring shall also be considered cards dealt in error.
- 15.9.1 An error that is not disclosed until after the commencement of a subsequent round of play will not have any effect on the outcome of subsequent rounds of play.’

1 The game of Blackjack and its rules were approved by notices published in the Victoria Government Gazette on 24 April 1997 (S44). The rules have subsequently been amended by—

- A notice dated 30 April 1998 (published in Victoria Government Gazette G17);
 - Casino Rules Notice No. 1 of 1999 published on 18 March 1999 (S39);
 - Casino Rules Notice No. 13 of 1999 published on 13 August 1999 (S121);
 - Casino Rules Notice No. 18 of 1999 published on 9 September 1999 (S136);
 - Casino Rules Notice No. 23 of 1999 published on 22 October 1999 (S156);
 - Casino Rules Notice No. 24 of 1999 published on 4 November 1999 (S161);
 - Casino Rules Notice No. 27 of 1999 published on 16 December 1999 (S183);
 - Casino Rules Notice No. 3 of 2000 published on 17 March 2000 (S32);
 - Casino Rules Notice No. 10 of 2000 published on 19 May 2000 (S68);
 - Casino Rules Notice No. 15 of 2000 published on 11 June 2000 (S103);
 - Casino Rules Notice No. 22 of 2000 published on 18 October 2000 (S147);
 - Casino Rules Notice No. 26 of 2000 published on 7 December 2000 (S184);
 - Casino Rules Notice No. 27 of 2000 published on 7 December 2000 (S184);
 - Casino Rules Notice No. 28 of 2000 published on 7 December 2000 (S184);
 - Casino Rules Notice No. 1 of 2001 published on 1 February 2001 (S9).
-

Residential Tenancies Act 1997

DECLARATION UNDER SECTION 19

1. The declaration under section 19 of the **Residential Tenancies Act 1997** ("the Act") made in the Victorian Government Gazette 24 June 1999 is hereby revoked.
2. The Director of Housing, as owner of the buildings listed in the schedule, has applied for a declaration under Section 19 of the Act that the buildings listed in the schedule are rooming houses for the purposes of this Act.
3. Under section 19 of the Act I declare each of the buildings listed in the schedule a rooming house for the purposes of the Act.

Dated 16 October 2001

HON BRONWYN PIKE MP

Minister for Housing & Aged Care

Director of Housing Properties for Rooming House Declaration

No.	Property Address	B'rm
6/36	Abbot Street, BENDIGO 3550	2
35	Acadia ST, MELTON 3337	3
22	Acheron CR, WERRIBEE 3030	3
1/17	Adelaide ST, FOOTSCRAY 3011	2
25	Adelaide ST, FOOTSCRAY 3011	2
47	Adelaide ST, FOOTSCRAY 3011	2
6/2	Adelaide ST, MURRUMBEENA 3163	2
2/20	Adelaide ST, ST ALBANS 3021	2
4	Agnes ST, BENTLEIGH EAST 3165	2
11	Airlie Bank RD, MORWELL 3840	3
1/8	Aitken ST, KANGEROO FLAT 3555	2
1/23	Alamein ST, NOBLE PARK 3174	2
1/25	Alamein ST, NOBLE PARK 3174	2
2/23	Alamein ST, NOBLE PARK 3174	2
2/25	Alamein ST, NOBLE PARK 3174	2
3/23	Alamein ST, NOBLE PARK 3174	2
3/25	Alamein ST, NOBLE PARK 3174	2
3/32	Alamein ST, NOBLE PARK 3174	2
6	Alawa PL, KEILOR DOWNS 3038	3
1/124	Albany DR, MULGRAVE 3170	3
2/66	Albert AV, BORONIA 3155	2
4	Albert AV, SPRINGVALE 3171	3
1/12	Albert AV, SPRINGVALE 3171	2
6	Albert ST, CAULFIELD NORTH 3161	3
3/117	Albert ST, FOOTSCRAY 3011	2
2/111	Albert ST, MORDIALLOC 3195	2
10	Alexandra AV, SALE 3850	3
6/6	Allamein RD, KILSYTH 3137	2

Director of Housing Properties for Rooming House Declaration

22	Allandale RD, MENTONE 3194	3
22	Allanfield CR, WANTIRNA 3152	3
58	Allendale RD, CROYDON 3136	3
1A	Allens RD, HEATHMONT 3135	2
20	Alleyne AV, BONBEACH 3196	3
2	Allison CT, BAIRNSDALE 3875	3
4	Aloha ST, SPOTSWOOD 3015	3
35	Amaroo DR, CHURCHILL 3842	3
47	Amaroo DR, CHURCHILL 3842	3
2	Amon CT, WOORI YALLOCK 3139	3
8	Amy Court, MILDURA 3500	2
2	Anderson ST, BENTLEIGH EAST 3165	3
5/74	Anderson ST, SUNSHINE 3020	2
2/3	Angela CT, WARRNAMBOOL 3280	2
1/27	Annesley Street, ECHUCA 3564	2
2/27	Annesley Street, ECHUCA 3564	2
6	Arbroath RD, STUFIELD 3152	3
4	Argus Court, EAGLEHAWK 3556	2
1/8	Argyle AV, CHELSEA 3196	2
2/8	Argyle ST, MOONEE PONDS 3039	2
1/37	Arlington ST, RINGWOOD 3134	2
8	Arnold Court, WOODEND 3442	3
31	Arnoldt Street, SWAN HILL 3585	3
2/12	Arnott Street, ROBINVALE 3549	2
9	Ascot ST, ASCOT VALE 3032	3
3/16	Ash GV, BAYSWATER 3153	2
10	Ashwood Court, MILDURA 3500	3
2/126	Athol RD, SPRINGVALE 3171	2
8	Auburn RD, HEALESVILLE 3777	3
1/4	Ausfeldi DVE, SPRING GULLY 3550	3
2/18	Austin RD, FERNTREE GULLY 3156	2
12	Badger Creek RD, HEALSVILLE 3777	3
1/76	Baggott DR, HOPPERS CROSSING 3029	2
1	Baker GV, WARRNAMBOOL 3280	3
1/17	Balaclava AV, ALTONA MEADOWS 3028	2
2/17	Balaclava AV, ALTONA MEADOWS 3028	2
1/72	Ballantine ST, BAIRNSDALE 3875	2
28/2	Ballarat RD, FOOTSCRAY 3011	2
2/31	Ballarat RD, FOOTSCRAY 3011	2
1/35	Balmoral RD, WARRNAMBOOL 3280	2

Director of Housing Properties for Rooming House Declaration

1/3	Bardsley ST, SUNSHINE 3020	2
2/41	Bardsley ST, SUNSHINE 3020	2
3/8	Baringhup ST, CHELTENHAM 3192	2
4/18-20	Baringhup ST, CHELTENHAM 3192	2
8/12	Baringhup ST, CHELTENHAM 3192	2
6/535	Barkly ST, FOOTSCRAY 3011	2
4/679	Barkly ST, FOOTSCRAY 3011	2
4	Barkly ST, PORTLAND 3305	2
20	Barnes CR, SUNSHINE 3020	3
2/32	Barries RD, MELTON 3337	2
2/34	Barries RD, MELTON 3337	2
9	Barrowby ST, PORTLAND 3305	3
87	Barry Street, ROMSEY 3434	3
78	Batesford RD, CHADSTONE 3148	2
1/12	Baynes ST, TERANG 3264	2
10/20	Bayview RD, FOOTSCRAY 3011	2
3/31	Bayview ST, ALTONA 3018	2
15	Beattie CR, MORWELL 3840	3
23	Beattie CR, MORWELL 3840	3
2/16	Beaufort RD, CROYDON 3136	2
2/23	Beaver ST, BOX HILL SOUTH 3128	3
1/37	Bedford RD, RINGWOOD 3134	2
37	Begonia ST, BOX HILL 3128	3
1/26	Bell ST, MOE 3825	2
2/26	Bell ST, MOE 3825	2
3/26	Bell ST, MOE 3825	2
43	Bellarine CT, MORWELL 3840	3
69	Bellevue AV, DONCASTER EAST 3109	3
13	Bent ST, FLEMINGTON 3031	2
4/7	Berkeley CR, ALTONA NORTH 3025	2
6/11/13	Bessemer ST, SPRINGVALE 3171	2
2/3	Biggs ST, ST ALBANS 3021	2
42	Birdwood ST, FOOTSCRAY 3011	2
5/232-234	Blackburn RD, DONCASTER EAST 3109	2
1/92	Blackburn RD, MOUNT WAVERLEY 3149	2
113	Blackburn RD, MOUNT WAVERLEY 3149	3
2/97	Blackshaws RD, SPOTSWOOD 3015	2
25	Blanche DR, VERMONT 3133	3
1/57	Blantyre AV, CHELSEA 3196	2
32	Bodkin Street, KYNETON 3444	3

Director of Housing Properties for Rooming House Declaration

6/135	Booran RD, CAULFIELD 3162	3
52	Brandon Park DR, MULGRAVE 3170	3
122	Brassey Street, MARYBOROUGH 3465	3
1/12	Bree ST, MELTON 3337	2
3	Brentwood ST, MOORABBIN 3189	3
5/10	Brentwood ST, MOORABBIN 3189	2
67A	Breton ST, WARRNAMBOOL 3280	2
21	Brett DR, KEYSBOROUGH 3173	3
1/96	Brewer RD, BENTLEIGH 3204	2
1/59	Brickwood ST, ELSTERNWICK 3185	3
14	Bridgewater DR, MORWELL 3840	2
1	Brighton RD, ELSTERNWICK 3185	2
6/4	Bronte CT, WILLIAMSTOWN 3016	2
1/10	Brosa AV, BENTLEIGH EAST 3165	2
1/10	Bubb ST, MOE 3825	2
6/47	Buckley ST, ESSENDON 3040	2
3/227	Buckley ST, ESSENDON 3040	2
1/7	Buckley Street, BENDIGO 3550	3
2/7	Buckley Street, BENDIGO 3550	2
3/19	Buckley Street, BENDIGO 3550	2
16	Buna ST, MORWELL 3840	2
2	Buna ST, MORWELL 3840	2
2/45	Bunney RD, CLARINDA 3169	3
20	Burnett AV, BRAYBROOK 3019	3
27	Burnside Street, EAGLEHAWK 3556	3
3/9	Cairo ST, BOX HILL NORTH 3129	2
2/6	Callaghan ST, NOBLE PARK 3174	3
2	Callander CR, HOPPERS CROSSING 3029	3
36A	Cambra RD, BELMONT 3216	2
15	Cambrian WAY, MELTON 3337	3
27	Camp ST, OMEO 3898	3
8	Campaspe CR, KEILOR 3036	3
2/13	Campbell ST, RINGWOOD 3134	2
1/435	Campbell Street, SWAN HILL 3585	2
1	Canning Close, MILDURA 3500	3
2/79	Canning ST, AVONDALE HEIGHTS 3034	2
1/58	Canterbury RD, BLACKBURN SOUTH 3130	2
4/12	Carlton ST, MCKINNON 3204	2
3/9	Carmichael ST, FOOTSCRAY 3011	2
1/33	Carpenter ST, LAKES ENTRANCE 3909	2

Director of Housing Properties for Rooming House Declaration

2/67	Carpenter Street, BENDIGO 3550	2
6	Cartledge WAY, SALE 3850	3
4/71	Cary ST, SUNSHINE 3020	2
3/29	Casey Street, BENDIGO 3550	2
1/38	Cathcart ST, MAIDSTONE 3012	2
22A	Cavallo Drive, MILDURA 3500	2
1/34-36	Cavehill RD, LILYDALE 3140	2
2/59	Cavehill RD, LILYDALE 3140	3
213	Centenary AV, MELTON 3337	3
9	Centennial ST, WEST FOOTSCRAY 3012	3
790	Centre RD, BENTLEIGH 3204	3
1/646-648	Centre RD, BENTLEIGH EAST 3165	2
782	Centre RD, BENTLEIGH EAST 3165	3
890	Centre RD, OAKLEIGH SOUTH 3167	3
3/75	Chaffey Avenue, MILDURA 3500	2
29	Chapple Street, EAGLEHAWK 3556	2
1/26	Charles ST, CHELTENHAM 3192	3
12	Charles ST, MOE 3825	3
1/39	Charlotte ST, NEWPORT 3015	2
2/39	Charlotte ST, NEWPORT 3015	2
2/138	Charman RD, MENTONE 3194	2
1/2B	Charnfield CR, NOBLE PARK 3174	2
2/2B	Charnfield CR, NOBLE PARK 3174	2
333	Cheltenham RD, KEYSBOROUGH 3173	3
1/69	Chesterville RD, CHELTENHAM 3192	2
1/22	Church ST, LAKES ENTRANCE 3909	2
84	Church Street, KANGAROO FLAT 3555	3
10/14	Churchill AVE, ASCOTVALE 3032	2
15/61	Churchill AVE, ASCOTVALE 3032	2
2	Citrinus Court, ROMSEY 3434	3
2/270	Civic PDE, ALTONA 3018	2
17	Clapperton AV, BENTLEIGH 3204	3
1/44	Clarendon ST, HAMILTON	2
5/7A	Clarke ST, WEST FOOTSCRAY 3012	2
1/456	Clayton RD, CLAYTON SOUTH 3169	3
3	Cleary Avenue, MILDURA 3500	3
3	Cleary ST, SPRINGVALE 3171	3
1/7	Cobham ST, MITCHAM 3132	3
8	Combay ST, BAIRNSDALE 3875	3
2/72	Condon Street, KENNINGTON 3550	2

Director of Housing Properties for Rooming House Declaration

2/1	Cooke AV, MOORABBIN 3189	2
1	Coolaroo PL, CHURCHILL 3842	3
3/31	Coorigal ST, CARNEGIE 3163	2
1/30	Cootamundra CR, BLACKBURN 3130	2
2/118	Cornwall RD, SUNSHINE 3020	3
1/66	Corrigan RD, NOBLE PARK 3174	3
2/66	Corrigan RD, NOBLE PARK 3174	3
12	Coulter AV, HAMILTON 3300	3
1/27	Courtney AVE, HOPPERS CROSSING 3012	2
18	Cresdale RD, WANTIRNA 3152	3
17	Crestway , LILYDALE 3140	3
2/44	Cribbes RD, WANGARATTA 3677	2
128	Crook Street, BENDIGO 3550	3
1/1	Crowley RD, HEALESVILLE 3777	2
23	Crown ST, FLEMINGTON 3031	2
25	Crown ST, FLEMINGTON 3031	2
27	Crown ST, FLEMINGTON 3031	2
59	Crown ST, FLEMINGTON 3031	2
3/2	Cumberland AV, NOBLE PARK 3174	2
3	Dale CL, TRARALGON 3844	3
6/12	Dalny RD, MURRUMBEENA 3163	2
2/11	Dalyston ST, GROVEDALE 3216	2
3/1-5	D'Arcy St, DONCASTER	2
1/6-10	D'Arcy St, DONCASTER	2
10	Dart ST, HIGHETT 3190	3
3	David DRV MOOROOLBARK 3138	3
68	David ST, HAMPTON 3188	3
95	Day ST, BAIRNSDALE 3875	3
2	Day Street, BENDIGO 3550	2
1/300	Deakin Avenue, MILDURA 3500	2
90	Deakin ST, ESSENDON 3040	3
15	Dean ST, BELMONT 3216	2
1/1-3	Derson ST, St ALBANS 3021	3
2/1-3	Derson ST, St ALBANS 3022	3
3/1-3	Derson ST, St ALBANS 3023	3
4/1-3	Derson ST, St ALBANS 3024	3
1/6	Desmond Street, BENDIGO 3550	2
2/6	Desmond Street, BENDIGO 3550	2
2A	Devonport CRT, ALTONA MEADOWS 3028	2
3/2	Dick Street, CASTLEMAINE 3450	2

Director of Housing Properties for Rooming House Declaration

1/37	Doncaster East RD, MITCHAM 3132	3
4/930	Doncaster RD, DONCASTER 3108	2
2/1068	Doncaster RD, DONCASTER 3108	3
1/1039	Doncaster RD, DONCASTER EAST 3109	3
2/1039	Doncaster RD, DONCASTER EAST 3109	3
41	Donnington Street, SWAN HILL 3585	3
1/230	Dorset RD, CROYDON 3136	2
1/371	Dorset RD, CROYDON 3136	3
1/422	Dorset RD, CROYDON 3136	3
2/422	Dorset RD, CROYDON 3136	3
13	Dowding CRT, FAWKNER 3060	2
7	Druitt ST, OAKLEIGH SOUTH 3167	3
4/12-14	Drummartin ST, SUNSHINE 3020	2
5	Dryden CON, MOOROOLBARK 3138	3
12	Dugan ST, SALE 3850	3
1/8	Dulcie GV, MOORABBIN 3189	2
1/9	Dunlop AV, ORMOND 3204	3
28	Dunstone Street, SWAN HILL 3585	3
5/4	Dwyer CT, MORWELL 3840	2
202	Eaglehawk RD, BENDIGO 3550	3
1/77	Eaglesham Street, MILDURA 3500	2
1/12	Eastern Beach RD, LAKES ENTRANCE 3909	2
2/12	Eastern Beach RD, LAKES ENTRANCE 3909	2
2/46	Edgar ST, WEST FOOTSCRAY 3012	2
5/45-47	Edgar ST, WEST FOOTSCRAY 3012	2
4/50	Edgar ST, WEST FOOTSCRAY 3012	2
2/80	Edina RD, FERNTREE GULLY 3156	2
1/267	Eighth Street, MILDURA 3500	2
2/9	Eldon CT, MOORABBIN 3189	2
10/12	Eldridge ST, FOOTSCRAY 3011	2
10/5	Eldridge ST, FOOTSCRAY 3011	2
381	Eleventh Street, MILDURA 3500	2
42	Eleventh Street, MILDURA 3500	3
115	Elgin ST, MORWELL 3840	3
1/32	Elizabeth ST, BENTLEIGH EAST 3165	3
8/35	Elizabeth ST, NEWPORT 3015	2
5/15	Elphingstone ST, FOOTSCRAY 3011	2
4/32	Emma ST, CAULFIELD 3162	2
37	Energetic Street, BENDIGO 3550	3
1/123	Epsom RD, ASCOT VALE 3032	2

Director of Housing Properties for Rooming House Declaration

3/123	Epsom RD, ASCOT VALE 3032	2
25	Etherington Drive, MILDURA 3500	3
1/4	Etherington Street, MILDURA 3500	2
2/4	Etherington Street, MILDURA 3500	3
33	Eumerella RD, CAULFIELD SOUTH 3162	3
11	Everard ST, WEST FOOTSCRAY 3012	3
32	Ewing Court, BENDIGO 3550	2
1/5	Farrington ST, BENDIGO 3550	2
2/5	Farrington ST, BENDIGO 3550	2
1/43	Faulkner ST, FOREST HILL 3131	3
2/8	Felix GV, MOOROOLBARK 3138	2
2/432	Ferntree Gully RD, GLEN WAVERLEY 3150	2
4/9	Filbert ST, BENTLEIGH EAST 3165	2
6	Findon CT, HIGHETT 3190	3
14	Finlayson CR, TRARALGON 3844	2
2/47	Finsbury ST, FLEMINGTON 3031	2
1/8	Fintonia ST, MURRUMBEENA 3163	3
2/8	Fintonia ST, MURRUMBEENA 3163	3
38	Gill AVE, EAGLEHAWK 3556	3
25	Gillie CR, MORWELL 3840	3
80	Gillies Street, MARYBOROUGH 3465	3
10/14	Gilmour ST, TRARALGON 3844	2
10	Gladstone ST, MOE 3825	3
4	Glenda CT, BAIRNSDALE 3875	2
447	Glenfern RD, UPWEY 3158	3
8/1015	Glenhuntly RD, CAULFIELD SOUTH 3162	2
4/1271	Glenhuntly RD, GLENHUNTLY 3163	2
2	Glover ST, SALE 3850	2
37	Golf RD, COBURG 3058	2
1/22	Golflinks AV, OAKLEIGH 3166	2
3	Goorawin PL, CHURCHILL 3842	3
12	Goulburn CT, ST ALBANS 3021	3
1/23	Governor RD, MORDIALLOC 3195	2
21	Grandview RD, LAKES ENTRANCE 3909	3
5/127	Grange RD, GLENHUNTLY 3163	2
14/160	Grange RD, GLENHUNTLY 3163	2
10/194	Grange RD, GLENHUNTLY 3163	2
1/257	Grange RD, ORMOND 3204	2
1/279	Grange RD, ORMOND 3204	2
2/11	Grant ST, ST ALBANS 3021	2
91	Gray Street, SWAN HILL 3585	3

Director of Housing Properties for Rooming House Declaration

2/1	Great Ryrie RD, RINGWOOD 3134	2
1/156	Greaves ST, WERRIBEE 3030	2
7	Greene Street, MACEDON 3440	3
1/169	Grey ST, TRARALGON 3844	2
2A	Grieve ST, BAYSWATER 3153	3
1/1	Gunsynd ST, KEILOR DOWNS 3038	3
37	Gunyah RD, BLACKBURN 3130	2
292	Guthridge PDE, SALE 3850	3
2A	Haines ST, MITCHAM 3132	2
20/49	Haines ST, NORTH MELBOURNE 3051	2
20	Hamel ST, BOX HILL SOUTH 3128	2
23/16-18	Hamilton RD, BAYSWATER 3153	2
1/14	Hamilton ST, ORBOST 3888	2
12	Hampstead CR, GLEN WAVERLEY 3150	3
33	Hampton PDE, WEST FOOTSCRAY 3012	3
1	Hannah ST, CHELTENHAM 3192	3
45	Hansen DR, GROVEDALE 3216	2
84	Hardiman ST, FLEMINGTON 3031	2
2/11	Harold ST, BONBEACH 3196	3
35	Harpur RD, CORIO 3214	2
1/9	Harrison CRT, ALTONA MEADOWS 3028	2
5/10	Hartley AV, FOOTSCRAY 3011	2
12	Hawthorn CRT, KERANG 3579	3
1/106	Hearn ST, COLAC 3250	2
10	Heath CR, MOORABBIN 3189	2
8	Heath CR, MOORABBIN 3189	3
2/1	Heather GV, CHELTENHAM 3192	2
4/108	Helms RD, NEWCOMB 3219	2
1/29	Henrietta ST, MOORABBIN 3189	2
16	Henry ST, WARRNAMBOOL 3280	2
20	Hercules Street, BENDIGO 3550	3
2/37	Hereford RD, MOUNT EVELYN 3796	3
2/53A	Hertford RD, SUNSHINE 3020	2
5/1	Hick ST, SPOTSWOOD 3015	2
20	High ST, BAIRNSDALE 3875	3
1/290	High ST, BELMONT 3216	2
432	High ST, MELTON 3337	3
1/89	High ST, NEWPORT 3015	2
2/89	High ST, NEWPORT 3015	2
567	High Street RD, MOUNT WAVERLEY 3149	3

Director of Housing Properties for Rooming House Declaration

77	High Street, SWAN HILL 3585	3
2/584	Highbury RD, GLEN WAVERLEY 3150	2
2/10	Hilda ST, CHELTENHAM 3192	3
1/8	Hill ST, BOX HILL SOUTH 3128	2
13	Hoddinott ST, BAIRNSDALE 3875	3
7/35	Holland CT, FLEMINGTON 3031	3
3/42	Holland CT, FLEMINGTON 3031	3
7/52	Holland CT, FLEMINGTON 3031	3
6/58	Holland CT, FLEMINGTON 3031	3
7/70	Holland CT, FLEMINGTON 3031	3
6/21	Holloway ST, CARNEGIE 3163	3
6/17	Holloway ST, ORMOND 3204	3
7	Holmby RD, CHELTENHAM 3192	3
72	Hook ST, ALTONA MEADOWS 3028	3
33	Hosken ST, SPRINGVALE SOUTH 3172	3
1/112	Hotham RD, NIDDRIE 3042	3
63	Hourigan RD, MORWELL 3840	3
1/74	Hourigan RD, MORWELL 3840	2
10/11-17	Howitt AV, CORIO 3214	2
13/8	Hudson ST, CAULFIELD 3162	2
2A	Huntley ST, MOONEE PONDS 3039	2
10	Hutson Street, KYABRAM 3620	3
30	Hyland CR, YARRAM 3971	2
2/72	Illawarra RD, FLEMINGTON 3031	2
12	Illawonga CT, CHURCHILL 3842	3
1/35	Illoura AV, RINGWOOD EAST 3135	3
4	Ina Close, MILDURA 3500	3
4/674	Inkerman RD, CAULFIELD NORTH 3161	2
2/3C	Innellan RD, MURRUMBEENA 3163	2
2/25	Iris CR, BORONIA 3155	2
1/8	Jackson ST, CROYDON 3136	2
2/33	Jackson ST, CROYDON 3136	2
11	Jacobs Avenue, KYNETON 3444	3
1/1	James AV, MITCHAM 3132	2
18	James CR, HAMPTON 3188	3
20	James CR, HAMPTON 3188	2
7/111	James ST, TEMPLESTOWE 3106	2
4/94	Jamieson ST, ST ALBANS 3021	2
8	Jason Street, BENDIGO 3550	3
2/46	Jasper RD, MOORABBIN 3189	2

Director of Housing Properties for Rooming House Declaration

3/37	Jean ST, CHELTENHAM 3192	2
3	Jennings ST, BAIRNSDALE 3875	2
10	Joanne PL, ST ALBANS 3021	3
10	Johnstone CR, COLAC 3250	2
2/11	Joy PDE, NOBLE PARK 3174	2
2/33	June ST, HIGHETT 3190	2
5/125	Kambrook RD, CAULFIELD SOUTH 3162	2
152	Kambrook RD, CAULFIELD SOUTH 3162	3
1/20	Karana DR, WARRNAMBOOL 3280	2
2/20	Karana DR, WARRNAMBOOL 3280	2
4/8	Kennedy ST, GLENROY 3046	2
16	Kensington RD, KENSINGTON 3031	2
1/44	Kent ST, MOE 3825	2
2/44	Kent ST, MOE 3825	3
1/62	Kerford ST, ESSENDON NORTH 3041	2
1/7	Kestrel PL, WERRIBEE 3030	2
2/7	Kestrel PL, WERRIBEE 3030	2
6/20	Kidgell ST, LILYDALE 3140	2
3/45	King PDE, KNOXFIELD 3180	3
17/18	King ST, ELSTERNWICK 3185	2
38	King ST, MOE 3825	3
10	Kinkora ST, MELTON 3337	3
61	Kooringal RD, UPWEY 3158	3
4/35	Kooyong RD, CAULFIELD NORTH 3161	3
4/4	Lachlan RD, SUNSHINE 3020	2
2/19	Laird ST, CROYDON 3136	3
1/19	Latham ST, BENTLEIGH EAST 3165	2
1/33	Latrobe ST, FOOTSCRAY 3011	3
2	Lauer ST, DONCASTER 3108	3
51	Laverock RD, WARRNAMBOOL 3280	3
1/7	Lawford ST, DONCASTER 3108	2
2/248	Lawrence RD, GLEN WAVERLEY 3150	2
2/12	Lawson ST, BLACKBURN 3130	3
3/20	Lawson ST, ESSENDON 3040	2
15	Lawson ST, HAMPTON 3188	3
19	Leander ST, FOOTSCRAY 3011	3
2	Leatherwood DR, MULGRAVE 3170	3
1A	Leawarra DR, HEATHMONT 3135	2
11/13	Leber ST, WARRANDYTE 3113	3
8/160	Lee ST, CARLTON 3053	2

Director of Housing Properties for Rooming House Declaration

237	Leichart ST, ECHUCA 3564	3
2/24	Leonard ST, RINGWOOD 3134	2
30	Leslie ST, SALE 3850	2
5	Lewis CT, SUNSHINE 3020	3
2/9	Lewis GV, MOUNT WAVERLEY 3149	2
9/94	Liddiard ST, HAWTHORN	2
Lot 2	Liepoldt Rise, GOLDEN SQUARE 3555	3
2/6A	Lilac CR, BRIGHTON 3186	2
66	Lilac Street, GOLDEN SQUARE 3555	2
2/1	Lindwall ST, GLEN WAVERLEY 3150	2
6/2	Liscard ST, ELSTERNWICK 3185	2
4	Llewellyn Court, EAGLEHAWK 3556	3
1/151	Lloyd ST, MOE 3825	2
201	Lloyd ST, STRATHDALE 3550	3
43	Lloyd Street, BENDIGO 3550	2
1/1	Lock ST, AIRPORT WEST 3042	2
2A	Lois ST, ST ALBANS EAST 3021	3
1/10	London RD, WODONGA 3690	3
2/10	London RD, WODONGA 3690	2
3/10	London RD, WODONGA 3690	2
4/10	London RD, WODONGA 3690	2
3/9	Longmore ST, CAMPERDOWN 3260	3
1A	Lorne ST, MOONEE PONDS 3039	2
3/102	Lower Dandenong RD, PARKDALE 3195	2
5	Luxford ST, ST ALBANS EAST 3021	3
2/7	Macdougall CR, TRARALGON 3844	2
1/3	Mackay AV, GLENHUNTLY 3163	2
5/62	Macpherson ST, FOOTSCRAY 3011	2
7/34	Madden AV, GLENHUNTLY 3163	2
2/62	Maidstone ST, RINGWOOD 3134	3
4/37	Maidstone ST, RINGWOOD 3134	2
1/97	Makepeace Street, SWAN HILL 3585	2
2/97	Makepeace Street, SWAN HILL 3585	2
2/5	Malinda CR, NORTH GEELONG 3215	2
May-27	Malvern AV, CAULFIELD NORTH 3161	3
5	Manna Gum CT, CHELSEA 3196	3
40	Margaret ST, MOE 3825	2
7/209	Maribyrnong RD, ASCOT VALE 3032	2
1/41	Marion ST, ALTONA EAST 3025	2
2/96	Marley ST, SALE 3850	2

Director of Housing Properties for Rooming House Declaration

12/90	Maroondah HWY, HEALESVILLE 3777	2
34A	Maroondah HWY, HEALESVILLE 3777	3
551	Maroondah HWY, RINGWOOD 3134	3
1	Marshall RD, BOX HILL NORTH 3129	3
3/13	Mason ST, FERNTREE GULLY 3156	3
3/15	Masters ST, CAULFIELD 3162	2
16	Mathers AV, LAUNCHING PLACE 3139	3
34	Matthew Flinders Drive, MILDURA 3500	3
4/25	Maureen CR, NOBLE PARK 3174	2
1A	McCole ST, SALE 3850	2
3/2	McComb ST, LILYDALE 3140	2
1/112	Mccurdy RD, HERNE HILL 3218	2
6	McDonald CR, TRARALGON 3844	3
30	McGreors RD, WARRNAMBOOL 3280	3
6	McNicol RD, TECOMA 3160	3
4/81	Melbourne RD, WILLIAMSTOWN 3016	2
1/17	Merlin CRES, CORIO 3214	2
49	Merrivale DR, WARRNAMBOOL 3280	2
4/23	Middle RD, MARIBYRNONG 3032	2
1/40	Middle RD, MARIBYRNONG 3032	2
35	Milbanke ST, PORTLAND 3305	3
9	Miller ST, EAGLEHAWK 3556	2
1/37	Milton AV, CLAYTON SOUTH 3169	2
10	Mirambeek RD, HOPPERS CROSSING 3029	3
3/14	Mitchell ST, BAIRNSDALE 3875	2
2/87-89	Mitchell ST, BENTLEIGH 3204	2
8	Mollison Street, KYNETON 3444	3
2/8	Moncoe ST, BORONIA 3155	3
2/14	Montgomery ST, RINGWOOD 3134	3
10	Moon CT, BAIRNSDALE 3875	3
2	Moore CRT, WERRIBEE 3030	3
3/27	Morang RD, HAWTHORN	2
112	Morris RD, UPWEY 3158	3
254	Morris RD, WERRIBEE 3030	3
109	Morris ST, SUNSHINE 3020	3
1/45	Mount Pleasant RD, NUNAWADING 3131	2
3/715	Mt Alexander RD, MOONEE PONDS 3039	2
1/102	Mt Dandenong RD, RINGWOOD 3134	2
3	Mt Riddells RD HEALSVILLE 3777	3
2/89	Muir ST, MOUNT WAVERLEY 3149	2

Director of Housing Properties for Rooming House Declaration

2/20	Mulgrave ST, ELSTERNWICK 3185	2
32	Mulkarra DR, CHELSEA 3196	3
52	Murdock Street, EAGLEHAWK 3556	3
8/33	Murray Street, KERANG 3579	2
4/119	Murrumbeena RD, MURRUMBEENA 3163	2
3/245	Murrumbeena RD, MURRUMBEENA 3163	2
1/1	Muscat Court, MILDURA 3500	2
4/6	Myers CT, NOBLE PARK 3174	3
10	Myrtle ST, WERRIBEE 3030	3
61	Nance ST, NOBLE PARK 3174	3
12/139	Napier ST, ESSENDON 3040	2
1/346	Napier Street, BENDIGO 3550	2
1/2	Nardu CT, SCORESBY 3179	3
1	Narini Court, CALIFORNIA GULLY 3556	2
1/264-266	Neerim RD, CARNEGIE 3163	2
4/6-8	Nelson ST, RINGWOOD 3134	2
5/14	Nelson ST, RINGWOOD 3134	2
1/16	Nelson Street, CALIFORNIA GULLY 3556	2
2/16	Nelson Street, CALIFORNIA GULLY 3556	2
3/16	Nelson Street, CALIFORNIA GULLY 3556	2
1/1173	Nepean HWY, HIGHETT 3190	2
2/1197	Nepean HWY, HIGHETT 3190	2
1/1	Nette CT, MOORABBIN 3189	3
2/1	Nette CT, MOORABBIN 3189	2
3/1	Nette CT, MOORABBIN 3189	2
4/1	Nette CT, MOORABBIN 3189	2
5/1	Nette CT, MOORABBIN 3189	2
6/1	Nette CT, MOORABBIN 3189	3
7/1	Nette CT, MOORABBIN 3189	2
1/12	Newmans RD, TEMPLESTOWE 3106	3
8/38	Newstead ST, MARIBYRNONG 3032	2
1/21	Nicholas GV, HEATHERTON 3202	3
1/210	Nicholson ST, BAIRNSDALE 3875	2
1/289	Nicholson ST, CARLTON 3053	2
5	Noonga PL, MORWELL 3840	3
3/24	Norfolk Street, BENDIGO 3550	2
38	Norma ST, MELTON 3337	3
620	North RD, ORMOND 3204	2
1/26	North ST, ARDEER 3022	3
2/4	North ST, LAKES ENTRANCE 3909	2

Director of Housing Properties for Rooming House Declaration

35	Northam RD, BENTLEIGH EAST 3165	3
5/40	Northcote AV, CAULFIELD NORTH 3161	3
12a	Northern Highway, ECHUCA 3564	3
12b	Northern Highway, ECHUCA 3564	2
1/14	O'Dea Crescent, KANGAROO FLAT 3555	2
2/14	O'Dea Crescent, KANGAROO FLAT 3555	2
1/124	Olive Avenue, MILDURA 3500	2
3/17	Olive GV, MENTONE 3194	2
19	Olivewood Drive, MILDURA 3500	2
19A	Olivewood Drive, MILDURA 3500	2
84	O'Neills RD, MELTON 3337	3
2/5	Orme ST, LAKES ENTRANCE 3909	2
7/40	Ormond RD, MOONEE PONDS 3039	2
108	Osbourne Street, BENDIGO 3550	2
58	Palmers RD, LAKES ENTRANCE 3909	3
5/50-54	Palmers RD, LAKES ENTRANCE 3909	2
79	Palmerstone ST, MELTON 3337	3
1	Pamela CT, MILLGROVE 3799	3
17	Panorama Drive, MILDURA 3500	3
53	Paramount DR, WHITTINGTON 3219	2
1/532	Pascoe Vale RD, PASCOE VALE 3044	2
3	Patricia Court, GOLDEN SQUARE 3555	3
118	Patten ST, SALE 3850	3
2/19	Patterson RD, MOORABBIN 3189	2
48	Penguin ST, MELTON 3337	3
3/16	Percy ST, MITCHAM 3132	2
11	Perry ST, ORBOST 3888	3
4/13	Peterson ST, LAKES ENTRANCE 3909	3
1/105	Plantation RD, CORIO 3214	2
3/65	Pollock ST, COLAC 3250	2
13	Power ST, ST ALBANS 3021	3
124	Power ST, ST ALBANS EAST 3021	3
28	Powlett ST, ALTONA MEADOWS 3028	3
16	Prince ST, BOX HILL 3128	3
205	Princes HWY, CORIO 3214	3
4/45	Princes HWY, LUCKNOW 3875	2
37	Princes HWY, NORLANE 3214	2
2/93	Princess HWY, BAIRNSDALE 3875	2
3/93	Princess HWY, BAIRNSDALE 3875	2
161/120	Racecourse RD, FLEMINGTON 3031	3

Director of Housing Properties for Rooming House Declaration

58/126	Racecourse RD, FLEMINGTON 3031	2
94/126	Racecourse RD, FLEMINGTON 3031	2
144/126	Racecourse RD, FLEMINGTON 3031	2
149/126	Racecourse RD, FLEMINGTON 3031	3
204/126	Racecourse RD, FLEMINGTON 3031	2
1	Rae ST, BENTLEIGH EAST 3165	3
12/47	Railway PL, FLEMINGTON 3031	2
3/2	Raleigh RD, FOOTSCRAY 3011	2
2/97-99	Raleigh RD, MARIBYRNONG 3032	2
5/533	Rathdowne ST, CARLTON 3053	3
8/523	Rathdowne ST, CARLTON 3053	3
1/1	Rayner ST, FOOTSCRAY 3011	2
67	Raynes Park RD, HAMPTON 3188	3
5/32	Reserve RD, HOPPERS CROSSING 3029	2
2/55	Ringwood ST, RINGWOOD 3134	2
2/7	Rippon GV, ELSTERNWICK 3185	2
11	Risbey Court, MILDURA 3500	2
12	Risbey Court, MILDURA 3500	2
12/596	Riversdale RD, CAMBERWELL 3124	2
31	Riversdale RD, YARRA JUNCTION 3797	3
1/65	Roadknight ST, LAKES ENTRANCE 3909	2
4/69	Roadknight ST, LAKES ENTRANCE 3909	3
89	Roberts ST, YARRAVILLE 3013	3
79	Robertson ST, MORWELL 3840	3
6	Rodleigh ST, CROYDON 3136	2
3/1A	Ronald AV, ALTONA NORTH 3025	2
2/24	Ronald ST, ESSENDON 3040	2
1/60	Rose ST, ALTONA 3018	2
1/27	Roseberry ST, ASCOT VALE 3032	2
2/15	Rosedale AV, GLENHUNTLY 3163	2
7	Rosehill ST, SCORESBY 3179	3
8/12	Rosella ST, MURRUMBEENA 3163	2
38	Rosewarne AV, CHELTENHAM 3192	3
5	Ross AV, MOE 3825	2
1/13	Ross ST, FERNTREE GULLY 3156	2
2	Ross ST, ST ALBANS 3021	3
1/44	Royal, CARNEGIE 3163	2
6/25	Royal AV, GLENHUNTLY 3163	2
2	Rundell AV, PORTLAND 3305	2
7/148	Rupert ST, FOOTSCRAY 3011	2

Director of Housing Properties for Rooming House Declaration

2/18	Rutherford Street, SWAN HILL 3585	2
3/18	Rutherford Street, SWAN HILL 3585	2
95	Rutherford Street, SWAN HILL 3585	3
1/33	Salisbury ST, MOONEE PONDS 3039	2
8/45-47	Sandown RD, ASCOT VALE 3032	2
2/14	Schofield ST, ESSENDON 3040	2
15B	Schulz ST, BENTLEIGH EAST 3165	3
1/14	Scotsburn GV, WERRIBEE 3030	2
4/10	Sebastopol ST, CAULFIELD 3162	2
4	Selwood ST, COLAC 3250	2
173	Service RD, MOE 3825	3
1/248	Seventh Street, MILDURA 3500	2
2	Shannon CL, WERRIBEE 3030	3
1/27	Shepparson AV, CARNEGIE 3163	3
1/32	Shepparson AV, CARNEGIE 3163	2
1/25	Sherwood Drive, BENDIGO 3550	2
2/25	Sherwood Drive, BENDIGO 3550	2
2/1	Short ST, BORONIA 3155	2
1/22	Sibley Place, BENDIGO 3550	2
2/22	Sibley Place, BENDIGO 3550	2
31	Sibley Place, BENDIGO 3550	3
2/133	Skene ST, WARRNAMBOOL 3280	2
14	Skye CT, CHELSEA HEIGHTS 3196	3
1/24	Slevin ST, LILYDALE 3140	2
45	Smith ST, KENSINGTON 3031	2
5/10	Smith ST, PORTLAND 3305	2
1/11	Solomon Street, BENDIGO 3550	3
2/11	Solomon Street, BENDIGO 3550	3
3/11	Solomon Street, BENDIGO 3550	3
5	Solomon Street, BENDIGO 3550	3
6	Solomon Street, BENDIGO 3550	3
643	South RD, BENTLEIGH EAST 3165	3
1/391	South RD, BRIGHTON EAST 3187	2
1/91	Spring RD, MOORABBIN 3189	3
2/10	Springfield AV, CLAYTON 3168	2
2/16	Springfield RD, BORONIA 3155	2
2/89	Springvale RD, NUNAWADING 3131	3
6/26	Springvale RD, NUNAWADING 3131	2
21	Sproats Lane, DONALD 3480	3
7	St Georges RD, NORLANE 3214	2

Director of Housing Properties for Rooming House Declaration

1/8	St Peters CT, BENTLEIGH EAST 3165	3
31	Stamford ST, MOE 3825	3
1/29	Stanley ST, ORBOST 3888	2
2/13	Stapley CR, ALTONA 3018	2
1/10	Station RD, MELTON 3337	2
927	Station ST, BOX HILL 3128	3
30	Station ST, CHELSEA 3196	2
31	Station ST, CHELSEA 3196	2
9/406	Station ST, CHELSEA 3196	2
55	Station ST, NORLANE 3214	2
2/22	Stawell ST, SALE 3850	2
16	Stead ST, SALE 3850	3
2/21	Stead ST, SALE 3850	3
1/5	Stephens RD, HEALESVILLE 3777	2
138	Stradbroke Avenue, SWAN HILL 3585	3
2/122	Stradbroke Avenue, SWAN HILL 3585	2
1/1094	Stud RD, ROWVILLE 3178	2
7/4	Sunkist Street, KANGAROO FLAT 3555	2
16	Sunrise DR, MULGRAVE 3170	3
1/109	Surrey RD, BLACKBURN 3130	2
4	Susi CT, NOBLE PARK 3174	3
23	Sutton Road, MARYBOROUGH 3465	3
43	Swallow CR, NORLANE 3214	2
3/43	Swan WK, CHELSEA 3196	2
11/14	Sydney ST, FOOTSCRAY 3011	3
24	Sydney ST, FOOTSCRAY 3011	2
2/12	Sydney ST, MURRUMBEENA 3163	2
26	Symons CR, MORWELL 3840	3
19	Syncline Court, BENDIGO 3550	3
43	Talford ST, DONCASTER 3108	3
3	Tamar DRV, MELTON 3337	3
66	Tarngower ST, YARRAVILLE 3013	2
13	Taylor CR, TRARALGON 3844	3
8	Taylor CT, COLAC 3250	3
48	Taylors LA, ROWVILLE 3178	2
5/83	Taylors RD, ST ALBANS 3021	2
8/11-13	Tennyson AV, KILSYTH 3137	3
15	Tennyson ST, KENSINGTON 3031	3
17	Tennyson ST, KENSINGTON 3031	3
1/126	Tennyson ST, ORBOST 3888	2

Director of Housing Properties for Rooming House Declaration

11	Tennyson ST, TRARALGON 3844	3
129	Thames PR, CHELSEA 3196	3
48	The Avenue , MORWELL 3840	3
7/188	The Parade , ASCOT VALE 3032	2
12/6	Thistle GV, HIGHETT 3190	2
88	Thistle ST, BENDIGO 3550	5
15	Thomas AV, MELTON SOUTH 3338	3
8	Thomas ST, BRIGHTON EAST 3187	2
5	Thomas ST, MORDIALLOC 3195	3
2	Thurleigh AV, CROYDON 3136	3
28	Tierny ST, WY YUNG 3875	3
3/13	Toolern ST, MELTON SOUTH 3338	2
4/1312	Toorak RD, BURWOOD	2
2/13	Tormore RD, BORONIA 3155	2
1/157	Torquay RD, GROVEDALE 3216	2
12	Trafalgar CR, LILYDALE 3140	3
1/37	Trethowan AVE, MELTON 3337	2
4	Trevatt Court, MILDURA 3500	5
2	Trivalve CR, TRARALGON 3844	3
15	Truscott RD, MOE 3825	2
2/198	Tucker RD, BENTLEIGH EAST 3165	3
1/59	Tunstall RD, DONVALE 3111	3
2/52	Turnbull ST, BAIRNSDALE 3875	2
87	Tyner RD, WANTIRNA SOUTH 3152	2
9/79	Union ST, BRIGHTON EAST 3187	2
14	Valetta ST, CARRUM 3197	3
12	Van Heurk Street, CASTLEMAINE 3450	3
2/50	Vanbrook ST, FOREST HILL 3131	2
31	Vary ST, MORWELL 3840	3
10/4	Vasey ST, ASCOT VALE 3032	2
50	Verner ST, GEELONG 3220	2
1/8	Veronica ST, FERNTREE GULLY 3156	2
1/13	Veronica ST, FERNTREE GULLY 3156	3
7/60	Victoria ST, FLEMINGTON 3031	3
18	Victoria ST, MOE 3825	2
1/92	Virgilia DR, HOPPERS CROSSING 3029	2
1/105	Virgilia DR, HOPPERS CROSSING 3029	2
1/14-16	Waddington CR, SPRINGVALE SOUTH 3172	3
1	Walker CT, ST ALBANS 3021	3
342	Walnut Avenue, MILDURA 3500	3

Director of Housing Properties for Rooming House Declaration

375A	Walnut Avenue, MILDURA 3500	2
3/3	Walsh CT, CHURCHILL 3842	3
1/11	Walter ST, ASCOT VALE 3032	2
7/8	Waratah AV, GLENHUNTLY 3163	2
23	Waratah DR, MORWELL 3840	3
21	Waratah Grove, ECHUCA 3564	3
2/40	Waratah ST, BENTLEIGH EAST 3165	3
1/15	Waratah ST, MELTON 3337	2
1/56	Warrandyte RD, RINGWOOD 3134	2
1/63	Warrandyte RD, RINGWOOD 3134	2
100	Warren RD, MORDIALLOC 3195	3
328	Warrigal RD, CHELTENHAM 3192	3
1/197	Warrigal RD, CHELTENHAM 3192	3
2/84	Warrigal RD, MENTONE 3194	2
2/17	Warwick ST, BENTLEIGH EAST 3165	2
85	Waters DR, ALTONA 3018	3
1/18	Watson Avenue, EAGLEHAWK 3556	2
5/2	Wattle AV, GLENHUNTLY 3163	3
2	Wattle GRV, SPRING GULLY 3550	2
1/143	Weatherall RD, CHELTENHAM 3192	2
9/117	Wellington ST, FLEMINGTON 3031	2
2	Welten DR, COLDSTREAM 3770	3
12	Welwood CT, CLAYTON SOUTH 3169	2
1/20	Wetherby RD, DONCASTER EAST 3109	2
2/6	Whatley ST, CARRUM 3197	3
5/1	White ST, PARKDALE 3195	2
2/1	Whitehall CT, CAULFIELD NORTH 3161	2
1/4	Wickham RD, HIGHETT 3190	3
1/134	Wickham RD, HIGHETT 3190	2
2/55	William ST, OAKLEIGH 3166	2
1/252	Williamsons RD, TEMPLESTOWE 3106	3
1/46	Wilson ST, CHELTENHAM 3192	2
3/23	Wimmera ST, BOX HILL NORTH 3129	2
86	Windsor ST, FOOTSCRAY 3011	2
4/17	Wingate AVE, ASCOT VALE 3032	2
2/1A	Woodstock PL, SPRINGVALE 3171	2
1/78	Woodville Park DR, HOPPERS CROSSING 3029	2
2/78	Woodville Park DR, HOPPERS CROSSING 3029	2
3/78	Woodville Park DR, HOPPERS CROSSING 3029	2
2/21	Wornack RD, CARNEGIE 3163	2

Director of Housing Properties for Rooming House Declaration

42	Worthing RD, MOORABBIN 3189	3
2/3	Wyrunga ST, RINGWOOD EAST 3135	2
1/19	Wyuna RD, CAULFIELD NORTH 3161	2
2/7	Yardley ST, MAIDSTONE 3012	2
2/5	York ST, BENDIGO 3550	2
1/18	Yvonne AV, CROYDON 3136	3
Total Properties 831		

Private Agents Act 1966NOTICE OF RECEIPT OF APPLICATIONS FOR LICENCES UNDER THE PROVISIONS OF
THE **PRIVATE AGENTS ACT 1966**

I, the undersigned, being a Deputy Registrar of the Magistrates' Court at Ballarat hereby give notice that applications, as under, have been lodged for hearing by the said Court on the date specified.

Any person desiring to object to any of such applications must:—

- (a) lodge with me a notice in the prescribed form of his objection and of the grounds thereof;
- (b) cause a copy of such notice to be served personally or by post upon the applicant at least three days before the hearing of the application; and
- (c) send or deliver
 - (i) where the objection is not made by the officer in charge of the police district in which the Court is situated — a copy of the notice to such officer; and
 - (ii) where the objection is not made by the Registrar or Deputy Registrar — a copy to the Registrar.

<i>Full name of Applicant or in the case of a Firm or Corporation, of the Nominee</i>	<i>Place of Abode of Applicant or Nominee</i>	<i>Name of Firm or Corporation</i>	<i>Address for Registration</i>	<i>Type of Licence</i>	<i>Date of Hearing of Application</i>
Roger Prescott	Trawalla House Trawalla 3373		13A, 315 Sturt Street Ballarat 3350	Commer- cial Agent (Indivi- dual)	29/10/01

Dated at Ballarat 8 October 2001

P. BROWN
Deputy Registrar of the Magistrates' Court

Private Agents Act 1966NOTICE OF RECEIPT OF APPLICATIONS FOR LICENCES UNDER THE PROVISIONS OF
THE **PRIVATE AGENTS ACT 1966**

I, the undersigned, being a Deputy Registrar of the Magistrates' Court at Moe hereby give notice that applications, as under, have been lodged for hearing by the said Court on the date specified.

Any person desiring to object to any of such applications must:—

- (a) lodge with me a notice in the prescribed form of his objection and of the grounds thereof;
- (b) cause a copy of such notice to be served personally or by post upon the applicant at least three days before the hearing of the application; and

- (c) send or deliver
- (i) where the objection is not made by the officer in charge of the police district in which the Court is situated — a copy of the notice to such officer; and
 - (ii) where the objection is not made by the Registrar or Deputy Registrar — a copy to the Registrar.

<i>Full name of Applicant or in the case of a Firm or Corporation, of the Nominee</i>	<i>Place of Abode of Applicant or Nominee</i>	<i>Name of Firm or Corporation</i>	<i>Address for Registration</i>	<i>Type of Licence</i>	<i>Date of Hearing of Application</i>
Mark Gregory Answerth	8 Gillies Crescent, Traralgon		8 Gillies Crescent, Traralgon	Commercial Agent	31/10/01

Dated at Moe 10 October 2001

Brian Geary
Deputy Registrar of the Magistrates' Court



Legal Practice Board

NOTICE OF ELECTION

2001 Elections of Practitioner Members

Notice is hereby given in accordance with the Legal Practice (Board Elections) Regulations 1997 that elections will be held on Tuesday 4 December 2001 at 5.00 p.m to fill positions of:-

- (i) one (1) practitioner member to the Legal Practice Board by enrolled current practitioners, enrolled on the Roll of Advocates, and
- (ii) one (1) practitioner member to the Legal Practice Board by enrolled current practitioners, enrolled on the Roll of Non-Advocates.

Eligibility

- To be eligible to vote at the elections, current practitioners (being legal practitioners holding a current practising certificate) must enrol by giving written notice to the Board at Level 19, 385 Bourke Street, Melbourne 3000 by the close of roll date of 5.00 p.m. on Thursday 25 October 2001. Those practitioners already enrolled for the year 1 July 2001 – 30 June 2002 do not need to further enrol.
- To be eligible for election to the Legal Practice Board a current practitioner must be a legal practitioner of not less than 7 years standing and be enrolled as an elector on either the Roll of Advocates or the Roll of Non-Advocates.

Positions

- The elections will be for one (1) practitioner member elected from the Roll of Advocates and one (1) practitioner member elected from the Roll of Non-Advocates. The successful candidates terms of office will be from 1 January 2002 until 31 December 2005.

Nominations

- Nominations from enrolled practitioners are hereby called for and must be received by the Returning Officer, Mr Douglas Wellington, Election Desk, at either 42 Patyah Street, Diamond Creek 3089 or PO Box 410, Greensborough, 3088 not later than 12.00 noon on Thursday 1 November 2001.
- Each nomination must be signed by two nominators **WHO SHALL BE CURRENT PRACTITIONERS ENROLLED TO VOTE AT THE ELECTION**. The nominees, who must also be current practitioners, must sign the declaration of consent to nomination on the

Nomination Form.

- A Nomination Package may be obtained from the Returning Officer, telephones (03) 9438 5810 / mobile 0414 704 474 or from Ms Ann Kinnear at the Legal Practice Board, telephone (03) 9679 5551.
- Candidates may supply with their nomination a recent passport size photograph and a personal statement of not more than 250 words. A candidate cannot in his or her personal statement refer to another candidate standing in the election without lodging the written consent of that other candidate with the statement.
- The Returning Officer may also amend or reject a personal statement in consultation with the candidate.
- A candidate who lodges a personal statement is responsible for the accuracy and integrity of all statements contained in it.
- Candidates may withdraw their nominations by notice in writing lodged with the Returning Officer at any time before the commencement of the scrutiny of votes in the election.

Voting Arrangements

If a ballot is required to decide the election, a draw to determine the order of the candidates names on the ballot paper will be conducted by the Returning Officer at the Legal Practice Board at 10.00 a.m. on Friday 2 November 2001.

- Voting papers will be posted to each practitioner on the rolls on Tuesday 20 November 2001.
- Votes must be received by the Returning Officer no later than 5.00 p.m. on Tuesday 4 December 2001.

W. J. ROBINSON
Chief Executive Officer

Planning and Environment Act 1987

CARDINIA PLANNING SCHEME

Notice of Approval of Amendment

Amendment C2

The Minister for Planning has approved Amendment C2 to the Cardinia Planning

Scheme.

The Amendment comes into operation on the date this notice is published in the Government Gazette.

The Amendment rezones the land (known as Part Crown Allotment 34, Parish of Pakenham) from a Rural Zone to a Residential 1 Zone and Public Use Zone 6 (Local Government) and deletes the Environmental Significance Overlay (Schedule 1) applying to the land and includes the land in a Development Plan Overlay (Schedule 4).

A copy of the Amendment can be inspected, free of charge, during office hours, at the Department of Infrastructure, Planning Information Centre, Upper Plaza, Nauru House, 80 Collins Street, Melbourne and at the municipal offices of the Cardinia Shire Council, Henty Way, Pakenham.

PAUL JEROME
Executive Director
Planning, Heritage and
Building Division
Department of Infrastructure

Planning and Environment Act 1987

EAST GIPPSLAND PLANNING SCHEME

Notice of Approval of Amendment

Amendment C9

The Minister for Planning has approved Amendment C9 to the East Gippsland Planning Scheme.

The Amendment comes into operation on the date this notice is published in the Government Gazette.

The Amendment corrects four minor map errors as follows:

- Rezones CA 15, 16 Bonang Highway, Goongerah from Public Conservation Resource Zone to Rural Zone.
- Rezones Part CA 14a Wiseleigh from Public Conservation Resource zone to Rural zone.
- Corrects the mapping of Heritage Overlay site HO144 by applying it to the property at 158 Princes Highway, Lucknow.
- Corrects the mapping of Heritage Overlay site HO132 by applying it to the property at

28 Pearson Street, Bairnsdale,

A copy of the Amendment can be inspected, free of charge, during office hours, at the Department of Infrastructure, Planning Information Centre, Upper Plaza, Nauru House, 80 Collins Street, Melbourne and at the offices of the East Gippsland Shire Council, 273 Main Street, Bairnsdale.

PAUL JEROME
Executive Director
Planning, Heritage and
Building Division
Department of Infrastructure

Planning and Environment Act 1987

HORSHAM PLANNING SCHEME

Notice of Approval of Amendment

Amendment C6

The Minister for Planning has approved Amendment C6 to the Horsham Planning Scheme.

The Amendment comes into operation on the date this notice is published in the Government Gazette.

The Amendment rezones land known as Part PC 362457U and Lots 36 and 37 of LP 3137 Part CA 6, Section 8, Parish of Horsham which fronts the Western Highway at Horsham from the Rural Zone to the Business 4 Zone.

A copy of the Amendment can be inspected, free of charge, during office hours, at the Department of Infrastructure, Planning Information Centre, Upper Plaza, Nauru House, 80 Collins Street, Melbourne; at the Department of Infrastructure, Western Regional Office, 88 Learmonth Road, Wendouree and at the offices of the Horsham Rural City Council, Roberts Avenue, Horsham.

PAUL JEROME
Executive Director
Planning, Heritage and
Building Division
Department of Infrastructure

Planning and Environment Act 1987

MORELAND PLANNING SCHEME

Notice of Approval of Amendment

Amendment C7

The Minister for Planning has approved Amendment C7 to the Moreland Planning

Scheme.

The Amendment comes into operation on the date this notice is published in the Government Gazette.

The Amendment:

- Rezones land east of the former Pentridge Prison between Bell Street and Murray Road, Coburg known as Crown Allotment 17, Section 2, Township of Coburg, Parish of Jika Jika from Public Use Zone 2 to Residential 1 Zone with an Environmental Audit Overlay.

A copy of the Amendment can be inspected, free of charge, during office hours, at the Department of Infrastructure, Planning Information Centre, Upper Plaza, Nauru House, 80 Collins Street, Melbourne and at the offices of the Moreland City Council, 90 Bell Street, Coburg.

PAUL JEROME
Executive Director
Planning, Heritage and
Building Division
Department of Infrastructure

Planning and Environment Act 1987

WHITTLESEA PLANNING SCHEME

Notice of Approval of Amendment

Amendment C14

The Minister for Planning has approved Amendment C14 to the Whittlesea Planning Scheme.

The Amendment comes into operation on the date this notice is published in the Government Gazette.

The Amendment:

- Rezones land at 480 Cooper Street, Epping from Special Use 4 Zone to Industrial 1 Zone;
- Includes the land at 480 Cooper Street, Epping in a Design and Development Overlay; and
- Inserts a schedule to the Design and Development to identify the site at 480 Cooper Street as having previously been used for the disposal of putrescible waste for which specific design requirements for

development would be required.

A copy of the Amendment can be inspected, free of charge, during office hours, at the Department of Infrastructure, Planning Information Centre, Upper Plaza, Nauru House, 80 Collins Street, Melbourne and at the offices of the Whittlesea City Council, Ferres Boulevard, South Morang.

PAUL JEROME
Executive Director
Planning, Heritage and
Building Division
Department of Infrastructure

Planning and Environment Act 1987

NOTICE OF DECLARATION OF PROJECT
UNDER SECTION 201F

I, John Thwaites, Minister for Planning, by this notice declare the Regional Fast Rail Project to be a development of State or regional significance.

In this notice, the "Regional Fast Rail Project" means the upgrade of Victoria's metropolitan and country infrastructure required for the introduction of new fast rail services to the four Victorian regional centres of Ballarat, Bendigo, Geelong and the Latrobe Valley.

Dated 3 October 2001

JOHN THWAITES
Minister for Planning

ORDERS IN COUNCIL

Administrative Arrangements Act 1983

ADMINISTRATIVE ARRANGEMENTS ORDER (No. 171) 2001

The Governor in Council makes the following Order:

- 1. Title**
This Order is called the **Administrative Arrangements Order (No. 171) 2001**.
- 2. Authorising provision**
This Order is made under section 4 of the **Administrative Arrangements Act 1983**.
- 3. Commencement**
This Order takes effect on 1 July 2001.
- 4. Definition**
“**Old Body**” means the Department specified in Column 3 in the Schedule;
“**New Body**” means the Department specified in Column 4 in the Schedule;
“**Schedule**” means the Schedule to this Order.
- 5. Transfer of Moneys**
As the function specified in Column 1 of the Schedule was transferred on 1 July 2001 from the Old Body to the New Body and, before the transfer, moneys appropriated by the **Appropriation (2001/2002) Act 2001** “Provision of outputs” and moneys appropriated by the **Appropriation (2000/2001) Act 2000** “Provision of outputs” (approved for carryover under section 32 of the **Financial Management Act 1994**) had been lawfully issued or applied for or in respect of the performance by the Old Body of that function, it is directed that the moneys specified in Column 2 may be issued and applied for, to or in respect of the performance by the New Body of that function.

SCHEDULE

Column 1 (Function)	Column 2 (Amount)	Column 3 Old Body	Column 4 New Body
Chipskills Project	\$3,400,000 (being the total of \$2,000,000 appropriated by the Appropriation (2001/2002) Act 2001 and \$1,400,000 appropriated by the Appropriation (2000/2001) Act 2000 and approved for carryover under section 32 of the Financial Management Act 1994).	Department of Education, Employment and Training	Department of State and Regional Development

Dated 16 October 2001

Responsible Minister:
S. P. BRACKS
Premier

HELEN DOYE
Clerk of the Executive Council

BLF (De-recognition) Act 1985

EXTENSION OF PREVIOUS ORDERS

The Governor in Council under section 7 of the **BLF (De-recognition) Act 1985** orders that the following Orders made under the Act are extended in duration until 17 April 2002:

1. Order dated 13 October 1987 and published in the Government Gazette on 13 October 1987; and
2. Order dated 10 November 1987 and published in the Government Gazette on 10 November 1987; and
3. Order dated 22 December 1987 and published in the Government Gazette on 22 December 1987; and
4. Order dated 12 April 1988 and published in the Government Gazette on 12 April 1988; and
5. Order dated 17 May 1988 and published in the Government Gazette on 18 May 1988; and
6. Order dated 11 October 1988 and published in the Government Gazette on 12 October 1988; and
7. Order dated 21 March 1989 and published in the Government Gazette on 22 March 1989; and
8. Order dated 12 September 1989 and published in the Government Gazette on 13 September 1989; and
9. Order dated 20 February 1990 and published in the Government Gazette on 21 February 1990; and
10. Order dated 7 August 1990 and published in the Government Gazette on 8 August 1990; and
11. Order dated 22 January 1991 and published in the Government Gazette on 23 January 1991; and
12. Order dated 16 July 1991 and published in the Government Gazette on 17 July 1991; and
13. Order dated 26 November 1991 and published in the Government Gazette on 27 November 1991; and
14. Order dated 12 May 1992 and published in the Government Gazette on 13 May 1992; and
15. Order dated 27 October 1992 and published in the Government Gazette on 28 October 1992; and
16. Order dated 6 April 1993 and published in the Government Gazette on 8 April 1993; and
17. Order dated 28 September 1993 and published in the Government Gazette on 30 September 1993; and
18. Order dated 16 March 1994 and published in the Government Gazette on 17 March 1994; and
19. Order dated 6 September 1994 and published in the Government Gazette on 8 September 1994; and
20. Order dated 28 February 1995 and published in the Government Gazette on 2 March 1995; and
21. Order dated 22 August 1995 and published in the Government Gazette on 24 August 1995; and
22. Order dated 20 February 1996 and published in the Government Gazette on 22 February 1996; and
23. Order dated 20 August 1996 and published in the Government Gazette on 20 August 1996; and
24. Order dated 11 February 1997 and published in the Government Gazette on 13 February 1997; and
25. Order dated 5 August 1997 and published in the Government Gazette on 7 August 1997; and
26. Order dated 3 February 1998 and published in the Government Gazette on 5 February 1998; and
27. Order dated 28 July 1998 and published in the Government Gazette on 30 July 1998; and
28. Order dated 15 December 1998 and published in the Government Gazette on 17 December 1998; and
29. Order dated 8 June 1999 and published in the Government Gazette on 10 June 1999; and
30. Order dated 30 November 1999 and published in the Government Gazette on 2 December 1999; and

31. Order dated 16 May 2000 and published in the Government Gazette on 18 May 2000; and
32. Order dated 8 November 2000 and published in the Government Gazette on 9 November 2000; and
33. Order dated 24 April 2001 and published in the Government Gazette on 26 April 2001; and
34. Order dated 7 August 2001 and published in the Government Gazette on 7 August 2001.

Dated 16 October 2001

Responsible Minister:

MONICA GOULD

Minister for Industrial Relations

HELEN DOYE

Clerk of the Executive Council

**Intellectually Disabled Persons
Services Act 1986**

ORDER REVOKING APPOINTMENT OF
ADMINISTRATOR OF BROADMEADOWS
ADULT TRAINING AND SUPPORT
SERVICE

Under section 25(1) of the **Intellectually Disabled Persons' Services Act 1986** ("the Act") and on the recommendation of the Minister for Community Services, the Governor in Council **REPEALS** the Order made by the Governor in Council dated 24 September 1996 appointing Elizabeth Bishop as administrator of Broadmeadows Adult Training and Support Service.

This Order-in-Council is to take effect from the date of publication in the Government Gazette.

Dated 16 October 2001

Responsible Minister:

HON CHRISTINE CAMPBELL MP,

Minister for Community Services

HELEN DOYE

Clerk of the Executive Council

Crown Land (Reserves) Act 1978

NOTICE OF INTENTION TO REVOKE
TEMPORARY RESERVATIONS

The Governor in Council under section 10 of the **Crown Land (Reserves) Act 1978** gives notice of intention to revoke the following temporary reservations:

BEECHWORTH — The temporary reservation by Order in Council of 22 September, 1884 of an area land in the Parish of Beechworth (in three [3] separate strips) as a site for Water Supply purposes, revoked as to part by various Orders, so far only as the portion containing 3866 square metres shown as Crown Allotment 13K, Section Q2, Parish of Beechworth on Original Plan No. 121483 lodged in the Central Plan Office. — (Rs 8588).

KILLINGWORTH — The temporary reservation by Order in Council of 23 September, 1986 of an area of 7.6 hectares, more or less, of land being Crown Allotment 38B, Parish of Killingworth as a site for Public Recreation and Camping, so far only as the portion containing 5.281 hectares shown as Crown Allotment 2001, Parish of Killingworth on Original Plan No. 121511 lodged in the Central Plan Office. — (Rs 2237).

This Order is effective from the date on which it is published in the Government Gazette.

Dated 16 October 2001

Responsible Minister

SHERRYL GARBUTT

Minister for Environment

and Conservation

HELEN DOYE

Clerk of the Executive Council

Crown Land (Reserves) Act 1978

REVOCATION OF TEMPORARY
RESERVATIONS

The Governor in Council under section 10 of the **Crown Land (Reserves) Act 1978** revokes the following temporary reservations:

COWWARR — The temporary reservation by Order in Council of 19 October, 1971 of an area of 8094 square metres of land in the Township of Cowwarr, Parish of Toongabbie as a site for State School purposes. — (Rs 3016).

MARYBOROUGH — The temporary reservation by Order in Council of 9 May, 1892 of an area of 3248 square metres of land in Section 19A, Township of Maryborough, Parish of Maryborough (formerly municipal district of Maryborough) as a site for Drainage purposes, revoked as to part by Order in Council of 28 October, 1997 so far only as the portion

containing 186 square metres shown as Crown Allotment 17A, Section 19A, Township of Maryborough, Parish of Maryborough on Original Plan No. 121341 lodged in the Central Plan Office. — (Rs 2292).

MIRNEE — The temporary reservation by Order in Council of 28 August, 1984 of an area of 2.750 hectares of land being Crown Allotment 71D, Parish of Mirnee as a site for Municipal purposes. — (Rs 12751).

MORTLAKE — The temporary reservation by Order in Council of 8 May, 1893 of an area of 8.456 hectares of land in Section 7, Parish of Mortlake (formerly Crown Allotment 29, Section 7) as a site for Watering purposes. — (Rs 43049)

This Order is effective from the date on which it is published in the Government Gazette.

Dated 16 October 2001

Responsible Minister
SHERRYL GARBUTT
Minister for Environment
and Conservation

HELEN DOYE
Clerk of the Executive Council

Crown Land (Reserves) Act 1978
REVOCATION OF TEMPORARY
RESERVATIONS

The Governor in Council under section 10 of the **Crown Land (Reserves) Act 1978** revokes the following temporary reservations:

KOONWARRA — The temporary reservation by Order in Council of 1 July, 1997 of an area of land in the Township of Koonwarra as a site for Public Purposes (Rail Trail), so far only as the portion containing 3.564 hectares shown as Parcel No. 2 on Roads Corporation Plan No. SP 19877. — (2000791).

KOONWARRA — The temporary reservation by Order in Council of 1 July, 1997 of an area of land in the Township of Koonwarra as a site for Public Purposes (Rail Trail), so far only as the portion containing 8717 square metres shown as Parcel No. 1 on Roads Corporation Plan No. SP 19878. — (2000791).

MERINGUR — The temporary reservation by Order in Council of 27 March, 1945 of an area of 1.761 hectares, more or less, of land in

Section A, Township of Meringur, Parish of Meringur as a site for a State School, in addition to and adjoining the site temporarily reserved therefor by Order in Council of 4 May, 1927. — (Rs 3449).

MERINGUR — The temporary reservation by Order in Council of 3 December, 1948 of an area of 1.518 hectares, more or less, of land in Section J, Township of Meringur, Parish of Meringur as a site for State School purposes, in addition to and adjoining the site temporarily reserved therefor by Order in Council of 4 May, 1927. — (Rs 3449).

MERINGUR — The temporary reservation by Order in Council of 3 December, 1948 of an area of 632 square metres, more or less, of land in Section A, Township of Meringur, Parish of Meringur as a site for State School purposes, in addition to and adjoining the site temporarily reserved therefor by Order in Council of 4 May, 1927. — (Rs 3449).

NINDOO — The temporary reservation by Order in Council of 3 March, 1890 of an area of 1.61 hectares of land in the Parish of Nindoo as a site for a State School. — (Rs 14257)

This Order is effective from the date on which it is published in the Government Gazette.

Dated 16 October 2001

Responsible Minister
SHERRYL GARBUTT
Minister for Environment
and Conservation

HELEN DOYE
Clerk of the Executive Council

Crown Land (Reserves) Act 1978
TEMPORARY RESERVATION OF
CROWN LANDS

The Governor in Council under section 4(1) of the **Crown Land (Reserves) Act 1978** temporarily reserves the following Crown lands which in his opinion are required for the purposes mentioned:—

MUNICIPAL DISTRICT OF THE
RURAL CITY OF ARARAT

ARARAT — Conservation of an area of natural interest, 3.636 hectares, being Crown Allotment 70C, Section 3A, Parish of Ararat as indicated by hatching on plan hereunder. (A149[27]) — (P103349)

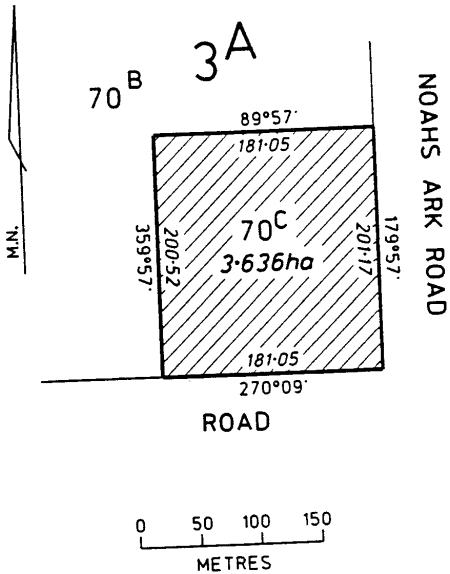

MUNICIPAL DISTRICT OF THE CITY OF BALLARAT

DOWLING FOREST — Management of Wildlife, 2.568 hectares, being Crown Allotment 13A, Section 3, Parish of Dowling Forest as indicated by hatching on plan hereunder. (Parish 2542) — (Rs 13342).

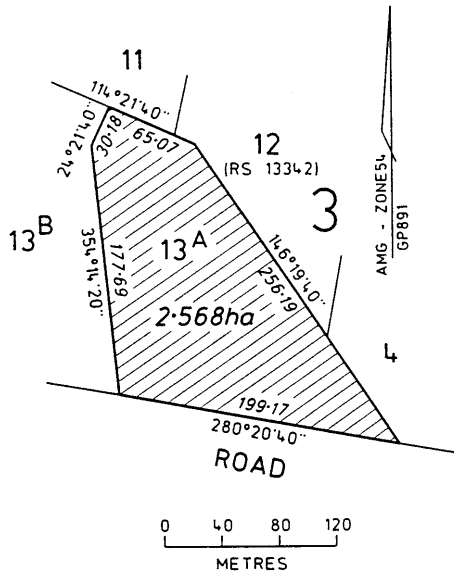

MUNICIPAL DISTRICT OF THE SURF COAST SHIRE COUNCIL

LORNE — Police purposes, 963 square metres, being Crown Allotment 2J, No Section, Township of Lorne, Parish of Lorne as shown on

Original Plan No. 121283 lodged in the Central Plan Office. — (0511829).

MUNICIPAL DISTRICT OF THE HORSHAM RURAL CITY COUNCIL

NURRABIEL — Management of Wildlife and Preservation of Wildlife Habitat, 65 hectares, more or less, being Crown Allotment 2A, No Section, Township of Nurrabiel, Parish of Nurrabiel as indicated by hatching on plan hereunder. (N103[5]) — (Rs 35104).

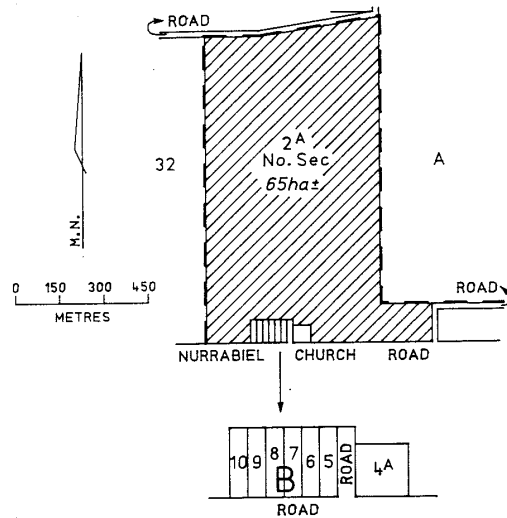

MUNICIPAL DISTRICT OF THE HINDMARSH SHIRE COUNCIL

WATCHEGATCHECA — Management of Wildlife and Preservation of Wildlife Habitat, 16.50 hectares, more or less, being Crown Allotment 2001, Parish of Watchegatcheca as indicated by hatching on plan hereunder. (W329[4]) — (Rs 35103).

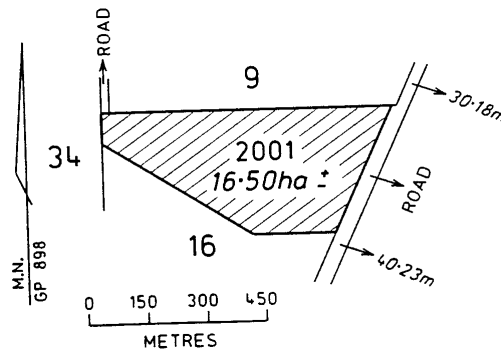

MUNICIPAL DISTRICT OF THE
SOUTHERN GRAMPIANS SHIRE COUNCIL
YATCHAW EAST — Management of Wildlife
and Preservation of Wildlife Habitat, 56.97
hectares, being Crown Allotment 3A, Section 2,
Parish of Yatchaw East as shown on Certified
Plan No. 107281 lodged in the Central Plan
Office. — (Rs 12179).

This Order is effective from the date on
which it is published in the Government
Gazette.

Dated 16 October 2001

Responsible Minister
SHERRYL GARBUTT
Minister for Environment
and Conservation

HELEN DOYE
Clerk of the Executive Council

Crown Land (Reserves) Act 1978

**DISSOLUTION OF INCORPORATED
COMMITTEES OF MANAGEMENT**

The Governor in Council under section
14A(7) of the **Crown Land (Reserves) Act
1978** dissolves the:—

“Apollo Bay Foreshore Reserve Committee
of Management Incorporated” constituted
by Order in Council of 24 July, 1990 (vide
Government Gazette of 1 August, 1990 –
page 2387) [Rs 4917] and

the “Apollo Bay Cricket and Recreation
Reserve Incorporated” constituted by Order
in Council of 1 December, 1998 (vide
Government Gazette of 3 December, 1998 –
page 2960) [Rs 72].

This Order is effective from the date on
which it is published in the Government
Gazette.

Dated 16 October 2001

Responsible Minister
SHERRYL GARBUTT
Minister for Environment
and Conservation

HELEN DOYE
Clerk of the Executive Council

Land Act 1958

CLOSURE OF UNUSED ROADS

The Governor in Council under section 349
of the **Land Act 1958** and with the concurrence
in writing of the municipalities in which the
roads are situated closes the following unused
roads:

MUNICIPAL DISTRICT OF THE
DELATITE SHIRE COUNCIL

GOORAMBAT — The road in the Parish of
Goorambat as indicated by hatching on plan
hereunder. (G173[3]) — (P161351).

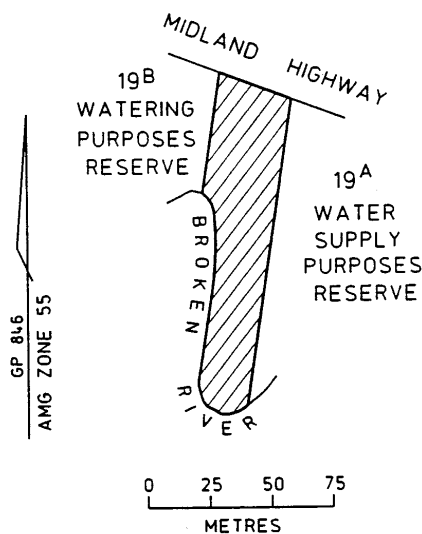

MUNICIPAL DISTRICT OF THE NORTHERN
GRAMPIANS SHIRE COUNCIL

STAWELL — The roads in the Parish of Stawell
as indicated by hatching on plan
hereunder. (Parish 3499[2]) — (02/7914).

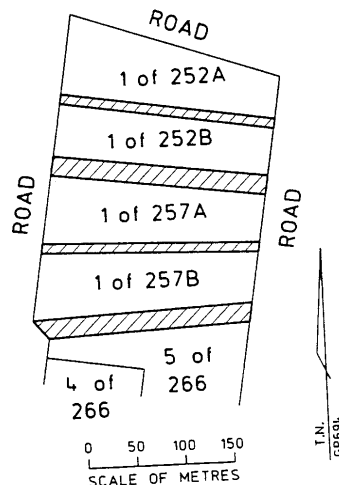

This Order is effective from the date on which it is published in the Government Gazette.

Dated 16 October 2001

Responsible Minister
SHERRYL GARBUTT
Minister for Environment
and Conservation

HELEN DOYE
Clerk of the Executive Council

Land Act 1958

CLOSURE OF UNUSED ROADS

The Governor in Council under section 349 of the **Land Act 1958** and with the concurrence in writing of the municipalities in which the roads are situated and the owners of land adjoining those roads closes the following unused roads:-

MUNICIPAL DISTRICT OF THE PYRENEES SHIRE COUNCIL

LANDSBOROUGH — The roads in the Parish of Landsborough shown as Crown Allotments 2001 and 2002, No Section on Original Plan No. 121508 lodged in the Central Plan Office. — (06/L6-10570).

MUNICIPAL DISTRICT OF THE SURFCOAST SHIRE COUNCIL

MIRNEE — The road in the Parish of Mirnee as indicated by hatching on plan hereunder. (M118[3]) — (05/12061).

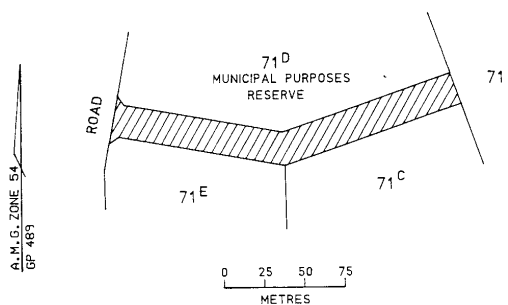

MUNICIPAL DISTRICT OF THE MACEDON RANGES SHIRE COUNCIL

MONEGEETTA — The road in the Parish of Monegeetta shown as Crown Allotment 26F, Section C on Original Plan No. 121476 lodged in the Central Plan Office.— (07/3430).

MUNICIPAL DISTRICT OF THE CORANGAMITE SHIRE COUNCIL

TIMBOON — The road in the Parish of Timboon shown as Crown Allotment 74M on Original Plan No. 121463 lodged in the Central Plan Office. — (05/98-1046).

MUNICIPAL DISTRICT OF THE MITCHELL SHIRE COUNCIL

TOOBORAC — The roads in the Parish of Tooborac being Crown Allotments 2001 and 2002, Section B, as indicated by hatching on plan hereunder. (T91[7]) — (P182633).

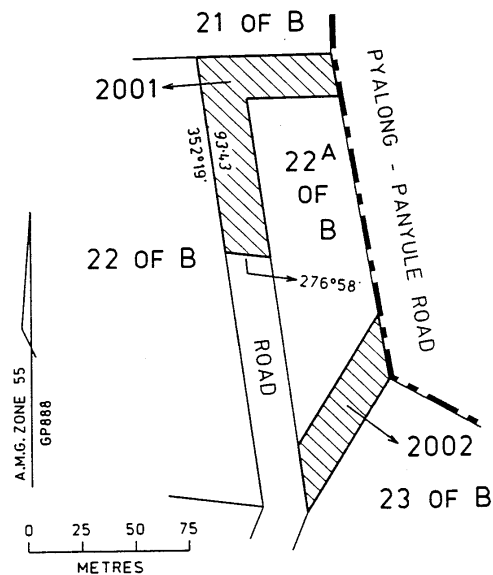

TRAAWOOL — The road in the Parish of Traawool, being Crown Allotment 2001, as indicated by hatching on plan hereunder. (Parish 3645) — (P180785).

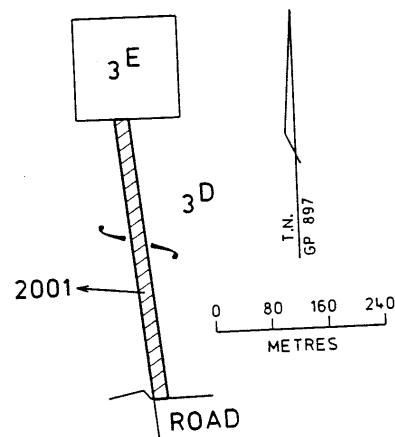

This Order is effective from the date on which it is published in the Government Gazette.

Dated 16 October 2001

Responsible Minister
 SHERRYL GARBUTT
 Minister for Environment
 and Conservation

HELEN DOYE
 Clerk of the Executive Council

Forests Act 1958

EXCHANGE OF RESERVED FOREST FOR CROWN LAND

The Governor in Council under section 49(1) of the **Forests Act 1958** authorises, in exchange for the Crown land described in the Dedication Schedule hereunder, the excision of the lands described in the Excision Schedule hereunder from reserved forest.

DEDICATION SCHEDULE

An area of 155.26 hectares, more or less, of Crown land comprising –

105.7 hectares in the Parish of Barwongemoong as indicated by hatching on the plan hereunder. (B742[5]) — (L1-4283).

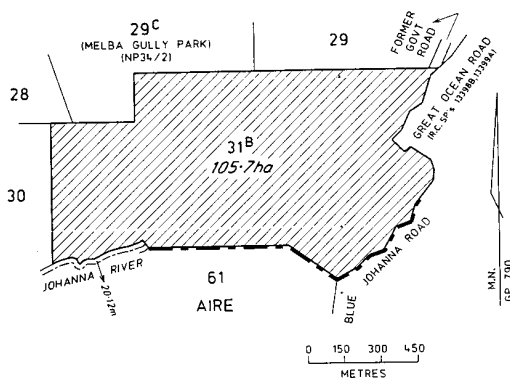

49.56 hectares in the Parish of Wyelangta as indicated by hatching on the plan hereunder. (W358[6]) — 2007729).

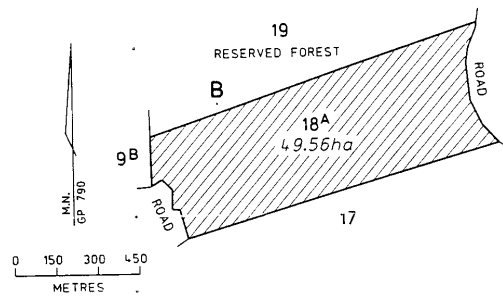

EXCISION SCHEDULE

An area of 77.07 hectares, more or less, of reserved forest comprising –

43 hectares, more or less, in the Parish of Lexington being Crown Allotment 9C, Section 15 as indicated by hatching on plan hereunder. (L39(7) — (2003750).

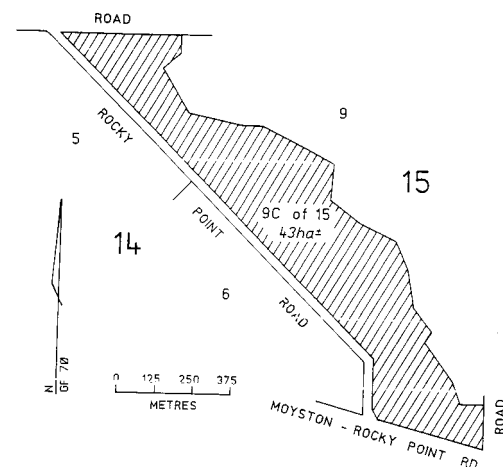

33.05 hectares, more or less, in the Parish of Creswick being Crown Allotment 5B, Section S as indicated by hatching on plan hereunder. (C400(A12)) — (2007370).

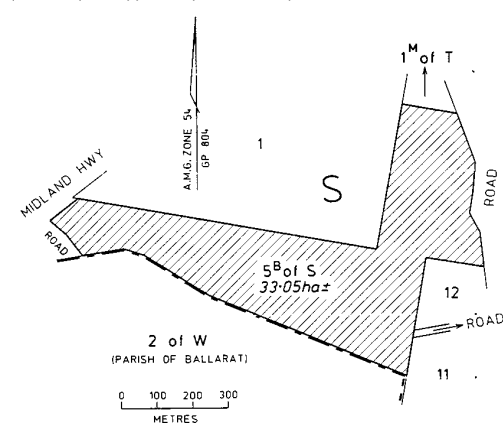

4999 square metres being Crown Allotments 9A and 9B Section 6, Parish of Bright as shown on Original Plan No 120724 lodged in the Central Plan Office. — (P201452).

5194 square metres being Crown Allotment 1D, Section 6, Township of Coopers Creek, Parish of Numbruk as shown on Original Plan No 121195 lodged in the Central Plan Office. — (P262681)

Such excisions and dedications to come into effect on the fourteenth day after publication of this Order in the Government Gazette.

Dated 16 October 2001

Responsible Minister
SHERRYL GARBUTT
Minister for Environment
and Conservation

HELEN DOYE
Clerk of the Executive Council

- (a) Under the heading "Category 2 Councils" **insert** "Melton Shire Council"; and
- (b) Under the heading "Category 2 Councils" for "Wangaratta Regional Council" **substitute** "Wangaratta Rural City Council".

Dated 16 October 2001

Responsible Minister:
BOB CAMERON
Minister for Local Government

HELEN DOYE
Clerk of the Executive Council

Local Government Act 1989
and Interpretation of Legislation Act 1984
AMENDMENT TO ORDER IN COUNCIL
FIXING AND LIMITING ALLOWANCES
UNDER SECTION 74 OF THE **LOCAL**
GOVERNMENT ACT 1989 FOR THE
COUNCILLORS AND MAYORS OF ALL
COUNCILS OTHER THAN MELBOURNE
CITY COUNCIL

The Governor in Council acting under section 27 of the **Interpretation of Legislation Act 1984** and section 74 of the **Local Government Act 1989** makes the following Order-

Commencement

1. This Order commences operation on 16 October 2001.

Interpretation

2. In this Order a reference to a section is a reference to a section of the **Local Government Act 1989**.

Amendment

3. The Schedule to the Order in Council fixing and limiting allowances under section 74 of the **Local Government Act 1989** for the councillors and mayors of all councils other than Melbourne City Council as published in the Government Gazette on 29 March 2001 is amended on the commencement of the operation of this Order as follows-

**SUBORDINATE LEGISLATION ACT 1994
NOTICE OF MAKING OF STATUTORY
RULES**

Notice is hereby given under Section 17 (2) of the **Subordinate Legislation Act 1994** of the making of the following Statutory Rules:

105. *Statutory Rule:* Evidence (Affidavits and Statutory Declarations) (Amendment) Regulations 2001
Authorising Act: Evidence Act 1958
Date of making: 16 October 2001
106. *Statutory Rule:* Magistrates' Court General (Further Infringements) Regulations 2001
Authorising Act: Magistrates' Court Act 1989
Date of making: 16 October 2001
107. *Statutory Rule:* Motor Car Traders (Fees) Regulations 2001
Authorising Act: Motor Car Traders Act 1986
Date of making: 16 October 2001
108. *Statutory Rule:* Pharmacists (Fees) Regulations 2001
Authorising Act: Pharmacists Act 1974
Date of making: 16 October 2001
109. *Statutory Rule:* Cemeteries (Incorporation of Trusts) (Further Amendment) Regulations 2001
Authorising Act: Cemeteries Act 1958
Date of making: 16 October 2001

**SUBORDINATE LEGISLATION ACT 1994
NOTICE THAT STATUTORY RULES ARE
OBTAINABLE**

Notice is hereby given under Section 17 (3) of the **Subordinate Legislation Act 1994** that the following Statutory Rules were first obtainable from Information Victoria, 356 Collins Street, Melbourne on the date specified:

98. *Statutory Rule:* Petroleum (Submerged Lands) Regulations 2001
Authorising Act: Petroleum (Submerged Lands) Act 1982
Date first obtainable: 15 October 2001
Code A
99. *Statutory Rule:* Subordinate Legislation (Mineral Resources (Titles) Regulations 1991 - Extension of Operation) Regulations 2001
Authorising Act: Subordinate Legislation Act 1994
Date first obtainable: 15 October 2001
Code A
100. *Statutory Rule:* Subordinate Legislation (Mineral Resources (Health and Safety) Regulations 1991 - Extension of Operation) Regulations 2001
Authorising Act: Subordinate Legislation Act 1994
Date first obtainable: 15 October 2001
Code A
101. *Statutory Rule:* Subordinate Legislation (Mineral Resources (Royalties) Regulations 1991 - Extension of Operation) Regulations 2001
Authorising Act: Subordinate Legislation Act 1994
Date first obtainable: 15 October 2001
Code A

**SUBORDINATE LEGISLATION ACT 1994
NOTICE THAT STATUTORY RULES ARE
OBTAINABLE**

Retail price will vary according to the number of pages in each special or periodical gazette. The table below sets out the prices that apply.

		<i>No. of Pages</i>		
		<i>(Including cover</i>		
		<i>Price Code</i>	<i>and blank pages)</i>	<i>Price*</i>
102. Statutory Rule:	Subordinate Legislation (Mineral Resources (Infringements) Regulations 1991 - Extension of Operation) Regulations 2001	A	1-16	\$3.15
		B	17-32	\$4.70
		C	33-48	\$6.45
<i>Authorising Act:</i>	Subordinate Legislation Act 1994	D	49-96	\$10.00
		E	97-144	\$13.00
<i>Date first obtainable:</i>	15 October 2001	F	145-192	\$15.40
<i>Code A</i>		G	193-240	\$17.50
103. Statutory Rule:	Subordinate Legislation (Mineral Resources (Disclosure of Interest) Regulations 1991 - Extension of Operation) Regulations 2001	H	241-288	\$18.90
		I	289-352	\$21.25
		J	353-416	\$24.80
		K	417-480	\$28.35
		L	481-544	\$33.10
		M	545-608	\$37.80
		N	609-672	\$42.55
<i>Authorising Act:</i>	Subordinate Legislation Act 1994	O	673-736	\$47.30
		P	737-800	\$52.00
<i>Date first obtainable:</i>	15 October 2001	<i>*All Prices Include GST</i>		
<i>Code A</i>				
104. Statutory Rule:	Victorian Relief Committee Regulations 2001			
<i>Authorising Act:</i>	Victorian Relief Committee Act 1958			
<i>Date first obtainable:</i>	15 October 2001			
<i>Code A</i>				

ADVERTISERS PLEASE NOTE

As from 18 October 2001

The last Special Gazette was No. 170 dated 17 October 2001

The last Periodical Gazette was No. 1 dated 29 May 2001

CONTENTS

	Page
Estates of Deceased Persons	2624
Government and Outer Budget Sector	
Agencies Notices	2630
Orders in Council	2675
Acts — Administrative Arrangements; BLF (De-recognition); Intellectually Disabled Persons Services; Crown Land (Reserves); Land; Forests; Local Government	
Private Advertisements	2623
Proclamations	2629

The Victoria Government Gazette is published by The Craftsman Press Pty. Ltd. with the authority of the Government Printer for the State of Victoria
© State of Victoria 2001

ISSN 0819-5471

This publication is copyright. No parts may be reproduced by any process except in accordance with the provisions of the Copyright Act.

Products and services advertised in this publication are not endorsed by The Craftsman Press Pty. Ltd. or the State of Victoria and neither of them accepts any responsibility for the content or the quality of reproduction. The Craftsman Press Pty. Ltd. reserves the right to reject any advertising material it considers unsuitable for government publication.

Address all enquiries to the Government Printer for the State of Victoria
Government Information and Communications Branch
Department of Premier and Cabinet
Level 3, 356 Collins Street
Melbourne 3000
Victoria Australia

RETAIL SALES

Information Victoria Bookshop
356 Collins Street Melbourne 3000.
Telephone enquiries 1300 366 356

City Graphics
Level 1, 520 Bourke Street
Melbourne 3000
Telephone enquiries (03) 9600 0977

Recommended Retail Price \$1.85 (includes GST)

Government and Outer Budget Sector Agencies please note:
STYLE REQUIREMENTS.

To ensure that material received can be reproduced, and that errors are minimised, the following guidelines are to be observed when submitting material by fax.

Fax resolution:

Material sent by fax should be transmitted using Fine Resolution (200 dots per inch by 200 dpi).

Font size:

Use 12 point (10 pitch) or larger.

Font Style:

Clear plain font styles, such as Helvetica, should be used.

Graphics:

Line drawings should be transmitted as large as possible to ensure clarity. Drawings up to A4 size sent by fax using Fine Resolution provide a good quality for reproduction.

Avoid:

Italics, underlining and full justification.

Ensure document is square when sending as documents that are sent skewed are difficult to read and process.

ISSN 0819-5471



9 770819 548932