



# Victoria Government Gazette

No. G 12 Thursday 22 March 2001

**GENERAL**

## GENERAL AND PERIODICAL GAZETTE

Copy to: Gazette Officer  
The Craftsman Press Pty. Ltd.  
125 Highbury Road,  
Burwood Vic 3125  
Telephone: (03) 9926 1233  
Facsimile: (03) 9926 1292  
DX: 32510 Burwood  
Email: gazette@craftpress.com.au

### Advertising Rates and Payment

#### Private Notices

Payment must be received in advance with advertisement details.

30 cents per word - Full page \$180.00.

Additional costs must be included in prepayment if a copy of the gazette is required. Copy Prices - Page \$1.50 - Gazette \$3.20 Certified copy of Gazette \$3.50. (all prices include Postage). **Cheques should be made payable to The Craftsman Press Pty. Ltd.**

#### Government and Outer Budget Sector Agencies Notices

Not required to pre-pay.

Advertisements may be faxed or sent via email with a cover sheet, marked to the attention of the Gazette Officer. Floppy Disks (Mac & PC) can also be accepted.

Costs can be calculated on the following basis:

Per Line	Typeset
Single column	\$1.55
Double column	\$3.10
Full Page	\$64.80

The Craftsman Press is pleased to offer a series of discounts from the typesetting costs.

1. Copy supplied on disk.
2. Copy supplied via email.
3. Artwork for forms and other material which require exact reproduction.

#### 1. Copy supplied on disk.

Where a disk is supplied and there is minimum alteration required, **30% off.**

Where a disk is supplied requiring extraneous matter stripped out and styles applied, **20% off.**

#### 2. Copy supplied via email.

Where a notice is sent via email and there is minimum alteration required, **25% off.**

Where email is supplied requiring extraneous matter stripped out and styles applied, **15% off.**

#### 3. Artwork for forms and other material which requires exact reproduction.

Scanning and sizing of artwork for forms, to be reproduced in page format, **35% off.**

#### Copy Deadline for General Gazette

9.30 a.m. Monday - (Private Notices)

9.30 a.m. Tuesday - (Government and Outer Budget Sector Agencies Notices)

### Advertisers should note:

- Late copy received at The Craftsman Press Pty. Ltd. after deadlines will be placed in the following issue of VGG, irrespective of any date/s mentioned in the copy (unless otherwise advised).
- Proofs will be supplied only when requested or at the direction of the Gazette Officer.
- No additions or amendments to material for publications will be accepted by telephone.
- Orders in Council may be lodged prior to receiving assent with the Governor's or Clerk's signature. They will only be published once approved and signed.
- Government and Outer Budget Sector Agencies please note: *See style requirements on back page.*

## SPECIAL GAZETTES

Copy to: Gazette Officer  
The Craftsman Press Pty. Ltd.  
125 Highbury Road,  
Burwood Vic 3125  
Telephone: (03) 9926 1233  
Facsimile: (03) 9926 1292  
Email: gazette@craftpress.com.au

### Advertising Rates and Payment

#### Private Notices

Full Page \$360.00

Payment must be received in advance with notice details.

#### Government and Outer Budget Sector Agencies Notices

	Typeset
Full Page	\$87.50

#### Note:

The after hours number for Special Gazettes is:  
Telephone: 0419 327 321

## SUBSCRIPTIONS AND RETAIL SALES

Copies of the Victoria Government Gazette can be purchased from The Craftsman Press Pty. Ltd. by subscription.

The Victoria Government Gazette

General and Special - \$170.00 each year

General, Special and Periodical - \$227.00 each year

Periodical - \$113.00 each year

Subscriptions are payable in advance and accepted for a period of one year. All subscriptions are on a firm basis and refunds will not be given.

**All payments should be made payable to The Craftsman Press Pty. Ltd.**

### Subscription enquiries:

The Craftsman Press Pty. Ltd.  
125 Highbury Road, Burwood Vic 3125  
Telephone: (03) 9926 1233

## INDEX TO PRIVATE ADVERTISERS

<b>A</b>	
Abbott, Stillman & Wilson . . . . .	.479
Aitken Walker & Strachan . . . . .	.480
Andrew G.J. Rowan . . . . .	.480
<b>B</b>	
Basile & Co. . . . .	.480
Bonella, Cutler & Co . . . . .	.480
<b>C</b>	
Campagna Gray & Mallinder . . . . .	.480
Chessell Williams . . . . .	.480
<b>G</b>	
Garden & Green . . . . .	.481
Gray Friend & Long . . . . .	.481
<b>J</b>	
John Stewart . . . . .	.481
<b>K</b>	
Kelly & Chapman . . . . .	.481
<b>L</b>	
Littleton Hackford . . . . .	.481
<b>M</b>	
McKean & Park . . . . .	.481
M. R. Bell & Associates . . . . .	.482
Mr H. S. Davies . . . . .	.482
Maddock Lonie & Chisholm . . . . .	.482
Mason Sier Turnbull . . . . .	.482
Meer*-kin & Apel . . . . .	.482
Mosley & Palmer . . . . .	.482
<b>O</b>	
O'Brien & Galante . . . . .	.482
<b>P</b>	
Paul McGuinness & Associates Pty . . . . .	.483
<b>R</b>	
Rigby Cooke . . . . .	.483
Roberts Partners . . . . .	.483
Russo Pellicano Carlei . . . . .	.483
<b>S</b>	
Septimus Jones & Lee . . . . .	.484
<b>W</b>	
Wider Moses Bengasino . . . . .	.484
Wills & Probate Victoria . . . . .	.484
Wisewoulds . . . . .	.484

**PRIVATE ADVERTISEMENTS**

**HOMICIDE**  
\$100,000 Reward

The co-operation of the public is sought to establish the identity of the person or persons responsible for the death of Kristy Mary HARTY, who died as a result of injuries she received on or about 17 June 1997.

A reward of up to \$100,000 will be paid at the discretion of the Acting Chief Commissioner of Police, for information leading to the apprehension and subsequent conviction of any person responsible for the death of Kristy Mary HARTY.

Any information, which will be treated as confidential, may be given at any time to Crime Stoppers via telephone number, Toll Free – 1800 333 000, or the Homicide Squad, 412 St Kilda Road, Melbourne on telephone number (03) 9865 2770 during normal business hours.

NEIL O'LOUGHLIN  
Acting Chief Commissioner of Police

**NOTICE SPECIAL RESOLUTIONS**

“The following special resolutions were duly passed at an extraordinary meeting of the members of Co-ordinating Unit for Rural Health Education in Victoria Inc. held on 23 February 2001:

1. That the necessary steps be taken to wind up the Co-ordinating Unit for Rural Health Education in Victoria Inc. (CURHEV);
2. That David Lee be appointed as the liquidator to attend to the liquidation procedure in respect of the winding-up of CURHEV;
3. That David Lee be directed to exercise his authorities and powers by applying the balance of any surplus property, assets or monies held by CURHEV after all obligations under the **Associations Incorporation Act 1981 (Vic)**, debts and liabilities have been met to those entities which will assume the responsibilities of CURHEV once CURHEV has been wound-up, excepting that any assets which are not required by such entities may be disposed of in any manner the Executive Director of CURHEV sees fit”.

**DISSOLUTION OF PARTNERSHIP**

Notice is hereby given that contemporaneous to the admission of the said Christine Suet Yee Mak as partner, Andrew Lau has departed as partner from the firm as from 2 January 2001 and the partnership between Andrew Lau, Shirley Neoh and the newly admitted Christine Suet Yee Mak has been dissolved by mutual consent as from 2 January 2001 so far as concerns Andrew Lau.

The continuing partners being Shirley Neoh and Christine Suet Yee Mak will continue to carry on the said business in partnership under the above business name and style at 149 Kings Road, St. Albans 3021 in the State of Victoria.

Dated 20 February 2001

Authorised by the  
abovenamed continuing partners  
Kings Road Pharmacy

**ADMISSION OF A PARTNER**

Notice is hereby given that Christine Suet Yee Mak has been admitted as from 2 January 2001 as a new partner of the partnership hitherto carried out between Andrew Lau and Shirley Neoh in respect of the retail pharmacy business known as and under the style and name of “Kings Road Pharmacy” situated and located at 149 Kings Road, St. Albans 3021 in the State of Victoria.

Dated 20 February 2001

Authorised by the  
abovenamed continuing partners  
Kings Road Pharmacy

Re: VINCENZO SERAFINI, late of 9 Juniper Crescent, Thomastown, Victoria 3074, transport contractor, deceased. Creditors, next-of-kin and others having claims in respect of the estate of the deceased, who died on 17 December 1999, are required by the administratrix, Angela Lanzetti of 16 Cedar Street, Thomastown, Victoria, married woman, to send particulars to the trustee by 23 May 2001 after which date the administratrix may convey or distribute the assets having regard only to the claims of which the trustee has notice.

ABBOTT, STILLMAN & WILSON, solicitors,  
Level 4, 575 Bourke Street, Melbourne 3000.

AGNES ADELAIDE BURKE, late of 2 Keep Avenue, Rushall Park, Rushall Crescent, North Fitzroy, widow, deceased. Creditors, next-of-kin and others having claims in respect of the estate of the deceased, who died on 8 January 2001, are required by the personal representatives, Rickard Middleton Joseph Burke and Helen Jean Burke, both of 42-44 Hume Lane, Mount Dandenong, to send particulars to them care of the undermentioned solicitors by 30 May 2001 after which date the personal representatives may convey or distribute the assets having regard only to the claims of which they then have notice.

AITKEN WALKER & STRACHAN,  
solicitors  
114 William Street, Melbourne 3000.

---

ELSIE BEATRICE CULLEN, late of Ferntree Gardens Aged Care, 30 Forest Road, Ferntree Gully, widow, deceased. Creditors, next-of-kin and others having claims in respect of the estate of the deceased, who died on 16 December 2000, are required by Equity Trustees Limited, A.C.N. 004 031 298, the proving executor of the will of the deceased, to send particulars of their claims to the executor in the care of the undermentioned solicitor by 22 May 2001 after which date the executor may convey or distribute the assets having regard only to the claims of which it then has notice.

ANDREW G. J. ROWAN, solicitor,  
Level 4, 472 Bourke Street, Melbourne 3000.

---

Re: Estate NITA ETHELINE BOWDEN, deceased. In the estate of NITA ETHELINE BOWDEN of Unit 3, 13 Albert Street, Kerang, in the State of Victoria, widow, deceased. Creditors, next-of-kin and all other persons having claims against the estate of the said deceased, are required by Audrey Rogers of 104 Shadforth Street, Kerang, Victoria, the executrix of the will of the said deceased, to send particulars of such claims to her in care of the undermentioned solicitors within two months from the date of publication of this notice after which date she will distribute the assets having regard only to the claims of which they then have notice.

BASILE & CO. PTY LTD., legal practitioners,  
46 Wellington Street, Kerang, Vic. 3579.

---

KAREN HARREMOES, late of Amahla House, 1019 Glenthuntly Road, Caulfield South, Victoria, gentlewoman, deceased. Creditors, next-of-kin and others having claims in respect of the estate of Karen Harremoes, deceased, who died on 7 March 2000, are required by Pamela Elsa Claverdon-Jones of Unit 68 Atlantis East, 2 Admiralty Drive, Paradise Waters, Queensland, being the personal representative of the said deceased, to send particulars of their claims to her, care of the undermentioned solicitors by 26 May 2001 after which date the personal representative may convey or distribute the assets of the estate of the said deceased, having regard only to the claims of which she then has notice.

BONELLA, CUTLER & CO., solicitors,  
23 Cooper Avenue, Glen Waverley, Victoria 3150.

---

Creditors, next-of-kin and others having claims in respect of the estate of MADELINE CLARA FLANAGAN, late of RMB 1380, Yabba South Road, Dookie, in the State of Victoria, pensioner, deceased, who died on 11 November 2000, are required by the executors to send particulars of their claims to the undermentioned solicitors within two months of this notice after which date the executors will distribute the assets to the persons entitled, having regard only to the claims of which they then had notice.

CAMPAGNA GRAY & MALLINDER,  
solicitors,  
11 Chisholm Street, Wangaratta 3677.

---

Re: PAULINE HEATHER DAVIES. Creditors, next-of-kin and others having claims in respect of the estate of PAULINE HEATHER DAVIES, deceased, late of 20 Winifred Crescent, Toorak, Victoria, who died on 20 June 2000, are requested to send particulars of their claims to the executors care of the undermentioned solicitors by 31 May 2001 after which date they will distribute the assets having regard only to the claims at which date they then had notice.

CHESSELL WILLIAMS, solicitors,  
379 Collins Street, Melbourne 3000.

---

Re: OLIVE ROSE SHIPPEN, late of Bethlehem Home for the Aged, Taylor Street, Golden Square, Victoria, home duties, deceased. Creditors, next-of-kin and others having claims in respect of the estate of the deceased, who died on 13 September 2000, are required by the trustees, John Ellis Shippen and William Keith Shippen, to send particulars to them care of the undermentioned solicitors by 16 May 2001 after which date the trustees may convey or distribute the assets having regard only to the claims of which they have notice.

GARDEN & GREEN, solicitors,  
4 McCallum Street, Swan Hill 3585.

---

KENNETH HEATHCOTE OWEN, late of 4 Murray Court, Trafalgar, retired, deceased. Creditors, next-of-kin and others having claims in respect of the estate of the deceased, who died on 15 November 2000, are required by the trustee, Ruby Isabel Owen, to send particulars to her care of the undersigned solicitors by 22 May 2001 after which date the trustee may convey or distribute the assets having regard only to the claims of which she then has notice.

GRAY FRIEND & LONG, solicitors,  
70 Queen Street, Warragul 3820.

---

Creditors, next-of-kin and others having claims in respect of the will of FLORENCE NELLIE SHELDON, late of 35 Blyth Street, Brunswick, Victoria, spinster, deceased, who died on 27 January 2001, are requested to send particulars of their claims to the executors, Thomas William Sheldon and Sandra Ann Williams, care of the undermentioned legal practitioner by 23 May 2001 after which date they will distribute the assets having regard only as to the claims of which they then have notice.

JOHN STEWART, legal practitioner,  
290 Racecourse Road, Newmarket.

---

Creditors, next-of-kin and others having claims in respect of the estate of TELMA MAY EVANS, late of 5 Seaview Avenue, Bentleigh, deceased, who died on 31 October 2000, are required by the substituted executor nominated in the deceased's last will and testament dated 3 July 1985 namely Stanley Joseph Sandford of 2A Merrilands Road, Reservoir, Victoria, who is applying to the Supreme Court for a grant of

probate of the said last will and testament, the instituted executor, Thomas William Evans, late of 5 Seaview Avenue, Bentleigh, Victoria, having failed to have survived the deceased by one calendar month having died on 23 November 2000, to send particulars of such claims to the solicitors acting for the said executor namely, Kelly & Chapman, 437 Centre Road, Bentleigh by 24 May 2001 after which date the said executor may convey or distribute the assets of the deceased, having regard only to the claims of which he or his solicitors then have notice.

KELLY & CHAPMAN, lawyers,  
437 Centre Road, Bentleigh.

---

Creditors, next-of-kin and others having claims in respect of the estate of VICTOR WILLIAM BRINSMEAD, late of 10 Ash Street, Morwell, Victoria, retired operator, deceased, who died on 13 February 2001, are to send their claims to the trustee, Eva Lavinia Brinsmead of 3 Raywood Avenue, Cowes, Victoria, care of the below mentioned solicitors by 15 May 2001 after which date she will distribute the assets of the deceased having regard only to the claims of which she then has notice.

LITTLETON HACKFORD, solicitors,  
Law Chambers,  
115 Hotham Street, Traralgon, Vic. 3844.

---

JRe: CRAIG ANDREW SMITH, late of 1/49 McKenzie Street West, Golden Square 3555, gardener, deceased. Creditors, next-of-kin and others having claims in respect of the estate of the deceased, who died on 1 January 2001, are required by the trustee, Sandhurst Trustees Limited, A.C.N. 004 030 737 of 18 View Street, Bendigo, Victoria, administrator, to send particulars to the trustee by 21 May 2001 after which date the trustee may convey or distribute the assets having regard only to the claims of which the trustee has notice.

McKEAN & PARK, solicitors,  
405 Little Bourke Street, Melbourne 3000.

---

Creditors, next-of-kin and other persons having claims against the estate of HUGH GRIFFITH FFLOYD CHOMLEY, late of "Cooralya", Sugarloaf Creek, Broadford, Victoria, airline pilot, who died on 8 October 1999, are required by the executor of his estate, Richard Griffith Ffloyd Chomley of "Kalimna"

RMB 1475, via Romsey, Victoria, to send particulars of their claims to him care of the undersigned by 23 May 2001 after which date he may convey or distribute the estate having regard only to the claims of which he then has notice.

M. R. BELL & ASSOCIATES, solicitors,  
376 Victoria Street, North Melbourne.

---

Creditors, next-of-kin and other persons having claims against the estate of GARY KEITH MATTHEWS, late of 33 Fiskin Street, Bacchus Marsh, Victoria, fire fighter, who died on 3 November 2000, are required by the executors of his estate, Vicki Joy Matthews of 33 Fiskin Street, Bacchus Marsh, Victoria and Peter Kenneth Hewett of 28 Waratah Street, Ascot Vale, Victoria, to send particulars of their claims to them care of the undersigned by 23 May 2001 after which date they may convey or distribute the estate having regard only to the claims of which they then have notice.

M. R. BELL & ASSOCIATES, solicitors,  
376 Victoria Street, North Melbourne.

---

NATALINA MAIORANO, late of 7 Kilrush Street, Brighton Beach, home duties, deceased. Creditors, next-of-kin and others having claims in respect of the estate of the deceased, who died at South Caulfield on 13 October 2000, are required to send particulars of their claim to the legal personal representative care of the under mentioned solicitor by 23 May 2001, after which date the legal personal representative may convey or distribute the assets having regard only to the claims of which he then has notice.

Mr H. S. DAVIES, solicitor,  
53 Murray Street, Elsternwick.

---

Re: BERYL RUBY HORTON, late of 40 Queen Street, Ormond, Victoria, spinster, deceased. Creditors, next-of-kin and others having claims in respect of the estate of the deceased, who died on 1 October 2000, are required by the trustees, Ronald Walter Horton of 63 Baker Avenue, Kew, Victoria and Kenneth David Horton of 15 White Street, Glen Iris, Victoria, to send particulars to the trustees by 24 May 2001 after which date the trustees may convey or distribute the assets having regard only to the claims of which the trustees have notice.

MADDOCK LONIE & CHISHOLM solicitors,  
140 William Street, Melbourne 3000.

---

Creditors, next-of-kin and others having claims in respect of the estate of JEAN LYNETTE JORDAN, late of 12 Elm Street, Ripponlea, Victoria, education consultant, deceased, who died on 5 December 2000, are required to send particulars of their claims to the executors care of the undermentioned solicitors by 22 May 2001 after which date the executors will distribute the assets having regard only to the claims of which they then have notice.

MASON SIER TURNBULL, solicitors,  
5 Hamilton Place, Mount Waverley.

---

NELLIE VERA WATSON, late of 23 Fitzroy Street, Bentleigh, Victoria, home duties, deceased. Creditors, next-of-kin and others having claims in respect of the estate of the deceased, who died on 25 October 2000, are required by National Australia Trustees Limited, A.C.N. 007 350 405 of 271 Collins Street, Melbourne, to send particulars of their claims to the said company by 20 May 2001 after which date it will convey or distribute the assets having regard only to the claims of which the company then has notice.

MEERKIN & APEL, solicitors,  
46 Caroline Street, South Yarra, Vic. 3141.

---

Re: EDNA MURIEL MUNDY, late of 41 Boundary Road, Orbost Victoria, home duties. Creditors, next-of-kin and others having claims in respect of the estate of the deceased, who died on 24 January 2001, are required by Malcolm Ernest Mundy of 34 Hamilton Street, Orbost, Victoria and Peter John Mundy of 27 Stirling Street, Orbost, Victoria, the executors appointed in the will, to send particulars to their solicitors within sixty days from the date of publication of this notice after which date the executors may convey or distribute the assets having regard only to the claims of which they then have notice.

MOSLEY & PALMER, solicitors,  
P.O. Box 243, Orbost 3888.

---

ERNEST HENRY CHAMBERS, late of Queens Park Aged Care Hostel, The Strand, Moonee Ponds, retired, deceased. Creditors, next-of-kin and others having claims in respect of the estate of the abovenamed deceased, who died on 8 May 2000, are to send particulars of their claims to the executor, Florence Hildene

Chambers, care of the undermentioned solicitors by 30 May 2001 after which date the said executor will distribute the assets having regard only to the claims of which she then has notice.

O'BRIEN & GALANTE, solicitors  
27 Norwood Crescent, Moonee Ponds.

---

TIMOTHY ALOYSIUS JOSEPH QUINN, late of 2 Walmer Avenue, St. Albans East, Victoria, retired, deceased. Creditors, next-of-kin and others having claims in respect of the estate of the abovenamed deceased, who died on 8 May 1994, are to send particulars of their claims to the administrators, Raymond Alan Quinn and Melva Beryl Milsome, care of the undermentioned solicitors by 30 May 2001 after which date the administrators will distribute the assets having regard only to the claims of which they then have notice.

O'BRIEN & GALANTE, solicitors  
27 Norwood Crescent, Moonee Ponds.

---

DORIS HARRIETT NICOL, late of Unit 2, 117 Boneo Road, Rosebud, Victoria, home duties, deceased. Creditors, next-of-kin and others having claims in respect of the estate of the deceased, who died on 2 December 2000, are required to send particulars of their claims to the trustee care of the undermentioned solicitors by 15 May 2001 after which date the trustee or personal representative or applicant for grant of administration may convey or distribute the assets having regard only to the claims of which he then has notice.

PAUL McGUINNESS & ASSOCIATES PTY, solicitors,  
3 Eighth Avenue, Rosebud 3939.  
Tel. (03) 5986 6999.

---

Creditors, next-of-kin or others having claims in respect of the estate of KEVIN TRUSWELL LEWIS, late of Unit 5, 20 Tintern Avenue, Toorak, company director, deceased, who died on 3 December 2000, are to send particulars of their claims to the executor care of the undermentioned solicitors by 24 May 2001 after which date the executor will distribute the assets having regard only to the claims of which the executor then has notice.

RIGBY COOKE, solicitors,  
469 La Trobe Street, Melbourne 3000.

---

Re: GERARD JOHN DOUBE, late of 135 Beach Road, Sandringham, retired, deceased. Creditors, next-of-kin or others having claims in respect of the estate of the deceased, who died on 5 February 2001, are required by the trustee, John Christopher Doube of 23 Channel Street, Mornington, Victoria, self employed, to send particulars to the trustee by 23 May 2001 after which date the trustee may convey or distribute the assets having regard only to the claims of which the trustee then has notice.

ROBERTS PARTNERS,  
216 Main Street, Mornington.

---

Re: PAUL POLLAK, late of 374 Nepean Highway, Frankston, but formerly of 2 Mount Eliza Way, Mount Eliza, retired, deceased. Creditors, next-of-kin or others having claims in respect of the estate of the deceased, who died on 15 October 2000, are required by the trustees, Andy Loizou, painter and decorator and Bronwen Meredith Loizou, hairdresser, both of 25 Luxton Terrace, Seaford, Victoria, to send particulars to the trustees by 23 May 2001 after which date the trustees may convey or distribute the assets having regard only to the claims of which the trustees then have notice.

ROBERTS PARTNERS,  
216 Main Street, Mornington.

---

Re: MICHAEL LEO CORBOY, late of 31 Endeavour Avenue, Lilli Pilli, New South Wales, audit inspector, deceased. Creditors, next-of-kin and others having claims in respect of the estate of the deceased, who died between 22 and 23 October 2000, are required by the trustees, Roger Azzopardi of 20 Montrose Street, Montmorency, Victoria, brother-in-law and Bruno Dinelli of 16 Ranleigh Rise, Lower Templestowe, Victoria, friend, to send particulars to the trustees by 31 May 2001 after which date the trustees may convey or distribute the assets having regard only to the claims of which the trustees have notice.

RUSSO PELLICANO CARLEI, solicitors,  
43 Atherton Road, Oakleigh 3166.

---

Re: HELEN KATHLEEN BOWEN, late of Alexandra Private Nursing Home, 304 Hawthorn Road, Caulfield South, Victoria, widow, deceased. Creditors, next-of-kin and others having claims in respect of the estate of the

deceased, who died on 11 September 2000, are required by the trustees, to send particulars to the trustees no later than two months after the publication of this notice hereof and after which date the trustees may convey or distribute the assets having regard only to the claims of which the trustees have notice.

SEPTIMUS JONES & LEE, solicitors,  
Level 5, 99 William Street, Melbourne 3000.

---

Creditors, next-of-kin and others having claims against the estate of DONALD ARTHUR PEGRUM, late of 14 Third Avenue, Aspendale, Victoria, retired, deceased, who died on 15 November 2000, are required to send particulars of their claims to the executor, George Robert Paterson c/- the undermentioned solicitors by 22 May 2001 after which date the executor will distribute the assets having regard only to the claims of which he then has notice.

WILDER MOSES BENGASINO, lawyers,  
8/233 Cardigan Street, Carlton 3053.

---

Re: ENA LEMMON. Creditors, next-of-kin and others having claims in respect of the estate of ENA LEMMON, deceased, late of 7 Mair Street, Brighton, who died on 2 September 2000, are required to send particulars of their claims to the executors C/- Wills & Probate Victoria, GPO Box 1946R, Melbourne 3001 by 1 June 2001 after which date the executors may convey or distribute the assets having regard only to the claims of which they may then have notice.

WILLS & PROBATE VICTORIA, lawyers,  
Level 5, 360 Little Bourke Street, Melbourne.

---

Re: ANDREW JOHN MIDDLETON. Creditors, next-of-kin and others having claims in respect of the estate of ANDREW JOHN MIDDLETON, the deceased, who died on 8 October 2000, are required to send particulars of their claims to the executor C/- Wills & Probate Victoria, GPO Box 1946R, Melbourne 3001 by 25 May 2001 after which date the executor may convey or distribute the assets having regard only to the claims of which he may then have notice.

WILLS & PROBATE VICTORIA, lawyers,  
Level 5, 360 Little Bourke Street, Melbourne.

---

Re: VALENTINE ESMA McNALLY. Creditors, next-of-kin and others having claims in respect of the estate of VALENTINE ESMA McNALLY, the deceased, who died on 7 July 2001, are required to send particulars of their claims to the executors C/- Wills & Probate Victoria, GPO Box 1946R, Melbourne 3001 by 1 June 2001 after which date the executors may convey or distribute the assets having regard only to the claims of which they may then have notice.

WILLS & PROBATE VICTORIA, lawyers,  
Level 5, 360 Little Bourke Street, Melbourne.

---

GWENDOLEN NORAH BURBIDGE, formerly of Unit 40, Pinetree Village, 330 Springvale Road, Donvale, but late of Vaucluse Hospital, 82 Moreland Road, Brunswick, Victoria, retired nurse, deceased. Creditors, next-of-kin and others having claims in respect of the estate of the abovenamed deceased, who died on 9 July 2000, are required by the executors, Andrew Malcolm Burbidge of 9 Laverton Street, Williamstown, Victoria and Richard John Burbidge of 19 Conway Avenue, Rose Bay, New South Wales, to send particulars to the executors by 5 July 2001 after which date the executors intend to convey or distribute the assets of the estate having regard only to the claims of which the executors may have notice.

WISEWOULDS, solicitors,  
459 Collins Street, Melbourne.

---



**PROCLAMATIONS**

**Gambling Legislation (Miscellaneous  
Amendments) Act 2000**

PROCLAMATION OF COMMENCEMENT

I, Marigold Southey, Lieutenant-Governor of Victoria, as the Governor's deputy, with the advice of the Executive Council and under section 2(2) of the **Gambling Legislation (Miscellaneous Amendments) Act 2000**, fix 22 March 2001 as the day on which section 30 of that Act comes into operation.

Given under my hand and the seal of  
Victoria on 20 March 2001

L.S.           MARIGOLD SOUTHEY  
Lieutenant-Governor,  
as the Governor's deputy  
By His Excellency's Command

JOHN PANDAZOPOULOS  
Minister for Gaming

---

**Heritage (Amendment) Act 2000**

PROCLAMATION OF COMMENCEMENT

I, Marigold Southey, Lieutenant-Governor of Victoria, as the Governor's deputy, with the advice of the Executive Council and under section 2(1) of the **Heritage (Amendment) Act 2000**, fix 1 April 2001 as the day on which that Act comes into operation.

Given under my hand and the seal of  
Victoria on 20 March 2001

(L.S.)           MARIGOLD SOUTHEY  
Lieutenant-Governor,  
as the Governor's deputy  
By His Excellency's Command

JOHN THWAITES  
Minister for Planning

---

**GOVERNMENT AND OUTER BUDGET SECTOR AGENCIES  
NOTICES**



**ROAD DISCONTINUANCE**

At its meeting on 21 February 2001 and acting under clause 3 of schedule 10 to the **Local Government Act 1989** Glen Eira City Council resolved to discontinue the road shown hatched on the plan below.

The road is to be sold subject to any right, power or interest held by South East Water in the road in connection with any sewers, drains or pipes under the control of that authority in or near the road.

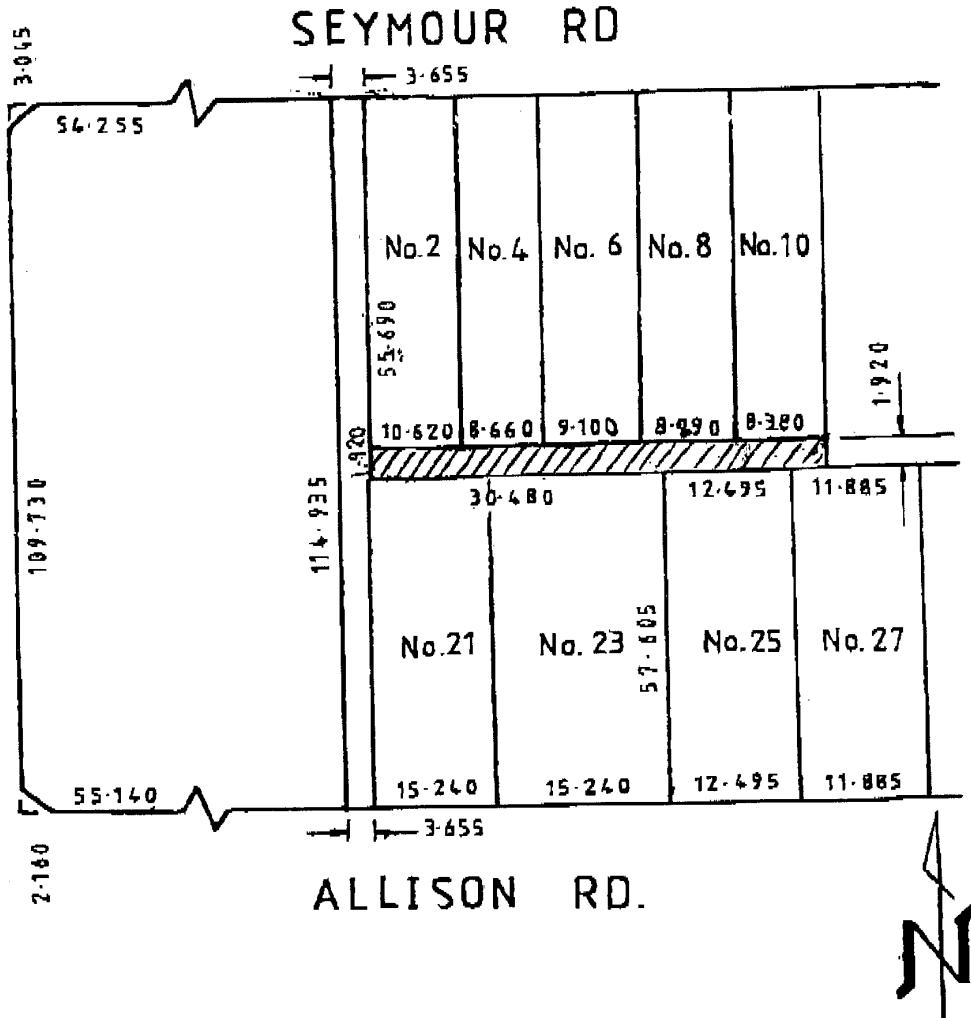

Mr ANDREW NEWTON  
Chief Executive Officer



GLEN EIRA CITY COUNCIL  
Road Discontinuance

Pursuant to section 206 and schedule 10, clause 3 of the **Local Government Act 1989**, the Glen Eira City Council, formed the opinion that the road in Egan Street, Carnegie, shown by hatching on the plan below, is not reasonably required as a road for public use and resolved to discontinue the road and to sell the land from the road by Private Treaty to the abutting property owner.

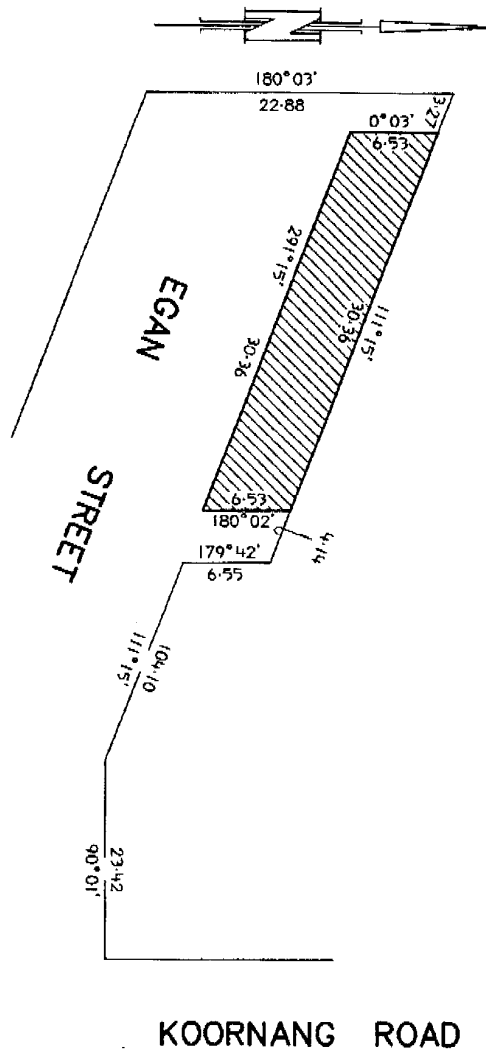

ANDREW NEWTON  
Chief Executive Officer

LATROBE CITY COUNCIL  
Proposed Road Deviation and Discontinuance

Notice is hereby given that, in accordance with the provisions of Clause 2 of Schedule 10 of the **Local Government Act 1989**, Latrobe City Council, having obtained consent of the Minister administering the **Land Act 1989**, hereby deviates the road shown hatched through the land described in Certificates of Title Volume 8173, Folio 117, Volume 8984, Folio 330 and Volume 8984, Folio 331 and discontinues the land shown cross-hatched and gives notice that once vested in the Council pursuant to Section 207B of the Act such land will be transferred to the owner of the land through which the road is to be deviated.

PLAN FOR ROAD EXCHANGE  
CROWN ALLOTMENTS 9, 9 A & 9 D  
SECTION A  
PARISH OF YINNAR

SCALE 1:2000

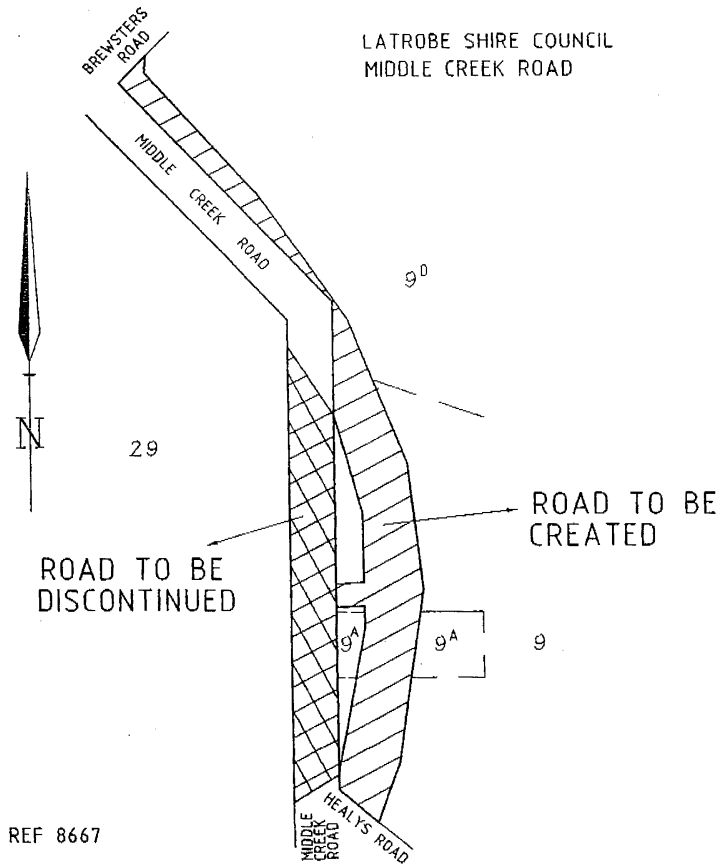

PENNY HOLLOWAY  
Chief Executive Officer

LATROBE CITY COUNCIL  
Road Discontinuance –  
Part Hillcrest Court, Traralgon

Pursuant to the provisions of section 206 and Schedule 10, Clause 3 of the **Local Government Act 1989**, the Latrobe City Council at its Ordinary meeting held on 5 March 2001, formed the opinion that the unmade sections of Hillcrest Court adjoining lots 186, 187, 192 & 193 LP145387, being the road shown hatched on the plan below, is not reasonably required as a road for public use and resolved to discontinue the section of road and sell the land by private treaty, subject to any right, power or interest held by any authority or utility in respect to any sewers, drains, pipes, wires or cable under the control of the authority or utility.

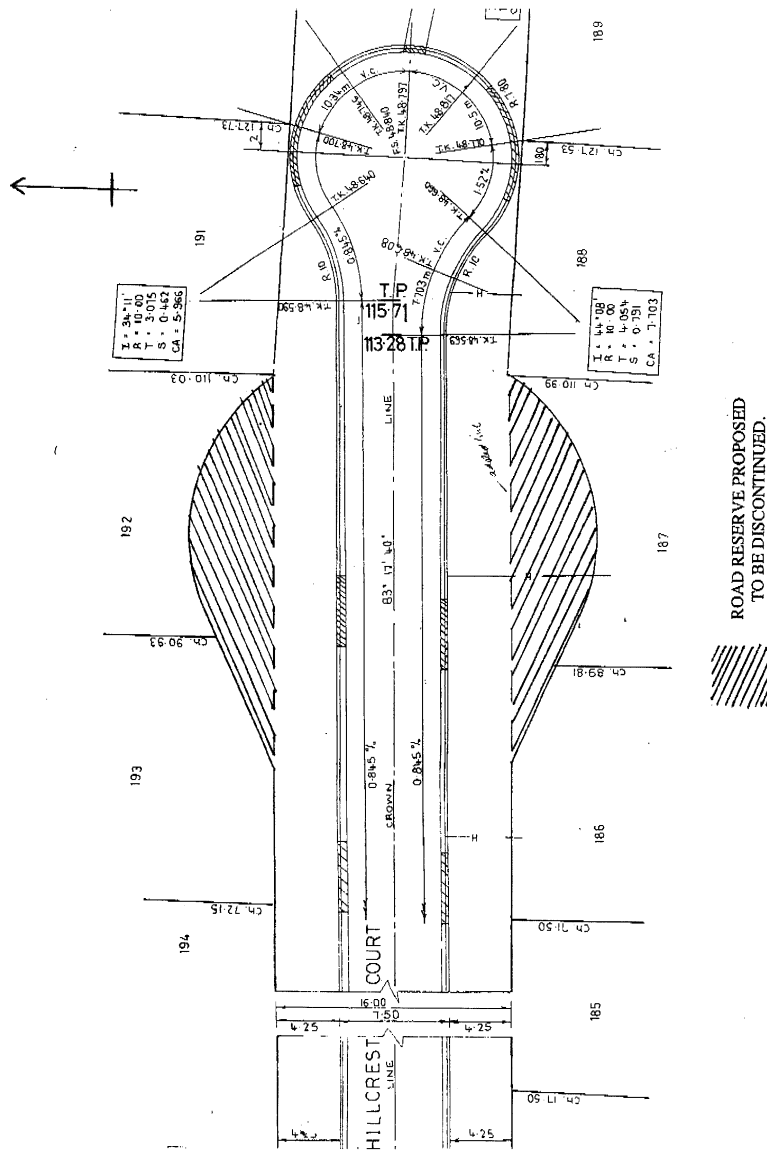

PENNY HOLLOWAY  
Chief Executive Officer

LATROBE CITY COUNCIL

Road Deviation –  
Mays Road, Glengarry

Pursuant to the provisions of Section 206 and Clause 2 of Schedule 10 of the **Local Government Act 1989**, Latrobe City Council at its meeting on 5 March 2001, resolved to deviate Mays Road, Glengarry as shown on the plan below and that the land from the road be exchanged by private treaty with the abutting owner.

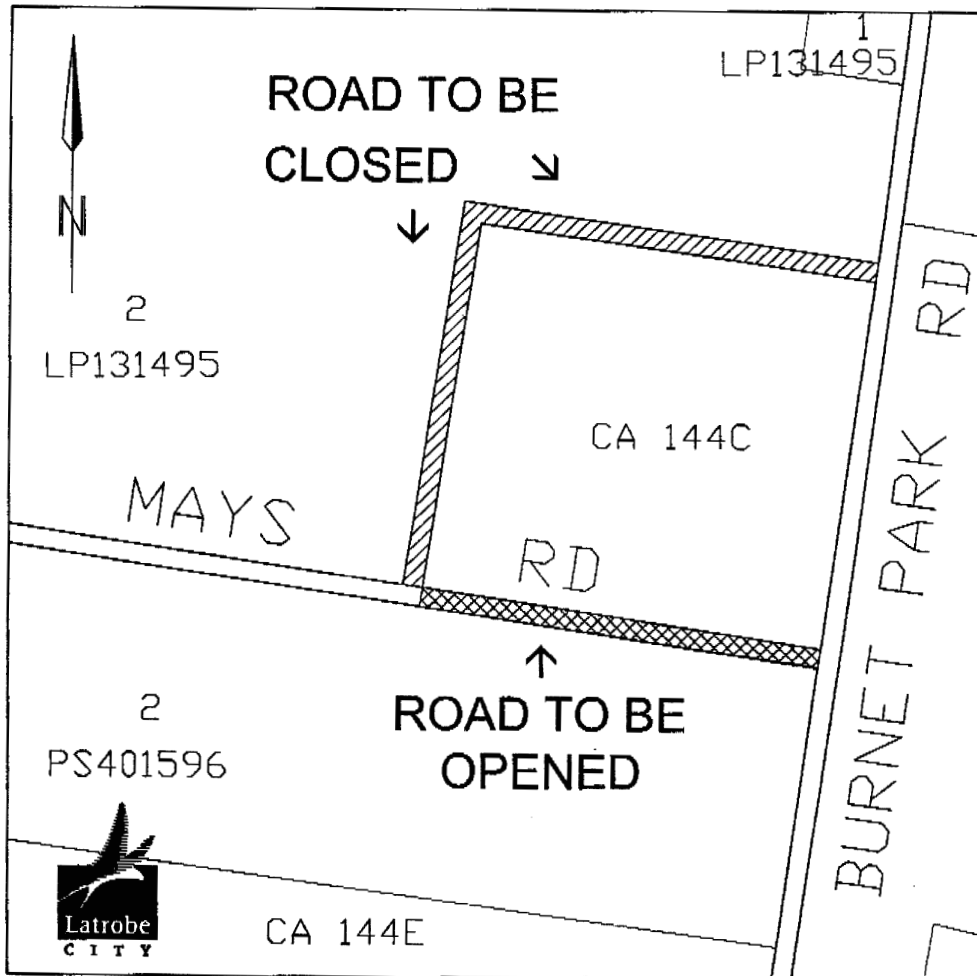

PENNY HOLLOWAY  
Chief Executive Officer

MURRINDINDI SHIRE COUNCIL

Road Deviation

Banbury Road, Murrindindi

Pursuant to Section 207B and Clause 2 of Schedule 10 and Section 207E of the **Local Government Act 1989**, Murrindindi Shire Council at its ordinary meeting held on 20 February 2001, resolved to deviate Banbury Road as set out in the plan below by closing the portion of the road shown cross hatched and opening the portion of the road shown hatched, and pursuant to

Section 204(1) of the **Local Government Act 1989** declares the portion of road shown hatched on the plan below to be a public highway.

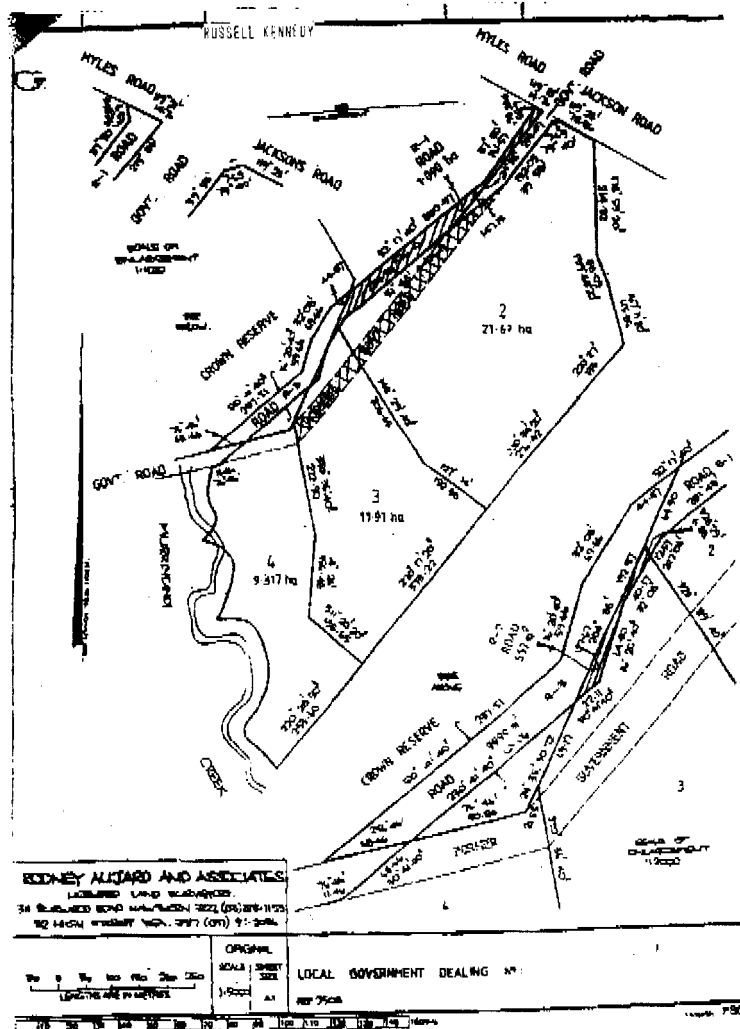

**DAREBIN CITY COUNCIL**  
Road Discontinuance

Pursuant to section 206 and schedule 10, clause 3 of the **Local Government Act 1989**, the Darebin City Council at its ordinary meeting held on 2 October 2000, formed the opinion that the road at the rear of 8 to 26 McMahon Road and 1 to 11 Crookston Road, Reservoir, and shown hatched on the plan below is not reasonably required as a road for public use and resolved to discontinue the road and to sell the land from the road by private treaty to the abutting property owners.

The road is to be sold subject to the right, power or interest held by Yarra Valley Water Limited in the road in connection with any sewers, drains or pipes under the control of that authority in or near the road.

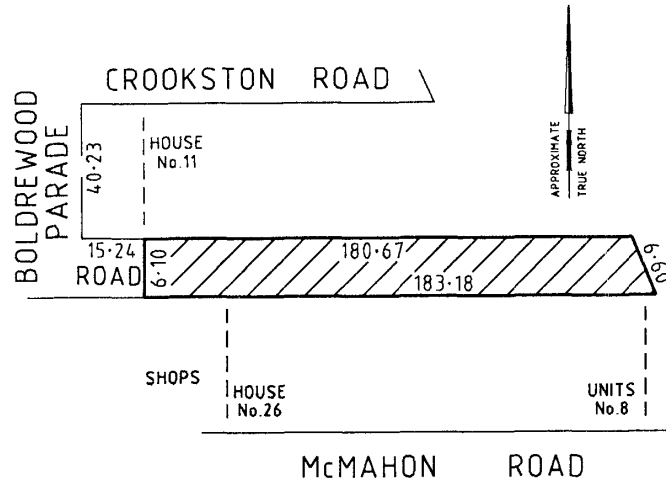

PHILLIP SHANAHAN  
Chief Executive Officer

DAREBIN CITY COUNCIL  
Road Discontinuance

Pursuant to section 206 and schedule 10, clause 3 of the **Local Government Act 1989**, the Darebin City Council at its ordinary meeting held on 5 March, 2001, formed the opinion that the road at the rear of 148 to 152 Cramer Street, 40 to 60 James Street, 501 to 509 Murray Road and 21 to 41 Grandview Road, Preston, and shown by hatching and cross-hatching on the plan below, is not reasonably required as a road for public use and resolved to discontinue the road and to sell the land from the road by private treaty to the abutting property owners.

The cross-hatched section of the road is to be sold subject to the right, power or interest held by Yarra Valley Water Limited, in the road in connection with any sewers, drains or pipes under the control of that authority in or near the road.

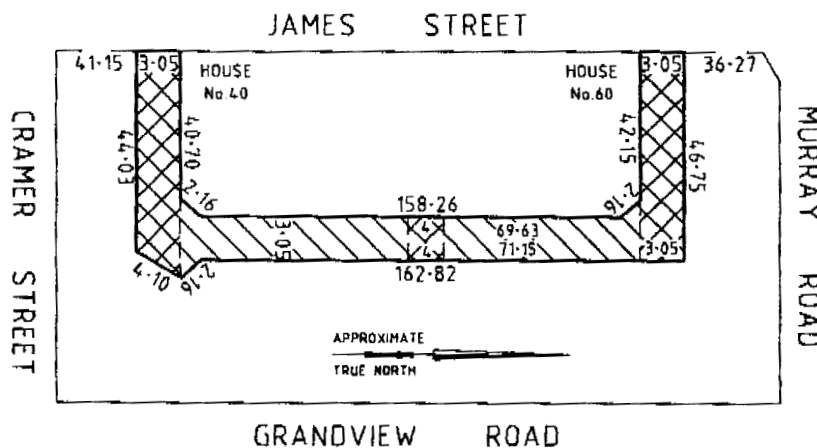

PHILLIP SHANAHAN  
Chief Executive Officer





CITY OF  
BALLARAT

**Local Government Act 1989**

SECTION 206 CLAUSE 3 SCHEDULE 10

Ballarat City Council

Discontinuance of Part of Road

Ballarat City Council hereby gives notice that it has discontinued that part of Shepherd Street, Ballarat shown hatched on the plan hereunder.

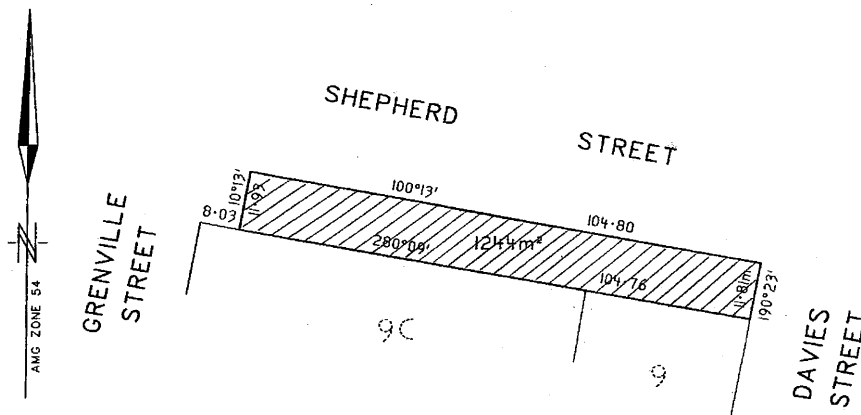

JOHN McLEAN  
Chief Executive Officer

LATROBE CITY COUNCIL

**Public Holidays Act 1993**

Notice is hereby given that the Latrobe City Council pursuant to Section 7 of the **Public Holidays Act 1993** appoints Thursday 18 October 2001 as a half-day Public Holiday. This public holiday from 12 noon is for that part of the municipality within the declared town and rural districts of Moe, Newborough, Yallourn, Moe South, Hernes Oak, Tanjil South and Yallourn North. The purpose of this holiday is in recognition of the Moe Cup Race meeting.

PENNY HOLLOWAY  
Chief Executive Officer

MOIRA SHIRE COUNCIL

**Public Holidays Act 1993**

Moirra Shire Council in accordance with Section 7(1)(b) of the **Public Holidays Act 1993**, has declared a half day public holiday from 12 noon for the Numurkah district on Wednesday 24 October 2001 for the Numurkah Show Day.

Further, in accordance with Section 9 (a) of the **Public Holidays Act 1993** a half day bank holiday will apply for the Numurkah district from 12 noon on Wednesday 24 October 2001.

Residents are advised that the Municipal office at Numurkah will operate as normal on this day.

GAVIN CATOR  
Chief Executive Officer



MILDURA RURAL CITY COUNCIL  
ROAD DISCONTINUANCE/  
EXCHANGE OF LAND

Under Section 206 and Schedule 10, Clause 3 of the **Local Government Act 1989** the Mildura Rural City Council discontinues that part of Seventeenth Street and Koorlong Avenue shown hatched on the plan hereunder and exchanges it for part of the land shown cross hatched on the plan.

Council has also formed the opinion that the road shown shaded on the plan is not reasonably required as a road for public use and has resolved to discontinue the road and to sell the land to the adjoining owner. The land shown hatched and shaded is a section of Government Road and the Minister for Environment and Conservation has given consent to the proposed road deviation and exchange.

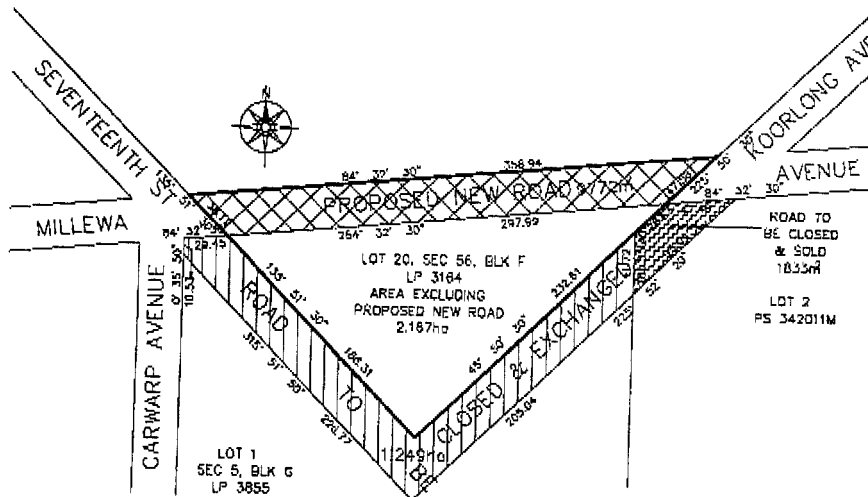

LEONIE BURROWS  
Chief Executive Officer



AMENDMENT TO LOCAL LAW NO. 3

Notice is hereby given that at its meeting held on 5 March 2001, Council resolved to adopt an amendment to Local Law No. 3 pursuant to the provisions of the **Local Government Act 1989**.

The purpose and purport of the amendments are to provide for the protection and preservation of the natural environment of Lake Tom Thumb and its environs. Lake Tom Thumb is designated as an Environmental Conservation Zone and the conservation and rehabilitation of the natural assets of this site is the preliminary objective. Council resolved to amend Local Law No. 3 as follows:

1. Add to clause 2 (objectives of this Local Law) a sub-clause (e):  
'(e) To provide for the protection and preservation of the natural environment of Lake Tom Thumb and its environs.'

2. Substitute clause 19 with the following:  
 '19. Protection and preservation of Lake Tom Thumb and its environs
- (a) A person shall not within the proclaimed area No. 1 to this local law drive, use or operate a motorcycle or a remote controlled boat, plane or car.
- (b) A plan showing the proclaimed area No. 1 is attached to this local law.'
3. Clause 19 shall become clause 20.

A copy of the local law can be obtained from Council Offices at Lyttleton Terrace, Bendigo.

ANDREW PAUL  
 Chief Executive Officer



LOCAL LAW NO. 3 – ROADS, STREETS  
 AND PUBLIC PLACES

Notice is hereby given that on 23 January 2001 Campaspe Shire Council resolved to commence proceedings to amend Local Law No. 3 entitled Roads, Streets and Public Places Local Law.

The purpose of the amendment is:–

- To control the use of roller blades, scooters and skateboards in areas frequented by the public.
- To improve the procedures for dealing with abandoned vehicles.
- To reduce vandalism of Council property.
- To control noise and busking on roads and public places.
- To comply with the national competition policy by removing exemptions previously given to public authorities that allowed them to occupy a road for works without a Council permit.

Any person may inspect a copy of the proposed amendment from any Shire of Campaspe office or Customer Service Centre.

Any person affected by the proposed amendment may make written submission to Council. To be considered, a submission must

reach Council within 21 days of the publication of this notice.

Submissions will be considered in accordance with Section 223 of the **Local Government Act 1989**.

Any person who makes a submission may request in writing that he or she be heard in person or by a person acting on his or her behalf.

All submissions should be addressed to: The Chief Executive Officer, Shire of Campaspe, PO Box 35, Echuca, Vic. 3564.

PHIL PEARCE  
 Chief Executive Officer

**Planning and Environment Act 1987**  
**MORELAND PLANNING SCHEME**  
 Notice of Amendment

Amendment C10

Moreland City Council has prepared Amendment C10 to the Moreland Planning Scheme.

The Amendment affects land at:

- 42 David Street, Brunswick;
- 839 Park Street, Brunswick;
- 42 Ross Street, Coburg;
- 828 Sydney Road, Brunswick;
- Outbuildings to the rear of 38 Harrison Street, Brunswick (currently HO90);
- 48 Harrison Street, Brunswick;
- 13–15 Rosser Street, Brunswick;
- 14–24 Rosser Street, Brunswick.

The Amendment proposes to include each of the properties at 42 David Street, Brunswick (remove interim status); 839 Park Street, Brunswick; 42 Ross Street, Coburg; 13–15 Rosser Street, Brunswick; 14–24 Rosser Street, Brunswick and 828 Sydney Road, Brunswick within the Moreland Planning Scheme Heritage Overlay. It will also alter the schedule to HO90 to include the three outbuildings to the rear of 38 Harrison Street, Brunswick. The amendment also corrects a mapping anomaly that placed HO90 on 48 Harrison Street, Brunswick which is now demolished.

A copy of the Amendment can be inspected, free of charge, during office hours, at the Department of Infrastructure, Customer Service Centre, Upper Plaza, Nauru House, 80 Collins

Street, Melbourne or the offices of the Moreland City Council, 90 Bell Street, Coburg.

Submissions in writing on the Amendment are welcomed. Submissions must be received by 24 April 2001 and be addressed to: Moreland City Council, Attention: Geoff Bellamy, City Strategy Department, Locked Bag 10, Moreland, Vic. 3058.

ADRIAN ROBB  
Director City Strategy

**Planning and Environment Act 1987**  
MORELAND PLANNING SCHEME

Notice of Amendment  
Amendment C12

Moreland City Council has prepared Amendment C12 to the Moreland Planning Scheme.

The Amendment changes the Local Provisions of the Moreland Planning Scheme.

The Amendment affects land within the Public Acquisition Overlay 1 in the vicinity of:

- Leonard Street and the Merri Creek, Fawkner;
- Lorne Street and the Merri Creek, Fawkner;
- Queens Parade, Fawkner across the Merri Creek to Newlands Road, Coburg.

The propose of the rezoning is to remove the Public Acquisition Overlay from land identified for Merri Creek Crossings as part of the Fawkner section of the F2 Freeway alignment.

The Amendment can be inspected, free of charge, during office hours, at: Moreland City Council, Municipal Offices, 90 Bell Street, Coburg, Vic. 3058 and Department of Infrastructure, Customer Service Centre, Upper Plaza, Nauru House, 80 Collins Street, Melbourne, Vic. 3000.

Submissions on the Amendment are welcome and should be received in writing at the Council Offices by close of business on 24 April 2001. Submissions should be sent to: Miss Julie Hallyburton, Team Leader – Strategic Land Use Planning, Moreland City Council, Locked Bag 10, Moreland, Vic. 3058.

ADRIAN ROBB  
Director City Strategy

**Planning and Environment Act 1987**

LATROBE PLANNING SCHEME

Notice of Amendment

Amendment C6

Latrobe City Council has prepared Amendment C6 to the Latrobe Planning Scheme.

The Amendment proposes to rezone land at Commercial Road, Morwell being land held in Crown Grants Volume 9903, Folio 227 and Volume 9904, Folio 210 from Public Use Zone – transport (PUZ4) to the Business 2 Zone (B2Z).

A copy of the Amendment can be inspected at: Latrobe City Council, municipal offices – Kay Street, Traralgon; Hazelwood Road, Morwell; and Albert Street, Moe; Regional Office of the Department of Infrastructure – 120 Kay Street, Traralgon and Department of Infrastructure, Information Services Division, 80 Collins Street, Melbourne.

Inspection of the Amendment will be free of charge to any person during office hours.

Any submission you may wish to make in respect of the Amendment must be in writing and sent to the Chief Executive Officer, Latrobe City Council, PO Box 345, Traralgon 3844 by Friday 20 April 2001.

If you have any questions regarding the Amendment please contact Elaine Wood, Land Use Planning Leader on (03) 5173 1444.

PENNY HOLLOWAY  
Chief Executive Officer

**Planning and Environment Act 1987**  
STRATHBOGIE PLANNING SCHEME

Notice of Amendment

Amendment C5

Strathbogrie Shire Council has prepared Amendment C5 to the Strathbogrie Planning Scheme.

The land affected by the Amendment is: All land within a 1.5km radius of the Drysdale Road piggery and mushroom composting facility (CA 10, Section 4, Parish of Branjee, Drysdale Road, Euroa) (see Sheet 1). All land within a 500 metre radius of the Eatmore poultry breeding complex (CA's 28A, 28B, 29A, 29B, 29A1 and 30AB, Nagambie Locksley Road, Nagambie) (see

Sheet 2). All land within a 200 metre radius of the Violet Town Landfill (McDiarmid Road, Violet Town), as shown on Strathbogie Planning Scheme Map No. 6ESO.

The Amendment proposes to: Include all land within a 1.5km radius of the Drysdale Road piggery and mushroom composting facility (Drysdale Road, Euroa) within an Environmental Significance Overlay (ESO1 – Buffer Area for Rural Industrial Activities). Include all land within a 500 metre radius of the Eatmore poultry breeding complex (Nagambie Locksley Road, Nagambie) within an Environmental Significance Overlay (ESO1 – Buffer Area for Rural Industrial Activities). Amend Schedule 1 to the Environmental Significance Overlay to include a revised statement of environmental significance, an additional objective and amended decision guidelines.

The Amendment, explanatory report and associated documents can be inspected free of charge during office hours at:– Department of Infrastructure, Customer Service Centre, Upper Plaza, Nauru House, 80 Collins Street, Melbourne; Department of Infrastructure, North Eastern Region, 50–52 Clarke Street, Benalla; Strathbogie Shire Council, Corner Binney and Bury Streets, Euroa; Strathbogie Shire Council, Corner High and Vale Streets, Nagambie.

Submissions in writing about the Amendment must be sent to the Chief Executive Officer, Strathbogie Shire Council, PO Box 17, Euroa 3666 by 19 April 2001.

---

**Planning and Environment Act 1987**  
STRATHBOGIE PLANNING SCHEME  
Notice of Amendment  
Amendment C9

Strathbogie Shire Council has prepared Amendment C9 to the Strathbogie Planning Scheme.

The land affected by the Amendment is: All land within a 2.2km radius of the Chiquita mushroom composting facility (CA 1, Section B, Parish of Monea North, Ballantynes Road, Nagambie) (see Sheet 1).

The Amendment proposes to: Include all land within 2.2km radius of the Chiquita

mushroom composting facility (Ballantynes Road, Nagambie) within an Environmental Significance Overlay (ESO1 – Buffer Area for Rural Industrial Activities).

The Amendment, explanatory report and associated documents can be inspected free of charge during office hours at:– Department of Infrastructure, Customer Service Centre, Upper Plaza, Nauru House, 80 Collins Street, Melbourne; Department of Infrastructure, North Eastern Region, 50–52 Clarke Street, Benalla; Strathbogie Shire Council, Corner Binney and Bury Streets, Euroa; Strathbogie Shire Council, Corner High and Vale Streets, Nagambie.

Submissions in writing about the Amendment must be sent to the Chief Executive Officer, Strathbogie Shire Council, PO Box 17, Euroa 3666 by 19 April 2001.

---

**Planning and Environment Act 1987**  
CARDINIA PLANNING SCHEME  
Notice of Amendment  
Amendment C2

The Cardinia Shire Council has prepared Amendment C2 to the Cardinia Planning Scheme.

The Amendment affects land described as: Land in Beaconsfield bounded by O'Neil Road to the west, the Princes Highway to the south and May Road to the east, known as Part Crown Allotment 34, Parish of Pakenham.

The Amendment proposes to: Rezone the land from a Rural zone to a Residential 1 zone and Public Use zone 6 (Local Government) to allow the land to be developed for urban residential purposes including a site for the proposed Beaconsfield community centre. Delete the Environmental Significance Overlay (Schedule 1) currently applying to the land. Include the land in a Development Plan overlay (Schedule 2).

The Amendment can be inspected at: Cardinia Shire Council, Municipal Office, Henty Way, Pakenham and Department of Infrastructure, Customer Service Centre, Upper Plaza, Nauru House, 80 Collins Street, Melbourne.

Any person who is affected by the Amendment may make a submission in writing

about the Amendment. Submissions must be sent to: Philip Walton, Manager Planning, Building and Environment, Cardinia Shire Council, P.O. Box 7, Pakenham 3810 by 23 April 2001.

---

**Planning and Environment Act 1987**

**KNOX PLANNING SCHEME**

Notice of Amendment

Amendment C22

Knox City Council has prepared an Amendment which proposes to amend the Local Section of the Knox Planning Scheme, as follows: Amend the Municipal Strategic Statement to introduce the concept of the production economy, define the proposed Scoresby/Rowville Employment Precinct and reflect introduction of the new local planning policy. Introduce a new local planning policy entitled 'Scoresby/Rowville Employment Precinct' at Clause 22.08. Rezone Industrial 1 zoned land bounded by Ferntree Gully, Stud and Wellington Roads and the Scoresby Freeway Reservation (except land at 966 Stud Road, Rowville) to the Business 3 Zone to allow a broader range of production economy related uses. Rezone part of Caribbean Lake and adjoining land forming part of Caribbean Gardens from Special Use Zone Schedule 1 and Public Park and Recreation Zone, partly to the Business 3 Zone and partly to the Urban Floodway Zone to protect the critical flood catchment area identified by Melbourne Water and allow for landscaping and recreation uses and development at the Lake edge. Rectify map errors arising from the introduction of the new format planning scheme by rezoning the Rowville Greenhouse Garden Centre site at 1060 Stud Road, Rowville and land forming part of Caribbean Gardens to the Business 3 Zone to form part of the proposed Employment Precinct. Place Development Plan Overlay Schedule 6 over Caribbean Gardens and Caribbean Industrial Estate, to require approval of a development plan for the site before any applications for use and development are considered. Place a Land Subject to Inundation Overlay over land within the proposed Employment Precinct identified by Melbourne Water as being flood-prone.

The Amendment can be inspected at: Knox City Council, City Development Customer Service Counter, Civic Centre, Ground Floor Entrance, 511 Burwood Highway, Wantirna

South 3152 and Department of Infrastructure, Planning Information Centre, Plaza Level 3 at Nauru House, 80 Collins Street, Melbourne 3000.

Any persons affected by the Amendment may make a submission in writing, which must be sent to Justin O'Meara, Strategic Planner, Knox City Council, Locked Bag 1, Wantirna South 3152 by 20 April 2001.

JOHN KNAGGS  
Group Manager –  
City Development

---

Creditors, next of kin and others having claims against the estate of any of the undermentioned deceased persons are required to send particulars of their claims to State Trustees Limited, A.C.N 064 593 148, 168 Exhibition Street, Melbourne, Victoria 3000, the personal representative, on or before 22 May 2001 after which date State Trustees Limited may convey or distribute the assets having regard only to the claims of which State Trustees Limited then has notice.

ASPELING, Gertrude Bridget, also known as Gertrude Bridgette Aspelng, late of 16 Morcom Avenue, Ringwood East, home duties, who died 21 January 2001.

CAIN, Keith Kitchener, late of Keith House Nursing Home, Armadale Street, Armadale, pensioner, who died 25 February 2001.

COLLINS, Jean Campbell, also known as Jean Mary Collins, late of Lake Park Nursing Home, 1 Lake Road, Blackburn, retired, who died 19 January 2001.

JARVIE, James Alexander, formerly of 34 Middleton Street, Highett, but late of Room 117 Grace Thomson House, 7 Centre Road, Brighton East, retired, who died 30 November 2000.

MOREHOUSE, Elizabeth Julia, late of Toora Nursing Home, Welshpool Road, Toora, retired, who died 12 October 2000.

PEERLESS, Erci Frank, late of 7 South Street, Urangan, Queensland, retired builder, who died 15 June 2000.

SINFIELD, Ellen Patricia, late of Sorrento Lodge, 211 Ocean Road, Sorrento, retired, who died 7 November 2000.

Dated at Melbourne, 13 March 2001

CATHY VANDERFEEN  
Manager, Estate Management  
State Trustees Limited

---

Creditors, next of kin and others having claims against the estate of any of the undermentioned deceased persons are required to send particulars of their claims to State Trustees Limited, A.C.N 064 593 148, 168 Exhibition Street, Melbourne, Victoria 3000, the personal representative, on or before 25 April 2001 after which date State Trustees Limited may convey or distribute the assets having regard only to the claims of which State Trustees Limited then has notice.

COLEMAN, Thomas Francis, late of 15 Boronia Street, Bentleigh East, pensioner, who died 5 December 2000.

ELLISON, James Edward, late of 48 Howitt Street, South Yarra, retired, who died 14 December 2000.

HUXTABLE, Doris Thelma, formerly of 5/1 Garden Avenue Glenhuntly, but late of McKinnon Private Nursing Home, 97 Wheatley Street, McKinnon, retired, who died 1 February 2001.

LEONARD, Jack Raymond, late of 10 Glenburn Road, Lower Plenty, retired, who died 30 November 2000.

LILYWHITE, Thelma Anne, late of Hanslope Private Nursing Home, 12 Hanslope Avenue, Alphington, gentlewoman, who died 17 November 2000

LYNAS, George Kennedy, late of 33 Jordan Street, Ashwood, retired, who died 9 December 2000.

McKAY, Mabel Gertrude, formerly of Flat 6, "Cornwell", 2 Grandview Grove, Prahran East, but late of Harcourt – Special Accommodation, 300 High Street, Windsor, widow, who died 24 December 2000.

MOLARO, Leonie Mary, late of Unit 1, 13 Grey Street, Balwyn, gentlewoman, who died 25 October 2000.

NORTON, Doris Vere, late of Lovell House, 389 Alma Road, Caulfield North, gentlewoman, who died 7 December 2000.

PARSONS, Archibald, late of Central Park Nursing Home, K15 Raleigh Street, Windsor, retired, who died 18 January 2001.

PEARCE, Alda Esibel, late of 44 Rona Street, Reservoir, pensioner, who died 30 January 2000.

THOMPSON, Sydney Arthur, formerly of 40 Afton Street, Essendon, but late of Ashleigh Lodge, Cochrane Street, Brighton, retired, who died 21 October 2000.

THORNELLY, Kathleen Gwendoline, late of 59 Kinsale Street, Reservoir, home duties, who died 17 November 2000

WARE, Martha Edith, late of Unit 2, 1 Miller Court, Hoppers Crossing, housewife, who died 9 December 2000.

Dated at Melbourne, 14 March 2001

CATHY VANDERFEEN  
Manager, Estate Management  
State Trustees Limited

#### EXEMPTION

Application No. A78 of 2001

The Victorian Civil and Administrative Tribunal has considered an application pursuant to Section 83 of the **Equal Opportunity Act 1995**, by the Victorian Aboriginal Community Controlled Health Organisation for exemption from Sections 13, 100 and 195 of that Act. The application for exemption is to ensure that Aboriginal and Torres Strait Islander people only can enrol in the Certificate IV in Indigenous Women's and Babies Health course, except under special circumstances where it has been noted that non-indigenous people may be considered subject to the approval of the course co-ordinator.

Upon reading the material submitted in support of the application the Tribunal is satisfied that it is appropriate to grant the exemption from Sections 13, 100 and 195 of the Act.

In granting this exemption, the Tribunal noted:

- The application is to assist in the expansion of the indigenous workforce in Victoria.
- The application aims to increase the participation of Aboriginal and Torres Strait Islander people in the education system by giving preference to Aboriginal and Torres Strait Islander people.
- The application focuses on enhancing training for Aboriginal and Torres Strait Islander health workers.
- Many Koori women find hospital based antenatal care intimidating.
- The course is designed to fulfil the training needs for Aboriginal and Torres Strait Islander people.

The Tribunal hereby grants an exemption to the applicant from the operation of Sections 13, 100 and 195 of the **Equal Opportunity Act 1995** to ensure that Aboriginal and Torres Strait

Islander people only can enrol in the Certificate IV in Indigenous Women's and Babies Health course, except under special circumstances where it has been noted that non-indigenous people may be considered subject to the approval of the course co-ordinator.

This exemption is to remain in force from the day on which notice of the exemption is published in the Government Gazette until 21 March 2004.

Dated 19 March 2001

Mrs A. COGHLAN  
Deputy President

Department of Treasury and Finance

SALE OF CROWN LAND  
BY PUBLIC AUCTION

**Reference:** 97/00930.

**Date of Auction:** Thursday 26 April 2001 at 3.00 p.m. on site.

**Address of Property:** Bellerine Street, Geelong South.

**Crown Description:** Crown Allotment 1, Section 17A, Parish of Corio.

**Terms of Sale:** 10% Deposit, Balance 60 days.

**Area:** 5864 m<sup>2</sup>.

**Officer Co-ordinating Sale:** Kathryn Wylie, Project Manager – Victorian Government Property Group, Department of Treasury and Finance, Level 5, 1 Treasury Place, Melbourne.

**Selling Agent:** Maxwell Collins Pty Ltd, 227 Moorabool Street, Geelong 3220, Victoria.

LYNNE KOSKY MP  
Minister for Finance

**Country Fire Authority Act 1958**

VARIATION OF FIRE DANGER PERIOD

In pursuance of the powers conferred by Section 4 of the **Country Fire Authority Act 1958**, I, Robert Gordon Seiffert, Chief Executive Officer of the Country Fire Authority, after consultation with the Secretary of Natural Resources and Environment, hereby vary the declaration of Fire Danger Periods previously published in the Government Gazette by declaring that such Fire Danger Periods shall end in respect of the undermentioned Municipal

Districts of Municipalities or parts of Municipalities specified.

To terminate from 01.00 hours on 26 March 2001:

Hindmarsh Shire Council (part):– That part north of the netting fence.

Yarriambiack Shire Council (Northern):– That part north of the netting fence.

Campaspe Shire Council.

Loddon Shire Council (Northern):– That part north of a line commencing on the western boundary of the shire travelling easterly along the Borung–Charlton Road to Borung, then along the Borung–Hurstwood Road to the Loddon River, then generally southerly along the Loddon River to the Bridgewater–Serpentine Road, then along Foleys Road to the Loddon Valley Highway, then northerly to Rothackers Road, then continue east along Rothackers Road and Tandarra–Serpentine Road, then south along Thompsons Road then east along Tandarra–Elmore Road and Steads Road to the Shire's eastern boundary.

R. SEIFFERT  
Chief Executive Officer

**Transport Act 1983**

TOW TRUCK DIRECTORATE OF  
VICTORIA

Tow Truck Applications

Notice is hereby given that the following application will be considered by the Licensing Authority after 25 April 2001.

Notice of any objection to the granting of an application should be forwarded to reach the Director, Tow Truck Directorate of Victoria, Level 6, 14–20 Blackwood Street, North Melbourne (PO Box 666, North Melbourne 3051) not later than 19 April 2001.

It will not be necessary for interested parties to appear on the date specified, unless advised in writing.

A & J Morphett (Nominees) Pty Ltd. Application for variation of conditions of tow truck licence number TOW075 which authorises the licensed vehicle to be managed, controlled and operated from a depot situated at 149 Tyabb Road, Mornington to change the depot address to 20 Brasser Avenue, Dromana.

Dated 22 March 2001

STEVE STANKO  
Director



**Crown Land (Reserves) Act 1978**

**ORDER GIVING APPROVAL TO GRANT OF A LEASE UNDER SECTIONS 17D AND 17DA**

Under sections 17D and 17DA of the **Crown Land (Reserves) Act 1978**, I, Sherryl Garbutt, Minister for Environment and Conservation, being satisfied that there are special reasons which make the granting of a lease reasonable and appropriate in the particular circumstances and to do this will not be substantially detrimental to the use and enjoyment of any adjacent land reserved under the **Crown Land (Reserves) Act 1978**, approve the granting of a lease by the Hindmarsh Shire Council for 21 years over the area of Crown land described in the Schedule below and, in accordance with section 17D(3)(a) of the **Crown Land (Reserves) Act 1978**, state that –

- (a) there are special reasons which make granting the lease reasonable and appropriate in the particular circumstances; and
- (b) to do this will not be substantially detrimental to the use and enjoyment of any adjacent land reserved under the **Crown Land (Reserves) Act 1978**.

**SCHEDULE**

The land shown by hatching on the attached plan, being the whole of the area known as the Dimboola Caravan Park being land temporarily reserved for Public Gardens in the Township of Dimboola, Parish of Dimboola, by Order in Council of 7 February 1881 published in the Government Gazette 11 February 1881 page 482.

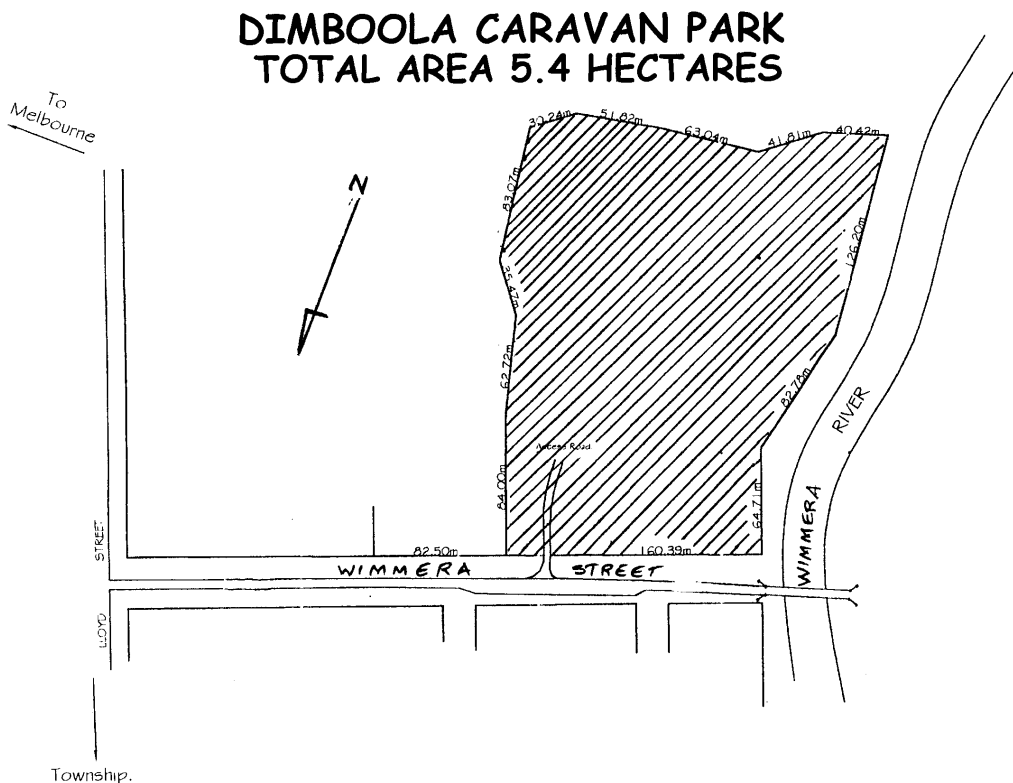

Dated 3 March 2001

SHERRYL GARBUTT MP  
Minister for Environment  
and Conservation

**Crown Land (Reserves) Act 1978**

**ORDER GIVING APPROVAL TO GRANT OF A LEASE UNDER SECTIONS 17D AND 17DA**

Under sections 17D and 17DA of the **Crown Land (Reserves) Act 1978**, I, Sherryl Garbutt, Minister for Environment and Conservation, being satisfied that there are special reasons which make the granting of a lease reasonable and appropriate in the particular circumstances and to do this will not be substantially detrimental to the use and enjoyment of any adjacent land reserved under the **Crown Land (Reserves) Act 1978**, approve the granting of a lease by the Hindmarsh Shire Council for 21 years over the area of Crown land described in the Schedule below and, in accordance with section 17D(3)(a) of the **Crown Land (Reserves) Act 1978**, state that –

- (a) there are special reasons which make granting the lease reasonable and appropriate in the particular circumstances; and
- (b) to do this will not be substantially detrimental to the use and enjoyment of any adjacent land reserved under the **Crown Land (Reserves) Act 1978**.

**SCHEDULE**

The land shown by hatching on the attached plan, being the whole of the area known as the Nhill Caravan Park being land temporarily reserved for Public Park in the Township of Nhill, Parish of Balrootan, by Order in Council of 19 January 1971 published in the Government Gazette 27 January 1971 page 225.

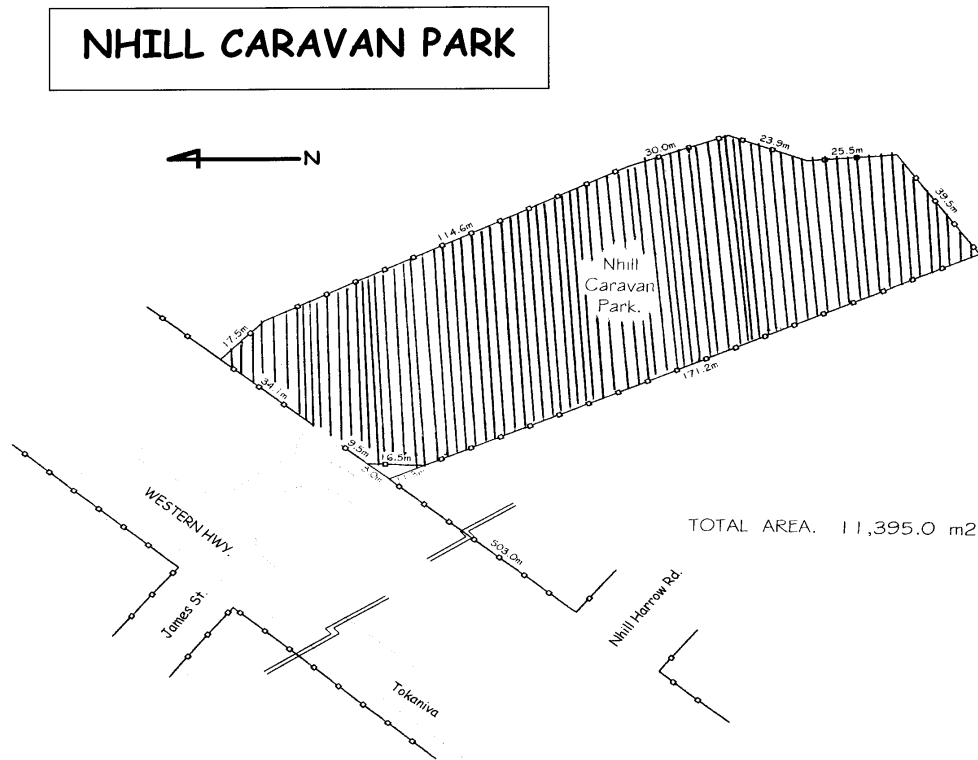

Dated 4 March 2001

SHERRYL GARBUTT MP  
Minister for Environment  
and Conservation

**Associations Incorporation Act 1981**

Notice is hereby given that in pursuance of sub-section 10(4) of the **Associations Incorporation Act 1981** a Certificate of Incorporation was granted to Western District Car Club Inc. on 19 March 2001.

W. NEW  
Deputy Registrar  
of Incorporated Associations

---

**Stamps Act 1958**

NOTICE UNDER SECTION 40A

Pursuant to section 40A of the **Stamps Act 1958** I hereby declare and make effective from 9 March 2001, that:

**AP 408 – Australian Probate Estate & Asset Related Services**

to be no longer an “authorised person” in relation to the stamping of transfers of land, mortgages, bonds, debentures and covenants, marketable securities, leases, agreements to lease, assignments or transfers to lease and instruments of settlement.

DAVID POLLARD  
Commissioner of State Revenue

---

**Water Act 1989**

NOTIFICATION OF PROPOSED  
EXTENSION TO THE NUMURKAH  
WATER DISTRICT

Notice is hereby given that Goulburn Valley Region Water Authority, pursuant to Section 96 of the **Water Act 1989**, has prepared a proposal for the extension of the existing water district boundary at Numurkah.

Areas included in the proposal are in the general vicinity of:

1. Goulburn Valley Highway area (between Nathalia Road & Nathalia-Katamatite Road), and
2. Ashley Court & Brooke Court area.

Full details of the proposal and a copy of the plan showing the proposed district extension are available for inspection, free of charge, at the Authority’s office located at 104–110 Fryers Street, Shepparton, or the Moira Shire Council’s Office located at Melville Street, Numurkah (during normal office hours).

Members of the public are invited to make a written submission to the Authority on the proposal. Any submission must set out the grounds for any objection to the proposal. Submissions should be addressed to: Chief Executive, Goulburn Valley Region Water Authority, P O Box 185, Shepparton 3630.

The Authority must receive any submission by Thursday 23 April 2001, which is one (1) month after the publication of this notice in the Government Gazette.

The Authority will consider any submission received at a Board Meeting following this date.

---

**Planning and Environment Act 1987**

BAW BAW PLANNING SCHEME

Notice of Approval of Amendment

Amendment C2

The Minister for Planning has approved Amendment C2 to the Baw Baw Planning Scheme.

The Amendment comes into operation on the date this notice is published in the Government Gazette.

The Amendment

- 1) Substitutes Local Planning Policy 22.05 by amending and renaming subclause 22.05-3 to Walhalla tourist development area with a requirement that the responsible authority must consider the “Walhalla Township Design and Development Guidelines – July 1999” in deciding on an application to use or develop land.
- 2) Incorporates the “Walhalla Township Design and Development Guidelines – July 1999” as an incorporated document in Clause 81.

A copy of the Amendment can be inspected, free of charge, during office hours, at the Department of Infrastructure, Customer Service Centre, Upper Plaza, Nauru House, 80 Collins Street, Melbourne and at the offices of the Baw Baw Shire Council, Civic Place, Warragul.

PAUL JEROME  
Executive Director  
Planning, Heritage and  
Building Division  
Department of Infrastructure

---

**Planning and Environment Act 1987**  
COLAC OTWAY PLANNING SCHEME  
Notice of Approval of Amendment  
Amendment C7

The Minister for Planning has approved Amendment C7 to the Colac Otway Planning Scheme.

The Amendment comes into operation on the date this notice is published in the Government Gazette.

The Amendment alters the planning scheme maps and the schedule to the Heritage Overlay to identify a number of places included on the Victorian Heritage Register.

A copy of the Amendment can be inspected, free of charge, during office hours, at the Department of Infrastructure, Planning Information Centre, Upper Plaza, Nauru House, 80 Collins Street, Melbourne and at the offices of the Glenelg Shire Council, Customer Service Centre, Bannockburn.

PAUL JEROME  
Executive Director  
Planning, Heritage and  
Building Division  
Department of Infrastructure

---

**Planning and Environment Act 1987**  
MACEDON RANGES PLANNING SCHEME  
Notice of Approval of Amendment  
Amendment C1

The Minister for Planning has approved Amendment C1 to the Macedon Ranges Planning Scheme.

The Amendment comes into operation on the date this notice is published in the Government Gazette.

The Amendment rezones a thin strip of land from Rural Living to Special Use Zone 3 to enable the Kyneton Golf Club to subdivide and acquire the land, which it currently leases as part of its golf course.

A copy of the Amendment can be inspected, free of charge, during office hours, at the Department of Infrastructure, Planning Information Centre, Upper Plaza, Nauru House,

80 Collins Street, Melbourne and at the offices of the Macedon Ranges Shire Council, 129 Mollison Street, Kyneton.

PAUL JEROME  
Executive Director  
Planning, Heritage and  
Building Division  
Department of Infrastructure

---

**Planning and Environment Act 1987**  
SWAN HILL PLANNING SCHEME  
Notice of Approval of Amendment  
Amendment C1

The Minister for Planning has approved Amendment C1 to the Swan Hill Planning Scheme.

The Amendment comes into operation on the date this notice is published in the Government Gazette.

The Amendment establishes a Business 4 Zone along Sea Lake–Swan Hill Road to accommodate bulky goods retailing and manufacturing activities, introduces a new Design and Development Overlay, Schedule 3, on land affected by the Business 4 Zone, rezones the western section of the site to a Residential 1 Zone, rezones several portions of the site to a Public Park and Recreation Zone, extends the boundaries of a Public Use Zone, Service and Utility, alters the boundaries of the Development Plan Overlay, Schedule 1 and revises the table in Local Planning Policy 22.20.

A copy of the Amendment can be inspected, free of charge, during office hours, at the Department of Infrastructure, Customer Service Centre, Upper Plaza, Nauru House, 80 Collins Street, Melbourne; the Department of Infrastructure, Northern Region, 57 Lansell Street, Bendigo and at the offices of the Swan Hill Rural City Council, 45 Splatt Street, Swan Hill.

PAUL JEROME  
Executive Director  
Planning, Heritage and  
Building Division  
Department of Infrastructure

---

**ORDERS IN COUNCIL**

ELIZABETH THE SECOND BY THE GRACE OF GOD  
QUEEN OF AUSTRALIA AND HER OTHER REALMS AND TERRITORIES,  
QUEEN, HEAD OF THE COMMONWEALTH

To: Lex Lasry QC

GREETINGS:

WHEREAS:

- A. By Letters Patent in Our Name by the Governor of the State of Victoria in the Commonwealth of Australia, by and with the Executive Council and acting pursuant to s.88B of the **Constitution Act 1975** on 21 December 1999 and which was recorded in the Register of Patents Book No 42, Page No. 50 on that day, you were appointed and constituted to be Our Commissioner to inquire into and report upon the matters referred to in the Letters Patent by 5 July 2000 or such later date as WE may be pleased to fix.
- B. Those Letters Patent were amended by Letters Patent which were recorded in the Register of Patents Book No. 42, Page No. 53 on 16 May 2000, amended by Letters Patent which were recorded in the Register of Patents Book No. 42, Page No. 56 on 30 May 2000 and further amended by Letters Patent which were recorded in the Register of Patents Book No. 42, Page 63 on 3 October 2000.
- C. It is expedient to fix a later reporting date.

NOW THEREFORE the Governor of the State of Victoria, in the Commonwealth of Australia by and with the advice of the Executive Council and acting pursuant to s.88B of the **Constitution Act 1975** hereby:

- 1 Amends the said Letters Patent by fixing 30 July 2001 as the date upon which you are directed to furnish US with a report of the results of your inquiry and of your recommendations.

IN TESTIMONY WHEREOF WE have caused these Our Letters to be made Patent and the Seal of our State to be hereunder affixed.

WITNESS, Lady Marigold Southey AM, as the Governor's Deputy, Lieutenant-Governor of Victoria and its dependencies in the Commonwealth of Australia at Melbourne this 20th day of March, two thousand and one, in the forty-eighth year of Our reign.

L.S.

MARIGOLD SOUTHEY  
Lieutenant-Governor  
As the Governor's Deputy  
By His Excellency's Command  
STEVE BRACKS  
Premier

Entered on the record by me in the Register of Patents Book No. 42, Page No. 89, on the 20th day of March 2001.

GARTH LAMPE  
Acting Secretary, Department of Premier and Cabinet

---

**Public Lotteries Act 2000**DECLARATION OF A PARTICIPATING  
JURISDICTION AND CORRESPONDING  
LAW

## Order in Council

The Lieutenant-Governor, as the Governor's deputy, with the advice of the Executive Council, under section 59(1) of the **Public Lotteries Act 2000**, declares –

- (a) the Australian Capital Territory to be a participating jurisdiction for the purposes of the **Public Lotteries Act 2000**; and
- (b) the **Pool Betting Act 1964** (A.C.T.) to be a corresponding law for the purposes of the **Public Lotteries Act 2000**.

Dated 20 March 2001

Responsible Minister  
JOHN PANDAZOPOULOS  
Minister for Gaming

HELEN DOYE  
Clerk of the Executive Council

**Parliamentary Committees Act 1968**REFERRAL OF MATTER TO THE  
ENVIRONMENT AND NATURAL  
RESOURCES COMMITTEE OF  
PARLIAMENT

## Order in Council

The Lieutenant Governor as the Governor's deputy with the advice of the Executive Council, under section 4F of the **Parliamentary Committees Act 1968**, refers to the Environment and Natural Resources Committee of Parliament for inquiry, consideration and report to the Parliament, the following matter relating to the adequacy and effectiveness of existing veterinary pathology services to:

- (i) assess the current and future requirements of the Victorian livestock industries, government and veterinarians for veterinary pathology services;
- (ii) assess the adequacy and effectiveness of current veterinary pathology services (within the Department of Natural Resources and Environment and externally) to support the Department's animal health programs and to meet the needs of the Victorian livestock industries;

- (iii) make recommendations on the effective arrangements for provision of veterinary pathology services to meet the future needs of the Victorian livestock industries;

- (iv) report by 31 October 2001.

Dated 20 March 2001

Responsible Minister:  
STEVE BRACKS MP  
Premier

HELEN DOYE  
Clerk of the Executive Council

**Local Government Act 1989**ALTERATION OF WARD BOUNDARIES OF  
HOBSONS BAY CITY COUNCIL

## Order in Council

The Governor in Council hereby directs that:

- a) Under Section 220S (1)(a) of the **Local Government Act 1989**, this Order comes into operation on the day it is published in the Government Gazette; and
- b) Under Section 220Q (k) and (m) of the **Local Government Act 1989**, on the day this Order comes into operation the boundaries of the wards and names of the wards of the Hobsons Bay City Council shall be fixed as described in the Schedule to this Order.

Dated 20 March 2001

Responsible Minister  
BOB CAMERON MP  
Minister for Local Government

HELEN DOYE  
Clerk of the Executive Council

**SCHEDULE****Boundaries of the Wards of  
Hobsons Bay City Council****Altered and Redefined****Boundaries of Blackshaw Ward**

Commencing on the south-eastern boundary of the City at Kororoit Creek; thence north-westerly by Kororoit Creek to a point in line with Maddox Road; thence northerly by a line and Maddox Road to the Melbourne – Geelong Railway; thence easterly and north-easterly by that railway to Melbourne Road; thence northerly by that road to The Avenue; thence easterly by that avenue to Hope

Street; thence southerly by that street to Hudsons Road; thence easterly by that road to Bernard Street; thence southerly by that street to Craig Street; thence westerly by that street to Hall Street; thence southerly by that street to High Street; thence easterly by that street and a line in continuation to the Yarra River being a point on the eastern boundary of the city; thence northerly and generally westerly by the City boundary to Kyle Road; thence further westerly by the West Gate Freeway to Grieve Parade; thence southerly by that parade to Blackshaws Road; thence south-easterly and easterly by that road to Millers Road; thence southerly by that road to the Melbourne – Geelong Railway; thence easterly by that railway to the junction with the Melbourne–Altona Railway; thence southerly by that railway to Kororoit Creek Road; thence easterly by that road to Racecourse Road; thence southerly by that road and further southerly by Altona Road to the south-western boundary of P. A. Burns Reserve; thence south-easterly by that boundary to the south-eastern boundary of the City, and thence north-easterly by the city boundary to the point of commencement.

#### **Boundaries of Wedge Ward**

Commencing on the shore of Port Phillip Bay at a point in line with the northern boundary of allotment 1C, section 5, Parish of Truganina; thence westerly by a line, the northern boundary of that allotment to Queen Street; thence further westerly by that street to the western boundary of the Koorringal Golf Club; thence northerly by that boundary to the southern boundary of the Truganina Swamp; thence generally north-easterly by the south-eastern boundaries of that swamp and the Mt. St. Joseph Wetlands to the junction of Civic Parade with Galvin Street; thence north-westerly by Galvin Street to Park Parade; thence south-westerly by that parade and a line in continuation to a point in line with Aberdeen Road; thence north-westerly by a line and Aberdeen Road to Slough Road; thence north-easterly by that road to Maidstone Street; thence north-westerly by that street to the Melbourne–Geelong Railway; thence north-easterly by that railway to the western boundary of Reserve No. 1 on Plan of Subdivision 424169; thence generally northerly by the western boundary of that reserve to a point in line with The Gateway; thence westerly

by a line and The Gateway to Grieve Parade; thence northerly by that parade to Pinnacle Road; thence westerly by that road to the western boundary of land on Consolidated Plan 156608; thence southerly by that boundary and further southerly by the Dow Tree Plantation to Kororoit Creek Road; thence westerly by that road to the western boundary of Lot 1 on Plan of Subdivision 135215; thence southerly by the western boundary of that lot to the Melbourne–Geelong Railway; thence south-westerly by that railway to the Princes Freeway; thence south-westerly by that freeway to the western boundary of the City and thence westerly, southerly, easterly, northerly, south-easterly and north-easterly by the city boundary to the point of commencement.

#### **Boundaries of Langhorne Ward**

Commencing on the shore of Port Phillip Bay at a point in line with the northern boundary of allotment 1C, section 5, Parish of Truganina; thence westerly by a line, the northern boundary of that allotment to Queen Street; thence further westerly by that street to the western boundary of Koorringal Golf Club; thence northerly by that boundary to the southern boundary of the Truganina Swamp; thence generally north-easterly by the south-eastern boundaries of that swamp and the Mt. St. Joseph Wetlands to the junction of Civic Parade with Galvin Street; thence north-westerly by Galvin Street to Park Parade; thence south-westerly by that parade and a line in continuation to a point in line with Aberdeen Road; thence north-westerly by a line and Aberdeen Road to Slough Road; thence north-easterly by that road to Maidstone Street; thence north-westerly by that street to the Melbourne–Geelong Railway; thence north-easterly by that railway to the western boundary of Reserve No. 1 on Plan of Subdivision 424169; thence generally northerly by the western boundary of that reserve to a point in line with The Gateway; thence westerly by a line and The Gateway to Grieve Parade; thence northerly by that parade to Pinnacle Road; thence westerly by that road to the western boundary of land on Consolidated Plan 156608; thence southerly by that boundary and further southerly by the Dow Tree Plantation of Kororoit Creek Road; thence westerly by that road to the western boundary of Lot 1 on Plan of Subdivision 135215; thence southerly by the

western boundary of that lot to the Melbourne–Geelong Railway; thence south-westerly by that railway to the Princes Freeway; thence south-westerly by that freeway to the western boundary of the City; thence generally northerly, north-easterly and southerly by the city boundary to West Gate Freeway; thence westerly by the West Gate Freeway to Grieve Parade; thence southerly by that parade to Blackshaws Road; thence south-easterly and easterly by that road to Millers Road; thence southerly by that road to the Melbourne–Geelong Railway; thence easterly by that railway to the junction with the Melbourne–Altona Railway; thence southerly by that railway to Kororoit Creek Road; thence easterly by that road to Racecourse Road; thence southerly by that road and further southerly by Altona Road to the south-western boundary of P. A. Burns Reserve; thence south-easterly by that boundary to the south-eastern boundary of the City, and thence south-westerly by the city boundary to the point of commencement.

**Boundaries of Hall Ward**

Commencing on the south-eastern boundary of the City at Kororoit Creek; thence north-westerly by Kororoit Creek to a point in line with Maddox Road; thence northerly by a line and Maddox Road to the Melbourne–Geelong Railway; thence easterly and north-easterly by that railway to Melbourne Road; thence northerly by that road to The Avenue; thence easterly by that avenue to Hope Street; thence southerly by that street to Hudsons Road; thence easterly by that road to Bernard Street; thence southerly by that street to Craig Street; thence westerly by that street to Hall Street; thence southerly by that street to High Street; thence easterly by that street and a line in continuation to the Yarra River being a point on the eastern boundary of the City, and thence generally south-easterly, south-westerly and north-westerly by the city boundary to the point of commencement.

---





**SUBORDINATE LEGISLATION ACT 1994  
NOTICE OF MAKING OF STATUTORY  
RULES**

Notice is hereby given under Section 17 (2) of the **Subordinate Legislation Act 1994** of the making of the following Statutory Rules:

22. *Statutory Rule:* Water (Subdivisional Easements and Reserves) Regulations 2001  
*Authorising Act:* Water Act 1989  
*Date of making:* 20 March 2001
23. *Statutory Rule:* Heritage (Liturgical Purposes Form) Regulations 2001  
*Authorising Act:* Heritage Act 1995  
*Date of making:* 20 March 2001

**SUBORDINATE LEGISLATION ACT 1994  
NOTICE THAT STATUTORY RULES ARE  
OBTAINABLE**

Notice is hereby given under Section 17 (3) of the **Subordinate Legislation Act 1994** that the following Statutory Rules were first obtainable from Information Victoria, 356 Collins Street, Melbourne on the date specified:

20. *Statutory Rule:* Fisheries (Fees and Levies) Regulations 2001  
*Authorising Act:* Fisheries Act 1995  
*Date first obtainable:* 22 March 2001  
*Code A*
21. *Statutory Rule:* Accident Compensation Regulations 2001  
*Authorising Act:* Accident Compensation Act 1985  
 Accident Compensation (WorkCover Insurance) Act 1993  
*Date first obtainable:* 22 March 2001  
*Code C*

Retail price will vary according to the number of pages in each special or periodical gazette. The table below sets out the prices that apply

<i>Price Code</i>	<i>No. of Pages (Including cover and blank pages)</i>	<i>Price</i>
A	1-16	\$2.90
B	17-32	\$4.30
C	33-48	\$5.90
D	49-96	\$9.15
E	97-144	\$11.85
F	145-192	\$14.00
G	193-240	\$16.15
H	241-288	\$17.20
I	289-352	\$19.35
J	353-416	\$22.60
K	417-480	\$25.80
L	481-544	\$30.10
M	545-608	\$34.40
N	609-672	\$38.70
O	673-736	\$43.00
P	737-800	\$47.30

#### ADVERTISERS PLEASE NOTE

As from 22 March 2001

The last Special Gazette was No. 30 dated 21 March 2001

The last Periodical Gazette was No. 1 dated 22 June 2000

## CONTENTS

	Page
Estates of Deceased Persons	479
Government and Outer Budget Sector	
Agencies Notices	486
Orders in Council—	505
Acts — Constitution; Public Lotteries; Parliamentary Committees; Local Government	
Private Advertisements	479
Proclamations	485

The Victoria Government Gazette is published by The Craftsman Press Pty. Ltd. with the authority of the Government Printer for the State of Victoria  
© State of Victoria 2001

ISSN 0819-5471

This publication is copyright. No parts may be reproduced by any process except in accordance with the provisions of the Copyright Act.

Products and services advertised in this publication are not endorsed by The Craftsman Press Pty. Ltd. or the State of Victoria and neither of them accepts any responsibility for the content or the quality of reproduction. The Craftsman Press Pty. Ltd. reserves the right to reject any advertising material it considers unsuitable for government publication.

Address all enquiries to the Government Printer for the State of Victoria  
Government Information and Communications Branch  
Department of Premier and Cabinet  
Level 3, 356 Collins Street  
Melbourne 3000  
Victoria Australia

### RETAIL SALES

Information Victoria Bookshop  
356 Collins Street Melbourne 3000.  
Telephone enquiries 1300 366 356

City Graphics  
Level 1, 520 Bourke Street  
Melbourne 3000  
Telephone enquiries (03) 9600 0977

**Recommended Retail Price \$1.70**

*Government and Outer Budget Sector Agencies please note:*  
**STYLE REQUIREMENTS.**

To ensure that material received can be reproduced, and that errors are minimised, the following guidelines are to be observed when submitting material by fax.

**Fax resolution:**

Material sent by fax should be transmitted using Fine Resolution (200 dots per inch by 200 dpi).

**Font size:**

Use 12 point (10 pitch) or larger.

**Font Style:**

Clear plain font styles, such as Helvetica, should be used.

**Graphics:**

Line drawings should be transmitted as large as possible to ensure clarity. Drawings up to A4 size sent by fax using Fine Resolution provide a good quality for reproduction.

**Avoid:**

Italics, underlining and full justification.

Ensure document is square when sending as documents that are sent skewed are difficult to read and process.

ISSN 0819-5471



9 770819 548635