



Victoria Government Gazette

No. G 17 Thursday 26 April 2001

GENERAL

GENERAL AND PERIODICAL GAZETTE

Copy to: Gazette Officer
The Craftsman Press Pty. Ltd.
125 Highbury Road,
Burwood Vic 3125
Telephone: (03) 9926 1233
Facsimile: (03) 9926 1292
DX: 32510 Burwood
Email: gazette@craftpress.com.au

Advertising Rates and Payment

Private Notices

Payment must be received in advance with advertisement details.

30 cents per word - Full page \$180.00.

Additional costs must be included in prepayment if a copy of the gazette is required. Copy Prices - Page \$1.50 - Gazette \$3.20 Certified copy of Gazette \$3.50. (all prices include Postage). **Cheques should be made payable to The Craftsman Press Pty. Ltd.**

Government and Outer Budget Sector Agencies Notices

Not required to pre-pay.

Advertisements may be faxed or sent via email with a cover sheet, marked to the attention of the Gazette Officer. Floppy Disks (Mac & PC) can also be accepted.

Costs can be calculated on the following basis:

Per Line	Typeset
Single column	\$1.55
Double column	\$3.10
Full Page	\$64.80

The Craftsman Press is pleased to offer a series of discounts from the typesetting costs.

1. Copy supplied on disk.
2. Copy supplied via email.
3. Artwork for forms and other material which require exact reproduction.

1. Copy supplied on disk.

Where a disk is supplied and there is minimum alteration required, **30% off.**

Where a disk is supplied requiring extraneous matter stripped out and styles applied, **20% off.**

2. Copy supplied via email.

Where a notice is sent via email and there is minimum alteration required, **25% off.**

Where email is supplied requiring extraneous matter stripped out and styles applied, **15% off.**

3. Artwork for forms and other material which requires exact reproduction.

Scanning and sizing of artwork for forms, to be reproduced in page format, **35% off.**

Copy Deadline for General Gazette

9.30 a.m. Monday - (Private Notices)

9.30 a.m. Tuesday - (Government and Outer Budget Sector Agencies Notices)

Advertisers should note:

- Late copy received at The Craftsman Press Pty. Ltd. after deadlines will be placed in the following issue of VGG, irrespective of any date/s mentioned in the copy (unless otherwise advised).
- Proofs will be supplied only when requested or at the direction of the Gazette Officer.
- No additions or amendments to material for publications will be accepted by telephone.
- Orders in Council may be lodged prior to receiving assent with the Governor's or Clerk's signature. They will only be published once approved and signed.
- Government and Outer Budget Sector Agencies please note: *See style requirements on back page.*

SPECIAL GAZETTES

Copy to: Gazette Officer
The Craftsman Press Pty. Ltd.
125 Highbury Road,
Burwood Vic 3125
Telephone: (03) 9926 1233
Facsimile: (03) 9926 1292
Email: gazette@craftpress.com.au

Advertising Rates and Payment

Private Notices

Full Page \$360.00

Payment must be received in advance with notice details.

Government and Outer Budget Sector Agencies Notices

	Typeset
Full Page	\$87.50

Note:

The after hours number for Special Gazettes is:
Telephone: 0419 327 321

SUBSCRIPTIONS AND RETAIL SALES

Copies of the Victoria Government Gazette can be purchased from The Craftsman Press Pty. Ltd. by subscription.

The Victoria Government Gazette

General and Special - \$170.00 each year

General, Special and Periodical - \$227.00 each year

Periodical - \$113.00 each year

Subscriptions are payable in advance and accepted for a period of one year. All subscriptions are on a firm basis and refunds will not be given.

All payments should be made payable to The Craftsman Press Pty. Ltd.

Subscription enquiries:

The Craftsman Press Pty. Ltd.

125 Highbury Road, Burwood Vic 3125

Telephone: (03) 9926 1233

INDEX TO PRIVATE ADVERTISERS

A	MCF Lawyers 714
Alan Wainwright J. Okno & Co. 711	Monash Law 714
Anthony Rose & Mainwaring 711	
B	P
Basile & Co. 711	Perpetual Trustees Limited 714
E	R
E. P. Johnson & Davies 711	Rigby Cooke 714
G	S
G. W. H. Chambers 712	Southall Partners 714
H	T
Harwood Andrews 712	T. J. Mulvany & Co. 715
Heinz & Partners 712	Trivett Keating 715
J	W
James Hopper 712	Wisewoulds 715
K	
Keith Hercules 713	
Kelly & Chapman 713	
L	
Littleton Hackford 713	
Lucas Lawyers 713	
M	
Macpherson & Kelly 713	
Mahonys 714	

PRIVATE ADVERTISEMENTS

DISSOLUTION OF PARTNERSHIP

Notice is hereby given that the partnership heretofore subsisting between Mark Christopher Iles of 4 Glen Court, Hampton Park, Victoria and Peter John Leslie of 37 Myers Road, Bittern, Victoria, carrying on business as Under The Sun Concreting Australia has been dissolved as from 31 December 2000.

Dated 31 March 2001

MARK ILES

DISSOLUTION OF PARTNERSHIP

Notice is hereby given that the partnership heretofore subsisting between Julianne Scealy of 183 Dorking Road, Box Hill North and Janine Wright of 83 Katrina Street, Blackburn North carrying on business as Attention to Detail Household Management has been dissolved as from 1 April 2001.

Dated 27 March 2001

JULIANNE SCEALY

Re: Estate of ELEANOR SABINA WERTHEIM, (also known as Ruth Wertheim), late of 94 Leopold Street, South Yarra, Victoria, senior research fellow, deceased. Creditors, next-of-kin and others having claims in respect of the estate of the deceased, who died on 23 November 2000, are required by the trustee, Jacob Franklin Okno of 6 Kilrush Street, Brighton Beach, Victoria, to send particulars of their claims to him care of the below mentioned lawyers by 17 August 2001 after which date the trustee may convey or distribute the assets having regard only to the claims of which he then has notice.

ALAN WAINWRIGHT J. OKNO & CO.,
lawyers,
3/170 Queen Street, Melbourne.

LAURENCE RUPERT NOBELIUS, late of 36 Finlay Street, Albert Park, Victoria, retired, deceased. Creditors, next-of-kin and others having claims in respect of the estate of the deceased, who died on 5 August 2000, are required by the personal representative of the deceased, Anthony C. Rose of the undermentioned solicitors to send particulars of such claims to him by 28 June 2001 after which date the

personal representative may convey or distribute the assets having regard only to the claims of which he then has notice.

ANTHONY ROSE & MAINWARING,
solicitors,
122 Bridport Street, Albert Park, Vic. 3206.

Re: Estate of MARJORIE ANNE FARY, deceased. In the estate of MARJORIE ANNE FARY, formerly of 110 King George Street, Cohuna, Victoria, but late of Murrayvale Nursing Home, Moama, New South Wales, widow, deceased. Creditors, next-of-kin and all other persons having claims against the estate of the said deceased, are required by Geoffrey William Fary of 22 Chaucer Street, Moonee Ponds, Victoria and Geraldine Anne Stills of Watson Street, Echuca, the aforesaid executors of the estate of the said deceased to send particulars of such claims to them in care of the undermentioned solicitors within two months from the date of publication of this notice, after which date they will distribute the assets having regard only to the claims of which they then have notice.

BASILE & CO PTY LTD.,
barristers & solicitors,
46 Wellington Street, Kerang, Vic. 3579.

Re: ANNE HOPE DREYER, deceased. Creditors, next-of-kin or others having claims in respect of the estate of ANNE HOPE DREYER, late of 220 Middleborough Road, Blackburn South, Victoria, pre-school teacher, deceased, who died on 22 January 2001, are to send particulars of their claims to the executor care of the undermentioned solicitors by 29 June 2001 after which date the executor will distribute the assets having regard only to the claims of which the executor then has notice.

E. P. JOHNSON & DAVIES, solicitors,
30 Collins Street, Melbourne 3000.

Re: GLADYS BEATRICE VICTORIA KILBY, deceased. Creditors, next-of-kin or others having claims in respect of the estate of GLADYS BEATRICE VICTORIA KILBY, late of 220 Middleborough Road, Blackburn South, Victoria, but formerly of 5 Thiele Street, Doncaster, Victoria, retired nursing sister, deceased, who died on 15 January 2001, are to send particulars of their claims to the executor care of the undermentioned solicitors by 29 June

2001 after which date the executor will distribute the assets having regard only to the claims of which the executor then has notice.

E. P. JOHNSON & DAVIES, solicitors,
30 Collins Street, Melbourne 3000.

ALMA MAYZIE CRANCH, late of Unit 45, Greenways Retirement Village, 330 Frankston-Dandenong Road, Seaford. Creditors, next-of-kin and others having claims in respect of the estate of the deceased, who died on 1 March 2001, are required by the trustee, care of G.W.H. Chambers, solicitor of 338 Charman Road, Cheltenham, to send particulars to him by 26 June 2001 after which date the trustee may convey or distribute the assets having regard only to the claims of which he then has notice.

G.W.H. CHAMBERS, solicitor,
338 Charman Road, Cheltenham 3192.

FREDERICK GRAHAM KIESEKER, late of 975 Centre Road, Bentleigh East. Creditors, next-of-kin and others having claims in respect of the estate of the deceased, who died on 19 February 2001, are required by the trustee, care of G.W.H. Chambers, solicitor of 338 Charman Road, Cheltenham, to send particulars to her by 26 June 2001 after which date the trustee may convey or distribute the assets having regard only to the claims of which she then has notice.

G.W.H. CHAMBERS, solicitor,
338 Charman Road, Cheltenham 3192.

FERID LOKVANCIC, late of 2 Seville Court, Cheltenham. Creditors, next-of-kin and others having claims in respect of the estate of the deceased, who died on 15 February 2001, are required by the trustee, care of G.W.H. Chambers, solicitor of 338 Charman Road, Cheltenham, to send particulars to her by 26 June 2001 after which date the trustee may convey or distribute the assets having regard only to the claims of which she then has notice.

G.W.H. CHAMBERS, solicitor,
338 Charman Road, Cheltenham 3192.

WILLIAM GORDON VOLUM, late of 11 Hutchinson Avenue, Beaumaris, accountant. Creditors, next-of-kin and others having claims in respect of the estate of the deceased, who died on 7 October 2000, are required by the executors of the deceased's will to send particulars to them care of the undermentioned

lawyers by 27 June 2001 after which date the executors may convey or distribute the assets having regard only to the claims of which they then have notice.

HARWOOD ANDREWS, lawyers,
70 Gheringhap Street, Geelong 3220.

Re: LILLIAN HILDA SIMPER, deceased. Creditors, next-of-kin and others having claims in respect of the estate of LILLIAN HILDA SIMPER late of 1 Gladstone Street, Ballarat, widow, deceased, who died on 20 November 2000, are to send particulars of their claims to the executors care of the undermentioned solicitors by 26 June 2001 after which date the executors will distribute the assets having regard only to the claims of which the executors then have notice.

HEINZ & PARTNERS, solicitors,
6 Dawson Street North, Ballarat.

Re: BARBARA JUNE TRICKEY, deceased. Creditors, next-of-kin and others having claims in respect of the estate of BARBARA JUNE TRICKEY late of Unit 1, 10 Stewart Street, Portland, home duties, deceased, who died on 6 March 2001, are to send particulars of their claims to the executors care of the undermentioned solicitors by 26 June 2001 after which date the executors will distribute the assets having regard only to the claims of which the executors then have notice.

HEINZ & PARTNERS, solicitors,
6 Dawson Street North, Ballarat.

GEORGE WILLIAM TITMUS, late of 58 Auburn Grove, Hawthorn East, retired, deceased. Creditors, next-of-kin and others having claims in respect of the estate of the abovenamed deceased, who died on 18 June 2000, are required to send particulars of their claims to the administratrix, Adrienne Anina Kennedy, care of the undernoted solicitors by 7 July 2001 after which date she will convey or distribute the assets having regard only to the claims of which she then has notice.

JAMES HOPPER, solicitor,
409 Whitehorse Road, Balwyn.

JEAN MARGARET JONES, late of 4 Stafford Court, East Ivanhoe. Creditors,

next-of-kin and others having claims in respect of the estate of the deceased, who died on 26 January 2001, are required by the trustees, Allan Leigh Jones and Margaret Anne Jonas, both of 185 Ryans Road, Eltham North, to send particulars to them by 29 June 2001 after which date the trustees may convey or distribute the assets having regard only to the claims of which they then have notice.

KEITH HERCULES, solicitors,
Suite 3, 456 St. Kilda Road, Melbourne 3004.

MAREE WILSON, late of 4 Crisp Street, Essendon, married woman, deceased. Creditors, next-of-kin and others having claims in respect of the estate of the deceased, who died on 29 December 2000, are required by the executor, Joseph Raymond Wilson of 4 Crisp Street, Essendon, driver, to send particulars to him by 29 June 2001 after which date the executor may convey or distribute the assets having regard only to the claims of which he then has notice.

KEITH HERCULES, solicitors,
Suite 3, 456 St. Kilda Road, Melbourne 3004.

Creditors, next-of-kin and others having claims in respect of the estate of CHARLES HENRY HARGRAVES, deceased, late of 81 North Avenue, Bentleigh, in the State of Victoria, retired plastering contractor, who died on 16 March 2001, are required by Valerie Hargraves of 81 North Avenue, Bentleigh, aforesaid, widow, who is applying to the Supreme Court for a Grant of Probate of the deceased's last will and testament dated 8 May 1981 and Codicil dated 14 November 1996, to send particulars of such claims to the solicitors acting for the said executors, namely Kelly & Chapman of 437 Centre Road, Bentleigh by 5 July 2001 after which date the said executor may convey or distribute the assets of the deceased having regard only to the claims of which they or their solicitors then have notice.

KELLY & CHAPMAN, solicitors,
437 Centre Road, Bentleigh 3204.
Solicitors for the executors.

Creditors, next-of-kin and others having claims in respect of the estate of NORMAN HENRY PAULET, late of Maxfields Road, Upper Flynn, Victoria, farmer, deceased, who died on 27 March 2001, are to send their claims to the trustee, Gwenda Holly Paulet of

Maxfields Road, Upper Flynn, Victoria, care of the below mentioned solicitors by 26 June 2001 after which date she will distribute the assets of the deceased having regard only to the claims of which she then has notice.

LITTLETON HACKFORD, solicitors,
Law Chambers,
115 Hotham Street, Traralgon, Vic. 3844.

PATRICIA NANCY HEMMINGS, late of 11 Seventh Street, Parkdale 3194, retired hairdresser, deceased. Creditors, next-of-kin and others having claims in respect of the estate of the deceased, who died on 30 January 2001, are required by the executrix, Glenys Elizabeth Vandenberg of 9 Marella Place, Narre Warren South 3805, to send particulars to her care of the undermentioned solicitors by 2 July 2001 after which date the executrix may convey or distribute the assets having regard only to the claims of which she then has notice.

LUCAS LAWYERS, solicitors,
8 Station Road, Cheltenham 3192.

KENNETH JOHN McLEMON of 3 Margaretta Street, East Bentleigh, deceased. Creditors, next-of-kin and others having claims in respect of the estate of the deceased, who died on 13 June 2000, are required by Shaun Walker of Unit 3, 5 Hazel Street, Camberwell, analyst, the executor of the will of the said deceased, to send particulars to him care of the undermentioned solicitors by 26 June 2001 after which date the said executor may convey or distribute the assets having regard only to the claims of which he then has notice.

MACPHERSON + KELLY, lawyers,
40-42 Scott Street, Dandenong 3175.

IVY JEAN ROWLAND of Elanora Nursing Home, 7 Mair Street, Brighton deceased. Creditors, next-of-kin and others having claims in respect of the estate of the deceased, who died on 24 August 2000, are required by Permanent Trustee Company Limited of 294-296 Collins Street, Melbourne, the executor of the will of the said deceased, to send particulars to it in the care of the undermentioned solicitors by 26 June 2001 after which date the said executor may convey or distribute the assets having regard only to the claims of which it then has notice.

MACPHERSON + KELLY, lawyers,
40-42 Scott Street, Dandenong 3175.

Re: WARREN ALEXANDER McCRAE HOWITT, deceased. Creditors, next-of-kin and others having claims against the estate of WARREN ALEXANDER McCRAE HOWITT, deceased, late of 9 Lochabar Court, Ivanhoe, Victoria, company director, who died on 20 December 2000, are required to send particulars of their claims to the executors, Robert Bruce Carpenter and Sandra Joy Rowe, care of Mahonys, Solicitors, 400 Collins Street, Melbourne, Victoria, by 29 June 2001 after which date the executors will convey and distribute the said estate having regard only to the claims of which the executors then have notice.

MAHONYS, solicitors,
400 Collins Street, Melbourne.

Creditors, next-of-kin and others having claims in respect of the estate of SALVATORE BURGIO, late of 67 Maribyrnong Road, Ascot Vale, retired, deceased, who died on 21 February 2001, are requested to send particulars of their claims to the executrix, Myriam Cesar Fiumani, care of the undermentioned solicitors on or before 27 June 2001 after which date they will distribute the assets having regard only to the claims of which they then have notice.

MCF LAWYERS,
70 Bulla Road, North Essendon 3041.

RUBY VICTORIA GUEST, late of Bambra House, 5 Bambra Road, Caulfield North, Victoria, gentlewoman, deceased. Creditors, next-of-kin and others having claim in respect of the estate of the deceased, who died on 5 August 2000, are required by the executor, Clive Maxwell Nicholson of 1 Calgary Court, Glen Waverley, to send particulars to him by 29 June 2001 after which date he may convey or distribute the assets having regard only to the claims of which he then has notice.

MONASH LAW, solicitors,
1 Calgary Court, Glen Waverley 3150.

MOLLIE UNA ARMSTRONG, late of 12 Kaumple Street, Pascoe Vale, Victoria 3044. Creditors, next-of-kin and others having claims in respect of the estate of the deceased, who died on 21 September 2000, are required by Perpetual Trustees Victoria Limited, A.C.N. 004 027 258 of 360 Collins Street, Melbourne, Victoria, to send particulars of their claims to the said

company by 27 June 2001 after which date it will convey or distribute the assets having regard only to the claims of which the company then has notice.

ESME BEATRICE CROWE, late of 31 Vasey Street, East Bentleigh, Victoria 3165. Creditors, next-of-kin and others having claims in respect of the estate of the deceased, who died on 4 October 2000, are required by Perpetual Trustees Victoria Limited, A.C.N. 004 027 258 of 360 Collins Street, Melbourne, Victoria, to send particulars of their claims to the said company by 27 June 2001 after which date it will convey or distribute the assets having regard only to the claims of which the company then has notice.

RICHARD FRANCIS RUSSELL, late of Caulfield General Medical Centre, 260–294 Kooyong Road, Caulfield. Creditors, next-of-kin and others having claims in respect of the estate of the deceased, who died on 11 July 2000, are required by Perpetual Trustees Victoria Limited, A.C.N. 004 027 258 of 360 Collins Street, Melbourne, Victoria, to send particulars of their claims to the said company by 27 June 2001 after which date it will convey or distribute the assets having regard only to the claims of which the company then has notice.

Creditors, next-of-kin or others having claims in respect of the estate of DAPHNE ROSE GRAHAM, late of 55 Walpole Street, Kew, Victoria 3101, spinster, deceased, who died on 12 January 2001, are to send particulars of their claims to the executor care of the undermentioned solicitors by 28 June 2001 after which date the executor will distribute the assets having regard only to the claims of which the executor then has notice.

RIGBY COOKE, solicitors,
469 La Trobe Street, Melbourne 3000.

GRETE SELMA SCHULT, late of 9/2 Redan Street, St Kilda, Victoria, retired nursing sister, deceased. Creditors, next-of-kin and others having claims in respect of the estate of the deceased, who died on 11 October 2000, are required by Michael Sidney Lawrence, Lynette Thea Lawrence and Christopher John Southall, the executors of the will of the deceased, to send particulars of their claims to them care of the undermentioned solicitors by

3 July 2001 after which date they will convey or distribute the assets having regard only to the claims of which they then have notice.

SOUTHALL PARTNERS, solicitors,
Level 1, 10 Cecil Place, Prahran 3181.

JOHN WILLIAM KEY, late of St Judes Nursing Home, 2 Newton Street, Chadstone, Victoria, retired, deceased. Creditors, next-of-kin and others having claims in respect of the estate of the abovenamed deceased, who died on 2 September 2000, are to send particulars of their claims to the executor, Giuseppe Joseph Toscano, care of the undermentioned solicitors by 29 June 2001 after which date the said executor will distribute the assets having regard only to those claims of which he then has notice.

T. J. MULVANY & CO., solicitors,
2nd Floor, 51 Queen Street, Melbourne 3000.

Re: EVA AGNES MARKS, deceased, late of Unit 4, 6 Charles Street, Wodonga. Creditors, next-of-kin and others having claims in respect of the estate of the deceased, who died on 29 July 2000, are required by the trustee of the estate of the deceased, Faye Elizabeth Marks, care of 9 Stanley Street, Wodonga, to send particulars to her by 22 June 2001 after which date the trustee may convey or distribute the assets having regard only to the claims of which they then have notice.

Dated 10 April 2001

TRIVETT KEATING, legal practitioners,
1st Floor, 9 Stanley Street, Wodonga.
Telephone: (02) 6024 3555.

LOUIS AUBREY MULRONEY, late of 61 Station Street, Wallan East, Victoria, retired, deceased. Creditors, next-of-kin and others having claims in respect of the estate of the abovenamed deceased, who died on 1 January 2001, are required by the executors, Elizabeth Ann Owen of 6 Balamara Court, Frankston and Brian Jeffrey Mulroney of 61 Station Street, Wallan East, to send particulars to the executors by 29 June 2001 after which date the executors intend to convey or distribute the assets of the estate having regard only to the claims of which the executors may have notice.

WISEWOULDS, solicitors,
459 Collins Street, Melbourne.

Unclaimed Moneys Act 1962

Register of Unclaimed Moneys held by the —

<i>Name of Owner on Books and Last Known Address</i>	<i>Total Amount Due to Owner</i>	<i>Description Of Unclaimed Money</i>	<i>Date when Amount first became Payable</i>
AMCIL LIMITED			
	\$		
Mrs Vibeke Armstrong, 90 Springvale Road, Killara, NSW	180.00	Cheque	10/09/99
Mr David Walter Harold Berry, PO Box 56-004, Tawa, Wellington, New Zealand	300.00	"	15/03/99
Mr David Walter Harold Berry, PO Box 56-004, Tawa, Wellington, New Zealand	450.00	"	10/09/99
Mr Austen William Langford, "Austen Langford Family A/C", 302 Wattleup Road, Wattleup, WA	225.00	"	"
Mrs Elizabeth Sherbon Loder, PO Box 270, Kew East	240.00	"	15/03/99
Ms Catherine Mary Therese McCarthy, "McCarthy Family A/C", Unit 4, 40 Kingsmill Street Chermshire, Qld	675.00	"	10/09/99
Royal Australian College of Physicians, "Endowments A/C", PO Box 10-628, Wellington 6036, New Zealand	225.00	"	15/03/99
Royal Australian College of Physicians, "NZ Committee A/C", PO Box 10-628, Wellington 6036, New Zealand	150.00	"	15/03/99

01109

CONTACT: MARY BLACKBURN, PHONE: (03) 9615 9837.

Unclaimed Moneys Act 1962

Register of Unclaimed Moneys held by the —

<i>Name of Owner on Books and Last Known Address</i>	<i>Total Amount Due to Owner</i>	<i>Description Of Unclaimed Money</i>	<i>Date when Amount first became Payable</i>
AUSDOC GROUP LIMITED			
	\$		
Afendi Pty Ltd, "Super Fund A/C", Attn:Nikolas Hatzistergos, Level 16, 456 Kent Street, Sydney, NSW	375.00	Cheque	30/09/99
Mrs Valerie Brady, PO Box 66, Wodonga	135.00	"	"
Betty Chorley, 13 Neeworra Road, Northbridge, NSW	188.78	"	"

Mr John Gaunt, "Global Directors Fund A/C", PO Box 243, North Melbourne	180.00	"	31/03/99
Mr John Gaunt, "Global Directors Fund A/C", PO Box 243, North Melbourne	225.00	"	30/09/99
Mrs Lorna Hannan, 20 Shiel Street, North Melbourne	247.50	"	"
Mr Maurice Peter Keating, Unit 1/11, Moffat St, South Yarra	428.55	"	"
Mr John Graeme Larkins, 205 William Street, Melbourne	238.88	"	"
Mr David Keith McCullough & Mrs Christine Ann McCullough, "Davchris Super Fund A/C", 11 Duckett Street, Doncaster East	135.00	"	"
Mr David Keith McCullough & Mrs Christine Ann McCullough, "Davchris Super Fund A/C", 11 Duckett Street, Doncaster East	108.00	"	31/03/99
Mr Rauna Hamiora Murray, 22 Yallambee Drive, Bendigo	141.00	"	30/09/99
Mr John Stephen Zonneveld, 4/12 Lewisham Rd, Prahran	106.20	"	"

01110

CONTACT: MARY BLACKBURN, PHONE: (03) 9615 9837.

Unclaimed Moneys Act 1962

Register of Unclaimed Moneys held by the —

<i>Name of Owner on Books and Last Known Address</i>	<i>Total Amount Due to Owner</i>	<i>Description Of Unclaimed Money</i>	<i>Date when Amount first became Payable</i>
AUSTRALIAN FOUNDATION INVESTMENT CO LTD			
\$			
Mr Matthew Denis Adams, Unit 10, 2a Baillie Street, North Melbourne	253.75	Cheque	11/08/99
Mrs Lois Clare Anderson, PO Box 55, Maroochydore, Qld	1,309.06	"	"
Mr Peter Geoffrey Grant Annand, 37 Paten Road, The Gap, Qld	3,605.79	"	"
Mr Timothy James Armstrong, Unit 5, 145 Hastings Parade, Bondi North, NSW	256.00	"	"
Ms Christine Aubrey, "Georgina Aubrey A/C", 9 Bungoona Road, Elanora Heights, NSW	100.85	"	"
Mr Robert Norman Barnard & Mrs Janet Annie Barnard, 8 Power Street, Wavell Heights, Qld	145.00	"	"
Mr Andrew Cameron Belcher, 7a Duke St, Ashburton Estate Nancy Benko,	438.55	"	"
C/- Wallmans, GPO Box 1018, Adelaide, SA	275.50	"	"
Ms Rosemary Insie Berry & Ms Ann Virginia Hooper, C/- 34 Rotherwood Street, Richmond	145.07	"	"
Mrs Marjorie Blanchard, Unit 5, 13 Ozanam Village, Neptune Street, Revesby, NSW	384.25	"	"

Mr Gordon Bowen & Estate Gladys Bowen, 13 Madeleine Street, Doncaster	329.37	''	''
Mr Gordon Bowen, 13 Madeleine Street, Doncaster	2,635.01	''	''
Ingrid Bay Brant & Philip Nunn Barton, 8720 River Meadow Road, Carmel Ca 93923, United States of America	3,684.38	''	15/03/99
Mr James David Oswald Burns, PO Box 29, Bowral, NSW	1,794.38	''	11/08/99
Ruby Francis Alice Butler, 74 Alderley Street, Toowoomba, Qld	2,059.44	''	''
Mr Liberat Coppens, Rue De La Croisette, 27 7911 Frasnés Lez Buissenal, (Hainaut) Belgium	247.37	''	''
Cecily Anne Cowan & Rowena Anne Tennant, C/- 47 Kpmg Peat Marwick, GPO Box 2499, Adelaide, SA	2,982.65	''	''
Mr James B K Cowan & Ms Cecily A Cowan, C/- 47 Kpmg Peat Marwick, GPO Box 2499, Adelaide, SA	3,509.00	''	''
Mr Ross Dalrymple, "A Dalrymple Memorial Fund A/C", C/- Fiona Slocombe, 25 Wells Road, Beaumaris	198.45	''	15/03/99
Mr Ross Dalrymple, "A Dalrymple Memorial Fund A/C", C/- Fiona Slocombe, 25 Wells Road, Beaumaris	319.73	''	11/08/99
Miss Kate Davies, 20b Hill Street, Toorak	688.75	''	''
Bettina Yuen Seng Fong, 1 Embling Road, Malvern	238.89	''	''
Bettina Yuen Seng Fong, 1 Embling Road, Malvern	148.28	''	15/03/99
Forrest Concreting Pty Ltd, "Forrest Super Fund A/C", 127 Breen Street, Bendigo	159.50	''	11/08/99
Miss Peggy H Gilkes, C/- A N Z Bank, Martin Place, Sydney, NSW	178.79	''	''
Miss Peggy H Gilkes, C/- A N Z Bank, Martin Place, Sydney, NSW	110.97	''	15/03/99
Mrs Joan Beatrice Gillen, PO Box 377, Toorak	407.89	''	11/08/99
Mrs Patricia G Gratton, PO Box 3018, Norwood, SA	1,617.48	''	15/03/99
Mr Nicholas John Griffin, 17 Mellington St, Dulwich, SA	145.00	''	11/08/99
Mr Bryan L Harper, 14 Malmsbury Street, Kew	625.24	''	''
Mr Danny Harris, C/- Mrs Michelle Harris, 10 Rosehill Avenue, Caulfield	101.25	''	15/03/99
Mr Danny Harris, C/- Mrs Michelle Harris, 10 Rosehill Avenue, Caulfield	163.13	''	11/08/99
Mr Sean Harris, C/- Mrs Michelle Harris 10 Rosehill Avenue, Caulfield	132.31	''	''
Miss Diana N Hayter, 23 Chifley Crescent, Trott Park, SA	107.60	''	15/03/99
Mr Gerard Paul Healy, C/- Mrs K M Carter, 56 Windmill Street, Tarragindi, Qld	170.06	''	''
Mr Gerard Paul Healy, C/- Mrs K M Carter, 56 Windmill Street, Tarragindi, Qld	273.98	''	11/08/99
Clive Roy Hoffmann & Philip James Hoffmann, 166 Jetty Road, Glenelg, SA	263.18	''	''
Grace Hould, PO Box 474, Camberwell	834.98	''	''
Grace Hould, PO Box 474, Camberwell	465.12	''	15/03/99
Mr Graeme Thomas Inkster, 16/7 Garden St, Telopea, NSW	350.90	''	11/08/99
Mr Graeme Thomas Inkster, 16/7 Garden St, Telopea, NSW	217.80	''	15/03/99
JBW Australia Nominees Pty Ltd, "Accumulation Entrepot A/C",			

C/- J B Were & Son, 15th Floor, 101 Collins St, Melbourne	783.00	''	11/08/99
Jelm Creations Pty Ltd, 39 Kiwi Street, Sheldon, Qld	894.80	''	''
Mr Edward Malcolm Mackay Phillips Jones, C/- Unit 7, 54 Anderson Street, South Yarra	101.57	''	''
Mr James Edward Phillips Jones, C/- Unit 7, 54 Anderson Street, South Yarra	101.57	''	''
Mr Lachlan James Mackay Phillips Jones, C/- Unit 7, 54 Anderson Street, South Yarra	101.57	''	''
Mr William Stevan Mackay Phillips Jones, C/- Unit 7, 54 Anderson Street, South Yarra	101.57	''	''
Miss Erin Kelly & Mr Daniel Kelly, 19 Barnetts Road, Berowra Heights, NSW	144.71	''	''
Carol Sybil Mountford-Lamey, R R # 1 Afton Nova Scotia Canada Boh 1a0	107.91	''	15/03/99
Carol Sybil Mountford-Lamey, R R # 1 Afton Nova Scotia Canada Boh 1a0	173.86	''	11/08/99
Dr Helen Olga Light, 260 Richardson Street, Middle Park Est Clive Ronald Bruno Lister, C/- Beverly K Hartline, 1094 Big Rock Loop, Los Alamos, Nm 87544, United States of America	126.88	''	''
Est Clive Ronald Bruno Lister, C/- Beverly K Hartline, 1094 Big Rock Loop, Los Alamos, Nm 87544, United States of America	115.34	''	15/03/99
Mr Angus Brien Lohmeyer, Feder Road, Mylor, SA	185.82	''	11/08/99
Mrs Giorsal Freda Lyall, 18 Alexander Street, Mitcham	114.19	''	''
Walter Arthur R Matthews & Margaret Gertrude Matthews, 6 Sedger Road, Kenthurst, NSW	113.97	''	''
Mr Paul James McGann, "Mathew McGann A/C", 36 Royal Street, Tuart Hill, WA	266.44	''	''
Mr Paul James McGann, "Mathew McGann A/C", 36 Royal Street, Tuart Hill, WA	236.25	''	15/03/99
Ms Alexandra Meyrick Milne, 187 Fisher St, Malvern, SA	380.63	''	11/08/99
Ms Alexandra Meyrick Milne, 187 Fisher St, Malvern, SA	164.72	''	''
Mr Rocco Monaco & Mrs Grace Monaco, 103 Ledger Road, Beverley, SA	102.24	''	15/03/99
Mr Colin Morgan, 90 Auckland Street, Gladstone, Qld	159.50	''	11/08/99
Mr Colin Morgan, 90 Auckland Street, Gladstone, Qld	210.54	''	''
Simon Travis Mundy, Rsd 46, Gumeracha, SA	130.68	''	15/03/99
Mr David Allan Norrie, 8 Wharf Road, Birchgrove, NSW	836.87	''	11/08/99
Estate Nancy L Norrie, 39 Branch Avenue, Fig Tree, NSW	247.30	''	''
Mr Kenneth O'Connor, "Miss Erin O'Connor A/C", Mathieson Road, Erica	100.35	''	15/03/99
Mr Ulric G Orr, Fortuna Lodge, 100 Smith Street, Lorne	203.00	''	11/08/99
Elizabeth Lauren Owen, C/- Apartment E, 1st Floor, 7 Stanley Beach Road, Stanley, Hong Kong	821.28	''	''
Elizabeth Lauren Owen, C/- Apartment E, 1st Floor, 7 Stanley Beach Road, Stanley, Hong Kong	272.25	''	15/03/99
Mrs Patricia Glory Pahlow, 13 Redcourt Avenue, Armadale	438.63	''	11/08/99
Mr Robert Anthony Parker, 54 Neville Street, Wattle Park	277.39	''	''
Est Mr Ronald Edwin Paton, E P Johnson & Davies Solicitors, 30 Collins Street, Melbourne	217.50	''	''
Peninsula Village Limited, PO Box 333, Woy Woy, NSW	2,181.60	''	''
	1,254.11	''	''

Mr William Ian Potter, 28 The Esplanade, Clifton Hill	786.78	''	15/03/99
Karumathil Rajan, Joseph Charles Learmonth Duffy, The Hyatt Centre, 87 Adelaide Terrace, Perth, WA	110.21	''	''
Karumathil Rajan, Joseph Charles Learmonth Duffy, The Hyatt Centre, 87 Adelaide Terrace, Perth, WA	177.55	''	11/08/99
Estate Alwyn Arthur Ray, C/- Stephen Holmes, PO Box 3200, Erina, NSW	673.79	''	15/03/99
Major Stanley Richardson, PO Box No 2023, Singapore	577.17	''	''
Major Stanley Richardson, PO Box No 2023, Singapore	929.89	''	11/08/99
Ridgehaven Joinery Pty Ltd, "The Brown Family Ex S/F A/C", 2 Goodes Road, Ridgehaven, SA	130.50	''	''
The Rotary Club of Footscray Incorporated, "Csh Friendship Fund A/C", PO Box 2253, Footscray	2,111.64	''	''
Shergold Investments Pty Ltd, 36 Walsh Street, South Yarra	1,390.62	''	''
Miss Amanda Louise Shiels & Miss Megan Kate Shiels & Miss Katherine Alice Shiels, 39 Alta Street, Canterbury	119.77	''	''
Ms Annabel Kate Smart, 175 Sutherland Street, Paddington, NSW	290.00	''	''
Estate Andrew W Stevens, C/-L J Stevens, The Wattles, Burwood Road, East Burwood	101.57	''	''
Mr David John Stewart, 12 Bligh Avenue, Panorama, SA	101.25	''	30/09/99
Mr Michael Alan Stubbs, Unit 3, 6 Waratah Avenue, Glenhuntly	260.42	''	15/03/99
Mrs Sally C F Tait, PO Box 147, Yeppoon, Qld	165.02	''	''
Mrs Sally C F Tait, PO Box 147, Yeppoon, Qld	265.86	''	11/08/99
Mr Stewart Shaw-Taylor, 50 Rowland Street, Kew	166.50	''	15/03/99
Estate William A Thompson, Tebbutt Lodge, 40a Stewart Street, Dundas, NSW	225.50	''	''
Estate William A Thompson, Tebbutt Lodge, 40a Stewart Street, Dundas, NSW	363.30	''	11/08/99
Toronto Court Pty Ltd, 10 South Avenue, Altona Meadows	163.35	''	15/03/99
Toronto Court Pty Ltd, 10 South Avenue, Altona Meadows	263.18	''	11/08/99
Est Margaret M Troy, C/- M F Lyons & Associates, GPO Box 885, Brisbane Qld	462.33	''	''
Mrs Carol D M Von Furstenrecht, PO Box 576, Alyangula, NT	269.51	''	15/03/99
Mr Scott Richard Walker, 21 Weerona Avenue, Mt Stuart, Tas.	102.37	''	11/08/99
Mr Jonothan Michael Walmsley, 2 Prosper Parade, Glen Iris	126.88	''	''
Mr Walter Weber Kirchröderstr 44, D-30625 Hannover, Germany	315.00	''	15/03/99
Mr Walter Weber Kirchröderstr 44, D-30625 Hannover, Germany	507.50	''	11/08/99

01107

CONTACT: MARY BLACKBURN, PHONE: (03) 9615 9837.

Unclaimed Moneys Act 1962

Register of Unclaimed Moneys held by the —

<i>Name of Owner on Books and Last Known Address</i>	<i>Total Amount Due to Owner</i>	<i>Description Of Unclaimed Money</i>	<i>Date when Amount first became Payable</i>
AUSTRALIAN FOUNDATION INVESTMENT CO LTD			
\$			
MrsCarolynn Margaret Boyd, 2 Kakanui Avenue Hamilton 2001, New Zealand	204.80	Cheque	15/03/99
MrsCarolynn Margaret Boyd, 2 Kakanui Avenue Hamilton 2001, New Zealand	344.39	"	11/08/99
Mr Andrew Conyngham Burton & Mr Warwick Deuchrass C/- Pricewaterhousecoopers, PO Box 2029, Auckland, New Zealand	126.30	"	"
Phillip Wayne Cooper & Elizabeth Mary Phillipa Cooper, "Cooper Super A/C", C/- PO Box 1930, Rotorua, New Zealand	355.77	"	"
Helen Mary Cox & James Allan Scotland, "Longview A/C", 2 Greenwood Road, Havelock North 4201, New Zealand	400.24	"	"
Mr Gordon Davidson, C/- Luke Cunningham and Clere, PO Box 10-357, Wellington 6015, New Zealand	139.38	"	"
Est Marjorie Green, 28 Ettrick Avenue, Fleetwood Lincs Fy7 8bu UK	374.35	"	15/03/99
Est Marjorie Green, 28 Ettrick Avenue, Fleetwood Lincs Fy7 8bu UK	633.18	"	11/08/99
Peter Cracroft Grigg, Surrey Hills, R D 1 Ashburton 8300, New Zealand	605.35	"	"
Gerald Guy Hansard, 1038 Aberdeen Road, Gisborne 3, New Zealand	719.98	"	15/03/99
Gerald Guy Hansard, 1038 Aberdeen Road, Gisborne 3, New Zealand	1,210.69	"	11/08/99
Mrs Celia M G Ireland, 42 Westland Drive, Hayes Bromley, Kent, United Kindom	187.92	"	"
Mrs Rosemary Anne Malins & Mr John Charlton Aubrey & Mrs Roseanne Elizabeth Walker 112 River Road, Hamilton, New Zealand	211.57	"	15/03/99
Mrs Rosemary Anne Malins & Mr John Charlton Aubrey & Mrs Roseanne Elizabeth Walker 112 River Road, Hamilton, New Zealand	355.77	"	11/08/99
Lindsay Ronald Mckenzie & Christine Lesley Mckenzie, 43 Craig Street, Invercargill 9500, New Zealand	365.21	"	"
Dr Peter Alexander McKinnon & Mrs Carol Ann McKinnon, 29 Kotare Street, Christchurch 8004, New Zealand	124.52	"	"
Graeme Robertson Mitchell, 87 Kings Crescent, Lower Hutt 6009, New Zealand	576.00	"	15/03/99
Graeme Robertson Mitchell, 87 Kings Crescent, Lower Hutt 6009, New Zealand	968.60	"	11/08/99

Public Trustee, "Est R H Cook", P O Box 31542, Lower Hutt, Wellington 6315	563.02	"	"
Helen Mavis Sinclair, P O Box 37728, Parnell, Auckland 1033, New Zealand	168.99	"	"
Leo James Steel & Warwick John Ainger, PO Box 753, Christchurch 8015, New Zealand	1,423.63	"	"
Kenneth William Talbot & Susan Elizabeth Talbot, 115 Wai-Iti Road, Timaru, New Zealand	225.12	"	"
Te Kawhata Retirement Trust Board, P O Box 31, Te Kawhata 2152, New Zealand	549.75	"	"
Tea Custodians Limited, "C E Goodall Estate Ajm A/C", PO Box 192, Shortland Street, Auckland, New Zealand	257.93	"	"
Tea Custodians Limited, "E K A Guinibert A/C", PO Box 192, Auckland New Zealand	958.89	"	"

01108

CONTACT: MARY BLACKBURN, PHONE: (03) 9615 9837.

Unclaimed Moneys Act 1962

Register of Unclaimed Moneys held by the —

<i>Name of Owner on Books and Last Known Address</i>	<i>Total Amount Due to Owner</i>	<i>Description Of Unclaimed Money</i>	<i>Date when Amount first became Payable</i>
BANYULE CITY COUNCIL			
	\$		
D. Elliot	450.00	Cheque	10/02/99
R. W. & S. M. Starbuck P/L	500.00	"	24/02/99

01101

CONTACT: ROBERT FARALLA, PHONE: (03) 9490 4283.

Unclaimed Moneys Act 1962

Register of Unclaimed Moneys held by the —

<i>Name of Owner on Books and Last Known Address</i>	<i>Total Amount Due to Owner</i>	<i>Description Of Unclaimed Money</i>	<i>Date when Amount first became Payable</i>
CHALMERS LIMITED			
	\$		
Miss Susan Clare Yates, Firwood Cottage, Spaniard's End Hampstead, London NW3 7JG, UK	1,069.20	Cheque	31/03/99

01131

CONTACT: MARY BLACKBURN, PHONE: (03) 9615 9837.

Unclaimed Moneys Act 1962

Register of Unclaimed Moneys held by the —

<i>Name of Owner on Books and Last Known Address</i>	<i>Total Amount Due to Owner</i>	<i>Description Of Unclaimed Money</i>	<i>Date when Amount first became Payable</i>
CITY OF CASEY			
	\$		
A. & R. Nagy, 22 Cottswold Avenue, Narre Warren Turning Point Alcohol & Drug Centre.	129.50	Cheque	12/05/99
54-62 Gertrude Street, Fitzroy	134.00	"	25/06/99
M. & I. De Souza, C/- Belleli King, DX 17542, Dandenong	128.03	"	17/12/99

01034

CONTACT: DOREEN COLLIER, PHONE: (03) 9705 5392.

Unclaimed Moneys Act 1962

Register of Unclaimed Moneys held by the —

<i>Name of Owner on Books and Last Known Address</i>	<i>Total Amount Due to Owner</i>	<i>Description Of Unclaimed Money</i>	<i>Date when Amount first became Payable</i>
DANKS HOLDINGS LIMITED			
	\$		
Mrs Margaret E Bowman, C/- Perpetual Registrars Ltd, 7th Floor, 150 Queen Street, Melbourne	108.00	Cheque	30/11/99
Miss Dianne Collins, 95 Orlando Street, Hampton	108.00	"	"
Bettina Yuen Siang Fong, 1 Embling Road, Malvern	129.60	"	30/04/99
Bettina Yuen Siang Fong, 1 Embling Road, Malvern	180.00	"	30/11/99
Mr Edmund A D Jowett, 7 Doona Avenue, Kew	270.00	"	"
Mr Edmund A D Jowett, 7 Doona Avenue, Kew	194.40	"	30/04/99
Ms Anne Lyell Richter, 253 Beaconsfield Parade, Middle Park	193.25	"	30/11/99
Mr Robert L Simpson, 138 Homebush Rd, Strathfield, NSW	108.00	"	"
Mr Robert West, C/- ASX Perpetual Registrars Ltd, GPO Box 1736p, Melbourne	216.00	"	"
Mr Robert West, C/- ASX Perpetual Registrars Ltd, GPO Box 1736p, Melbourne	155.52	"	30/04/99

01111

CONTACT: MARY BLACKBURN, PHONE: (03) 9615 9837.

Unclaimed Moneys Act 1962

Register of Unclaimed Moneys held by the —

<i>Name of Owner on Books and Last Known Address</i>	<i>Total Amount Due to Owner</i>	<i>Description Of Unclaimed Money</i>	<i>Date when Amount first became Payable</i>
DJERRIWARRH INVESTMENTS LIMITED			
\$			
Mr Robert Norman Barnard & Mrs Janet Annie Barnard, 8 Power Street, Wavell Heights, Qld	165.00	Cheque	11/08/99
Mr David Walter Harold Berry, PO Box 56-004, Tawa, New Zealand	360.00	"	15/03/99
Mr David Walter Harold Berry, PO Box 56-004, Tawa, New Zealand	440.00	"	11/08/99
Mr James David Oswald Burns, PO Box 29, Bowral, NSW	1,100.00	"	"
Mr George John Buttle, 32 Moss Street, Cook, ACT	990.00	"	"
Mr William John Casey & Mr Brian Joseph Casey & Est Patricia Margaret Blackall, "No 2 A/C", PO Box 92, Kilmore	451.00	"	"
Mr William John Casey & Mr Brian Joseph Casey & Est Patricia Margaret Blackall, "No 3 A/C", PO Box 92, Kilmore	451.00	"	"
Mrs Margaret Lynette Collings, 153 Dover Road, Dover Heights, NSW	150.00	"	31/03/99
Ms Flora-Jill Colwell, PO Box 198, Ettalong, NSW	330.00	"	11/08/99
Mr Graeme Edward Cook, 851 Lytton Road, Murarrie, Qld	132.00	"	"
Dr Robert James Craig & Mrs Judith Nora Craig, "Craig Super Fund A/C", 13 Toolaby Avenue, Beaumont, SA	1,622.28	"	"
Mrs Judith Suzanne Day, 50 Riddle Drive, Melton	550.00	"	"
Miss Frances Margaret Fordham, 8 Carcoola Street, Kingston Qld	297.00	"	15/03/99
Miss Frances Margaret Fordham, 8 Carcoola Street, Kingston Qld	121.00	"	11/08/99
Mr Andrew Donald Grant, 20 Milton Street, Canterbury	110.00	"	"
Mr Phillip Craig Hopper, 86 Glenisla Drive, Mt Martha	144.00	"	15/03/99
Mr Robert Peter Jenkins, 9 Highland Road, Faulconbridge, NSW	660.00	"	11/08/99
Mr Rowan David Nankivell, 2 Acacia Rd, Maida Vale, WA	154.00	"	"
Mr Robert Lyons Pearce, 41 Boscombe Avenue, City Beach, WA	770.00	"	11/08/99
Est Mr Peter John Quinlivan, 16 Main Rd, Hepburn Springs	198.00	"	"
Est Mr Peter John Quinlivan, 16 Main Rd, Hepburn Springs	162.00	"	15/03/99

Mr Christopher John Robinson & Mrs Cathrine Mary Robinson, Cottle Road, R D 3 Te Awamutu, New Zealand	170.50	”	11/08/99
Mr Christopher John Robinson & Mrs Cathrine Mary Robinson, Cottle Road, R D 3 Te Awamutu, New Zealand	139.50	”	15/03/99
Mrs Sharon Denise Silver, 2/7 Verney Street, Caloundra, Qld	154.00	”	11/08/99
Ms Tanbara Simpson, C/- Lot 3, Old South Road, Bowral NSW	156.75	”	”
Ms Tanbara Simpson, C/- Lot 3, Old South Road, Bowral NSW	128.25	”	15/03/99
Mr Kevin Ernest Wale & Mrs Marilyn Joy Wale, 18 Peirce Road, Singapore 248534 Singapore	330.00	”	11/08/99
Mr Lyall Henry Watts, 12/823 Rathdowne St, Carlton North	154.50	”	31/03/99
Mr Lyall Henry Watts, 12/823 Rathdowne St, Carlton North	900.00	”	15/03/99
Mr Lyall Henry Watts, 12/823 Rathdowne St, Carlton North	1,100.00	”	11/08/99
Mr Lyall Henry Watts, 12/823 Rathdowne St, Carlton North	154.50	”	30/09/99

01112

CONTACT: MARY BLACKBURN, PHONE: (03) 9615 9837.

Unclaimed Moneys Act 1962

Register of Unclaimed Moneys held by the —

<i>Name of Owner on Books and Last Known Address</i>	<i>Total Amount Due to Owner</i>	<i>Description Of Unclaimed Money</i>	<i>Date when Amount first became Payable</i>
J B WERE CAPITAL MARKETS LIMITED			
\$			
Ark Nominees Pty Ltd, “C D Davis Settlement A/C”, 1 Torresdale Road, Toorak	1,631.96	Cheque	30/09/99
Callig Pty Ltd, “Callig Pty Ltd Super A/C”, PO Box 507, Geraldton, WA	463.73	”	31/03/99
Callig Pty Ltd, “Callig Pty Ltd Super A/C”, PO Box 507, Geraldton, WA	466.27	”	30/09/99
Mrs Sybil Patricia Clifford, Unit 150, Glenaeon Retirement Village, Glenaeon Avenue Belrose NSW	1,134.75	”	31/03/99
Mrs Sybil Patricia Clifford, Unit 150, Glenaeon Retirement Village, Glenaeon Avenue Belrose NSW	1,141.00	”	30/09/99
Ms Elizabeth Scott Coombe, “E S Coombe Super A/C”, GPO Box 814, Adelaide, SA	233.14	”	”
Mr Anthony Edgar Dolin, 11 Lucerne Gardens Edgewater WA	291.42	”	”

Mr Anthony Edgar Dolin, 11 Lucerne Gardens Edgewater WA	289.83	”	31/03/99
Field Bricklaying Pty Ltd, “Field Super Fund A/C”, 9 Malvern Place, Robina, Qld	119.81	”	”
Field Bricklaying Pty Ltd, “Field Super Fund A/C”, 9 Malvern Place, Robina, Qld	120.14	”	30/09/99
Mr David Kirk, PO Box 2191 Lae, Papua New Guinea	156.51	”	31/03/99
Mr David Kirk, PO Box 2191 Lae, Papua New Guinea	157.36	”	30/09/99
Mr Kiernan Patrick Liston & Mrs Florence Anne Hayes, “Kiernan Liston S/F A/C”, PO Box 3128, Murrumbeena	122.99	”	03/09/99
Lutana Holdings Pty Ltd, “Shalders Family A/C”, 22 Weston Way, Kardinya, WA	116.57	”	30/09/99
Mrs Bridget Montgomery, 70 William Street, Balaclava	233.14	”	”
Mrs Ferdinanda Reymers, Unit 8, 170 Gordon Street, Coburg	349.71	”	”
Sandhurst Trustees Ltd, “Timbeck Charitable A/C”, PO Box 175, Ballarat	761.50	”	30/06/99
Mr Frederick Shenstone, “Est Fordyce E Shenstone A/C”, PO Box 404, Wairoonga, NSW	1,128.15	”	”
Mr Richard Hunter Smith & Mrs Fiona Louise Smith, “Superannuation Fund A/C”, 18 Staniland Avenue, Malvern	491.97	”	03/09/99
Mrs Bronwyn Noel Stewart, “Bronwyn Noel Superfund A/C”, C/- Quendan Pty Ltd, 22 Parry Street, Claremont, WA	116.57	”	30/09/99

01113

CONTACT: MARY BLACKBURN, PHONE: (03) 9615 9837.

Unclaimed Moneys Act 1962

Register of Unclaimed Moneys held by the —

<i>Name of Owner on Books and Last Known Address</i>	<i>Total Amount Due to Owner</i>	<i>Description Of Unclaimed Money</i>	<i>Date when Amount became Payable</i>
JOE WHITE MALTINGS LIMITED			
	\$		
Mr B. D. Vedova, Albany Road, Gosnells, WA	499.18	Cheque	27/04/2000
Mr A. Hazard, P.O. Box 167, Double Bay, NSW	170.50	”	”
Miss C.A. Gailey, 15/175 Greenwich Rd, Greenwich, NSW	116.77	”	”
Natural Fibre P/L, C/- Tony Pagano, Level 13, Septimus Roe Square, 256 Adelaide Terrace, Perth, WA	195.25	”	”

01097

CONTACT: Mr TONY TARQUINIO, PHONE: (03) 9419 7411.

Unclaimed Moneys Act 1962

Register of Unclaimed Moneys held by the —

<i>Name of Owner on Books and Last Known Address</i>	<i>Total Amount Due to Owner</i>	<i>Description Of Unclaimed Money</i>	<i>Date when Amount first became Payable</i>
OAMPS LIMITED			
	\$		
Graham Roy Andrewartha & Sandra Andrewartha, 27 Knapman Street, Port Pirie ,SA	395.00	Cheque	10/12/98
Graham Roy Andrewartha & Sandra Andrewartha, 27 Knapman Street, Port Pirie, SA	395.00	"	29/10/99
Bemoa Pty Ltd, "A/C Barry Petroleum", PO Box 188, Fyshwick, ACT	550.00	"	"
Estate Bob Butler, 2815 N 52nd Street, Unit #18 Phoenix, Arizona 85008, United States of America	366.00	"	"
Paul Carter, C/- The Dunlap Agency Inc, Suite 203, 1305 21st Avenue Fairbanks, Alaska 99701, USA	100.00	"	10/12/98
Paul Carter, C/- The Dunlap Agency Inc, Suite 203, 1305 21st Avenue Fairbanks, Alaska 99701, USA	100.00	"	29/10/99
Castleberry's Inc, PO Box 617, Clinton NC 28328, USA	153.90	"	10/12/98
Emijab Pty Ltd, 79 Salamander Way, Salamander Bay, NSW	140.00	"	29/10/99
Emijab Pty Ltd, 79 Salamander Way, Salamander Bay, NSW	140.00	"	10/12/98
Englefield Inc, 447 James Parkway, Newark Ohio USA 43055	884.65	"	"
Englefield Inc, 447 James Parkway, Newark Ohio USA 43055	884.65	"	29/10/99
Federated Transport Inc, PO Box 617, Clinton NC 28328, USA	153.90	"	10/12/98
Mr Daniel Hargraves, C/- Costigan & Burns, 6 Harrison Street, New York 10013, USA	250.00	"	29/10/99
HB Williams Inc, C/- Christian Weber Jr, PO Box 23, Palmyra NJ 08065, USA	1,961.60	"	"
HB Williams Inc, C/- Christian Weber Jr, PO Box 23, Palmyra NJ 08065, USA	1,961.60	"	10/12/98
Hibe Pty Ltd, "A/C Central West Petroleum", PO Box 175, Orange NSW	115.00	"	"
Hill Fuel Transport Pty Ltd, 22 Kanandah Road, Broken Hill, NSW	237.50	"	29/10/99
Hill Fuel Transport Pty Ltd, 22 Kanandah Road, Broken Hill, NSW	237.50	"	10/12/98
J & C Levesque Pty Ltd, 47 Witt Street, Yarrawonga	140.00	"	"
J & C Levesque Pty Ltd, 47 Witt Street, Yarrawonga	140.00	"	29/10/99
Mr Harold D Jones, 273 Dunn Road, Norway Maine 04268, United States of America	384.65	"	"
JS Commens Pty Ltd, 4 Harley Avenue, Mt Victoria, NSW	515.00	"	10/12/98

JS Commens Pty Ltd, 4 Harley Avenue, Mt Victoria, NSW	515.00	''	29/10/99
Kenney Webber & Lowell, 200 302 West Main Street, Avon CT 06001 USA	125.00	''	10/12/98
Kenney Webber & Lowell, 200 302 West Main Street, Avon CT 06001 USA	125.00	''	29/10/99
Lower Norton Pty Ltd, PO Box 106, Torquay	285.00	''	10/12/98
Lower Norton Pty Ltd, PO Box 106, Torquay	285.00	''	29/10/99
Thomas A Hamlin, Md 6410 Fannin/Suite 932, Houston Tx 77030 USA	461.60	''	''
Geoffrey Stewart Moreland, "A/C Morland Family Trust", PO Box 3258, Logenholme	500.00	''	10/12/98
Geoffrey Stewart Moreland, "A/C Morland Family Trust", PO Box 3258, Logenholme	500.00	''	29/10/99
Nl & Ri Wirth Pty Ltd, PO Box 888, Naracoorte, SA	165.00	''	10/12/98
Nl & Ri Wirth Pty Ltd, PO Box 888, Naracoorte, SA	165.00	''	29/10/99
Pj Moran Pty Ltd, PO Box 21, South Grafton, NSW	210.00	''	''
RCW Pty Ltd, Box 367, Warragul	237.50	''	''
RCW Pty Ltd, Box 367, Warragul	237.50	''	10/12/98
Sampson-Bladen Oil Company Inc, C/- Rogers Clark, Highway 421, North Clinton NV 28328, USA	153.80	''	''
William G Sortor, 50 Parkhill Road, Hannington Park, NJ 07640, USA	1,000.00	''	29/10/99
William G Sortor, 50 Parkhill Road, Hannington Park, NJ 07640, USA	1,000.00	''	10/12/98

01114

CONTACT: MARY BLACKBURN, PHONE: (03) 9615 9837.

Unclaimed Moneys Act 1962

Register of Unclaimed Moneys held by the —

<i>Name of Owner on Books and Last Known Address</i>	<i>Total Amount Due to Owner</i>	<i>Description Of Unclaimed Money</i>	<i>Date when Amount first became Payable</i>
ORICA LIMITED			
	\$		
Est Judith Allen, C/- Patrick J Daly & Co, 5-7 Havilah Street, Chatswood, NSW	150.00	Cheque	02/07/99
Aus Holdings Pty Ltd, "Superannuation A/C", 7/79 Macpherson Street, Bronte, NSW	101.50	''	18/12/98
Mr John Bruce Bingeman & Mrs Susan Bingeman, "Bingeman Super Fund A/C", PO Box 711, Lilydale	146.00	''	''
Mr John Bruce Bingeman & Mrs Susan Bingeman, "Bingeman Super Fund A/C", PO Box 711, Lilydale	104.05	''	02/07/99
Ms Heather Janet Blyth, 22 Hayes Street, Northcote	118.32	''	18/12/98
Mr Peter R C Brown, 60 Cammel Road, Ferndown, Wimbourne Dorset Bh22 8sb U K	195.19	''	02/07/99

Mr Peter R C Brown, 60 Cammel Road, Ferndown, Wimbourne Dorset Bh22 8sb U K	352.49	''	18/12/98
Mr Roger William Brown, PO Box 5, Lyneham, ACT	171.60	''	02/07/99
Mr Roger William Brown, PO Box 5, Lyneham, ACT	241.27	''	18/12/98
Mrs Bessie M Bryden, 19/1 Rita Street, Mount Maunganui, New Zealand	373.20	''	''
Mrs Bessie M Bryden, 19/1 Rita Street, Mount Maunganui, New Zealand	206.66	''	02/07/99
Ms Margaret J Buckley, 18 Lansell Road, Toorak, Melbourne	268.65	''	''
Business Excellence Pty Ltd, "Superannuation Fund A/C", PO Box 432, Newport Beach, NSW	212.70	''	''
Cadzow Pty Ltd, 23 Peacock Parade, Frenchs Forest, NSW	508.50	''	02/07/99
Cadzow Pty Ltd, 23 Peacock Parade, Frenchs Forest, NSW	983.10	''	18/12/98
Ms Sharon Maree Carey & Mr Martin John Carey, "Kegworth Super Fund A/C" 12 Kegworth Street, Leichhardt, NSW	105.00	''	02/07/99
Ms Sharon Maree Carey & Mr Martin John Carey, "Kegworth Super Fund A/C" 12 Kegworth Street, Leichhardt, NSW	203.00	''	18/12/98
Carmtone Investments Pty Ltd, Everton House, 1 Everton Road, Faulconbridge, NSW	114.84	''	''
Mr Bruce Chalker, 3/78 Eyre Street, North Ward, Qld	1,609.35	''	02/07/99
Mr Bruce Chalker, 3/78 Eyre Street, North Ward, Qld	3,111.41	''	18/12/98
Mr Leroy Chalker & Mrs June Chalker, 124 Darlington Road, N E Warren Ohio 44484 USA	323.16	''	''
Ms Shook Cheng Chong, 18/2 Edensor Street, Epping, NSW	255.00	''	02/07/99
Ms Shook Cheng Chong, 18/2 Edensor Street, Epping, NSW	493.00	''	18/12/98
Christian Nominees Pty Ltd, PO Box R1577, Royal Exchange, NSW	232.00	''	''
Christian Nominees Pty Ltd, PO Box R1577, Royal Exchange, NSW	120.00	''	02/07/99
Mrs Ina Amy Clark, C/- Roy Holbrook Bleakleys Limited, PO Box 1237, Camberwell	106.35	''	''
Miss Judith A Clarke, C/- PO Box 28290, Remuera, Auckland 5, New Zealand	365.31	''	18/12/98
Miss Judith A Clarke, C/- PO Box 28290, Remuera, Auckland 5, New Zealand	202.29	''	02/07/99
Mr Paul Condell, Cmc GPO Box 560, Suva, Fiji	232.00	''	18/12/98
Ms Christine Mary Cussen, 9 Shellbank Parade, Cremorne, NSW	136.95	''	02/07/99
D C McMillan (Lochaber) Ltd, C/- H Russell Fountain, PO Box 12, Christchurch 1 New Zealand	100.46	''	''
D C McMillan (Lochaber) Ltd, C/- H Russell Fountain, PO Box 12, Christchurch 1 New Zealand	181.42	''	18/12/98
Mrs Anna V Dellanoce, "Westwood", Heatherlands Rd, Chilworth Hants, United Kingdom	104.52	''	''
Ecliptic Pty Ltd, Suite 2, 191 Riversdale Road, Hawthorn	480.53	''	''
Ecliptic Pty Ltd, Suite 2, 191 Riversdale Road, Hawthorn	248.55	''	02/07/99
Mr Terrence Edward Ewing, PO Box 39, Sandy Bay, Tas.	171.68	''	18/12/98
Mr Gin Soon Foo, 3 Farrington Road, Leeming, WA	226.53	''	''

Mr Bryan G P Audhlam-Gardiner, 15 Terrington Hill, Marlow Buckingham, United Kingdom	170.82	''	''
Mr Douglas W Gardiner Yateley, 3 Yar Orrong Rd, Toorak	211.40	''	02/07/99
Mr Simon Gill & Mr Jeremy Gill & Mr Andrew Gill, 'Waterloo', Narromine, NSW	130.50	''	18/12/98
Mr Timothy Rhys Grabrovaz, 1/22 Anderson Street, Belmore, NSW	116.00	''	''
Dr Anna Granger 130a, Wolseley Rd, Point Piper, NSW	106.95	''	''
Mrs Valerie E Greene C/- Mr John C M Grant, 1 Pullenvale Road, Pullenvale, Qld	829.11	''	''
Mrs Valerie E Greene C/- Mr John C M Grant, 1 Pullenvale Road, Pullenvale, Qld	428.85	''	02/07/99
Mr Nicholas Grenfell, 29 Fairdale Gardens, Putney, London S W 15 United Kingdom	160.96	''	18/12/98
Ms Phyllis Heathershaw Grey, 2 Morseby Street, Canterbury	210.25	''	''
Mr Christopher Havers, 10 Abelia Rise, Narre Warren	116.00	''	''
Mr John Stuart Hines, 54 Groom Street, Hughes, ACT	104.25	''	02/07/99
Mr Henry Frederick Hopkins, 5 Loloma Court, Burwood	396.79	''	18/12/98
Mr Henry Frederick Hopkins, 5 Loloma Court, Burwood	282.50	''	02/07/99
Mr Terrance Hulme, 2/78-84 Auburn Road, Hawthorn	119.50	''	18/12/98
Mr Paul Hurley, "Boona Two Unit Fund A/C", 1 Glenmoyne Square, Werribee	106.35	''	02/07/99
Mr Vi Huu Huynh, 48 Calder Road, Darlington, NSW	176.32	''	18/12/98
Mr Laurence Melville Iffla, 8 Walter Street, Claremont, WA Joined Up Thinking Pty Ltd, "Blampied A/C", 34 Billyard Avenue, Elizabeth Bay, NSW	119.50	''	''
Miss Margaret F Kelley, Flat 1, 27 Kensington Road, South Yarra	118.95	''	02/07/99
Mrs May Kidd, A/C No 215-1115568 State Bank, 168 Chapel Street, Prahran	117.45	''	''
Mrs May Kidd, A/C No 215-1115568 State Bank, 168 Chapel Street, Prahran	165.17	''	18/12/98
Mr Maciej Julian Labuda, 21 Henry Street, Cook, ACT	116.00	''	''
Johannes La Grouw, C/- La Grouw Corporation, Private Bag 3034, Rotorua, New Zealand	136.50	''	02/07/99
Mrs Clarice M Layne, 20 Osborne Ave, Mckinnon	2,763.99	''	18/12/98
Mrs Clarice M Layne, 20 Osborne Ave, Mckinnon	1,429.65	''	02/07/99
Lelor Pty Ltd, 53 Severn Crescent, Rowville	137.75	''	18/12/98
Flt Lt Brian J Maher, Hardham Gate, Coldwaltham, Pulborough, West Sussex Rh20 1ld, United Kingdom	120.78	''	''
Mr Angus Campbell McKechnie, 15/449 St Kilda Road Melbourne	225.00	''	02/07/99
Mr Angus Campbell McKechnie, 15/449 St Kilda Road Melbourne	435.00	''	18/12/98
Microtech Security Control Pty Ltd, "Jason Patterson Super/F A/C", 5/10 Hoddle Street, Abbotsford	120.00	''	02/07/99
Ms Colleen Elizabeth Mitchell, 40 Hammond Way, Kelso, Qld	118.32	''	18/12/98
Mr Eigil Nielsen, Level 19, 20 Bond Street, Sydney, NSW	170.15	''	02/07/99
Ms Raj Parmar, PO Box 492, Neutral Bay, NSW	108.40	''	18/12/98
Mr Colin Gerald Phillips & Mrs Carol Anne Phillips, 12 Dural Crescent, Engadine, NSW	150.00	''	02/07/99
Dr Andrew Edward Prendergast, 326 Drummond Street, Carlton	116.00	''	18/12/98
Raceport Pty Limited, Attn Richard Beck, Suite 404, 140 Sussex Street, Sydney, NSW	531.75	''	02/07/99

Mrs Lucille Reubens, 79 Rutland Avenue, Mount Eliza	778.50	''	''
Mr Glen Frank Richards & Ms Kerrie Sandra Richards, "Richards Super Fund A/C", C/- London Partners Pas, PO Box 748, West Perth, WA	150.00	''	''
Ms Leanne Marie Ross, 2/4 Banks Road, Cranbourne	116.00	''	18/12/98
Mr George Rossengas, 51 Rockebear Grove, Ivanhoe	150.00	''	02/07/99
Mr George Rossengas, 51 Rockebear Grove, Ivanhoe	290.00	''	18/12/98
Mr Robert Salt, 11b/23 Thornton Street, Darling Point, NSW	145.00	''	''
Mr David Hayes Small, 13 Chatswood Avenue, Chatswood, NSW	145.00	''	''
Mrs Natalie P Smith & Mrs Noelene M McIlroy & Mr Oliver R Matson, C/- PO Box 4341, Christchurch, NZ	505.87	''	02/07/99
Mr Michael Robert Staindl, 7 Mason Street, Hawthorn	149.35	''	18/12/98
Mr Michael Robert Staindl, 7 Mason Street, Hawthorn	106.35	''	02/07/99
Mrs Bronwyn Noel Stewart, 22 Darry Street, Claremont, WA	145.00	''	18/12/98
Est Edris Jean Sullivan, C/- Cheney & Green, PO Box 139, Indooroopilly, Qld	172.55	''	''
Mr John I Sullivan, Box 35, Caulfield South	132.90	''	02/07/99
Mr John I Sullivan, Box 35, Caulfield South	186.82	''	18/12/98
Mr Geoffrey Norman Francis Taylor, 302 Moore Park Road, Paddington, NSW	122.85	''	02/07/99
Mrs Elsie Mary Thompson, C/- B Knowles Ernst & Young, GPO Box 2646, Sydney, NSW	1,500.00	''	''
Mrs Lindsay G Verdin, PO Box 75, Indooroopilly, Qld	184.44	''	18/12/98
Vivacity (Wa) Pty Ltd, "Vivacity Super Fund A/C", Unit 3, 252 South Street, Hilton, WA	106.35	''	02/07/99
Wairenga Nominees Ltd, 'Lyndor' Lee, Pakaraka Road, Rd 6 Masterton 5921, New Zealand	130.49	''	''
Mr Paul W Walker & Alexander W Filby, Decd, Dinmor Walker Place, Church Point, NSW	102.89	''	18/12/98
Estate James Walsh, C/O Mr Douglas B Rope, Glenmore Rd, Pakaronga, New Zealand	129.66	''	''
Mr John Douglas Watt & Mrs Deborah Louise Watt, "DI Watt Super Fund A/C", 146 Wallumatta Road, Newport, NSW	119.50	''	''
Estate Dorothy L Wells, C/- Mr A Wells, 11 Thomas Street, Strathfield, NSW	505.18	''	''
Miss Anna Louise Westacott, C/- Whitelaw & Gove, 4/500 Collins Street, Melbourne	214.65	''	02/07/99
Prof John William White & Mrs Ailsa Barbara White, 2 Spencer Street, Turner ACT	123.25	''	18/12/98
Mr Ralph Rhys Williams, 2 Ailsa Avenue, Malvern East	145.00	''	''
Mr John William Willis, 12 Misan Drive, Morphett Vale, SA	118.32	''	''
Mr John Alistair Wood, 14 Louisa Court, Emerald, Qld	116.00	''	''
Mrs Joan M Woodbury, 15 Adsett Street, Taringa, Qld	116.18	''	''
Mrs Baoqin Wu, 59 Hillview Avenue, Mount Waverley	142.50	''	02/07/99

01115

CONTACT: MARY BLACKBURN, PHONE: (03) 9615 9837.

Unclaimed Moneys Act 1962

Register of Unclaimed Moneys held by the —

<i>Name of Owner on Books and Last Known Address</i>	<i>Total Amount Due to Owner</i>	<i>Description Of Unclaimed Money</i>	<i>Date when Amount first became Payable</i>
TWEED SUTHERLAND FIRST NATIONAL REAL ESTATE			
	\$		
Mr Curtis	186.00	Cheque	11/09/95
01126 CONTACT: C. C. TWEED, PHONE: (SALES DEPARTMENT) (03) 5442 1811. (RENTAL DEPARTMENT) (03) 5442 1445.			

Unclaimed Moneys Act 1962

Register of Unclaimed Moneys held by the —

<i>Name of Owner on Books and Last Known Address</i>	<i>Total Amount Due to Owner</i>	<i>Description Of Unclaimed Money</i>	<i>Date when Amount first became Payable</i>
UBS WARBURG – PRIVATE CLIENTS LTD			
	\$		
Mr R H Johnsen, 5 Bellaire Court, Toorak	105.00	Cheque	13/11/95
Snobane Pty Ltd, 647 Murray Street, West Perth, W	478.85	"	23/10/97
Ms V L Collinson, Unit 1, 83 Cabramatta Road, Mosman, NSW	139.30	"	08/01/96
Mr P Grant, PO Box 6178, Baulkham Hills, NSW	184.70	"	28/11/97
Mr R Dietz, 9 Bimini Court, Clear Island Waters, Qld	463.30	"	24/07/96
Mr Steve Erdelyi, c/- Falcon, 1900 West Loop South, Suite 1800, Houston, Tx USA	255.40	"	20/10/98
Nelson Amber Pacific Pty Limited, PO Box 190, Rosebud ABN Amro Bank Dubai, Attn: George Raju, PO Box 2567, Dubai United Arab Emirates	101.57	"	"
BBMB Securities SDN BHD, Level 2 & 3, Plasa Raja Chulan, No 8 Jalan Raja Chulan	425.00	"	05/05/98
50200 Kuala Lumpur Malaysia	418.54	"	28/08/98
Garro Nominees Pty Ltd, Ground Floor, 377 Lonsdale Street, Melbourne	320.05	"	23/05/95
McIntosh Securities Limited, Level 42/120 Collins Street, Melbourne	120.00	"	17/02/95
Mr J L N Aitken, 25 Fitzwilliam Road, Vacluse, NSW	6,217.80	"	15/01/98
Mr John Collis Barry, C/- Challenger Int Ltd, Level 43, Amp Centre, 50 Bridge Street, Sydney. NSW	150.00	"	27/11/97

<i>Victoria Government Gazette</i>	<i>G 17</i>	<i>26 April 2001</i>	<i>733</i>
Mrs A Kadriye, C/- PO Box 290, Brunswick Bellseed Pty Limited,	174.50	”	07/06/96
Lot D, Richmond Road, Dean Park, NSW BNP Securities Ltd, Est-Ouest,	190.90	”	21/09/95
24 Boulevard Princesse Charlotte, Mc 98000, Monaco Pental Nominees Pty Limited,	439.78	”	01/02/95
Level 15, the Chifley Tower, 2 Chifley Square, Sydney, NSW	1,162.50	”	26/07/96
Tower Life Australia, 80 Alfred Street, Milsons Point, NSW	2,375.00	”	13/07/95

01135

CONTACT: HEATHER MICHALUK, PHONE: (03) 9242 6115.

Unclaimed Moneys Act 1962

Register of Unclaimed Moneys held by the —

<i>Name of Owner on Books and Last Known Address</i>	<i>Total Amount Due to Owner</i>	<i>Description Of Unclaimed Money</i>	<i>Date when Amount first became Payable</i>
YARRA VALLEY WATER LTD			
	\$		
18 McConchie Avenue Pty Ltd, 18 McConchie Avenue, Kew East	168.89	Cheque	13/12/99
745 Burwood Road Pty Ltd, C/O Warick A. Leeming, Level 26, 120 Collins Street, Melbourne	565.65	”	27/08/99
A & A Wong Nominees Pty Ltd, C/O Andy Kala R/E Pty Ltd, 189 Middleborough Road, Box Hill	134.63	”	17/02/00
Addison Pty Ltd, C/- Silver Thomas Hanley, 3 Glenarm Road, Glen Iris	149.55	”	15/12/99
Advantage Credit Union, PO Box 5341 Bb Melbourne	139.71	”	17/05/99
Alliswell Pty Ltd, C/O Myles Snow & Associates, Level 3, 100 Dorcas Street, South Melbourne	738.40	”	30/07/99
Alliswell Pty Ltd, C/O Myles Snow & Assoc., Level 3, 100 Dorcas Street, South Melbourne	377.40	”	”
Alliswell Pty Ltd, C/O Myles Snow & Assoc., Level 3, 100 Dorcas Street, South Melbourne,	239.80	”	”
Alliswell Pty Ltd, C/O Myles Snow & Associates, Level 3, 100 Dorcas Street, South Melbourne	191.82	”	”
Alliswell Pty Ltd, C/O Myles Snow & Assoc., Level 3, 100 Dorcas Street, South Melbourne	167.09	”	”
Alliswell Pty Ltd, Myles Snow & Associates, Level 3, 100 Dorcas Street, South Melbourne	162.55	”	28/07/99
Alliswell Pty Ltd, C/O Myles Snow & Associates, Level 3, 100 Dorcas Street, South Melbourne	160.85	”	30/07/99
Alliswell Pty Ltd, C/O Myles Snow & Assoc., Level 3, 100 Dorcas Street, South Melbourne	150.25	”	”

Alliswell Pty Ltd, C/O Myles Snow & Assoc., Level 3, 100 Dorcas Street South Melbourne	138.98	''	''
Alliswell Pty Ltd, C/O Myles Snow & Assoc., Level 3, 100 Dorcas Street South Melbourne	133.90	''	''
Alliswell Pty Ltd, C/O Myles Snow & Assoc., Level 3, 100 Dorcas Street South Melbourne	129.68	''	''
Alliswell Pty Ltd, C/O Miles Snow & Assoc., Level 3 100 Dorcas Street South Melbourne	103.57	''	''
Aluminium Specialties Pty Ltd, 108 Toongabbie Road, Toongabbie NSW	371.53	''	23/11/99
Ampol Petroleum Victoria Pty Ltd, GPO Box 3916 Sydney NSW	475.44	''	15/09/99
ANZ Life Assurance Co Ltd, Unit 1, 814-818 Whitehorse Road, Box Hill	350.75	''	22/12/99
ANZ Life Assurance Co Ltd, Unit 1, 814-818 Whitehorse Road, Box Hill	348.50	''	''
ANZ Life Assurance Co Ltd, Unit 1, 814-818 Whitehorse Road, Box Hill	231.05	''	''
ANZ Life Assurance Co Ltd, Unit 1, 814-818 Whitehorse Road, Box Hill	166.30	''	''
ANZ Life Assurance Co Ltd, Unit 1, 814-818 Whitehorse Road, Box Hill	154.25	''	''
ANZ Life Assurance Co Ltd, Unit 1, 814-818 Whitehorse Road, Box Hill	144.95	''	''
ANZ Life Assurance Co Ltd, Unit 1, 814-818 Whitehorse Road, Box Hill	137.75	''	''
ANZ Life Assurance Co Ltd, Unit 1, 814-818 Whitehorse Road, Box Hill	118.10	''	''
ANZ Life Assurance Co Ltd, Unit 1 814-818 Whitehorse Road Box Hill	110.35	''	''
ANZ Life Assurance Co Ltd, Unit 1, 814-818 Whitehorse Road, Box Hill	110.35	''	''
ANZ Life Assurance Co Ltd, Unit 1, 814-818 Whitehorse Road, Box Hill	103.45	''	''
ANZ Life Assurance Co Ltd, Unit 1, 814-818 Whitehorse Road, Box Hill	102.10	''	''
Artquest Pty Ltd & Others, Teska Carson Pty Ltd, PO Box 4192 Richmond	467.49	''	30/11/99
Artquest Pty Ltd & Others, Teska Carson Pty Ltd, PO Box 4192 Richmond	105.15	''	02/12/99
Australand Holdings Pty Ltd, 15 Business Park Drive, Notting Hill	189.99	''	23/09/99
Australand Holdings Pty Ltd, 15 Business Park Drive, Notting Hill	189.99	''	21/09/99
Australand Holdings Pty Ltd, 15 Business Park Drive, Notting Hill	101.30	''	05/11/99
Avonwood Homes Pty Ltd, Unit 3, 261 Princes Highway, Hallam	188.65	''	06/01/00
Bank of Melbourne-Property Dept, C/O Westpac Property Services, GPO Box 4180 Sydney, NSW	195.55	''	15/09/99
Batsanis Properties Pty Ltd, Unit 1, 5 Macquarie Drive, Thomastown	101.70	''	25/08/00

Boulderwood Pty Ltd, 133 Wheatsheaf Road, Glenroy	386.60	''	13/01/00
BHP Co Ltd, Melbourne Research Labs, 245 Wellington Road, Mulgrave	150.00	''	11/02/00
Body Corp Strata Plan No Rp9005, 94 McMahon Road, Reservoir	375.90	''	19/08/99
Bravado Property Investments Pty Ltd, 21 Glasgow Avenue, Reservoir	109.18	''	10/11/99
Brentwood Homes Pty Ltd, 51 Clow Street, Dandenong	169.05	''	13/09/99
Burwood Nominees Pty Ltd, 623-625 High Street, South Kew	121.85	''	14/10/99
Calmanay Nominees Pty Ltd, Level 10, Jetset Center 5 Queens Road, Melbourne	118.10	''	21/01/00
Caltex Oil Australia (Aust) Pty Ltd, PO Box 760g, Melbourne	100.75	''	10/06/99
Cambridge Developments, 27 Glenroy Road, Hawthorn	154.31	''	14/09/99
Cameron & Jason Holdings Pty Ltd, 101 New Road, Oak Park	150.40	''	18/06/99
Christalin Investments Pty Ltd, 38 Lindsay Street, Bulleen	199.00	''	01/03/99
Cloverbrook Pty Ltd, 136 Glenferrie Road, Malvern	125.35	''	24/09/99
Como Constructions Pty Ltd, Level 7, 1 Princess Street, Kew	107.40	''	06/12/99
Concept Powder Coaters, PO Box 86, Camberfield	191.05	''	13/10/99
Cotham Investments Pty Ltd, 165 Victoria Parade, Collingwood	102.45	''	04/10/99
Dadbirth Pty Ltd, C/O Morry Frid Group Pty Ltd. Po Box 40 Caulfield South	108.52	''	26/05/99
Dartone Pty Ltd, 1101 Whitehorse Road, Box Hill	122.05	''	02/06/99
David McNamara & Maree McNamara, Rmb 1540, Kyvalley	102.75	''	06/08/99
David Riordan, 346 George Street, Doncaster	191.70	''	03/08/99
Dewin, P L, 37 Mockridge Drive, Mill Park	269.57	''	30/08/99
Dr G H F Tai, 22 Diosma Drive, Glen Waverley	148.03	''	20/05/99
E & V Investments Pty Ltd, 77 Ingrams Roa Eltham	107.39	''	06/04/99
Ebdon Group Pty Ltd, 2 Weron Court, Vermont	113.83	''	05/07/99
Edward Lee Nominees Pty Ltd, 46 Rocklea Road, Bulleen	139.93	''	02/08/99
Eirus Pty Ltd, 10 Marshall Avenue, Kew	180.15	''	06/02/00
Eltham Developments Pty Ltd, 525 Mount Pleasant Road, Research	1,404.88	''	05/07/99
Estate of H L Moss, C/O Equity Trustees, 472 Bourke Street, Melbourne	220.50	''	05/11/99
Estate of J J McCallum, C/O State Trustee, 168 Exhibition Street, Melbourne	163.55	''	28/02/00
Ferron Industries Pty Ltd, C/O The Secretary, PO Box 306, Sunbury	136.90	''	26/10/99
Filshare Pty Ltd, 10b Hillcroft Drive, Templestowe	142.65	''	28/02/00
Flystar Pty Ltd, PO Box 2289, Caulfield Junction	123.23	''	25/08/99
Franje Nominees Pty Ltd, Frank J. Horvat & Co, PO Box 196, Glenroy	101.00	''	23/09/99
Furina Pty Ltd & Others, 5-7 Theobald Street, Thornbury	148.95	''	10/08/99
G T L Nominees Pty Ltd & D & M Grundmann, C/O Michelle Sagg, 8 Campbell Street, Bowen Hills, Qld	598.09	''	08/02/00
Galoray Pty Ltd, 68 Duff Parade, View Bank	157.13	''	18/01/00

Georgeland Pty Ltd, 39 George Street, Diamond Creek	164.85	''	29/12/99
Gerasimos Theodorakakos, Unit 1, 3 Corhampton Road, Balwyn North	240.85	''	06/08/99
Gutman Nominees Pty Ltd, C/O Mulberryhill Pty Ltd, 1078 High Street, Armadale	136.11	''	01/06/99
H & S Ebrahim, 147 High Street, Thomastown	230.10	''	27/04/99
H Hanna & Co Pty Ltd, 64 Trenerry Crescent, Abbotsford	1,412.02	''	09/08/99
Handevel Pty Ltd, Shop 604, Waverley Gardens, Mulgrave	188.36	''	15/07/99
Hoppe Pty Ltd, Level 3, 766 Elizabeth Street, Melbourne	135.05	''	20/05/99
Ilinvale Pty Ltd, Shop 1, 7 Hamilton Place, Mount Waverley	117.35	''	31/01/00
J. Bourke, K O'Brien, E. Mahney, N. Schmidt, 27 Wooddale Grove, Mitcham	190.50	''	08/10/99
J L B Investments Pty Ltd, 21 Boyd Street, Warrandyte	264.00	''	05/07/99
Jacarla Pty Ltd, 33 Baldwin Avenue, Montmorency	124.40	''	08/02/00
Jenola Lodge Pty Ltd, Unit 2, 472-86 Waverley Road, Malvern East	198.94	''	06/08/99
Kentucky Fried Chicken, Cnr Dorest, Croydon	267.84	''	30/06/99
Kooyong Enterprises Pty Ltd, 2 Lyric Court, Ringwood North	107.85	''	20/08/99
Leaseway Pty Ltd, C/O McPherson Real Estate P/L, 321 Camberwell Grove, Camberwell	155.28	''	23/08/99
Lecce Nominees Pty Ltd, 3 Craig Court, Chirnside Park	546.55	''	18/01/00
Leinad Investments Pty Ltd, 1537-1549 Sydney Road, Campbellfield	226.55	''	01/09/99
Lifetime Homes Pty Ltd, 71 Durham Road, Surrey Hills	105.05	''	23/07/99
Mardom Nominees Pty Ltd, C/O Mc Gees, 455 Bourke Street, Melbourne	170.70	''	01/09/99
Mersco Pty Ltd, 29-31 Keysborough Street, Keysborough	108.22	''	02/08/99
Messrs J & F McCooey, Unit 90, 155 Warrigal Rd, Burwood	109.50	''	08/02/00
Metisse Pty Ltd, T/A Bernini Restorante, 252 Glenferrie Road, Malvern	590.95	''	23/09/99
Milgrove Holdings Pty Ltd, 29-31 Rathdowne Street, Carlton South	287.45	''	20/08/99
Ming Ti Cheah, 16 Jalan SS/31 Taman Mayang 47301 Petaling Jaya Selanger, Singapore, Malaysia 1234	227.57	''	01/12/99
Miss A Day & Mr J Stevens, 25 Woodland Avenue, Croydon	127.30	''	07/01/00
Miss E Russell, C/O Ga Thomson & Co, 633 Sydney Road, Brunswick	197.71	''	15/02/00
Miss J M Leckie, 57 Somers Street, Burwood	115.65	''	22/02/00
Miss K Altmann, 57 Annie Street, New Farm, Qld	128.15	''	14/08/99
Miss U F Harrison, C/ Ms Gourland & Ms Devercelli, 16 Douglas Street, Malvern East	108.50	''	27/10/99
Miss V Womersley & Mr A Parker, 285 Burnley Street, Richmond,	232.05	''	15/09/99
Miss Wendy Anne Crank, 7 Craig Street, Blackburn	216.40	''	02/08/99
Mitcham Panel Service Pty Ltd, 6 Leflan Close, Ringwood	112.82	''	08/09/99
Mobil Oil Aust Ltd, 142-146 Andersonscreek Road, Doncaster East	3,434.00	''	04/10/99
Mr & Mrs R Gosstray, 5 Westley Street, Hawthorn East	119.35	''	12/11/99
Mr A & Mrs Eu Le Luca, 130 Cumberland Rd, Pascoe Vale	176.25	''	01/06/99
Mr A & Mrs G Waterman, Unit 10, 791-795 Point Nepean Road, Rosebud	121.00	''	18/02/00

Mr A & Mrs J Cook, 1 Ashley Court, Reasearch	113.08	''	10/08/99
Mr A B Cox, 3 Coxs Road, Kowloon, Hong Kong	147.96	''	16/08/99
Mr A G Amad, Unit 35, 156 Beaconsfield Parade, Albert Park	123.15	''	20/12/99
Mr A J Hunter, 24 Deschamps Street, Lilydale	114.50	''	26/04/99
Mr A J Maruff, Flat 9, 194 Purinuan Road, Reservoir	133.44	''	10/12/99
Mr A Ng, 30 Wills Street, Kew	199.65	''	15/12/99
Mr Andrew Kavanagh, 2 Castlereagh Court, Mount Waverley	152.52	''	08/09/99
Mr B & Mrs B L Smyth, 2 Guymer Court, Montmorency	131.15	''	25/03/99
Mr B G W & Mrs K J Bowler, 9 Adelaide Street Armadale	109.30	''	03/08/99
Mr B J & Mrs V M Salter, 4 Frank Street, Doncaster	117.40	''	12/08/99
Mr B J Allatt, 1 Orion Court, Lilydale	109.47	''	''
Mr B M Coulter, Flat 1, 10 Severn Street, Balwyn North	107.40	''	27/01/00
Mr B Martin, 7 Crawford Road, Templestowe Lower	144.60	''	30/07/99
Mr B Scardamaglia, 1 Furlong Court, Endeavour Hills	319.95	''	09/09/99
Mr B T O Shannessy, 157 Lynch Road, Fawkner	124.25	''	11/11/99
Mr B W Dharmatilaje, 4 Blau Street, Bundoora	151.00	''	29/12/99
Mr C & Mrs B Pfund, 12 Clontarf Crescent, Templestowe	114.45	''	05/08/99
Mr C I & Mrs S A Bakowski, 8 Ashton Rise, Doncaster East	100.55	''	14/02/00
Mr C J & Mrs J T Stoyles, 105 Point Lonsdale Road, Point Lonsdale	106.90	''	21/05/99
Mr C J & Mrs S J Sykes, 4 Jackson Street, Balgowlah, NSW	137.25	''	04/05/99
Mr C M & Mr T Bodin, 47 Cypress Avenue, Glen Waverley	140.34	''	20/09/99
Mr C Tseng, 107 Landscape Drive, Doncaster East	215.49	''	12/07/99
Mr C Vordonas & Ms G Nikolakopoulos, 143 Keele Street, Collingwood	138.75	''	10/08/99
Mr C W Au & Mrs M L Chong, 5A 10 Cheung Yee Street, Kowloon, Hong Kong	299.10	''	26/08/99
Mr D & Mrs M Silver, PO Box 227, St Kilda	101.75	''	21/02/00
Mr D & Mrs M Visser & Mr S & Mrs G Shepp, 8 Jeanette Maree Court, Kilsyth	229.17	''	01/12/99
Mr D C & Mrs P M Porter, 131 New Street, Brighton	125.73	''	02/09/99
Mr D J & Mrs M J Hoy, 3B Glyndebourne Avenue, Toorak	207.58	''	28/10/99
Mr D M Farrugia, 119 Barrow Street, Coburg	106.15	''	12/07/99
Mr D R & Mrs R A Hentschke, 8 Heatherleigh Place, Malvern East	160.14	''	11/12/99
Mr D Raper, 55 Edgar Street, Glen Iris	115.85	''	15/02/00
Mr D S L Tan, 48 Thompson Circuit, Mill Park	126.73	''	21/06/99
Mr D W & Mrs M Larsson, 16 Knutsford Street Balwyn	133.36	''	27/07/99
Mr Daniel & Mrs Susan Johnston, 123 Henry Street, Greensborough	265.45	''	23/12/99
Mr E & Mrs L Yuksel, Unit 1, 30 Tram Road, Doncaster	179.15	''	23/07/99
Mr E Crescia, 5 Upper Court, Nunawading	151.60	''	29/09/99
Mr E K & Mrs B G D'souza, 35 Monash Street, Box Hill	106.10	''	23/02/00
Mr Edward & Mrs Amy Amadi, 37 Oldwarrandyte Road, Donvale	335.80	''	15/09/99
Mr F & Mrs P Christopoulos, 13 Crawley Street, Reservoir	101.50	''	26/11/99
Mr F & Mrs V Persico, 53 Sunrise Drive, Greensborough	157.74	''	01/04/99
Mr F Branca, 28 Mitchell Street, Northcote	222.13	''	05/05/99
Mr F E J Galbally, 24 Streeton Crescent, Ivanhoe	290.73	''	27/07/99
Mr F L Napoli & Ms S Mandoulidis, Unit 2, 15 Sainsbury Avenue, Greensborough	123.79	''	20/08/99
Mr F Tomasi, 104 Melbourne Hill Road, Warrandyte	136.90	''	13/08/99
Mr F Walters, C/O State Trustees Ltd, 168 Exhibition Street, Melbourne	655.30	''	10/02/00

Mr Frank Apostolopoulos, 14 Miram Court, Westmeadows	111.45	''	06/08/99
Mr Frank Timmons, 6 Kelvinside Street, Balwyn North	351.20	''	10/09/99
Mr G & Mrs T Velardi, 46 Hutton Street, Thornbury	127.90	''	15/06/99
Mr G C & Mrs S M Clingin, 35A Pines Way, Craigieburn	118.97	''	21/09/99
Mr G Chirside, 259 Hotham Street, Elsternwick	133.70	''	21/02/00
Mr G T Prouse, Republic Tower, Apartment 153-154, 299 Queen Street, Melbourne	117.95	''	02/08/99
Mr G Tanti, 46 Patterson Street, Coburg	150.75	''	27/08/99
Mr G W & Mrs M G Auty, 140 Yea Road, Whittlesea	215.50	''	17/03/99
Mr H J & Mrs J E Kleinsman, Deal Corp P/L, Suite 44, 321 Toorak Avenue, Toorak	139.98	''	28/06/99
Mr H Karamon, 32 Emma Street, Fawkner	130.00	''	08/06/99
Mr H L & Mrs J V Wallace, 10 Auburn Grove, Armadale	164.87	''	13/09/99
Mr Ho L Man, Unit 13, 724 Station Street, Box Hill	107.70	''	12/07/99
Mr I G & Mrs M G Browning, Palmerston Street Baddaginie	116.90	''	08/06/99
Mr I Goodfellow, 15 Warida Avenue, Malvern East	141.30	''	07/02/00
Mr I R & Mrs S J Mannix, 10 Tudor Court, Ringwood East	156.15	''	25/03/99
Mr Ian Loxton, PO Box 1219, East Doncaster	143.95	''	22/11/99
Mr J & Mrs E Douglas, 175 George Street, Doncaster	204.33	''	08/02/00
Mr J & Mrs R Walker, 33 Loongana Avenue, Glenroy	176.44	''	24/12/99
Mr J & Mrs V Koro, 6 Cascade Street, Balwyn North	120.40	''	13/10/99
Mr J Caulifield, Unit 1, 30 Elizabeth Street, Bulleen	115.35	''	03/11/99
Mr J Golino, 12 Berry Street, Clifton Hill	192.90	''	12/11/99
Mr J H & Mrs B D Mellish, 3 Platypus Place, Morang South	106.44	''	01/12/99
Mr J H & Mrs J A Apperley, C/O Maddock Lonie & Chisolm Level 7, 140 William Street, Melbourne	316.85	''	09/12/99
Mr J Kickebosch, 69 Kubis Drive, Ringwood North	290.49	''	19/01/00
Mr J Kulandai & Ms K F Chong, 3 Dick Street, Ivanhoe	197.63	''	27/08/99
Mr J S & Mrs A McDonald, 403 Browns Road, Rye	105.20	''	12/08/99
Mr J S Thompson, Flat 6, 141 Marshall Street, Ivanhoe	140.10	''	07/10/99
Mr J Spinks, 26 Jordan Street, Malvern	106.65	''	01/09/99
Mr John Assimakopoulos, 2aA Affleck Street, South Yarra	213.95	''	13/08/99
Mr K & Mrs E Jordan, 2 Pareira Court, Mill Park	110.10	''	16/11/99
Mr K & Mrs M Gill, 5 Cherry Tree Lane, Box Hill	138.15	''	22/08/99
Mr K & Mrs R Nikolovski, 117 Hansworth Street, Mulgrave	151.85	''	03/05/99
Mr K E & Mrs J L Watkins, 3 Willoby Avenue, Glen Iris	116.26	''	28/07/99
Mr K M Lau, 1-3 Cobden Street, North Melbourne	104.55	''	01/11/99
Mr K W & Ms M T Bolt, 61 Horace Street, Malvern	238.09	''	07/07/99
Mr L F So, 52 Lester Avenue, St Albans	183.14	''	26/05/99
Mr L G & Mrs C J Mason, 34 Ridge Road, Fiarhaven	201.50	''	18/02/00
Mr L M & Mrs D Pura, PO Box 1164, Caulfield North	200.00	''	21/07/99
Mr M & Mrs A Deka, 35 Hartnett Street, Boronia	153.75	''	14/05/99
Mr M & Mrs A Simunic, Unit 4, 10 Day Street, Dandenong	650.43	''	29/07/99
Mr M & Mrs B Moujalleo, 33 Sylvester Grove, Preston	120.32	''	20/12/99
Mr M & Mrs L E Mercuri, Unit 8, 40 Pitt St, Sydney, NSW	118.45	''	16/11/99
Mr M & Mrs N Aydin, 21 King Street, Broadmeadows	109.45	''	06/07/99
Mr M A Rollo & Ms T K Purvis, 12 Parklink Place, Ringwood	183.00	''	27/10/99
Mr M Briscoe & Ms R D Camilleri, 98 Frangipani Drive, Yeppoon, Qld	134.45	''	20/12/99
Mr M Contes, 6 Forest Place, Templestowe	200.51	''	26/10/99
Mr M D J Frigo, 20 Gordon Court, Mooroolbark	240.00	''	29/10/99
Mr M G & Mrs K A Andrulis, Level 1, 1 Princess St, Kew	166.30	''	12/07/99

Mr M G Pettitt, 16 Pierre Street, Woori Yallock	192.00	''	28/07/99
Mr M Higgins & Ms B Dunn, 78 Kambrook Road, Caulfield North	185.50	''	26/11/99
Mr M I Fannin & Ms L C Gianella, Unit 2, 207 Greenvale Drive, Greenvale	106.15	''	30/08/99
Mr M J & Mrs M J Wilkins, 10 Power Avenue, Toorak	121.73	''	05/08/99
Mr M J & Mrs S M Caithness, 1 Coral Court, Plenty Lower	146.61	''	16/03/99
Mr M J Chapman & Ms L M Cooke, 27 Marcus Street, Mount Evelyn	102.95	''	31/05/99
Mr M Love, 37 Heads Road, Donvale	104.26	''	29/10/99
Mr M M Hiort, 28 Warra Street, Toorak	119.30	''	14/02/00
Mr M R & Mrs A M Bender, PO Box 52, Glen Iris	101.85	''	01/09/99
Mr M Redfern, 7 Huntley Street, Watsonia	134.30	''	25/11/99
Mr M Turner, PO Box 116, Kalorama	300.55	''	20/10/99
Mr Mark Snider, 84 Clarke Drive, Tullamarine	109.75	''	18/10/99
Mr Mark Walters & Ms S Elliott, 72 Medway Street, Box Hill North	193.65	''	22/11/99
Mr N & J & Mesdames M & Mtsapsalis, 982 Doncaster Road, Doncaster East	141.23	''	22/07/99
Mr N A & Mrs H M Vickery, 34 Stanhope Grove, Camberwell	119.20	''	29/10/99
Mr N A & Mrs S E Copp, 24 View Street, Croydon	126.30	''	08/12/99
Mr N Togni & Ms K Mason, 33 Hillcrest Road, Eltham	183.74	''	19/04/99
Mr N Zachariadis, 2 Appleblossom Court, Templestowe	106.35	''	15/09/99
Mr P B & Mrs M E Connell, PO Box 234, South Yarra	603.50	''	28/07/99
Mr P C J & Mrs D F Volkering, PO Box 1155, Glen Waverley	124.30	''	31/10/99
Mr P F Ong, C/O Stockdale & Leggo, 18 James Street Templestowe	222.40	''	25/08/99
Mr P G & Mrs A J Archibald, 6 O'Neil Way, Ringwood North	200.61	''	15/12/99
Mr P G & Mrs V K Richter, C/O D G Jones & Partners, Suite 8, 663 Victoriay Street, Abbotsford	295.95	''	22/06/99
Mr P G Cawthorn & Ms C A Pollard, 32 Finch Street, East Malvern	145.06	''	16/02/00
Mr P G Obbink & Ms J A Kitch, 88 Eve Road, Bellview Heights, SA	125.65	''	09/06/99
Mr P J & Mrs K L Belford, C/O Mr P J Belford, PO Box 13, Preston	310.00	''	26/10/99
Mr P J & Mrs K M Castles, 18 Hamilton Street, Brunswick West	149.80	''	04/12/99
Mr P J Clark, Shop 2, 35 Drysdale Road, Warrandyte	183.30	''	18/01/00
Mr P L & Mrs S R Robinson, 14 Turner St, Malvern East	112.48	''	24/06/99
Mr P R & Mrs K A Stenteford, 123 Kangaroo Ground, Warrendyte Road, Warrandyte North	150.95	''	15/09/99
Mr P Robinson, 44 Grimes Road, Point Lonsdale	108.28	''	13/07/99
Mr P S Daicos, 16 Luena Road, Balwyn North	359.75	''	02/09/99
Mr P V & Mrs M A Desmond, 24 Jackson Street, Northcote	382.68	''	23/02/00
Mr Peter Armstrong, 68 Spring Street, Port Melbourne	229.70	''	06/09/99
Mr Peter J & Mrs D J Dyson, 1 Hilda Crescent, Hawthorn	120.49	''	19/07/99
Mr R & Mrs M Caruso, 65 Massey Avenue, Reservoir	260.36	''	16/12/99
Mr R Curtin Sinclair, C/- 191 Balaclava Road, Caulfield Nth	161.15	''	18/08/99
Mr R F & Mrs J F Hunter, 1209 Mount Dandenong Tourist Road, Kalorama	120.00	''	13/05/99

Mr R G Morris, 87 Gladstone Street, Kew	106.80	''	16/07/99
Mr R Gardiner, Unit 2, 504 Moreland Road, Brunswick West	100.75	''	26/02/00
Mr R H & Mrs L V French, 8 Summit Drive, Eaglemont	101.94	''	13/12/99
Mr R L & Mrs S Burubu, 9 Marshall Avenue, Kew	127.62	''	25/01/00
Mr R R & Mrs L Premier, 168 Dorking Road, Box Hill North	212.40	''	30/11/99
Mr R T & Mrs G J Glogoski, Unit 1, 665 Whitehorse Road, Mitcham	144.94	''	21/07/99
Mr R W Boone, 83 Camelot Drive, Glen Waverley	144.16	''	10/08/99
Mr Robert Strangers, 13 Inverness Street, Reservoir	153.45	''	02/08/99
Mr S A Bolton, C/- Mahons, 178 Whitehorse Road, Balwyn	123.10	''	10/08/99
Mr S B & Mrs V Chrusciel, 6A Pelham Court, Epping	113.45	''	11/10/99
Mr S H & Ms K L Anderson, 28 Boyce Avenue, Briar Hill	100.20	''	15/07/99
Mr S Hopman, 31 Springvale Road, Nunawading	125.75	''	04/11/99
Mr S J & Mrs L M Thomson, 43 Myers Avenue, Glen Waverley	191.65	''	17/10/99
Mr S J Lee, 62 Wattle Valley Road, Canterbury	106.92	''	01/09/99
Mr S L Foulds, 8 Miranda Court, Noble Park	110.50	''	12/07/99
Mr S Livadaras & A T Assauw, Unit 2, 12 Bowen Street, Malvern East	215.63	''	10/12/99
Mr S W & Mrs J L Wynd, PO Box 2082, Greenvale	185.80	''	18/11/99
Mr S W Hine, 15 Mountain View Road, Kilsyth	101.15	''	21/06/99
Mr T De Agostino, 86 Hedderwick Street, Essendon	101.25	''	19/05/99
Mr T Edwards, Unit 10, 70 The Boulevard, Malvern East	111.05	''	29/10/99
Mr T J Frohlich, Unit 9, 138-140 Chuter Avenue, Sans Souci, NSW	169.00	''	20/07/99
Mr T Neville & Ms M Lochmund, 15 Pallant Avenue, Reservoir	201.55	''	25/08/99
Mr T R & Mrs M Winters, 43 Sackville Street, Kew	147.50	''	11/02/00
Mr Trevor Haig, 100 Glass Street, Essendon	145.00	''	19/10/99
Mr V W & Mrs M V Setches, Unit 2, 69a Palmerston Street, Carlton	101.99	''	23/07/99
Mr W & Mrs A Dinakis, C/- Collards, 312 Station Street, Lalor	123.50	''	01/11/99
Mr X Q Yang, Unit 2, 1 Clarke Place, Mount Waverley	119.55	''	30/07/99
Mrs A & Mr P Sundberg, 8 Grant Street, Malvern East	135.35	''	13/12/99
Mrs C J Place & Mr B L Knights, 3 Edmonds Avenue, Ashburton	106.83	''	05/08/99
Mrs D A & Mr P J Knight, 1 Thomson Grove, Mildura	132.10	''	02/06/99
Mrs D E O'Toole, 50 The Boulevard, Balwyn North	156.25	''	18/08/99
Mrs I M Frie, Unit 1, 13 Hartington Street, Elsternwick	102.65	''	14/05/99
Mrs K A & Mr J Dyason, 27 Elms Road, Mooroolbark	124.15	''	18/01/00
Mrs L Butler, 4 Carnarvon Court Sunbury	198.00	''	12/07/99
Mrs L F Lee, PO Box 39, Violet Town	150.83	''	13/09/99
Mrs L F Lee, PO Box 39, Violet Town	118.87	''	31/08/99
Mrs L M Dossetor, 18 Bradford Avenue, Surrey Hills	150.40	''	23/02/00
Mrs Paula Grey, 11 Marne Road, Mount Evelyn	250.00	''	05/10/99
Mrs R M Jokubaitis, 60 Rathmullen Quadrant, Doncaster	153.95	''	17/02/00
Mrs R Polzella, 434 Brunswick Road, Brunswick West	112.03	''	17/12/99
Mrs S & Mr S K Rogers, Unit 6, 216 Templestowe Road, Templestowe Lower	135.84	''	12/03/99
Mrs S Ercan, Unit 5, 7 Lawford Street, Doncaster	194.25	''	26/08/99
Ms A Ferguson, 42 Dean Street, Kew	131.30	''	11/08/99
Ms A J Clifford, 29 Lakeview Crescent, St Leonards	156.85	''	17/08/99

Ms A Michod, Unit 2, 23–25 Marne Street, South Yarra	152.59	”	02/12/99
Ms B Hillard, 18 Hume Street, Greensborough	140.94	”	30/06/99
Ms C J Le Couteur, PO Box 547, Templestowe	292.61	”	20/10/99
Ms C Kellie-Main, 14 Bareena Grove, Doncaster East	111.12	”	27/09/99
Ms C O’Brien, PO Box 4345, Ringwood	324.00	”	01/11/99
Ms D Broderick, C/O Kahns, Level 9, 501 Latrobe Street, Melbourne	130.20	”	12/07/99
Ms D Parker, 22 Crawley Grove, Ringwood North	127.00	”	20/11/99
Ms E D Desteere, 7 Gardiner Avenue, Anglesea	148.15	”	04/01/00
Ms J Coram, 43 Hopetoun Grove, Ivanhoe	296.70	”	26/10/99
Ms J D Castle, 14 Alma Street, Plenty Lower	120.60	”	30/11/99
Ms J E Cheatley, 21 Reid Street, Balwyn	257.35	”	30/06/99
Ms J E Porter, 30 Merton Street, Box Hill	200.78	”	24/12/99
Ms Jacinta Minehan, 198 Raglan Street, Preston	208.95	”	24/08/99
Ms K A McKendrick, 14 Huntingdon St, Newtown, Geelong	401.90	”	15/02/00
Ms K Hughs, 56 Phipps Crescent Diamond Creek	139.29	”	29/10/99
Ms Kellie J Connolly, 108 Princes Street, Traralgon	108.50	”	28/09/99
Ms Kirstie Melissa Wallace, 7 Hope Street, Spotswood	115.20	”	04/10/99
Ms M A Frasz, C/O Maarten A Frasz, 34 View Street, Alphington	148.65	”	19/10/99
Ms M Henley-Collopy, Unit 1, 60 Avendon Boulevard, Glen Waverley	158.34	”	29/09/99
Ms M J Mccallum, 27 Young Street, Kew	164.43	”	30/07/99
Ms M Ryan, 87 Delta Road, Greensborough	136.95	”	10/09/99
Ms M S Berman, 11 Grant Avenue, Toorak	121.77	”	04/02/00
Ms N Muir, 33 Lawrence Drive, Berwick	139.75	”	25/02/00
Ms P J Bear, 10 Ahswood Drive, Seaford	236.35	”	27/04/99
Ms P J Murphy, 6 Coolgardie Avenue, Malvern East	103.85	”	19/11/99
Ms R Cabble, Unit 3, 765 Burwood Road, Hawthorn East	116.70	”	31/08/99
Ms S Arabi, 4 Fiesta Court, Thomastown	111.45	”	13/01/00
Ms S M Woolard, 10 Lemon Grove Crescent, Croydon Hills	116.65	”	20/05/99
Ms T Casha & Mr R Casha, 445 Epping Road, Wollert	139.05	”	25/10/99
Ms T L Lucas, 14 St Georges Road, Toorak	132.84	”	21/10/99
Ms T Powell, 21 Salisbury Avenue, Warburton	219.55	”	20/10/99
Ms Tamie Pederson, PO Box 131, Wandin North	105.95	”	24/08/99
Ms W Versace, 48 Eastgate Street, Pascoe Vale	156.70	”	28/07/99
Ms Y J Kearley, 29–30 Mack Road, Narre Warren	117.69	”	18.08/99
N D H Investments Pty Ltd, PO Box 756, Frankston	395.30	”	26/10/99
N M Computer Services Pty Ltd, Level 18, 447 Collins Street, Melbourne	1,401.98	”	23/07/99
Naji Investments Pty Ltd, 1 Nellie Street, Camp Hill, Qld	104.30	”	19/10/99
Narsin Nominees, PO Box 1164, Caulfield North	826.48	”	17/08/99
National Australia Bank, PO Box 1988, Canberra, ACT	351.79	”	26/01/00
Od Pty Ltd, 18 James Street, Fawkner	224.53	”	02/09/99
P & G Arcadia Builders Pty Ltd, 8 Juniper Crescent, Thomastown	101.32	”	17/01/00
Palm Gully Pty Ltd, Floor 1, 17 Carrington Road, Box Hill	444.17	”	03/11/99
Paltell Pty Ltd, 116 Tyler Street, Preston	191.41	”	17/02/00
Pinewood Homes Pty Ltd, 24 Epping Road, Epping	198.47	”	06/01/00
Polda Pty Ltd, Rear of 609 Bridge Road, Richmond	679.95	”	15/11/99
Portlock Pty Ltd & Mr G A Kennedy, 43 Barry Road, Campbellfield	176.80	”	20/08/99
Pro Built Homes Pty Ltd, 14 The Loop, Glenroy	130.00	”	16/09/99

Public Transport Corp, Ghetto Sport And Street, Level 2, 257 Toorak Road, South Yarra	181.30	''	18/08/99
R I R Holdings Pty Ltd, C/O Drake Real Estate, 483 Whitehorse Road, Mitcham	172.60	''	02/09/99
Railway Hotel, 18 Willow Grove, East Kew	197.63	''	24/01/00
Reghon Pty Ltd, Floor 1, 333 Drummond Street, Carlton South	351.94	''	26/08/99
Reghon Pty Ltd, Floor 1, 333 Drummond Street, Carlton South	128.00	''	18/01/00
Robert Jones & Leanne Evans, Rsm 1021, Cobram	160.10	''	12/08/99
Saranick Pty Ltd, Burgundy Hill Consulting, 445 Upper Heidelberg Road, Heidelberg Heights	340.65	''	11/02/00
Sidoti Constructions Pty Ltd, 11 Edward Street, Macleod	114.05	''	31/05/99
Silver Unicorn Pty Ltd, 19 Maud Street, Ormond	356.45	''	18/11/99
Songaid Pty Ltd, 30 Glenferrie Road, Malvern	115.17	''	31/07/99
Specialised Construction & Management Pt, PO Box 1311, Kensington	149.00	''	15/02/00
Statewide Building Society, C/O Westpac Property Services, GPO Box 4180 Sydney, NSW	531.50	''	12/10/99
Supported Housing Development Foundation, Suite 1, 420 High Street, Kew	161.80	''	21/02/00
Talawood Pty Ltd, PO Box 1136, Upwey	166.02	''	16/11/99
Telstra Property Operations, C/O Transfield Maintenance, PO Box 12368, Melbourne	236.41	''	02/07/99
The Baptist Union of Victoria, C/O Allard & Shelton Pty Ltd, 267 Collins Street, Melbourne	372.36	''	15/07/99
The Mall Fish & Chip, Shop 4, The Mall, Heidelberg West	300.00	''	15/06/99
The Shell Company of Australia, Level 5, 991 Whitehorse Road, Box Hill	350.85	''	07/10/99
The Shell Company of Australia, Level 5, 991 Whitehorse Road, Box Hill	348.73	''	''
The Shell Company of Australia, Level 5, 991 Whitehorse Road, Box Hill	347.90	''	''
The Shell Company of Australia, Level 5, 991 Whitehorse Road, Box Hill	279.61	''	''
The Shell Company of Australia, Level 5, 991 Whitehorse Road, Box Hill	278.64	''	''
The Shell Company of Australia, Level 5, 991 Whitehorse Road, Box Hill	272.44	''	''
The Shell Company of Australia, Level 5, 991 Whitehorse Road, Box Hill	266.93	''	''
The Shell Company of Australia, Level 5, 991 Whitehorse Road, Box Hill	219.80	''	''
The Shell Company of Australia, Level 5, 991 Whitehorse Road, Box Hill	218.16	''	''
The Shell Company of Australia, Level 5, 991 Whitehorse Road, Box Hill	192.12	''	''
Vic Port Pty Ltd & Simply Tops Pty Ltd, PO Box 4070 Richmond	269.80	''	06/07/99
Vic Tas Fuels, Victorian Retail Operations, Mobile Oil Aust, GPO Box 4507, Melbourne	150.00	''	12/07/99
War Widows Guild, 120 Princess Street, Kew	154.00	''	31/05/99

Victoria Government Gazette

G 17 26 April 2001

743

Wendale Pty Ltd, C/O Granitek Pty Ltd,
22 Lionel Road, Mount Waverley

131.95

”

19/06/99

01040

CONTACT: JANE CUMMING, PHONE: (03) 9872 1210

PROCLAMATIONS

Gambling Legislation

(Miscellaneous Amendments) Act 2000

PROCLAMATION OF COMMENCEMENT

I, John Landy, Governor of Victoria, with the advice of the Executive Council and under section 2(2) of the **Gambling Legislation (Miscellaneous Amendments) Act 2000**, fix 26 April 2001 as the day on which sections 5, 9, 10(3), 11, 12, 22(2), 37, 41, 42 and 53 of that Act come into operation.

Given under my hand and the seal of Victoria on 24 April 2001.

(L.S.) JOHN LANDY
Governor

By His Excellency's Command

JOHN PANDAZOPOULOS
Minister for Gaming

Gaming No. 2

(Community Benefit) Act 2000

PROCLAMATION OF COMMENCEMENT

I, John Landy, Governor of Victoria, with the advice of the Executive Council and under section 2(1) of the **Gaming No. 2 (Community Benefit) Act 2000**, fix 26 April 2001 as the day on which the remaining provisions of Part 5 and Part 6 of that Act come into operation.

Given under my hand and the seal of Victoria on 24 April 2001.

(L.S.) JOHN LANDY
Governor

By His Excellency's Command

JOHN PANDAZOPOULOS
Minister for Gaming

**GOVERNMENT AND OUTER BUDGET SECTOR AGENCIES
NOTICES**

HUME CITY COUNCIL
Road Discontinuance

At its meeting on 23 April 2001 and acting under clause 3 of Schedule 10 to the **Local Government Act 1989** Hume City Council resolved to discontinue the road known as Albert Close, Craigieburn being part of the road identified as R1 on PS439636E and part of the land in certificate of title volume 10535, folio 874 shown hatched on the plan below.

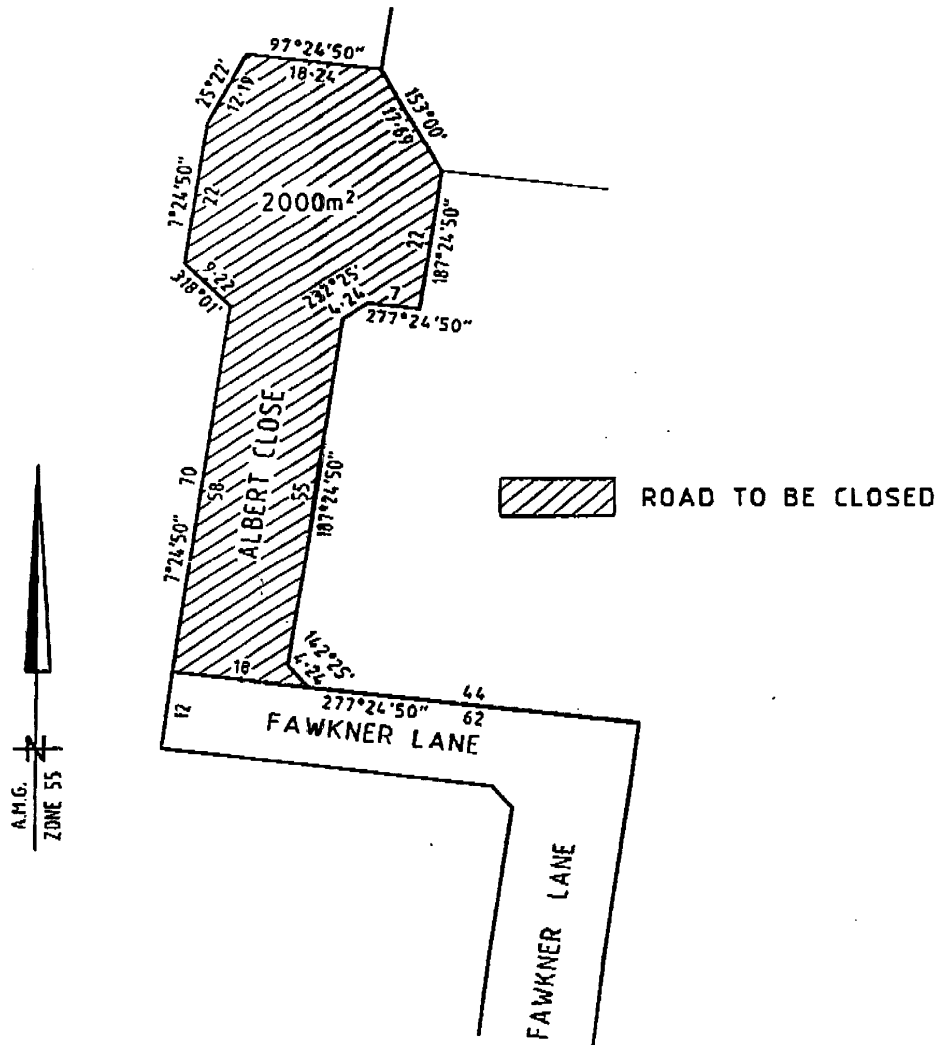

Mr DARRELL TRELOAR
Chief Executive Officer

DAREBIN CITY COUNCIL

Erratum

Discontinuance of Road – City of Darebin

Victoria Government Gazette G13

29 March 2001 – Page 528

Notice is hereby given that the notice published on page 528 of the Victoria Government Gazette G13 dated 29 March 2001 was incorrect. The notice below replaces that previously published.

DAREBIN CITY COUNCIL

Road Discontinuance

Pursuant to section 206 and Schedule 10, clause 3 of the **Local Government Act 1989**, the Darebin City Council, at its ordinary meeting held on 5 March 2001, formed the opinion that the road at the rear of 759 and 787 and adjacent to 797 Plenty Road, rear 1 to 7 Rubicon Street, rear 18 to 38 Home Street and adjacent to 2 Wilkinson Street, Reservoir and shown hatched on the plan below, is not reasonably required as a road for public use and resolved to discontinue the road and to sell the land from the road by private treaty to the abutting property owners.

The road is to be sold subject to the right, power or interest held by the following authorities in the road in connection with any sewers, drains or pipes under the control of those authorities in or near the road:

- Section designated E-1 on the plan – Yarra Valley Water Limited.
- Section designated E-2 on the plan – Vic Gas Distribution Pty Ltd.
- Section designated E-3 on the plan – Yarra Valley Water Limited and Vic Gas Distribution Pty Ltd.

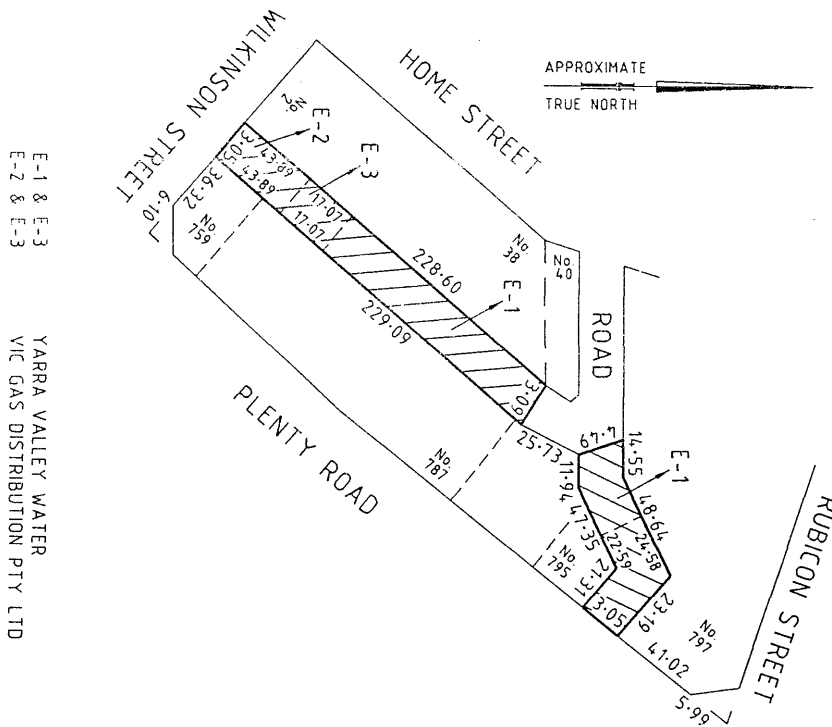

PHILLIP SHANAHAN
Chief Executive Officer

KINGSTON CITY COUNCIL
Road Discontinuance

Pursuant to section 206 and schedule 10, clause 3 of the **Local Government Act 1989**, the Kingston City Council at its meeting held on 26 March 2001 formed the opinion that the road at the rear of Unit 7, 438 Nepean Highway and 259 Como Parade East, Parkdale, and shown by hatching on the plan below, is not reasonably required as a road for public use and resolved to discontinue the road and to sell the land from the road by Private Treaty to abutting property owners.

The road is to be sold subject to the right, power or interest held by the Kingston City Council and South East Water Limited, in the road in connection with any sewers, drains or pipes under the control of those authorities in or near the road.

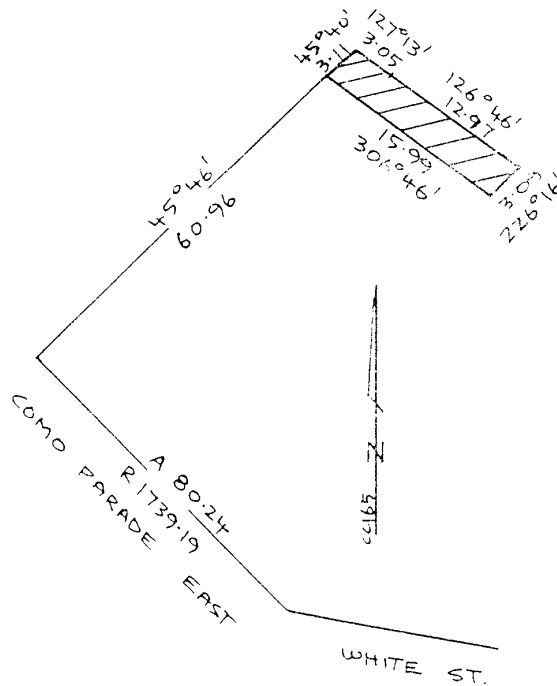

ROB SKINNER
Chief Executive Officer



Discontinuance of Road –
Part of Sail Street, Shoreham

Pursuant to Section 206 and Schedule 10, Clause 3 of the **Local Government Act 1989**, the Mornington Peninsula Shire Council has formed the opinion that part of Sail Street, Shoreham, as shown hatched on the plan below, is not reasonably required as a road for public use. Council has resolved to discontinue this portion of road and to sell it to the adjoining owners.

The section of road shown as E-1 is subject to any right, power or interest held by the Mornington Peninsula Shire Council in connection with any drains or pipes under the control of this

authority in or near the road. The section of road shown as E-2 is subject to any right, power or interest held by United Energy and Telstra Corporation in connection with any wires, cables or plant under the control of these authorities in or near the road.

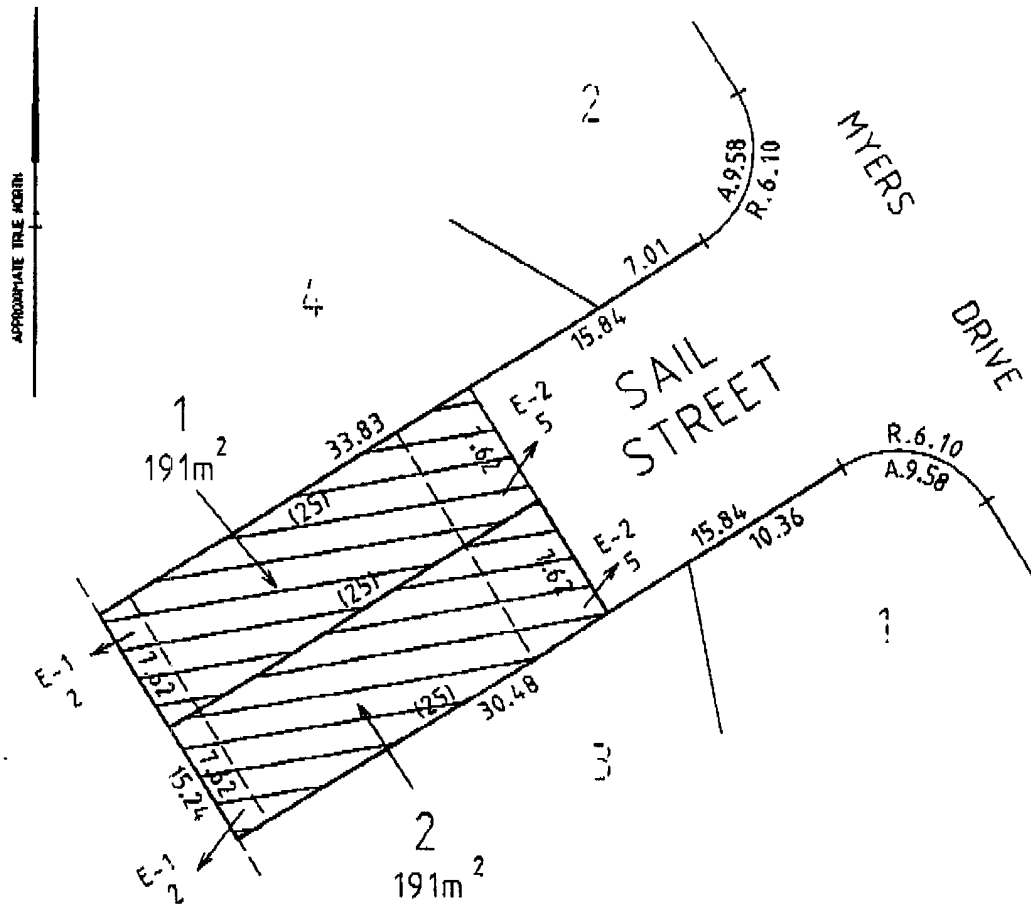

MICHAEL KENNEDY
Chief Executive Officer



Discontinuance of Road –
Part Charles Street, Mornington

Pursuant to Section 206 and Schedule 10, Clause 3 of the **Local Government Act 1989**, the Mornington Peninsula Shire Council has formed the opinion that part of Charles Street, Mornington, as shown hatched on the plan below, is not reasonably required as a road for public use. Council has resolved to discontinue this portion of road and to sell it to the adjoining owner. The section of road shown as E-1 is subject to any right, power or interest held by the Mornington

Peninsula Shire Council and South East Water Limited in connection with any sewers, drains, pipes, wires or cables under the control of this authority in or near the road.

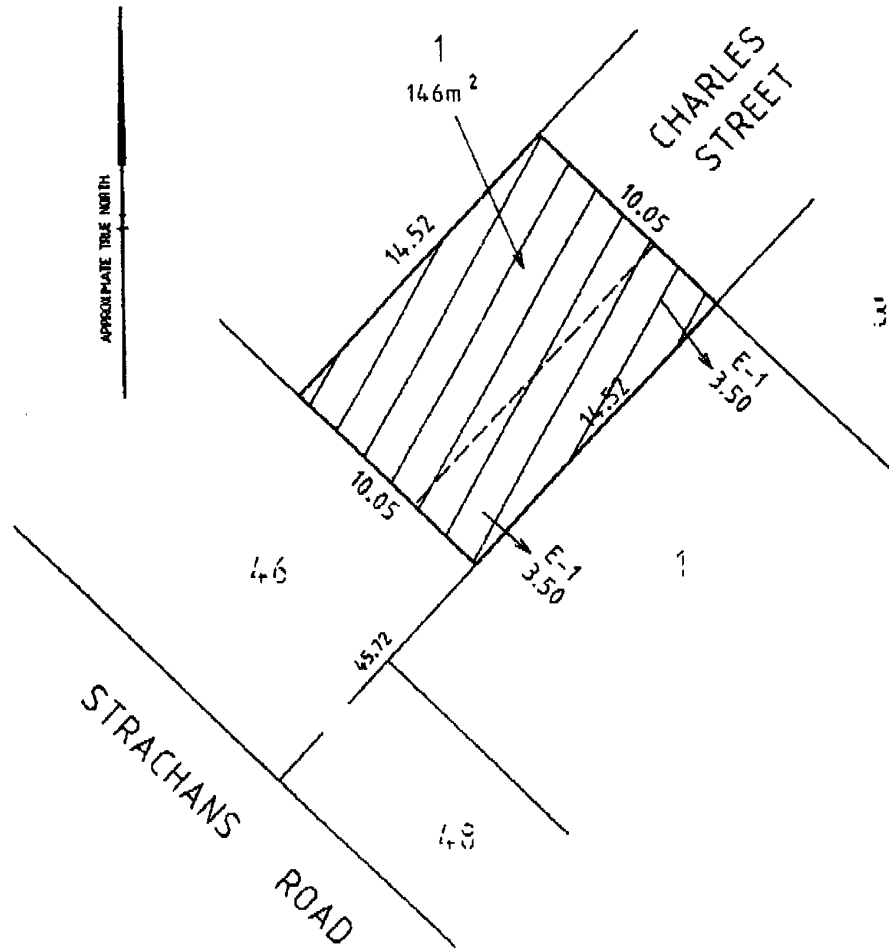

MICHAEL KENNEDY
Chief Executive Officer



Discontinuance of Road –
Part Nepean Place, Portsea

Pursuant to Section 206 and Schedule 10, Clause 3 of the **Local Government Act 1989**, the Mornington Peninsula Shire Council has formed the opinion that part of Nepean Place, Portsea, as shown hatched on the plan below, is not reasonably required as a road for public use. Council has resolved to discontinue the portion of road and to sell the land from the road by private treaty to the adjoining owner.

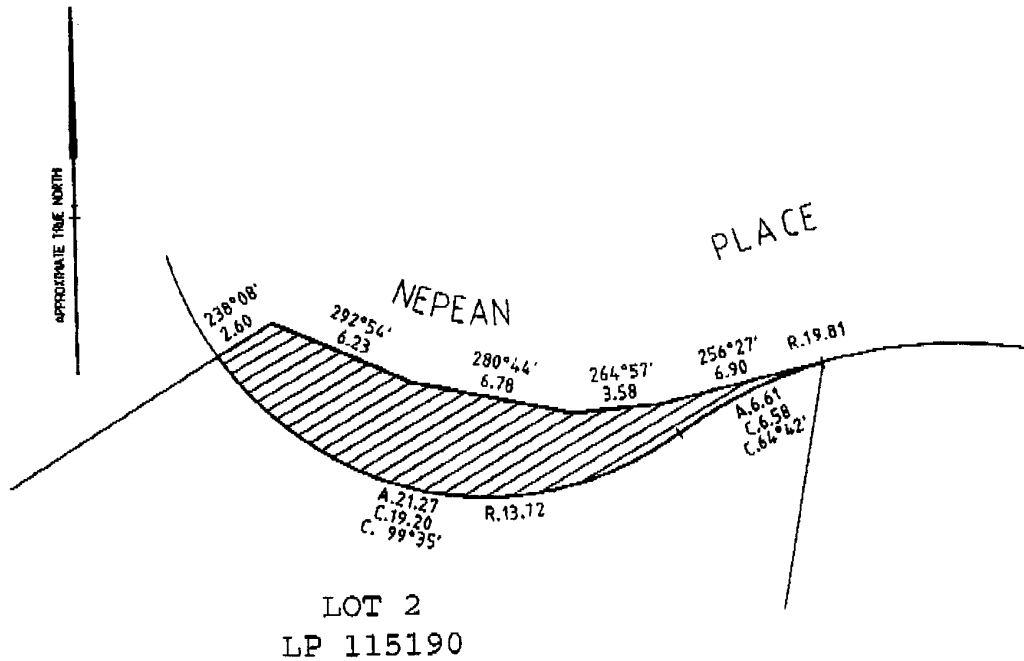

MICHAEL KENNEDY
Chief Executive Officer

MOIRA SHIRE COUNCIL
Notice of Proposed Local Law

Moira Shire Council proposes to make Meeting Procedures Local Law 2001 (No. 1 of 2001) to provide for the orderly conduct of Council meetings. The Local Law is an update of the existing Administration and Meetings Local Law 1995 (No. 1 of 1995).

The purpose (objectives) of the proposed local law is to:

- (a) regulate and control the procedures governing the conduct of meetings of the Council and of special committees appointed by the Council; and
- (b) regulate and control the election of the Mayor and the Chairpersons of any special committees; and
- (c) regulate and control the use of Council's seal; and
- (d) promote and encourage community participation in the local government system; and
- (e) provide a mechanism through its formal meeting procedure to ensure effective and efficient Council decisions are made in a manner which acknowledges the role of local government within the Australian system of Government; and
- (f) provide for the administration of the Council's powers and functions; and
- (g) provide generally for the peace, order and good government of the municipal district.

This Local Law also provides for the repeal of Local Law No.1 of 1995 and fixes penalties for the breach of certain provisions.

Copies of the proposed local law may be inspected at or obtained from the Service Centres at Melville Street, Numurkah; Station Street, Cobram and Belmore Street, Yarrawonga.

Any person affected by the proposed Local Law or any part of the proposed Local Law may make a submission to the Council in accordance with Section 223 of the **Local Government Act**

1989. Any person requesting to be heard in support of a written submission is entitled to appear before a meeting of Council either personally or by a representative acting on that person's behalf and will be notified of the time and date of that hearing.

Submissions may be lodged at the Council's Service Centre listed above or posted to the Moira Shire Council, PO Box 132, Numurkah 3636, so as to reach the Council no later than Friday 8 June 2001.

Any enquiries may be directed to the Chief Executive Officer on telephone (03) 5862 0222.

GAVIN CATOR
Chief Executive Officer

SURF COAST SHIRE COUNCIL
Local Law No. 20 of 2001

Environmental (Amendment No. 5)

Notice is hereby given that the Council of the Surf Coast Shire, under the provisions of the **Local Government Act 1989**, proposes to make Local Law No. 20 of 2001 amending Local Law No. 5 of 1995 – Environmental.

The purpose of the Local Law is to amend the Environmental Local Law No. 5 of 1995 to require a person to obtain a permit to place bulk waste containers on any land, road or public place and to amend Schedule 8 of the Principal Local Law and incorporate VicRoads' Code of Practice for the Placement of Waste Bins on Roadsides into the Schedule.

A copy of the Local Law may be obtained from the Surf Coast Shire Offices, 25 Grossmans Road, Torquay.

Any person affected by the proposed Local Law may make a written submission to the Council. Submissions received within 14 days of the publication of this notice will be considered by Council in accordance with Section 223 of the **Local Government Act 1989**.

A person requesting that she or he be heard in support of the written submission is entitled to appear before a meeting of the Council either personally or by a person acting on her or his behalf and will be notified of the time and date of the hearing.

DIANA PATTERSON
Chief Executive Officer



Public Holidays Act 1993

The Moorabool Shire Council under Section 7 of the **Public Holidays Act 1993**, appoints Tuesday 6 November 2001 (Melbourne Cup Day) 2001 as a Public Holiday throughout the entire Moorabool Shire.

CHRIS GILLARD
Chief Executive Officer

WELLINGTON SHIRE COUNCIL
Public Holidays Act 1993

Notice is hereby given that the Wellington Shire Council pursuant to Section 7(1)(b) of the **Public Holidays Act 1993** declares Wednesday 6 February 2002 as a public half-day holiday. This public half-day holiday from 12 noon is for the part of the municipal district of the former City of Sale. The purpose of this holiday is in recognition of the 2002 Sale Cup race meeting.

LEIGH HARRISON
Acting Chief Executive Officer

RURAL CITY OF WANGARATTA
Full Day Public Holiday
Tuesday, 6 November 2001

Notice is given that the Council of the Rural City of Wangaratta at its meeting held on 17 April 2001 has resolved to appoint Melbourne Cup Day, Tuesday 6 November 2001 as a full day public holiday throughout the municipality in accordance with Section 7 (1)(b) of the **Public Holidays Act 1993**.

GRAEME EMONSON
Chief Executive Officer

Planning and Environment Act 1987
ALPINE RESORTS PLANNING SCHEME
Notice of Amendment
Amendment C6

The Minister for Planning has prepared Amendment C6 to the Alpine Resorts Planning Scheme.

The Amendment revises the Local Planning Policy Framework and requirements that apply

to Mt Hotham Alpine Resort. It replaces the Mt Hotham Strategic Statement and introduces a Local Policy relating to Car Parking. The Amendment also introduces an Environmental Significance Overlay – Burrmys Parvus and a Heritage Overlay and four new incorporated documents in the form of Comprehensive Development Plans for Hotham Village, Davenport Road Frontage, Davenport Oversnow and the Interurban Break.

A copy of the Amendment can be inspected, free of charge, during office hours, at the Department of Infrastructure, Planning Information Centre, Upper Plaza, Nauru House, 80 Collins Street, Melbourne and the North East Regional Office, 50–52 Clarke Street, Benalla; the offices of the Alpine Shire, corner Hawthorn Lane and Churchill Avenue, Bright and the Mt Hotham Resort Management Board Office, Great Alpine Road, Mt Hotham.

Submissions about the Amendment must be sent to: Minister for Planning, Attention: Adrian Williams, Planning Panels Victoria, Department of Infrastructure, PO Box 2797Y, Melbourne 3001 by 28 May 2001.

PAUL JEROME
Executive Director
Planning, Heritage and
Building Division
Department of Infrastructure

Planning and Environment Act 1987

BANYULE PLANNING SCHEME

Notice of the Preparation of an Amendment
Amendment C20

Notice of an Application for Planning Permit
Application P100/01

The land affected by the Amendment and the application is 11A Vine Street, Heidelberg.

The Amendment proposes to rezone the land from Urban Floodway Zone to Residential 1 Zone.

The application is for a permit to construct a dwelling, garage and associated works and remove vegetation.

The person who requested the Amendment and the applicant for the permit is Superior Envirotech Marketing Pty Ltd (c/o Collie Planning and Development Pty Ltd).

You may inspect the Amendment and the application and draft conditions, and any documents that support the amendment and application, and the explanatory report about the amendment and application at the offices of Banyule City Council at: Rosanna Service Centre, 44 Turnham Avenue, Rosanna 3084; Ivanhoe Service Centre, 275 Upper Heidelberg Road, Ivanhoe 3079; Greensborough Service Centre, 9–13 Flintoff Street, Greensborough 3088 and Office of Planning & Heritage, Nauru House, Level 3 Plaza, 80 Collins Street, Melbourne 3000.

This can be done during office hours and is free of charge.

Any person who may be affected by the Amendment or by the granting of the permit may make a submission to the planning authority.

The closing date for submission is Monday 28 May 2001. A submission must be sent to Banyule City Council, Attention: Cindy Wilson, Development Planner, P.O. Box 51, Ivanhoe 3079.

SCOTT WALKER
City Planner



Planning and Environment Act 1987

CASEY PLANNING SCHEME

Notice of the Preparation of an Amendment
Amendment C23

The land affected by the Amendment is Allotment 21A, Town of Cranbourne, Parish of Cranbourne (Title Volume 4687 and Folio 937355), the former Cranbourne City Work Depot site located at O'Tooles Road, Cranbourne that is now disused and is surplus to Council requirements.

The Amendment proposes to rezone part of the land to Residential 1 Zone and part of the land (abutting the southern boundary) supporting wetland vegetation to Public Park and Recreation Zone.

Casey City Council has proposed and prepared the Amendment.

You may inspect the Amendment, any

documents that support the Amendment and the explanatory report about the Amendment at the office of the planning authority: Casey City Council, Municipal Offices, Princes Highway, Narre Warren; Casey City Council, Customer Service Centre, Sladen Street, Cranbourne and at the Department of Infrastructure, Customer Service Centre, Nauru House, 80 Collins Street, Melbourne.

You may also inspect the Amendment on the website of the City of Casey on www.casey.vic.gov.au.

This can be done during office hours and is free of charge.

Any person who may be affected by the Amendment may make a submission to the planning authority.

The closing date for submissions is 29 May 2001. A submission must be sent to: The Manager Planning, Casey City Council, Municipal Offices, PO Box 1000, Narre Warren 3805.

Should you have any queries about this matter, please contact Paulo Araujo on 9705 5591.

JACQUI HOUGUET
Manager Planning

Planning and Environment Act 1987
MARIBYRNONG PLANNING SCHEME
Notice of Amendment

Amendment C15

Maribyrnong City Council has prepared Amendment C15 to the Maribyrnong Planning Scheme.

Land affected by the Amendment:

Land affected by the Amendment is a portion of the land located on the northeast corner of Moore and Hopkins Street, Footscray, known as number 60 Hopkins Street.

The Amendment proposes to change the Maribyrnong Planning Scheme by: Applying a Public Acquisition Overlay to a small portion (38.2 square metres) of the above land. This is to facilitate the construction of a left turn lane for vehicles exiting Moore Street into Hopkins Street.

The City of Maribyrnong has prepared the Planning Scheme Amendment C15 at the request of VicRoads.

A copy of the Amendment can be inspected, free of charge, during office hours, at: Maribyrnong City Council, Reception Area, corner Hyde & Napier Streets, Footscray 3011 and Department of Infrastructure, Planning Information Centre, Upper Plaza, Nauru House, 80 Collins Street, Melbourne 3000.

Submissions about the Amendment

Written submissions about the Amendment must be sent to: The General Manager – Urban Environments, Maribyrnong City Council, PO Box 58, Footscray, Vic. 3011.

Submissions must be received by no later than 14 May 2001.

Planning and Environment Act 1987
MANNINGHAM PLANNING SCHEME
Notice of Amendment

Amendment C4

Notice of an Application for Planning Permit
Application PLA 12071

The land affected by the Amendment is Lot 1 PS 343492L Doncaster Road, Doncaster.

The land affected by the application is Lot 1 PS 343492L Doncaster Road, Doncaster.

The Amendment proposes to rezone Lot 1 PS 343492L Doncaster Road, Doncaster from a Residential 1 Zone to a Mixed Use Zone, incorporating in the schedule to the zone 80 square metres for Shop and zero square metres for Office and Trade supplies, for the land comprising Lot 1 PS 343492L.

The application is for a permit to use and develop the land for a Transport Terminal (Park and Ride facility).

The person who requested the Amendment and the applicant for the permit is VicRoads through Taylors Surveyors and Planners.

You may inspect the Amendment and the application; any documents that support the amendment and the application; and the explanatory report about the amendment and application at the office of the planning authority, Manningham City Council and at the Department of Infrastructure at the following addresses: City of Manningham, 699 Doncaster Road, Doncaster 3108 and Department of Infrastructure, Customer Service Centre, Level 3 Plaza, Nauru House, 80 Collins Street, Melbourne 3000.

This can be done during office hours and is free of charge.

Any person who may be affected by the Amendment or by the granting of the permit may make a submission to the planning authority.

The closing date for submissions is 28 May 2001.

Any submission you may wish to make about this Amendment should be in writing and must be sent to: Roger Collins, Manager Economic & Environmental Planning, Manningham City Council, P.O. Box 1, Doncaster, Vic. 3108.

JOHN BENNIE
Chief Executive

Planning and Environment Act 1987
MORELAND PLANNING SCHEME
Notice of Amendment
Amendment C7

Moreland City Council has prepared Amendment C7 to the Moreland Planning Scheme.

The Amendment rezones 1.922 hectares of land lying east of the former Pentridge Prison complex between Bell Street and Murray Road, known as Crown Allotment 17, Section 2, Township of Coburg, Parish of Jika Jika, from Public Use Zone 2 to Residential 1 Zone. Owned by the Department of Education as part of the Moreland City College, it has been identified for sale for residential purposes, to become part of the new Pentridge Village residential subdivision. The area affected is shown on the map forming part of this amendment.

A copy of the Amendment can be inspected, free of charge, during office hours, at the Department of Infrastructure, Customer Service Centre, Upper Plaza, Nauru House, 80 Collins Street, Melbourne; the Department of Infrastructure North West Metropolitan Office, 499 Ballarat Road, Sunshine; or the offices of the Moreland City Council, 90 Bell Street, Coburg.

Submissions about the Amendment must be sent to: Moreland City Council, City Strategy Department, Locked Bag 10, Moreland, Vic. 3058 by 29 May 2001.

ADRIAN ROBB
Director City Strategy
Moreland City Council

Environment Protection Act 1970

ACT NO. 8056

Grant of Accreditation

EPA Victoria, under section 26B of the **Environment Protection Act 1970**, granted accreditation on 10 April 2001 to the following licence holder –

Ford Motor Company of Australia Ltd, in respect of its Geelong Manufacturing Plant situated at Melbourne Road, North Geelong.

WAYNE SAUNDERSON
Secretary
EPA Victoria

Penalty Interest Rates Act 1983

The penalty interest rate fixed by the Attorney-General under the **Penalty Interest Rates Act 1983**, commencing 17 April 2001 is 11.5% per annum. The rate was previously fixed at 12.3%.

Water Act 1989

GLENELG REGION WATER AUTHORITY

Notice to Extend the
Hamilton Sewerage District

Notice is hereby given that under Section 96 of the **Water Act 1989**, the Glenelg Region Water Authority proposes to extend the Hamilton Sewerage District.

The proposal for the extensions to the District is available for inspection, free of charge, at the Glenelg Region Water Authority Business Centre, 66 Gray Street, Hamilton.

Submissions on the proposal, addressed to the General Manager, are invited and will be received up until 2.00 p.m. on Monday 28 May 2001 at the Office of Glenelg Region Water Authority, 66 Gray Street, (P.O. Box 107, Hamilton 3300). Submissions should set out the grounds for any objection to the proposal.

Further information may be obtained by contacting Mr Brian Jenkins, Manager Engineering Services, on 5551 0400.

Petroleum (Submerged Lands) Act 1967

COMMONWEALTH OF AUSTRALIA

Notice of Invitation of Application for Exploration Permits

I, the Delegate of the Designated Authority for and on behalf of the Commonwealth–Victoria Offshore Petroleum Joint Authority, acting pursuant to Section 20(1) of the **Petroleum (Submerged Lands) Act 1967** of the Commonwealth of Australia, hereby invite applications for the grant of exploration permits in respect of the following blocks within the area as described in the following schedule.

The block description of the areas in the 2001 release are based on the Australian Surveying and Land Information Group (AUSLIG) ‘Australian Maritime Boundaries Information System’ Dataset of 2000. AUSLIG released this revised Dataset in January 2001. The Dataset defines the State/Commonwealth jurisdictional boundaries over coastal waters.

SCHEDULE

(The references hereunder are to the names of map sheets of 1:100,000 series and to the numbers of the graticular sections shown thereon).

Area V01-1**Map Sheet SJ 54 (Hamilton)**

2194(part)	2195	2196	2265(part)	2266(part)	2267
2268	2269	2270	2336(part)	2337(part)	2338
2339	2340	2341	2342	2343	2344
2407(part)	2408(part)	2409	2410	2411	2412
2413	2414	2415	2416	2417	2479(part)
2480	2481	2482	2483	2484	2485
2486	2487	2488	2489	2554	2555
2556	2557	2558	2559	2560	2561
2628	2629	2630	2631	2632	2633
2703	2704	2705	2777		

Assessed to contain 58 graticular blocks

Area V01-2**Map Sheet SJ 54 (Hamilton)**

1989(part)	1990(part)	1991(part)	2061(part)	2062	2063(part)
2064(part)	2130(part)	2131(part)	2132(part)	2133(part)	2134
2135	2136(part)	2202	2203	2204	2205
2206	2207	2208	2274	2275	2276
2277	2278	2279	2280	2346	2347
2348	2349	2350	2351	2352	2418
2419	2420	2421	2422	2423	2424
2494	2495	2496			

Assessed to contain 45 graticular blocks

Area V01-3**Map Sheet SJ 54 (Hamilton)**

2490	2491	2492	2493	2562	2563
2564	2565	2566	2567	2568	2569

2570	2634	2635	2636	2637	2638
2639	2640	2641	2642	2643	2644
2706	2707	2708	2709	2710	2711
2712	2713	2714	2715	2716	2717
2778	2779	2780	2781	2782	2783
2784	2785	2786	2787	2788	2789
2790(part)	2851	2852	2853	2854	2855
2856	2857	2858	2859	2860	2861(part)
2862(part)	2924	2925	2926	2927	2928
2929	2930	2931	2932(part)	2933(part)	2998
2999	3000	3001	3002	3003	3004(part)
3071	3072	3073	3074	3075(part)	3076(part)
3145	3146(part)	3147(part)			

Assessed to contain 87 graticular blocks

Area V01-4**Map Sheet SJ 55 (Melbourne)**

1992	2061	2062	2063	2064	2065
2066	2136	2137	2138	2139	

Assessed to contain 11 graticular blocks

APPLICATIONS

Applications lodged under Section 20 of the **Petroleum (Submerged Lands) Act 1967** are required to be made in the approved form and should be accompanied by:

- (a) Details of –
- (i) the applicant's technical assessment of the petroleum potential of the area, including the concepts underlying its proposed exploration program, with sufficient detail to support that program;
 - (ii) the applicant's minimum guaranteed proposal (including indicative minimum expenditure) for exploration wells to be drilled, 3D and 2D seismic and other surveying activities, data evaluation and other work, for each year of the first three years of the permit term. This proposal, to be known as the minimum guaranteed work program, should comprise work expected to involve a substantial exploration component – normally, appraisal work should not be included;
 - (iii) the applicant's proposal (including indicative minimum expenditure) for exploration wells to be drilled, 3D and 2D seismic and other surveying activities, data evaluation and other work, for each of the three remaining years of the permit term. This proposal, to be known as the secondary work program, should comprise work expected to involve a substantial exploration component – normally; appraisal work should not be included.
- (b) Particulars of –
- (i) the technical qualifications of the applicant and of its key employees;
 - (ii) the technical advice available to the applicant;
 - (iii) the financial resources available to the applicant, including evidence of the applicant's ability to fund the work program proposed, a statement of other exploration commitments over the next six years, and a copy of the latest annual report and quarterly reports for each applicant company;
 - (iv) where relevant, the viability of the consortium lodging the application, including evidence that a satisfactory settlement has been, or can be, reached on the Joint Operating Agreement (a copy of a signed Heads of Agreement Dealing will generally suffice); and

- (v) the percentage participation interest of each party to the application.
- (c) Such other information as the applicant wishes to be taken into account in consideration of the application.
- (d) Each application must be accompanied by a fee of A\$3,000, payable to Commonwealth of Australia through an Australian bank or bank cheque.

Further details of the work program bidding system outlined above, including the criteria for assessment of applications and the conditions to apply following the award of the permit, are available from the Manager Minerals and Petroleum Regulation, Department of Natural Resources and Environment Melbourne and from the Petroleum Division, Department of Industry, Science and Resources in Canberra.

It should be noted that any income derived in the future from the recovery of petroleum from this area would be subject to the Commonwealth Government's Resource Rent Tax.

Availability of Data

Copies of the basic exploration data pertaining to the blocks comprising this notice and, Department of Natural Resources and Environment prepared prospectivity packages may be purchased from the Petroleum Development Branch, 7th Floor, 250 Victoria Parade, East Melbourne, Victoria 3002, telephone 03 9412 5085.

Change in Approval Process

Pursuant to Instrument of Delegation dated 16 January 2000, the Manager, Minerals and Petroleum Regulation, Department of Natural Resources and Environment is the Delegate of the Designated Authority representing Victoria in the Commonwealth-Victoria Offshore Petroleum Joint Authority (which is jointly responsible for the assessment of applications).

Closing Dates and Lodgment of Applications

Applications must be lodged by 4:00 PM on Thursday, 11 April 2002 together with the relevant data should be submitted to the:

Tender Box

Department of Natural Resources and Environment
Ground Floor, 240 Victoria Parade
East Melbourne, Victoria, 3002
Attn: Senior Petroleum Tenements Officer
Minerals and Petroleum Regulation.

The following special instructions should be observed:

- Two copies of the application and supporting data, together with a fee of \$3,000 payable to the Commonwealth of Australia through an Australian Bank or by bank cheque, should be enclosed in an envelope or package.
- The application should then be sealed and clearly marked "Application for Area V-002 Commercial-in-Confidence".
- This envelope or package should then be enclosed in a plain covering envelope or package and delivered by hand or posted to the relevant address above.

Made under the **Petroleum (Submerged Lands) Act 1967** of the Commonwealth of Australia
Dated 23 April 2001

ROBERT KING
Manager, Minerals and Petroleum Regulation
Delegate of the Designated Authority

Petroleum Act 1998
STATE OF VICTORIA

Notice of Invitation of Application for Onshore Otway Basin Petroleum Exploration Permits

Applications are hereby invited for the grant of Petroleum Exploration Permits under Section 19 of the **Petroleum Act 1998** in respect of the three onshore areas designated as VIC/O-01(1), VIC/O-01(2) and VIC/O-01(3) in Eastern Otway Basin in the region extending from Colac to the Bellarine Peninsula in the State of Victoria.

DESCRIPTION OF AREAS

Area VIC/O-01(1) comprises 42 graticular blocks equal to 2827 sq. km., Area VIC/O-01(2) comprises 33 graticular blocks equal to 1583 sq. km. and Area VIC/O-01(3) comprises 23 graticular blocks equal to 1055 sq. km. as shown on the map.

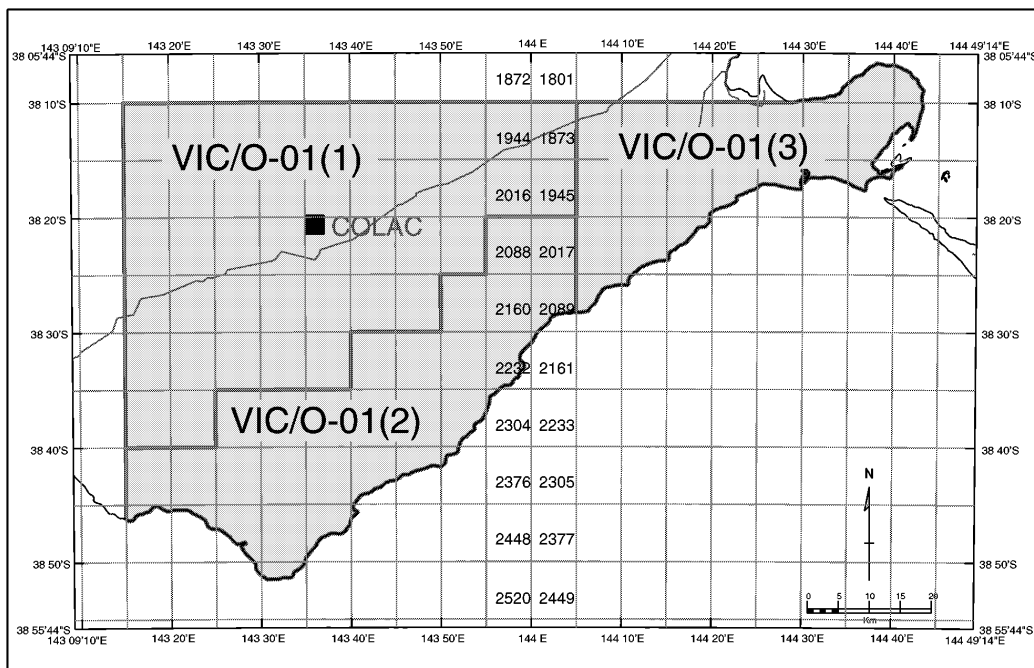

CONDITIONS OF APPLICATION

Applications shall be submitted in accordance with the provisions of Part 3, Exploration Permits, and Part 7, Provisions Applying to Authorities Generally, of the **Petroleum Act 1998** No. 96/1998 under which the Minister proposes to issue Petroleum Exploration Permits to the successful applicant. Full details of the proposed Exploration Program being offered and covering a period of tenure of five (5) years with listings of the key objectives of the first three years of the work program, for the purpose of section 27 of the Act, should be provided.

Applicants should note that the areas are offered without implementation of the 'right to negotiate' provisions contained in Part 2, Division 3, Subdivision B of the **Native Title Act 1993** and the offer contained in this Notice does not constitute a representation by the Crown or any of its officers or employees that the offer does not affect Native Title. The offer is invalid if it impacts on Native Title.

The successful applicant would be required, where appropriate, to comply with Native Title processes. If the processes are applicable, the applicant will progress any requirements to resolve Native Title issues. The Department will require periodic progress reports with respect to these processes.

Neither the Crown nor any of its officers or employees will be responsible for any liability for damages or losses suffered by a successful tenderer, who becomes a permit holder, as a result of the invalidity of any Petroleum Exploration Permit issued, due to the existence of Native Title.

SELECTION CRITERIA

Full details of the proposed exploration program being offered and covering a period of tenure of five (5) years should be provided. The factors that will be considered in assessing applications will be the key objects of the work program for the first three years of the five-year term and the financial and technical resources available to the applicant. Applicants should make themselves familiar in particular with sections 18–27 and 96–99 of the **Petroleum Act 1998**.

LODGMET OF APPLICATIONS AND CLOSING DATE

Applications addressed to the Minister for Energy and Resources together with the relevant data must be lodged by 4:00 PM on Thursday, 11 April 2002 and submitted to the:

Tender Box
Department of Natural Resources and Environment
Ground Floor, 240 Victoria Parade
East Melbourne, Victoria, 3002
Attn: Senior Petroleum Tenements Officer
Minerals and Petroleum Regulation.

The following special instructions should be observed:

- Two copies of the application and supporting data must be submitted.
- The application should then be sealed and clearly marked 'Application for Area VIC/O–01(?) Commercial-in-Confidence'.
- This envelope or package should then be enclosed in a plain covering envelope or package and delivered by hand or posted to the address above, marked Attn: Senior Petroleum Tenements Officer, Minerals and Petroleum Regulation.

Dated 23 April 2001

DAVID LEA
Executive Director, Minerals and Petroleum
Pursuant to the Instrument of Delegation dated 28/09/2000

Victoria Racing Club Act 1871

NOTICE OF AMENDMENTS TO BY-LAWS

Notice is given that the Committee of the Victoria Racing Club pursuant to section 13 of the **Victoria Racing Club Act 1871** has resolved that the following By-Laws be amended:

The First Resolution by the Committee of the Victoria Racing Club at its meeting held on 15 December 2000 resolved that By-Law 5(a), made pursuant to the **Victoria Racing Club Act 1871**, is amended by deleting from By-Law 5(a) the words "Autumn Meeting" and inserting in replacement thereof the words "the final day of the Melbourne Cup Carnival".

The Second Resolution by the Committee of the Victoria Racing Club at its meeting held on 16 February 2001 resolved that By-Law 7 made pursuant to the **Victoria Racing Club Act 1871**, is amended by:

1. Deleting from the first paragraph of By-Law 7 the sentence reading:
"Restricted members shall pay the same annual subscription as effective members and at the time of acceptance of restricted membership shall also pay the prescribed entrance fee."
and replacing it with the sentence:
"Restricted members shall pay an entrance fee upon acceptance of restricted membership, and an annual subscription fee, in each case of such sums as are from time to time determined by the Committee."
2. Deleting from the third paragraph of By-Law 7 the words "on Derby Day and Cup Day" and inserting in their place: ", in each case on Derby Day, Oaks Day and Cup Day".

The Third Resolution by the Committee of Victoria Racing Club at its meeting held on

16 February 2001 resolved that By-Law 51 of Victoria Racing Club made pursuant to the **Victoria Racing Club Act 1871** is amended by deleting from By-Law 51 the table of tolls and charges and inserting in place thereof the following new table of tolls and charges:

Race Day	Full	Concession⁽¹⁾	Children⁽²⁾
Ascot Vale Stakes Day	\$8.00	\$4.00	*
Turnbull Stakes Day	\$8.00	\$4.00	*
Victoria Derby Day	\$27.00	\$17.00	\$5.50 ⁽³⁾
Melbourne Cup Day	\$30.00	\$19.00	\$5.50 ⁽³⁾
VRC Oaks Day	\$27.00	\$17.00	*
Stakes Day	\$15.00	\$9.00	*
New Year's Day	\$9.00	\$4.50	*
Newmarket Handicap Day	\$9.00	\$4.50	*
Australian Cup Day	\$17.00	\$9.00	*
Sires' Produce Day	\$9.00	\$4.50	*
All other racedays	\$6.50	\$3.00	*

- (1) Concession: on production of:
- (a) a valid social card evidencing the holder's current entitlement to government welfare benefit; or
 - (b) a valid student card evidencing the holder's current status as a full-time student at a recognised secondary or tertiary education institution.
- (2) Children: *
- * aged less than 16 years: no charge
 - * aged 16 or 17 years: no charge if accompanied by an adult
- (3) Children: (Derby Day and Cup Day)
- (a) aged less than 6 years: no charge
 - (b) aged less than 16 years: price shown
 - (c) aged 16 years or older: full price or concession price if eligible.

The amendments to the By-Laws were sent to the Minister for Racing on 15 March 2001, have been reviewed and have not been disallowed.

The amendments will come into operation on the date of publication of this notice in the Victoria Government Gazette.

ANDREW P. RAMSDEN
Chairman
Victoria Racing Club

Stamps Act 1958

NOTICE UNDER SECTION 40A

Pursuant to section 40A of the **Stamps Act 1958** I hereby declare and make effective from 12 April 2001, that:

AP 278 – Howard Obst trading as Tress Cox & Maddox Solicitors & Notaries

to be no longer an "authorised person" in relation to the stamping of transfers of land, mortgages, bonds, debentures and covenants, marketable securities, leases, agreements to lease, assignments or transfers of lease and instruments of settlement.

DAVID POLLARD
Commissioner of State Revenue

Geographic Place Names Act 1998

REGISTRATION OF AMENDMENT OF GEOGRAPHIC NAMES

The Registrar of Geographic Names hereby gives notice of the registration of amendment of the undermentioned place name and the definition of the boundaries.

File No.	Place Name	Proposer & Location
1637	Parts of North Melbourne and Carlton to Melbourne	City of Melbourne. As set out on the map below.

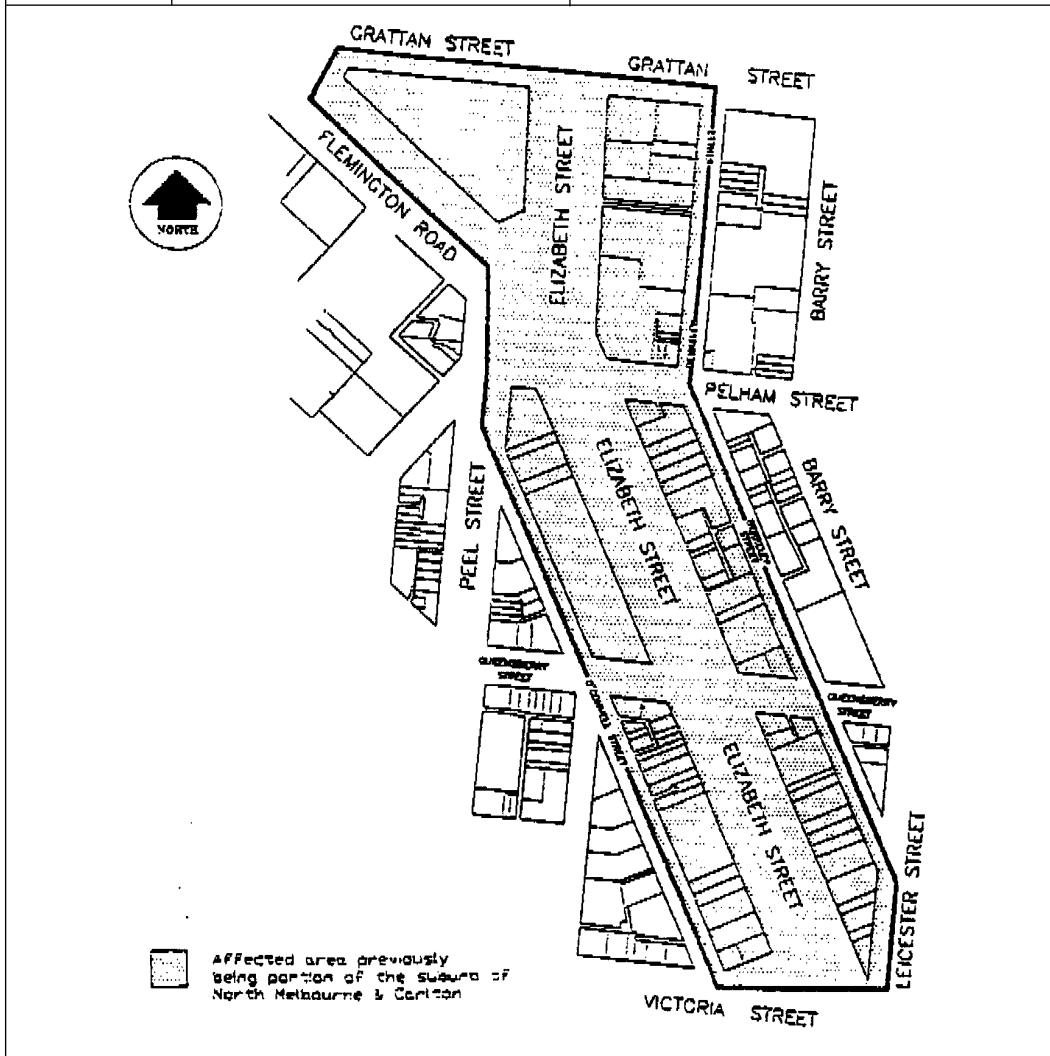

Office of the Registrar of Geographic Names
 c/-LAND VICTORIA
 7th Floor,
 436 Lonsdale Street,
 Melbourne 3000

KEITH C. BELL
 Registrar of Geographic Names

Geographic Place Names Act 1998

NOTICE OF REGISTRATION OF GEOGRAPHIC NAMES

The Registrar of Geographic Names hereby gives notice of the registration of the undermentioned place name.

File No.	Place Name	Proposer & Location
LA/12/0002	Birrarung Marr	City of Melbourne. Previously informally known as the new "riverside park", adjacent to Federation Square, Melbourne.

Office of the Registrar of Geographic Names

c/-LAND VICTORIA
7th Floor,
436 Lonsdale Street,
Melbourne 3000

KEITH C. BELL
Registrar of Geographic Names

Geographic Place Names Act 1998

NOTICE OF REGISTRATION OF GEOGRAPHIC NAMES

The Registrar of Geographic Names hereby gives notice of the registration of the undermentioned place name.

File No.	Place Name	Proposer & Location
GPN 356	The Righi Reserve	City of Banyule. Located on the corner of Eaglemont Crescent and The Righi, Eaglemont.

Office of the Registrar of Geographic Names

c/-LAND VICTORIA
7th Floor,
436 Lonsdale Street,
Melbourne 3000

KEITH C. BELL
Registrar of Geographic Names

Transport Act 1983

TOW TRUCK DIRECTORATE OF VICTORIA

Tow Truck Applications

Notice is hereby given that the following application will be considered by the Licensing Authority after 30 May 2001.

Notice of any objection to the granting of the application should be forwarded to reach the Director, Tow Truck Directorate of Victoria, Level 6, 14-20 Blackwood Street, North Melbourne (P.O. Box 666, North Melbourne 3051) not later than 24 May 2001.

It will not be necessary for interested parties to appear on the date specified, unless advised in writing.

E. J. Wiseman. Application for variation of conditions of tow truck licence number TOW056 which authorises the licensed vehicle to be managed, controlled and operated from a depot situated

at 20 Colchester Road, Rosebud to change the depot address to 8 Colchester Road, Rosebud.

Note: This licence is under consideration for transfer to Morphett BCO Pty Ltd.

Dated 26 April 2001

STEVE STANKO
Director

Transport Act 1983

VICTORIAN TAXI DIRECTORATE

Department of Infrastructure

Commercial Passenger Vehicle Applications

Notice is hereby given that the following applications will be considered by the Victorian Taxi Directorate, a division of the Department of Infrastructure after 30 May 2001.

Notice of any objection to the granting of an application should be forwarded to reach the Manager, Licensing & Certification, Victorian Taxi Directorate, Level 6, 14–20 Blackwood Street, North Melbourne (P.O. Box 666, North Melbourne 3051) not later than 24 May 2001.

Copies of objections are forwarded to the applicants.

It will not be necessary for interested parties to appear on the date specified, unless advised in writing by the Department.

K. Adams, Mornington. Application for variation of conditions of licence SV2241 which authorises the licensed vehicle to operate for the carriage of passengers from Frankston Railway Station to Wilson's Promontory and return.

To delete the above conditions and instead to operate as follows:— For the carriage of passengers on tours to various places of interest within a 200km radius of the Mornington Post Office.

Note:— Passengers will be picked up/set down within a 200km radius of the Mornington Post Office.

G. Butteriss, Geelong. Application to license one commercial passenger vehicle to be purchased in respect of a 1965 Ford convertible with seating capacity for 4 passengers to operate a service from Lot 2, Princes Highway, Waurn Ponds, for the carriage of passengers for wedding parties.

J. & J. Bougioukos & M. & C. Mylonas, Brunswick. Application for variation of conditions of licence yet to be taken up in respect of 1995 or later model Holden Suburbans, Range Rovers and Ford LTD sedans with an amended boot capacity, with seating capacity of less than 12 seats to include the ability to change the vehicle to a 1997 or later model Chrysler Grand Voyager wagon with seating capacity of less than 12 seats.

M. Oved, South Caulfield. Application to license one commercial passenger vehicle to be purchased in respect of any vehicle that meets the standards approved by the Victorian Taxi Directorate to operate as a hire car from 9 Heatherbrae Avenue, South Caulfield.

M A Pektas, Endeavour Hills. Application to license five commercial passenger vehicles to be purchased in respect of 1998 or later models Holden/Ford sedans each with seating capacity for 4 passengers to operate a service from 2 Paula Terrace, Endeavour Hills, as follows:— For the carriage of Young & Rubicam, Allianz Australia Insurance Limited, Neca Ltd and Merant Pty Ltd employees, guests and clients to corporate meetings, offices and similar related events in conjunction with Young & Rubicam, Allianz Australia Insurance Limited, Neca Ltd and Merant Pty Ltd and Quantum Corporate Cars.

Note:—

- (i) Passengers will be picked up/set down from hotels/motels and accommodation residences throughout the State of Victoria; and
- (ii) Passengers will be picked up/set down from Melbourne Airport, Tullamarine.

S. Pitrelli, Bundoora. Application to license one commercial passenger vehicle to be purchased in respect of 1989 Ford stretched limousine with seating capacity for 7 passengers to operate a service from 66 Settlement Road, Bundoora, for the carriage of passengers for wedding parties, debutante balls, school formals, funerals and anniversaries.

Dated 26 April 2001

ROBERT STONEHAM
Manager – Operations
Victorian Taxi Directorate

Planning and Environment Act 1987

BALLARAT PLANNING SCHEME

Notice of Approval of Amendment

Amendment C40

The Minister for Planning has approved Amendment C40 to the Ballarat Planning Scheme.

The Amendment comes into operation on the date this notice is published in the Government Gazette.

The Amendment establishes interim heritage controls for three precincts: Learmonth, Inner Ballarat and Buninyong, and includes policies relating to each of these areas. In accordance with an Incorporated Plan, the controls have no effect after 31 January 2002 and the operation of the policies ceases on that date.

A copy of the Amendment can be inspected, free of charge, during office hours, at the Department of Infrastructure, Planning Information Centre, Upper Plaza, Nauru House, 80 Collins Street, Melbourne and 1315 Sturt Street, Ballarat and at the offices of the Ballarat City Council, Watershed Building, Grenville Street, Ballarat.

PAUL JEROME
Executive Director
Planning, Heritage and
Building Division
Department of Infrastructure

ORDERS IN COUNCIL

BLF (De-recognition) Act 1985

EXTENSION OF PREVIOUS ORDERS

The Governor in Council under section 7 of the **BLF (De-recognition) Act 1985** orders that the following Orders made under the Act are extended in duration until 25 October 2001:

1. Order dated 13 October 1987 and published in the Government Gazette on 13 October 1987; and
2. Order dated 10 November 1987 and published in the Government Gazette on 10 November 1987; and
3. Order dated 22 December 1987 and published in the Government Gazette on 22 December 1987; and
4. Order dated 12 April 1988 and published in the Government Gazette on 12 April 1988; and
5. Order dated 17 May 1988 and published in the Government Gazette on 18 May 1988; and
6. Order dated 11 October 1988 and published in the Government Gazette on 12 October 1988; and
7. Order dated 21 March 1989 and published in the Government Gazette on 22 March 1989; and
8. Order dated 12 September 1989 and published in the Government Gazette on 13 September 1989; and
9. Order dated 20 February 1990 and published in the Government Gazette on 21 February 1990; and
10. Order dated 7 August 1990 and published in the Government Gazette on 8 August 1990; and
11. Order dated 22 January 1991 and published in the Government Gazette on 23 January 1991; and
12. Order dated 16 July 1991 and published in the Government Gazette on 17 July 1991; and
13. Order dated 26 November 1991 and published in the Government Gazette on 27 November 1991; and
14. Order dated 12 May 1992 and published in the Government Gazette on 13 May 1992; and
15. Order dated 27 October 1992 and published in the Government Gazette on 28 October 1992; and
16. Order dated 6 April 1993 and published in the Government Gazette on 8 April 1993; and
17. Order dated 28 September 1993 and published in the Government Gazette on 30 September 1993; and
18. Order dated 16 March 1994 and published in the Government Gazette on 17 March 1994; and
19. Order dated 6 September 1994 and published in the Government Gazette on 8 September 1994; and
20. Order dated 28 February 1995 and published in the Government Gazette on 2 March 1995; and
21. Order dated 22 August 1995 and published in the Government Gazette on 24 August 1995; and
22. Order dated 20 February 1996 and published in the Government Gazette on 22 February 1996; and
23. Order dated 20 August 1996 and published in the Government Gazette on 20 August 1996; and
24. Order dated 11 February 1997 and published in the Government Gazette on 13 February 1997; and
25. Order dated 5 August 1997 and published in the Government Gazette on 7 August 1997; and
26. Order dated 3 February 1998 and published in the Government Gazette on 5 February 1998; and
27. Order dated 28 July 1998 and published in the Government Gazette on 30 July 1998; and
28. Order dated 15 December 1998 and published in the Government Gazette on 17 December 1998; and
29. Order dated 8 June 1999 and published in the Government Gazette on 10 June 1999; and
30. Order dated 30 November 1999 and published in the Government Gazette on 2 December 1999; and

31. Order dated 16 May 2000 and published in the Government Gazette on 18 May 2000; and
32. Order dated 8 November 2000 and published in the Government Gazette on 9 November 2000.

Dated 24 April 2001

Responsible Minister:

MONICA GOULD

Minister for Industrial Relations

HELEN DOYE

Clerk of the Executive Council

Plant Health and Plant Products Act 1995

DECLARATION OF EXOTIC PLANT
DISEASES

The Governor in Council under section 5 of the **Plant Health and Plant Products Act 1995** declares the following plant diseases, to be exotic diseases for the purposes of section 3 of the Act—

Asparagus rust (*Puccinia asparagi*)

Asparagus stem blight (*Phomopsis asparagi*)

Dated 24 April 2001

Responsible Minister

KEITH HAMILTON MP

Minister for Agriculture

HELEN DOYE

Clerk of the Executive Council

FINANCIAL MANAGEMENT
REGULATIONS 1994

Authorisation of Expenditure of a
Royal Commission
Order in Council

The Governor in Council, under Regulation 11 of the Financial Management Regulations 1994, increases the maximum amount which the Metropolitan Ambulance Service Royal Commission, appointed and constituted pursuant to Section 88B of the **Constitution Act 1975** on 21 December 1999, is authorised to incur to \$17,300,000.

Dated 24 April 2001

Responsible Minister:

LYNNE KOSKY MP

Minister for Finance

HELEN DOYE

Clerk of the Executive Council

Land Act 1958

APPROVAL BY THE GOVERNOR IN
COUNCIL TO THE SALE OF CROWN
LAND BY PRIVATE TREATY

Order in Council

The Governor in Council, pursuant to Sections 99A(1)(a) & 99A(2) of the **Land Act 1958**, approves the sale by private treaty of the Crown land described below.

Property Address: Britannia Creek Road, Wesburn.

Crown Description: Allotment 258B, Parish of Warburton.

Dated 24 April 2001

Responsible Minister:

LYNNE KOSKY MP

Minister for Finance

HELEN DOYE

Clerk of the Executive Council

Crown Land (Reserves) Act 1978

NOTICE OF INTENTION TO REVOKE
TEMPORARY RESERVATIONS

The Governor in Council under section 10 of the **Crown Land (Reserves) Act 1978** gives notice of intention to revoke the following temporary reservations:

ACHERON — The temporary reservation by Order in Council of 1 March, 1887 of an area of 3060 square metres of land in the Parish of Acheron as a site for supply of Gravel. — (Rs 17014).

GOBUR — The temporary reservation by Order in Council of 22 April, 1986 of an area of 2.380 hectares, more or less, (incorrectly shown as 3.742 hectares, more or less, in Government Gazette of 23 April, 1986 page 1052) of land being Crown Allotment 11, Section 15, Township of Gobur, Parish of Gobur as a site for Public Purposes. — (Rs 12772).

SMYTHESDALE — The temporary reservation by Order in Council of 20 January, 1998 of an area of 50 hectares, more or less, of land in the Township of Smythesdale and Parishes of Haddon, Scarsdale and Smythesdale for Public Purposes (Rail Trail), so far only as the portion containing 126 square metres being portion of Crown Allotment 3A, Section 86, Township of Smythesdale as indicated by hatching on plan hereunder. (S297[6]) — (Rs 21140).

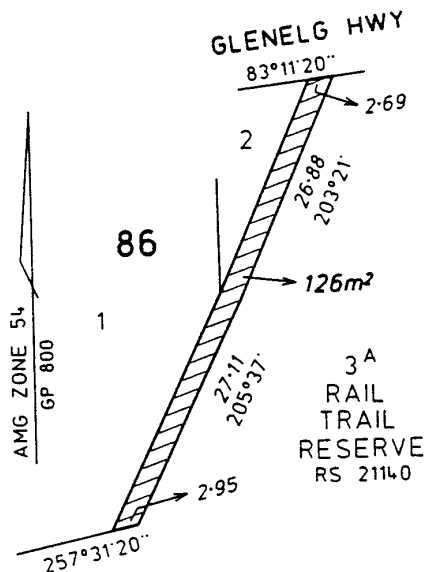

YAUGHER — The temporary reservation by Order in Council of 20 October, 1981 of an area of 5023 square metres of land being Crown Allotment 21W, Section A, Parish of Yaugher as a site for a School Camp. — (Rs 11821).

This Order is effective from the date on which it is published in the Government Gazette.

Dated 24 April 2001
 Responsible Minister
 SHERRYL GARBUTT
 Minister for Environment
 and Conservation

HELEN DOYE
 Clerk of the Executive Council

Crown Land (Reserves) Act 1978
 NOTICE OF INTENTION TO REVOKE
 TEMPORARY RESERVATIONS

The Governor in Council under section 10 of the **Crown Land (Reserves) Act 1978** gives notice of intention to revoke the following temporary reservations:

GLENROWEN — The temporary reservation by Order in Council of 12 October, 1954 of an area of 3238 square metres of land in Section 34, Township of Glenrowen, Parish of Glenrowen as a site for Police purposes. — (Rs 7303).

NUNAWADING — The temporary reservation by Order in Council of 18 January, 1949 of an

area of 1482 square metres of land in the Parish of Nunawading as a site for Police purposes, so far only as the portion containing 224 square metres as indicated by hatching on plan hereunder. (N79[10]) — (Rs 6319)

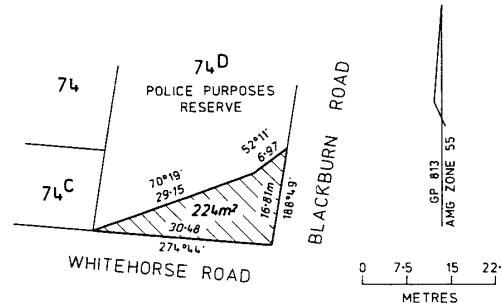

This Order is effective from the date on which it is published in the Government Gazette.

Dated 24 April 2001
 Responsible Minister
 SHERRYL GARBUTT
 Minister for Environment
 and Conservation

HELEN DOYE
 Clerk of the Executive Council

Crown Land (Reserves) Act 1978
 REVOCATION OF TEMPORARY
 RESERVATIONS

The Governor in Council under section 10 of the **Crown Land (Reserves) Act 1978** revokes the following temporary reservations:

MORTLAKE — The temporary reservation by Order in Council of 21 February, 1870 of an area of 8094 square metres of land in the Parish of Mortlake (formerly part of Crown Allotment 1 of Section 18) as a site for Common School purposes. — (Rs 43095).

PIMPINIO — The temporary reservation by Order in Council of 14 February, 1876 of an area of 2.023 hectares of land in the Township of Pimpinio, Parish of Wail as a site for Public purposes (State School). — (Rs 6633).

WA-DE-LOCK — The temporary reservation by Order in Council of 4 September, 1893 of an area of 8094 square metres of land in the Parish of Wa-de-lock as a site for Supply of Stone. — (Rs 2534).

WA-DE-LOCK — The temporary reservation by Order in Council of 14 March, 1979 of an area of 2021 square metres of land being Crown Allotment 1C, Section 2, Parish of Wa-de-lock as a site for Supply of Stone. — (Rs 10508).

This Order is effective from the date on which it is published in the Government Gazette.

Dated 24 April 2001

Responsible Minister
SHERRYL GARBUTT
 Minister for Environment
 and Conservation

HELEN DOYE
 Clerk of the Executive Council

Crown Land (Reserves) Act 1978
 REVOCATION OF TEMPORARY
 RESERVATIONS

The Governor in Council under section 10 of the **Crown Land (Reserves) Act 1978** revokes the following temporary reservations:

BALLARAT — The temporary reservation by Order in Council of 6 May, 1879 of an area of 4655 square metres of land in Section 4A, Township of Ballarat, (formerly in Section C, City of Ballarat) as a site for the use of the Police Department, revoked as to part by various Orders, so far as the balance remaining containing 3207 square metres, more or less. — (Rs 3109).

BALLARAT — The temporary reservation by Order in Council of 30 September, 1941 of an area of 2327 square metres of land in Section 4A, Township of Ballarat (formerly City of Ballarat) as a site for Public Offices and Approaches thereto. — (Rs 5285).

BEECHWORTH — The temporary reservation by Order in Council of 28 November, 1961 of an area of 8.802 hectares, more or less, of land in the Township of Beechworth, Parish of Beechworth as a site for Public Purposes, revoked as to part by Order in Council of 2 March, 1965 so far only as the portion containing 617 square metres, more or less, as indicated by hatching on plan published in the Government Gazette on 15 March, 2001 page 459. — (Rs 3867).

BEECHWORTH — The temporary reservation by Order in Council of 22 July, 1929 of an area of 2.226 hectares of land in the Township of Beechworth, Parish of Beechworth as a site for Public Purposes (State School Forest Plantation). — (Rs 3881).

This Order is effective from the date on which it is published in the Government Gazette.

Dated 24 April 2001

Responsible Minister
SHERRYL GARBUTT
 Minister for Environment
 and Conservation

HELEN DOYE
 Clerk of the Executive Council

Crown Land (Reserves) Act 1978
 TEMPORARY RESERVATION OF CROWN
 LANDS

The Governor in Council under section 4(1) of the **Crown Land (Reserves) Act 1978** temporarily reserves the following Crown lands which in his opinion are required for the purposes mentioned:—

**MUNICIPAL DISTRICT OF THE
 INDIGO SHIRE COUNCIL**

BEECHWORTH — Public purposes, total area 6.85 hectares, more or less, being Crown Allotments 14E and 19A, Section 24A, and Crown Allotments 21A and 21B, Section H2, Township of Beechworth, Parish of Beechworth as indicated by hatching on plans hereunder. (B348[8] & [9]) — (Rs 3867).

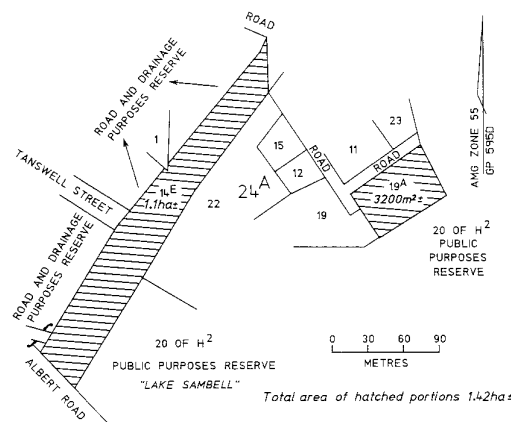

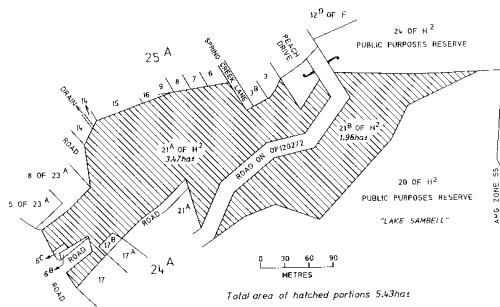

MUNICIPAL DISTRICT OF THE CITY OF GREATER BENDIGO

BENDIGO — Public Recreation, 1162 square metres being Crown Allotment 186G, Section C, At Bendigo, Parish of Sandhurst as indicated by hatching on plan hereunder. (S372[124]) — (Rs 3458).

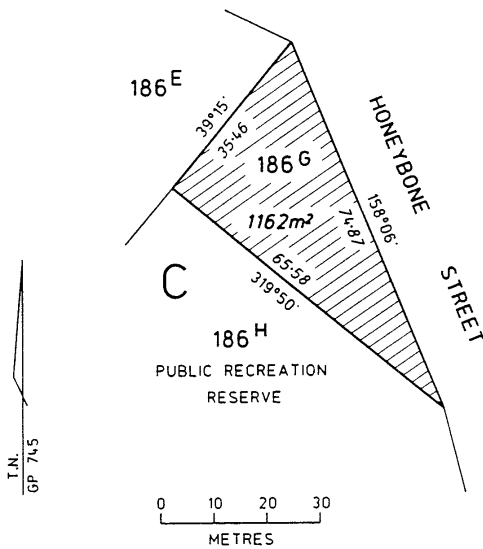

MUNICIPAL DISTRICT OF THE GREATER GEELONG CITY COUNCIL

CONEWARRE — Public purposes, 8.8 hectares, more or less, being Crown Allotment 3, Section 4A, Parish of Conewarre as shown on Plan No. LEGL./01-10 lodged in the Central Plan Office. — (0700279).

MUNICIPAL DISTRICT OF THE GREATER GEELONG CITY COUNCIL

FYANSFORD — Public purposes, all the Crown land in the Township of Fyansford included within the area coloured purple on Plan No. LEGL./01-09 lodged in the Central Plan

Office and not having been previously permanently reserved for Public purposes by Order in Council 23 May, 1881 (vide Government Gazette of 27 May, 1881 — page 1389). — (0700279).

MUNICIPAL DISTRICT OF THE LA TROBE SHIRE COUNCIL

MARYVALE — Public purposes (Health purposes), 1975 square metres being Crown Allotment 69R1, Parish of Maryvale as shown on Certified Plan No.119423 lodged in the Central Plan Office. — (Rs 10149).

MUNICIPAL DISTRICT OF THE GLENELG SHIRE COUNCIL

PORTLAND — Public purposes (Kindergarten), 375 square metres, being Crown Allotment 46C, Section D, Township of Portland, Parish of Portland as indicated by hatching on plan hereunder. (P69[10]) — (Rs 8622).

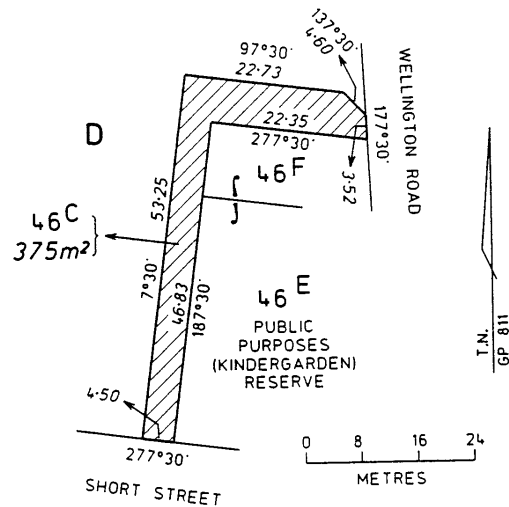

MUNICIPAL DISTRICT OF THE BASS COAST SHIRE COUNCIL

VENTNOR — Conservation of an area of natural interest, 14.10 hectares, more or less, being Crown Allotment 2, Section 13 and Crown Allotment 15, Section 7, Township of Ventnor, Parish of Phillip Island as indicated by hatching on plan hereunder. (V10[1]) — (Rs 10443).

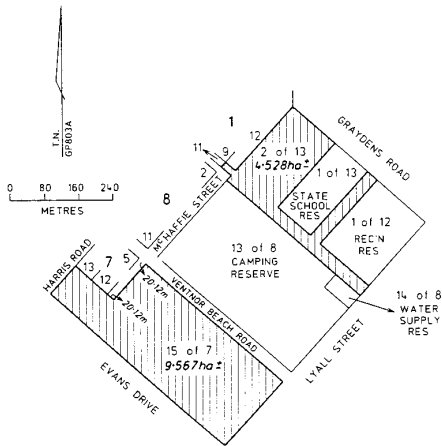

TOTAL AREA OF HATCHED PORTIONS IS 14.10ha.

This Order is effective from the date on which it is published in the Government Gazette.

Dated 24 April 2001

Responsible Minister
SHERRYL GARBUTT
Minister for Environment
and Conservation

HELEN DOYE
Clerk of the Executive Council

Land Act 1958

CLOSURE OF UNUSED ROADS

The Governor in Council under section 349 of the **Land Act 1958** and with the concurrence in writing of the municipalities in which the roads are situated closes the following unused roads:

**MUNICIPAL DISTRICT OF THE
MILDURA RURAL CITY COUNCIL**

BERROOK — The road in the Parish of Berrook as indicated by hatching on plan hereunder. (B786[11]) — (01/972).

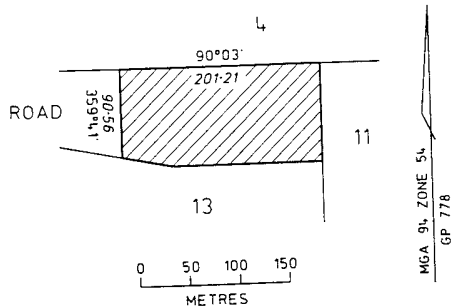

**MUNICIPAL DISTRICT OF THE
BASS COAST SHIRE COUNCIL**
VENTNOR — The roads in the Township of Ventnor, Parish of Phillip Island as indicated by hatching on plan hereunder. (V10[1]) — (Rs 10443).

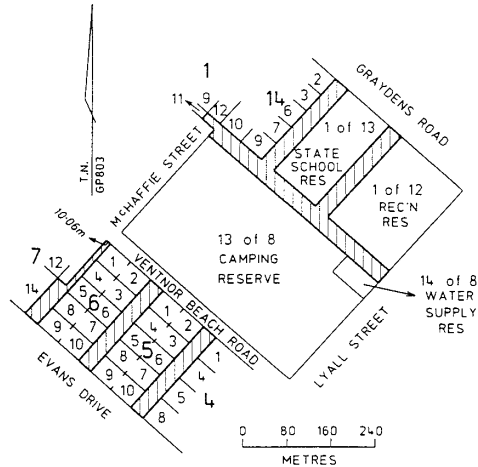

This Order is effective from the date on which it is published in the Government Gazette.

Dated 24 April 2001

Responsible Minister
SHERRYL GARBUTT
Minister for Environment
and Conservation

HELEN DOYE
Clerk of the Executive Council

Land Act 1958

CLOSURE OF UNUSED ROADS

The Governor in Council under section 349 of the **Land Act 1958** and with the concurrence in writing of the municipalities in which the roads are situated and the owners of land adjoining those roads closes the following unused roads:

**MUNICIPAL DISTRICT OF THE
INDIGO SHIRE COUNCIL**

CHILTERN WEST — The road in the Parish of Chiltern West shown as Crown Allotment 3C, Section U1 on Original Plan No. 121205 lodged in the Central Plan Office. — (L8-3051).

MUNICIPAL DISTRICT OF THE
MOYNE SHIRE COUNCIL

CLONLEIGH — The road in the Parish of Clonleigh as indicated by hatching on plan hereunder. (C361[2]) — (03/P044214).

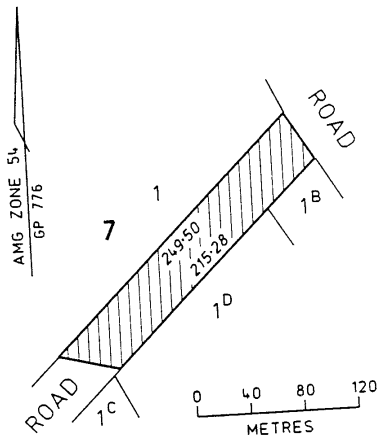

MUNICIPAL DISTRICT OF THE
GREATER GEELONG CITY COUNCIL

MOOLAP — The road in the Parish of Moolap as indicated by hatching on plan hereunder. (3153) — (L1-4358).

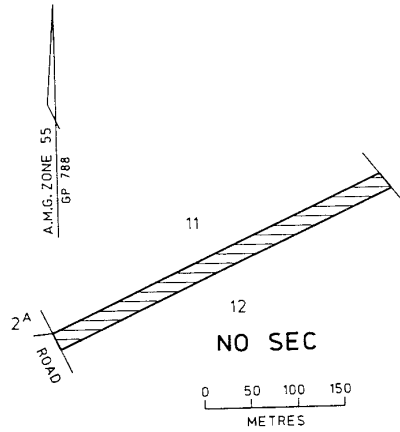

MUNICIPAL DISTRICT OF THE
EAST GIPPSLAND SHIRE COUNCIL

GELANTIPY EAST — The road in the Parish of Gelantipy East as indicated by hatching on plan hereunder. (G223[7]) — (16/P322477).

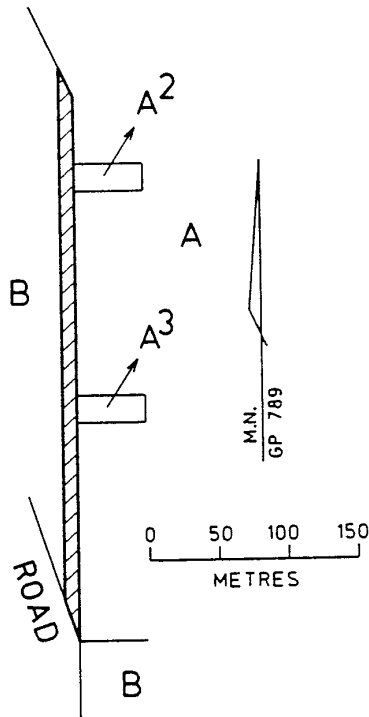

MUNICIPAL DISTRICT OF THE
CITY OF GREATER BENDIGO

RAYWOOD and NEILBOROUGH — The road in the Township of Raywood and the Parish of Neilborough as indicated by hatching on plan hereunder. (R57[3]) — (06/07823).

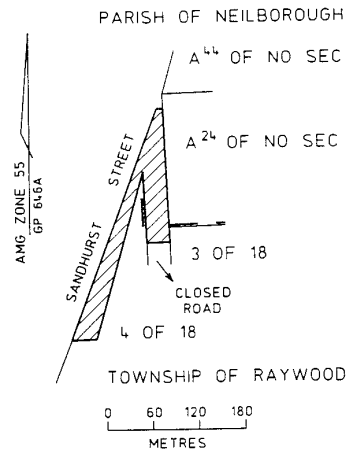

This Order is effective from the date on which it is published in the Government Gazette.

Dated 24 April 2001

Responsible Minister
SHERRYL GARBUTT
Minister for Environment
and Conservation

HELEN DOYE
Clerk of the Executive Council

Land Act 1958
AMENDMENT TO TOWNSHIP
BOUNDARIES

The Governor in Council under Section 25(3)(d) of the **Land Act 1958** amends the following Township boundaries:—

RAYWOOD — Township of Raywood proclaimed on 14 May, 1918 and rescinded as to part by Proclamation of 2 March, 1920, by the addition thereto of the area indicated by diagonal hatching on plan hereunder. (R57[3]) — (LA/17/0006).

This Order is effective from the date on which it is published in the Government Gazette.

Dated 24 April 2001
 Responsible Minister
SHERRYL GARBUTT
 Minister for Environment
 and Conservation

HELEN DOYE
 Clerk of the Executive Council

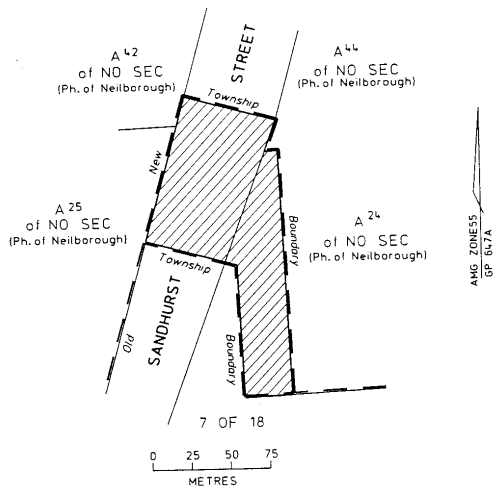

WANDILIGONG — Township of Wandiligong proclaimed on 19 May, 1954 by the addition thereto of the area indicated by diagonal hatching on plan hereunder. (W301[A2]) — (11/L8-6682).

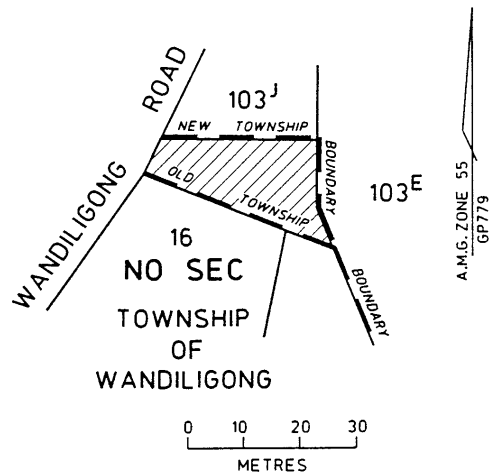

Crown Land (Reserves) Act 1978INCORPORATION OF COMMITTEES OF MANAGEMENT
AND APPOINTMENT OF CHAIRPERSONS

The Governor in Council under section 14A(1) of the **Crown Land (Reserves) Act 1978**, being satisfied that it is in the public interest to declare to be corporations the Committees of Management appointed under section 14(2) of the Act of the lands described in Column 1 of the schedule hereunder:—

(a) declares that the Committees of Management shall be corporations;

(b) assigns the names shown in Column 2 to the corporations; and

under section 14B(3) of the Act, appoints the persons listed in Column 3 to be Chairpersons of the corporations.

SCHEDULE

Column 1 Reserve details	Column 2 Corporate name	Column 3 Chairperson
Noradjuha Recreation Reserves – The lands in the Township of Noradjuha temporarily reserved for Public Recreation by Orders in Council of 11 July, 1922 (vide Government Gazette of 19 July, 1922 – page 1831); 30 December, 1927 (vide Government Gazette of 6 January, 1928 – page 30) and 4 September, 1956 (vide Government Gazette of 12 September, 1956 – page 4795) [Rs 2536]	Noradjuha Recreation Reserve Committee Incorporated	Allan MACINNES
Dunrobin Public Hall and Recreation Reserves – The lands in the Parish of Casterton temporarily reserved for Public Hall by Order in Council of 19 August, 1913 (vide Government Gazette of 27 August, 1913 – page 3929) and for public purposes and recreation by Order in Council of 14 March, 2001 (vide Government Gazette of 15 March, 2001 – page 461) [Rs 43108]	Committee of Management of Dunrobin Public Hall and Reserve Incorporated	Jeoff HORTLE
Wal Wal Public Hall and Recreation Reserve – The lands in the Township of Wal Wal temporarily reserved for Public Hall and Public Recreation by Order in Council of 15 November, 1966 (vide Government Gazette of 23 November, 1966 – page 4008) [Rs 5753]	Wal Wal Recreation Reserve Incorporated	Ken MAHER
Harcourt Recreation Reserve – The remaining land in the Township of Harcourt temporarily reserved for Public Recreation by Order in Council of 13 February, 1884 (vide Government Gazette of 16 February, 1884 – page 573) [Rs 1799]	Harcourt Recreation Reserve Committee Incorporated	Ronald DOUGLAS

774 G 17 26 April 2001

Victoria Government Gazette

This Order is effective from the date on which it is published in the Government Gazette.

Dated 24 April 2001

Responsible Minister

SHERRYL GARBUTT

Minister for Environment and Conservation

HELEN DOYE

Clerk of the Executive Council

**SUBORDINATE LEGISLATION ACT 1994
NOTICE OF MAKING OF STATUTORY
RULES**

Notice is hereby given under Section 17 (2) of the **Subordinate Legislation Act 1994** of the making of the following Statutory Rules:

32. *Statutory Rule:* Supreme Court (Sheriff's Fees) (Amendment) Regulations 2001
Authorising Act: Supreme Court Act 1986
Date of making: 24 April 2001
33. *Statutory Rule:* Supreme Court (Fees) (Amendment) Regulations 2001
Authorising Act: Supreme Court Act 1986
Date of making: 24 April 2001
34. *Statutory Rule:* County Court (Court Fees) (Amendment) Order 2001
Authorising Act: County Court Act 1958
Date of making: 24 April 2001
35. *Statutory Rule:* County Court (Bailiff's Fees) (Amendment) Order 2001
Authorising Act: County Court Act 1958
Date of making: 24 April 2001
36. *Statutory Rule:* Conservation, Forests and Lands (Infringement Notice) (Fisheries) Regulations 2001
Authorising Act: Conservation, Forests and Lands Act 1987
Date of making: 24 April 2001

Retail price will vary according to the number of pages in each special or periodical gazette. The table below sets out the prices that apply.

<i>Price Code</i>	<i>No. of Pages (Including cover and blank pages)</i>	<i>Price</i>
A	1-16	\$2.90
B	17-32	\$4.30
C	33-48	\$5.90
D	49-96	\$9.15
E	97-144	\$11.85
F	145-192	\$14.00
G	193-240	\$16.15
H	241-288	\$17.20
I	289-352	\$19.35
J	353-416	\$22.60
K	417-480	\$25.80
L	481-544	\$30.10
M	545-608	\$34.40
N	609-672	\$38.70
O	673-736	\$43.00
P	737-800	\$47.30

ADVERTISERS PLEASE NOTE

As from 26 April 2001

The last Special Gazette was No. 58 dated 24 April 2001

The last Periodical Gazette was No. 1 dated 22 June 2000

CONTENTS

	Page
Estates of Deceased Persons	711
Government and Outer Budget Sector	
Agencies Notices	745
Orders in Council—	765
Acts — BLF (De-recognition); Plant Health and Plant Products; Constitution; Land; Crown Land (Reserves)	
Private Advertisements	711
Proclamations	744

The Victoria Government Gazette is published by The Craftsman Press Pty. Ltd. with the authority of the Government Printer for the State of Victoria
© State of Victoria 2001

ISSN 0819-5471

This publication is copyright. No parts may be reproduced by any process except in accordance with the provisions of the Copyright Act.

Products and services advertised in this publication are not endorsed by The Craftsman Press Pty. Ltd. or the State of Victoria and neither of them accepts any responsibility for the content or the quality of reproduction. The Craftsman Press Pty. Ltd. reserves the right to reject any advertising material it considers unsuitable for government publication.

Address all enquiries to the Government Printer for the State of Victoria
Government Information and Communications Branch
Department of Premier and Cabinet
Level 3, 356 Collins Street
Melbourne 3000
Victoria Australia

RETAIL SALES

Information Victoria Bookshop
356 Collins Street Melbourne 3000.
Telephone enquiries 1300 366 356

City Graphics
Level 1, 520 Bourke Street
Melbourne 3000
Telephone enquiries (03) 9600 0977

Recommended Retail Price \$1.70

Government and Outer Budget Sector Agencies please note:
STYLE REQUIREMENTS.

To ensure that material received can be reproduced, and that errors are minimised, the following guidelines are to be observed when submitting material by fax.

Fax resolution:

Material sent by fax should be transmitted using Fine Resolution (200 dots per inch by 200 dpi).

Font size:

Use 12 point (10 pitch) or larger.

Font Style:

Clear plain font styles, such as Helvetica, should be used.

Graphics:

Line drawings should be transmitted as large as possible to ensure clarity. Drawings up to A4 size sent by fax using Fine Resolution provide a good quality for reproduction.

Avoid:

Italics, underlining and full justification.

Ensure document is square when sending as documents that are sent skewed are difficult to read and process.

ISSN 0819-5471

