



# Victoria Government Gazette

No. G 22 Thursday 30 May 2002

**GENERAL**

## GENERAL AND PERIODICAL GAZETTE

Copy to: Gazette Officer  
The Craftsman Press Pty. Ltd.  
125 Highbury Road,  
Burwood Vic 3125  
Telephone: (03) 9926 1233  
Facsimile: (03) 9926 1292  
DX: 32510 Burwood  
Email: [gazette@craftpress.com.au](mailto:gazette@craftpress.com.au)

### Advertising Rates and Payment

#### All prices include GST

#### Private Notices

Payment must be received in advance with advertisement details.

33 cents per word – Full page \$198.00.

Additional costs must be included in prepayment if a copy of the gazette is required. Copy Prices – Page  
\$1.65 – Gazette \$3.52 – Certified copy of Gazette \$3.85  
(all prices include postage). **Cheques should be made payable to The Craftsman Press Pty. Ltd.**

#### Government and Outer Budget Sector Agencies Notices

Not required to prepay.

Advertisements may be faxed or sent via email with a cover sheet, marked to the attention of the Gazette Officer. Floppy Disks (Mac & PC) can also be accepted.

Costs can be calculated on the following basis:

Per Line	Typeset
Single column	\$1.71
Double column	\$3.41
Full Page	\$71.28

The Craftsman Press is pleased to offer a series of discounts from the typesetting costs.

1. Copy supplied on disk.
2. Copy supplied via email.
3. Artwork for forms and other material which require exact reproduction.

#### 1. Copy supplied on disk.

Where a disk is supplied and there is minimum alteration required, **30% off.**

Where a disk is supplied requiring extraneous matter stripped out and styles applied, **20% off.**

#### 2. Copy supplied via email.

Where a notice is sent via email and there is minimum alteration required, **25% off.**

Where email is supplied requiring extraneous matter stripped out and styles applied, **15% off.**

#### 3. Artwork for forms and other material which requires exact reproduction.

Scanning and sizing of artwork for forms, to be reproduced in page format, **35% off.**

#### Copy Deadline for General Gazette

9.30 a.m. Monday – (Private Notices)

9.30 a.m. Tuesday – (Government and Outer Budget Sector Agencies Notices)

### Advertisers should note:

- Late copy received at The Craftsman Press Pty. Ltd. after deadlines will be placed in the following issue of VGG, irrespective of any date/s mentioned in the copy (unless otherwise advised).
- Late withdrawal of advertisements (after client approval, before printing) will incur 50 per cent of the full advertising rate to cover typesetting, layout and proofreading costs.
- Proofs will be supplied only when requested or at the direction of the Gazette Officer.
- No additions or amendments to material for publications will be accepted by telephone.
- Orders in Council may be lodged prior to receiving assent with the Governor's or Clerk's signature. They will only be published once approved and signed.
- Accounts over 90 days will be issued with a letter of demand.
- Government and Outer Budget Sector Agencies please note: *See style requirements on back page.*

## SPECIAL GAZETTES

Copy to: Gazette Officer  
The Craftsman Press Pty. Ltd.  
125 Highbury Road  
Burwood Vic 3125  
Telephone: (03) 9926 1233  
Facsimile: (03) 9926 1292  
Email: [gazette@craftpress.com.au](mailto:gazette@craftpress.com.au)

### Advertising Rates and Payment

#### Private Notices

Full Page \$396.00

Payment must be received in advance with notice details.

#### Government and Outer Budget Sector Agencies Notices

	Typeset
Full Page	\$96.25

#### Note:

The after hours number for Special Gazettes is:  
Telephone: 0419 327 321

## SUBSCRIPTIONS AND RETAIL SALES

Copies of the *Victoria Government Gazette* can be purchased from The Craftsman Press Pty. Ltd. by subscription.

#### The *Victoria Government Gazette*

General and Special – \$187.00 each year

General, Special and Periodical – \$249.70 each year

Periodical – \$124.30 each year

Subscriptions are payable in advance and accepted for a period of one year. All subscriptions are on a firm basis and refunds will not be given.

**All payments should be made payable to The Craftsman Press Pty. Ltd.**

#### Subscription enquiries:

The Craftsman Press Pty. Ltd.  
125 Highbury Road, Burwood Vic 3125  
Telephone: (03) 9926 1233

# INDEX TO PRIVATE ADVERTISERS

## A

Andrew G. J. Rowan .....1068  
 Arthur J. Dines. ....1068

## B

Best Hooper .....1068  
 Bruce M. Cook & Associates .....1068

## C

Chessell Williams .....1068  
 Cornwall Stodard .....1069

## D

Dwyer Mahon & Robertson .....1069

## E

E. P. Johnson & Davies .....1069  
 Ellinghaus Weill .....1069

## F

Featherby's .....1069

## G

G. A. Black & Co. ....1070  
 G. W. H. Chambers .....1070  
 Gullaci & Gullaci .....1071

## H

Holding Redlich .....1071

## L

Littleton Hackford & D'Alessandro ....1071  
 Lucas Lawyers .....1071

## N

Nicholas O'Donohue .....1071

## O

O'Brien & Galante .....1071

## P

Pietrzak Solicitors .....1071  
 Perpetual Trustees Victoria Limited ....1072  
 Perpetual Trustees Consolidated Limited ..1072

## R

Rigby Cooke .....1072  
 Roberts Partners .....1072

## S

Sewells Larkins & McCarthy .....1072

## W

White Cleland Pty .....1073

**PUBLICATION OF THE VICTORIA GOVERNMENT GAZETTE (GENERAL)  
QUEEN'S BIRTHDAY HOLIDAY**

**Please Note:**

The Victoria Government Gazette for Queen's Birthday week will be published on **Thursday 13 June 2002**.

**Copy deadlines:**

Private Advertisements **9.30am on Friday 7 June 2002.**

Government and Outer

Budget Sector Agencies Notices **9.30am on Tuesday 11 June 2002.**

Where urgent gazettal is required after hours, arrangements should be made with the Government Gazette Officer on 0419 327 321.

JENNY NOAKES  
Government Gazette Officer

---

**PRIVATE ADVERTISEMENTS**

**DISSOLUTION OF PARTNERSHIP**

Notice is hereby given that the partnership between Ad Mag SA & NSW Pty Ltd, a wholly owned subsidiary of Trader.com (Australia) Holdings Pty Ltd, and Hallco No 40 Pty Ltd, a wholly owned subsidiary of OzEmag Holdings Pty Ltd, concerning the conduct of advertising businesses in South Australia and New South Wales has been dissolved effective 27 July 2001.

ARNOLD BLOCH LEIBLER, lawyers,  
333 Collins Street, Melbourne, Victoria.

THOMAS BARRETT BROOKS, late of 75 Roseberry Street, Hawthorn East, Victoria, retired chemist, deceased. Creditors, next-of-kin and others having claims in respect of the estate of the deceased, who died on 22 December 2001, are required by Equity Trustees Limited, ACN 004 031 298, the proving executor of the will of the deceased, to send particulars of their claims to the executor in the care of the undermentioned solicitor by 31 July 2002 after which date the executor may convey or distribute the assets having regard only to the claims of which it then has notice.

ANDREW G. J. ROWAN, solicitor,  
Level 4, 472 Bourke Street, Melbourne 3000.

JOHN DOUGLAS KREUTZER, late of Dromana Nursing Home, 6 Nepean Highway, Dromana, Victoria, retired structural engineer, deceased. Creditors, next-of-kin and others having claims in respect of the estate of the deceased, who died on 15 March 2002, are required by Equity Trustees Limited, ACN 004 031 298, the proving executor of the will of the deceased, to send particulars of their claims to the executor in the care of the undermentioned solicitor by 31 July 2002 after which date the executor may convey or distribute the assets having regard only to the claims of which it then has notice.

ANDREW G. J. ROWAN, solicitor,  
Level 4, 472 Bourke Street, Melbourne 3000.

DESPINA SIDIROPOULOS, late of 149 Gower Street, Preston, in the State of Victoria, pensioner, deceased. Creditors, next-of-kin and

others having claims in respect of the estate of the deceased, who died on 19 September 2001, are required by the administratrices, Angela Zafiris and Anna Paloubis, care of Arthur J. Dines & Co., solicitors, 2A Highlands Road, Thomastown, in the said State, to send particulars to them by 25 July 2002 after which date the administratrices may convey or distribute the assets having regard only to the claims of which they have notice.

Dated 10 May 2002

ARTHUR J. DINES & CP., solicitors,  
2A Highlands Road, Thomastown 3074.

Re: VIOLA WILSON TAIT, deceased. Creditors, next-of-kin and others having claims against the estate of VIOLA WILSON TAIT, late of 106 Leopold Street, South Yarra, Victoria, widow, deceased, who died on 6 February 2002, are required to send particulars of their claims to the executrix care of the undermentioned solicitors by 31 July 2002 after which date the executrix will proceed to distribute the assets having regard only to the claims of which she shall then have notice.

BEST HOOPER, solicitors,  
563 Little Lonsdale Street, Melbourne 3000.

Re: Estate MAVIS IRENE BEARD, deceased. Creditors, next-of-kin or others having claims in respect of the estate of MAVIS IRENE BEARD of 95 Glen Iris Road, Glen Iris, in the State of Victoria, company director, who died on 21 September 2001, are to send particulars of their claims to the personal representative/s care of the undermentioned solicitors by 31 July 2002 after which date the personal representative/s will distribute the assets having regard only to the claims of which they then had notice.

BRUCE M. COOK & ASSOCIATES,  
barristers & solicitors,  
Level 19, AMP Tower,  
535 Bourke Street, Melbourne, Vic. 3000.

Re: MARGARET GRAHAM GILL. Creditors, next-of-kin and others having claims against the estate of MARGARET GRAHAM GILL, late of Wesley Gardens, 2B Morgan

Road, Belrose, New South Wales, widow, who died on 5 January 2002, are requested to send particulars of their claims to the executors care of the undermentioned solicitors by 10 August 2002 after which date they will distribute the assets having regard only to the claims at which date they then had notice.

CHESSELL WILLIAMS, solicitors,  
379 Collins Street, Melbourne 3000.

---

VICTOR ASHTON FOX, late of 75 Nicholson Street, Carlton, Victoria, artist, deceased. Creditors, next-of-kin and others having claims in respect of the estate of the deceased, who died on 13 March 2002, are required by John Francis Chamberlin of 48 Claremont Avenue, Malvern, Victoria, the executor of the will of the said deceased, to send particulars to him at Cornwall Stodart, Level 10, 114 William Street, Melbourne by 10 August 2002 after which date the said executor may convey or distribute the assets having regard only to the claims of which he shall then have notice.

Dated 22 May 2002

CORNWALL STODARD, lawyers,  
10th Floor, 114 William Street, Melbourne.

---

Re: Estate of LEONARD EUGENE McLOUGHLAN. Creditors, next-of-kin and others having claims in respect of the estate of LEONARD EUGENE McLOUGHLAN, late of 95 Sutcliffe Street, Sea Lake, in the State of Victoria, retired, deceased, who died on 3 April 2002, are to send particulars of their claim to the executrix care of the undermentioned legal practitioners by 14 August 2002 after which date the executrix will distribute the assets having regard only to the claims of which she then has notice.

DWYER MAHON & ROBERTSON,  
legal practitioners,  
Beveridge Dome,  
194–208 Beveridge Street, Swan Hill.

---

Re: OLIVE MARGARET McFEETERS, deceased. Creditors, next-of-kin or others having claims in respect of the estate of OLIVE MARGARET McFEETERS, late of 400 Waverley Road, East Malvern 3145, retired Salvation Army officer, deceased, who died on

11 March 2002, are to send particulars of their claims to the executor care of the undermentioned solicitors by 2 August 2002 after which date the executor will distribute the assets having regard only to the claims of which the executor then has notice.

E. P. JOHNSON & DAVIES, solicitors,  
52 Collins Street, Melbourne 3000.

---

ALYDA BOSCH, late of 28 Green Street, California Gully, Bendigo, home duties, deceased. Creditors, next-of-kin and others having claims in respect of the estate of the deceased, who died on 7 February 2002, are required by the personal representative, Willi Alyda Carney of 10 High Street, Eaglehawk, to send particulars to her care of the undermentioned solicitors by 7 August 2002 after which date the personal representative may convey or distribute the assets having regard only to the claims of which she then has notice.

ELLINGHAUS WEILL, solicitors,  
79–81 Franklin Street, Melbourne 3000.

---

Estate PATRICIA AILEEN BARCLAY, deceased. Creditors, next-of-kin or others having claims in respect of the estate of PATRICIA AILEEN BARCLAY, late of 36 Genista Street, Frankston, in the State of Victoria, deceased, who died on 1 September 2001, are to send particulars of their claims to the executor care of the undermentioned solicitors by 30 July 2002 after which date the executor will distribute the assets having regard only to the claims of which she then has notice.

FEATHERBY'S, solicitors,  
1043A Point Nepean Road, Rosebud 3939.

---

Estate PHILIP WAYNE BENSON, deceased. Creditors, next-of-kin or others having claims in respect of the estate of PHILIP WAYNE BENSON, late of 18/1 Inner Harbour Drive, Patterson Lakes, in the State of Victoria, deceased, who died on 19 January 2002, are to send particulars of their claims to the administrator care of the undermentioned solicitors by 30 July 2002 after which date the administrator will distribute the assets having regard only to the claims of which he then has notice.

FEATHERBY'S, solicitors,  
1043A Point Nepean Road, Rosebud 3939.

---

Estate MARGARET ANN CIZZIO, deceased. Creditors, next-of-kin or others having claims in respect of the estate of MARGARET ANN CIZZIO, late of 63 Kennington Road, Rosebud, in the State of Victoria, deceased, who died on 8 April 2001, are to send particulars of their claims to the executor care of the undermentioned solicitors by 30 July 2002 after which date the executor will distribute the assets having regard only to the claims of which he then has notice.

FEATHERBY'S, solicitors,  
1043A Point Nepean Road, Rosebud 3939.

---

Estate GARRY JOHN CIZZIO, deceased. Creditors, next-of-kin or others having claims in respect of the estate of GARRY JOHN CIZZIO, late of 63 Kennington Road, Rosebud, in the State of Victoria, deceased, who died on 8 April 2001, are to send particulars of their claims to the executor care of the undermentioned solicitors by 30 July 2002 after which date the executor will distribute the assets having regard only to the claims of which he then has notice.

FEATHERBY'S, solicitors,  
1043A Point Nepean Road, Rosebud 3939.

---

Estate ROSE JULIA HOLDEN, deceased. Creditors, next-of-kin or others having claims in respect of the estate of ROSE JULIA HOLDEN, late of Ti Tree Gardens Aged Care Facility, 34A Balaka Street, Rosebud, in the State of Victoria, deceased, who died on 23 December 2001, are to send particulars of their claims to the executor care of the undermentioned solicitors by 30 July 2002 after which date the executor will distribute the assets having regard only to the claims of which he then has notice.

FEATHERBY'S, solicitors,  
1043A Point Nepean Road, Rosebud 3939.

---

Estate VIOLET McINTYRE, deceased. Creditors, next-of-kin or others having claims in respect of the estate of VIOLET McINTYRE, late of 2/1 McDowell Road, Rosebud, in the State of Victoria, deceased, who died on 14 September 2001, are to send particulars of their claims to the executor care of the undermentioned solicitors by 30 July 2002 after which date the executor will distribute the assets having regard only to the claims of which he then has notice.

FEATHERBY'S, solicitors,  
1043A Point Nepean Road, Rosebud 3939.

---

Estate ROBERT OWEN PALIN, deceased. Creditors, next-of-kin or others having claims in respect of the estate of ROBERT OWEN PALIN, late of 25 Station Street, Somerville, in the State of Victoria, deceased, who died on 4 March 2001, are to send particulars of their claims to the executor care of the undermentioned solicitors by 30 July 2002 after which date the administrator will distribute the assets having regard only to the claims of which he then has notice.

FEATHERBY'S, solicitors,  
1043A Point Nepean Road, Rosebud 3939.

---

Re: ISABEL SULLIVAN, deceased. Creditors, next-of-kin or others having claims in respect of the estate of ISABEL SULLIVAN, late of 1 Walker Street, Healesville, Victoria, home duties, deceased, who died on 14 November 2001, are to send particulars of their claims to the executors care of the undermentioned solicitors by 26 July 2002 after which date the executors will distribute the assets having regard only to the claims of which the executors then have notice.

G. A. BLACK & CO., , solicitors,  
222 Maroondah Highway, Healesville.

---

Re: WINIFRED ISELIN, deceased. Creditors, next-of-kin or others having claims in respect of the estate of WINIFRED ISELIN, late of 300 Springvale Road, Donvale, Victoria 3111, but formerly of 10 Kenilworth Avenue, Wonga Park, Victoria 3115, home duties, deceased, who died on 3 January 2002, are to send particulars of their claims to the executors care of the undermentioned solicitors by 26 July 2002 after which date the executors will distribute the assets having regard only to the claims of which the executors then have notice.

G. A. BLACK & CO., , solicitors,  
222 Maroondah Highway, Healesville.

---

RONALD ERNEST MAWHINNEY, late of 2 Cheltenham Road, Black Rock. Creditors, next-of-kin and others having claims in respect of the estate of the deceased, who died on 26 March 2002, are required by the trustee, care of G. W. H. Chambers, solicitor of 338 Charman Road, Cheltenham, to send particulars to her by 31 July 2002 after which date the trustee may

convey or distribute the assets, having regard only to the claims of which she then has notice.  
G.W. H. CHAMBERS, solicitor,  
338 Cheltenham Road, Cheltenham 3192.

---

ILARIO FRANCO, late of 2 Tresa Court, Reservoir 3073, in the State of Victoria, concrete contractor, deceased. Creditors, next-of-kin and others having claims in respect of the estate of the deceased, who died on 24 January 2002, are required by Nicola Franco and Giuseppe Franco, the executors of the said estate, to send particulars by 1 August 2002 to their solicitors Gullaci & Gullaci of 158 Bell Street, Coburg, after which date the executors may convey or distribute the assets, having regard only to the claims of which they then have notice.

Dated 22 May 2002

GULLACI & GULLACI, solicitors,  
158 Bell Street, Coburg, Victoria 3058.

---

Creditors, next-of-kin and others having claims in respect of the estate of MADELINA MARIA THOMAS, late of Unit 30, 8 Wellington Crescent, East Melbourne, Victoria, financial planner, who died on 26 December 2001, are required by the trustee, Jason David Thomas of Unit 3, 221 Errol Street, North Melbourne, Victoria 3051, doctor, to send particulars to him care of his undermentioned solicitors by 30 July 2002 after which date the trustee will convey or distribute the assets having regard only to the claims of which the executor has notice.

HOLDING REDLICH, solicitors,  
350 William Street, Melbourne 3000.

---

ERNEST GORDON MAYNE, late of 2 Gwalia Street, Traralgon, Victoria, retired gentleman, deceased. Creditors, next-of-kin and others having claims in respect of the estate of the abovenamed deceased, who died on 21 November 2001, are to send particulars of their claim to the executor, Donna Lee White, care of the undermentioned solicitors by 29 July 2002 after which date she will convey or distribute the assets having regard only to the claims of which she then has notice.

LITTLETON HACKFORD &  
D'ALESSANDRO PTY LTD, lawyers,  
94 Buckley Street, Morwell, Vic. 3840.

---

ANDREW JOHN WATSON, late of 4 Cameron Way, Pakenham, Victoria, electrical draftsman, deceased. Creditors, next-of-kin and others having claims in respect of the estate of the deceased, who died on 16 January 2002, are required by the executors, David Roderick Watson of 105 Chatsworth Road, Coorparoo, Queensland, Margaret Walton Watson of 26 Barnett Street, Hampton, Victoria and Michael James Lombard of 2 Milliara Grove, Brighton East, Victoria, to send particulars to them care of the undermentioned solicitors by 29 July 2002 after which date the executors may convey or distribute the assets having regard only to the claims of which they then have notice.

LUCAS LAWYERS, solicitors,  
8 Station Road, Cheltenham 3192.

---

IWAN ANDREJKO (also known as Ivan Andrejko and John Andrejko), late of Edenvale Nursing Home, East Keilor, Victoria, master painter, deceased. Creditors, next-of-kin and others having claims in respect of the estate of the deceased, who died on 20 December 2001, are required by the administrator, Equity Trustees Limited, ACN 004 031 298 of Level 2, 575 Bourke Street, Melbourne, Victoria, to send particulars to it by 31 July 2002 after which date it may convey or distribute the assets having regard only to the claims of which it has notice.

NICHOLAS O'DONOHUE & CO., lawyers,  
180 Queen Street, Melbourne 3000.

---

MICHAEL BACASH, late of 3 Berkeley Court, Kew, Victoria, retired, deceased. Creditors, next-of-kin and others having claims in respect of the estate of the abovenamed deceased, who died on 31 March 2002, are to send particulars of their claims to the executor, Annette Bacash-Armitage, care of the undermentioned solicitors by 5 August 2002 after which date the said executor will distribute the assets having regard only to the claims of which she then has notice.

O'BRIEN & GALANTE, solicitors,  
27 Norwood Crescent, Moonee Ponds.

---

Creditors, next-of-kin and others having claims in respect of the estate of LUCY SAPOUNAS, late of 21 St Hubert Road, East

Ivanhoe, in the State of Victoria, company director deceased, who died on 24 September 1999, are required to send particulars of such claims to the executor care of the undermentioned solicitors by 30 July 2002 after which date the executor will convey or distribute the assets having regard only to the claims of which the executor then has notice.

PIETRZAK SOLICITORS,  
222 La Trobe Street, Melbourne.

---

IAN EDGEWORTH McLEAN, late of 301 Aristotles Place, 114 Johnstone Street, Sunnyside, Pretoria, South Africa. Creditors, next-of-kin and others having claims in respect of the estate of the deceased, who died on 4 November 1999, are required by Perpetual Trustees Victoria Limited, ACN 004 027 258 of 360 Collins Street, Melbourne, Victoria, to send particulars of their claims to the said company by 30 July 2002 after which date it will convey or distribute the assets having regard only to the claims of which the company then has notice.

---

ARTHUR RAYMOND OWENS, late of Village Life Retirement Village, Unit 6, 7 Severin Court, Thurgoona, New South Wales, formerly of Unit 2, 522 Kiewa Place, Albury, New South Wales. Creditors, next-of-kin and others having claims in respect of the estate of the deceased, who died on 19 December 2001, are required by Perpetual Trustees Consolidated Limited, ACN 004 029 841 (in the will called National Mutual Trustees Limited) of 360 Collins Street, Melbourne, Victoria, to send particulars of their claims to the said company by 30 July 2002 after which date it may convey or distribute the assets having regard only to the claims of which the company then has notice.

---

KATHARINA ANNABELLA WEBER, late of Garoopna Uniting Care, 10 A'Beckett Street, Kew, Victoria, formerly of 4 Clifton Grove, East Hawthorn, Victoria. Creditors, next-of-kin and others having claims in respect of the estate of the deceased, who died on 6 January 2002, are required by Perpetual Trustees Limited, ACN 004 029 841 (in the will called National Mutual Trustees Limited) of 360 Collins Street, Melbourne, Victoria and Michael Peter Weber of 78 Macedon Road, Lower Templestowe, Victoria, to send particulars of their claims to the said company by 30 July 2002 after which date

it will convey or distribute the assets having regard only to the claims of which the company then has notice.

---

Creditors, next-of-kin or others having claims in respect of the estate of KENNETH CHARLES BAIN, late of Kilara Special Accommodation, Diamond Creek, Victoria, but formerly of 18 Hall Street, Flinders, Victoria, gentleman, deceased, who died on 22 April 2002, are to send particulars of their claims to the executor care of the undermentioned solicitors by 1 August 2002 after which date the executor will distribute the assets having regard only to the claims of which the executor then has notice.

RIGBY COOKE, solicitors,  
469 La Trobe Street, Melbourne 3000.

---

Re: AMY LOUISE PINK, late of 213 Dromana Parade, Safety Beach, home duties, deceased. Creditors, next-of-kin or others having claims in respect of the estate of the deceased, who died on 29 April 2002, are required by the trustees, Noel George Cameron of 213 Dromana Parade, Safety Beach, Victoria, retired and Meryl Louise Watson-Close, in the will called Meryl Louise Watson of 44 McNicol Terrace, Rosewater, South Australia, retired, to send particulars to the trustees by 31 July 2002 after which date the trustees may convey or distribute the assets, having regard only to the claims of which the trustees then have notice.

ROBERTS PARTNERS,  
216 Main Street, Mornington.

---

Re: TERESA HEWITT, late of Newcomb Nursing Home, Helms Street, Newcomb, deceased. Creditors, next-of-kin and others having claims in respect of the estate of the deceased, who died on 28 April 2002, are required by the deceased's personal representatives, Ann Therese Barfoot and Jeffrey Graeme Thornton, to send particulars to them care of the undermentioned solicitors by 29 July 2002 after which date the personal representatives may convey or distribute the assets having regard only to the claims of which they then have notice.

SEWELLS LARKINS & McCARTHY,  
lawyers,  
119 Murray Street, Colac.

---



Re: ANDREW GEORGE MASON, late of "Westlands" St. James, Victoria, farmer, deceased. Creditors, next-of-kin and others having claims in respect of the estate of the deceased, who died on 6 August 2000, are required by the trustees, Elizabeth Therese Mason of "Westlands", Tocumwal Road, St. James, Victoria, farmer and Roger Farquharson Mason of "Darebin Park", Merriang Road, Woodstock, Victoria, managing director, to send particulars of their claims to the trustees by 2 August 2002 after which date the trustees will convey or distribute the assets, having regard only to the claims of which the trustees then had notice.

WHITE CLELAND PTY., solicitors,  
3/454 Nepean Highway, Frankston 3199.

---

8116, Folio 674, upon which is erected a house known as 27 Westall Street, Thomastown.

Registered Mortgage No. U188696F affects the said estate and interest.

Terms – Cash/Eftpos  
(Debit Card only. No Credit Cards)

SW-02-001151-0

Dated 23 May 2002

S. BLOXIDGE  
Sheriff's Office

---

In the Supreme Court of the State of Victoria  
SALE BY THE SHERIFF

On Wednesday 26 June 2002 at 2.30 p.m. at the Sheriff's Office, 8-20 King Street, Oakleigh, (unless process be stayed or satisfied).

All the estate and interest (if any) of K. J. Stead Pty Ltd of 76 Anaconda Road, Narre Warren, proprietor of an estate in fee simple in the land described on Certificate of Title Volume 9883, Folio 121, which is vacant land known as Lot 24 Colorado Court, Hallam.

Registered Mortgage No. W789664W, Caveat No. X584630N and Covenant No. V301198F affect the said estate and interest.

Terms – Cash/Eftpos  
(Debit Card only. No Credit Cards)

SW-02-001195-0

Dated 23 May 2002

S. BLOXIDGE  
Sheriff's Office

---

In the Supreme Court of the State of Victoria  
SALE BY THE SHERIFF

On Wednesday 26 June 2002 at 2.30 p.m. at the Sheriff's Office, 8-20 King Street, Oakleigh, (unless process be stayed or satisfied).

All the estate and interest (if any) of Tuan Trong Lam (also known as Tuan Trung Lam) of 27 Westall Street, Thomastown, joint proprietor with Le Huong Ma of an estate in fee simple in the land described on Certificate of Title Volume

**Unclaimed Moneys Act 1962**

Register of Unclaimed Moneys held by the —

<i>Name of Owner on Books and Last Known Address</i>	<i>Total Amount Due to Owner</i>	<i>Description Of Unclaimed Money</i>	<i>Date when Amount first became Payable</i>
AMCOR LIMITED			
	\$		
Mr Albert Phillip Adams, 27 Taylor Crescent, Traralgon	167.01	Cheque	05/04/00
Mrs Jan Michele Alderson, 39 Albion Crescent, Greensborough	114.00	"	"
Ms Jennifer Catherine Allen, Unit 3, 19 Beechwood Road, Maleny, Qld	253.27	"	04/10/00
Estate Audrey L. Allnutt, 210 Drummond Street North, Ballarat	536.37	"	"
Estate Audrey L. Allnutt, 210 Drummond Street North, Ballarat	536.37	"	05/04/00
Altania Pty Limited, C/- Barry Mendel Frank & Co Services Pty Limited, Level 53, MLC Centre, Martin Place, Sydney, NSW	2,942.15	"	04/10/00
Mr Ronald Amputch, 7/164 Bellview Rd, Double Bay, NSW	100.70	"	05/04/00
Anatolia Investments Pty Ltd, 26 Elizabeth Street, Paddington, NSW	2,280.00	"	04/10/00
Mrs Margaret Wendy Anderson, Delamere, SA	505.02	"	"
Exors Late Kai Kok Ang, 116 Ragoon Road, Singapore	2,937.54	"	05/04/00
Mr George Annakis, 250 Gaffney Street, Pascoe Vale	274.74	"	"
Appleshaw Pty Limited, "The Hesse Family Account" 25 Broomfield Avenue, Fairfield	180.88	"	"
Doctor Anthony Arden & Doctor Felix Wilfrid Arden, "Anthony Arden Super Fund A/C", Alexandra, 201 Wickham Terrace, Brisbane, Qld	247.00	"	04/10/00
Mrs Muriel Una Armstrong, 101A Layfield Rd, Anstead, Qld	139.75	"	05/04/00
Estate Late Norman R. Arnott, C/- B. N. Arnott, 8 Lexham Square, Eltham	433.77	"	"
Mr Alan Richard Ashburner, 6 Tryon Ave, Wollstonecraft, NSW	414.77	"	04/10/00
Astyle Pty Limited, C/- Sir William Aston, 55 Olola Avenue, Vaucluse, NSW	258.21	"	"
Miss Elizabeth Mary Atkin, 4/43 East Crescent Street, McMahons Point, NSW	165.11	"	05/04/00
Miss Elizabeth Mary Atkin, 4/43 East Crescent Street, McMahons Point, NSW	165.11	"	04/10/00
Mr David James McAlpine Bainbridge & Mrs Judith Roslyn Bainbridge, 75 Brinsmead Lane, Leopold	199.88	"	05/04/00
Mr Emanuel Baldacchino, 137 The Strand, Gzira Gzr 03 Malta, Europe	167.70	"	"
M/S Jacqueline Marie Ballhausen, PO Box 126, Narromine, NSW	256.88	"	04/10/00
Mr Craig Douglas Balme, 8 Mons Street, Glen Iris	152.00	"	"
Mr Michael Anthony Baquie, 279 Lygon Street, Carlton	161.88	"	05/04/00
Mrs Stella Doreen Barnett, 23/61 Kooyong Road, Armadale	123.69	"	04/10/00

Mrs Stella Doreen Barnett, 23/61 Kooyong Road, Armadale Estate Late Doriel Rowena Bayles,	123.69	''	05/04/00
C/- Yuncken & Yuncken, 395 Collins Street, Melbourne	684.76	''	04/10/00
Mr Mario Bertolusso, 16 Laird Dve, Altona Green, Altona Meadows	209.00	''	05/04/00
Mr Angelo Biviano & Ms Sandra Bonomo, 159 Grandview Grove, Rosanna	161.88	''	''
Mrs Claire Rose Boymal, 1 Raynes Street, South Caulfield Estate Late Marjorie Joyce Brain, C/-Att Mrs R Jorgensen,	186.77	''	05/04/00
4 Willowbank Court, Templestowe	414.77	''	04/10/00
Mrs Rosemary Helen Brennan & Mr Simon Colin Poole Brennan, 2 Rosepark, Dundonald BT5 7RG, Northern Ireland	1,102.58	''	''
Mr Peter Robert Brent, 25 Parkwood Way, Traralgon	119.70	''	05/04/00
Mrs Melissa Clare Brice, 48 Dunrossil Ave, Carlingford, NSW	190.00	''	04/10/00
Mrs Raelene Broadway, C/- PO Box 3, Glen Waverley	201.40	''	05/04/00
Brodekin International Inc., PO Box 279, Beaconsfield, NSW	1,003.39	''	''
Brodekin International Inc., PO Box 279, Beaconsfield, NSW	1,003.39	''	04/10/00
Ms Kristine Clare Brook, 9 Cleveley Avenue, Kings Langley, NSW	151.62	''	04/10/00
Mr Martin Brown, 2/41 Albert Avenue, Boronia	170.42	''	''
Mrs Nancy M. Brown, C/- David W. Lee & Associates, GPO Box 4610, Sydney, NSW	437.00	''	05/04/00
Mr Roger W. Brown, PO Box 5, Lyneham, ACT	537.54	''	04/10/00
Mr Roger W. Brown, PO Box 5, Lyneham, ACT	480.79	''	05/04/00
Bryman Pty Ltd, "Plunkett/Lyons S/Fund A/C", 18 Derby Street, Camberwell	114.00	''	04/10/00
Mr Kenneth M. Burley, 73 Mons Avenue, Maroubra, NSW	101.37	''	05/04/00
Mr Kenneth M. Burley, 73 Mons Avenue, Maroubra, NSW	113.02	''	04/10/00
Estate Late Alfred Victor Bushell, C/- Michael Baumann, PO Box 1717, Fyshwick, ACT	513.00	''	05/04/00
Estate Late Alfred Victor Bushell, C/- Michael Baumann, PO Box 1717, Fyshwick, ACT	513.00	''	04/10/00
Butali Pty Limited, C/- Mr Michael Inglis, Level 11, Garfield Barwick Chambers, 53 Martin Place, Sydney, NSW	159.21	''	05/04/00
Butali Pty Limited, C/- Mr Michael Inglis, Level 11, Garfield Barwick Chambers, 53 Martin Place, Sydney, NSW	178.16	''	04/10/00
Mr Peter M. Butler, 8 Canterbury Road, Toorak	163.21	''	05/04/00
Mrs Mary Byrne, 115 McNamara Street, Airport West	142.50	''	''
Mrs Mary Byrne, 115 McNamara Street, Airport West	142.50	''	04/10/00
Father Paul William Byrne, 17 Bellhurst Outlook, Tarragindi, Qld	127.11	''	''
Mrs Noel Inga Cahill, 16 Blessington Street, St Kilda Cairnsmore Pty Ltd, "DS Forbes Pension Fund A/C", Seven Oaks, 585 Moss Vale Road, Burradoo, NSW	307.98	''	05/04/00
Cairnsmore Pty Ltd, "DS Forbes Pension Fund A/C", Seven Oaks, 585 Moss Vale Road, Burradoo, NSW	266.00	''	''
Mr Russell Ronald Caplan, C/- Equilon Enterprises Llc, 12700 Northborough Drive, Houston, Texas 77067 USA	266.00	''	04/10/00
Mr Garry Richard Caple, 17 Dion Place, Coolbellup, WA	259.49	''	05/04/00
Mr Garry Richard Caple, 17 Dion Place, Coolbellup, WA	199.12	''	04/10/00
Mr Garry Richard Caple, 17 Dion Place, Coolbellup, WA	199.12	''	05/04/00
Carpland Pty Ltd, 14 Victoria Street, Brighton	148.77	''	''

Mr David J. Cashman, Lot 106, Billabirra Crescent, Nerang, Qld	110.96	”	04/10/00
Mr David J. Cashman, Lot 106, Billabirra Crescent, Nerang, Qld	110.96	”	05/04/00
C D Browne Pty Limited, “Superannuation Fund A/C”, 6 Dalmeny Road, Northbridge, NSW	190.00	”	04/10/00
C D Browne Pty Limited, “Superannuation Fund A/C”, 6 Dalmeny Road, Northbridge, NSW	190.00	”	05/04/00
Chambers Music Pty Limited, “Superannuation Fund A/C”, C/- G. War, PO Box 477, St Leonards, NSW	127.11	”	”
Ms Annette Sil Maing Cheung, Unit 9, 1 Kings Bay Avenue, Five Dock, NSW	304.00	”	”
Christahl Pty Ltd, PO Box 133, Burnley	256.88	”	04/10/00
Christahl Pty Ltd, PO Box 133, Burnley	256.88	”	05/04/00
Mrs Airlie R. Circuit, “Ulonga”, Hay, NSW	294.45	”	”
Mr Peter William Clarke & Mr Matthew Leonard Perry, “Essex Super Fund A/C”, 60 Steeles Creek Rd, Yarra Glen	112.10	”	04/10/00
Mrs Manda Elizabeth Cole, PO Box 212, Caulfield South	876.66	”	05/04/00
Consolidated Ventures Inc., PO Box 1451, Port Vila, Vanuatu	764.75	”	04/10/00
Mr Con Constantinou, “Con Constantinou S/F A/C”, 7 The Crescent, Port Melbourne	161.31	”	”
Mr Con Constantinou, “Con Constantinou S/F A/C”, 7 The Crescent, Port Melbourne	161.31	”	05/04/00
Mr Andrew William Cook, RMB 83, Nhill	207.48	”	”
Ms Elizabeth Cook, 1A Chilcote Avenue, Malvern	1,157.48	”	04/10/00
Mr Darryl Mervyn Cooke, PO Box 201, Virginia, Qld	161.88	”	05/04/00
Mrs Judith Blanche Cooke, 19 Norman Street, Wembley Downs WA	285.38	”	04/10/00
Miss Wilma M. Courthope, GPO Box 1220M, Hobart, Tas.	424.27	”	”
Miss Wilma M. Courthope, GPO Box 1220M, Hobart, Tas.	424.27	”	05/04/00
Mr Norman Clive Coventry, RMB 1412, Benalla	166.67	”	04/10/00
M/s Frances Elizabeth Craig, 39 Laurel Bank Parade, Newtown	123.31	”	05/04/00
Mrs Jeanette Lesleigh Craig, 182 Queens Road, Everton Hills, Qld	119.70	”	04/10/00
M/s Josephine Anne Crawford, “Windouran” Moulamein, NSW	319.77	”	”
Cresswell Nominees Pty Ltd, Attn Chris Chriscoll, Penthouse Hotel, Cnr Barry Road and Maffra St, Coolaroo	294.88	”	”
Crittenden Management Pty Ltd, “Crittenden Super Fund A/C”, 27 Pakington Street, Geelong West	194.37	”	”
Crittenden Management Pty Ltd, “Crittenden Super Fund A/C”, 27 Pakington Street, Geelong West	194.37	”	05/04/00
Mr Henry E. M. Crofton, C/- Standard Bank of South Africa, Adderley Street, Cape Town, South Africa	342.09	”	04/10/00
Mr Henry E. M. Crofton, C/- Standard Bank of South Africa, Adderley Street, Cape Town, South Africa	288.08	”	05/04/00
Dr Mark Laurence Cunningham, C/- Mutual Trust Pty Ltd, PO Box 12, Collins Street, Melbourne	765.13	”	”

Mrs Joan Ilma Curtis, Lisson Manor, 12 Lisson Grove, Hawthorn	475.00	''	''
M/s Margaret Haighton Davidson & Mr Francis Peter Newman C/- Thynne & Macartney, GPO Box 245, Brisbane, Qld	1,427.28	''	04/10/00
Ms Kate Davies, 603 Tower B, Queens Garden, 9 Old Peak Road, Mid Levels, Hong Kong	228.00	''	''
Mr John Ernest Davis & Mrs Jan Marie Davis, "Stockwell Lodge Ex S/F A/C", 14 Tennyson Street, Brighton	144.40	''	''
Mr John Ernest Davis & Mrs Jan Marie Davis, "Stockwell Lodge Ex S/F A/C", 14 Tennyson Street, Brighton	144.40	''	05/04/00
Mrs Judith Suzanne Day, 50 Riddle Drive, Melton	130.35	''	04/10/00
Mr Darrel Dealtry, "Dealtry Super Fund A/C", C/- R A Laurenson, PO Box 258, Subiaco, WA	190.00	''	05/04/00
Mr John Delohery, 9/5 Sutherland Street, Cremorne, NSW	247.95	''	''
Mr John M. Devine, 313 Burraneer Bay Rd, Caringbah, NSW	221.35	''	04/10/00
Devlin Bros Pty Ltd, "Superannuation Fund A/C", 20-22 Lambert Avenue, Newtown	602.11	''	''
Devlin Bros Pty Ltd, "Superannuation Fund A/C", 20-22 Lambert Avenue, Newtown	602.11	''	05/04/00
Mr Sam Dilorenzo, 9 Lang Street, Clifton Hill	186.77	''	''
Mr John Dimopoulos, 32 Evelyn Street, Clayton Dingla Pty Limited, "Dingla Super Benefit A/C", PO Box 823, Neutral Bay, NSW	180.50	''	04/10/00
Mrs Elizabeth Emily Dingle, 22 Rees Ave, Clayfield, Qld	133.00	''	''
Mrs Elizabeth Emily Dingle, 22 Rees Ave, Clayfield, Qld	104.88	''	05/04/00
Mr Bevan John Dix, 77 McMahon Road, Reservoir	100.70	''	04/10/00
Mr Bevan John Dix, 77 McMahon Road, Reservoir	100.70	''	05/04/00
Mr Timothy John Doherty, "Est Burnard Doherty A/C", PO Box 126, East Kew	130.35	''	04/10/00
Mr Timothy John Doherty, "Est Burnard Doherty A/C", PO Box 126, East Kew	116.30	''	05/04/00
Mr Steven Kenneth Drummy, 70 Wales Street, Thornbury	114.00	''	04/10/00
Mrs Sheila Eddy, 9 Bradman Street, Boronia	228.00	''	''
Mr Peter L. Ellison, 27 Kennaway Street, Tusmore, SA	249.47	''	''
Mr Rodney David Elvish, 12 Hudson Close, Turrumurra, NSW	416.35	''	05/04/00
Mr Athol Maxwell Everett, RMB B799, Ballarat	608.00	''	04/10/00
Mrs Joan E. Evershed, 2 Chapman Street, Bellerive, Tas.	241.68	''	''
Mr Terry Ewing, PO Box 39, Sandy Bay, Tas.	130.35	''	''
Mr Terry Ewing, PO Box 39, Sandy Bay, Tas.	116.30	''	05/04/00
Mr Stephen Fafrak, 63 Stockdale Road, Traralgon	208.81	''	04/10/00
Mrs Hilma M. Ferguson, 21 Nairana Rest, Noosa Heads, Qld	209.00	''	''
Mrs Marjorie J. Fidler, Wyatt Crescent, Burnie, Tas.	132.13	''	''
Mrs Janice Mearthur Field 35 West Road Pearce Dale Fileyard Pty Limited, C/- WHTM Asset Management Ltd, GPO Box 385, Brisbane, Qld	337.44	''	05/04/00
Findon Lane Pty Ltd, 117 Mitchell Street, Northcote	130.35	''	04/10/00
Estate Late Beryl R. Fitzgerald, 19 Walpole Ave, Belmont	347.70	''	''
Mrs Bettina Yuen Seng Fong, C/- Computershare Registry Services Pty Ltd, GPO Box 2848EE, Melbourne	532.00	''	05/04/00
	111.15	''	04/10/00

Mrs Bettina Yuen Seng Fong, C/- Computershare Registry Services Pty Ltd, GPO Box 2848EE, Melbourne	111.15	''	05/04/00
Tong Chin-Foong, 26 Jalan Tenang, Singapore 277960 Rep of Singapore	183.92	''	''
Mr Robert B. Ford, 17 Reservoir Street, Chidlow WA Fourth Nargun Pty Ltd, "Grant Family No 2 A/C", 10 Bent Street, Brighton	109.46	''	04/10/00
Mrs Jean A. Freeth, 50 Broadbeach Boulevard, Hillarys, WA Freight On Board Pty Limited, "A/C Super Fund", C/- Peter Cair, 9th Floor, 100 Christie Street, St Leonards, NSW	112.67	''	''
Ms Jane Helen Fry, 28 Peregrine Drive, Kinglake West	339.72	''	''
Ms Susan L. Fry, 18 Landale Avenue, Mount Clear	317.11	''	05/04/00
Mrs Pamela M. Furhagen, C/- Bank of NSW, 9-15 Sackville Street, London W1 England	145.35	''	''
Mrs Pamela M. Furhagen, C/- Bank of NSW, 9-15 Sackville Street, London W1 England	160.92	''	''
Mr Ralph Garbers, "Garbers Super Fund A/C", 26 Genista Street, Frankston	132.21	''	04/10/00
Mr Ralph Garbers, "Garbers Super Fund A/C", 26 Genista Street, Frankston	128.91	''	05/04/00
M/s Wilma Rosalie Garnett, 56 Arabella Street, Longueville, NSW	190.00	''	04/10/00
M/s Wilma Rosalie Garnett, 56 Arabella Street, Longueville, NSW	190.00	''	05/04/00
Mr John Gartside, 22 Ben Hogan Crescent, Parkwood, Qld	224.77	''	''
Mr Giovanni Gaudio & Mrs Bale Gaudio, 49 Allsops Road, Launching Place	224.77	''	04/10/00
Prof Robert Goulston Gilbert, Chemistry School, University of Sydney, Sydney, NSW	152.00	''	''
Prof Robert Goulston Gilbert, Chemistry School, University of Sydney, Sydney, NSW	256.88	''	''
Mr Robert William Gillott, 11 Maryvale Road, Morwell	1,615.00	''	''
G L McCardle Nominees Pty Ltd, "McCardle Executive Unit A/C", 71 Royal Avenue, Sandringham	408.12	''	05/04/00
G L McCardle Nominees Pty Ltd, "McCardle Executive Unit A/C", 71 Royal Avenue, Sandringham	205.20	''	04/10/00
Mr Aaron Gold, C/- J. J. Loader, Potter Warburg Securities Ltd, GPO Box 4151, Sydney, NSW	205.20	''	04/10/00
Mr Aaron Gold, C/- J. J. Loader, Potter Warburg Securities Ltd, GPO Box 4151, Sydney, NSW	130.35	''	''
Mr Ahmet Golec, 47/72 Derby Street, Kensington	116.30	''	05/04/00
Mr Ahmet Golec, 47/72 Derby Street, Kensington	119.70	''	04/10/00
Mr Leonard Francis Gouge, 175 West Street, Glenroy	119.70	''	05/04/00
Mr Michael A. Graham, 35 Westburn Terrace, Christchurch, New Zealand	304.00	''	04/10/00
Mr Michael Hugo Gramp, 53 Langmeil Road, Tanunda, SA	210.17	''	05/04/00
Mr Simon John Green, 3 Money Street, Perth, WA	175.94	''	''
	190.00	''	''

Mrs Beryl Joy Greenwood, 81 Old Gippsland Rd, Lilydale	142.88	''	''
Mr James Carnegie Grimwade & Mr Anthony David Grimwade, "A/C J C Grimwade Pty Ltd Super Fund", 15 Stonnington Place, Toorak	222.11	''	''
Mr Peter N. Grimwade & Mr Robert N. Grimwade, C/- G I Stevenson & Co, 5th Floor, Temple Court, 422 Collins Street, Melbourne	193.99	''	04/10/00
Mr Peter N. Grimwade & Mr Robert N. Grimwade, C/- G I Stevenson & Co, 5th Floor, Temple Court, 422 Collins Street, Melbourne	193.99	''	05/04/00
Mr Martin Greville Grogan & Mrs Helen Margaret Grogan, 1 Balaka Avenue, Aspendale	114.00	''	04/10/00
Mr Martin Greville Grogan & Mrs Helen Margaret Grogan, 1 Balaka Avenue, Aspendale	114.00	''	05/04/00
Mr Dennis W. Groves, 52 Campsie Street, Campsie, NSW	100.70	''	''
Gullawar Grove Pty Ltd, C/- Superannuation Fund, Korrine Road, Glen Alvie	154.09	''	04/10/00
Gullawar Grove Pty Ltd, C/- Superannuation Fund, Korrine Road, Glen Alvie	154.09	''	05/04/00
Mr Colin J. Guppy, 94 Brighton Street, Petersham, NSW	100.70	''	04/10/00
Mr Colin J. Guppy, 94 Brighton Street, Petersham, NSW	100.70	''	05/04/00
Miss Gwenda E. Haley, C/- L. J. Collins Molomby & Molomby, 575 Bourke Street, Melbourne	142.50	''	04/10/00
Mr Rodney Turner Halstead, "Halstead Super Fund A/C", 83 Balfour Road, Rose Bay, NSW	194.41	''	05/04/00
Mr Keith Jackson Hancock, 6 Maturin Road, Glenelg, SA	344.09	''	''
Dr Peter Haron & Dr Bronwyn Haron, 44 Atopia Court, Tallai, Qld	532.00	''	04/10/00
Mrs Esther L. Hartnett, 47 Twigg St, North Rockhampton, Qld	209.00	''	05/04/00
Mrs Esther L. Hartnett, 47 Twigg St, North Rockhampton, Qld	209.00	''	04/10/00
Lady Gladys Winifred Hartnett, PO Box 49, Clayton	315.55	''	05/04/00
Lady Gladys Winifred Hartnett, PO Box 49, Clayton	352.90	''	04/10/00
Mr Harry Hasiotis, 29 Willowbank Road, North Fitzroy	197.22	''	''
Mrs Janet Hatton, 1010 Merriang Road, Woodstock	259.92	''	''
Mr Stuart James Hayward & Mrs Kathleen Miriam Hayward, PO Box 299, Wyong, NSW	114.00	''	''
Mr Stuart James Hayward & Mrs Kathleen Miriam Hayward, PO Box 299, Wyong, NSW	114.00	''	05/04/00
Mr George S. Heales, 3 Eva Court, Fawkner	114.95	''	04/10/00
Miss Margaret M. Healy, Flat 10, 9 Sydney Street, Prahran	747.08	''	''
Miss Margaret M. Healy, Flat 10, 9 Sydney Street, Prahran	747.08	''	05/04/00
Mr Ian Alan Hewitt, C/- Lester Fielden & Faraone, 14 Havehton Road, Oakleigh	436.46	''	04/10/00
Mr Charles W. G. Heydon, 180 Broome St, Cottesloe, WA	399.00	''	''
Mr William P. Hiatt, 4 Shaw Avenue, Kingsford, NSW	185.97	''	''
Mr William P. Hiatt, 4 Shaw Avenue, Kingsford, NSW	166.07	''	05/04/00
Mr Michael Justin Hibbins, 221 Burke Road, Glen Iris	260.20	''	04/10/00
Mr Michael Justin Hibbins, 221 Burke Road, Glen Iris	232.55	''	05/04/00
M/s Helen Mary Hill, 14 Westgarth Stree, Fitzroy	135.47	''	''

Mr Normand Frank Hinde, 135/260 Military Road, Neutral Bay NSW	490.77	”	04/10/00
Dr Steven Hoefflin, 1530 Arizona Avenue, Santa Monica California, United States of America	171.47	”	”
Dr Steven Hoefflin, 1530 Arizona Avenue, Santa Monica California, United States of America	167.20	”	05/04/00
Dr Ursula Hoff, 678 Canning Stree, North Carlton	400.52	”	04/10/00
Mr Clive Roy Hoffmann & Mr Philip James Hoffmann, C/- Ms Cheryl Viner, 3 Gordon Street, Glenelg, SA	190.00	”	05/04/00
Mrs Enid Deloitte Hogan, 60 Meiers Rd, Indooroopilly, Qld	380.00	”	04/10/00
Mrs Sophie Audrey Elizabeth Holloway, Suite 123, 45 Glenferrie Road, Malvern	1,029.80	”	05/04/00
Mr Kai Hong Hon, 4/116 Sir Fred Schonell Drive, St Lucia, Qld	130.35	”	04/10/00
Ms Heather Joy Hooper, 18 Mowbray Street, Hawthorn East	686.24	”	”
M/s Magda Horvat, Unit 6, 316 Wattletree Rd, Malvern East	541.88	”	”
Mr Geoffrey F. Hosking, 10 Lorikeet Street, Bundaberg, Qld	490.20	”	”
Mr Phillip R. Hynard, 17 Old Dayboro Road, Petrie, Qld	271.70	”	05/04/00
Mr John B. Ingram, 9 Talmiro Street, Whalan, NSW	119.70	”	04/10/00
Mr John B. Ingram, 9 Talmiro Street, Whalan, NSW	119.70	”	05/04/00
Mr Graeme T. Inkster, 16/7 Garden Street, Telopea, NSW	143.50	”	04/10/00
Mr Graeme T. Inkster, 16/7 Garden Street, Telopea, NSW	128.00	”	05/04/00
Iron dove Pty Limited, 3/147 Darling Point Road, Darling Point, NSW	256.88	”	”
Mr David Irvine & Mrs Adrienne Irvine, 7 Cornish Place, Aspley, Qld	104.45	”	04/10/00
Miss Hilary B. Irwin, 9 O’Shaughnessy Street, Kew,	1,333.23	”	”
Miss Hilary B. Irwin, 9 O’Shaughnessy Street, Kew,	1,333.23	”	05/04/00
Mrs Jean H. Ison, PO Box 449, Lismore, NSW	143.45	”	04/10/00
Mr Rodney H. Ison, PO Box 449, Lismore, NSW	147.06	”	”
Mr Rodney H. Ison & Mrs Jean H. Ison, PO Box 449, Lismore, NSW	106.78	”	”
J Bini Investments Pty Ltd, “Super Fund A/C”, 23 Hillcrest Road, Emu Heights, NSW	195.25	”	”
J Bini Investments Pty Ltd, “Super Fund A/C”, 23 Hillcrest Road, Emu Heights, NSW	174.40	”	05/04/00
Mrs Lily Jack, 33 Parker Street, Pascoe Vale	104.07	”	04/10/00
Ms Creina Mary Jarrett, 41B Glenunga Ave, Glenunga, SA	172.33	”	”
Mrs Ronda Anne Jenkins, PO Box 800, Murwillumbah, NSW	190.00	”	”
Joined Up Thinking Pty Ltd, “Blampied A/C”, 34 Billyard Avenue, Elizabeth Bay, NSW	190.00	”	”
Joined Up Thinking Pty Ltd, “Blampied A/C”, 34 Billyard Avenue, Elizabeth Bay, NSW	190.00	”	05/04/00
Jolly Anne Equipment Pty Ltd, “A/C Jolley Family Trust”, 204 Stumpy Gully Road, Moorooduc	201.21	”	”
Mr Keith Jopp, “Jepson Family No 2 A/C”, 18 Victoria Street, Brighton	224.77	”	04/10/00
Exors Late Bertha M Jordan, C/- Pascoe Whittle, GPO Box 4465, Sydney, NSW	244.72	”	”
Exors Late Bertha M Jordan, C/- Pascoe Whittle, GPO Box 4465, Sydney, NSW	244.72	”	05/04/00
Mr Romil Joukoff, 9 Thomas Avenue, Moorabbin	141.93	”	04/10/00



Mr Edmund A. D. Jowett, Clonbinane Park, Broadford	288.80	''	''
Mr Todd Dylan Joyce, 11 Hales Street, Riverview, Qld	114.00	''	''
Mrs Margaret Helen Kaethner, 93 Crouch Street South, Mt Gambier, SA	428.83	''	05/04/00
Mrs Susan Jean Keable, PO Box 544, Lilydale	256.88	''	04/10/00
Kearney & Tyrrell Pty Ltd, 53 Rose Street, Essendon Kearns Family Holdings Pty Ltd, "A/C W P Kearns Super Fund", Jack Shand Chambers Level 55, MLC Centre, 19-29 Martin Place, Sydney, NSW	285.00	''	05/04/00
Kearns Family Holdings Pty Ltd, "A/C W P Kearns Super Fund", Jack Shand Chambers Level 55, MLC Centre, 19-29 Martin Place, Sydney, NSW	256.88	''	''
Miss Shannon Louise Kelly, C/- Mrs R Morgan, 21-23 Horbury Street, Sans Souci, NSW	133.00	''	''
Ms Alison Kennedy, 353 Richardson Street, Middle Park	256.88	''	''
Mr Graeme Kirk, 32 Zouch Road, Denham Court, NSW Kitt Pty Ltd, "Kane Construct Exec SF A/C", 28-34 Rooney Street, Richmond	259.16	''	05/04/00
Kitt Pty Ltd, "Kane Construct Exec SF A/C", 28-34 Rooney Street, Richmond	798.00	''	04/10/00
Kitzmill Pty Ltd, 17 Myrtle Road, Hampton	798.00	''	05/04/00
Mrs Alison Bertha Knudsen, Chesalon Nursing Home, 25 Trelawney Street, Eastwood, NSW	551.00	''	04/10/00
Korrian Pty Ltd, "CM Thompson Super Fund A/C", C/- Australis Circuit, Port Melbourne	718.39	''	''
Korrian Pty Ltd, "CM Thompson Super Fund A/C", C/- Australis Circuit, Port Melbourne	283.63	''	''
Ms Helen Koustas, 6 Bendigo Avenue, Elwood	253.58	''	05/04/00
Mrs Lorna Mary Kurrle, PO Box 53, Kenthurst, NSW	129.77	''	''
Mr Martin Lajtman, 6 Occord Crt, St Albans	343.14	''	04/10/00
Mr Kleanthis Lambrakakis, 39 Laurie Street, Newport	100.70	''	''
Mr Raymond Steven Lanham, 26 Ross Street, Chipping Norton, NSW	132.24	''	05/04/00
Mrs Merle Larche, 39 Barremma Road, Lakemba NSW	247.19	''	04/10/00
Mr Charles Lay, 10/314 Bondi Road, Bondi NSW	209.00	''	''
Mr Charles Lay, 10/314 Bondi Road, Bondi NSW	203.11	''	05/04/00
Mr Peter A. Legros, 4 Beethoven Place, Cranebrook, NSW	203.11	''	04/10/00
Mr Peter A. Legros, 4 Beethoven Place, Cranebrook, NSW	100.70	''	05/04/00
Mr Michael Lewis, 13-14 McDonald Court, Narre Warren	100.70	''	04/10/00
Mr Michael Lewis, 13-14 McDonald Court, Narre Warren	112.10	''	05/04/00
Mrs Mey M. Lim, 47 Jalan SS22A/1 Damansara Jaya, Petaling Jaya 47400 Selangor, Malaysia	112.10	''	04/10/00
Mrs Mey M. Lim, 47 Jalan SS22A/1 Damansara Jaya, Petaling Jaya 47400 Selangor, Malaysia	178.74	''	05/04/00
Ms Jennifer Margaret Line, 101 Otago Bay Road, Otago Bay, Tas.	183.31	''	04/10/00
Mr Anthony John Liston. "Liston Family Superfund A/C", Glenrock, Berridale, NSW	190.00	''	05/04/00
Mr Anthony John Liston. "Liston Family Superfund A/C", Glenrock, Berridale, NSW	190.00	''	''
Mrs Betty Lohrera & Mr David Lohrera, "David A. Lohrere Account" C/- Middletons Moore Bevins, Level 29/200 Queen Street Melbourne	190.00	''	04/10/00
Miss Catherine Banfield Rivett Long, 52 Perry St, Fairfield	332.08	''	''
	255.36	''	05/04/00

Miss Catherine Banfield Rivett Long, 52 Perry St, Fairfield	255.36	''	04/10/00
Long Nose Investments Pty Ltd, C/- Allen Allen & Hemsley, Level 17, Chifley Tower, 2 Chifley Square Sydney, NSW	104.45	''	''
Estate Late Dorothy Ada Lonie & Mrs Gillian Maisie King & Mr Ian Hay McGregor Lonie, C/- Deloitte PBS, GPO Box 78B, Melbourne	531.05	''	''
Loscons, 18 Pty Ltd, C/- Ken Carver, 43 Gordon Street, Clontarf, NSW	1,140.00	''	05/04/00
Loumarkham Pty Ltd, "Lorne Hotel S/Fund A/C", C/- Davidsons-De&M, 351 Moorabool Street, Geelong	186.77	''	''
Dr Jack W. Lowe, "Riverview", Reids Flat, NSW	232.94	''	04/10/00
Dr Jack W. Lowe, "Riverview", Reids Flat, NSW	232.94	''	05/04/00
Mr Keith Lund & Mrs Phyllis Nita Lund, 16 Northminster Way, Rathmines, NSW	484.50	''	''
Dr Patrick Francis Lyons, "Pat Lyons Personal Sup A/C", 59 Augusta Road, Lenah Valley, Tas.	239.50	''	04/10/00
Dr Patrick Francis Lyons, "Pat Lyons Personal Sup A/C", 59 Augusta Road, Lenah Valley, Tas.	214.30	''	05/04/00
M & S Custodians Pty Ltd, "Auld & Sons Pty Ltd S/F A/C", PO Box 321, Kyabram	256.88	''	''
M & S Custodians Pty Ltd, "Auld & Sons Pty Ltd S/F A/C", PO Box 321, Kyabram	256.88	''	04/10/00
Mr Colin W. MacDonald, Unit 304, 127 Beach Street, Port Melbourne	397.29	''	''
Mr David Andrew MacLean, 1 Park Street, Mordialloc	119.32	''	05/04/00
Mr David Andrew MacLean, 1 Park Street, Mordialloc	119.32	''	04/10/00
Malat Pty Ltd, "A & J Millar Super A/C", 245 New Line Road, Dural, NSW	129.77	''	05/04/00
Estate Late Hermine Mandl & Mrs Sylvia B. Mandl, 25 Lynwood Avenue, Mt Albert, Auckland, New Zealand	144.80	''	''
Marlding Pty Limited, "Charles Keith Gay Family A/C", 11 Fennell Street, North Parramatta, NSW	101.46	''	''
Marlding Pty Limited, "Charles Keith Gay Family A/C", 11 Fennell Street, North Parramatta, NSW	101.46	''	04/10/00
Marson Pty Limited, C/- Ken Carver, 43 Gordon Street, Clontarf, NSW	2,470.00	''	05/04/00
Mr Ian Martinac, 10 Rathdonnell Street, Auchenflower, Qld	131.10	''	04/10/00
Mr Ian Martinac, 10 Rathdonnell Street, Auchenflower, Qld	131.10	''	05/04/00
Miss Yayoi Matsubara, Unit 6, 15-27 Ogami, Ayase+Shi Kanagawa-Ken 252 110 Japan	171.47	''	04/10/00
Miss Aline Scott-Maxwell, 75 Davies Street, Brunswick	161.88	''	05/04/00
Miss Aline Scott-Maxwell, 75 Davies Street, Brunswick	161.88	''	04/10/00
Mr Anthony John McCauley, 154 Bettington Road, Dundas, NSW	798.00	''	''
Mr Alexander McColgan, 40 Homestead Way, Sunbury	272.46	''	''
Mr Alexander McColgan, "McColgan Super Fund A/C", 40 Homestead Way, Sunbury	380.00	''	''
Mrs Catherine Mary McColgan, 40 Homestead Way, Sunbury	272.46	''	''
Dr Heather McCrae, 298 York Street, Launceston, Tas.	166.44	''	05/04/00
Dr Heather McCrae, 298 York Street, Launceston, Tas.	166.44	''	04/10/00
Sabihe Manouchere McDonald, 7 Park Court, Springwood, Qld	6,798.58	''	05/04/00
Mr John William McIntyre, 2 Diosma St, Toowoomba, Qld	224.77	''	04/10/00

<i>Victoria Government Gazette</i>	<i>G 22</i>	<i>30 May 2002</i>	<i>1083</i>
Mr John William McIntyre, 2 Diosma St, Toowoomba, Qld	224.77	”	05/04/00
Mr Angus Campbell McKechnie, 15/449 St Kilda Road, Melbourne	1,020.30	”	”
Mr Angus Campbell McKechnie, 15/449 St Kilda Road, Melbourne	1,020.30	”	04/10/00
Ms Edith Pryor McKenzie & Ms Fay Calder Donlevy, “Estate G. G. C. McKenzie A/C”, Aitken Walker & Strachan, GPO Box 5453CC, Melbourne	224.77	”	”
Mrs Edna Kate McKenzie, C/- Robinson Beale & Horton, PO Box 1836, North Sydney, NSW	130.35	”	”
Mr George Comyn McKenzie & Mrs Alison Mary McKenzie, “Tartan Super Fund A/C”, 10th Floor, 81 Flinders Street, Adelaide, SA	190.00	”	”
Mr George Comyn McKenzie & Mrs Alison Mary McKenzie, “Tartan Super Fund A/C”, 10th Floor, 81 Flinders Street, Adelaide, SA	190.00	”	05/04/00
Robert L. McMahan Jnr, 55 Ryder Street, Niddrie	350.93	”	”
Mrs Amanda McMullen, 108 Carrington Road, Randwick, NSW	347.89	”	04/10/00
Mr Michael McNamara, 13/148 Spit Rd, Mosman, NSW	230.09	”	”
Mrs Janifer Mary Melin, 1/11 Tattenham Street, Carnegie	118.75	”	05/04/00
Michael Daniels & Company Pty Ltd, 50 Queen Street, Warragul	129.77	”	04/10/00
Michael Hodgett Pty Ltd, “Michael Hodgett S/Fund A/C” PO Box 1099, Mudgee, NSW	342.38	”	”
Mr Reginald F. Michell, Unit 11, 38 Stanton Road, Mosman, NSW	218.88	”	”
Miss Olive Jean Micheltore, C/- Estate Admin Services, PO Box 6099, Halifax Street, Adelaide, SA	302.10	”	05/04/00
Micla Enterprises Pty Ltd, 1 Blue Water Court, Balnarring	127.30	”	04/10/00
Mikata Holdings Pty Ltd, 7/16 National Circuit, Barton, ACT	564.30	”	”
Mrs Ethel Milbank, PO Box 139, Meadows, SA	102.70	”	05/04/00
Mr Eric Edward Milkins, 53 Viewhill Crescent, Eltham	461.13	”	04/10/00
Miss Katharine Margaret Millear, “Yooranalee”, Willaura	141.72	”	”
Miss Katharine Margaret Millear, “Yooranalee”, Willaura	126.67	”	05/04/00
Mr Roy Colin Millen, 135 Mountjoy Terrace, Manly, Qld	167.58	”	04/10/00
Ms Joanna Dorothy Miller, 76 Rossmoyne Street, Thornbury	100.13	”	”
Estate Late William Millwood, C/- Eric Butler, PO Box 912, Charlestown, NSW	323.00	”	05/04/00
Mishamondo Pty Ltd, “Roma Superannuation Fund A/C”, PO Box 55, Sans Souci, NSW	332.50	”	04/10/00
M O Holdings Pty Ltd, “M O Family Account”, PO Box 1326, Wodonga	190.00	”	”
Ms Jeanene Montanbault, 1419 Fielding Street, Ferndale, Michigan 48220, USA	246.41	”	”
Ms Jeanene Montanbault, 1419 Fielding Street, Ferndale, Michigan 48220, USA	240.27	”	05/04/00
Moravian Pty Ltd, PO Box 574, Kenmore, Qld	190.00	”	05/04/00
Mr Roger Morelli (Jnr), GPO Box 1471, Canberra, ACT	348.85	”	”
Estate Late Elizabeth M. Morrow, C/- Packer & Austin, PO Box 51, Fivedock, NSW	288.42	”	04/10/00
Mrs Susette Patricia Moylan, PO Box 1102, Nedlands, WA	273.40	”	”
M S Downey Pty Ltd, PO Box 35, Aldinga Beach, SA	132.58	”	”

M S Downey Pty Ltd, PO Box 35, Aldinga Beach, SA	118.53	''	05/04/00
Ms Deborah Ellen Mulcair, 3 Gardenia St, Cronulla, NSW	273.73	''	''
M/s Angelica Elizabeth Murphy, 7/501 Miller Street, Cammeray, NSW	209.00	''	''
M/s Angelica Elizabeth Murphy, 7/501 Miller Street, Cammeray, NSW	209.00	''	04/10/00
Mr Uriy Nechtcherov, Unit 24, 7 Bolshaya Street, Khabarovsk 68009, Russian Federation	275.31	''	''
Neeloc Pty Ltd, C/- Norman Hardy, 12th Floor, 68 Pitt Street, Sydney, NSW	604.20	''	05/04/00
Neeloc Pty Ltd, C/- Norman Hardy, 12th Floor, 68 Pitt Street, Sydney, NSW	604.20	''	04/10/00
Mrs Audrey Ellen Newnham, 11 Threadneedle St, Balwyn	190.00	''	05/04/00
Niac Pty Ltd, 76 Winchester Street, Malvern, SA	133.00	''	''
Mr David Clark Nisbet, PO Box 165, Surfers Paradise, Qld	110.20	''	''
Noblelink Administration Services Pty Ltd, "Wyo P/L Kerr Super A/C", 90 Newmans Rd, Templestowe	209.00	''	04/10/00
Noblelink Administration Services Pty Ltd, "Wyo P/L Kerr Super A/C", 90 Newmans Rd, Templestowe	209.00	''	05/04/00
Noel Bennet Homes Pty Ltd, "Provident Fund A/C", PO Box 758, Tamworth, NSW	116.30	''	''
Noel Bennet Homes Pty Ltd, "Provident Fund A/C", PO Box 758, Tamworth, NSW	130.35	''	04/10/00
Ms Matilda Nunn & Ms Lachlan Nunn & Ms Rosemary Nunn, C/- Andrew Nunn, PO Box 119, Port Fairy	114.38	''	05/04/00
Ms Matilda Nunn & Ms Lachlan Nunn & Ms Rosemary Nunn, C/- Andrew Nunn, PO Box 119, Port Fairy	114.38	''	04/10/00
Nycor Engineering Pty Ltd, "Superannuation Fund A/C", 88 Levanswell Road, Morrabbinn	190.00	''	05/04/00
Nycor Engineering Pty Ltd, "Superannuation Fund A/C", 88 Levanswell Road, Morrabbinn	190.00	''	04/10/00
Mr John Martin O'Donohue, PO Box 12, Rochedale, Qld	209.00	''	''
Mrs Suzanne Elizabeth Parry-Okeden, 66 Urquhart Street, Hawthorn	202.54	''	''
Miss Susanne Elizabeth Oliver, Queen Mary Building, Grose Street, Camperdown, NSW	127.11	''	05/04/00
Mrs Patricia Mildred O'Shaughnessy, 38 Macarthy Avenue, Kew	294.88	''	04/10/00
Oxford Technologies Ltd, Attention The Secretary, C/- Happy World House, Sir William Newton Street, Port Louis, Mauritius	212.12	''	05/04/00
Oxford Technologies Ltd, Attention The Secretary, C/- Happy World House, Sir William Newton Street, Port Louis, Mauritius	224.68	''	04/10/00
Palimark Pty Limited, "Pauline Smith SF Account", 7065 Riverview Crescent, Sanctuary Cove, Qld	125.78	''	''
Mr Michael Panting, 5/24 Newcastle Street, Newport	209.00	''	''
Mr Stuart Charles Parker, 18 Rupert Ave, New Town, Tas.	237.69	''	''
Mr Robert Bruce Patterson & Ms Karen Christine Agnes Ferris, C/- Maclean & Patterson Serv' Pty Ltd, 117 Church Street, Hawthorn	826.50	''	05/04/00
Mrs June Grace Paul, 6 Holdsworth St, Woollahra, NSW	683.62	''	04/10/00

Mrs June Grace Paul, 6 Holdsworth St, Woollahra, NSW	683.62	''	05/04/00
Mr Colin Harrison Payne, 11 Ikana Court, Southport, Qld	348.08	''	''
Mr Nigel Hugh Peck, 17 Stonnington Place, Toorak	528.77	''	04/10/00
Mr Barry Reginald Peers, 21 Turrumurra Way, Greenwood, WA	142.88	''	04/10/00
Mr John W. Pennefather, 3 Rembrandt Drive, Middle Cove, NSW	167.58	''	05/04/00
Mr John W. Pennefather, 3 Rembrandt Drive, Middle Cove, NSW	167.58	''	04/10/00
P E R Investments Pty Ltd, 10 Kilpara Court, Mornington	306.66	''	''
Mr Mark Perica, 15 Chapman Street, North Melbourne	120.27	''	''
Mr George Harcourt Perry, 28 Woodhill Link, Jerrabomberra, NSW	224.77	''	''
Mrs Sally Peterson, 33 Clarke Road, Waitara, NSW	156.20	''	''
Mrs Sally Peterson, 33 Clarke Road, Waitara, NSW	139.75	''	05/04/00
Mr James J. Pitt, 7 Kingfield Court, Burwood	149.34	''	04/10/00
Mr James J. Pitt, 7 Kingfield Court, Burwood	149.34	''	05/04/00
Mr Brendan J. Pound, C/- Telstra Locked Bag 6847, Sydney, NSW	242.63	''	04/10/00
Mrs Elaine Jennifer Price, 4/55 Canterbury Rd, Middle Park	256.88	''	''
Mr Ken Price & Mrs Sue Price, "Price Super Fund A/C", Kenmore Hills, Qld	130.35	''	''
Mr Ken Price & Mrs Sue Price, "Price Super Fund A/C", Kenmore Hills, Qld	116.30	''	05/04/00
Production Brazing Co Australia Pty Ltd, "Roberg Super Fund A/C", C/- John J. Varcoe, 25 Rowe Street, Alphington	190.00	''	04/10/00
Mr Kenneth Ronald Ian Prowse, "Ardoyne", Deniliquin, NSW	436.46	''	''
Mr Kenneth Ronald Ian Prowse, "Ardoyne", Deniliquin, NSW	390.41	''	05/04/00
The Public Trustee, Stewart House, 24 Kingsway, London WC2B 6JX United Kingdom	1,211.30	''	04/10/00
The Public Trustee, Stewart House, 24 Kingsway, London WC2B 6JX United Kingdom	1,181.10	''	05/04/00
R & K Lobb Investments Pty Ltd, "Superfund Account" C/- Mr R Lobb, 20 Portland Street, Dover Heights, NSW	224.77	''	04/10/00
Ramist Pty Ltd, "Ramist Super Account", Lbw, (Attention Mr H Davis), PO Box 4115, Geelong	114.00	''	''
Mrs Susan Waite Redman, 25 Lennox St, Gordon, NSW	380.00	''	''
M/s Jean Alice Reeves, C/- Mr R. Reeves, 13 Corniche Road, Church Point, NSW	275.88	''	''
M/s Jean Alice Reeves, C/- Mr R. Reeves, 13 Corniche Road, Church Point, NSW	275.88	''	05/04/00
Mrs Janice Annette Reynolds, 7 Middle Street, Caves Beach, NSW	190.00	''	''
Mrs Janice Annette Reynolds, 7 Middle Street, Caves Beach, NSW	190.00	''	04/10/00
Mr John Reynolds, C/- Mr & Mrs P. E. L. Cribb, 11 Nabisac Place, Westleigh, NSW	151.62	''	05/04/00
Rich Superannuation Fund Pty Ltd, C/- Gresham Partners Ltd, 5th Floor, 175 Macquarie Street, Sydney, NSW	389.88	''	05/04/00

Mrs Janet Richardson, 5 Ewens Court, Mount Gambier, SA	111.15	''	''
Mrs Jennifer Mary Morrice Riedel, 33 Faversham Road, Canterbury	228.76	''	''
Mrs Jennifer Mary Morrice Riedel, 33 Faversham Road, Canterbury	228.76	''	04/10/00
Mr David Ritchie, PO Box 94, Annandale, NSW	353.59	''	''
Mr David Ritchie, PO Box 94, Annandale, NSW	353.59	''	05/04/00
Ms Therese Rod Po Box 1031 Buderim Qld	104.50	''	04/10/00
Mr David Scott Rodgers, 75 Waverley St, Moonee Ponds	380.00	''	''
Mr David Scott Rodgers, 75 Waverley St, Moonee Ponds	380.00	''	05/04/00
Mr Gregory Richard Rowe & Mrs Helen Louise Rowe, 11 Furber Place, Davidson, NSW	129.01	''	''
Ruddington Holdings Pty Ltd, "A/C Richard Large Super Fund", C/- Herbert Geer & Rundle, 389 Bourke Street, Melbourne	152.00	''	04/10/00
Mrs Jane Kathleen Rudduck, "Late Herbert C. Rudduck A/C", C/- Munro Accountants, PO Box 1110, Broadbeach, Qld	287.21	''	05/04/00
Mr Ian Andrew Kincaid Russell, C/- Morgan Stockbroking MPS, GPO Box 582, Brisbane, Qld	106.97	''	''
Mr Ellery Lytton Maurice Ryan, 79 Lisson Grove, Hawthorn	1,913.68	''	''
Mr Antony B. Sale, Old Sackville Rd, Wilberforce, NSW	315.40	''	''
Mr Antony B. Sale, Old Sackville Rd, Wilberforce, NSW	315.40	''	05/04/00
Mr John Adrian Sambell & Mrs Rosemarie Sambell, 11 Wilson Street, Glen Iris	285.00	''	04/10/00
Mr Phillip Orr Sawers, Unit 46, 87 Springwood Road, Springwood, Qld	224.77	''	''
Mr Frank Scarfo & Mrs Helen Collins, "Tlo Executive Super A/C", C/- 61 Henley Beach Road, Mile End, SA	232.55	''	05/04/00
Mr Frank Scarfo & Mrs Helen Collins, "Tlo Executive Super A/C", C/- 61 Henley Beach Road, Mile End, SA	260.20	''	04/10/00
Ms Anne-Marie Schiller, 1 Avenue Voltaire, 78600 Maisons-Laffitte, France	389.50	''	05/04/00
Mrs Sheila C. Schneider, 21 Lansdown St, East St Kilda	100.32	''	04/10/00
Mrs Sheila C. Schneider, 21 Lansdown St, East St Kilda	100.32	''	05/04/00
Mrs Ursula Maria Schone, PO Box 184, St Leonards, NSW	285.00	''	''
Mr George Paul Schwarz, 13 Kyora Parade, North Balwyn	237.88	''	04/10/00
Mr Emanuele Scordio, 7 Karamarra Place, Kingsley, WA	132.24	''	''
Mr Mark Selle, 9 Boolarra Avenue, Clifton Springs	101.08	''	05/04/00
Mr Anthony Johnson Seppelt, 18 Darling Street, Paddington, NSW	172.43	''	''
Mr Anthony Johnson Seppelt, 18 Darling Street, Paddington, NSW	192.83	''	04/10/00
Serrl Nominees Pty Ltd, Office One, 99 Bay Street, Brighton	190.00	''	05/04/00
M/s Jill Robyn Jan Sewell, McIntyre Road, Nayook	760.00	''	04/10/00
Mr Malachi Seymour, 1137 Chittering Rd, Bullsbrook, WA	131.82	''	''
Mr Malachi Seymour, 1137 Chittering Rd, Bullsbrook, WA	118.27	''	05/04/00
Mr Keith Shane, 18 Gracehill Avenue, Burwood	132.24	''	04/10/00
Lee Sharp, 3 Whittens Lane, Doncaster	127.11	''	''
Mrs Denise E. Sheridan, 62 Homebush Road, Strathfield, NSW	815.48	''	05/04/00

Miss Mildred Mary Simmons, C/- Stella Maris Hostel, 6 Coast Avenue, Cronulla, NSW	268.66	''	04/10/00
Miss Mildred Mary Simmons, C/- Stella Maris Hostel, 6 Coast Avenue, Cronulla, NSW	268.66	''	05/04/00
Mrs Elizabeth Mary Sinkinson, 7 Dovier Place, Leopold	133.00	''	''
Mr Darren Mccrae Slocomb, PO Box 1446, Hervey Bay, Qld	186.58	''	''
Mrs Annie Smith, "Chosen", PO Box 41, Beverley, WA	237.50	''	04/10/00
Mrs Annie Smith, "Chosen", PO Box 41, Beverley, WA	237.50	''	05/04/00
Mr David Hoseason-Smith, Unit 2, 5 Rocklands Drive, Tiwi, NT	119.70	''	04/10/00
Mr Roger Smith & Ms Rebecca Keene, "Oban Super Fund A/C", 15 Toorak Road, South Yarra	129.77	''	05/04/00
Mr Richard L. Spence, 5 Stewart Street, Ormond	100.70	''	04/10/00
Ms Lesley Anne Starky, 58/121 Rathdowne Street, Carlton	190.00	''	''
Ms Lesley Anne Starky, 58/121 Rathdowne Street, Carlton	190.00	''	05/04/00
Mrs Betty Christine Steele & Mr James William Fitzwalter Thomson PO Box 18024, Collins Street East, Melbourne	1,207.64	''	04/10/00
M/s Joanne Robyn Stephan, 11A Clark Street, Khandallah, Wellington, New Zealand	857.37	''	''
M/s Joanne Robyn Stephan, 11A Clark Street, Khandallah, Wellington, New Zealand	836.00	''	05/04/00
Mr Charles Warden Stewart, Oruaiti Rd1, Mangonui, Northland, New Zealand	142.45	''	''
Mr Charles Warden Stewart, Oruaiti Rd1, Mangonui, Northland, New Zealand	146.10	''	04/10/00
Ms Deborah Elizabeth Stewart, 24/16-20 Milton St, Elwood	104.45	''	''
Mr Simon Stonier, "The Brian Stonier Family A/C", 24 Battery Street, Clovelly, NSW	190.00	''	05/04/00
Sucgang Nominees Pty Ltd, 44 Roland Avenue, Baulkham Hills, NSW	225.91	''	04/10/00
M/s Jennifer Anne Suter, 131 Loongana Avenue, Glenroy	168.72	''	05/04/00
Mr Russell Symons, 36 Daisy Street, Essendon	256.88	''	''
Mr Robert Richard Taylor, 19 Campbell St, Eastwood, NSW	225.53	''	04/10/00
Mr Robert Richard Taylor, 19 Campbell St, Eastwood, NSW	225.53	''	05/04/00
Mr Peter Tetas, 28A High Street, Glen Iris	238.96	''	''
Mr Peter Tetas, 28A High Street, Glen Iris	267.56	''	04/10/00
Mr Bernard Thome, 37 Rue Du Baty, 1428 Lillois, Belgium	108.03	''	''
Mr Bernard Thome, 37 Rue Du Baty, 1428 Lillois, Belgium	105.34	''	05/04/00
Mr Duncan Alfred Thorn, 30 Barrow Street, Coburg	111.15	''	04/10/00
Mr Peter John Thorp, PO Box 664, Spit Junction, NSW	247.03	''	05/04/00
Mr Peter John Thorp, PO Box 664, Spit Junction, NSW	276.13	''	04/10/00
Miss Katherine H. Timcke, 10 North East Rd, Walkerville, SA	265.05	''	''
Mrs Karen Louise Tokutake, 22 Rochdale Avenue, Tarragindi, Qld	190.00	''	05/04/00
Mrs Muoi Tran, 17 Neville Street, Lidcombe, NSW	171.00	''	04/10/00
Estate Late Margaret Trevenen, C/- Gr Herbert & Co, Level 1, 8 Bluff Road, Black Rock	180.88	''	05/04/00
Mr Bradley Turner, PO Box 393, Narellan, NSW	114.00	''	''
Mr Gary John Turner, "Superannuation A/C", PO Box 1460, Central Park	313.88	''	''
Mr Robert Tutton, 18 Merton Stree, Ivanhoe Twenty Third Emotion Pty Ltd,	237.31	''	04/10/00

2 Wridgway Avenue, Burwood Twenty Third Emotion Pty Ltd,	190.00	”	05/04/00
2 Wridgway Avenue, Burwood Est Late Balmukund Upadhyaya & Mrs Kantadevi B. Upadhyaya,	190.00	”	04/10/00
23 Ridgeway Gardens, Redbridge Ilford 1G4 5HJ UK Van De Pol Stockfeeds (Aust) Pty Ltd, “Superannuation Fund A/C”,	272.54	”	05/04/00
Factory 1 – Bulla Road East, North Essendon Van De Pol Stockfeeds (Aust) Pty Ltd, “Superannuation Fund A/C”,	104.50	”	”
Factory 1 – Bulla Road East, North Essendon Vivienne Ross & Associates Pty Ltd, “Vivienne Ross Assoc S/F A/C”,	104.50	”	04/10/00
11 Tennyson Street, Elwood Mr David E. Waddell, PO Box 199, Beaudesert, Qld	332.88	”	05/04/00
Mr David E. Waddell, PO Box 199, Beaudesert, Qld	130.91	”	”
Mr David E. Waddell, PO Box 199, Beaudesert, Qld	130.91	”	04/10/00
Mrs Helen W. Wade, 5 Iris Street, Burwood	386.65	”	”
Mr Stephen John Wade, 54 Capon Street, Chadstone	100.70	”	05/04/00
Mr Stephen John Wade, 54 Capon Street, Chadstone	100.70	”	04/10/00
M/s Voila Joy Walker ,1/47 Riversdale Road, Hawthorn Dr Alfred Wall, “A/C Estate A. H. Wall”,	184.11	”	”
101 Locksley Road, Ivanhoe Dr Alfred Wall, “A/C Estate A. H. Wall”,	1,325.63	”	”
101 Locksley Road, Ivanhoe Mrs Thelma Margaret Wall, 101 Locksley Road, Ivanhoe	1,325.63	”	05/04/00
Mrs Thelma Margaret Wall, 101 Locksley Road, Ivanhoe	593.37	”	04/10/00
Mrs Thelma Margaret Wall, 101 Locksley Road, Ivanhoe Mrs Kathleen G. Wallwork,	593.37	”	05/04/00
22 Rosny Esplanade, Montagu Bay, Tas.	266.00	”	04/10/00
Mrs Pamela D. Walter, C/- Mr J. O. Blades, Unit 61, Cutler Village, Colooli Road, Narrabeen, NSW	157.51	”	”
Mrs Pamela D. Walter, C/- Mr J. O. Blades, Unit 61, Cutler Village, Colooli Road, Narrabeen, NSW	157.51	”	05/04/00
Mrs Carole Jean Walters, 7 Edgecliffe Esplanade, Seaforth, NSW	243.39	”	04/10/00
Mrs Carole Jean Walters, 7 Edgecliffe Esplanade, Seaforth, NSW	243.39	”	05/04/00
Webb Pty Ltd, “Webb Family A/C”, Factory 1, 45 Gilbert Park Drive, Knoxfield	380.00	”	”
Miss Alison Florence Wenck, 13B Southern Commercial Building, 13 Luard Road, Wanchai, Hong Kong	101.08	”	05/04/00
Miss Alison Florence Wenck, 13B Southern Commercial Build Ing, 13 Luard Road, Wanchai, Hong Kong	107.06	”	04/10/00
Wesbran Pty Ltd, “Super Fund A/C”, Shop 16, Mudgeeraba Market, Swan Lane, Mudgeeraba, Qld	104.50	”	”
Wesbran Pty Ltd, “Super Fund A/C”, Shop 16, Mudgeeraba Market, Swan Lane, Mudgeeraba, Qld	104.50	”	05/04/00
Mr Arthur White, C/- Mr G Hancock, 20 Boya Crescent, Boya, WA	344.28	”	”
Mr Arthur White, C/- Mr G Hancock, 20 Boya Crescent, Boya, WA	344.28	”	04/10/00



Mr Graham J. Whitehead, 5 Barongarook Road, Maryknoll Whiteholme (Canberra) Pty Limited,	100.70	”	”
“Decler Super Fund A/C”, 90 Appel Crescent, Fadden, ACT	389.88	”	05/04/00
Miss Carey B. E. Whitley, 2 Brooksby Street, London N1 1HA United Kingdom	454.07	”	04/10/00
Mr Marcus Boyd Willson, C/- Stringy Brae, PO Box 35, Sevenhill Via Clare, SA	123.50	”	05/04/00
Mr Marcus Boyd Willson, C/- Stringy Brae, PO Box 35, Sevenhill Via Clare, SA	123.50	”	04/10/00
Exors Late Alexander H. Wilson, C/- Mrs Winifred M. G. Wilson, 134 Arney Road, Remuera, Auckland, New Zealand	491.57	”	05/04/00
Exors Late Alexander H. Wilson, C/- Mrs Winifred M. G. Wilson, 134 Arney Road, Remuera, Auckland, New Zealand	504.14	”	04/10/00
Mr Murray Ross Wilson, 2/90 Haverstock Road, Mt Albert, Auckland, NZ	120.03	”	”
Mr Murray Ross Wilson, 2/90 Haverstock Road, Mt Albert, Auckland, NZ	117.04	”	05/04/00
Mr Ronald Clive Wilson, 136-142 Clifton Drive, Jimboomba, Qld	303.81	”	04/10/00
Mrs Susan Elizabeth Wilson, 12 Glebe Avenue, Cheltenham	342.00	”	”
Mr Carl Wilton & Mrs Mary Jo Wilton, 4 Castletown Way, Esperance, WA	111.50	”	”
Est Mr George Harold Wiltshire, C/-Pearce Webster Dugdales, 4th Floor, 379 Collins Street Melbourne	300.77	”	”
Winomond Pty Limited, “Langford Super Fund A/C”, 12 Gell Street, Bacchus Marsh	161.88	”	”
Mr Jasper Lewis Wolfe & Miss Zoe Alexandra Wolfe, 55 Ellena St, Paddington, Qld	104.50	”	05/04/00
Mrs May Lian Wong, 8 Jalan SS 21/1 Damansara Utama, Selangor, Malaysia	249.96	”	”
Mrs Robyn Patricia Woodhall, 23 Olympus Drive, South Croydon	129.77	”	”
Mr Barry William Woods, 43 Devoran Street, Albany Creek, Qld	142.88	”	”
Mrs Yvonne Marion Worthington, 26 Lyndhurst Street Richmond	161.88	”	”
Mrs Yvonne Marion Worthington, 26 Lyndhurst Street Richmond	161.88	”	04/10/00
Estate Late Henry Reed King Youlden, C/- Aitken Walker & Strachan, GPO Box 5453CC Melbourne	294.50	”	05/04/00
Dr Angelina Wen Tzu Zea, 10 Chatswood Avenue, Chatswood, NSW	117.15	”	04/10/00

02073

CONTACT: ELAINE V. HARE, PHONE: (03) 9611 5714.

**Unclaimed Moneys Act 1962**

Register of Unclaimed Moneys held by the —

<i>Name of Owner on Books and Last Known Address</i>	<i>Total Amount Due to Owner</i>	<i>Description Of Unclaimed Money</i>	<i>Date when Amount became Payable</i>
ASHTON MINING LIMITED			
	\$		
Miss Audrey Appleton, PO Box 403, Cheltenham	380.00	Cheque	14/09/00
M/s Phillipa J. Bailey, Moss Vale, PO Box 325, Scone, NSW	111.98	"	20/04/00
Mr Oei Chin Bok, C/- Mr C K Foo, 2nd Floor, Hong Kong Bank Bldg, Station Road, Ipoh Perak, Malaysia	106.65	"	14/09/00
Estate Late Robert W. Rankine, Mr Brian L. Brain, 23 High Street, Seacliff Park, SA	134.40	"	"
Mr Daniel Chui & Mrs Diana Chui, 18 Somme Street, Devonport, Tas.	139.95	"	"
Mr William Edward Coulston, 6 Karen Place, Ingleburn, NSW	218.60	"	"
Mr William Edward Coulston, 6 Karen Place, Ingleburn, NSW	109.30	"	20/04/00
Donald Ross Coutts & Julie Irene Coutts, 60 Norman Drive, Chermside, Qld	106.65	"	14/09/00
Mr Robin K. J. Coventry, 15 Brighton Street, Sandringham	175.00	"	"
Cycas Pty Limited, 23 Raglan Street, Mosman, NSW	125.00	"	20/04/00
Mr Philippe Defever, Chemin Des Deux Maisons, 75/2 1200 Bruxelles, Belgium	196.83	"	"
Mr James David Geddes, Unit 6, 8 Phillip Street, Fannie Bay, NT	120.00	"	"
Mrs Lucy Gemes, Unit 1A, 7 St Marks Road, Darling Point NSW	325.00	"	14/09/00
Mrs Lucy Gemes, Unit 1A, 7 St Marks Road, Darling Point NSW	162.50	"	20/04/00
Mr John Robert Gillespie & Mrs Estelle Elizabeth Gillespie, 4/200 Murrumbeena Road, Murrumbeena	150.00	"	"
G P Nominees Sdn Bhd, Level 2, Block F, North Damansara Town Centre Damansara Heights 50490 Kuala Lumpur	537.30	"	14/09/00
G P Nominees Sdn Bhd, Level 2, Block F, North Damansara Town Centre Damansara Heights 50490 Kuala Lumpur	268.65	"	20/04/00
Mr Neil Leslie Greiner, PO Box 173, Hawera, New Zealand	106.65	"	14/09/00
Guimaco Nominees Pte Limited, 4 Raffles Quay #03-00 Finlayson House, Singapore 0104	158.20	"	"
Mr Wayne Hillier, 148 Nicholson Street, Goulburn, NSW	496.15	"	"
Kuan Lee Khoo, 14 Faber Drive, off Upper Ayer Rajah Road, Singapore 0512	349.95	"	"
Kuan Lee Khoo, 14 Faber Drive, off Upper Ayer Rajah Road, Singapore 0512	174.98	"	20/04/00
Mr Leon Kleinman, 47 Mountain View Parade, New Lambton Heights NSW	120.00	"	"
Estate Late Robert Lambie, C/- Plaza Floor, National Mutual, 447 Collins Street, Melbourne	106.65	"	14/09/00

Mr Ian E. Lediard, 267 Main Highway, Ellerslie, Auckland 5 NZ	420.00	”	”
Mr Jenö Leky, Rm 9, Bks 45 Bsd, Mount Isa, Qld	133.35	”	”
Mr Khui Loong, C/- Wing On Company Limited, 55 Leech Street, Ipoh Perak West Malaysia	210.00	”	”
Mr Khui Loong, C/- Wing On Company Limited, 55 Leech Street, Ipoh Perak West Malaysia	105.00	”	20/04/00
Mr William Marty, PO Box 2029, Mount Isa, Qld	250.00	”	14/09/00
Mr Kenneth George May, PO Box 988, Canberra City, ACT	148.40	”	”
Mr Eric Paul McClintock, Level 21, 1 O’Connell Street, Sydney NSW	220.00	”	”
Mr Graham McElvenny & Mr Peter Drury & Mr Anthony De Rosa, 18/11 Elamang Ave, Kirribilli, NSW	106.65	”	”
Mr Abuli, son of H Motiwala, 27 Pesiaran Ampang Kuala Lumpur, 16-07 Malaysia	128.00	”	”
Miss Amanda L. Muir Cheshunt, 102 Highfield Road, Camberwell	106.68	”	20/04/00
Miss Amanda L. Muir Cheshunt, 102 Highfield Road, Camberwell	213.35	”	14/09/00
Mutual Trust Pty Ltd, PO Box 12, Collins Street West, Melbourne	1,048.60	”	”
Dr Soon Gan Ng, C/- Teo Cheng Hai, Orchard Point, PO Box 420, Singapore 9123	139.95	”	”
Dr Soon Gan Ng, C/- Mr Teo Cheng Hai, Serangoon Central PO, PO Box 731, Singapore 915508 Singapore	150.00	”	”
Mrs Sonia Leanne Paterson, 48 Hobart Ave, Umina, NSW	362.50	”	20/04/00
Thambo Ratnam, 91 Jalan Maarof Bangsar 59000 Kuala Lumpur, Malaysia	233.30	”	14/09/00
Thambo Ratnam, 91 Jalan Maarof Bangsar 59000 Kuala Lumpur, Malaysia	116.65	”	20/04/00
Richardson Greenshields of Canada (Pacific) Limited, 18th Floor, China Building, 29 Queens Road, Central Hong Kong	106.65	”	14/09/00
Mrs Lea Rockman, Flat 3, 8 St Aubins Ave, North Caulfield	176.40	”	”
Ms Catherine Anne Rosair, “Catherine Rosair Family A/C”, Unit 7, 8 Grant Place, Port Hedland, WA	125.00	”	”
Mr Reginald Allen Rowe, 20 Ardara Street, Bracken Ridge, Qld	143.50	”	”
Mrs Jane Kathleen Rudduck, “Est Herbert Charles Rudduck”, C/- Munro Accountants, PO Box 1110, Broadbeach, Qld	133.33	”	20/04/00
Salorex Pty Ltd, 450 Little Collins Street, Melbourne	133.35	”	14/09/00
Mr Shankar Sthipam Santhirasthipam, No 1d Jalan Kelicap 6/4d, 40000 Shah Alam Selangor D E Malaysia	150.00	”	”
Mr David Kit Shearwood, B604/780 Bourke Street, Redfern, NSW	200.00	”	20/04/00
Dr Paul John Vincent Spano, “Julian Joseph Jardine A/C”, PO Box 2114, Meadow Heights	125.00	”	”
Mr Stanley Stepien, 303/112 Goderich Street, East Perth WA	139.95	”	14/09/00
Mr Philip Tan, C/- Mr C. K. Foo, 2nd Floor, Hong Kong Bank Bldg, Station Road, Ipoh Perak, Malaysia	106.65	”	”
Mr Geoffrey Norman Francis Taylor, 302 Moore Park Road, Paddington, NSW	286.95	”	”

Mr Geoffrey Norman Francis Taylor, 302 Moore Park Road, Paddington, NSW	143.48	”	20/04/00
Mrs Eva Tee, C/- S. Chiang & Associates, PO Box 597, Kenmore, Qld	105.00	”	”
Mr Ratnam Thamboo, 91 Jalan Maarof, Bangsar 59000 Kuala Lumpur, Malaysia	349.95	”	14/09/00
Mr Ratnam Thamboo, 91 Jalan Maarof, Bangsar 59000 Kuala Lumpur, Malaysia	174.98	”	20/04/00
Mr Adrian Van Der Kamp & Mrs Stella Van Der Kamp, “Hamabon Super Fund A/C”, 35 Short St, Mount Isa, Qld	400.00	”	”
Mr Douglas Webster, No 3 Jalan, 14/3 Taman Tun Abdul Razak Ampang Jaya 68000 Ampang, Kuala Lumpur	139.95	”	14/09/00
Mrs Roma Gertrude Weiss, 18 Horace St, St Ives, NSW	311.85	”	”
Mr Khor Ching Weng, 4 Jalan Mas Satu Johore Bahru Johore, Malaysia	106.65	”	”
Mr Peter Wimmer, C/- Unit 26, 16-32 Monavale Road, Mona Vale, NSW	156.65	”	”
Doreen Woodward, 10 Heather Place, Hornsby Heights, NSW	139.95	”	”

02074

CONTACT: ELAINE V. HARE, PHONE: (03) 9611 5714

### Unclaimed Moneys Act 1962

Register of Unclaimed Moneys held by the —

<i>Name of Owner on Books and Last Known Address</i>	<i>Total</i>		<i>Date</i>
	<i>Amount</i>	<i>Description</i>	<i>when</i>
	<i>Due to</i>	<i>Of Unclaimed</i>	<i>first</i>
	<i>Owner</i>	<i>Money</i>	<i>became</i>
			<i>Payable</i>
AUSTRALIAN UNITED INVESTMENT COMPANY LTD			
\$			
Estate Late Elizabeth Cowling, C/- Price Higgins, PO Box 180, Geelong	163.13	Cheque	14/04/00
Dr David Owen Crompton, 97 Brougham Place, North Adelaide, SA	6,028.80	”	09/10/00
Mrs Audrey Esther Geschke, 42 Andrew Stree, Oakleigh	288.00	”	14/04/00
Brenda McIntosh, 101 Canterbury Road Canterbury	583.44	”	09/10/00
Mr Alwyn James Seeley, 9 Armagh Street, Hamilton, NZ	120.00	”	”
Sudan Investment Pty Ltd, “Superannuation Fund Account”, 9 Beaumont Road, West Killara, NSW	168.00	”	”

02075

CONTACT: ELAINE V. HARE, PHONE: (03) 9611 5714.

**Unclaimed Moneys Act 1962**

Register of Unclaimed Moneys held by the —

<i>Name of Owner on Books and Last Known Address</i>	<i>Total Amount Due to Owner</i>	<i>Description Of Unclaimed Money</i>	<i>Date when Amount first became Payable</i>
AV JENNINGS HOMES LIMITED			
	\$		
Mr Jamal Abdul Nasir Bin Ali, Block 458 #05-294 Tampines St 42, Singapore 1852, Republic of Singapore	127.50	Cheque	18/07/00
Mr Peter Stephen Allen, 3 Camarsh Drive, Murrumba Downs, Qld Est Late Alec Brown, C/- Goldie Kelmann, PO Box 383, Elsternwick	192.83	"	"
Mr Suhir Chellappan, Apt Blk 471, Jurona West St 41, Singapore 2264, Republic of Singapore	127.50	"	"
Mr Cheong Kok Keen, Blk 133, Geylang East Avenue 1, #15-207 Singapore 11438, Republic of Singapore	255.00	"	"
Mr Chris Keys, 17/9 Banks Street, Meadowbank, NSW	225.00	"	"
Ms Wan Fern Kuan, 4 Lorong Hujan Satu Taman, Overseas Union, Kuala Lumpur 58200, Malaysia	127.50	"	"
Mr Christurajan Leon, Blk 241, #04-241 Bishan St 22, Singapore 2057, Republic of Singapore	382.50	"	"
Mr Lye Hock Paul Lim, Apt Blk 545, 5142 Jurong West , Singapore 2264, Republic of Singapore	127.50	"	"
Hamish Wayne McGregor, PO Box 6900, Wellesley Street, Auckland, New Zealand	191.25	"	"
Ms Lee Keow Kathryn Ong, Blk 800 #03-4387, Yishun Ring Road, Singapore 2776, Republic of Singapore	127.50	"	"
Mr Toon Kam Ong, Lot 26, Jalan Tasek Tasek Ind Estate Ipoh Perak 31400 Malaysia	127.50	"	"
Sun Hung Kai Nominees Pty Limited, 20 Collyer Quay #18-01, Tung Centre, Singapore 0104	222.17	"	"
Sunbid Pty Limited, 46 Rangers Avenue, Mosman, NSW	3,750.00	"	"
Mr Lyn Li Andrea Yeo, 61 Regent Street, Singapore 2879, Republic of Singapore	255.00	"	"

02076

CONTACT: ELAINE V. HARE, PHONE: (03) 9611 5714.

**Unclaimed Moneys Act 1962**

Register of Unclaimed Moneys held by the —

<i>Name of Owner on Books and Last Known Address</i>	<i>Total Amount Due to Owner</i>	<i>Description Of Unclaimed Money</i>	<i>Date when Amount first became Payable</i>
AXA ASIA PACIFIC HOLDINGS LIMITED			
\$			
A & B Management Pty Ltd, PO Box 2186, Fortitude Valley, Qld	363.56	Cheque	24/07/00
A & B Management Pty Ltd, PO Box 2186, Fortitude Valley, Qld	363.56	"	29/02/00
Abba Bay Pty Ltd, 52 The Esplanade, Sylvania Heights, NSW	134.46	"	24/07/00
Abba Bay Pty Ltd, 52 The Esplanade, Sylvania Heights, NSW	134.46	"	29/02/00
Abbeyson Pty Ltd, 115 Wellington Street, Windsor	288.00	"	24/07/00
Abramovich Pty Ltd, PO Box 216, Potts Point, NSW	180.00	"	"
Abramovich Pty Ltd, PO Box 216, Potts Point, NSW	180.00	"	29/02/00
Estate Late Geoffrey Charles Adams, C/- Ryan Maloney Anderson, PO BOX 5041, Mildura	102.83	"	24/07/00
Mr Stanley Leslie Adler, 8 Cambridge Ave, North Rocks, NSW	100.50	"	"
Akuna Investments Pty Ltd, Johnsons Road, Yolla, Tas.	326.41	"	29/02/00
Akuna Investments Pty Ltd, Johnsons Road, Yolla, Tas.	326.41	"	24/07/00
Ms Rosemary Margaret Allen, Compton Via Mt Gambier, SA	132.39	"	"
Ms Rosemary Margaret Allen, Compton Via Mt Gambier, SA	132.39	"	29/02/00
Mr Mark William Annear, PO Box 1448, Karratha, WA	107.64	"	"
Mr Mark William Annear, PO Box 1448, Karratha, WA	107.64	"	24/07/00
Mr Kenneth Alexander Aphorpe, 9 Bulimba Street, Bulimba, Qld	126.63	"	"
Mr Kevin John Archer, 7334 Delta Lake Drive, Charlotte, North Carolina 28215 USA	112.23	"	29/02/00
Arwco Nominees Pty Ltd, "Brown A/C" 1/155 Brisbane Street, Dubbo NSW	936.27	"	"
Arwco Nominees Pty Ltd, "Brown A/C" 1/155 Brisbane Street, Dubbo NSW	936.27	"	24/07/00
Mr Stephen Axelsen, C/- Fermentation Industries, 1 Ferndell Street, Granville NSW	165.96	"	"
Mr Stephen Axelsen, C/- Fermentation Industries, 1 Ferndell Street, Granville, NSW	165.96	"	29/02/00
Mr Leo Rimantas Balbata, 2 Raleigh Street, Essendon	102.69	"	24/07/00
Mr Robert Glenn Barkman, "Barkman Family A/C", 45 Glen Road, Oatley NSW	121.14	"	"
Mr Robert Glenn Barkman, "Barkman Family A/C", 45 Glen Road, Oatley NSW	121.14	"	29/02/00
Mr James Arthur Bartholomaeus, Pine Creek Station, Cockburn, SA	102.02	"	"
Mr Grant Lee Bartimote, 25 Rosemary Lane, Orange, NSW	112.32	"	24/07/00
Mr Richard Leslie Belcher, Unit 1, 1 Julia Court, Collinswood SA	109.17	"	29/02/00

Mr Gregory Gordon Bennedick, 55 King St, Moura, Qld	155.25	''	24/07/00
Mr Peter Bennison & Mr Sarah Bennison, 19 Lawson Street, Hawthorn East	280.80	''	29/02/00
Mr Hugh Beveridge, PO Box 173, Tom Price, WA	182.75	''	24/07/00
Mr Brian Richard Billings, 4 Pituri St, Bracken Ridge, Qld	157.23	''	29/02/00
Mr Brian Richard Billings, 4 Pituri St, Bracken Ridge, Qld	157.23	''	24/07/00
Mr Wayne Bishop & Mrs Laurel Bishop, "W & L Bishop S/F A/C", C/- Kra Financial Group P/L, Level 1/180 Albert Road, South Melbourne	112.50	''	''
Dr Alexander John Roberts Black, 770 Lake Rd, Connewarre	183.55	''	''
Dr Alexander John Roberts Black, 770 Lake Rd, Connewarre	183.55	''	29/02/00
Mr Nicholas Scott Blake, 116 Shields Street, Flemington	105.71	''	24/07/00
Mr Reginald James Bond & Mrs Barbara Bond, 5 Boyland Crt, Box Hill North	260.96	''	''
Mr Geoffrey Bontoft, Alderton Via Condamine. Qld	144.77	''	''
Miss Joy Brann, PO Box 12, Wembley, WA	125.73	''	''
British International Trading Pty Ltd, 97A Church Street, Castle Hill, NSW	315.00	''	29/02/00
British International Trading Pty Ltd, 97A Church Street, Castle Hill, NSW	315.00	''	24/07/00
Mr Terence Bromley, 27 Barrett Dr, Wandina, Geraldton, WA	116.28	''	29/02/00
Mrs Dawn Brown, 2 Ocean Road, Manly, NSW	225.00	''	''
Mr Stephen Roger Brown, 4 Kalka Street, North Balwyn	101.30	''	''
Mr John Errol Burgemeister, 414 South Terrace, South Fremantle, WA	459.72	''	24/07/00
Mr John Errol Burgemeister, 414 South Terrace, South Fremantle, WA	459.72	''	29/02/00
Mr Edgar Martin Burnard, 10 Lurnea Crescent, Valentine, NSW	177.08	''	''
Mr Maurice Burns, PO Box 436, Karratha, WA	160.47	''	''
Mr Maurice Burns, PO Box 436, Karratha, WA	160.47	''	24/07/00
Mr William Cameron & Mrs Dawn Cameron, 29 Pacific Drive, Banksia Beach, Qld	226.22	''	''
Dr Michael James Cannon, 9 Norman Street, Mangerton, NSW	147.35	''	''
Caravaggio Pty Ltd, "Jules Wynhausen S/Fund A/C", 20 Glenview Street, Paddington, NSW	181.35	''	''
Mrs Diana Maryse Carr, 280 Lesmurdie Rd, Lesmurdie, WA	101.66	''	''
Mr Keith Donald Carr, 23 Mossman Street, Taringa, Qld	123.26	''	29/02/00
Carrington Family Investments Pty Ltd, 52 Davison Road, Wilson Beach, Qld	102.07	''	''
Mrs Patricia B. A. Carrington, 52 Davison Road, Wilson Beach, Qld	151.61	''	''
Mr Louis Charles Cherote, 2 Kanangra Crescent, Ruse, NSW	143.91	''	24/07/00
Mr Louis Charles Cherote, 2 Kanangra Crescent, Ruse, NSW	143.91	''	29/02/00
Estate Late Fredrick Sue Toy Chin, Unit 4, 6/8 Houston Street, Larrakeyah, NT	170.28	''	''
Mr Henry Francis Chow, PO Box 1331, Lae, PNG	150.63	''	24/07/00
C K Clothing Pty Ltd, 13-17 Hillwin Street, Reservoir	282.20	''	''
C K Clothing Pty Ltd, 13-17 Hillwin Street, Reservoir	282.20	''	29/02/00
Mrs Lesley Clarke, 365 St Kilda Street, Brighton	128.61	''	24/07/00
Mr Victor Edward Clifford, 30 Cornish Ave, Killarney Vale, NSW	105.03	''	29/02/00

Mr Victor Edward Clifford, 30 Cornish Ave, Killarney Vale, NSW	105.03	''	24/07/00
Clover Enterprises Inc, Avocats au Barreau de Geneve, Rue Tour-De-L'ile, 1204 Geneve, Switzerland	1,480.50	''	29/02/00
Mr Herbert George Coaker, PO Box 55, Morawa, WA	273.06	''	''
Mrs Jill Estelle Coleman, 4 St Georges Tce, Battery Pt., Tas.	119.66	''	''
Complete Tape Solution Pty Ltd, "Super Fund A/C", Box M77 Post Office, Monash Park, NSW	154.94	''	24/07/00
Complete Tape Solution Pty Ltd, "Super Fund A/C", Box M77 Post Office, Monash Park, NSW	154.94	''	29/02/00
Mrs Suzanne Elizabeth Conners, 12/301 St George Street, Sydney, NSW	101.16	''	''
Mrs Suzanne Elizabeth Conners, 12/301 St George Street, Sydney, NSW	101.16	''	24/07/00
Mr William John Conolly, 24 Stratheden Avenue, Kellyville, NSW	275.13	''	29/02/00
Mrs Grace Nancy Cox, 48 Spowers Street, Bongaree, Bribie Island, Qld	292.14	''	''
Mrs Grace Nancy Cox, 48 Spowers Street, Bongaree, Bribie Island, Qld	292.14	''	24/07/00
Mr Jack Crabtree, 25 Amazon Place, Werribee	128.66	''	29/02/00
Mr Jack Crabtree, 25 Amazon Place, Werribee	128.66	''	24/07/00
Mr Michael Daddo & Mr Peter Davies, "Austock Super Fund Account", Level 1, 350 Collins Street, Melbourne	225.00	''	''
Mr Michael Daddo & Mr Peter Davies, "Austock Super Fund Account", Level 1, 350 Collins Street, Melbourne	225.00	''	29/02/00
Mr John Dakis, 48 Middle Crs, Brighton	149.50	''	29/02/00
Mr John Dakis, 48 Middle Crs, Brighton	149.50	''	24/07/00
Mr John Robert Dale, 78 Treehaven Way, Maleny, Qld	104.00	''	24/07/00
Mr John Robert Dale, 78 Treehaven Way, Maleny, Qld	104.00	''	29/02/00
Mr Alberto D'Andrea, 18 Rokewood Ave, Belair, SA	174.74	''	24/07/00
Mr John Charles Death, 31 Charnley Street, Toowoomba, Qld	108.27	''	''
Mr John Charles Death, 31 Charnley Street, Toowoomba, Qld	108.27	''	29/02/00
Mrs Kathleen Josephine Delahunty, Bundella Station, Hughenden, Qld	452.57	''	24/07/00
Mr John Langworthy Dewar, 3/17 Uplands Place, Burnie, Tas.	209.70	''	''
Mr Ronald Dewson, PO Box 138, Lake Grace, WA	145.17	''	''
Mr Jesus Gutierrez Diaz, 4 Ballandella Rd, Toongabbie, NSW	111.90	''	''
Mr Brett Thomas Dibbin, 298 Vanlebup Road, Vanlebup, WA	116.84	''	29/02/00
Mr Gerald Harry Dorset, 64 Asling Street, Brighton Dottie Pty Ltd, 69 Tamarind Drive, Coachwood Park, Unanderna, NSW	109.04	''	24/07/00
Mr Neil Stuart Dowell, PO Box 1746, Katherine, NT	128.07	''	''
Mr Neil Stuart Dowell, PO Box 1746, Katherine, NT	143.60	''	29/02/00
Mr Neil Stuart Dowell, PO Box 1746, Katherine, NT	143.60	''	24/07/00
Mrs Dianne Barbara Dowling, 90 Atkinson St, Templestowe	132.66	''	29/02/00
Mrs Dianne Barbara Dowling, 90 Atkinson St, Templestowe	132.66	''	24/07/00
Mr Guy Germain Duval, 10/29 Hill Street, Perth, WA	112.91	''	29/02/00
G. Dwyer & N. Clark Lane Neave Ronaldson, Box 13149, Christchurch	247.25	''	24/07/00
Mr John Stanley Dwyer, Lot 1757, Grevillea Avenue, Kununurra, WA	101.57	''	''



Mr John Stanley Dwyer, Lot 1757, Grevillea Avenue, Kununurra, WA	101.57	”	29/02/00
Mr Robert Anthony Eastham, 48 Parkwood Way, Traralgon	124.25	”	24/07/00
Mr Robert Anthony Eastham, 48 Parkwood Way, Traralgon	124.25	”	29/02/00
EG Enterprises Pty Ltd, PO Box R20, Royal Exchange PO, Sydney, NSW	112.50	”	”
Mr Craig Elliott, 20 Howitt Street, Glen Iris	362.70	”	24/07/00
Mr Gregory Bruce Ernst, 152 Harrow Rd, Glenfield, NSW	103.14	”	”
Eroleeso Pty Ltd, 18/7 Anella Ave, Castle Hill, NSW	598.55	”	”
Esange Holdings Pty Ltd, 562 Little Bourke St, Melbourne	815.45	”	”
Esange Holdings Pty Ltd, 562 Little Bourke St, Melbourne	815.45	”	29/02/00
Estate Late Minnie Caroline Fahrenbach, Homebush Road, MSF 60, Mackay, Qld	159.43	”	”
Fair-Trade Pty Ltd, “Staff Super Fund A/C”, C/- Lal Pardasani & Assoc, 1st Floor 726 High Street Armadale	106.34	”	24/07/00
Estate Late Desmond Martin Falkenberg, C/- Caravan Park, Nuriootpa, SA	185.26	”	29/02/00
Miss Jacqueline Fallon, 51B Williton Rd, Karrinyup, WA	128.53	”	24/07/00
Miss Jacqueline Fallon, 51B Williton Rd, Karrinyup, WA	128.53	”	29/02/00
Mr Maxwell Graham Fimmell, Buchanan Road, Mount Gambier, SA	132.39	”	24/07/00
Mr Maxwell Graham Fimmell, Buchanan Road, Mount Gambier, SA	132.39	”	29/02/00
First Dental Company Pty Ltd, 77 Kennedy Street, Hamilton	104.58	”	”
First Dental Company Pty Ltd, 77 Kennedy Street, Hamilton	104.58	”	24/07/00
Mr Steven Fong, 32 Rathowen Parade, Killarney Heights, NSW	128.93	”	29/02/00
Mr Glenn Wayne Ford, 18 Fraser Road, Killcare, NSW	136.44	”	24/07/00
Mr Glenn Wayne Ford, 18 Fraser Road, Killcare, NSW	136.44	”	29/02/00
Mr John Paul Formosa, 19 Francis St, Gwynneville, NSW	107.78	”	24/07/00
Mr John Paul Formosa, 19 Francis St, Gwynneville, NSW	107.78	”	29/02/00
Ms Wendy Janine Frere, 7/6 John Street, Waverley, NSW	144.99	”	24/07/00
Mr Dragoljub Gacesa, Flat 1, 9–15 Hume Street, Wollstonecraft, NSW	119.39	”	29/02/00
Mr Dragoljub Gacesa, Flat 1, 9–15 Hume Street, Wollstonecraft, NSW	119.39	”	24/07/00
Mr Russell Wayne Gardener, 45 Power Street, Wavell Heights, Qld	146.30	”	”
Mr Ronald Gordon Garlick, 324 Seven Hills Road, Kings Langley, NSW	113.31	”	29/02/00
Mr Ronald Gordon Garlick, 324 Seven Hills Road, Kings Langley, NSW	113.31	”	24/07/00
Mrs Dorothy Margaret Gategood, 34 Bellevue Crs, Terrigal, NSW	169.97	”	29/02/00
Mrs Dorothy Margaret Gategood, 34 Bellevue Crs, Terrigal, NSW	169.97	”	24/07/00
Mr Robert Theodore Gauld, 19 Rochester Tce, Kelvin Grove, Qld	526.18	”	”
Mr Robert Theodore Gauld, 19 Rochester Tce, Kelvin Grove, Qld	526.18	”	29/02/00

Mr Gerrett Robert Gourley & Ms Susan Therese Willis, "G. R. Gourley Super Fund A/C", Suite 2, Typ Harbourside, Merewether Street, Newcastle, NSW	116.84	"	24/07/00
Mr Norman William Grant, 8 Sassafras Street, The Gap, Qld	126.81	"	29/02/00
Mr Simon Moore Greenaway, C/- JB Were Sydney, GPO Box 5264, Sydney, NSW	272.00	"	"
Mr Herbert John Guest, 35 Gilda Drv, Narara, NSW	113.22	"	24/07/00
Mr Herbert John Guest, 35 Gilda Drv, Narara, NSW	113.22	"	29/02/00
Miss Maria Barbara Guthrie, 6 Feeley Close, Brinsmead Glen, Cairns, Qld	107.73	"	29/02/00
Hon Kenneth Nigel Hampton, Chief Justices Chambers, PO Box 11, Nuku'alofa, Tonga 78	262.99	"	"
Hon Kenneth Nigel Hampton, Chief Justices Chambers, PO Box 11, Nuku'alofa, Tonga 78	262.99	"	24/07/00
Mr Alexander Ronald Hancock, 4 Woodland Loop, Edgewater, WA	155.21	"	"
Mr Alexander Ronald Hancock, 4 Woodland Loop, Edgewater, WA	155.21	"	29/02/00
Mr Richard Geoffrey Hancock, 221 Carmody Road, St Lucia, Qld	181.18	"	"
Mr Richard Geoffrey Hancock, 221 Carmody Road, St Lucia, Qld	181.18	"	24/07/00
Mr Adrian Thomas Hansberry, 2 Boffa St, Goodwood, SA	173.25	"	29/02/00
Miss Maree Cathryn Harcourt, C/- 19 High St, Trentham	145.10	"	"
Miss Maree Cathryn Harcourt, C/- 19 High St, Trentham	145.10	"	24/07/00
Mrs Rose Harrison, 7/153 Kooyong Road, Toorak	172.13	"	"
Mr Kevin John Harvey, 44 Alexander Avenue, Kiama Downs, NSW	124.98	"	24/07/00
Mr Neil Alexander Harvey, 311 Peasest Edge Hill, Cairns, Qld	114.57	"	29/02/00
Miss Betty Claire Hauser, C/- Messrs Rigby Cooke, Attention Stuart Morgan, PO Box 182, Malvern	126.32	"	"
Miss Betty Claire Hauser, C/- Messrs Rigby Cooke, Attention Stuart Morgan, PO Box 182, Malvern	126.32	"	24/07/00
Mr Brian Andrew Hennessy, C/- Railway Quarters, Alpha, Qld	101.89	"	29/02/00
Mr Brian Andrew Hennessy, C/- Railway Quarters, Alpha, Qld	101.89	"	24/07/00
Mr D. T. Herbert Carroboblin, Bedgerebong, NSW	103.01	"	29/02/00
Mr D. T. Herbert Carroboblin, Bedgerebong, NSW	103.01	"	24/07/00
Mr Brian Charles Herbert, 2 Cowley St, Tocumwal, NSW	131.90	"	"
Mr Peter Gilbert Heron, PO Box 427, Labrador, Qld	152.06	"	29/02/00
Mr John Anthony Hewett, 4 Wayeela Pl, City Beach, WA	146.48	"	"
Mr Michael Hirons & Mrs Bronwyn Hirons, "Hirons Super Fund A/C", 5 Parkside Street, Malvern	148.50	"	24/07/00
Mr Allan Henry House, 17 Kenmare Ave, Berkeley Vale, NSW	171.07	"	"
Mr Allan Henry House, 17 Kenmare Ave, Berkeley Vale, NSW	171.07	"	29/02/00
Estate Late James Thomas Howard, C/- 12 Belmore Street, Rozelle, NSW	179.33	"	24/07/00
Mr Mark Leslie Howson, 10 Jabberup Crs, Newman, WA	112.68	"	"
Mr Peter Arthur Leslie Howson, 6 Tjilla St, Newman, WA	162.27	"	29/02/00
Mr Peter Arthur Leslie Howson, 6 Tjilla St, Newman, WA	162.27	"	24/07/00
Mr Charles Malcolm Alexander Hudson, 2/28 Tivoli Pl, South Yarra	106.97	"	29/02/00
Impolo Pty Ltd, 15/33 College St, Gladesville, NSW	151.56	"	24/07/00
Impolo Pty Ltd, 15/33 College St, Gladesville, NSW	151.56	"	29/02/00

Mr David Philip Ingham, 11 Korrela Street, Mullaloo, WA	149.58	''	''
Mr Ross Morgan Ingram, 10 Wills Street, Balwyn	135.00	''	''
Mr Ross Morgan Ingram, 10 Wills Street, Balwyn	135.00	''	24/07/00
Mr Martin Sidney Johnson, 7 Coronet St, Woodcroft, SA	100.58	''	''
Mr Barry Johnston, 5 Baudin Street, Forrest, ACT	362.70	''	29/02/00
Mr Barry Johnston, 5 Baudin Street, Forrest, ACT	362.70	''	24/07/00
Mr Gordon Berkeley H. Jones, 135 Harbord Road, Harbord, NSW	170.21	''	29/02/00
Mr Gordon Berkeley H. Jones, 135 Harbord Road, Harbord, NSW	170.21	''	24/07/00
Mr Rodney Clifford Jones, Redside Melton, Mowbray, Tas.	100.26	''	29/02/00
Mr Vincent A. Joseph, 19 Furneaux Street, Manuka ,ACT	487.49	''	24/07/00
Mr Muhamad Karamah, Unit 2, 20 Sergison Circuit, Rapid Creek, NT	108.80	''	29/02/00
Mr Sam Katz, 63/2 Francis Street, Artarmon, NSW	106.92	''	''
Mr Sam Katz, 63/2 Francis Street, Artarmon, NSW	106.92	''	24/07/00
Mr Lex Keam, 22 Mount Pleasant Road, Gympie, Qld	124.74	''	''
Mr Lex Keam, 22 Mount Pleasant Road, Gympie, Qld	124.74	''	29/02/00
Ms Rebecca Keene, "Oban Superannuation Fund A/C", 15 Toorak Road, South Yarra	180.00	''	24/07/00
Mrs Pamela Kay Kelly, PO Box 429, Loxton, SA	265.05	''	29/02/00
Mrs Pamela Kay Kelly, PO Box 429, Loxton, SA	265.05	''	24/07/00
Mr Gordon Kerr, Unit 603, 199-223 Pyrmont Street, Pyrmont, NSW	275.13	''	29/02/00
Dr Rao Irshad Mohammad Khan, 42 Hill Street, Cabramatta, NSW	191.46	''	24/07/00
Mrs Zia-Ul Qamar Khan, 42 Hill Street, Cabramatta, NSW	191.46	''	''
Mr Philip Boun Houa Khong, 3593 Lariat Lane, Rolling Hills Estates, CA, USA	112.40	''	''
Mr Ross Gregory Kidd, 26 Mt Pleasant Rd, Gympie, Qld	127.31	''	''
Dr Simon Anthony Sleigh Knowles, Department of Pathology, Royal Devon & Exeter Hospital, Barrack Road, Exeter EX2 5DW United Kingdom	109.56	''	29/02/00
Mr Leslie Kohn, 1/9 Claire Street, Bentleigh	120.83	''	24/07/00
Mr David Leng Kow, 31 Cocoparra Crescent, Taylors Lakes	217.60	''	29/02/00
Ms Leony Kowald, 16 Harbison Crescent, Wanniasa, ACT	144.99	''	''
Dr Clive Harold Lacey, 12-119 South Terrace, Fremantle, WA	117.68	''	24/07/00
Mr Rodney Keith Lambert, 17 Kaeser Road, Pioneer, Mount Isa, Qld	128.30	''	29/02/00
Mr Rodney Keith Lambert, 17 Kaeser Road, Pioneer, Mount Isa, Qld	128.30	''	24/07/00
Mr Peter Langeveld, 22 Kennington Park Drive, Endeavour Hills	186.03	''	29/02/00
Mr Peter Langeveld, 22 Kennington Park Drive, Endeavour Hills	186.03	''	24/07/00
Mrs Muriel Lankester, 2 McKenna Glen, Mt Claremont, WA	112.14	''	29/02/00
Mr Jeremy Kheong Thye Lau, 10 Turtle Rd, Caringbah, NSW	105.08	''	''
Mr Max Leaford, 4 Avenell Ave, Christies Beach, SA	119.79	''	24/07/00
Learly Pty Ltd, PO Box 238, St Ives, NSW	308.30	''	29/02/00
Lebola Pty Ltd, "Hyc Superannuation Fund A/C", 1st Floor, 1 Park Road, Hurstville, NSW	145.10	''	24/07/00

Mr Charles William Lees, Box 5, Laburnum LPO	168.17	''	29/02/00
Mr Thomas Rex Little, PO Box 46, Nunawading	178.34	''	''
Mr Brett Bing Liu & Mr Zinan Liu, 1/11 Monomeath Avenue, Toorak	163.20	''	24/07/00
Dr Peter Charles Lugg, 26 Yarra Street, Hawthorn	130.95	''	29/02/00
Ms Elizabeth Evelyn MacDonald, 29 Osborne Parade Claremont WA	450.00	''	''
Ms Elizabeth Evelyn MacDonald, 29 Osborne Parade Claremont WA	450.00	''	24/07/00
Mr Robert John MacLaine, PO Box 29, Strahan, Tas.	145.80	''	29/02/00
Mr Donald Ian MacLeod, 13 Braid Hill Rd, MacLeod	252.18	''	24/07/00
Mr Donald Ian MacLeod, 13 Braid Hill Rd, MacLeod	252.18	''	29/02/00
Hon David Kingsley Malcolm, Chief Justice's Chambers, Supreme Court, Perth, WA	226.37	''	29/02/00
Ashok Malhutra, PO Box 6341, East Perth, WA	108.80	''	24/07/00
Ashok Malhutra, PO Box 6341, East Perth, WA	108.80	''	29/02/00
Mr Graeme Lloyd Mallet, PO Box 35, Nambour, Qld	100.62	''	24/07/00
Mr Brian Desmond Malt, 38 Albany Ave, Currumbin, Qld	131.67	''	29/02/00
Mr Brian Desmond Malt, 38 Albany Ave, Currumbin, Qld	131.67	''	24/07/00
Mr Gavin Man, 54 Kennedy Street, Kingsford, NSW	270.00	''	''
Ms Christine Mansour, 31 Avon Court, Albany Creek, Qld	126.95	''	29/02/00
Ms Christine Mansour, 31 Avon Court, Albany Creek, Qld	126.95	''	24/07/00
Mr Peter Marenos, 4 Erang Cl, Greensborough	102.25	''	''
Mrs Hazle Ann Marland, Mt Wallaby, Gin Gin, Qld	117.81	''	29/02/00
Mr Raymond Douglas Mather, 30/108 Reserve Road, Artarmon, NSW	107.10	''	24/07/00
Mr Raymond Douglas Mather, 30/108 Reserve Road, Artarmon, NSW	107.10	''	29/02/00
Mr John Alexander Maxwell, 7 Malu St, Middle Park, Qld	101.16	''	24/07/00
Mr Brian William May, RMB 314, Creswick-Smeaton Road, Smeaton	105.44	''	''
Estate Late Carmine Mazzarelli, C/- T K Delaney & Co, PO Box 455, Clayfield, Qld	118.98	''	24/07/00
Mr James Martin McDonald, 5 Leonora Ave, St Ives, NSW	155.16	''	29/02/00
Lynley Joy McDonald, 95 Thirteenth Avenue, Tauranga 3001	108.80	''	''
Lynley Joy McDonald, 95 Thirteenth Avenue, Tauranga 3001	108.80	''	24/07/00
Mr Alan John McLean, 1/90 Hillsborough Road, "Spring Ridge", Hillsborough Via Maitland, NSW	111.38	''	''
Mr Graham McLune & Mrs Wendy McLune, 5 Brandy Crt, Calamvale, Qld	115.77	''	29/02/00
Mr John Dennis Milne & Mrs Rosemarie Milne, 52 Edina Road, Ferntree Gully	125.64	''	''
Mr John Lockwood Morrison & Mr Robert Lewis Milne & Mr Leonard Frederick Barlow, Messrs R. Milne, L, Barlow, 32-34 Burwood Road, Hawthorn	542.48	''	24/07/00
Mr John Lockwood Morrison & Mr Robert Lewis Milne & Mr Leonard Frederick Barlow, Messrs R. Milne, L, Barlow, 32-34 Burwood Road, Hawthorn	542.48	''	29/02/00
Mr Giovanni Morzone, PO Box 1346, Ingham, Qld	197.01	''	24/07/00
Sheron Mougrabi, 2 Moray Court, Banowa, Qld	225.00	''	''
Sheron Mougrabi, 2 Moray Court, Banowa, Qld	225.00	''	29/02/00
Ms Gloria Mary Moyse, 120 Glengarry Drv, Duncraig, WA	112.46	''	''
Ms Gloria Mary Moyse, 120 Glengarry Drv, Duncraig, WA	112.46	''	24/07/00

The Munchkin Gallery Pty Ltd, C/-Mr R. A. Doyle, 24 Grosvenor Road, Terrigal, NSW	198.72	''	29/02/00
Mr Peter Nash & Mr David Nash, 7 Barbican Ct, Rowville	147.26	''	24/07/00
Mr Phillip William Nash, 7 Palm Vista Drive, Safety Beach	107.60	''	''
Mr Trevor William Needham, Mr G. C. Clegg, 88 Frederick Street, Northgate Qld	136.94	''	''
Mrs Marie Jean Newbury, Iolanthe Garah, NSW	309.83	''	29/02/00
Mrs Marie Jean Newbury, Iolanthe Garah, NSW	309.83	''	24/07/00
Mr Vincent Kf Ng, PO Box 376, Rockdale, NSW	106.34	''	''
Mr Ronald Francis Nissen, 30 Adelaide St, Clontarf, NSW	135.68	''	''
Mr Ronald Francis Nissen, 30 Adelaide St, Clontarf, NSW	135.68	''	29/02/00
Mr Allan Ray Noble, Unit 2/51 Trafalgar St, Glenfield, NSW	148.68	''	''
Mr Francis J. Noonan, 47 Saltley Street, South Kingsville	104.85	''	''
Mr Francis J. Noonan, 47 Saltley Street, South Kingsville	104.85	''	24/07/00
Dr John Francis O'Mahony, 60 Excelsior Street, Shenton Park, WA	427.41	''	''
Ms Oi Chu Ong, PO Box 1691, Woden, ACT	138.96	''	29/02/00
Ms Oi Chu Ong, PO Box 1691, Woden, ACT	138.96	''	24/07/00
Mr Nedeljko Oreb, 1/369 King Street, Newtown, NSW	132.44	''	''
Mr Brett Raymond O'Riley, PO Box 172, North Sydney, NSW	147.69	''	''
Mr Brett Raymond O'Riley, PO Box 172, North Sydney, NSW	147.69	''	29/02/00
Mr Richard Pace, 7 Maple Crs, Churchill	133.70	''	24/07/00
Manash Patel, Unit 5, 47-49 Little Palmerston Street, Carlton	120.83	''	29/02/00
Manash Patel, Unit 5, 47-49 Little Palmerston Street, Carlton	120.83	''	24/07/00
Mr Gerry Pennisi, 8 Turner Avenue, New Farm, Qld	121.50	''	''
Dr Dhammika Milani Perera, 28 Oakover Street, East Fremantle, WA	138.69	''	''
Mr Andreas Urs Pfluger & Mrs Carmen Maria Blatter, 252 Glenmore Road, Paddington NSW	225.00	''	29/02/00
Mr James Lee Phenix & Mrs Bulian Phenix, 8 Lorong 16/9A 46350 Petaling Jaya Selangor, Malaysia	240.77	''	24/07/00
Ms Catherine Helen Powell, PO Box 2236, North Brighton	193.32	''	29/02/00
Profit State Pty Ltd, 1 Princess Street, Kew	118.55	''	''
Mr Ronald Arthur Prowse, 8 Trevalsa Place, Burraneer, NSW	193.32	''	24/07/00
Mr Ronald Arthur Prowse, 8 Trevalsa Place, Burraneer, NSW	193.32	''	29/02/00
Mr Michael John Pryce, 128 Pacific Rd, Palm Beach, NSW	411.71	''	''
Mr Michael John Pryce, 128 Pacific Rd, Palm Beach, NSW	411.71	''	24/07/00
Mr Otto Antonius Raats, 16 Durban Place, Warnbro, WA	126.45	''	''
Mr Otto Antonius Raats, 16 Durban Place, Warnbro, WA	126.45	''	29/02/00
Mr Alexander Rae, 8 Davison Crs, Ferntree Gully	174.60	''	24/07/00
Mr Alexander Rae, 8 Davison Crs, Ferntree Gully	174.60	''	29/02/00
Really Big Tomatoes Pty Ltd, 91 Simpson Street, East Melbourne	180.00	''	24/07/00
Really Big Tomatoes Pty Ltd, 91 Simpson Street, East Melbourne	180.00	''	29/02/00
Mr Phillip John Reeves, 6 Hawthorne St, Sth Grafton, NSW	112.68	''	''
Mr Phillip John Reeves, 6 Hawthorne St, Sth Grafton, NSW	112.68	''	24/07/00
Mrs Yvonne Gwen Rennie, 20 Huron Ave, Wagga Wagga, NSW	107.15	''	29/02/00
Mrs Yvonne Gwen Rennie, 20 Huron Ave, Wagga Wagga, NSW	107.15	''	24/07/00

Mr Lloyd Raymond Reynolds, 122 Belgrave-Hallam Road, Belgrave	140.81	''	''
Mr Kevin Garry Richardson, 121A Lookout Road, New Lambton, NSW	149.24	''	29/02/00
Mr Kevin Garry Richardson, 121A Lookout Road, New Lambton, NSW	149.24	''	24/07/00
Mast Harvinder Singh Rikhraj, 9 Poplar St, Willetton, WA	131.67	''	''
J. Robertson & R. Robertson, 4 Burchill St, Loganholme, Qld	100.36	''	29/02/00
J. Robertson & R. Robertson, 4 Burchill St, Loganholme, Qld	100.36	''	24/07/00
Dr Raymond Joseph Rodgers, Dept of Medicine, Flinders University, Bedford Park, SA	157.81	''	''
Mr Peter Norman Roehr, PO Box 55, Koonunga Hill, Via Kapunda, SA	306.51	''	29/02/00
Mr Vincent Rogers, 9 Eaglet Crt, Mill Park	123.12	''	24/07/00
Mrs Anna Maria Rosenwax, 30 Portland Road, Dover Heights NSW	104.49	''	29/02/00
Mr Giuseppe Rugari, 21 Willcox Avenue, Prospect, SA	120.51	''	''
Mr Oliver Patrick Ryan Brawijaya, Vi No. 2 Jakarta Kebayoran Baru 8273, Indonesia	101.69	''	''
Mr Oliver Patrick Ryan Brawijaya, Vi No. 2 Jakarta Kebayoran Baru 8273, Indonesia	101.69	''	24/07/00
Samtrad Holdings Pty Limited, 156 Victoria Road, Bellevue Hill, NSW	183.38	''	29/02/00
Estate Late Margaret Jane Sands, C/- Mr R. Reading, 224 Annangrove Road, Annangrove, NSW	107.60	''	24/07/00
Estate Late Margaret Jane Sands, C/- Mr R. Reading, 224 Annangrove Road, Annangrove, NSW	107.60	''	29/02/00
Mr Peter Edward Schmalz, PO Box 264, The Junction, NSW	108.54	''	24/07/00
Mr James Lachlan Scott, 3 Elizabeth Street, Elsternwick	124.07	''	''
Mr Bruce Andrew Shallcross, Unit 4/27 Lyne Road, Cheltenham, NSW	192.18	''	''
Ying Lung Shen, 85-267 Castlereagh Street, Sydney, NSW	290.03	''	29/02/00
Ying Lung Shen, 85-267 Castlereagh Street, Sydney, NSW	290.03	''	24/07/00
Mrs Elizabeth Isabella Shephard, 5 Salinas Pl, Bracken Ridge, Qld	457.74	''	24/07/00
Sherlock Glen Pty Ltd, 359 High Street, Preston	114.33	''	29/02/00
Sherlock Glen Pty Ltd, 359 High Street, Preston	114.33	''	24/07/00
Mr Andy Guo Qin Shi & Mrs Xiao Hong He, 3 Narinna Avenue, Cumberland Park, SA	169.16	''	29/02/00
Mr Frank Sibio, PO Box 460, Tatura	123.98	''	24/07/00
Mr Frank Sibio, PO Box 460, Tatura	123.98	''	29/02/00
Mr Con Skarparis, 2 Freeman Avenue, Oatley, NSW	106.34	''	24/07/00
Skylake Pty Ltd, (Goodwin Property A/C), 233 Kelvin Grove, Qld	821.79	''	''
Mr Brian Thomas Wavell-Smith, 25 Fleetway Street, Morningside, Qld	110.03	''	29/02/00
Mr Brian William Smith, 13 Duncan Rd, Dry Creek, SA	352.49	''	24/07/00
Mrs Elizabeth Ann Wavell-Smith, 25 Fleetway Street, Morningside, Qld	110.03	''	29/02/00
Miss Jan Maree Smith, 3/2 Sandford Street, St Lucia, Qld	217.78	''	''
Miss Jan Maree Smith, 3/2 Sandford Street, St Lucia, Qld	217.78	''	24/07/00
Miss Sigrid Johanna Stahlschmid, 64 Dent St, Glen Iris	174.15	''	''
Ms Jacqueline Starr, 3/20 Prahran Grove, Elsternwick	166.77	''	29/02/00

Mr Ray Gordon Stevens, PO Box 28, Kenilworth, Qld	178.02	''	24/07/00
Mr Dudley Wilson Stimpson, PO Box 1654, Toowoomba, Qld	120.60	''	''
Uni of Sydney/Sta, C/o 50 Park Road, Hunters Hill, NSW	300.04	''	''
Uni of Sydney/Sta, C/o 50 Park Road, Hunters Hill, NSW	300.04	''	29/02/00
Mr Anthony Sykes Bloomsbury, PO Box 61, The Patch	179.78	''	24/07/00
Dr William Kwok Hung Tam, 62 Highgate Street, Strathfield, NSW	160.02	''	29/02/00
Mr Trevor Francis Tanner, 21 William St, Bunbury, WA	104.99	''	''
Mr Mark John Tink, 11 Edwards Cres, Waikerie, SA	100.49	''	24/07/00
Mr David Rodney Tolliday, 16 Schoolhall Street, Oakleigh	135.00	''	''
Mr David Rodney Tolliday, 16 Schoolhall Street, Oakleigh	135.00	''	29/02/00
Mrs Jillian Mary Tutty, 76 Temple Crescent, Timaru 8601	100.23	''	24/07/00
Mr Paul Joseph Van Bladel, PO Box 1648, Coffs Harbour, NSW	257.67	''	''
Dr Girolamo Vinci, 472 Henley Beach Rd, Lockleys, SA	230.40	''	29/02/00
Estate Late Mary Edna Vine, C/- Michael A. Smith, PO Box 531, Surfers Paradise, Qld	104.67	''	24/07/00
Dr Joseph Anthony Virgona, 16 Buckland Ave, Newtown	444.11	''	''
Mr Jeffrey James Wake, 181 South Avenue, Weston, MA 02493 USA	108.63	''	29/02/00
Mr Jeffrey James Wake, 181 South Avenue, Weston, MA 02493 USA	108.63	''	24/07/00
Western Investments (1984) P/L, Cnr Cowper & Hopkins Street, Footscray	287.55	''	''
Western Investments (1984) P/L, Cnr Cowper & Hopkins Street, Footscray	287.55	''	29/02/00
White Ant Industries Pty Ltd, 18 Kelvin Grove, Prahran East	135.00	''	''
Estate Late Joyce Marguerita White, C/- Van Lierop & Co, 180 Main Street, Croydon	157.59	''	24/07/00
Mrs Heather May Whitson, PO Box 97, Mackay, Qld	269.31	''	''
Mrs Heather May Whitson, PO Box 97, Mackay, Qld	269.31	''	29/02/00
Mr Neil J. Whitson, PO Box 97, Mackay, Qld	135.31	''	24/07/00
Mr Neil J. Whitson, PO Box 97, Mackay, Qld	135.31	''	29/02/00
Mr William Noel Wilde, 62 Darling Crs, Mt Isa, Qld	142.83	''	''
Mr Doug Willett, PO Box 397, Hurstbridge	143.15	''	24/07/00
Williamson Administration Pty Limited "Williamson Superfund A/C", 519 Fig Tree Pocket Road, Fig Tree Pocket, Qld	241.61	''	29/02/00
Mr Robert James Wilmot, PO Box 1563, Mount Isa, Qld	155.93	''	''
Mr Robert James Wilmot, PO Box 1563, Mount Isa, Qld	155.93	''	24/07/00
Dr Nasreen Taj Wilson, 54 Grand Junction Road, Rosewater, SA	104.00	''	29/02/00
Dr Nasreen Taj Wilson, 54 Grand Junction Road, Rosewater, SA	104.00	''	24/07/00
Mr Robert John Wilson, Box 95, Glossop, SA	114.15	''	29/02/00
Mr Bevan Winn, 5 Thomson Street, Brighton	253.23	''	24/07/00
Mr Bevan Winn, 5 Thomson Street, Brighton	253.23	''	29/02/00
Miss Judith Lorraine Wisbey, 23 Clarke St, Thomastown	130.05	''	''
Mr Alan Keith Wong, 863 Waverley Rd, Glen Waverley	164.01	''	29/02/00
Mr Alan Keith Wong, 863 Waverley Rd, Glen Waverley	164.01	''	24/07/00
Dr Wilson Godfrey James Wylie, 418 Williams Street, Broken Hill, NSW	450.00	''	''

Mr William Kam Seng Yeong, 12/9a Cook St, Glebe, NSW	125.15	”	29/02/00
Mr William Kam Seng Yeong, 12/9a Cook St, Glebe, NSW	125.15	”	24/07/00
Mrs Anne Caroline Zeeman, 18 Jabez Crescent, Lenah Valley, Tas.	141.46	”	”
Mrs Anne Caroline Zeeman, 18 Jabez Crescent, Lenah Valley, Tas.	141.46	”	29/02/00

02078

CONTACT: ELAINE V. HARE, PHONE: (03) 9611 5714.

**Unclaimed Moneys Act 1962**

Register of Unclaimed Moneys held by the —

<i>Name of Owner on Books and Last Known Address</i>	<i>Total Amount Due to Owner</i>	<i>Description Of Unclaimed Money</i>	<i>Date when Amount first became Payable</i>
BANYULE CITY COUNCIL			
	\$		
1st Ivanhoe Sea Scout Group	200.00	Cheque	03/06/99
Sophie's Fruit Market	122.35	”	14/07/99
Mr A. Williams	116.55	”	29/10/00

02155

CONTACT: ROBERT FARALLA, PHONE: (03) 9490 4283.

**Unclaimed Moneys Act 1962**

Register of Unclaimed Moneys held by the —

<i>Name of Owner on Books and Last Known Address</i>	<i>Total Amount Due to Owner</i>	<i>Description Of Unclaimed Money</i>	<i>Date when Amount first became Payable</i>
BONLAC FOODS LIMITED			
	\$		
Mrs Shirley Jean Cameron, “Pension Fund A/C”, Level 15, 309 Kent Street, Sydney, NSW	1,900.00	Cheque	31/12/00
Robert Stewart Hollonds & Ronald Keith White & Reginald Ross Hollonds, “Jesse Hollond Mem Fund A/C”, 27 Glenbourn Drive, Tawonga South	237.50	”	”
John Mullins & Kathleen Mullins, “H. K. B. M. J. E. Mullins A/C” 1367 Pepper Tree Lane, Kyabram	313.50	”	”



Mr Herbert George Nicholls, C/- 17 Copperleaf Place, Cherrybrook, NSW	237.50	”	”
Ms Jill Robin Wilson, C/- Macquarie Equities Limited, PO Box H68, Australia Square, NSW	950.00	”	”

02079

CONTACT: ELAINE V. HARE, PHONE: (03) 9611 5714.

**Unclaimed Moneys Act 1962**

Register of Unclaimed Moneys held by the —

<i>Name of Owner on Books and Last Known Address</i>	<i>Total Amount Due to Owner</i>	<i>Description Of Unclaimed Money</i>	<i>Date when Amount first became Payable</i>
<b>CHALLENGER PROPERTY INCOME TRUST</b>			
\$			
Accbell Nominees Pty Ltd, Level 33, 101 Collins Street, Melbourne	1,927.98	Cheque	25/08/00
Kingsley Andrew, C/- Barry Phillis & Assoc P/L, 45 Grenfell Street, Adelaide SA	247.50	”	25/02/00
BB Nominees Pty Ltd, “Client Account”, Level 33, 101 Collins Street, Melbourne	1,707.96	”	25/08/00
Mr Lisle Darcy Carr & Mrs Suzanne Carr, “LD & S Carr Super Fund A/C”, Wendouree	254.90	”	25/02/00
Mr Lisle Darcy Carr & Mrs Suzanne Carr, “LD & S Carr Super Fund A/C”, Wendouree	309.00	”	25/08/00
Edsgear Pty Limited, Level 23, 580 George Street, Sydney, NSW	4,950.00	”	25/02/00
Mr Gareth Michael Emery, 16 Mirams Street, Ascot Vale	180.00	”	25/08/00
Mr Morris William Guest, 36/86 Burnley Street, Richmond	126.00	”	”
Mr Morris William Guest, 36/86 Burnley Street, Richmond	103.95	”	25/02/00
Hickory Grove Pty Ltd “Superannuation Fund A/C”, Level 2, 150 Albert Road, South Melbourne	300.00	”	25/08/00
Hickory Grove Pty Ltd “Superannuation Fund A/C”, Level 2, 150 Albert Road, South Melbourne	247.50	”	25/02/00
Mr David Alfred Hopkins & Mr Ewen McMillan, 65 Coppards Road, Newcomb	123.75	”	”
Mr David Alfred Hopkins & Mr Ewen McMillan “Staff Superannuation A/C”, 65 Coppards Road, Newcomb	371.25	”	”
J. F. Clark Investments Pty Ltd, 507 Royal Parade, Parkville	3,960.00	”	”
Mrs Pauline Kirwan & Mr Peter Stanley, “Pat Kirwan Super Fund A/C”, 103 Birchwood Avenue, Woodlands, WA	381.15	”	”
Ms Eva Wai-Man Lee, 42 Forestway, Frenchs Forest, NSW	126.00	”	25/08/00
Ms Judith Ellen Mellers, 2/104 Herring Road, North Ryde, NSW	600.00	”	”

Ms Judith Ellen Mellers, 2/104 Herring Road, North Ryde, NSW	495.00	”	25/02/00
National Australia Trustees Limited, “Nrlpt A/C”, GPO Box 247B, Melbourne	2,293.63	”	”
Netshare Nominees Pty Ltd, “Reconciliation A/C”, PO Box 7428, Cloisters Square, WA	3,074.34	”	25/08/00
Allan Normington, “Windriver Super Fund A/C”, 107 Milson Road, Cremorne Point, NSW	382.65	”	25/02/00
Presvoile Pty Limited, 130 Wallis Ave, Strathfield, NSW	144.00	”	25/08/00
Rbf Services Pty Ltd, “Firth Account”, 102 New Street, Brighton	495.00	”	25/02/00
Mr Ken James Reynolds & Mrs Myra Reynolds, “Super Fund A/C”, 3/9 Blair Street, Bentleigh	288.00	”	25/08/00
Mr Ken James Reynolds & Mrs Myra Reynolds, “Super Fund A/C”, 3/9 Blair Street, Bentleigh	237.60	”	25/02/00
Ms Vicky Rumenos, 2/27 Enterprise Crescent, Malaga, WA	128.70	”	”
Ms Vicky Rumenos, 2/27 Enterprise Crescent, Malaga, WA	156.00	”	25/08/00
Mr Ken Swain, PO Box 809, Norfolk Island, NSW	495.00	”	”
Mr Ken Swain, PO Box 809, Norfolk Island, NSW	600.00	”	”
Thoughtful Nominees Pty Ltd, C/- D & D Tolhurst Ltd, GPO Box 1392M, Melbourne	1,068.00	”	”
Mr Kevin Wilson & Mrs Jola Wilson, 3245 Paradise Drive, Tiburon, California 94920-1214 USA	804.55	”	25/02/00

02081

CONTACT: ELAINE V. HARE, PHONE: (03) 9611 5714.

**Unclaimed Moneys Act 1962**

Register of Unclaimed Moneys held by the —

<i>Name of Owner on Books and Last Known Address</i>	<i>Total Amount Due to Owner</i>	<i>Description Of Unclaimed Money</i>	<i>Date when Amount first became Payable</i>
DIVERSIFIED UNITED INVESTMENT LTD			
\$			
Mr James Joseph Conroy, PO Box 101, Blayney, NSW	169.76	Cheque	09/10/00
Mr Paul Hodgson, “Informed Sources S/Fund A/C”, 42 Stonehaven Crescent, Deakin, ACT	112.50	”	14/04/00
Anthony Michael Sciuto, C/- Tower Trust Ltd, GPO Box 546, Adelaide, SA	314.06	”	09/10/00
Mr Edward William John Wickham, 55 Power Street, Hawthorn	375.00	”	”

02085

CONTACT: ELAINE V. HARE, PHONE: (03) 9611 5714.

**Unclaimed Moneys Act 1962**

Register of Unclaimed Moneys held by the —

<i>Name of Owner on Books and Last Known Address</i>	<i>Total Amount Due to Owner</i>	<i>Description Of Unclaimed Money</i>	<i>Date when Amount first became Payable</i>
<b>EAST AFRICAN COFFEE PLANTATIONS LIMITED</b>			
	\$		
Mrs Jean E. Boulton, Unit 4, 122 Atherton Road, Oakleigh	136.50	Cheque	19/05/00
Mr Norio Goto, PSC 473, Box 96, Fpo Ap 96349-0005 USA	173.25	"	"
M/s Hilda M Hall, Decd, C/- Mr W. J. Hall, 6 Electra Street, Williamstown	195.72	"	"
Estate Late Philip T. Le Couilliard, C/- Stephen Le Couilliard & Co Pty Ltd, PO Box 43, Narre Warren	147.00	"	"
Mr Glenister Douglas Liddell, 6 Guitau Street, Boroko, Papua New Guinea	105.00	"	"
Mrs Lynette Lawrence Lowry & Mr Ian Blair Lowry & Mrs Annette Mary Lawrence, Court 1A, The Avenue, East Malvern	420.00	"	"

02086

CONTACT: ELAINE V. HARE, PHONE: (03) 9611 5714.

**Unclaimed Moneys Act 1962**

Register of Unclaimed Moneys held by the —

<i>Name of Owner on Books and Last Known Address</i>	<i>Total Amount Due to Owner</i>	<i>Description Of Unclaimed Money</i>	<i>Date when Amount first became Payable</i>
<b>ENERGY DEVELOPMENTS LIMITED</b>			
	\$		
Vivien Margaret Caprioglio, 4 Stawell Street, Kew	128.75	Cheque	18/10/00
Mrs Rosemary Joan Christie, 24 Ronaki Road, Mission Bay, Auckland 1105, NZ	212.50	"	"
Graham Richard Etherington & Nolene Rose Etherington, 18 Longleaf Street, Frankston	240.00	"	10/04/00
Graham Richard Etherington & Nolene Rose Etherington, 18 Longleaf Street, Frankston	250.00	"	18/10/00
Mr Robert John Marshall, 5 Elmore St, Redbank Plains, Qld	125.00	"	"
Mr William Anthony Rogers & Mrs Valda Irene Rogers,			

1108 G 22 30 May 2002

Victoria Government Gazette

Unit 2, 24 Kathrina Street, Noosa Heads, Qld Mrs Natalie Therese Rosenbloom, C/- David Rosenbloom Wallara Asset Management, 1/175 Collins Street, Melbourne	100.83	”	”
Sered Pty Ltd, “Dreamtime Unit A/C”, C/- T. Sheldon, 85 Stewart Street, Paddington, NSW	161.33	”	10/04/00
Mr Mark Sereni, 38 Gooden Drive, Baulkham Hills, NSW	123.60	”	”
	120.63	”	”

02088

CONTACT: ELAINE V. HARE, PHONE: (03) 9611 5714.

---

### Unclaimed Moneys Act 1962

Register of Unclaimed Moneys held by the —

---

<i>Name of Owner on Books and Last Known Address</i>	<i>Total Amount Due to Owner</i>	<i>Description Of Unclaimed Money</i>	<i>Date when Amount first became Payable</i>
EQUITY TRUSTEES LIMITED			
\$			
Miss Susan Isabelle Deamer, 12 Boondah Place, Warrawee, NSW	111.09	Cheque	09/11/00
Mr Sydney Robinson Deamer, 87 Thornley Road, Fairfield West, NSW	111.09	”	”
Mr Christopher Matthew Lines, 20 Renown Avenue, Tranmere, SA	164.68	”	”
Mr Christopher Matthew Lines, 20 Renown Avenue, Tranmere, SA	100.24	”	18/04/00
Long Root Nursery Pty Ltd, “Holder Family A/C”, 2 Foster Road, Olinda	667.92	”	09/11/00
Mrs Judith Anthea Lonie, 17 Woodstock Street, Bondi Junction, NSW	400.66	”	”
Mr Ronald Campbell MacTaggart, 55 Wattle Valley Road, Canterbury	1,335.84	”	”
Dr Janice Catherine Smith, 8 St Vincent Place Albert Park	2,003.76	”	09/11/00
Mr Forster B. Weeks, PO Box 704, Suva, Fiji	406.56	”	18/04/00
Mr Forster B. Weeks, PO Box 704, Suva, Fiji	667.92	”	09/11/00

02089

CONTACT: ELAINE V. HARE, PHONE: (03) 9611 5714.

---

**Unclaimed Moneys Act 1962**

Register of Unclaimed Moneys held by the —

<i>Name of Owner on Books and Last Known Address</i>	<i>Total Amount Due to Owner</i>	<i>Description Of Unclaimed Money</i>	<i>Date when Amount first became Payable</i>
GANDEL RETAIL TRUST			
	\$		
Mr John Moir Alexander, 20 Seaview Street, Blairgowrie	442.90	Cheque	25/08/00
Mrs Martha Aspinall, Unit 39, 204 Jersey Road, Woollahra, NSW	126.00	"	24/02/00
Mrs Rosemary Anne Barr, 210 Williams Road, Toorak	179.22	"	25/08/00
Mr Glenn Bermingham, 6 Rowland Street, Mont Albert	430.00	"	"
Mr Glenn Bermingham, 6 Rowland Street, Mont Albert	420.00	"	24/02/00
Bogong Investments Pty Limited, "Superannuation A/C", Attn: Mr Russel Stevenson 29 The Parade, Tumbarumba, NSW	294.00	"	"
Mrs Beatrice Brock, 64 Springfield Road, Box Hill North	258.00	"	25/08/00
Mrs Hannah Christine Cameron, 15 Saunders Street, Swanbourne, WA	1,680.00	"	24/02/00
Mrs Sybil Clifford, Unit 150, Glenaeon Retirement Village, Glenaeon Avenue, Belrose, NSW	1,128.16	"	25/08/00
Mrs Sybil Clifford, Unit 150, Glenaeon Retirement Village, Glenaeon Avenue, Belrose, NSW	1,101.94	"	24/02/00
Mrs Jacqueline S. Czislowski, 1/6 Grange Road, Toorak	504.00	"	"
Mrs Jacqueline S. Czislowski, 1/6 Grange Road, Toorak	516.00	"	25/08/00
Mr Joseph Peter Divola, PO Box 14, Maryborough	135.14	"	"
Dr Brian Ashley Greed, PO Box 430, Benalla	462.00	"	24/02/00
Est Late Mary Margaret Hannan, C/- Billerwell Powers & Smith, GPO Box 1442, Sydney NSW	4,031.25	"	25/08/00
Mr Robert Holmes & Mrs Joan Lucille Holmes Strathearn, 16 Kings Park Avenue, Crawley, WA	210.00	"	24/02/00
Mr Bruce Evans Hughes, 32 Hawthorn Rd, North Caulfield	322.68	"	"
Mr Gordon Acmon Hutcheson & Mrs Noelene Marjory Hutcheson, 'Springhill' Barbers Creek Road, Tallong, NSW	630.00	"	"
Jack 1988 Pty Ltd, "Simpson Wighton Family A/C", 15 Tusmore Avenue, Tusmore, SA	268.75	"	25/08/00
Jack 1988 Pty Ltd, "Simpson Wighton Family A/C", 15 Tusmore Avenue, Tusmore, SA	262.50	"	24/02/00
Mrs Janice Gavin Johnson, 49 Ranfurlie Crescent, Glen Iris	102.69	"	"
Mrs Janice Gavin Johnson, 49 Ranfurlie Crescent, Glen Iris	105.13	"	25/08/00
J R N Twopeny Nominees Pty Ltd, 13 Provost Street, North Adelaide, SA	860.00	"	"

Dr David Thomas Kings, 50 Fawkner Street, South Yarra	162.15	”	”
Dr David Thomas Kings, 50 Fawkner Street, South Yarra	158.38	”	24/02/00
Mrs Tracey Jane Kyparissis, 6 Buckley Street, Carnegie	118.89	”	25/08/00
Mrs Tracey Jane Kyparissis, 6 Buckley Street, Carnegie	116.13	”	24/02/00
Miss Enid Bertha Lodington, 16 Yarralumla Avenue, St Ives Chase, NSW	301.00	”	25/08/00
Mikerene Pty Ltd, 11/14 Eastbourne Road, Darling Point, NSW	420.00	”	24/02/00
Mrs Lynn Andrea Pendlebury, Unit 1, 4 View Street, Chatswood, NSW	126.00	”	”
Mrs Lynn Andrea Pendlebury, Unit 1, 4 View Street, Chatswood, NSW	129.00	”	25/08/00
Mr Adrian John Robertson & Mrs Christine Dorothe Robertson “AJ & CD Robertson S/F A/C”, KPMG, Level 5, 182 George Street, Sydney, NSW	714.00	”	24/02/00
Ms Jane Elizabeth Ross Braeside, Rmb 1084, Newlyn	159.87	”	25/08/00
Sinomer Pty Ltd “La May A/C”, PO Box 639, Doncaster	215.00	”	”
Mr Trevor Lane Teale, 12 Longbourne Avenue, Notting Hill	588.00	”	24/02/00
Mr Trevor Lane Teale, 12 Longbourne Avenue, Notting Hill	602.00	”	25/08/00
Ms Kirsten Brigitte Wiley, 16 McConchie Ave, Kew East	252.00	”	24/02/00
Mrs Jane Cunningham Willett, 94 Yarrbat Avenue, Balwyn	840.00	”	”
Mr Oliver Pierce Yule & Mrs Joyce Elizabeth Yule, 37 Murrumbena Road, Murrumbena	120.40	”	25/08/00

02090

CONTACT: ELAINE V. HARE, PHONE: (03) 9611 5714.

**Unclaimed Moneys Act 1962**

Register of Unclaimed Moneys held by the —

<i>Name of Owner on Books and Last Known Address</i>	<i>Total Amount Due to Owner</i>	<i>Description Of Unclaimed Money</i>	<i>Date</i>
			<i>when Amount first became Payable</i>
<b>GES INTERNATIONAL LIMITED</b>			
	\$		
Antonio R. Fresta Pty Limited, 76 James Street, Punchbowl, NSW	234.78	Cheque	18/04/00
Antonio R. Fresta Pty Limited, 76 James Street, Punchbowl, NSW	371.82	”	01/12/00
Balvenor Pty Ltd, PO Box 5173, SCMC Nambour, Qld	124.16	”	”
Barry Phillis’s Associates Pty Ltd, “S Account” 2/122 Frome Street, Adelaide, SA	388.00	”	”
Mr Peter Ronald Hodge, 2/56 Glen Road, Toowong, Qld	100.10	”	”
Mr Russell Lindsay King & Mrs Terese Elizabeth King, “King Superannuation Fund A/C”, 14 Garratt Road, Bayswater, WA	155.20	”	”

Macwil Nominees Pty Ltd, C/- Mckinley Wilson & Co, 459 Collins Street, Melbourne	194.00	”	”
Macwil Nominees Pty Ltd, C/- Mckinley Wilson & Co, 459 Collins Street, Melbourne	122.50	”	18/04/00
Towerview Restaurant Pty Ltd, PO Box 86, New Gisborne	155.20	”	01/12/00

02091

CONTACT: ELAINE V. HARE, PHONE: (03) 9611 5714.

**Unclaimed Moneys Act 1962**

Register of Unclaimed Moneys held by the —

<i>Name of Owner on Books and Last Known Address</i>	<i>Total Amount Due to Owner</i>	<i>Description Of Unclaimed Money</i>	<i>Date when Amount first became Payable</i>
GUNNS LIMITED			
	\$		
Mr Orlando Bernardi & Ms Margaret Bernardi, “The O & M Bernardi S/F A/C”, 1 Millswyn Street, South Yarra	150.00	Cheque	27/04/00
Miss Enid Mona Campbell, Faculty of Law, Monash University, PO Box 92, Clayton	512.16	”	27/10/00
Mr Walter George Chapman, Waverley Aged Care, 29-33 Chesterville Road, Glen Waverley	341.76	”	”
Corryong Essential Oils Pty Ltd, “Peter Nankervis S/Fund A/C”, PO Box 8, Corryong	160.00	”	”
Mr Michael John Crisp & Mr Andrew Alan Crisp & Mrs Phillipa Mary Ditcham, 64 Walana Street, Geilston Bay, Tas.	256.32	”	”
Mr Michael John Crisp & Mr Andrew Alan Crisp & Mrs Phillipa Mary Ditcham, 64 Walana Street, Geilston Bay, Tas.	160.20	”	27/04/00
Mrs Gwenda Walford Hosking, 239 Burchfield Avenue, Deniliquin, NSW	320.00	”	27/10/00
Estate Late Wilfred John Louis Manthei, C/- Tasmanian Permanent Executors, PO Box 286C, Launceston, Tas.	256.32	”	”
Ms Marie McGoldrick, 57 Landsdown Terrace, Cashmere, Christchurch 3, New Zealand	500.00	”	27/04/00
Mr Renouf Bell Middleton & Mrs Ann Coralie Middleton, “Middleton Family Super A/C”, 26 Perrins Drive, Low Head, Tas.	196.08	”	27/10/00
MKD Properties Pty Ltd, PO Box 724, Riverside, Launceston Tas.	160.00	”	”

MKD Properties Pty Ltd, PO Box 724, Riverside, Launceston Tas.	100.00	''	27/04/00
Mr Neville Laurence Oliver & Mrs Pamela Margaret Oliver, "Super Fund A/C", 154 Bakers Creek Road, Lucaston, Tas.	160.00	''	27/10/00
Mr Neville Laurence Oliver & Mrs Pamela Margaret Oliver, "Super Fund A/C", 154 Bakers Creek Road, Lucaston, Tas.	100.00	''	27/04/00
Mrs Aileen Joy Plant, 3/5 Princes Road, Crawley WA	160.00	''	27/10/00
Mrs Aileen Joy Plant, 3/5 Princes Road, Crawley WA	100.00	''	27/04/00
Mr Gregory Short, "Short Family A/C", 2 Wagner Street, Blackburn South	175.00	''	''
Twenty Second Sepleda Pty Ltd, PO Box 423, Reservoir	160.00	''	27/10/00
Twenty Second Sepleda Pty Ltd, PO Box 423, Reservoir	100.00	''	27/04/00

02094

CONTACT: ELAINE V. HARE, PHONE: (03) 9611 5714.

**Unclaimed Moneys Act 1962**

Register of Unclaimed Moneys held by the —

<i>Name of Owner on Books and Last Known Address</i>	<i>Total Amount Due to Owner</i>	<i>Description Of Unclaimed Money</i>	<i>Date when Amount first became Payable</i>
<b>HOBSONS BAY CITY COUNCIL</b>			
	\$		
ER & D Services, Locked Bag 10, Parkville Roads & Traffic Authority, GPO Box K198, Haymarket, NSW	243.00	Cheque	06/07/00
Cityside Constructions, PO Box 821, Tullamarine	114.75	''	28/09/00
R. Allum, PO Box 71, Belgrave	400.00	''	26/10/00
Videoit, 2 Dane Street, Yarraville	500.00	''	''
Dragan Kocic, 1/139 Maidstone Street, Altona	100.00	''	09/11/00
Hollcon, C/-123 Camberwell Road, East Hawthorn	100.00	''	''
S. J. Ellul, 27 Beach Street, Altona	400.00	''	30/11/00
B. & K. Uren, PO Box 1322, Hoppers Crossing	400.00	''	''
Jany Murat, 100 The Esplanade, Williamstown	500.00	''	''
Noah's Ark-Playworkds Resources, 4 Duke Street, Prahran	120.00	''	14/12/00
Unique Poser Pty Ltd, 1st Floor, 462 City Road, South Melbourne	156.00	''	''
Helena Chandler & Daryl Pate, 18 Coolabah Drive, Eltham	500.00	''	25/01/01
ACC Investments, PO Box 165, Altona North	100.00	''	08/02/01
	400.00	''	15/02/01

02055

CONTACT: HEATHER BOYD, PHONE: (03) 9932 1020.



**Unclaimed Moneys Act 1962**

Register of Unclaimed Moneys held by the —

<i>Name of Owner on Books and Last Known Address</i>	<i>Total Amount Due to Owner</i>	<i>Description Of Unclaimed Money</i>	<i>Date when Amount first became Payable</i>
R. E. APPLEBY PTY LTD			
	\$		
Robyn Leese, 25 Olive Grove, Tecoma 02171 CONTACT: JACKIE HAMPSON, PHONE: (03) 9729 3555.	458.85	Refund Rent	06/09/99

**Unclaimed Moneys Act 1962**

Register of Unclaimed Moneys held by the —

<i>Name of Owner on Books and Last Known Address</i>	<i>Total Amount Due to Owner</i>	<i>Description Of Unclaimed Money</i>	<i>Date when Amount first became Payable</i>
RUSSELL KENNEDY SOLICITORS			
	\$		
Samuel Hordern Annuities Trust, C/- K. P. Abbott & Co., Solicitors, 1628 High Street, Glen Iris	30,000.00	Cheque	18/03/94
02007 CONTACT: CATHY SPEED, PHONE: (03) 9275 7911.			

**Unclaimed Moneys Act 1962**

Register of Unclaimed Moneys held by the —

<i>Name of Owner on Books and Last Known Address</i>	<i>Total Amount Due to Owner</i>	<i>Description Of Unclaimed Money</i>	<i>Date when Amount first became Payable</i>
JOHN W. BALL & SONS			
	\$		
Dr Richard Miles, 13 Mayfield Grove, North Caulfield	120.00	Cheque	01/01/01
02014 CONTACT: SHIRLEY VASIC, PHONE: (03) 9347 8311.			

**Unclaimed Moneys Act 1962**

Register of Unclaimed Moneys held by the —

<i>Name of Owner on Books and Last Known Address</i>	<i>Total Amount Due to Owner</i>	<i>Description Of Unclaimed Money</i>	<i>Date when Amount first became Payable</i>
LANDER & ROGERS LAWYERS			
	\$		
M. Dum, 190/195 Napier Street, Coburg East	300.00	Cheque	24/07/99
02006 CONTACT: BETH VIZE, PHONE: (03) 9672 9111.			

**Unclaimed Moneys Act 1962**

Register of Unclaimed Moneys held by the —

<i>Name of Owner on Books and Last Known Address</i>	<i>Total Amount Due to Owner</i>	<i>Description Of Unclaimed Money</i>	<i>Date when Amount first became Payable</i>
MOORABOOL SHIRE COUNCIL			
	\$		
Matheson, G. A., PO Box 89, Blackwood	100.00	Cheque	24/06/99
Reginato, R., 12 Bradshaw Street, Ballarat	150.00	"	17/03/00
02054 CONTACT: FAYE PARRY, PHONE: (03) 5366 7100.			

**Unclaimed Moneys Act 1962**

Register of Unclaimed Moneys held by the —

<i>Name of Owner on Books and Last Known Address</i>	<i>Total Amount Due to Owner</i>	<i>Description Of Unclaimed Money</i>	<i>Date when Amount first became Payable</i>
MOTORCHARGE LTD			
	\$		
Ampol Davey Street, 156 Davey Street, South Hobart, Tas. 7 – Eleven Baxter,	1,043.33	Cheque	29/05/00
Cnr Frankston Flinders & Moorooduc Roads, Baxter	362.48	"	12/05/97
Geelong Road Mobile Motors 725 Geelong Road, Midlands	1,039.55	"	03/08/98

Sahar Petroleum Hopkins Street, 24 Hopkins Street, Footscray	321.27	''	23/11/98
BP Oban Road Ringwood, Cnr Maroondah Hwy & Oban Rd, Ringwood	1,379.95	''	30/11/98
Thoolen Engineering, Moore Street, Robinvale	827.64	''	28/12/98
Sahar Petroleum Hopkins Street, 25 Hopkins Street, Footscray	1,146.78	''	23/11/98
BP Oban Road Ringwood, Cnr Maroondah Hwy & Oban Rd, Ringwood	1,399.96	''	30/11/98
Mobil Eastway, 104 Princes Highway, Trafalgar	138.74	''	15/03/99
Mobil Car Care Ringwood, 71 Maroondah Highway, Ringwood	661.78	''	12/07/99
Metro Fuel Carrum Downs 467 Frankston-Dandenong Rd, Carrum Downs	103.60	''	27/09/99
Moore Energy P/L, 42 Ryley St, Wangaratta	1,464.49	''	15/11/99
Narracan Gate Motors, 43 Princes Hwy, Trafalgar	224.77	''	06/12/99
Newport Fuel Service Station, 45 Mason St, Newport	213.72	''	10/01/00
New Dookie Road Ampol, New Dookie Road, Shepparton	189.14	''	24/01/00
Goodyear Bendigo City, 30 Garsed Street, Bendigo	230.66	''	31/07/00

02013

CONTACT: KAREN FULFORD, PHONE: (03) 9862 6000.

**Unclaimed Moneys Act 1962**

Register of Unclaimed Moneys held by the —

<i>Name of Owner on Books and Last Known Address</i>	<i>Total Amount Due to Owner</i>	<i>Description Of Unclaimed Money</i>	<i>Date when Amount first became Payable</i>
AXA-NATIONAL MUTUAL FINANCIAL SERVICES (LIFE)			
\$			
Anderson, Anthony, 8 Axehead Road, Roxby Downs, SA	100.00	Cheque	12/02/01
Andronos, Kevin, 8 Carrington Street, Balmain, NSW	1,006.81	''	17/05/00
Azzopardi, Joe, 457 Bulmans Road, Melton	317.84	''	11/09/00
Beckingsale, Anthony, 77A Furness Street, Kangaroo Flat	130.37	''	29/08/00
Beer, Laurence Keith, 66 Ben Nevis Rd, Cranebrook, NSW	180.31	''	02/01/01
Blanchard, James, 24 Westview Street, Currumbin, Qld	147.30	''	29/08/00
Braden, Shane, PO Box 2248, Mount Isa, Qld	155.35	''	31/08/00
CKT Manufacturing, The Moorocan Elkorauf, Surfers Paradise, Qld	167.13	''	12/06/00
Cole, Devin F., 3/120 Marine Parade, Cottesloe, WA	246.99	''	12/05/00
Dixon, David, 26 Trentham Court, Wattle Grove, NSW	123.05	''	29/01/01
Fabian, Mark, 4 Beckington Way, Karrinyup, WA	132.29	''	09/03/00
Gidley, Peter John, 1 Newby Drive, Edmonton, Qld	190.66	''	10/08/00
Jarrett, Brad William, 11 Anakai Drive, Jamisontown, NSW	143.82	''	13/03/00
Johnston, Mathew Jason, 69/47 Kennedy St, Kingston, ACT	121.77	''	03/05/00
Keniry, Bryan, 15 Franis Street, Fairlight, NSW	295.76	''	31/07/00
Kustreba, Ivan, 2A Cabena Crescent, Chadstone	107.61	''	31/05/00

Lawson, Gary, (Beneficiary of Mathew Lawson) 7 Vanessa Crescent, Wheelers Hill	253.57	”	15/09/00
Loh, Louise, 6 Lafrance Court, Mermaid Waters, Qld	103.74	”	27/04/00
Manolis, Manuel C., 3/35 Bradshaw Terrace, Nakara, NT	275.38	”	29/01/01
Merryfill, Noel Frederick, PO Box 145, Hawker, ACT	181.37	”	31/03/00
Mueller, Anthony Matthew, 6 Cambridge Place, Clovelly Park, SA	148.02	”	16/11/00
Myers, Gregory P., 14 Bouganville Street, Mount Isa, Qld	128.14	”	27/11/00
Saunders, Ronald, PO Box 209, Pendle Hill, NSW	128.77	”	24/07/00
Simonis, Magdalena, PO Box 146, Clayton South	174.88	”	27/09/00
Slater, John Paul, 21 Gouronga Drive, Craigmore, SA	146.34	”	18/10/00
Spratt, David, 17 Mugrove Road, Geilston Bay, Tas.	111.99	”	08/06/00
Tick Tock Australia Pty Ltd, Level 9, City Arcade Tower, 207 Murray Street, Perth, WA	108.48	”	23/05/00
Vranic, John A., 20 Addison Street, Wetherill Park, NSW	155.97	”	03/05/00
Woyc, Gayle, 77 Andrew Thompson Drive, McGraths Hill, NSW	145.69	”	17/01/01
Young, Edgar, 12 John Street, Norseman, WA	472.64	”	30/06/00

02072

CONTACT: KATH HARDIDGE, PHONE: (03) 9287 4811.

**Unclaimed Moneys Act 1962**

Register of Unclaimed Moneys held by the —

<i>Name of Owner on Books and Last Known Address</i>	<i>Total Amount Due to Owner</i>	<i>Description Of Unclaimed Money</i>	<i>Date when Amount first became Payable</i>
<b>GRAND HOTEL GROUP</b>			
	\$		
Allcott Holdings Pty Ltd, PO Box 1082 North Sydney NSW	190.00	Cheque	29/02/00
Mr John Robert Bell & Mrs Catherine Bell, “Aust Drilling Super A/C” PO Box 320 Collins Street West, Melbourne	152.00	”	”
Mr John Robert Bell & Mrs Catherine Bell, “Aust Drilling Super A/C” PO Box 320 Collins Street West, Melbourne	160.00	”	29/08/00
Bellset Nominees Pty Ltd, Level 45, 80 Collins Street, Melbourne	800.00	”	”
Catrius Pty Ltd, “Super Fund A/C”, 16 Watts Parade, Mount Eliza	380.00	”	29/02/00
Mr Jeremy Charles Coutts & Mr Matthew Thomas Coutts & Miss Georgina Louise Coutts & Mr Lucas Benjamin Coutts, PO Box 549, Horsham	177.84	”	29/08/00
Mrs Jacqueline Ann Grove, “Super Fund A/C”, 5/1 Bridges Road, Melville, WA	1,280.00	”	”

Mr Sydney Kaufman & Mrs Esther Kaufman, 2/4 Maple Street, Toorak	1,209.96	”	05/07/00
Mrs Margaret Knewstub & Mr David Knewstub, “Eccles Family Pms A/C”, Level 15, 44 St Georges Terrace, Perth, WA	769.20	”	29/08/00
Mr Alan James Phillips, “Share Trading A/C No 2”, 4 Cypress Street, Blackwater, Qld	175.33	”	29/02/00
Renouf & Associates Pty Ltd, “Superannuation Fund A/C”, 3rd Floor 22 William Street, Melbourne	3,237.04	”	05/07/00
Mr Barry Rodwell & Mrs Gillian Rodwell, “Rodwell Super Fund A/C”, C/- Scott Adv Services 30 Young Street, Wollongong, NSW	123.36	”	29/08/00
Mr Andrew Leon Tannahill, 8 Katz Place, Spence, ACT	146.15	”	29/02/00
Mr Andrew Leon Tannahill, 8 Katz Place, Spence, ACT	153.84	”	29/08/00
Mr Matthew John Wallace, 8 Milham Ave, Eastwood, NSW	204.59	”	29/02/00
Mr Matthew John Wallace, 8 Milham Ave, Eastwood, NSW	215.36	”	29/08/00

02092

CONTACT: ELAINE V. HARE, PHONE: (03) 9611 5714.

---

**PROCLAMATIONS**

**Trustee (Amendment) Act 2001**

PROCLAMATION OF COMMENCEMENT

I, John Landy, Governor of Victoria, with the advice of the Executive Council and under section 2(2) of the **Trustee (Amendment) Act 2001**, fix 31 May 2002 as the day on which the remaining provisions of that Act come into operation.

Given under my hand and the seal of  
Victoria on 28 May 2002.

(L.S.) JOHN LANDY  
Governor  
By His Excellency's Command

CHRISTINE CAMPBELL  
Minister for Consumer Affairs

---

**Stamps (Secondary Mortgage Market)  
Act 1988**

PROCLAMATION OF COMMENCEMENT

I, John Landy, Governor of Victoria, with the advice of the Executive Council and under section 2(2) of the **Stamps (Secondary Mortgage Market) Act 1988**, fix 31 May 2002 as the day on which section 6 of that Act comes into operation.

Given under my hand and the seal of  
Victoria on 28 May 2002.

(L.S.) JOHN LANDY  
Governor  
By His Excellency's Command

JOHN BRUMBY MP  
Treasurer

---

**Public Notaries Act 2001**

PROCLAMATION OF COMMENCEMENT

I, John Landy, Governor of Victoria, acting with the advice of the Executive Council and under section 2(1) of the **Public Notaries Act 2001**, fix 6 June 2002 as the day on which that Act comes into operation.

Given under my hand and the seal of  
Victoria on 28 May 2002.

(L.S.) JOHN LANDY  
Governor  
By His Excellency's Command

ROB HULLS  
Attorney-General

---

**GOVERNMENT AND OUTER BUDGET SECTOR AGENCIES  
NOTICES**

**SHIRE OF MOIRA**

Proposed Road Discontinuance

Pursuant to Section 206 and Schedule 10, Clause 3 of the **Local Government Act 1989**, the Council of the Shire of Moira, at its meeting on 29 January 2002, formed the opinion that the section of un-named laneway located off William Street, Cobram, shown hatched on the plan hereunder, is not reasonably required for public use and resolved to discontinue that part of the laneway.

Upon discontinuance, the land will be sold to the adjoining owner.

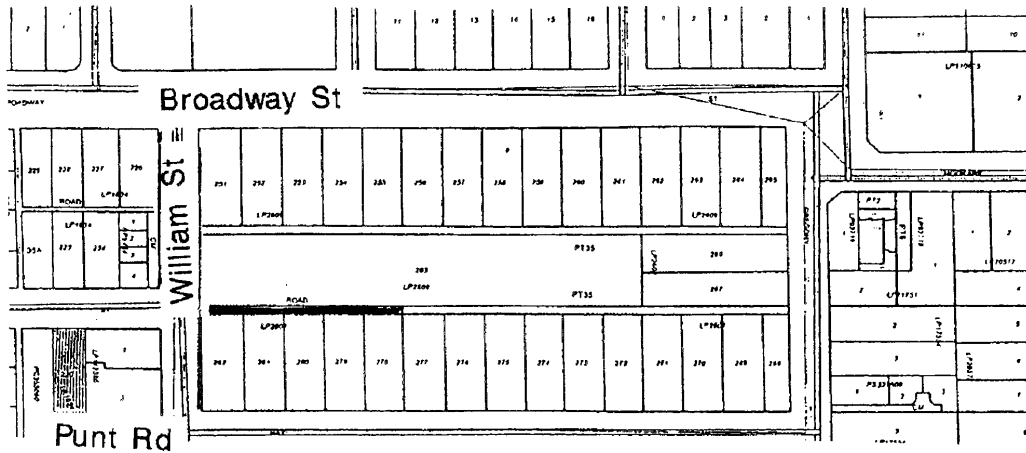

GAVIN CATOR  
Chief Executive Officer



Ararat Rural City

**Public Holidays Act 1993**

Ararat Rural City Council

The Ararat Rural City Council, under Section 7 of the **Public Holidays Act 1993** appoints Tuesday 5 November 2002 as a half day (from 12 noon) Public Holiday throughout its Municipal District.

WILLIAM E. BRAITHWAITE  
Chief Executive Officer

NORTHERN GRAMPIANS SHIRE COUNCIL

Road Discontinuance

Pursuant to Section 206 and Schedule 10, Clause 3 of the **Local Government Act 1989** the Northern Grampians Shire Council at its ordinary meeting held on 2 May 2002 formed the opinion that the road west of Griffiths Street, Stawell shown hatched on the plan set out below and being part of Crown Allotments 5, 6 and 7, Section 80B, Township of Stawell is not reasonably required as a road for public use and has resolved to discontinue the road and to sell the land from the road by private treaty.

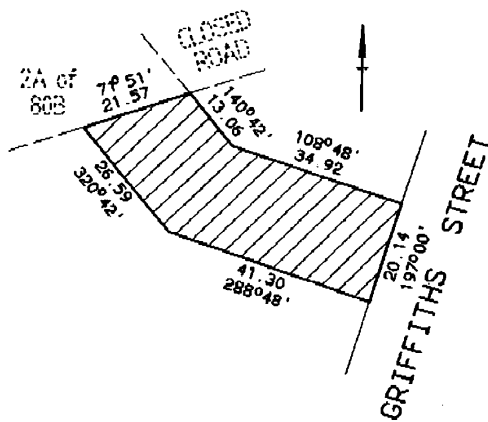

PETER BROOKS  
Chief Executive Officer

NORTHERN GRAMPIANS SHIRE COUNCIL  
Road Discontinuance

Pursuant to Section 206 and Schedule 10, Clause 3 of the **Local Government Act 1989** the Northern Grampians Shire Council at its ordinary meeting held on 2 May 2002 formed the opinion that the road at the rear of 140 Gold Reef Mall, Stawell shown hatched on the plan set out below and being part of Crown Allotment 6, Section 35, Parish of Stawell is not reasonably required as a road for public use and has resolved to discontinue the road and to sell the land from the road by private treaty.

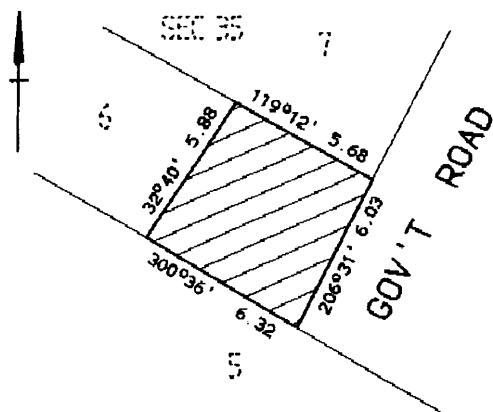

PETER BROOKS  
Chief Executive Officer

COLAC OTWAY SHIRE

Local Law No. 13 –  
Amendment to Meeting Procedures

The Council of Colac Otway Shire gives notice that at a meeting on 22 May 2002 Local Law No. 13 was approved.

The purpose of this Local Law is to amend Local Law No 4 – Meeting Procedures. The Local Law will come into operation on 1 July 2002 and operate throughout the municipal district of the Colac Otway Shire.

The general content of this Local Law is:

- Providing for the Order of Business at any Ordinary Meeting;
- Providing for a Question Time during every Ordinary/Special/Annual Report meeting of Council to enable questions by the public gallery to be addressed by members of Council/Staff;
- Provision for Council meetings to be adjourned by a resolution adopted by the majority of Councillors present at a meeting.

A copy of the Local Law may be obtained from Council's Customer Service Centre at 2-4 Rae Street, Colac or Nelson Street, Apollo Bay during business hours.

Submissions to the content of the proposed Local Law are invited in accordance with Section 223 of the **Local Government Act 1989** and should be lodged with the Chief Executive Officer within 14 days of this notice. Submitters should indicate whether or not the author wishes to be heard in support of their submission.

GLENN PATTERSON  
Chief Executive Officer

STRATHBOGIE SHIRE COUNCIL

**Local Government Act 1989**

Adoption of Local Law

Municipal Places Local Law No. 5 –  
Consumption of Liquor in Public Places

Pursuant to Section 111(1) of the **Local Government Act 1989**, it is advised that the Strathbogie Shire Council, at its meeting of 21 May 2002, formally resolved to make:–

- Municipal Places Local Law No. 5 –  
Consumption of Liquor in Public Places



The principal objectives of this local law are to:—

- (a) regulate and control the consumption of liquor and possession of liquor other than in a sealed container:
  - (i) on a road; or
  - (ii) in or at a public place; or
  - (iii) in or on a stationary vehicle; or
  - (iv) on vacant private land;
- (b) prevent behaviour which:
  - (i) constitutes, or may constitute, a nuisance; or
  - (ii) may be detrimental to health or safety; or
  - (iii) affects the enjoyment of public and other places; and
- (c) provide for the peace, order and good government of the municipal district.

The local law applies and has operation throughout the whole of the municipal district.

#### Clause 7.1

A person must not, without a permit, between the hours of 11.00 pm and 10.00 am:—

- 7.1.1 on a road; or
- 7.1.2 in or at a public place; or
- 7.1.3 in or on a motor vehicle which is on or at a public place,

consume, or have in his or her possession or control, any liquor other than liquor in a sealed container.

Penalty: 2 penalty units.

Copies of the Strathbogie Shire Council Municipal Places Local Law No. 5 – Consumption of liquor in Public Places may be obtained at the Council offices, Binney Street, Euroa or High Street, Nagambie, during office hours.

KEVIN J. HANNAGAN  
Chief Executive Officer –  
Strathbogie Shire Council

#### STRATHBOGIE SHIRE COUNCIL

##### Public Notice

##### Local Law No. 1 –

##### Meeting Procedures and Common Seal

The abovementioned Local Law provides a framework for the conduct of Council Meetings and use of Council's Common Seal.

The Local Law was amended to indicate that the Council Meeting Agenda will now be

available at least six (6) days before the meeting. The Local Law was adopted by Council at its meeting of 21 May 2002.

A copy of the Local Law may be obtained from the Euroa Civic Centre, corner of Binney and Bury Streets, Euroa, or the Nagambie Community Complex, High Street, Nagambie.

KEVIN J. HANNAGAN  
Chief Executive Officer

#### Planning and Environment Act 1987

#### ALPINE RESORTS PLANNING SCHEME

#### Notice of Amendment

#### Amendment C9

The Minister for Planning has prepared Amendment C9 to the Alpine Resorts Planning Scheme.

The amendment introduces an Erosion Management Overlay (EMO) across the six Alpine Resorts with Schedule 1 and Schedule 2 having been formulated with the assistance of hazard ratings identified by the Snowy Mountains Engineering Corporation (SMEC). The Amendment also lists additional circumstances (outlined in Schedule 2 to the Erosion Management Overlay) that require more detailed consideration of geo-technical conditions of the land.

A copy of the Amendment can be inspected, free of charge, during office hours, at:

- Department of Infrastructure, Planning Information Centre, Upper Plaza, Nauru House, 80 Collins Street, Melbourne;
- Department of Infrastructure, Eastern Regional Office, 120 Kay Street, Traralgon, the North-Eastern Regional Office, 50–52 Clarke Street, Benalla;
- Falls Creek Resort Management Board, Bogong High Plains Road, Falls Creek Alpine Resort;
- Lake Mountain Resort Management Board, Lake Mountain Road, Lake Mountain Alpine Resort;
- Mt Baw Baw Resort Management Board, Mt Baw Baw Access Road, Mt Baw Baw Alpine Resort;
- Mt Buller Resort Management Board, Mt Buller Tourist Road, Mt Buller Alpine Resort;

- Mt Hotham Resort Management Board, Great Alpine Road, Mt Hotham Alpine Resort;
- Mt Stirling Resort Management Board, C/- Delatite Shire Council, Mansfield Service Centre, Highett Street, Mansfield;
- Alpine Shire Office, Great Alpine Road, Bright;
- Delatite Shire Council Office, Mansfield Service Centre, Highett Street, Mansfield;
- Baw Baw Shire Council Office, Warragul Customer Service Centre, 61 Smith Street, Warragul.
- J. C. Mills Reserve, 190–202 Cleeland Street, Dandenong;
- Tatterson Park, 62 Chapel Road, Keysborough;
- Noble Park Swim Centre, corner Memorial Drive and Heatherton Road, Noble Park;
- Dandenong Basketball Stadium – 270 Stud Road, Dandenong.

Submissions about the amendment must be sent to: Minister for Planning, Attention: Adrian Williams, Planning Panels Victoria, Department of Infrastructure, PO Box 2797Y, Melbourne 3001 by 30 July 2002.

PAUL JEROME  
Executive Director  
Planning, Heritage and  
Building Division  
Department of Infrastructure

The Amendment can be inspected during office hours and free of charge at: (1) the City of Greater Dandenong: Dandenong Office, 39 Clow Street, Dandenong and (2) the Department of Infrastructure, Upper Plaza, Nauru House, 80 Collins Street, Melbourne.

Any person affected by the amendment may make a submission in writing.

Please be aware that copies of objections/submissions received may be made available to any person for the purpose of consideration as part of the planning process.

Submissions must be sent to: The Manager Strategic and Statutory Planning, City of Greater Dandenong, PO Box 200, Springvale, Vic. 3171.

Submissions must be received by 1 July 2002.

### **Planning and Environment Act 1987**

#### **GREATER DANDENONG PLANNING SCHEME**

##### **Notice of Amendment**

##### **Amendment C29**

The City of Greater Dandenong has prepared Amendment C29 to the Greater Dandenong Planning Scheme and is the Planning Authority for the Amendment.

The Amendment proposes to substitute schedules to Public Park and Recreation Zone, Public Use Zone and Urban Floodway Zone to allow site specific advertising sign controls in these zones.

The Amendment affects the following land:

- Dandenong Municipal Offices, Library & Market Precinct, 39 Clow Street & 16–46 Cleeland Street, Dandenong;
- Springvale Municipal Office, Library & Town Hall, 397–405 Springvale Road, Springvale;
- Greaves Reserve, 4–30 Bennett Street, Dandenong;
- Dandenong Park, Lonsdale & Pultney Streets, Dandenong;

### **Planning and Environment Act 1987**

#### **KINGSTON PLANNING SCHEME**

##### **Notice of Amendment**

##### **Amendment C22**

Who is the Planning Authority?

This Amendment has been prepared by the City of Kingston. The City of Kingston is the planning authority for this Amendment.

What the Amendment does?

The Amendment rezones land at 642–660 Springvale Road and 369–385 Spring Road, Dingley Village from Public Use Zone 3 (Health and Community) to Residential 1 Zone and includes 369–385 Spring Road, Dingley Village, within a Development Plan Overlay.

Land affected by the Amendment

The Amendment applies to land known as: 642–660 Springvale Road, Dingley Village which is contained in Plan of Consolidation 107356, Certificate of Title Volume 09296, Folio 733; and 369–385 Spring Road, Dingley Village, Part Lot 54, LP4681, Certificate of Title Volume 7898, Folio 091.

Why the Amendment is required?

The subject land is located in a Public Use Zone 3 (Health and Community). This zone is only applicable to public land and as the subject land is in private ownership the application of the Public Use Zone is contrary to the Ministerial Direction for the Form and Content of Planning Schemes under Section 7(5) of the **Planning and Environment Act 1987**. The rezoning of the land to a more suitable zone is required.

A separate planning permit application to use and develop the land fronting Springvale Road for the purpose of a retirement village has been lodged with the City of Kingston.

Where you may inspect this amendment

The Amendment is available for public inspection, free of charge, during the office hours at the following places: City of Kingston, Mentone Customer Service Centre, Brindisi Street, Mentone; Dingley Library, 9B, 79 Centre Dandenong Road, Dingley and Department of Infrastructure, Planning Information Centre, Upper Plaza, Nauru House, 80 Collins Street, Melbourne.

Submissions about the Amendment must be sent to: Attention: Joel Twining, Strategic Planning, Kingston City Council, PO Box 1000, Mentone, Vic. 3194 by Monday 1 July 2002.

ROB SKINNER  
Chief Executive

---

**Planning and Environment Act 1987**

MACEDON RANGES PLANNING SCHEME

Notice of Amendment

Amendment C13

This Amendment has been prepared by the Department of Education, Employment and Training. Macedon Ranges Shire Council is the planning authority for this Amendment.

The Amendment applies to 3.076 hectares of land on the west side of Edgcombe Street, Kyneton, south of Sturt Street and north of the St Mary's Primary School. The land is more specifically described as Lot 2 on Plan of Subdivision 410524D, Parish of Lauriston, County of Dalhousie.

The Amendment proposes to rezone the land from Public Use Zone 2 (Education) to Residential 1 Zone.

The land is vacant and surplus to the education needs of the Kyneton area and accordingly will not be developed for educational purposes. The Amendment will provide the opportunity for unused and vacant land to be developed for residential purposes in the central part of Kyneton.

A copy of the Amendment may be inspected, free of charge, at the following locations during office hours: Macedon Ranges Shire Council, 129 Mollison Street, Kyneton; Department of Infrastructure, Northern Regional Office, 57 Lansell Street, Bendigo and Department of Infrastructure, Planning Information Centre, Upper Plaza, Nauru House, 80 Collins Street, Melbourne.

Submissions about the Amendment must be sent to: Macedon Ranges Shire Council, PO Box 151, Kyneton, Vic. 3444 by 5.00 pm 1 July 2002.

---

**Planning and Environment Act 1987**

MOONEE VALLEY PLANNING SCHEME

Notice of Amendment

Amendment C33

Moonee Valley Council has prepared Amendment C33 to the Moonee Valley Planning Scheme.

The Amendment proposes to remove the Public Acquisition Overlay (PAO1) from the Moonee Valley Planning Scheme on the 7 properties located at the north west end of Lebanon Street and Eric Street, Strathmore, alongside the eastern boundary of the Essendon Airport.

The Amendment will modify Map 3PAO to remove the PAO1 from the subject area.

The Amendment is available for public inspection, free of charge, during office hours at the following places: Department of Infrastructure, Customer Service Centre, Upper Plaza, Nauru House, 80 Collins Street, Melbourne 3000 and City of Moonee Valley, 9 Kellaway Avenue, Moonee Ponds 3039.

Submissions about the Amendment must be received by 12 July 2002 and addressed to: Attention: Simon Vittorio, Strategic Planning, City of Moonee Valley, PO Box 126, Moonee Ponds 3039.

Dated 24 May 2002

SVEN KLING  
Chief Executive

---

**Planning and Environment Act 1987**

**MORNINGTON PENINSULA  
PLANNING SCHEME**

**Notice of Amendment**

**Amendment C44**

**Notice of an Application for Planning Permit**

**Application No. CP 02/001**

The land affected by the Amendment is: No. 17–19 Pine Avenue, Mornington (being Lot 1 and Reserve No. 1 on PS 444660D).

The land affected by the application is: No. 17–19 Pine Avenue, Mornington (being Lot 1 and Reserve No. 1 on PS 444660D).

The Amendment proposes to rezone parts of the land from a Public Use Zone – Schedule 1 (Service and Utility) to a Residential 1 Zone and a Public Use Zone – Schedule 6 (Local Government).

The application is for a permit to subdivide the land that is proposed to be included in the Residential 1 Zone into 22 lots and to remove pine trees.

The person who requested the Amendment and the applicant for the permit is South East Water Ltd.

You may inspect the Amendment and the application, and any documents that support the Amendment and application, and the explanatory report about the Amendment and application, at the office of the planning authority: Mornington Peninsula Shire Council, Mornington Office – Queen Street, Mornington and the Department of Infrastructure, Customer Service Centre, Upper Plaza, Nauru House, 80 Collins Street, Melbourne.

This can be done during office hours and is free of charge.

Any person who may be affected by the Amendment or by the granting of the permit may make a submission to the planning authority.

The closing date for submissions is Wednesday 3 July 2002.

Any submission must be sent to the Mornington Peninsula Shire Council, Private Bag 1000, Rosebud 3939.

Please note that any submissions that are received may be made available for public inspection.

LYNTON SHEDDEN  
Manager – Strategic Planning  
Mornington Peninsula Shire Council

**Planning & Environment Act 1987**

**SOUTH GIPPSLAND PLANNING SCHEME**

**Notice of Amendment**

**Amendment C6**

South Gippsland Shire Council, at the request of Vicroads, has prepared Amendment C6 to the South Gippsland Planning Scheme.

The Amendment proposes to change the Planning Scheme by including land between Toora Gunyah Road and approximately 1.4 km west of Careegs Road, generally being to the west of Toora and on the north and south side of the existing Highway in the Public Acquisition Overlay (PAO).

The land proposed to be included in the PAO is generally adjacent to the South Gippsland Highway between Toora Gunyah Road and approximately 1.4 km west of Careegs Road. The Amendment will facilitate the acquisition of this land by Vicroads for the future construction of improvements to the Highway in accordance with the South Gippsland Highway Corridor Strategy.

A copy of the Amendment can be inspected at South Gippsland Shire Council, 9 Smith Street, Leongatha; the Department of Infrastructure, Customer Service Centre, 80 Collins Street, Melbourne and Department of Infrastructure Regional Office, 120 Kay Street, Traralgon.

Inspection of the Amendment will be free of charge to any person during office hours.

Any submission you may wish to make in respect of the Amendment must be made in writing and sent to the Chief Executive Officer, South Gippsland Shire Council, Private Bag 4, Leongatha 3953.

All submissions must be received by Council no later than the 1 of July 2002.

If you have any questions about the Amendment please contact David Young, Planning Officer, on (03) 5662 9325.

PETER BULL  
Chief Executive Officer

**Planning and Environment Act 1987**

**SOUTH GIPPSLAND PLANNING SCHEME**

**Notice of Amendment**

**Amendment C8**

South Gippsland Shire Council, at the request of Vicroads, has prepared Amendment C8 to the South Gippsland Planning Scheme.

The Amendment proposes to change the Planning Scheme by including land between Old Meenyan Road and Minns Road in the Public Acquisition Overlay (PAO).

The land proposed to be included in the PAO is generally adjacent to the South Gippsland Highway between Old Meenyan Road and Minns Road, Koonwarra. The Amendment will facilitate the acquisition of this land by Vicroads for the future construction of improvements to the Highway in accordance with the South Gippsland Highway Corridor Strategy.

A copy of the Amendment can be inspected at South Gippsland Shire Council, 9 Smith Street, Leongatha; the Department of Infrastructure, Customer Service Centre, 80 Collins Street, Melbourne, and Department of Infrastructure Regional Office, 120 Kay Street, Traralgon.

Inspection of the Amendment will be free of charge to any person during office hours.

Any submission you may wish to make in respect of the Amendment must be made in writing and sent to the Chief Executive Officer, South Gippsland Shire Council, Private Bag 4, Leongatha 3953.

All submissions must be received by Council no later than 1 of July 2002.

If you have any questions about the Amendment please contact David Young, Planning Officer, on (03) 5662 9325.

PETER BULL  
Chief Executive Officer

### **Planning and Environment Act 1987**

#### **SURF COAST PLANNING SCHEME**

##### Notice of Amendment

##### Amendment C9

Surf Coast Shire has prepared Amendment C9 to the Surf Coast Planning Scheme.

The Amendment proposes to rezone a portion of the land at 1210 Ghazeeophore Road and 460 Grossmans Road, Torquay from Rural (RUZ) to Public Use – Schedule 1 Service and Utility (PU1Z), and to amend the Schedule to the Industrial 3 Zone by inserting “0m<sup>2</sup>” as a minimum leasable floor area for a ‘Lighting Shop’ and ‘Restricted Retail Premises other than Equestrian Supplies, Lighting Shop and Party Supplies’.

The Amendment, including explanatory statement, can be inspected at: Surf Coast Shire Planning Office, Level 1, 16 Gilbert Street, Torquay; Department of Infrastructure, South Western Region Office, 180 Fyans Street, South Geelong and Department of Infrastructure, Level 3 Plaza, Nauru House, 80 Collins Street, Melbourne.

Any person may make a submission on the Amendment. Submissions should clearly state all of the grounds on which the Amendment is supported or opposed and indicate whether the submitter wishes to be heard in respect of the submission at any subsequent panel hearing.

Submissions about the Amendment must be sent to Mr Doug McNeill – Senior Strategic Planner, Planning and Environment Unit, Surf Coast Shire, PO Box 350, Torquay 3228, by 30 June 2002.

RAEWYN HANSEN  
Manager – Planning and Environment

Creditors, next-of-kin and others having claims against the estate of any of the undermentioned deceased persons are required to send particulars of their claims to State Trustees Limited, ACN 064 593 148, 168 Exhibition Street, Melbourne, Victoria 3000, the personal representative, on or before 30 July 2002 after which date State Trustees Limited may convey or distribute the assets having regard only to the claims of which State Trustees Limited then has notice.

AGNUS, Frederick Richard, late of Avonsleigh Terrace Hostel, 41–43 Robe Street, St Kilda, retired, who died 20 January 2002.

BARKER, Betty Marie, late of 4 The Boulevard, Pascoe Vale South, housewife, who died 12 May 2002.

BRAY, Joseph, late of Kingston Centre – Warrigal Road, Cheltenham, pensioner, who died 11 May 2002.

DELBRIDGE, John, late of Unit 3, 20 Belmore Road, Sunshine, who died 27 March 2002.

GOLDING, Betty Marion, late of Flat 2, 5A Creswick Street, Hawthorn, retired, who died 7 March 2002.

HIGGS, Noel John, late of 19 The Avenue, Geelong, who died 19 June 1994.

LOVE, Freda, late of H. L. Williams Court Hostels, 457 Springvale Road, Springvale, who died 6 January 2002.

NEWTON, John Bruce, late of Unit 8, 124 Alma Road, St Kilda East, pensioner, who died 8 April 2002.

RHODE, Harold George, late of 45 Shaftsbury Street, Coburg, retired, who died 17 March 2002.

TALBOT, Ronald, late of 15 Fern Avenue, Windsor, retired, who died 4 May 2002.

TAYLOR, James Gordon, late of 26 Holland Road, Ringwood East, retired, who died 15 March 2002.

TRALLI, Antonio, late of Riverside House, 2 River Street, Richmond, who died 8 March 2002.

WHITE, Elsie Mary, late of John Curtain Memorial Hostel, Cushion Avenue, Creswick, retired, who died 27 February 2002.

Dated at Melbourne, 14 May 2002

LAURIE TAYLOR  
Manager, Estate Management  
State Trustees Limited

---

STATE TRUSTEES LIMITED  
ACN 064 593 148  
Section 79

Notice is hereby given that State Trustees Limited, ACN 064 593 148 intends administering the estates of:-

HERMAN MATTSON, late of Rosanna Views Aged Care Facility, 267-271 Lower Plenty Road, Rosanna, Victoria, retired, deceased intestate, who died 24 March 2002.

KEITH DUDLEY FLEMING, also known as Keith Dudley John Barron Fleming, late of Victoria House, 181 Commercial Road, Koroit, Victoria, retired, deceased, who died 9 March 2002, leaving a will dated 25 January 1940.

Creditors, next-of-kin and others having claims against the abovementioned estates are required pursuant to Section 33 of the **Trustee Act 1958** to send particulars of their claims against the abovementioned estates to State Trustees Limited, 168 Exhibition Street, Melbourne, Victoria, on or before 30 July 2002 after which date State Trustees Limited, ACN 064 593 148, may convey or distribute the assets of the abovementioned estates having regard only to the claims of which it then has notice.

---

STATE TRUSTEES LIMITED  
ACN 064 593 148

Section 79

Notice is hereby given that State Trustees Limited, ACN 064 593 148 intends administering the estates of:-

NOEL WAYNE HOBSON, late of Anchorage Hostel, 81 Victoria Crescent, Abbotsford, Victoria, pensioner, deceased, who died 25 February 2002.

BARRY DAVID BUSWELL, late of Austin and Repatriation Medical Care, Banksia Street, West Heidelberg, Victoria, pensioner, deceased intestate, who died 22 March 2002.

Creditors, next-of-kin and others having claims against the abovementioned estates are required pursuant to Section 33 of the **Trustee Act 1958** to send particulars of their claims against the abovementioned estates to State Trustees Limited, 168 Exhibition Street, Melbourne, Victoria, on or before 2 August 2002 after which date State Trustees Limited, ACN 064 593 148, may convey or distribute the assets of the abovementioned estates having regard only to the claims of which it then has notice.

---

Creditors, next-of-kin and others having claims against the estate of any of the undermentioned deceased persons are required to send particulars of their claims to State Trustees Limited, ACN 064 593 148, 168 Exhibition Street, Melbourne, Victoria 3000, the personal representative, on or before 2 August 2002 after which date State Trustees Limited may convey or distribute the assets having regard only to the claims of which State Trustees Limited then has notice.

COBB, Helen Elizabeth, late of St Benedicts Nursing Home, 5 Heath Street, Sandringham, pensioner, who died 2 March 2002.

HOWARD, Ross William, late of Unit 3, 222 Queens Parade, Clifton Hill, Victoria, pensioner, who died 11 April 2002.

LAMBERT, Ethel May, late of Unit 1, 62-66 Southampton Street, Footscray, home duties, who died 11 May 2002.

MALPAS, Eric, late of Avonsleigh Terrace Hostel, 41-43 Robe Street, St Kilda, retired, who died 14 June 2001.

SCOTT, May Elizabeth, late of Newcomb Nursing Home, 117 Helms Street, Newcomb, pensioner, who died 16 April 2002.

Dated at Melbourne, 24 May 2002

LAURIE TAYLOR  
Manager, Estate Management  
State Trustees Limited

100 and 195 of the **Equal Opportunity Act 1995** to enable the applicant to advertise for and employ a male residential support worker.

This exemption is to remain in force from the day on which notice of the exemption is published in the Government Gazette until 29 May 2005.

Dated 27 May 2002

Mrs CATE McKENZIE  
Deputy President

EXEMPTION

Application No. A136 of 2002

The Victorian Civil and Administrative Tribunal has considered an application pursuant to Section 83 of the **Equal Opportunity Act 1995** by the Victoria Street Program. The application for exemption is to enable the applicant to advertise for and employ a male residential support worker.

Upon reading the material submitted in support of the application the Tribunal is satisfied that it is appropriate to grant an exemption from Sections 13, 100 and 195 of the Act to enable the applicant to advertise for and employ a male residential support worker.

In granting this exemption the Tribunal noted:

- the applicant is a residential rehabilitation program whose purpose is to assist adults in the Western Region with a severe psychiatric disability to live more independently in the environment of their choice;
- there are twenty clients in the program and generally there are more male clients than female. Clients can exhibit difficult challenging behaviours, such as physical and verbal abuse;
- many aspects of the program are directed to the development of very concrete and specific skills, such as personal hygiene and self-care, social skills, budgeting, shopping, cooking and other aspects of daily living skills. It is essential to provide a male role model for both men and women;
- the Victoria Street Program currently has a number of male clients with drug and alcohol issues who can when intoxicated exhibit severe challenging behaviours that threaten the safety of female clients and staff. The presence of a male full-time worker will assist in minimizing and containing these incidents.

The Tribunal hereby grants an exemption to the applicant from the operation of Sections 13,

EXEMPTION

Application No. A145 of 2002

The Victorian Civil and Administrative Tribunal has considered an application pursuant to Section 83 of the **Equal Opportunity Act 1995** by the Belvoir Wodonga Special Development School. The application for exemption is to enable the applicant to advertise for and employ a male teacher.

Upon reading the material submitted in support of the application the Tribunal is satisfied that it is appropriate to grant an exemption from Sections 13, 100 and 195 of the Act to enable the applicant to advertise for and employ a male teacher.

In granting this exemption the Tribunal noted:

- the applicant currently has no male teaching staff;
- the position is required for a group of 11–13 year old students who are aggressive, very strong and extremely challenging. Two of the students frequently abscond and have to be located;
- there have been a significant number of injuries to staff and students and the School Council requires a male teacher to ensure the safety of students and staff.

The Tribunal hereby grants an exemption to the applicant from the operation of Sections 13, 100 and 195 of the **Equal Opportunity Act 1995** to enable the applicant to advertise for and employ a male teacher.

This exemption is to remain in force from the day on which notice of the exemption is published in the Government Gazette until 29 May 2005.

Dated 27 May 2002

Mrs A. COGHLAN  
Deputy President

**Crown Land (Reserves) Act 1978****CROWN LAND RESERVES (LILYDALE TO WARBURTON RAIL TRAIL RESERVE)  
(EXTENSION OF APPLICATION) REGULATIONS 2002**

I, Wayne Malone, Manager Land Victoria, Port Phillip Region, in the Department of Natural Resources and Environment, as delegate of the Minister for Environment and Conservation, make the following Regulations:

1. Title  
These Regulations may be cited as the Crown Land Reserves (Lilydale to Warburton Rail Trail Reserve) (Extension of Application) Regulations 2002.
2. Principle Regulations  
In these Regulations the regulations made on 13 November 1997 and published in the Victoria Government Gazette of 27 November 1997 with respect to the Lilydale to Warburton Rail Trail Reserve are called the Principal Regulations.
3. Authorising provision  
These Regulations are made under section 13 of the **Crown Land (Reserves) Act 1978**.
4. Commencement  
These Regulations come into force on the day that they are published in the Government Gazette.
5. Extension/Application of Principal Regulations  
The Principal Regulations are extended to apply to the Crown Land reserves listed in the Schedule, being reserved land managed by the Committee of Management known as the Lilydale to Warburton Rail Trail Committee of Management Incorporated.

**SCHEDULE****RESERVES TO WHICH THESE REGULATIONS APPLY**

1. LAUNCHING PLACE AND WOORI YALLOCK — 20 hectares, more or less temporarily reserved for Public Purposes (Rail Trail) by Order in Council dated 20 January 1998 and by notice in the Government Gazette of 22 January 1998 p142, being Crown Allotment 1C, Section A, Township of Launching Place and Crown Allotments 40G, 79A, 80A and 52N1, Parish of Woori Yallock as shown on Plan Number LEGL./97-286 and Crown Allotments 42D and 82B, Parish of Woori Yallock as shown on Plan Number LEGL./97-294, both lodged in the Central Plan Office.
2. MOOROOLBARK — 2.428 hectares, more or less temporarily reserved for Public Purposes (Rail Trail) by Order in Council dated 20 January 1998 and by notice in the Government Gazette of 22 January 1998 p142, being Crown Allotment 30A1, Parish of Mooroolbark.
3. WARBURTON — 25 hectares, more or less temporarily reserved for Public Purposes (Rail Trail) by Order in Council dated 20 January 1998 and by notice in the Government Gazette of 22 January 1998 p142, being Crown Allotments 19C and 27C, Section B and Crown Allotments 3A and 6C, No Section, Parish of Warburton as shown on Plan Number LEGL./97-287 and Crown Allotment 13G, Township of Warburton and Crown Allotments 12Q, 12R, 12S, 12T, 14H and 14J, Parish of Warburton as shown on Plan Number LEGL./97-288, both lodged in the Central Plan Office.
4. WOORI YALLOCK — 11 hectares, more or less temporarily reserved for Public Purposes (Rail Trail) by Order in Council dated 2 May 2000 and by notice in the Government Gazette of 4 May 2000 p900, being Crown Allotments 52G1 and 52G2, Parish of Woori Yallock, as shown outlined red on Plan Number LEGL./98-93 lodged in the Central Plan Office.



5. LILYDALE AND YERING — 1.8322 hectares, more or less being portion of the area temporarily reserved for Public Purposes by Order in Council dated 12 December 2000 and by notice in the Government Gazette of 14 December 2000 p2963, being Crown Allotment 10A, Section 11, Township of Lilydale and Crown Allotment 18A, Section 30, Parish of Yering as shown on Plan Number LEGL./00-28 lodged in the Central Plan Office.

Dated 2 May 2002

WWYNE MALONE  
 Manager Land Victoria, Port Phillip Region  
 in the Department of Natural Resources and Environment  
 as delegate for the Hon Sherryl Garbutt  
 Minister for Environment and Conservation

### Gas Industry Act 2001

#### NOTICE OF AMENDMENT UNDER SECTION 52(6) Victorian Gas Industry Market and System Operation Rules (“MSO Rules”)

Pursuant to and in accordance with clause 52(6) of the **Gas Industry Act 2001** VENCORP has resolved to amend the MSO Rules as follows, effective as of 1 June 2002:

Clause 3.6.8(gc) is deleted.

Clause 6.6.4(b) is amended by deleting the word “their” and substituting the word “the” and by adding the words “or *AMDQ credits* assigned to those *Customers*” at the end of the clause.

Clause 11 is amended by deleting the definition of “AMDQ credit” and substituting the new definition as follows:

AMDQ credit	The whole or part of an <i>AMDQ credit nomination</i> that may be applied by the registered holder of the <i>AMDQ credit certificate</i> for the purpose of: <ul style="list-style-type: none"> <li>(a) reducing the amount of <i>uplift payments</i> determined in accordance with clause 3.6.8; or</li> <li>(b) establishing a priority of <i>curtailment</i> of customers in accordance with clause 6.6.4(b).</li> </ul>
-------------	---

### Geographic Place Names Act 1998

#### NOTICE OF REGISTRATION OF GEOGRAPHIC NAMES

The Registrar of Geographic Names hereby gives notice of the registration of amendment of the undermentioned place names.

File No.	Place Names	Proposer & Location
PNC 1425	Parts of St Albans and Deer Park to Cairnlea	Brimbank City Council. As set out on version 4.3 of the plan showing the suburb names and boundaries within the municipality. These plans may be inspected at the municipal offices or at the office of the Registrar of Geographical Names.

Office of the Registrar of Geographic Names  
 C/-LAND VICTORIA,  
 15th Floor,  
 570 Bourke Street,  
 Melbourne 3000

KEITH C. BELL  
 Registrar of Geographic Names

**Geographic Place Names Act 1998**

## NOTICE OF REGISTRATION OF GEOGRAPHIC NAMES

The Registrar of Geographic Names hereby gives notice of the registration of undermentioned place names.

<b>File No.</b>	<b>Place Name</b>	<b>Proposer &amp; Location</b>
GPN 437	Burkes Bridge	Nillumbik Shire. New concrete bridge over Arthurs Creek on the Hurstbridge–Arthurs Creek Road, Hurstbridge.
GPN 443	Historic Burkes Bridge	Nillumbik Shire. Original wooden bridge replaced by new concrete Burkes Bridge over Arthurs Creek on the Hurstbridge–Arthurs Creek Road, Hurstbridge.

Office of the Registrar of Geographic Names  
C/-LAND VICTORIA,  
15th Floor,  
570 Bourke Street,  
Melbourne 3000

KEITH C. BELL  
Registrar of Geographic Names

**Dental Practice Act 1999**

## DENTAL PRACTICE BOARD OF VICTORIA

Dr Leonid Exler of 379 St Kilda Street, Brighton, had his registration suspended from 15 December 2001 until 14 March 2002. This suspension was stayed pending an appeal to VCAT. On withdrawal of this appeal, Dr Exler's registration was suspended from midnight 29 April 2002 until midnight 31 July 2002.

Following a hearing held on 6 days from 10 May 2001 to 10 September 2001, Dr Leonid Exler was found guilty of unprofessional conduct in matters related to advertising, infection control, consent to treatment and breaches of Drugs, Poisons and Controlled Substances Regulations 1995. The Board's panel reprimanded Dr Exler, imposed fines totalling \$34,000 and imposed a condition of regular and random audits by officers of the Board until 14 April 2004.

PETER GARDNER  
Chief Executive Officer

**Associations Incorporation Act 1981**

## NOTICE OF ISSUE OF CERTIFICATE OF INCORPORATION PURSUANT TO SECTION 10 OF THE ASSOCIATIONS INCORPORATION ACT 1981

Notice is hereby given pursuant to Section 10 of the **Associations Incorporation Act 1981** that a certificate of incorporation was issued by the Registrar of Associations on 21 May 2002 to Sherbrook & Pakenham Division of General Practice Incorporated and the Association is now incorporated under the said Act.

Dated at Melbourne 21 May 2002.

PAUL HOPKINS  
Deputy Registrar of Associations

**Associations Incorporation Act 1981**

## SUB-SECTION 36E(5)

Notice is hereby given that the incorporation of the associations mentioned below are cancelled in accordance with Section 36E(5) of the **Associations Incorporation Act 1981**.

Airly/Clydebank Public Hall Inc., Altona City "Tartan Army" Soccer Club Inc., Amani Educational Services Inc., Andersen Consulting Social Club Inc., ANIMA (Arts Network of Information & Mutual Assistance ) Inc., Art Lanka Inc., Association of Russian Speaking Medical Professionals Inc., Australia-Bosnia Business Council Inc., Australia-Chile Business and Investment Council Inc., Australian Computer Museum Society Inc., Australian Croatian Democratic Union Social Inc., Australian Foot & Fist Boxing Association Inc., Australian Green Cleaning Association Inc., Australian Hellenic Centre of Education Inc., Australian Institute of Security Management Inc., Australian Internet User Group Inc., Australian Racing Services Association Inc., Australian Taichi Association Inc., Australian Vegan Society (Victoria) Inc., Australian Vegetarian Society (Victoria) Inc., Australian-Serbian Chamber of Commerce & Industry of Victoria Inc., Ayrshire Cattle Promotions Inc., Bairnsdale Community Club Inc., Ballarat Accommodation Group Inc., Baw Baw Twin Towns Committee Inc., Bellarine Christian Riding Club Inc., Bendigo Jazz Festival Inc., Bendigo Magic Association Inc., Bhuddist C.T. Mercy, Charity & Cultural Association Inc., Blackburn-Hamilton-Shout Streets Roads Group Inc., Broadmeadows Area Family Centre Inc., Bundoora Square Traders Association Inc., Capital 'A' Hockey Club Inc., Caulfield United Panahaiki Soccer Club Inc., Central Association of Melbourne Slotcars Victoria Inc., Centre For Policy Research Inc., Chalcot Lodge Recreation Reserve Committee Inc., Cheltenham Flora & Fauna Reserve Management Committee Inc., Chinese Students Union For Residency Inc., Citizen Advocacy Victoria Inc., Coastal Villages Coast Action Group Westernport Inc., Cockatoo Outreach and Community Care Organisation Inc., Cohuna Ski Club Inc., Collingwood Warriors Soccer Club Inc., Congregational Christian Church in Samoa - Glenroy Parish Inc., Conspiracy Theatre Inc., Criterion Hotel Sporting Club Inc., Crolife Inc., Customer

Contact Management Association Inc., Dallas Traders Association Inc., Darebin Pre-school Association Inc., Develop Dimboola Committee Inc., Diggers Rest Youth Group Inc., Dodos Incognito Theatre Company Inc., Doncaster Raiders Soccer Club Inc., E.C.Y.-Goulburn Valley Inc., Eastern Ranges Football Club Inc., Edbel Nahda Social Club & Benevolent Society Inc., Esther Park Committee of Management Inc., Federation of Central American Organizations (FEDECA) Inc., Fighting Blindness Foundation Inc., Fire and Brimstone Social Club Inc., Firmow Ski Club Inc., Footscray Public Tenants Group Inc., Frankston and District Junior Football League Umpires Association Inc., Friends of Horsham School of Ballet Inc., Gardner Perrott Employees Social Club (Eastern Victoria) Inc., Gastronomic Club Inc., Geelong Musical Theatre Group Inc., Golden Paradise Youth Group Inc., Goulburn Valley Demons Club Inc., Granny Flat Association of Victoria Inc., Greenhill Social Club Inc., Grey Area Art Space Inc., Hayom Inc., Hepat Inc., Hepatitis C Support Group, Hume Region Inc., Highbury Rise Inc., Hybrid Street Hockey League Inc., Institute of Faith and Guidelines, Australia (IFGA) Inc., Inter-Centre For Islamic Visual Communication Inc., International Committee of Lawyers for Tibet-Australia Inc., International Health Spiral Action Network-Ihsan Inc., Islamic Education Society of Australia Inc., Italo Australian Veteran Cycling Club Inc., Jat Inc., Jets Softball Club Inc., Knox Community Action Inc., Labour of Love Association Inc., Laiko Teatro - Thiasos Yianni Chrisouli Inc., Langwarrin Bush and Parklands Group Inc., Lavida Music Inc., Living Lord Gospel Centre Inc., Macedonian Fishing, Shooting and Sporting Club Inc., Macedonian Information Service Association of Australia Inc., Macedonian Senior Citizens Group Zlatno Sonce of Footscray Inc., Magic and Associated Gaming Entity (MAGE) Inc., Mallee Heritage Group Inc., Malvern Central After School Care Inc., Maramba Marvels Netball Club Inc., Maryborough Drive-In Support Committee Inc., Melbourne Islamic Centre Inc., Melbourne Pioneers Womens Rugby Football Club Inc., Melbourne Turkish Businessman Association Inc., Melbourne University Student Union (M.U.S.U.) Radio Collective Inc., Melton

Christian Ministry Centre Inc., Merri Shakespeare Inc., Mimesis Inc., Mixed Company Theatre Inc., Moonee Valley Community Coalition Inc., Moorabool Tourism Promotion Association Inc., Moratuwa Sports Club Inc., Mountain Valley Field Archers Inc., Multicultural Society of Mildura Inc., Murray Valley Engineers Association Inc., Natural Healing Association of Australia (NHAA) Inc., Netconnect Australia Inc., Noojee Parks and Reserves Inc., North East Computer Club Inc., Oaklands Park Equestrian Club Inc., Orana Chamber Orchestra Inc., OROMIYAA Soccer Club Inc., Ozorient Arts Australia Inc., Peechelba Residents Association Inc., Peninsula Caravan Parks Association Inc., Permaculture Global Assistance Network Inc., Peruvian Huacaya and Suri Association Inc., Popozhani Social Club Inc., Portland Bicycle Users Group Inc., Powlett River Downs Campdraft Inc., Professional For Community Service Inc., Rabid-Tales of Love and Fear Inc., Ratuforia Inc., Regional Housing Council Network Inc., Relief and Development Agency Inc., Relief Organization for Ethiopia in Australia Inc., Riviera Gridiron Football Association Inc., Road Trauma Support Team Bendigo Inc., Robinvale Tongan Association Inc., Sango Misiki Inc., Serbian Community Television Inc., Society for Philosophy of Religion and Philosophical Theology Inc., Society of Industrial & Human Science Inc., South East Australian Transport Strategy Inc., Southern Bulls Gridiron Club Inc., Southern Swimming Club Inc., St. Gerard's Singers Inc., St. Kilda South Caulfield Junior Football Club Inc., Strippers and Hookers Social Club Inc., Sunrise 21 Inc., Swan Hill Grubb and Grogg Group Inc., Team Buller Freestyle Australia Inc., Team Good Times Racing Inc., Tele Social Club TSC Inc., The Al-Ehsan Centre Inc., The Australasian College of Massage Practitioners Inc., The Australia-Asia Performing Arts Association Inc., The Australian Aged Care Therapy Association Inc., The Baskerobics Bug Club Inc., The Big Dance Combo Inc., The Clunes District Health Service Inc., The Crossing Community Centre Inc., The Ethnic Women's Association Inc., The Family Law Reform Party Inc., The Macedonian Orthodox Church Community "St. Nikola" Preston Inc., The Magnificent Seven City Arcades Inc., The Mornington Peninsula Burns Club Inc., The

Nepean Angling Society Inc., The Ocean, River and Lake Angling club Inc., The P.L. Williams Club Inc., The Primal Place Association Inc., The Progress Party Inc., The Region X Cultural Association Inc., The Silks and Saddles Club Inc., The Victorian Drug Reform Foundation Inc., The Whalers Inn Social Club Inc., The Wimmera Bands Group Inc., Thomas Hardy Ministries Inc., Timboon Service Club Inc., Tooradin Coast Action Group Inc., Turkish Schools Community of Victoria Inc., UFO Ausnet Organisation Inc., Ukrainian Evangelical Baptist Church Association Inc., United Northern Youth Support Network Inc., United Retailers Association Inc., Victoria Hand Surgery Society Inc., Victorian Aboriginal Tourism Association Inc., Victorian Aboriginal Women's Association Inc., Victorian Chauffeurs Association Inc., Victorian Fujian Chinese Society Inc., Victorian Junior Chess League Inc., Victorian Mental Health Cycle Team Inc., Victorian Sportsclub Fundraising Association Inc., Vietnamese Community in Hume Inc., Village Green Pool Club Inc., Wallan Farmed Game Processing Council Inc., Water Group Social Club Inc., What's New Franchisees Association Inc., White Arc Group Inc., Yarra Ranges Ratepayers Inc., Youth Works Inc.

Dated 30 May 2002

ANN HAMMANN,  
Deputy Registrar of  
Incorporated Associations.

### **Associations Incorporation Act 1981**

#### **SUB-SECTION 36E(5)**

Notice is hereby given that the incorporation of the associations mentioned below are cancelled in accordance with Section 36E(5) of the **Associations Incorporation Act 1981**.

1st Craigieburn Scout Group Committee Inc., A World of Difference Inc., A.7 Rotary Valve Two Stroke Club Inc., Active Contacts For Enterprise Success Business Network Association Inc., Active in Lakes Inc., African Communities Welfare Services Inc., Afrique Noire Inc., Alternative Farming Network Inc., Altona Squash Club Inc., Aqua Blue Social Club Inc., Association of Liberian Community of Australia Inc., Assyrian Church St. Joseph & All Saints Parish Inc., Athletics A.P.S. Inc., Aussie Diamonds Women's Baseball Inc., Australasian

Servants Community Inc., Australia Fujian Chamber of Commerce Inc., Australia-Bosnian Association Inc., Australian African Development Program (AADP) Inc., Australian Carriage (Horse Drawn) Industry Association Inc., Australian Childrens Contact Services Association Inc., Australian College of Spiritualism Inc., Australian Ghanaian Welfare Association Inc., Australian Grass Board Association Inc., Australian Guild of Psychics Inc., Australian Icestock Sport Association Inc., Australian Multicultural Worksearch Association Inc., Australian New Zealand Putian Association Inc., Australian Pighunters Association (APA) Inc., Australian Sommeliers Association Inc., Australian Sporthorse Breeders Association Inc., Australian Takaful Association Inc., Australian Vietnamese Chamber of Commerce & Industry Inc., Australian Vietnamese Health & Retirement Village Inc., Australian-Greeks in Support of the Australian Olympic Team Inc., Australian-Serbian Community of Gippsland Inc., Bairnsdale 8-Ball Association Inc., Banyule Hawthorn Supporters Group Inc., Barwon Regional In-Line Hockey Association Inc., Bass Coast Kidney Care Association Inc., Bayside Lifesaving Club Inc., Black Rock Foreshore Residents Association Inc., Blow Up Theatre Company Inc., Blue Heaven Healing Centre Inc., Brunswick Arabic School Association Inc., Bulleen Traders Association Inc., Burra In-Line Hockey Club Inc., C.O.W.S. Inc., CAERS: Community Advancement Educators, Rehabilitation Specialists Inc., Cambodian-Australian Community Inc., Cann River Junior Football Club Inc., Canon Camera Group Inc., Carrajung Hall & Memorial Park Committee of Management Inc., Carrum Downs Branch Blue Light Disco Inc., Caulfield Cougars Soccer Club Inc., Central Highlands Aids Support Team Inc., Charles Green Recreation Reserve Committee of Management Inc., Chatos Make a Dream Foundation Inc., Chinatown Precinct Association Inc., Chinese Community Health Advisory of Australia Inc., Church Life Consultancy Group Inc., Clayton Fishing Club Victoria Inc., Club 286 Inc., Cockatoo Junior Football Club Inc., Collins Wentworth Members Club Inc., Committee of Organ Donation Awareness (C.O.D.A.) Inc., Community Radio Association Inc., Comunita' Emiliano-Romagnola in Australia Inc., Contemporary Arts Access Studios – Mornington Peninsula Inc., Contemporary Sculptors Association (C.S.A.) Inc., Corpus Christi-Penola Junior Football Club Inc., Council of Vietnamese Culture and Education in Victoria Inc., Cowan Region Inc., Creafield Inc., Crown Hotel Sporting and Recreation Club Inc., Cycle Tours Victoria Inc., Dandenong Turkish Cultural Festival Inc., De La Salle Malvern Fathers' Association Inc., Dharmaraja College Old Boys Union, Australia Inc., Dodge Ram Club of Australia Inc., Doncaster Campus Community Childrens Centre Inc., Eaglenet Inc., East Africa Community Association Inc., Eastern and Central Africa Communities of Victoria Inc., Edenhope Kindergarten Inc., Education Options Association for Adults With Disabilities Inc., Educational Alliance Inc., Elmer Region Inc., El-Said, The Australian Egyptian Charitable Assoc. Inc., Emmanuel Evangelical Church Inc., Employment Services Provider Association Inc., Epping Community Business Association Inc., Equine Dental Association of Australia Inc., Eritrean United Association Group Inc., Esthetics Victoria Inc., Factory Theatre Company Inc., Fairway Netball Club Inc., Family and Friends Social Club Inc., Fast Break Pool Club Inc., Fatt Boys Mountain Bikes Inc., Federazione Calabrese Del Victoria Inc., Fellowship League of Australian Tamils for Cultural Development Inc., Ferrari Owners Club Inc., Ferret Protection and Welfare Society Inc., Filipino Christians Women Foundation Inc., Filipino-Australian Business Association Inc., Four Provinces Gaelic Football Club Inc., Friends of Henrys Creek Sanctuary Inc., Friends of the Canadian Forest Inc., Friends of the Cathedrals 'Clean Up' Group Inc., Friends of Wonthaggi Heathland & Coastal Reserve Inc., Gannawarra Multi Use Shooting Complex Committee Inc., Geelong Accident Allocation Centre Inc., Gippsland Environment Group Inc., Gippsland Research & Information Services Inc., Giraffe Association – Centre for Community Arts Inc., Glen Eira Youth Support Group Inc., Glen Iris Traders & Business Association Inc., Global Trade & Cultural Links Inc., God Is With Us, Evangelical Church Inc., Grampians Street & Custom Car Club Inc., Graytown & District Progress Association Inc., Greek Senior Citizens Club of Casey Inc., Greening Kensington Inc., Greening Melton Inc., Grupo Folklorico Violeta Parra Inc., Halambey Stars Inc., Hanslope Support Group

Inc., Hellenic Film & Television Inc., Heritage Rail Australia Inc., Heywood Advanced Breeders Group Inc., Highlands/Caveat Community Association Inc., Holistic Law Inc., Hook Turn Promotions Inc., Human Values Foundation (Australia) Inc., Humura Inc., Ihya'A E'Sunna Association of Australia Inc., Independent Business and Industry Association of Australia Inc., Indonesian Muslim Community of Victoria Inc., Indonesian–Australian Friendship Club in Geelong Inc., Indoor Rock Climbing Gyms Australia Association Inc., Infexious Entertainment Inc., Institute of Certified Management Accountants Inc., Interfaith Fellowship (Temple of Divine Love) Association Inc., International Winter School For Strings Inc., Internet Brokers Association of Australia Inc., Invergordon Action Group Inc., ITLNET (Information Technology Learning Network) Inc., Japan Down Under Inc., Jells Park Training Consortium Inc., Jennie Gray Foundation of Hope Inc., Justitia Civil Rights Society Inc., Kealba Concerned Citizens Inc., Keech Castings Social Club Inc., Key Alliance Inc., Keysborough Saints Soccer Club Inc., Khyat's Social Golf Club Inc., Kim Quang Charity Centre Inc., Klabouchischa Social Club Inc., Kurdistan Women's League of Australia Inc., La Trobe Union Radio Inc., Latin American Community For Integral Development Inc., Leongatha Sports & Community Club Inc., Lighthouse Theatre Inc., Linc Church Services Network South Whittlesea Inc., Linh Quang Welfare & Charity Association Inc., Listen Up Association Inc., Llave Hispane Community Group Inc., Local Exchange Trading System – Vallets Inc., Loss Inc., Loudmouth Theatre Inc., Lyndale Boys Club Inc., Lysterfield Lake Lifeguards Inc., Mac Promotions Club Inc., Macau Club Inc., Maccabi Kayaking and White Water Rafting Club Inc., Macedon Ranges North Eastern Region Business and Tourism Association Inc., Macedonian Orthodox Community of Geelong, Victoria Inc., Maffra District Farming, Festivals and Promotions Inc., Makedonski Folk Hit Inc., Management Improvement Council of Australia Inc., Maribyrnong – Victory Athletic Club Inc., Marketplace Missions Inc., Maroondah Football Club Inc., Maryvale Reserve Committee of Management Inc., Masthead Literary Arts Magazine Inc., Maverick Arts Inc., Melbourne Tabla Circle Inc., Melbourne World Friendship Association of Fuqing Inc., Meledy Makers Orchestra Melbourne Inc., Melton Supersonics Basketball Club Inc., Meredith Netball Club Inc., Merlynston Creek Environment Group Inc., Metropolitan Express Delivery Industry Association Inc., Microsoft Project User Group Inc., Minyip Tourism Spring Festival Inc., Monash Community Sports and Social Club Inc., Monbulk BMX Club Inc., Moorabbin District Tenants Group Inc., Moorabbin Flyers–The MFS Social Club Inc., Mooroopna Baseball Club Inc., Mornington Angling Club Inc., Mostyn Street, East End Traders Inc., Mt Evelyn Powerful Owl Preservation Inc., Multicultural Organization For Integral Development Inc., National Action Victoria Inc., Ned Kelly Memorial Society Inc., Netbank Engineering Association Inc., New Horizons Community Restoration Inc., New Life Community Church Inc., Newport Sports Club Inc., Nga Tangi A Te Iwi Maori & Pacific Island Culture Club Inc., North Dandenong Hungarian Senior Citizens Club Inc., North Dandenong Old Boys Inc., North East Firearm Owners Shooters Committee Inc., Not For Profit Employment Network (NPEN) Inc., Nottinghill (Tobacco) Social Club Inc., Nova Foundation Inc., O.M. Events Inc., Origin of The Ashes Inc., Original Music Development Inc., Out Cast Theatre Inc., Panathinaikos Supporters Club (PA.LE.FI.P–MELB) Inc., Parent Educators' Association Inc., Parents Support Group 19 Flight Inc., Permaculture Corporation Inc., Phillip Island Community Festival Association Inc., Phoenix Park Playground Inc., Pistons Basketball Club Inc., Playcorp Social Club Inc., Point Leo Coastal Action Group Inc., Pol–Art Melbourne '97 Inc., Police–Lesbian and Gay Liaison Committee Inc., Polish TV Club Inc., Port Melbourne Rugby League Club Inc., Port Phillip Private Hotel Association Inc., Prahran Athletic Club Inc., Preporod Cultural Association of Bosnians in Victoria Inc., Quarry Hill Progress Association Inc., R.Y.O.T. Ministries Inc., Rainbow Downs Sporting Club Inc., Restoration House Inc., Retap Management Committee Inc., Rising Consciousness of the World Foundation Inc., River of Life World Aid Fund Inc., Robinson Oval Committee Inc., Rodfathers Rod & Custom Club Inc., Rodney 1 & 2 P Drainage Group Inc., Roxburgh Park Softball Club Inc., Roxby Action Collective Inc., Royal Hotel Angling Club Inc., Saints

(Sunbury, Victoria) Basketball Club Inc., Saints Past Players Association Inc., Sale Martial Arts Academy Inc., Sale Table Tennis Association Inc., Sandhurst Access Television Inc., Schola Cantorum Inc., Schools Without Fences Inc., SCS Social Club Inc., Serbian Community Radio Inc., Seymour Childcare Centre Inc., Snowy River Country Business Tourism & Community Association Inc., Snowy River Junior Netball Club Inc., Somali Community of Victoria Assoc. Inc., Somali Rahweyn Relief Association of Australia Inc., Somaliland Community of Melbourne Inc., Somerville Basketball Club Inc., South Eastern Touch Association (S.E.T.A.) Inc., Southern Animal Aid Inc., Southern Flatlands Hang Gliding Club Inc., Southern Peninsula Medical Association Inc., Southern Sports Trainers Association Inc., Spirallite Association Inc., Spirit of the Sea Music Festival Inc., Spiritual Horizons Inc., Sri Lanka Aged Care Services Group Inc., St Patrick's Racing Club (Kilmore) Inc., Standing Conference of Educators and Trainers in Counselling and Psychotherapy Inc., Street Rods Unlimited Inc., Stripp Gallery Inc., Sudan Australian Christian Foundation Inc., Supporting People in Recovery in Life Inc., Surfcoast Outrigger Canoe Club Inc., TAA/Australian Airlines 25 Year Club Victorian/Tasmanian Branch Inc., Talk Artists Initiative Inc., Tallangatta Sports Assembly Inc., Tattoo Association of Australia Inc., Team "Psychos" Multi Sports Geelong Inc., The Australian Dingo Club Inc., The Bluff Boardriders Inc., The Chinese Zhejiang Uniting Association of Australia Inc., The Church of Christ Michael Inc., The Elwood Village Traders Association Inc., The Feline Federation of Australia Inc., The Fitzroy Street Area Residents Association Inc., The Gaf-W Social Fishing Club Inc., The Gentlemen's Club Inc., The Guitar Foundation of Australia Inc., The Hassall Family Bicentenary Association Inc., The Hastings Workers Club Inc., The Holy Virgin's Protection Parish Inc., The Homestead Child & Family Centre Inc., The House of Hope Community Centre Inc., The International Energy Research in South-Eastern Suburbs Inc., The Melbourne Nexus Association Inc., The Mindware Exchange Inc., The National Anti Child Exploitation Foundation Inc., The New Earth Party Inc., The Order of the Cross Australia Inc., The Polish Information and Services Centre Inc., The Powerful Name of

Jesus Evengelistic Ministry Inc., The Small Boat Association Inc., The Sri Lanka House Inc., The Tango Association of Australia Inc., The Victoria Follies Inc., The Victorian Lamb Development Team Inc., The Visiting Pets Program Inc., The Whitehorse Housing Organization Inc., The Wodonga Water Polo Club Inc., Timbarra Community Centre Committee of Management Inc., Timorese Women Association in Australia Inc., Togs Theatre Company Inc., Toorak Toddlers Playgroup Inc., Tribe of Judah Motor Cycle Ministries (Australia) Victorian Chapter Inc., Tullamarine Traders Inc., Turkish Link Inc., Twentys Plenty Fishing Club Inc., Ulpan Inc., Underbool Kart Club Inc., Upper Ovens Valley Ratepayers & Residents Association Inc., Veteast Consortium Inc., Victorian Coptic Orthodox Youth Association Inc., Victorian Cultural Community Development Association Inc., Victorian Early Years Foundation Inc., Victorian Emergency Youth Accommodation Network Inc., Victorian Foundation for Ex-Offenders Inc., Victorian Introduction Industry Association Inc., Victorian Trade Efficiency Association Inc., Victorian Travelling Stock Association Inc., Vietnamese Evangelical Church in Australia Inc., Vietnamese Women's Association of Victoria Inc., Voice of the Syrian Arabic Community Melbourne Inc., Wanderers Rock & Roll Club Inc., Waterside Art Workers Inc., Webscape Group Inc., Wedderburn Junior Basketball Association Inc., West Ivanhoe Sporting Club Inc., Western Port Young Mariners Inc., Western Victoria Family Business Network Inc., Western Zone Rock Lobster Association Inc., Westside Gamblers Social Club Inc., Westside Gay & Lesbian Support & Social Group Inc., White Chalk Turkish School Inc., Wodonga and District Community Forum Inc., Wolseley Hornet Special Club of Australia Inc., Women in Motor Sport Association, Wonthaggi Gymnastics Centre Inc., Woodroffe Social Club Inc., Word of Life Inc., Wunta Fiesta Inc., Young Oakleigh Club Inc., Youth For Christ Shepparton Inc.

Dated this 30 May 2002

ANN HAMMANN  
Deputy Registrar of  
Incorporated Associations

**Associations Incorporation Act 1981**

## SUB-SECTION 36E(5)

Notice is hereby given that the incorporation of the associations mentioned below are cancelled in accordance with Section 36E(5) of the **Associations Incorporation Act 1981**.

Ansett Chess Club Inc., Australian Association of Occupational Health & Safety Technologists Inc., Australian Filipino Guidance Association, Australian Mayoral Aviation Council Inc., Australian Philippines Solidarity Movement Inc., Bushcare – Berwick/Pakenham Inc., Cambridge Theatre, City of Hope – Christian Church, Cleaning Employer's Association Inc., Coldfusion Developers Guild, Coolamatong Inc, Dumbalk East Tennis Club Inc., Dunolly BMX Club Inc., East Gippsland Access Project Inc., Friends of Eccles & Napier, Hastings and District Netball Association Inc., Inverloch B.M.X. Club Inc., Journal Community News Arts & Views Around Castlemaine Inc., Keilor Park Community Centre Inc., Lang Lang Pistol Club Inc., Macedonian Song & Music Ensemble "Leto" Inc, Maryborough Music Tuition Scheme Inc., Millewa Community Drainage Group Inc., Niddrie Preschool Inc., Noble Knights Chess Club Inc., Ozmon Australian Lawn Mower Racing Association Inc., Phillip Island Community Youth Club Inc., Quota Club of Chelsea Inc., Quota International of Caulfield Inc., Real Estate Franchisors Association Inc., Rebel Motorcycle Club, South Croydon Badminton Inc., Stawell & District Traders & Industry Association Inc., Tenants Information and Advice Service, The Box Hill Women's Football Club Inc., The Temy Basketball Club, Wellington B.M.X. Club Inc., West Gippsland Relief Milkers Group Inc., Yarra Canoe Club Inc.

ANN HAMMANN,  
Deputy Registrar of  
Incorporated Associations.

**Drugs, Poisons and Controlled Substances Act 1981**

## SECTION 12G and 12K

Notice Regarding the Amendment,  
Commencement and Availability of the  
Poisons Code

I, John Thwaites, Minister for Health, give notice that the Poisons Code, prepared under

sections 12 and 12E of the **Drugs, Poisons and Controlled Substances Act 1981**, will be amended by incorporating by reference amendments to the Commonwealth standard as prescribed by the Drugs, Poisons and Controlled Substances (Commonwealth Standard) Regulations 2001.

The Poisons Code is a document that enables certain parts of the Commonwealth standard, particularly those parts relating to the uniform scheduling, labelling and advertising of drugs and poisons, to be incorporated by reference and then applied as law in Victoria.

The Poisons Code will be amended to the extent that earlier incorporated by reference material, being the Standard for the Uniform Scheduling of Drugs and Poisons (SUSDP) No. 16, as amended by SUSDP No. 16, as amended by SUSDP No. 16 Amendments Nos. 1, 2 and 3, will be amended, varied, remade or superseded to the extent necessary by the incorporation by reference of SUSDP No. 16 Amendment No. 4.

The date fixed for the amending, varying, remaking or superseding material to take effect is 1 June 2002.

The Poisons Code may be inspected free of charge during normal business hours at the offices of the Department of Human Services situated at Level 16, 120 Spencer Street, Melbourne 3000. Contact – Duty Pharmacist, Drugs and Poisons Unit, Telephone 1300 364 545 or Level 14, 555 Collins Street, Melbourne 3000. Contact – Legislation Officer, Telephone 9616 7167. A copy of the Poisons Code may also be obtained from the Department or at [www.dhs.vic.gov.au/phd/0003112/index.htm](http://www.dhs.vic.gov.au/phd/0003112/index.htm).

A copy of the Standard for the Uniform Scheduling of Drugs and Poisons, including amendments, may be obtained from the Australian Government Bookshop situated at 190 Queen Street, Melbourne 3000. Telephone 132447.

Dated 15 May 2002

JOHN THWAITES  
Minister for Health

**Environment Effects Act 1978**

## NOTICE UNDER SECTION 3(1)

The Minister for Planning, being satisfied that works proposed in relation to the deepening of Port Phillip Bay shipping channels, could



reasonably be considered to have or capable of having a significant effect on the environment, has declared the works as public works to which the **Environment Effects Act 1978** applies.

PAUL JEROME  
Executive Director  
Planning, Heritage and  
Building Division  
Department of Infrastructure

**Health Services Act 1988**

DECLARATION OF APPROVED  
QUALITY ASSURANCE BODY

I declare the Mortality Review Committee, established by Peninsula Health, is an approved quality assurance body under Section 139 for the purposes of part 7 of the **Health Services Act 1988**.

Dated 10 May 2002

JOHN THWAITES  
Minister for Health

**Land Acquisition and Compensation Act 1986**

FORM 7 S.21  
Reg.16

Notice of Acquisition

Compulsory Acquisition of Interest in Land

The Roads Corporation (VicRoads), declares that by this notice it acquires the following interest in the land described as the whole of Lot 114 on Plan of Subdivision 10507, Parish of Ringwood comprising 702.4 square metres and being land described in Certificate of Title Volume 6054, Folio 691, shown as Parcel 72 on Survey Plan 17976.

**Interest Acquired:** That of Doreen Fidelis O'Brien and all other interests.

Published with the authority of VicRoads.

The Survey plan referred to in this notice may be viewed without charge at the office of Property Services Department, VicRoads, 4th Floor, North Building, 60 Denmark Street, Kew during the hours 9.00 am to 4.00 pm.

Dated 30 May 2002

For and on behalf of VicRoads:  
GERRY TURNER,  
Manager Property Services Department

**Land Acquisition and Compensation Act 1986**

FORM 7 S.21  
Reg.16

Notice of Acquisition

Compulsory Acquisition of Interest in Land

The Roads Corporation (VicRoads), declares that by this notice it acquires the following interest in the land described as part of Lot 189 on Plan of Subdivision 10506, Parish of Ringwood comprising 193.2 square metres and being land described in Certificate of Title Volume 7163, Folio 581, shown as Parcel 87 on Survey Plan 17976.

**Interest Acquired:** That of Hung Thanh Le and Vui Xuan Thi Nguyen and all other interests.

Published with the authority of VicRoads.

The Survey plan referred to in this notice may be viewed without charge at the office of Property Services Department, VicRoads, 4th Floor, North Building, 60 Denmark Street, Kew during the hours 9.00 am to 4.00 pm.

Dated 30 May 2002

For and on behalf of VicRoads:

GERRY TURNER,  
Manager Property Services Department

**Land Acquisition and Compensation Act 1986**

FORM 7 S.21  
Reg. 16

Notice of Acquisition

Compulsory Acquisition of Interest in Land

The Roads Corporation (VicRoads), declares that by this notice it acquires the following interest in the land described as part of Lot 1 on Title Plan 371284W and part of Lot 1 on Title Plan 389481U Parish of Elphinstone comprising 1.5999 hectares, being the land described in Certificate of Title Volume 6343, Folio 512 and Certificate of Title Volume 6343, Folio 514, shown as Parcels 617, 618, 619, 620, on Survey Plan 20306.

**Interest Acquired:** That of Geoffrey Oliver Murray and all other interests.

Published with the authority of VicRoads.

The Survey plan referred to in this notice may be viewed without charge at the office of Property Services Department, VicRoads,

4th Floor, North Building, 60 Denmark Street,  
Kew during the hours 9.00 am to 4.00 pm.

Dated 30 May 2002

For and on behalf of VicRoads:  
GERRY TURNER,  
Manager Property Services Department

---

**Land Acquisition and Compensation Act 1986**

FORM 7 S.21  
Reg.16

Notice of Acquisition

Compulsory Acquisition of Interest in Land

The Roads Corporation (VicRoads), declares that by this notice it acquires the following interest in the land described as part of Crown Allotments 32E & 32F, Section 1, Parish of Elphinstone comprising 6274 square metres and being land described in Certificates of Title Volume 9843, Folio 052 and Volume 10427, Folio 852, shown as Parcels 540 & 542 on Survey Plan 20302A.

**Interest Acquired:** That of Neville Dean Gibbs & Maria Victoria Adelaide Gibbs and all other interests.

Published with the authority of VicRoads.

The Survey plan referred to in this notice may be viewed without charge at the office of Property Services Department, VicRoads, 4th Floor, North Building, 60 Denmark Street, Kew during the hours 9.00 am to 4.00 pm.

Dated 30 May 2002

For and on behalf of VicRoads:  
GERRY TURNER,  
Manager Property Services Department

---

**Land Acquisition and Compensation Act 1986**

FORM 7 S.21  
Reg.16

Notice of Acquisition

Compulsory Acquisition of Interest in Land

The Roads Corporation (VicRoads) declares that by this notice it acquires the following interest in the land described as part of Lots 1 & 2 on Plan of Subdivision 316252L and part of Lot 3 on Plan of Subdivision 316254G, Parish of Lauriston comprising 4.456 hectares and being land described in Certificates of Title Volume 10267, Folios 132 & 133 and Certificate of Title Volume 10356, Folio 245, shown as Parcels 10 and 11 on Survey Plan 20312 and Parcel 52 on Survey Plan 20314.

**Interest Acquired:** That of Betty June Ward and all other interests.

Published with the authority of VicRoads.

The Survey plan referred to in this notice may be viewed without charge at the office of Property Services Department, VicRoads, 4th Floor, North Building, 60 Denmark Street, Kew during the hours 9.00 am to 4.00 pm.

Dated 30 May 2002

For and on behalf of VicRoads:  
GERRY TURNER,  
Manager Property Services Department

---

**Land Acquisition and Compensation Act 1986**

FORM 7 S.21  
Reg.16

Notice of Acquisition

Compulsory Acquisition of Interest in Land

The Roads Corporation (VicRoads) declares that by this notice it acquires the following interest in the land described as part of Lot 2 on Plan of Subdivision 146455, Parish of Elphinstone comprising 834 square metres and being land described in Certificate of Title Volume 9582, Folio 647, shown as Parcel 571 on Survey Plan 20303.

**Interest Acquired:** That of Alan John Burke and all other interests.

Published with the authority of VicRoads.

The Survey plan referred to in this notice may be viewed without charge at the office of Property Services Department, VicRoads, 4th Floor, North Building, 60 Denmark Street, Kew during the hours 9.00 am to 4.00 pm.

Dated 30 May 2002

For and on behalf of VicRoads:  
GERRY TURNER,  
Manager Property Services Department

---

**Land Acquisition and Compensation Act 1986**

FORM 7 S.21  
Reg.16

Notice of Acquisition

Compulsory Acquisition of Interest in Land

The Roads Corporation (VicRoads) declares that by this notice it acquires the following interest in the land described as part of Lots 1 &

2 on Plan of Subdivision 314107G, parish of Lauriston comprising 5811 square metres and being land described in Certificates of Title Volume 10069, Folios 222 & 223, shown as Parcels 32 and 33 on Survey Plan 20313.

**Interest Acquired:** That of Mary Patricia Donovan and all other interests.

Published with the authority of VicRoads.

The Survey plan referred to in this notice may be viewed without charge at the office of Property Services Department, VicRoads, 4th Floor, North Building, 60 Denmark Street, Kew during the hours 9.00 am to 4.00 pm.

Dated 30 May 2002

For and on behalf of VicRoads:  
GERRY TURNER,  
Manager Property Services Department

---

**Land Acquisition and Compensation Act 1986**

FORM 7 S.21  
Reg.16

Notice of Acquisition

Compulsory Acquisition of Interest in Land

The Roads Corporation (VicRoads) declares that by this notice it acquires the following interest in the land described as part of Lot 2, 4 on Title Plan 12293C, Parish of Lauriston comprising 3.447 hectares, being the land described in Certificate of Title Volume 10424, Folio 506 and Certificate of Title Volume 10424, Folio 508, shown as Parcels 30 and 31 on Survey Plan 20313.

**Interest Acquired:** That of Lynette Margaret Matthews and all other interests.

Published with the authority of VicRoads.

The Survey plan referred to in this notice may be viewed without charge at the office of Property Services Department, VicRoads, 4th Floor, North Building, 60 Denmark Street, Kew during the hours 9.00 am to 4.00 pm.

Dated 30 May 2002

For and on behalf of VicRoads:  
GERRY TURNER,  
Manager Property Services Department

---

**Land Acquisition and Compensation Act 1986**

FORM 7 S.21  
Reg.16

Notice of Acquisition

Compulsory Acquisition of Interest in Land

The Roads Corporation (VicRoads) declares that by this notice it acquires the following interest in the land described as part of Crown Portions 25 & 34, Parish of Edgcombe comprising 13.98 hectares being land described in Certificate of Title Volume 0927, Folio 259, shown as Parcels 100 and 101 on Survey Plan 20317.

**Interest Acquired:** That of Sandhurst and Northern District Trustees, ACN 004 030 737 and all other interests.

Published with the authority of VicRoads.

The Survey plan referred to in this notice may be viewed without charge at the office of Property Services Department, VicRoads, 4th Floor, North Building, 60 Denmark Street, Kew during the hours 9.00 am to 4.00 pm.

Dated 30 May 2002

For and on behalf of VicRoads:  
GERRY TURNER,  
Manager Property Services Department

---

**Water Act 1989**

SOUTH WEST WATER AUTHORITY

Notice of Creation of  
Peterborough Sewerage District

Notice is hereby given that, under the provisions of Section 96(7) of the **Water Act 1989** the South West Water Authority proposes to create a new sewerage district to be known as the "Peterborough Sewerage District".

The South West Water Authority has developed a timetable for proceeding with a sewerage scheme for the township of Peterborough over the next three years. An essential first step is the formal establishment of a Sewerage District for the town. A district declares and defines the area of likely planning and system installation but does not necessarily coincide with the boundary of a future sewerage scheme.

Members of the public are invited to make submissions on the proposal. Any person making an objection to the proposal should set out the grounds for any objections raised in the submission.

All submissions received will be considered and assessed by South West Water Authority and the Minister for Natural Resources.

Details of the proposal and a copy of a plan showing the extent of the proposed new Sewerage District are available for inspection at the following places:

- South West Water Authority Offices, 99 Fairy Street, Warrnambool. Phone 55647600;
- General Store-Post Office, 15 Mac Street, Peterborough.

Submissions on the proposal should be submitted in writing to the Chief Executive Officer, South West Water Authority, PO Box 1158, Warrnambool 3280 and received by the Authority before Monday 1 July 2002

RUSSELL WORLAND  
Chief Executive Officer



**Water Act 1989**

CENTRAL GIPPSLAND REGION WATER AUTHORITY (T/A GIPPSLAND WATER)

Proposed New Sewerage District at Seaspray

Notice is hereby given that, under the provisions of Section 96(7) of the **Water Act 1989**, Central Gippsland Region Water Authority proposes to create a new Sewerage District at Seaspray to include parts of the Township of Seaspray in the Parish of Giffard in the County of Buln Buln in the Wellington Shire.

The proposed new Sewerage District is required in anticipation of a wastewater collection scheme being implemented in the next twelve months.

Full details of the proposal and a copy of a plan showing the extent of the new Sewerage District are available for inspection, free of charge, at the office of Gippsland Water, Hazelwood Road, Traralgon, during office hours.

Members of the public are invited to make submissions on the proposal. Any person making an objection to the proposal should set out the grounds for any objections raised in the submission.

Submissions must be received by the Authority by Friday 28 June 2002 and should be addressed to Mr John Mitchell, Chief Executive Officer, Gippsland Water, PO Box 348, Traralgon 3844.

All submissions received will be considered by Gippsland Water and forwarded to the Minister for Natural Resources.

The plan hereunder indicates the boundaries of the proposed new Sewerage District.

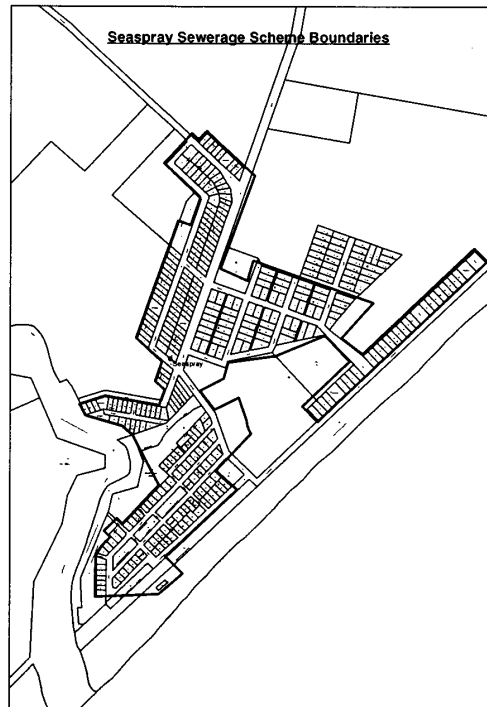

**Water Act 1989**

GOULBURN BROKEN CATCHMENT MANAGEMENT AUTHORITY

Pursuant to section 203 of the **Water Act 1989**, notice is hereby given that the Goulburn Broken Catchment Management Authority intends to declare flood levels for Seymour as shown on Plan No. 540220. These flood levels will be used for planning and building purposes and are based on the Goulburn Broken Catchment Management Authority's best estimate of a flood event which has a probability occurrence of 1% in any one year. This information has been derived from the Seymour

Floodplain Mapping Study prepared for the Eildon to Seymour Flood Warning Group by WMN Oceanics Australia.

The flood level plan (and associated report "Seymour Floodplain Mapping Study") is available for inspection at the Seymour Library, 125 Anzac Avenue, Seymour or the Goulburn Broken Catchment Management Authority Offices, Suite 4, 55 Welsford Street, Shepparton.

Prior to declaring flood levels for Seymour, the Goulburn Broken Catchment Management Authority is seeking submissions from any person within 6 weeks from the date of this notice. In the meantime persons may contact Guy Tierney or Lou Torelli on (03) 5822 2288 to discuss the intention of declaring flood levels. Written submissions should be sent to the Chief Executive Officer, Goulburn Broken Catchment Management Authority, PO Box 1752, Shepparton 3632.

W. J. O'KANE  
Chief Executive Officer

#### **Prevention of Cruelty to Animals Act 1986**

##### APPOINTMENT OF AUTHORISED OFFICERS

I, Peter John Bailey, Director Quality Assurance in the Department of Natural Resources and Environment, pursuant to the powers, duties and functions given to me by a delegation under Section 38 of the **Prevention of Cruelty to Animals Act 1986** and of my respective powers to appoint authorised officers under Section 35 of the **Prevention of Cruelty to Animals Act 1986**, HEREBY APPOINT the following officers as authorised officers for the purposes of Part 2 of the **Prevention of Cruelty to Animals Act 1986**.

<b>Name of Officer</b>	<b>Position of Officer</b>
Louise Rebecca FLINKER	514311
Rebecca Jane MANSBRIDGE	5695
Alisa Jane HECK	6029
Martin James ROCHE	1399

Dated 13 May 2002

PETER JOHN BAILEY  
Director Quality Assurance

#### **Subordinate Legislation Act 1994**

##### NOTICE OF DECISION

##### Health Records Regulations 2002

I, John Thwaites, Minister for Health, give notice under Section 12 of the **Subordinate Legislation Act 1994** as follows:

1. the proposed Health Records Regulations have been the subject of a regulatory impact statement. Public comments and submissions were invited and received and considered in accordance with section 11 of the Act;
2. I have decided to proceed with the making of the proposed Health Records Regulations with amendment.

Dated 30 May 2002

JOHN THWAITES  
Minister for Health

#### **Planning and Environment Act 1987**

##### GREATER GEELONG PLANNING SCHEME

##### Notice of Approval of Amendment

##### Amendment C47

The Minister for Planning has approved Amendment C47 to the Greater Geelong Planning Scheme.

The Amendment comes into operation on the date this notice is published in the Government Gazette.

The Amendment alters planning scheme maps and the schedule to the Heritage Overlay so that two heritage places are shown in the Greater Geelong Planning Scheme consistent with the Victorian Heritage Register.

A copy of the Amendment can be inspected, free of charge, during office hours, at the Department of Infrastructure, Planning Information Centre, Upper Plaza, Nauru House, 80 Collins Street, Melbourne and at the offices of the City of Greater Geelong Council, Ground Floor, 131 Myers Street, Geelong.

PAUL JEROME  
Executive Director  
Planning, Heritage and  
Building Division  
Department of Infrastructure

**Planning and Environment Act 1987**  
GREATER GEELONG PLANNING SCHEME

Notice of Approval of Amendment  
Amendment C51

The Minister for Planning has approved Amendment C51 to the Greater Geelong Planning Scheme.

The Amendment comes into operation on the date this notice is published in the Government Gazette.

The Amendment extends the expiry date of an interim provision that generates a permit requirement for the extension or construction of a dwelling that is higher than 7.5 metres above natural ground level in the Residential 1, Residential 2, Low Density Residential, Mixed Use and Township Zones.

A copy of the Amendment can be inspected, free of charge, during office hours, at the Department of Infrastructure, Planning Information Centre, Upper Plaza, Nauru House, 80 Collins Street, Melbourne and at the offices of the City of Greater Geelong, 131 Myers Street, Geelong.

PAUL JEROME  
Executive Director  
Planning, Heritage and  
Building Division  
Department of Infrastructure

---

**Planning and Environment Act 1987**

KNOX PLANNING SCHEME

Notice of Approval of Amendment  
Amendment C9

The Minister for Planning has approved Amendment C9 to the Knox Planning Scheme.

The Amendment comes into operation on the date this notice is published in the Government Gazette.

The Amendment applies a Development Plan Overlay to land known as Lot 10 Henderson Road, Rowville.

A copy of the Amendment can be inspected, free of charge, during office hours, at the Department of Infrastructure, Planning Information Centre, Upper Plaza, Nauru House, 80 Collins Street, Melbourne and at the offices

of the Knox City Council, Civic Centre, 511 Burwood Highway, Wantirna South.

PAUL JEROME  
Executive Director  
Planning, Heritage and  
Building Division  
Department of Infrastructure

---

**Planning and Environment Act 1987**

MARIBYRNONG PLANNING SCHEME

Notice of Approval of Amendment  
Amendment C28

The Minister for Planning has approved Amendment C28 to the Maribyrnong Planning Scheme.

The Amendment comes into operation on the date this notice is published in the Government Gazette.

The Amendment includes the Gordon Street Baptist Church at 71A Gordon Street, Footscray in a Heritage Overlay on an interim basis.

The Amendment also makes corrections to the reference to 2 Banool Avenue, Yarraville and 1-3 Fehon Street, Yarraville in the Schedule to the Heritage Overlay.

A copy of the Amendment can be inspected, free of charge, during office hours, at the Department of Infrastructure, Planning Information Centre, Upper Plaza, Nauru House, 80 Collins Street, Melbourne and at the offices of the Maribyrnong City Council, corner Hyde and Napier Streets, Footscray.

PAUL JEROME  
Executive Director  
Planning, Heritage and  
Building Division  
Department of Infrastructure

---

**Planning and Environment Act 1987**

MELTON PLANNING SCHEME

Notice of Approval of Amendment  
Amendment C20

The Minister for Planning has approved Amendment C20 to the Melton Planning Scheme.

The Amendment comes into operation on the date this notice is published in the Government Gazette.

The Amendment:

- rezones approximately 800 hectares of land to the north of Springhill Road, west of the Werribee River and south of Exford Road from Rural Zone and Environmental Rural Zone to Mixed Use Zone;
- includes the same approximately 800 hectares of land to the north of Springhill Road in a Development Plan Overlay to provide control over detailed planning of Eynesbury Township;
- includes all the rural land within Eynesbury Station (approximately 2500 hectares) in a Design and Development Overlay to maintain and enhance agricultural productivity;
- includes all the land within Eynesbury Station in an Incorporated Plan Overlay to ensure consolidation of Eynesbury Station into three key holdings and limit the extent of housing development;
- inserts an Eynesbury Station Policy into the Melton Planning Scheme.

A copy of the amendment can be inspected, free of charge, during office hours, at the Department of Infrastructure, Planning Information Centre, Upper Plaza, Nauru House, 80 Collins Street, Melbourne and at the offices of the Melton City Council, High Street, Melton.

PAUL JEROME  
Executive Director  
Planning, Heritage and  
Building Division  
Department of Infrastructure

---

**Planning and Environment Act 1987**

**MOONEE VALLEY PLANNING SCHEME**

Notice of Approval of Amendment

Amendment C18

The Minister for Planning has approved Amendment C18 to the Moonee Valley Planning Scheme.

The Amendment comes into operation on the date this notice is published in the Government Gazette.

The Amendment introduces the Melbourne Airport Environs Policy to the Local Policy Framework.

A copy of the Amendment and permit can be inspected, free of charge, during office hours, at the Department of Infrastructure, Planning Information Centre, Upper Plaza, Nauru House, 80 Collins Street, Melbourne and at the offices of Moonee Valley City Council, 9 Kellaway Avenue, Moonee Ponds.

PAUL JEROME  
Executive Director  
Planning, Heritage and  
Building Division  
Department of Infrastructure

---

**Planning and Environment Act 1987**

**MOONEE VALLEY PLANNING SCHEME**

Notice of Approval of Amendment

Amendment C29

The Minister for Planning has approved Amendment C29 to the Moonee Valley Planning Scheme.

The Amendment comes into operation on the date this notice is published in the Government Gazette.

The Amendment:

- introduces heritage controls to four (4) buildings and structures throughout the municipality; and
- corrects an anomaly in the reference numbers in the Heritage Overlay Schedule that applies to land at 18 Woods Street, adjoining the south side of the Maribyrnong River.

A copy of the Amendment can be inspected, free of charge, during office hours, at the Department of Infrastructure, Planning Information Centre, Upper Plaza, Nauru House, 80 Collins Street, Melbourne and at the offices of the Moonee Valley City Council, 9 Kellaway Avenue, Moonee Ponds.

PAUL JEROME  
Executive Director  
Planning, Heritage and  
Building Division  
Department of Infrastructure

---

**Planning and Environment Act 1987**  
**MORELAND PLANNING SCHEME**

Notice of Approval of Amendment  
 Amendment C1 Part 2

The Minister for Planning has approved Amendment C1 Part 2 to the Moreland Planning Scheme.

The Amendment comes into operation on the date this notice is published in the Government Gazette.

The Amendment applies to land comprising approximately 1,725 square metres and located at 22 French Avenue, Brunswick East. It rezones part of the land comprising approximately 1,500 square metres from Business 3 Zone to Residential 1 Zone and includes all the land within the Design and Development Overlay.

A copy of the Amendment can be inspected, free of charge, during office hours, at the Department of Infrastructure, Planning Information Centre, Upper Plaza, Nauru House, 80 Collins Street, Melbourne and at the offices of the Moreland City Council, 90 Bell Street, Coburg.

PAUL JEROME  
 Executive Director  
 Planning, Heritage and  
 Building Division  
 Department of Infrastructure

**Planning and Environment Act 1987**  
**STONNINGTON PLANNING SCHEME**  
 Notice of Approval of Amendment  
 Amendment C21

The Minister for Planning has approved Amendment C21 to the Stonnington Planning Scheme.

The Amendment comes into operation on the date this notice is published in the Government Gazette.

The Amendment rezones land at 1 Kingsway, Armadale from a Residential 1 Zone to a Business 2 Zone.

The Minister has granted the following permit under Division 5 Part 4 of the Act: Permit No: 1164/01.

Description of land: 1 Kingsway, Armadale, being all land described as Lot 2 and part of

Common Property, Plan of Subdivision PS 313265 S, Parent Title Volume 03163 Folio 593.

A copy of the Amendment and the planning permit can be inspected, free of charge, during office hours at the office of the planning authority: Stonnington City Council, Planning Counter, Prahran Centre, Prahran Town Hall, corner of Greville and Chapel Streets, Prahran and the Department of Infrastructure, Customer Service Centre, Upper Plaza, Nauru House, 80 Collins Street, Melbourne.

PAUL JEROME  
 Executive Director  
 Planning, Heritage and  
 Building Division  
 Department of Infrastructure

**Planning and Environment Act 1987**  
**WANGARATTA PLANNING SCHEME**

Notice of Approval of Amendment  
 Amendment C8

The Minister for Planning has approved Amendment C8 to the Wangaratta Planning Scheme.

The Amendment comes into operation on the date this notice is published in the Government Gazette.

The Amendment introduces a revised Municipal Strategic Statement (MSS) as well as introducing a number of new and revised local planning policies. The new policies are:

- 22.02 North Wangaratta Industrial Policy;
- 22.04 Small Lot Policy (replaces Excision of a Lot for an Existing Dwelling Policy and Boundary Realignment Policy);
- 22.05 Rural Dwellings Policy (replaces Dwellings in Rural Zones Policy);
- 22.06 Licensed Premises Policy;
- 22.07 Central Activities Area Car Parking Policy;
- 22.08 Medical Centres Policy;
- 22.09 Wineries (Cellar Door Sales) Policy.

A copy of the Amendment can be inspected, free of charge, during office hours, at the Department of Infrastructure, Planning Information Centre, Upper Plaza, Nauru House, 80 Collins Street, Melbourne; North Eastern



Regional Office 50–52 Clarke Street, Benalla  
and at the offices of the Wangaratta City  
Council, 64–68 Ovens Street, Wangaratta.

PAUL JEROME  
Executive Director  
Planning, Heritage and  
Building Division  
Department of Infrastructure

---

**Planning and Environment Act 1987**

WANGARATTA PLANNING SCHEME

Notice of Approval of Amendment  
Amendment C9 Part 1

The Minister for Planning has approved  
Amendment C9 Part 1 to the Wangaratta  
Planning Scheme.

The Amendment comes into operation on the  
date this notice is published in the Government  
Gazette.

The Amendment C9 Part 1 introduces two  
new local policies. These provide specific  
guidance for the use and development of land,  
both north and south of the Ovens River in the  
vicinity of Faithfull Street and Apex Park.

It rezones land on the north eastern side of  
Faithfull Street, south-west of the Ovens River,  
between Ovens Street and Murphy Street from a  
Business 2 Zone to a Business 1 Zone.

And it includes all of the land along the north  
eastern side of Faithfull Street, south-west of the  
Ovens River, between Ovens Street and Murphy  
Street, in a Design and Development Overlay to  
enable specific design and built form objectives  
to be translated into planning controls.

A copy of the Amendment can be inspected,  
free of charge, during office hours, at the  
Department of Infrastructure, Planning  
Information Centre, Upper Plaza, Nauru House,  
80 Collins Street, Melbourne and the North  
Eastern regional Office 50–52 Clarke Street,  
Benalla and at the offices of the Wangaratta  
Rural City Council, 64–68 Ovens Street,  
Wangaratta.

PAUL JEROME  
Executive Director  
Planning, Heritage and  
Building Division  
Department of Infrastructure

---

**Planning and Environment Act 1987**

WODONGA PLANNING SCHEME

Notice of Approval of Amendment  
Amendment C8

The Minister for Planning has approved  
Amendment C8 to the Wodonga Planning  
Scheme.

The Amendment comes into operation on the  
date this notice is published in the Government  
Gazette.

The Amendment modifies various planning  
scheme maps to correct a number of anomalies  
and mapping errors, that have come to light  
since the introduction of the new format  
planning scheme.

Correct minor typographical, numerical and  
numbering errors in Local Planning Policies,  
Overlays and Schedules.

A copy of the Amendment can be inspected,  
free of charge, during office hours, at the  
Department of Infrastructure, Planning  
Information Centre, Upper Plaza, Nauru House,  
80 Collins Street, Melbourne, The North Eastern  
Regional Office 50–52 Clarke Street Benalla  
and at the offices of the Wodonga City Council,  
Hovell Street, Wodonga.

PAUL JEROME  
Executive Director  
Planning, Heritage and  
Building Division  
Department of Infrastructure

---

**Planning and Environment Act 1987**

WYNDHAM PLANNING SCHEME

Notice of Approval of Amendment  
Amendment C20

The Minister for Planning has approved  
Amendment C20 to the Wyndham Planning  
Scheme.

The Amendment comes into operation on the  
date this notice is published in the Government  
Gazette.

The Amendment:

- rezones approximately 440 hectares of land  
to the south of Springhill Road, west of the  
Werribee River and north of Ballan Road  
from Rural Zone to Mixed Use Zone;

- includes the same approximately 440 hectares of land to the south of Springhill Road in a Development Plan Overlay to provide control over detailed planning of Eynesbury Township;
- includes all the rural land within Eynesbury Station (approximately 3150 hectares) in a Design and Development Overlay 4 to maintain and enhance agricultural productivity;
- includes all the land within Eynesbury Station in an Incorporated Plan Overlay to ensure consolidation of Eynesbury Station into two key holdings and limit the extent of housing development;
- inserts into the Local Planning Policy Framework:
  - Provision for integrated residential and recreational development at Eynesbury Station;
  - Capitalisation of the assets at Eynesbury Station for recreational and leisure activities;
  - Implementation of the Eynesbury Station Policy to provide for protection of environmental assets;
  - Capitalisation on the environmental and heritage assets of Eynesbury Station;
  - Facilitation of the diversification and intensification of agriculture at Eynesbury Station.
- inserts an Eynesbury Station Policy into the Wyndham Planning Scheme.

A copy of the Amendment can be inspected, free of charge, during office hours, at the Department of Infrastructure, Planning Information Centre, Upper Plaza, Nauru House, 80 Collins Street, Melbourne and at the offices of the Wyndham City Council, Princes Highway, Werribee.

PAUL JEROME  
Executive Director  
Planning, Heritage and  
Building Division  
Department of Infrastructure

The Amendment proposed to rezone land on the eastern side of Armstrong Street described as Lots 1 – 5 on LP 18430, Lot 1 on 91455, Lot 3 on PS 314703 and Part CA 1, Sec 77, Parish of Euroa from Rural Zone to Residential 1 Zone.

The Amendment lapsed on 16 April 2002.

PAUL JEROME  
Executive Director  
Planning, Heritage and  
Building Division  
Department of Infrastructure

---

**Planning and Environment Act 1987**  
STRATHBOGIE PLANNING SCHEME  
Notice of Lapsing of Amendment  
Amendment C6

The Shire of Strathbogie has resolved to abandon Amendment C6 to the Strathbogie Planning Scheme.

**ORDERS IN COUNCIL**

**Casino Control Act 1991**

CLOSURE OF PART OF A ROAD IN THE MELBOURNE CASINO AREA

Order in Council

The Governor in Council acting under section 128L(1) of the **Casino Control Act 1991** closes the part of the road being Crown Allotment 38A Parish of Melbourne South on OP 121285, known as Whiteman Street, South Melbourne, as indicated by hatching on the plan hereunder:

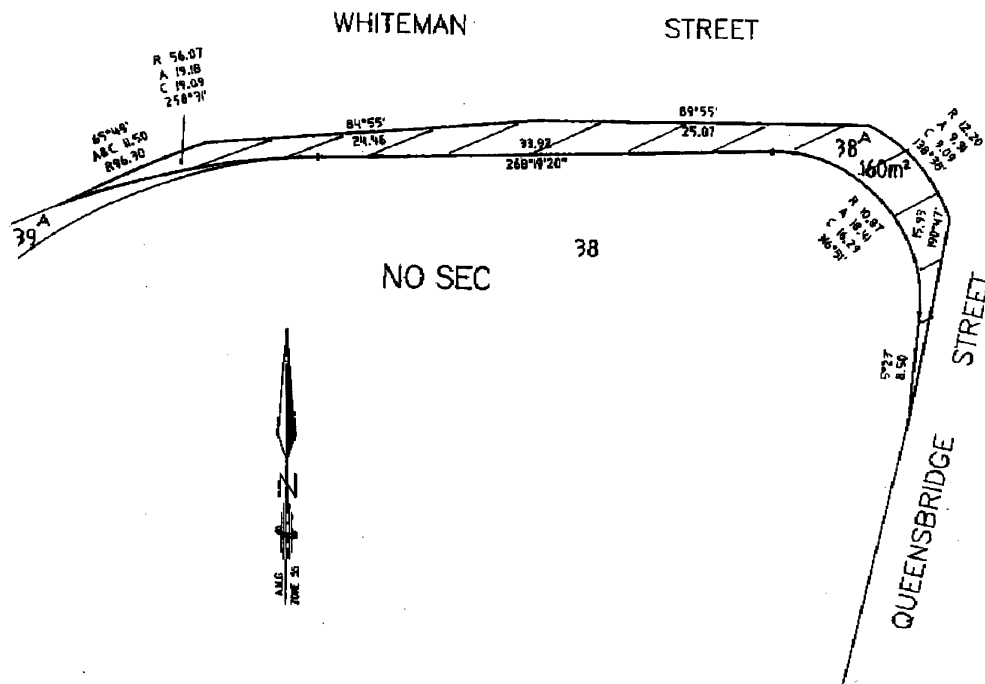

Dated 28 May 2002  
Responsible Minister:  
MARY DELAHUNTY  
Minister for Planning

HELEN DOYE  
Clerk of the Executive Council

**Land Act 1958**

SALE OF CROWN LAND BY PRIVATE TREATY

Order in Council

The Governor in Council, pursuant to section 99A(1)(a) 99A(2) of the **Land Act 1958**, approves the sale of Crown Allotment 2017, City of South Melbourne, Parish of Melbourne South, located at Power Street, South Melbourne.

Dated 28 May 2002  
Responsible Minister:  
JOHN LENDERS MP  
Minister for Finance

HELEN DOYE  
Clerk of the Executive Council

**Crown Land (Reserves) Act 1978**

**NOTICE OF INTENTION TO REVOKE  
TEMPORARY RESERVATION**

The Governor in Council under section 10 of the **Crown Land (Reserves) Act 1978** gives notice of intention to revoke the following temporary reservation:

**GHIN GHIN** — The temporary reservation by Order in Council of 26 February, 1958 of an area of 6.151 hectares of land in Section 7, Township of Ghin Ghin, Parish of Ghin Ghin as a site for Public purposes, revoked as to part by Order in Council of 1 March, 1988, so far only as the portion containing 1900 square metres, more or less, being Crown Allotment 2002, Township of Ghin Ghin as indicated by hatching on plan hereunder. (GP889) — (Rs 7693).

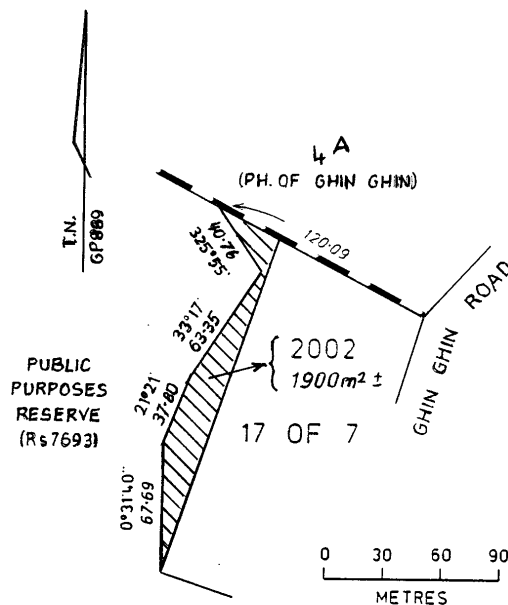

This Order is effective from the date on which it is published in the Government Gazette.

Dated 28 May 2002

Responsible Minister  
SHERRYL GARBUTT  
Minister for Environment  
and Conservation

HELEN DOYE  
Clerk of the Executive Council

**Crown Land (Reserves) Act 1978**

**REVOCATION OF TEMPORARY  
RESERVATIONS**

The Governor in Council under section 10 of the **Crown Land (Reserves) Act 1978** revokes the following temporary reservations:

**LAKE BOGA** — The temporary reservation by Order in Council of 20 July, 1925 of an area of 1.153 hectares of land in the Township of Lake Boga, Parish of Kunat Kunat as a site for a Tree Plantation, revoked as to part by Orders in Council of 29 March 1983 and 2 July 1996 so far as the balance remaining containing 4556 square metres, more or less. — (Rs 6249).

**MORDIALLOC** — The temporary reservation by Order in Council of 18 January 1949 of an area of 726 square metres of land in Section 11, City of Mordialloc, Parish of Mordialloc as a site for Police and Court House purposes. — (Rs 6312).

This Order is effective from the date on which it is published in the Government Gazette.

Dated 28 May 2002

Responsible Minister  
SHERRYL GARBUTT  
Minister for Environment  
and Conservation

HELEN DOYE  
Clerk of the Executive Council

**Crown Land (Reserves) Act 1978**

**TEMPORARY RESERVATION OF CROWN  
LANDS**

The Governor in Council under section 4(1) of the **Crown Land (Reserves) Act 1978** temporarily reserves the following Crown lands which in his opinion are required for the purposes mentioned :-

**MUNICIPAL DISTRICT OF THE  
COLAC OTWAY SHIRE COUNCIL**

**APOLLO BAY** — Public purposes, 10.34 hectares being Crown Allotments 12A and 13A, Section 2, Township of Apollo Bay, Parish of Krambruk as shown on Original Plan No. 116164 lodged in the Central Plan Office. — (Rs 4917).

MUNICIPAL DISTRICT OF THE  
GANNAWARRA SHIRE COUNCIL

BAEL BAEL and DARTAGOOK - Management of wildlife and preservation of wildlife habitat, 37.4 hectares, more or less, being Crown Allotments 12F and 28A, Section D, Parish of Bael Bael and Crown Allotment 1A, Section D, Parish of Dartagook as indicated by hatching on plan hereunder. (GP978) — (06/L6-10671).

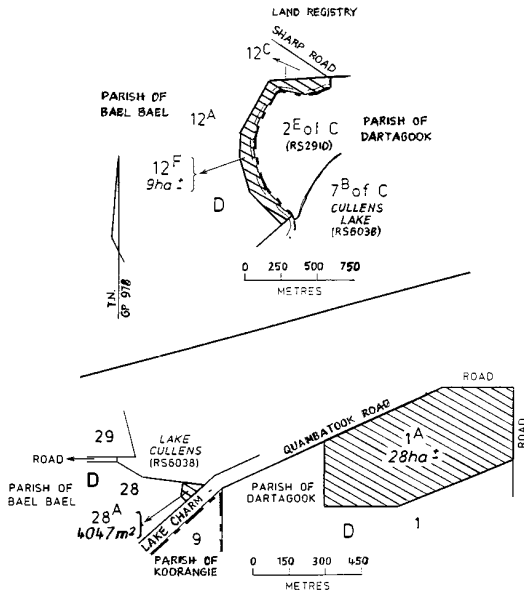

Total area of hatched portions is 37.4ha :

MUNICIPAL DISTRICT OF THE  
NORTHERN GRAMPIANS SHIRE COUNCIL

BANYENA — Management of wildlife and preservation of wildlife habitat, 10.47 hectares, being Crown Allotments 3B and 3C, Section B, Parish of Banyena as indicated by hatching on plan hereunder. (GP969) — (06/L6-4513).

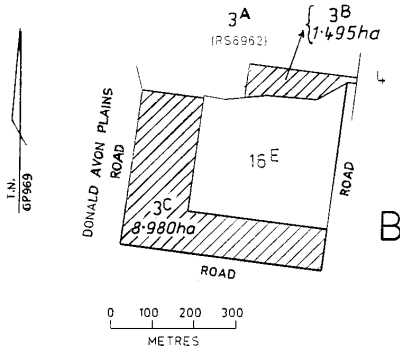

Total area of hatched portions is 10.47ha

MUNICIPAL DISTRICT OF THE  
WEST WIMMERA SHIRE COUNCIL

CHARAM — Management of wildlife and preservation of wildlife habitat, 27.74 hectares, being Crown Allotment 2001, Parish of Charam as indicated by hatching on plan hereunder. (GP975) — (Rs 35107).

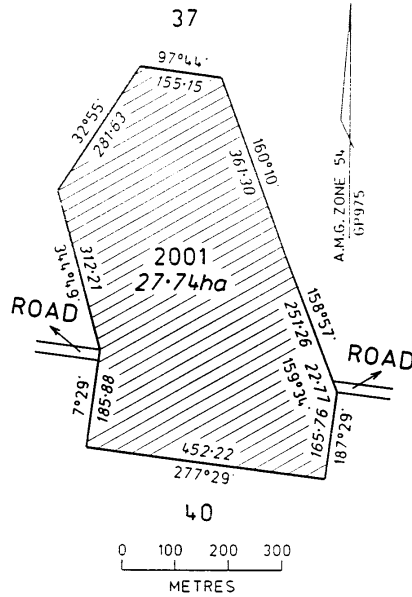

MUNICIPAL DISTRICT OF THE  
MILDURA RURAL CITY COUNCIL

COWANGIE and TUTYE — Conservation of an area of natural interest, 30.91 hectares, being Crown Allotment 60, Township of Cowangie and Crown Allotment 8, Parish of Tutye as indicated by hatching on plan hereunder. (GP988) — (01/2011967).

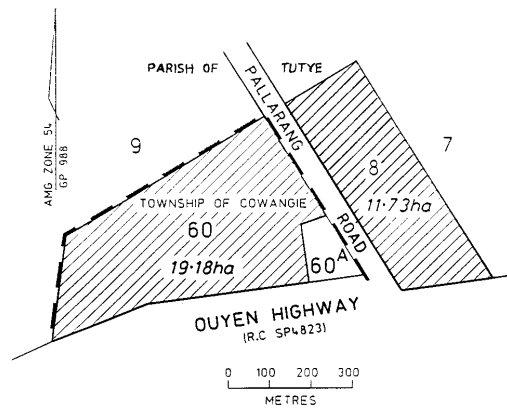

Total area of hatched portions is 30.91ha

MUNICIPAL DISTRICT OF THE  
MOORABOOL SHIRE COUNCIL

KORKUPERRIMUL — Conservation of an area of natural and scientific interest, 2,011 hectares being Crown Allotment 16, Section 16, Parish of Korkuperrimul as shown on Original Plan No. 120226 lodged in the Central Plan Office. — (07/4542).

MUNICIPAL DISTRICT OF THE  
BULOKE SHIRE COUNCIL

PIER-MILLAN — Conservation of an area of natural interest, total area 53.29 hectares being Crown Allotments 14C, 14D and 14E, Parish of Pier-Millan as shown on Original Plan No. 121379 lodged in the Central Plan Office. — (Rs 11463).

MUNICIPAL DISTRICT OF THE  
MILDURA RURAL CITY COUNCIL

PIRRO — Conservation of an area of natural interest, total area 585.33 hectares being Crown Allotments 2003, 2005, 2007 and 2010, Parish of Pirro as shown on Original Plan No. 121629 (Sheets 1 & 2) lodged in the Central Plan Office. — (Rs 13221)

MUNICIPAL DISTRICT OF THE  
BASS COAST SHIRE COUNCIL

VENTNOR — Public Recreation, 2,023 hectares, being Crown Allotment 1, Section 13, Township of Ventnor, Parish of Phillip Island as indicated by hatching on plan hereunder. (GP985) — (Rs 31031).

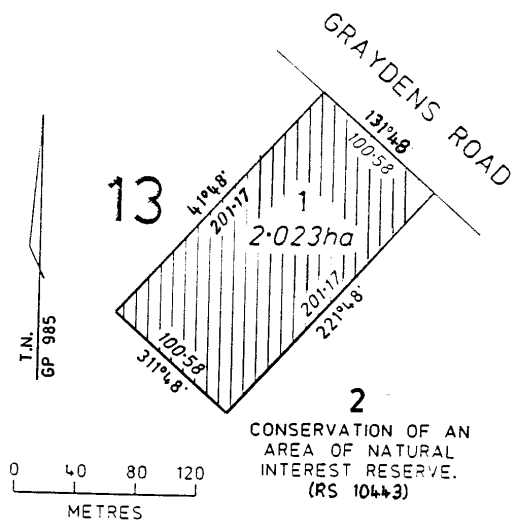

MUNICIPAL DISTRICT OF THE  
BULOKE SHIRE COUNCIL

WOORONOOK — Management of wildlife and preservation of wildlife habitat, 209.3 hectares, more or less, being Crown Allotments 42A and 67D, Parish of Wooronook as indicated by hatching on plan hereunder. (GP973) — (06/L62166).

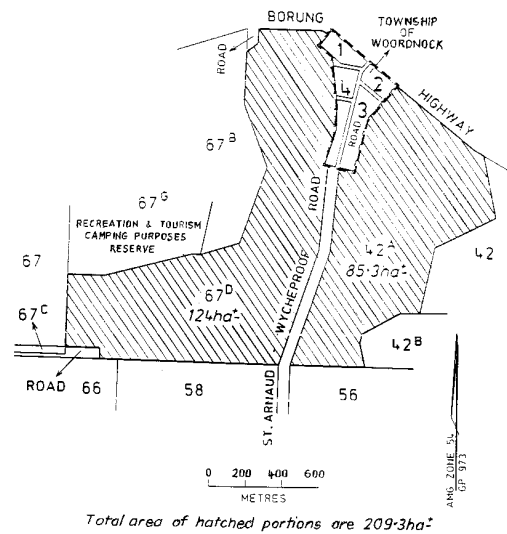

This Order is effective from the date on which it is published in the Government Gazette.

Dated 28 May 2002

Responsible Minister  
SHERRYL GARBUTT  
Minister for Environment  
and Conservation

HELEN DOYE  
Clerk of the Executive Council

**Crown Land (Reserves) Act 1978**  
DISSOLUTION OF INCORPORATED  
COMMITTEE OF MANAGEMENT  
BEAUFORT SWIMMING POOL RESERVE

The Governor in Council under Section 14A(7) of the **Crown Land (Reserves) Act 1978** dissolves the "Beaufort Swimming Pool Committee of Management Incorporated" constituted by Order in Council of 17 May, 1994

(vide Government Gazette of 19 May, 1994 — pages 1235 and 1236). — Rs 6662.

This Order is effective from the date on which it is published in the Government Gazette.

Dated 28 May 2002

Responsible Minister  
SHERRYL GARBUTT  
Minister for Environment  
and Conservation

HELEN DOYE  
Clerk of the Executive Council

**Land Act 1958**

**CLOSURE OF UNUSED ROADS**

The Governor in Council under section 349 of the **Land Act 1958** and with the concurrence in writing of the municipalities in which the roads are situated and the owners of land adjoining those roads closes the following unused roads:

**MUNICIPAL DISTRICT OF THE  
COLAC OTWAY SHIRE COUNCIL**

AIRE — The roads in the Parish of Aire shown as Crown Allotments 2001 and 2002 on Original Plan No. 121660 lodged in the Central Plan Office. — (05/11570).

**MUNICIPAL DISTRICT OF THE  
SHIRE OF YARRA RANGES**

MONBULK — The road in the Parish of Monbulk shown as Crown Allotments 2001, 2002 and 2003 on Original Plan No. 121737 lodged in the Central Plan Office. — (12/L12-1239).

**MUNICIPAL DISTRICT OF THE  
HINDMARSH SHIRE COUNCIL**

TARRANGINNIE — The road in the Parish of Tarranginnie being Crown Allotment 2001 as indicated by hatching on plan hereunder. (GP1000) — (2011907).

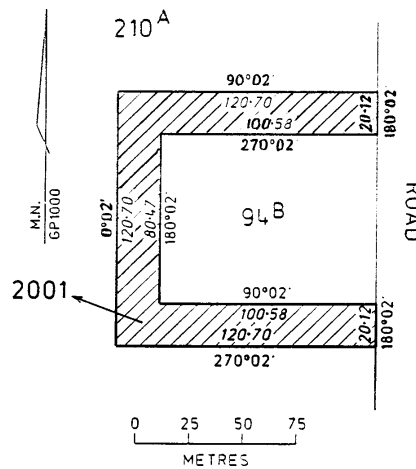

**MUNICIPAL DISTRICT OF  
TOWONG SHIRE COUNCIL**

TOWONG — The road in the Township of Towong, Parish of Towong being Crown Allotment 2005 as indicated by hatching on plan hereunder. (GP966) — (11/P204225).

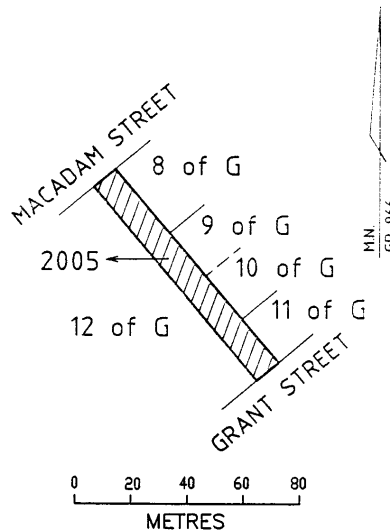

This Order is effective from the date on which it is published in the Government Gazette.

Dated 28 May 2002

Responsible Minister  
SHERRYL GARBUTT  
Minister for Environment  
and Conservation

HELEN DOYE  
Clerk of the Executive Council

**Crown Land (Reserves) Act 1978**INCORPORATION OF COMMITTEES OF MANAGEMENT AND  
APPOINTMENT OF CHAIRPERSONS

The Governor in Council under section 14A(1) of the **Crown Land (Reserves) Act 1978**, being satisfied that it is in the public interest to declare to be corporations the Committees of Management appointed under section 14(2) of the Act of the lands described in Column 1 of the schedule hereunder:—

- (a) declares that the Committees of Management shall be corporations;
- (b) assigns the names shown in Column 2 to the corporations; and
- under section 14B(3) of the Act, appoints the persons listed in Column 3 to be Chairpersons of the corporations.

**SCHEDULE**

<b>Column 1 Reserve details</b>	<b>Column 2 Corporate name</b>	<b>Column 3 Chairperson</b>
<b>Koondrook Recreation Reserve</b> — The lands in the Township of Koondrook and Parish of Murrabit temporarily reserved for Cricket and other purposes of Public Recreation by Orders in Council of 16 August, 1881 (vide Government Gazette of 19 August, 1881 – page 2423) and 25 October, 1938 (vide Government Gazette of 2 November, 1938 – page 3624) [Rs 881].	Koondrook Recreation Reserve Committee Incorporated	Gordon John HILL
<b>Murrabit Recreation Reserves</b> — Crown Allotments 3, 4, 6 and 9, Section 4A, Township of Murrabit temporarily reserved for Public Recreation by Orders in Council of 6 August, 1985 (vide Government Gazette of 14 August, 1985 – page 3151) and 21 June, 1994 (vide Government Gazette of 23 June, 1994 – page 1751) [Rs 12905].	Murrabit Market Playground Reserve Committee Incorporated	Kenneth James BENNETT
<b>Emu Recreation and Hall Reserves</b> — The remaining lands in the Township of Emu temporarily reserved for Public Recreation by Order in Council of 16 July, 1901 (vide Government Gazette of 26 July, 1901 – page 2889) and for Public Hall by Order in Council of 7 March, 1923 (vide Government Gazette of 14 March, 1923 – page 859) [Rs 2454 & Rs 2703].	Emu Memorial Hall Committee Incorporated	Roland Guy MARTIN
<b>Manangatang Recreation Reserve</b> — The land in the Parish of Manangatang temporarily reserved for Public Recreation by Order in Council of 28 February, 1967 (vide Government Gazette of 8 March, 1967 – page) 801 [Rs 2469].	Manangatang Recreation Reserve Committee of Management Incorporated	Greg PLANT



Column 1 Reserve details	Column 2 Corporate name	Column 3 Chairperson
<p><b>North Harrow Recreation Reserves</b> — The lands in the Parish of Harrow temporarily reserved for Public Recreation by Orders in Council of 15 June, 1948 (vide Government Gazette of 23 June, 1948 – page 4148) and 24 February, 1970 (vide Government Gazette of 4 March, 1970 – page 540) [Rs 6185].</p>	<p>Harrow and District Recreation Reserve Committee Incorporated</p>	<p>Thomas W. HOULIHAN</p>
<p><b>Marungi Public Park Reserve</b> — The land in the Township of Marungi temporarily reserved for a Public Park by Order in Council of 20 September, 1920 (vide Government Gazette of 29 September, 1920 – page 3048) [Rs 2205].</p>	<p>Marungi Memorial Park Reserve Incorporated</p>	<p>Ralph WILLGOOSE</p>
<p><b>Lurg Hall and Public purposes Reserves</b> — The lands in the Parish of Lurg temporarily reserved for a Public Hall by Order in Council of 23 January, 1979; for Public purposes by Order in Council of 18 July, 1995 and deemed to be permanently reserved for the recreation, convenience or amusement of the public as published in the Gazette of 31 July, 1968, page – 2768 [Rs 9153 &amp; Rs 9393].</p>	<p>Lurg Hall and Reserves Committee Incorporated</p>	<p>Victoria PHELAN</p>

This Order is effective from the date on which it is published in the Government Gazette.

Dated 28 May 2002

Responsible Minister  
SHERRYL GARBUTT  
Minister for Environment  
and Conservation

HELEN DOYE  
Clerk of the Executive Council

#### **Crown Land (Reserves) Act 1978**

##### **DISSOLUTION OF INCORPORATED COMMITTEE OF MANAGEMENT CARAMUT RECREATION RESERVE**

The Governor in Council under Section 14A(7) of the **Crown Land (Reserves) Act 1978** dissolves the “Caramut Recreation Reserve Incorporated” constituted by Order in Council of 7 April, 1999 (vide Government Gazette of 8 April, 1999 — pages 822 and 823). — Rs 7005.

This Order is effective from the date on which it is published in the Government Gazette.

Dated 28 May 2002

Responsible Minister  
SHERRYL GARBUTT  
Minister for Environment  
and Conservation

HELEN DOYE  
Clerk of the Executive Council



**SUBORDINATE LEGISLATION ACT 1994  
NOTICE THAT STATUTORY RULES ARE  
OBTAINABLE**

Notice is hereby given under Section 17 (3) of the **Subordinate Legislation Act 1994** that the following Statutory Rules were first obtainable from Information Victoria, 356 Collins Street, Melbourne on the date specified:

33. *Statutory Rule:* Subordinate Legislation (Surveyors (Registration) Regulations 1992 – Extension of Operation) Regulations 2002
- Authorising Act:* Subordinate Legislation Act 1994
- Date first obtainable:* 28 May 2002
- Code A*
34. *Statutory Rule:* Subordinate Legislation (Surveyors (Fees) Regulations 1992 – Extension of Operation) Regulations 2002
- Authorising Act:* Subordinate Legislation Act 1994
- Date first obtainable:* 28 May 2002
- Code A*
35. *Statutory Rule:* Subordinate Legislation (Surveyors (Surveyors Board) Regulations 1992 – Extension of Operation) Regulations 2002
- Authorising Act:* Subordinate Legislation Act 1994
- Date first obtainable:* 28 May 2002
- Code A*

As from 1 April 2002, the pricing structure for the Victoria Government Gazette and Victorian Government Legislation will be as follows.

Retail price will vary according to the number of pages in each special or periodical gazette. The table below sets out the prices that apply.

<i>Price Code</i>	<i>No. of Pages (Including cover and blank pages)</i>	<i>Price*</i>
A	1–16	\$3.65
B	17–32	\$5.40
C	33–48	\$7.40
D	49–96	\$11.50
E	97–144	\$14.85
F	145–192	\$17.55
G	193–240	\$20.25
H	241–288	\$21.55
I	289–352	\$24.25
J	353–416	\$28.35
K	417–480	\$32.35
L	481–544	\$37.75
M	545–608	\$43.15
N	609–672	\$48.55
O	673–736	\$53.90
P	737–800	\$59.30

*\*All Prices Include GST*

**ADVERTISERS PLEASE NOTE**

As from 30 May 2002

The last Special Gazette was No. 89 dated 28 May 2002

The last Periodical Gazette was No. 1 dated 29 May 2001

**CONTENTS**

	Page
Estates of Deceased Persons	1068
Government and Outer Budget Sector	
Agencies Notices	1119
Orders in Council	1147
Acts — Casino Control; Land; Crown Land (Reserves)	
Private Advertisements	1068
Proclamations	1118

The Victoria Government Gazette is published by The Craftsman Press Pty. Ltd. with the authority of the Government Printer for the State of Victoria  
© State of Victoria 2002

ISSN 0819-5471

This publication is copyright. No parts may be reproduced by any process except in accordance with the provisions of the Copyright Act.

Products and services advertised in this publication are not endorsed by The Craftsman Press Pty. Ltd. or the State of Victoria and neither of them accepts any responsibility for the content or the quality of reproduction. The Craftsman Press Pty. Ltd. reserves the right to reject any advertising material it considers unsuitable for government publication.

Address all enquiries to the Government Printer for the State of Victoria  
Government Information and Communications Branch  
Department of Premier and Cabinet  
Level 3, 356 Collins Street  
Melbourne 3000  
Victoria Australia

**RETAIL SALES**

Information Victoria Bookshop  
356 Collins Street Melbourne 3000.  
Telephone enquiries 1300 366 356

City Graphics  
Level 1, 520 Bourke Street  
Melbourne 3000  
Telephone enquiries (03) 9600 0977

**Recommended Retail Price \$1.85 (includes GST)**

*Government and Outer Budget Sector Agencies please note:*  
**STYLE REQUIREMENTS.**

To ensure that material received can be reproduced, and that errors are minimised, the following guidelines are to be observed when submitting material by fax.

**Fax resolution:**

Material sent by fax should be transmitted using Fine Resolution (200 dots per inch by 200 dpi).

**Font size:**

Use 12 point (10 pitch) or larger.

**Font Style:**

Clear plain font styles, such as Helvetica, should be used.

**Graphics:**

Line drawings should be transmitted as large as possible to ensure clarity. Drawings up to A4 size sent by fax using Fine Resolution provide a good quality for reproduction.

**Avoid:**

Italics, underlining and full justification.

Ensure document is square when sending as documents that are sent skewed are difficult to read and process.

ISSN 0819-5471

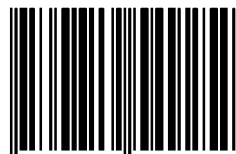

9 770819 549250