



Victoria Government Gazette

No. G 19 Thursday 9 May 2002

GENERAL

GENERAL AND PERIODICAL GAZETTE

Copy to: Gazette Officer
The Craftsman Press Pty. Ltd.
125 Highbury Road,
Burwood Vic 3125
Telephone: (03) 9926 1233
Facsimile: (03) 9926 1292
DX: 32510 Burwood
Email: gazette@craftpress.com.au

Advertising Rates and Payment

All prices include GST

Private Notices

Payment must be received in advance with advertisement details.

33 cents per word – Full page \$198.00.

Additional costs must be included in prepayment if a copy of the gazette is required. Copy Prices – Page \$1.65 – Gazette \$3.52 – Certified copy of Gazette \$3.85 (all prices include postage). *Cheques should be made payable to The Craftsman Press Pty. Ltd.*

Government and Outer Budget Sector Agencies Notices

Not required to prepay.

Advertisements may be faxed or sent via email with a cover sheet, marked to the attention of the Gazette Officer. Floppy Disks (Mac & PC) can also be accepted.

Costs can be calculated on the following basis:

Per Line	Typeset
Single column	\$1.71
Double column	\$3.41
Full Page	\$71.28

The Craftsman Press is pleased to offer a series of discounts from the typesetting costs.

1. Copy supplied on disk.
2. Copy supplied via email.
3. Artwork for forms and other material which require exact reproduction.

1. Copy supplied on disk.

Where a disk is supplied and there is minimum alteration required, **30% off.**

Where a disk is supplied requiring extraneous matter stripped out and styles applied, **20% off.**

2. Copy supplied via email.

Where a notice is sent via email and there is minimum alteration required, **25% off.**

Where email is supplied requiring extraneous matter stripped out and styles applied, **15% off.**

3. Artwork for forms and other material which requires exact reproduction.

Scanning and sizing of artwork for forms, to be reproduced in page format, **35% off.**

Copy Deadline for General Gazette

9.30 a.m. Monday – (Private Notices)

9.30 a.m. Tuesday – (Government and Outer Budget Sector Agencies Notices)

Advertisers should note:

- Late copy received at The Craftsman Press Pty. Ltd. after deadlines will be placed in the following issue of VGG, irrespective of any date/s mentioned in the copy (unless otherwise advised).
- Late withdrawal of advertisements (after client approval, before printing) will incur 50 per cent of the full advertising rate to cover typesetting, layout and proofreading costs.
- Proofs will be supplied only when requested or at the direction of the Gazette Officer.
- No additions or amendments to material for publications will be accepted by telephone.
- Orders in Council may be lodged prior to receiving assent with the Governor's or Clerk's signature. They will only be published once approved and signed.
- Accounts over 90 days will be issued with a letter of demand.
- Government and Outer Budget Sector Agencies please note: *See style requirements on back page.*

SPECIAL GAZETTES

Copy to: Gazette Officer
The Craftsman Press Pty. Ltd.
125 Highbury Road
Burwood Vic 3125
Telephone: (03) 9926 1233
Facsimile: (03) 9926 1292
Email: gazette@craftpress.com.au

Advertising Rates and Payment

Private Notices

Full Page \$396.00

Payment must be received in advance with notice details.

Government and Outer Budget Sector Agencies Notices

	Typeset
Full Page	\$96.25

Note:

The after hours number for Special Gazettes is:
Telephone: 0419 327 321

SUBSCRIPTIONS AND RETAIL SALES

Copies of the *Victoria Government Gazette* can be purchased from The Craftsman Press Pty. Ltd. by subscription.

The *Victoria Government Gazette*

General and Special – \$187.00 each year

General, Special and Periodical – \$249.70 each year

Periodical – \$124.30 each year

Subscriptions are payable in advance and accepted for a period of one year. All subscriptions are on a firm basis and refunds will not be given.

All payments should be made payable to The Craftsman Press Pty. Ltd.

Subscription enquiries:

The Craftsman Press Pty. Ltd.
125 Highbury Road, Burwood Vic 3125
Telephone: (03) 9926 1233

INDEX TO PRIVATE ADVERTISERS

A

A.B. Natoli Pty.827
 Andrew G. J. Rowan827

B

Borchard & Moore827

C

Cooks827

D

De Marco & Co.827

E

Eales & Mackenzie828
 Elinghaus Weill828

G

Gray Friend & Long828

J

John Stewart828

M

McNab, McNab & Starke828
 Marshalls & Dent828

P

Pearce Webster Dugdales829
 Perpetual Trustees Victoria Limited829
 Perpetual Trustees Consolidated Limited . .829

R

Rennick & Gaynor830
 Roberts Partners830

T

Taylor & Pitts830
 Tolhurst Druce & Emmerson830

V

Verhoeven & Curtain830

W

Wills & Probate Victoria831

PRIVATE ADVERTISEMENTS

MARGARET MARY McCARTHY, late of 8A Uonga Road, Bentleigh, Victoria, widow, deceased. Creditors, next-of-kin and others having claims in respect of the estate of the abovenamed deceased, who died on 30 December 2001, are required by Catherine Lynette Michell and George Henry Cuthbert Wall, the executors of the deceased's will, to send particulars of their claim to the said executors care of the undermentioned solicitors by a date not later than two months from the date of publication hereof, after which date they will convey or distribute the assets having regard only to the claims of which they then have notice.

A.B. NATOLI PTY., solicitors,
24 Cotham Road, Kew 3101.

MARJORY ETTIE DONCASTER COLLARD, late of Villagio Sant' Antonio, 35 Burkitt Street, Page, Australian Capital Territory, widow, deceased. Creditors, next-of-kin and others having claims in respect of the estate of the deceased, who died on 20 January 2002, are required by Equity Trustees Limited, ACN 004 031 298, the proving executor of the will of the deceased, to send particulars of their claims to the executor in the care of the undermentioned solicitor by 10 July 2002 after which date the executor may convey or distribute the assets having regard only to the claims of which it then has notice.

ANDREW G. J. ROWAN, solicitor,
Level 4, 472 Bourke Street, Melbourne 3000.

EDITH GRACE KEMP, late of Perpetua in the Pines, 300 Springvale Road, Donvale, Victoria, gentlewoman, deceased. Creditors, next-of-kin and others having claims in respect of the estate of the deceased, who died on 21 February 2002, are required by Equity Trustees Limited, ACN 004 031 298, the proving executor of the will of the deceased, to send particulars of their claims to the executor in the care of the undermentioned solicitor by 10 July 2002 after which date the executor may convey or distribute the assets having regard only to the claims of which it then has notice.

ANDREW G. J. ROWAN, solicitor,
Level 4, 472 Bourke Street, Melbourne 3000.

Re: EUGENE MASLENNIKOFF late of St. John of Kronstadt Russian Welfare Society, 13 Conway Street, Dandenong, Victoria, but formerly of 9 Alexander Avenue, Dandenong, Victoria, retired, deceased. Creditors, next-of-kin and others having claims in respect of the estate of the deceased, who died on 21 September 2000, are required by the trustees, Ludmela Hoffman of 25 Sunrise Street, Mount Cotton, Queensland, sales assistant, daughter and Boris Maslennikoff of Lot 138 Mahogany Drive, Traralgon, Victoria, retired carpenter, son, to send particulars to the trustees by 23 July 2002 after which date the trustees may convey or distribute the assets, having regard only to the claims of which the trustees have notice.

BORCHARD & MOORE, solicitor,
44 Douglas Street, Noble Park 3174.

Re: Estate LYNETTE MAY GODING, deceased. Creditors, next-of-kin or others having claims in respect of the estate of LYNETTE MAY GODING of 5/28 Stanhope Street, Footscray West, in the State of Victoria, home duties, who died on 2 October 2002, are to send particulars of their claims to the personal representatives care of the undermentioned solicitors by 18 July 2002 after which date the personal representatives will distribute the assets having regard only to the claims of which they then had notice.

COOKS, solicitors,
Level 10,
535 Bourke Street, Melbourne, Vic. 3000.

Re: ANNA RYCAK, late of 7 King Street, Glenroy, Victoria, home duties, deceased. Creditors, next-of-kin and others having claims in respect of the estate of the deceased, who died on 5 February 2002, are required by the trustee, Stanislaw Rycak of 30 McMillan Street, Traralgon, Victoria, boilermaker, son, to send particulars to the trustee within sixty days from the publication hereof after which date the trustee may convey or distribute the assets, having regard only to the claims of which the trustee has notice.

DE MARCO & CO., solicitors,
209 Glenroy Road, Glenroy 3046.

Re: HERBERT KNEALE (also known as Peter Kneale) late of 53 St Andrews Drive, Chirnside Park 3116, but formerly of 402 St George's Road, Fitzroy, Board of Works employee, deceased. Creditors, next-of-kin and others having claims in respect of the estate of the deceased, who died on 4 February 2002, are required by the trustee, Judith Ann Law of 53 St Andrews Drive, Chirnside Park, Victoria, daughter, to send particulars to the trustee by 10 July 2002 after which date the trustee may convey or distribute the assets, having regard only to the claims of which the trustee has notice.

EALES & MACKENZIE, solicitors,
142 Main Street, Lilydale 3140.

GRAHAM LEONARD CANNAN, late of Unit 2, 12 Dering Street, Diamond Creek, furniture removalist, deceased. Creditors, next-of-kin and others having claims in respect of the estate of the deceased, who died on 30 January 2002, are required by the personal representative, Raymond Leonard Cannan of 3 Nullumbik Square, Diamond Creek, to send particulars to him care of the undermentioned solicitors by 17 July 2002 after which date the personal representative may convey or distribute the assets having regard only to the claims of which he then has notice.

ELINGHAUS WEILL, solicitors,
79–81 Franklin Street, Melbourne 3000.

JOHN MARTIN EDNIE, late of Fairview Homes for the Aged, Sargeant Street, Warragul, retired, deceased. Creditors, next-of-kin and others having claims in respect of the estate of the deceased, who died on 19 March 2002, are required by the trustees, Lance Stephen Hill and Frederick George Evison, to send particulars of their claims to them care of the undersigned solicitors by 10 July 2002 after which date the trustees may convey or distribute the assets having regard only to the claims of which they then have notice.

GRAY FRIEND & LONG, solicitors,
70 Queen Street, Warragul 3820.

Creditors, next-of-kin and others having claims in respect of the will of PHOEBE ELIZABETH LEACH, late of 4/16 South

Circular Road, Tullamarine, Victoria, widow, deceased, who died on 30 March 2002, are requested to send particulars of their claims to the executors, Richard Louis George Leach and Mavis Mona, care of the undermentioned legal practitioner by 10 July 2002 after which date they will distribute the assets having regard only to the claims of which they then have notice.

JOHN STEWART, legal practitioner,
290 Racecourse Road, Newmarket.

MAIE LORRAINE EDMUNDS, late of Colton Close, 1–19 York Street, Glenroy, in the State of Victoria, widow, deceased. Creditors, next-of-kin and others having claims in respect of the estate of the above deceased, who died at Parkville on 11 February 2002, are required by the executor and trustee of the said deceased, William John Redfern care of McNab, McNab & Starke of 21 Keilor Road, Essendon, to send particulars to him by 10 July 2002 after which date the trustee may convey or distribute the assets having regard only to the claims of which he then has notice.

Dated 2 May 2002

McNAB, McNAB & STARKE, solicitors,
21 Keilor Road, Essendon 3040.
Telephone 9379 2819.

Re: MONA LAVENIA BOLES, late of 171 Church Street, Brighton, Victoria, but formerly of Unit 1, 36 Burrows Street, Brighton, Victoria, home duties, deceased. Creditors, next-of-kin and others having claims in respect of the estate of the deceased, who died on 7 February 2002, are required by the trustees, Merilyn Joyce Bourke of Unit 1, 36 Burrows Street, Brighton, Victoria, writer, daughter and William Thomas Marshall of Unit 3, 18 Dickens Street, Glen Iris, Victoria, lawyer, to send particulars to the trustees by 11 July 2002 after which date the trustees may convey or distribute the assets, having regard only to the claims of which the trustees have notice.

MARSHALLS & DENT, solicitors,
Level 13,
459 Little Collins Street, Melbourne 3000.

Re: LLOYD JAMES LIDGETT, late of "Rosebank", Myrniong, Victoria, grazier, deceased. Creditors, next-of-kin and others

having claims in respect of the estate of the deceased, who died on 12 October 2001, are required by the trustee, James William Lidgett of Mt Blackwood Road, Myrniong, Victoria, farmer, to send particulars to the trustee by 8 July 2002 after which date the trustee may convey or distribute the assets having regard only to the claims of which the trustee has notice.

PEARCE WEBSTER DUGDALES, solicitors,
379 Collins Street, Melbourne.

MARJORIE ESTELLE EADON (in the will called Majorie Estelle Eadon), late of "Seven Oaks", Plenty Road, Yan Yean, Victoria. Creditors, next-of-kin and others having claims in respect of the estate of the deceased, who died on 17 July 2001, are required by Perpetual Trustees Victoria Limited, ACN 004 027 258 (in the will called The Perpetual Executors and Trustees Association of Australia Limited) of 360 Collins Street, Melbourne, Victoria, to send particulars of their claims to the said company by 10 July 2002 after which date it will convey or distribute the assets having regard only to the claims of which the company then has notice.

ESMEY ZOULIEM EISENHAEUER (also known as Esme Zoulene Eisenhauer), late of Chelsea Park Nursing Home, 53-57 Broadway, Chelsea, Victoria, formerly of 32 Reading Avenue, North Balwyn, Victoria. Creditors, next-of-kin and others having claims in respect of the estate of the deceased, who died on 20 October 2001, are required by Perpetual Trustees Consolidated Limited, ACN 004 029 841 (in the will called National Mutual Trustees Limited) of 360 Collins Street, Melbourne, Victoria, to send particulars of their claims to the said company by 10 July 2002 after which date it will convey or distribute the assets having regard only to the claims of which the company then has notice.

ARTHUR MAXWELL HART, late of Camberlea Nursing Home, 629 Riversdale Road, Forest Hill, Victoria, formerly of 17 Arthur Street, North Caulfield, Victoria. Creditors, next-of-kin and others having claims in respect of the estate of the deceased, who died on 10 January 2002, are required by Perpetual

Trustees Victoria Limited, ACN 004 027 258 (in the will called The Perpetual Executors and Trustees Association of Australia Limited) of 360 Collins Street, Melbourne, Victoria, to send particulars of their claims to the said company by 10 July 2002 after which date it will convey or distribute the assets having regard only to the claims of which the company then has notice.

MARY LOUISA McPHERSON, late of Carnsworth Nursing Home, 10 A'Beckett Street, Kew, Victoria, formerly of Flat 1/36 Mandeville Crescent, Toorak, Victoria. Creditors, next-of-kin and others having claims in respect of the estate of the deceased, who died on 6 November 2001, are required by Perpetual Trustees Consolidated Limited, ACN 004 029 841 (in the will called National Mutual Trustees Limited) of 360 Collins Street, Melbourne, Victoria, to send particulars of their claims to the said company by 10 July 2002 after which date it will convey or distribute the assets having regard only to the claims of which the company then has notice.

VERA MAY MOLLISON, late of 26 Irilbarra Road, Canterbury, Victoria. Creditors, next-of-kin and others having claims in respect of the estate of the deceased, who died on 29 December 2001, are required by Perpetual Trustees Victoria Limited, ACN 004 027 258 of 360 Collins Street, Melbourne, Victoria, to send particulars of their claims to the said company by 10 July 2002 after which date it will convey or distribute the assets having regard only to the claims of which the company then has notice.

JACQUELINE YOKE LIN WELLS (also known as Lin Yace Chan), late of 3 Ellison Street, Malvern East, Victoria. Creditors, next-of-kin and others having claims in respect of the estate of the deceased, who died on 19 December 2001, are required by Perpetual Trustees Victoria Limited, ACN 004 027 258 of 360 Collins Street, Melbourne, Victoria (the other executor, Anthony Cardale Wells having predeceased the deceased), to send particulars of their claims to the said company by 10 July 2002 after which date it will convey or distribute the assets having regard only to the claims of which the company then has notice.

ELIZABETH MARGARET MULQUEEN, late of Amaroo Private Nursing Home, 294 Maroondah Highway, Ringwood, Victoria, widow, deceased. Creditors, next-of-kin and others having claims in respect of the estate of the deceased, who died on 22 February 2002, are required by the executor, David Anthony Rush of 431 Riversdale Road, Hawthorn East, Victoria, to send particulars to him (care of the undersigned) by 8 July 2002 after which date the executor may convey or distribute the assets having regard only to the claims of which he then has notice.

RENNICK & GAYNOR, solicitor,
431 Riversdale Road, Hawthorn East.

Re: ARTHUR WILLIAM SIMS, late of Camberlea Nursing Home, Riversdale Road, Camberwell, but formerly of 1 Madden Grove, Kew, estate agent, deceased. Creditors next-of-kin or others having claims in respect of the estate of the deceased, who died on 26 March 2002, are required by the trustees, Barbara Grace Grant of 49 Ian Road, Mount Martha, Victoria, real estate agent and Vivienne Kay Tonkin of 63 View Hill Road, North Balwyn, Victoria, home duties, to send particulars to the trustees by 10 July 2002 after which date the trustees may convey or distribute the assets, having regard only to the claims of which the trustees then have notice.

ROBERTS PARTNERS, lawyers,
216 Main Street, Mornington.

WONG SHIN, late of Milburn Road, Keilor 3036. Creditors, next-of-kin and others having claims in respect of the estate of the deceased, who died on 9 August 1942, are required by the trustees for administration of his estate, Joyce Violet Wang of 7/339 George Street, Doncaster 3108 and Alen Keith Wong of 4 Barmah Drive, Wantirna 3152, to send particulars to them care of their solicitors, Taylor and Pitts, Suite 3, 1016 Doncaster Road, Doncaster 3109 by 10 July 2002 after which date the trustees may convey or distribute the assets having regard only to the claims of which they then have notice.

TAYLOR & PITTS solicitors,
Suite 3,
1016 Doncaster Road, Doncaster East 3109.

Re: JOHN EDWARD GRAHAM, deceased. Creditors, next-of-kin and others having claims against the estate of JOHN EDWARD GRAHAM, late of 1 Lake Road, Blackburn, Victoria, retired accountant, deceased, who died on 4 December 2001, are required to send particulars of their claims to David John Graham of 74 Tennyson Street, Kew, Victoria, supervisor, Robert Mackie Wilson of 6 Rylie Place, Vermont South, Victoria, accountant and Peter Francis Druce of 31 Wilson Street, North Carlton, Victoria, legal practitioner, the administrators of the said deceased on or before 17 July 2002 after which date they will distribute the assets having regard only to the claims of which they then have notice.

TOLHURST DRUCE & EMMERSON,
solicitors,
520 Bourke Street, Melbourne.

Creditors, next-of-kin and others having claims against the estate of STANLEY PATERSON THOMAS, late of 9 Charmaine Street, Dromana, retired, deceased, who died on 29 September 2001, are required to send particulars of their claims to William Randall Bradshaw care of the undersigned solicitors, the executors of the will of the said deceased on or before 12 July 2002 after which date he will distribute the assets having regard only to the claims of which he then has notice.

TOLHURST DRUCE & EMMERSON,
solicitors,
520 Bourke Street, Melbourne.

MARTIN ROVTAR, late of 8 Roberts Street, Moe, in the State of Victoria, pensioner, deceased. Creditors, next-of-kin and others having claims in respect of the estate of the deceased, who died on 19 September 2001, are required by the personal representative, Margaret May Wilson of 1/19 Abbott Street, Upper Burnie, Tasmania, to send particulars to her care of the undermentioned solicitors by 1 August 2002 after which date the personal representative may convey or distribute the assets, having regard only to the claims of which she then has notice.

VERHOEVEN & CURTAIN, solicitors,
Suite 4, 47 Haigh Street, Moe 3825.

Re: THOMAS VINCENT MILLEA, late of 10 Powderham Road, North Caulfield, Victoria. Creditors, next-of-kin and others having claims in respect of the estate of the deceased, who died on 30 December 2001, are required to send particulars of their claims to the administrators, C/-Wills & Probate Victoria – Lawyers, GPO Box 1946R, Melbourne 3001 by 4 July 2002 after which date the executor may convey or distribute the assets having regard only to the claims of which they may then have notice.

WILLS & PROBATE VICTORIA – lawyers,
Level 5, 360 Little Bourke Street, Melbourne.

In the Supreme Court of the State of Victoria
SALE BY THE SHERIFF

On Wednesday 5 June 2002 at 2.30 p.m. at the Sheriff's Office, 8-20 King Street, Oakleigh, (unless process be stayed or satisfied).

All the estate and interest (if any) of Adrian Scott Watkinson of 1405 Dandenong Road, Malvern East, proprietor of an estate in fee simple as to one of a total of four equal undivided shares registered as Tenants in Common with Malcolm Eric Watkinson as to the other three of a total of four equal undivided shares and being the land described on Certificate of Title Volume 7198, Folio 596 upon which is erected a dwelling known as 1405 Dandenong Road, Malvern East.

Terms – Cash/Eftpos
(Debit Cards only/No Credit Cards)
SW-01-009121-1
Dated 2 May 2002

S. BLOXIDGE
Sheriff's Office

In the Supreme Court of the State of Victoria
SALE BY THE SHERIFF

On Wednesday 5 June 2002 at 2.30 p.m. at the Sheriff's Office, 8-20 King Street, Oakleigh, (unless process be stayed or satisfied).

All the estate and interest (if any) of Paul Kennedy of 11 Orama Avenue, Carrum Downs, as shown on Certificate of Title as Paul Anthony Kennedy, proprietor of an estate in fee simple in the land described on Certificate of Title Volume 10166, Folio 824 upon which is erected a dwelling known as 11 Orama Avenue, Carrum Downs.

Registered Mortgage No. V830308Y and the Covenant No. V830307C affect the said estate and interest.

Terms – Cash/Eftpos
(Debit Card only, No Credit Cards)
SW-01-002135-0
Dated 2 May 2002

S. BLOXIDGE
Sheriff's Office

In the Supreme Court of the State of Victoria
SALE BY THE SHERIFF

On Wednesday 5 June 2002 at 2.30 p.m. at the Sheriff's Office, 8-20 King Street, Oakleigh, (unless process be stayed or satisfied).

All the estate and interest (if any) of Leo A. Humar of 37 Central Avenue, Croydon South as shown on Certificate of Title as Leopold Alfred Humar, joint proprietor with Vanda Nancy Humar of an estate in fee simple in the land described on Certificate of Title Volume 8440, Folio 463 upon which is erected a house known as 37 Central Avenue, Croydon South.

Registered Mortgage No. P361584P affects the said estate and interest.
Terms – Cash/Eftpos
(Debit Card only. No Credit Cards)
SW-02-000496-5
Dated 2 May 2002

S. BLOXIDGE
Sheriff's Office

Unclaimed Moneys Act 1962

Register of Unclaimed Moneys held by the —

<i>Name of Owner on Books and Last Known Address</i>	<i>Total Amount Due to Owner</i>	<i>Description Of Unclaimed Money</i>	<i>Date when Amount first became Payable</i>
ARNOLD, THOMAS & BECKER SOLICITORS			
	\$		
Laura Elizabeth McMahon-Harrison, C/o Mrs L. McMahon, 192 Arthur Street, Fairfield	500.00	Cheque	26/03/01
02140 CONTACT: TANYA STEINMANN, PHONE: (03) 9614 1433.			

Unclaimed Moneys Act 1962

Register of Unclaimed Moneys held by the —

<i>Name of Owner on Books and Last Known Address</i>	<i>Total Amount Due to Owner</i>	<i>Description Of Unclaimed Money</i>	<i>Date when Amount first became Payable</i>
CITY OF CASEY			
	\$		
Mr William Clark, 2 Jacaranda Street, Doveton	100.00	Cheque	28/02/01
02061 CONTACT : DOREEN COLLIER, PHONE : (03) 9705 5392.			

Unclaimed Moneys Act 1962

Register of Unclaimed Moneys held by the —

<i>Name of Owner on Books and Last Known Address</i>	<i>Total Amount Due to Owner</i>	<i>Description Of Unclaimed Money</i>	<i>Date when Amount first became Payable</i>
COLES MYER LTD. – MYER GRACE BROS			
	\$		
Anderson, Mr Mark – 8 Boyne St, East Coburg	117.80	Lay-by	19/12/00
Apted, Joanne – P O Box 4125, Richmond East	168.90	”	08/02/01

Ballingall, Mrs – 20 Country Club Drv, Safety Beach	160.05	''	04/03/00
Barnes, Holly – Pert St, Bairnsdale	173.80	''	24/12/00
Barnes,C – 18 Morven St, Mornington	217.80	''	04/02/01
Baker, Mrs – 11 Fenton Ave, Rosebud	100.00	''	09/03/00
Bonanno, Miss S – 13 Minnie St, Brunswick	150.00	''	12/03/00
Butler, Craig – 129 Hayrick Ave, Mooroolbark	440.02	''	22/12/00
Cameron, John – 1820 Fernbank–Glenaldal, Bairnsdale	218.05	''	15/11/00
Clements, C – 65 Wilblrdon, Mount Eliza	120.00	''	02/03/00
Colley, Daryl – 61 Isla Ave, Glenroy	125.35	''	13/02/01
Collins, C – 1/12–20 Foote St, Templestowe	128.00	''	23/05/00
Cooper, Gabi – 5 Beattie St, Montmerency	108.50	''	01/11/00
Cupid, J – 46 Aberon Drv, Carrum Downs	102.00	''	30/01/01
Delaney, Mrs M – 19 Ravenscourt Cres, Mount Eliza	100.00	''	11/12/00
Dilorio, Ms Maria – 9 Morth Rd, Avondale Heights	100.00	''	03/05/00
Evans, Mrs R – 5 Woodlyn Mews, Mt Eliza	206.85	''	14/08/00
Foti, Rosa – 13 Levendale Ave, Mooroolbark	109.60	''	02/12/00
Giles, Mrs Sue – 32 Fitzgerald St, Bairnsdale	108.00	''	30/04/00
Gilmore, Janet – 12 Sharp Grv, Merlynston	114.15	''	08/10/00
Ginovski, Onelia – 11 Apollp Crt, Hillside	101.52	''	25/10/00
Goonewardenes, Mr/Ms – 18 St.Marks Cls, Dingley	298.00	''	24/04/00
Hansen, Carolyn – 41 Beaver St, Essendon	288.42	''	05/03/00
Heseltine, Helen – 15 Lavender Park Rd, Eltham	111.70	''	08/04/00
Hocking, Miss – 1 Alicudi Ave, Frankston	837.90	''	19/09/00
Hood, Ivan – 241 Mcleod St, Bairnsdale	430.00	''	09/04/00
Janosa, D – 36 Yarrabin Drv, Mt Martha	298.00	''	29/05/00
Juste, Ms Veronique – 38 Peacock St, Burwood	100.00	''	29/06/00
Kemp, Ms K – 129 Nelson Rd, Lilydale	148.00	''	05/04/00
Kennedy, Wendy – 103 Brougham St, Ballarat	108.00	''	30/03/00
Kohlar, Michele – 1B Charles St, Seaford	394.00	''	03/04/00
Lancaster – 14 Wallace St , Bairnsdale,	286.20	''	29/12/00
Mackie, Ms E – 35 Wintersun Drv, St Albans	164.70	''	16/01/01
Manneken, Catherin – 7/25 Cavalier St, East Doncaster	200.00	''	12/12/00
Mannis, Amanda – 138 Peel St, Kew	350.00	''	03/03/00
McKnight, Mrs – P O Box 451, Buninyong	118.00	''	04/03/00
Melville, Eileen – 29 Boronia Rd, Boronia	201.00	''	22/12/00
Mercier, M – 60 Hall St, Newport	120.00	''	13/12/00
Misso, Phil – 16 Jacinta Drv, Cranbourne	104.00	''	12/09/00
O’Dea, Mrs – 8 Stonington Pld, Nth Ringwood	130.40	''	17/11/00
Osborne, Ms Cathy – 20 Mckittrick Rd, Moorabbin	600.80	''	05/02/01
Pace, F – 39 Pearson St, Bairnsdale	188.00	''	20/11/00
Patterson, Mrs G – 4 Somerset Drv, Mount Martha	298.00	''	06/03/00
Price, Ms Bronwyn – 2 Clifton St, East Bentleigh	148.00	''	12/10/00
Puckering, Mrs S – 24 Besant St, Moorabbin	147.80	''	31/12/00
Pudney, R – 19 Screen St, Frankston	137.80	''	18/10/00
Quiang, Mrs – 39 Lawson Ave, Frankston	357.85	''	30/04/00
Schofield, Deanne – 139 Connellys Creek Rd, Acheron	107.50	''	03/01/01
Sinclair, Juliane – 7 The Crescent, Footscray	198.00	''	06/03/00
Slakey, Sadie – 29 Church St, Beaumaris	174.05	''	29/03/00
Smith, G – 32 Moroney St, Bairnsdale	140.00	''	04/04/00
Soliman Sarah – 3 Lena Crt, Thomastown	121.80	''	17/01/01
Sorbello, Mr Kane – 11/ 24–28 Union St, Brunswick	232.00	''	19/01/01
Storer, B – 228 Princes Hwy, Drouin	133.00	''	03/03/00
Sullivan, Mrs M – 66 Dunns Rd, Mount Martha	210.30	''	16/10/00

Surgenor, Mrs – 13 Gregory Ave, Sth Frankston	200.00	”	15/12/00
Tondo, Mrs M – 79 Bowlen Rd, Doncaster East	132.80	”	17/11/00
Trainor, K – 4 Landell Crt, Ringwood East	220.00	”	01/08/00
Tran, Hong – 35 Kallara Grv, Footscray	807.80	”	19/04/00
Valastro, Mr/Ms B – 3 Derwent St, Mentone	230.80	”	30/04/00
Walkler, Janet – 12 Manna Gum Walk, Sth Morang	100.00	”	17/10/00
White, Ms Miriam – 12/9 Acacia St, Murrumbeena	112.80	”	25/12/00
Wiseman, Francene – 133 Fortescue Ave, Seaford	113.00	”	17/04/00
Woodward, Mrs – 20 Derinya Drv, Frankston	116.55	”	30/10/00
Woodward, Ms Lucy – 4 Tate Street, Pascoe Vale	142.80	”	08/10/00
A.E.R.O.S.	800.00	Cheque	13/07/00
Ansett Air Freight	108.22	”	09/02/01
Aust. Human Resources Inst	235.00	”	11/09/00
Booth, J.	230.54	”	30/11/00
Chan, Elizabeth	650.00	”	03/08/00
Deluxe Dry Cleaners	343.51	”	29/09/00
Dennison, Avery	101.59	”	24/01/01
Derrimere Pty Ltd	300.00	”	23/02/01
Dew, Ms Melissa	183.00	”	11/01/01
Ecolab Pty Ltd	167.97	”	23/10/00
Foda, S.	585.00	”	07/08/00
Konovolov, Mrs	149.00	”	02/06/00
Minolta	105.00	”	05/06/00
Molinaro, Drosia	633.00	”	14/08/00
Morris, Miss Vicky	106.50	”	26/06/00
New Age Sails, Blinds & Awnings	1,667.64	”	06/11/00
Pacific Access P/L	656.00	”	08/01/01
Roadshow, DJS	150.00	”	10/11/00
Schweppes Cottees	400.00	”	28/02/01
Spices Pty Ltd	448.26	”	11/01/01
Stephanek, Doby	149.90	”	06/10/00
Stirling Signs	320.00	”	08/12/00
Studio 3 Photograpy	100.00	”	13/11/00
Study Plus Pty Ltd	950.00	”	29/09/00
Tech Pacific	236.72	”	24/07/00
The Melbourne Pressing Co.	3,750.00	”	28/12/00
Voices	250.00	”	11/09/00
Waverley Council	200.00	”	26/02/01
Western Diagnostic Pathology	107.85	”	17/08/00
Westfield Shopping Cntr Mgmt	1,600.00	”	15/12/00
Whyte, Trish	120.00	”	19/06/00

COLES MYER LTD. – KMART

Barclay, Tina – 2 Marna St, Healesville	112.00	Lay-by	01/05/00
Boydle,Dianne J – 9 Earlston Crt, Cranbourne	214.89	”	24/02/01
Cunningham, K – 4/6 Lilac St, Horsham	107.50	”	22/03/00
Currie, A – 36 Bundina Ave, Keysborough	223.98	”	04/10/00
Davis,N – 47 Lamont Cres, Cranbourne	107.00	”	18/06/00
De Haan, Mrs Wilma – 7 Patterson Crt, Endeavour Hills	112.00	”	14/06/00
Deal, S – 15/11 Bates Rd, Warrnambool	201.35	”	31/08/00
Easton,Renee – 164 Patullos Rd, Yannathan	123.98	”	14/11/00
Haby, Frances B – 21 Philip Street, Horsham	114.89	”	12/02/01
Hussaini,A – 3 Carson Crt, Rowville	120.52	”	03/02/01

Ibrahim, O – 7 Scarborough Way, St Albans	135.00	”	10/03/00
Jenkins, Lisa – 1/37 Dandenong Rd Et, Frankston	125.80	”	24/04/00
Jovanovski, Vasko – 7 Harris St, St Albans	132.03	”	07/09/00
Kift, Dorinda – 217 Princes Way, Drouin	133.07	”	02/01/01
Marshall, Selina – 14 Ferry Close, Wyndhamvale	151.25	”	10/01/01
McDonald, S – 1/34 Mruinda St, East Ringwood	153.16	”	05/12/00
McDonald, A – 20 Caroola Crt, Rosebud	101.25	”	12/12/00
McKenna, K – 232 Sydenham Ave, Nth Bendigo	100.00	”	19/04/00
Meehan, L – 23 Stanley St, Orbost	106.53	”	12/12/00
Murrell, Susan – PO Box 250, Castlemaine	131.70	”	09/01/01
Pavlidis, H – 48 Sydney Rd, Brunswick	182.25	”	04/04/00
Peters, C – 26 Emily Drv, Narre Warren	217.93	”	06/12/00
Rc, Rogers Lyn – Unit 2/37 Doncaster East Rd, Mitcham	116.80	”	26/06/00
Richards, Lisa – 116 Millpark Dr, Millpark	219.05	”	17/04/00
Roberts, L – 17 The Parade, Northcote	269.53	”	08/11/00
Rowse, M – 405 Peel Street Nth, Ballarat	205.90	”	28/12/00
Russo, Julie – PO Box 152, Warracknabeal	147.00	”	23/05/00
Schreiner, S L – 4 Tambo Crt, Corio	184.25	”	07/06/00
Waldon, S – 7/56–58 Boford Rd, Croydon	183.07	”	22/02/01
Xerri, R – 935 Ballarat Rd, Deer Park	107.00	”	16/03/00

02034

CONTACT: MR DAVID WHELAN, PHONE (03) 9661 6109

Unclaimed Moneys Act 1962

Register of Unclaimed Moneys held by the —

Name of Owner on Books and Last Known Address	Total Amount Due to Owner	Description Of Unclaimed Money	Date when Amount first became Payable
COMPUTERSHARE LIMITED/CPU			
\$			
Mr Leung Yee Fun, 10 Martin Avenue, Remuera, Auckland, New Zealand	150.00	Cheque	28/03/00
Mrs Marguerite Anne Isaacson, Highgate Hill, Toorak	400.00	”	”
Dr Henry Salvatore Kristall, “Henry S. Kristall S/Fund A/C”, 2A Fifth Ave, St Peters SA	112.00	”	29/09/00
Rosevale (Aust) Pty Ltd, “Stephen M. Gillon Family A/C”, PO Box 25, Collins Street West, Melbourne	527.50	”	”
Mr Danny Selak, 5 Tregarron Avenue, Kew	160.00	”	”
Mr Milan Selak, 5 Tregarron Avenue, Kew	100.00	”	”
Mr Dean Michael Stanley, C/- Morrows Pty Ltd, 13/222 Kingsway, South Melbourne	110.00	”	28/03/00
Mrs Shirley Ann Thornton, 17 Moruben Rd, Mosman, NSW	100.00	”	28/09/99
Mrs Tricia Welsh, 48 Somers Avenue, Malvern	100.16	”	29/09/00

02062

CONTACT: BIRUTA KLIUKAS, PHONE: (03) 9235 5540.

Unclaimed Moneys Act 1962

Register of Unclaimed Moneys held by the —

<i>Name of Owner on Books and Last Known Address</i>	<i>Total Amount Due to Owner</i>	<i>Description Of Unclaimed Money</i>	<i>Date when Amount first became Payable</i>
MAROONDAH CITY COUNCIL			
	\$		
A. M. Findlay, Lot 1, Maroondah Parade, Healesville	225.00	Cheque	28/11/00
Amaytron, 5 Laser Drive, Rowville	225.00	"	16/02/01
Beverley Homes, 836 Mt Dandenong Road, Montrose	225.00	"	"
Dandridge P/L, 405 Maroondah Highway, Ringwood	225.00	"	"
Dantella Pty Ltd, PO Box 159, Narre Warren	225.00	"	"
Fisher Building Services P/L, 73 Rachelle Drive, Wantirna	225.00	"	28/11/00
Hollensen Timber & Fencing, 519 Mountain Highway, Bayswater	225.00	"	"
Integra Homes, 68 Bellbird Road, Mt Eliza	225.00	"	"
Morris & Son Construction, 4, 19-21 Karingal Street, Croydon North	280.00	"	16/02/01
Petro Installations & Maintenance, 3 Centre Rd, Dandenong	300.00	"	"

02143

CONTACT: ROSS DUFTY, PHONE: (03) 9298 4268.

Unclaimed Moneys Act 1962

Register of Unclaimed Moneys held by the —

<i>Name of Owner on Books and Last Known Address</i>	<i>Total Amount Due to Owner</i>	<i>Description Of Unclaimed Money</i>	<i>Date when Amount first became Payable</i>
PHILIP MORRIS LIMITED			
	\$		
Nightowl Bondi Junction, 18 Bronte Road, Bondi Junction, NSW	2,865.70	Cheque	15/03/99
Anastasia Nemeruck, 21 Cypress Road, St Marys, NSW	279.00	"	06/05/99
Supa Valu Woodlands, Shop 22, Woodlands Shopping Centre, Woodlands, WA	415.10	"	18/06/99
Wagin Roadhouse, 17 Tudhoe Street, Wagin, WA	307.85		16/02/99

02148

CONTACT: CHRISTINE CAMPBELL, PHONE: (03) 8531 1238.

Unclaimed Moneys Act 1962

Register of Unclaimed Moneys held by the —

<i>Name of Owner on Books and Last Known Address</i>	<i>Total Amount Due to Owner</i>	<i>Description Of Unclaimed Money</i>	<i>Date when Amount first became Payable</i>
PACIFIC HYDRO LIMITED			
	\$		
Mr Paolo Acconci, Unit 1-3 G/F Block 4, 18 Tin Hau Road, Nan Fung Industrial City, Tuen Mun NT, Hong Kong	105.00	Cheque	09/11/00
Mr Hugh Higham Wigg, 6 The Mews, Walkerville, SA	142.86	"	14/04/00
Mr Hugh Higham Wigg, 6 The Mews, Walkerville, SA	142.86	"	09/11/00
Dr Andrew James Latham Harkness, Harkness Employees S/F A/c, C/- 31 Jackson Street, Toorak	150.00	"	14/04/00
Mr Lyle Walter Walker, 1 Officer Avenue, Blackwater, Qld	150.00	"	"

02071

CONTACT: GEOFF GRAY, PHONE: (03) 9615 9910.

Unclaimed Moneys Act 1962

Register of Unclaimed Moneys held by the —

<i>Name of Owner on Books and Last Known Address</i>	<i>Total Amount Due to Owner</i>	<i>Description Of Unclaimed Money</i>	<i>Date when Amount first became Payable</i>
WESFARMERS LANDMARK			
	\$		
Garfield Park, RMS 994, Lockington	119.50	Cheque	25/06/99
A. Startseff, 51 Bailey Rd, Narre Warren	493.41	"	15/07/99
Spencer Miller, East Leigh, Willaura	108.00	"	19/10/99
Hamilton P. & A. Society, PO Box 276 Hamilton	500.00	"	26/11/99
AWB Limited, GPO Box 4562, Melbourne	100.00	"	02/02/00
G.L. & D.F. Sampson, PO Box 11. Tungamah	943.89	"	14/02/00
A. & V. Stafford Transport, RMB 4150, Benalla	267.19	"	26/02/00
Sale Stock Yards, PO Box 1132, Sale	100.00	"	23/03/00
D.J. Heffernan, Post Office Waaia	311.94	"	28/03/00
G.F. Hutchins, 84 Colliver Rd, Shepparton	129.41	"	06/04/00
A. & J. Boast, RMB 7390, Calrossie Rd, Won Wron	268.81	"	19/04/00
Mark Gilbert, Lot 27, Sth Gippsland Hwy, Sale	108.31	"	24/05/00
N.L. & C.Y. Williams, 560 Soldiers Rd. Waratah North	5,322.45	"	29/05/00
J.D. Earle, 2 Church Street. Stawell	376.64	"	07/06/00
Ken Kuhnell, Mardan Rd, Leongatha	304.94	"	12/06/00
P.J. & M.T. Collins, Tenneyson South Rd. Tenneyson	166.53	"	13/06/00
Inglemar Past Co, Ingleburn. Walbundrie, NSW	910.10	"	23/06/00
F.R. & M.E. Laidlaw, ERMB 2030, Strathmerton	476.65	"	"

M.A. & C.I. Bennett, PO Box 16, Lalbert	445.18	''	03/07/00
G.C.R. & M. Kuthne, Farmers Rd, Dumbalk	371.12	''	10/07/00
R.H. & C.F. Hargreaves, 74 Hume Street. Yarrawonga	592.58	''	17/07/00
G. & C. Warren, RMB 5000, Heyfield	181.11	''	19/07/00
V.T. Carter, 204 Burnbank Street. Wendouree	127.37	''	20/07/00
Kim Gear, 34 Karingal Street, Croydon	3,355.77	''	10/08/00
S.G. & J.A. Batchelor, RMB 5760, Riverview Rd, Heyfield	662.66	''	13/09/00
City of Warrnambool, PO Box 198, Warrnambool	179.16	''	21/09/00
Neil Adams Livestock, PO Box 218, Kyneton	229.90	''	26/09/00
S.D. & K.A. Brister, Post Office. Yinnar	104.17	''	28/09/00
J.C. Whitehead & Co, RMB 9572, Warrnambool	3,441.60	''	25/10/00
Est F.A. & H.S. Creed, RMB 9195. Garvoc	160.67	''	''
Yinnar Transport, PO Box 38, Yinnar	250.80	''	27/11/00
J. & S. Hutchinson, RMB 6510, Mansfield	156.75	''	''
Coles Supermarkets Australia,			
Logistics Accounting Meat Dept, PO Box 480, Glen Iris	773.49	''	08/12/00
Turriff West Hall, C/- Max Jolly Turriff Via Speed	167.69	''	12/12/00
Warragul Regional College, PO Box 213, Warragul	707.12	''	14/12/00
A.E. Whittington, Mackinnons Bridge,			
6203 Princes Highway, Terang	481.36	''	15/12/00
J. Boast, PO Box 220, Traralgon	100.45	''	20/12/00
A. Riches, RMB 5138, Kawarren	359.14	''	04/01/01
C. Moylan, Tipperary Station. 73 Dunbar Rd. Traralgon	152.41	''	17/01/01
Carlos Minichiello, 48 Anzac Rd, Trafalgar	1,070.60	''	02/02/01
Carlos Minichiello, 48 Anzac Rd, Trafalgar	272.07	''	08/02/01
J.P. Seymour, RMB 5445, Wangaratta	1,707.60	''	''
R.M. & G. Pearson, RMB 110, Streatham	13,367.87	''	16/02/01
Associated Marine Insurer, GPO Box 1337L, Melbourne	1,247.40	''	21/02/01
Carlos Minichiello, 48 Anzac Rd, Trafalgar	697.26	''	22/02/01
Dwyer Bros, 3 Webb Drive, Wonthaggi	135.85	''	26/02/01

02059

CONTACT: EMMA BOURKE, PHONE: (02) 8833 6561.

Unclaimed Moneys Act 1962

Register of Unclaimed Moneys held by the —

<i>Name of Owner on Books and Last Known Address</i>	<i>Total Amount Due to Owner</i>	<i>Description Of Unclaimed Money</i>	<i>Date when Amount first became Payable</i>
YHA VICTORIA			
	\$		
Peter Moloney	107.45	Cheque	15/09/00

02057

CONTACT: NIKKI MASON, PHONE: (03) 9670 3802.

PROCLAMATIONS

ACTS OF PARLIAMENT

Proclamation

I, John Landy, Governor of Victoria, declare that I have today assented in Her Majesty's name to the following Bill:

No. 14/2002 **Health Practitioner Acts
(Further Amendments) Act
2002**

Given under my hand and the seal of Victoria at Melbourne on 7 May 2002.

(L.S.) JOHN LANDY
Governor
By His Excellency's Command

STEVE BRACKS
Premier

This Proclamation is effective from the date on which it is published in the Government Gazette.

Given under my hand and the seal of Victoria on the 7 day of May 2002.

(L.S.) JOHN LANDY
Governor

By His Excellency's Command

SHERRYL GARBUTT MP
Minister for Environment
and Conservation

- No. 14/2002 (1) This section and sections 1, 31, 38, 43, 45, 46, 47, 48 and 49 come into operation on the day after the day on which this Act receives the Royal Assent.
- (2) Subject to sub-section (3), the remaining provisions of this Act come into operation on a day or days to be proclaimed.
- (3) If a provision of this Act does not come into operation before 30 June 2004, it comes into operation on that day.

Land Act 1958

PROCLAMATION OF ROAD

I, John Landy, Governor of Victoria with the advice of the Executive Council and under section 25(3)(c) of the **Land Act 1958** proclaim as road the following land:

MUNICIPAL DISTRICT OF THE
WELLINGTON SHIRE COUNCIL

YARRAM YARRAM — Crown Allotment 2004, Parish of Yarram Yarram as shown by green outline on Plan LEGL./01-123 lodged in the Central Plan Office. — (2011718).

**GOVERNMENT AND OUTER BUDGET SECTOR AGENCIES
NOTICES**



Knox City Council
Serving the People of Knox

ERRATUM

**Discontinuance of a Section of
Reservoir Crescent, Rowville**

In the Government Gazette G48, 30 November 2000, page 2803, the Discontinuance of a section of Reservoir Crescent, Rowville, was advertised excluding dimension details. The area to be closed, together with dimensions, is indicated below.

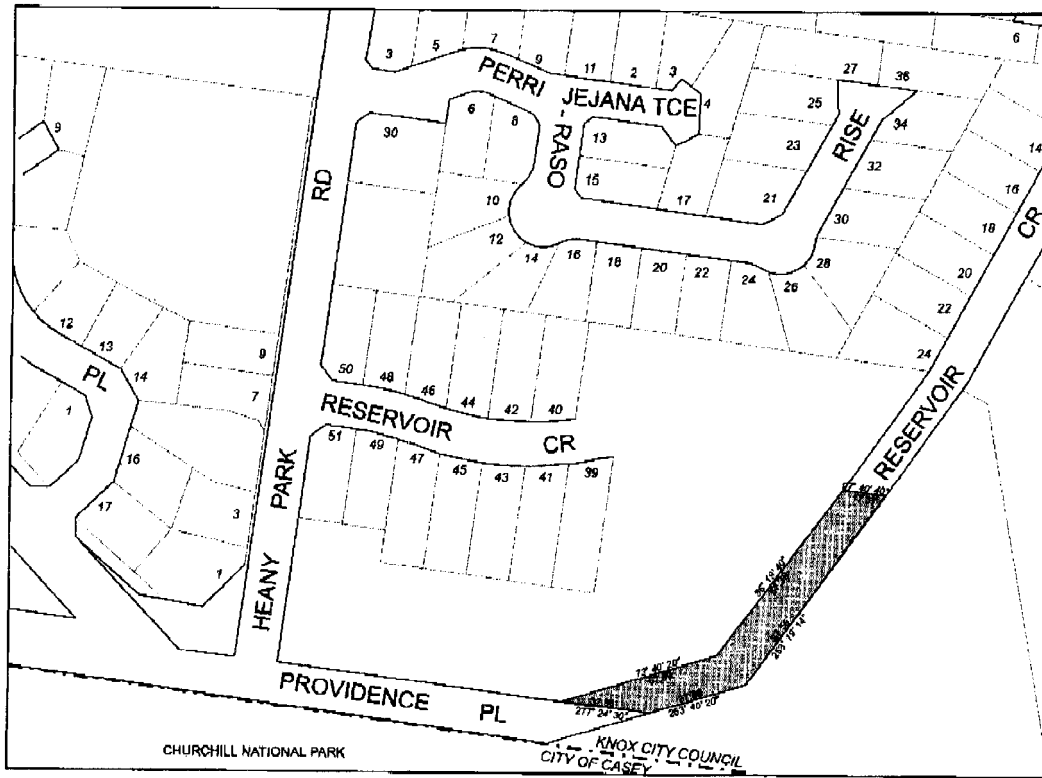

PROPOSED ROAD CLOSURE SHOWN THUS:

PLAN NOT TO SCALE

GRAEME EMONSON
Chief Executive Officer



PROCEDURAL MATTERS
LOCAL LAW 2002

Notice is hereby given that at a meeting of the Knox City Council on 23 April 2002, Council made and adopted the Procedural Matters Local Law 2002 pursuant to Section 119(3) of the **Local Government Act 1989**. The purpose of the Local Law is to:

- a) regulate the use and control of Council's common seal;
- b) prohibit unauthorised use of the common seal or any device resembling the common seal;
- c) regulate the proceedings of the election of Mayor;
- d) regulate the proceedings of ordinary and special meetings of Council;
- e) provide penalties for non-observance of the provisions of the Local Law;
- f) authorise charging of fees as permitted by the Act and generally maintain the peace, order and good government of the municipal district.

The general purport of the Local Law is – Part A – Introduction – Procedural matters relating to the Local Law.

Part B – Council's Common Seal – Regulating the use of the common seal and providing authority to affix the common seal subject to delegations of Council.

Part C – Election of Mayor – This part provides the process in which the Mayor shall be elected including the eligibility for the position of Mayor. It proposes the Chief Executive Officer will act as Returning Officer in the conduct of elections and sets down the process that must be followed by the Chief Executive Officer in declaring the position of Mayor. This Part also deals with the provisions relating to nominations for temporary Chairpersons in the event of the Mayor not being in attendance.

Part D – Meeting Provisions – This part deals with the prescription on how ordinary and special meetings of Council should be conducted.

A copy of this Local Law is available for inspection from the City Offices, 511 Burwood Highway, Wantirna South.

The Procedural Matters Local Law 2002 came into operation on 1 May 2002.

GRAEME EMONSON
Chief Executive Officer



CITY OF KINGSTON
ADOPTION OF AMENDMENTS TO
LOCAL LAW 5
(Environment and Amenities) –
Trees and Vegetation

Notice is hereby given that the Council of the City of Kingston has adopted an amending local law so as to amend its Environment and Amenities Local Law Number 5.

The purpose of the amending local law is to protect trees and vegetation within the municipal district, and to provide for the peace, order and good governance of the municipal district.

The general purport of the amending local law is to make it an offence for an owner or occupier of land to allow environmental weeds to be grown on that land, and will allow Council or an authorised officer to direct such persons to remove the weeds.

It is also now an offence to interfere with certain trees on private property, namely trees and vegetation which are listed in Council's Significant Tree and Vegetation Register, trees with a maximum trunk circumference greater than 110cm measured at their base and multi-stemmed trees where the sum total of their exterior stems equals a combined maximum trunk circumference greater than 110cm measured at their base. In particular, a person must not remove, damage, destroy, prune, cut, trim or carry out works near such trees or vegetation, or direct, authorize or allow any

such acts to be done, without a permit. The owner of private property on which such trees or vegetation are located is also guilty of an offence in these circumstances unless the owner can prove that the interference was undertaken by another party without authorisation. Council or an authorised officer may direct persons to replace a tree or vegetation that has been interfered with.

A copy of Local Law 5 (as amended) may be inspected (or purchased for the sum of \$2.00) at the City of Kingston Municipal Office, corner Brindisi Street and Mentone Parade, during business hours.

ROB SKINNER
Chief Executive Officer

MACEDON RANGES SHIRE COUNCIL
Public Holidays Act 1993

In accordance with the **Public Holidays Act 1993**, the Macedon Ranges Shire Council declares:-

- (a) a full day holiday for Tuesday 5 November 2002 in that part of the municipal district of the Macedon Ranges Shire Council that was the former Shire of Newham and Woodend, Romsey and Gisborne. The purpose of this holiday is in recognition of Melbourne Cup Day.
- (b) a full day holiday for Wednesday 6 November 2002 in that part of the municipal district of Macedon Ranges Shire Council that was the former Shire of Kyneton. The purpose of this holiday is in recognition of Kyneton Cup Day.

BAYSIDE CITY COUNCIL

Road Discontinuance

At its meeting on 8 April 2002 and acting under Clause 3 of Schedule 10 to the **Local Government Act 1989** Bayside City Council resolved to discontinue the road shown hatched on the plan below.

The road is to be sold subject to any right, power or interest held by Bayside City Council and South East Water Limited in the road in connection with any sewers, drains or pipes under the control of those authorities in or near the road.

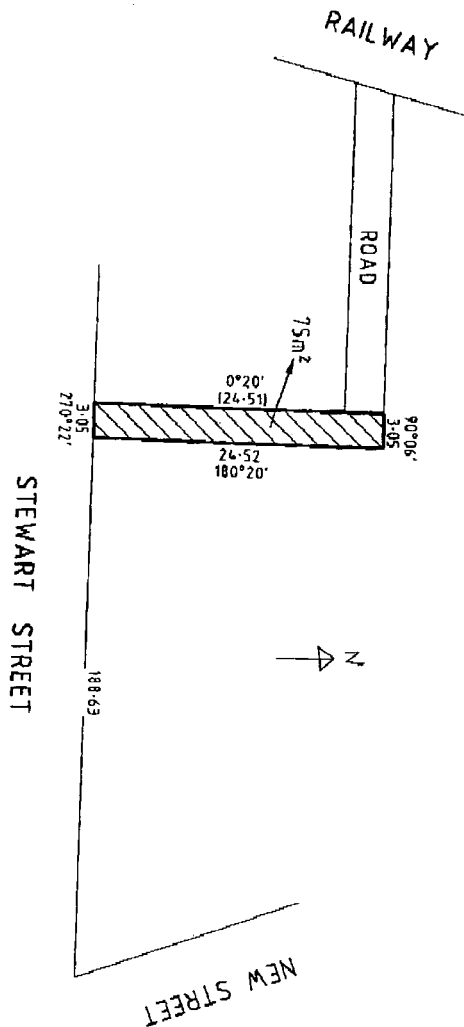

I. WILSON
Chief Executive

WHITEHORSE CITY COUNCIL

Road Discontinuance

Under Section 206 and Schedule 10, Clause 3 of the **Local Government Act 1989** the Whitehorse City Council at its Ordinary meeting held on 26 August 2000, formed the opinion that the sections of road shown cross-hatched on the plan below are not reasonably required as a road for public use and has resolved to discontinue the sections of road and to sell the land from the sections of road by private treaty subject to any right, power or interest held in the road by the Melbourne Water Corporation (Yarra

- introducing an Environmental Audit Overlay in accordance with Ministerial Direction No. 1 where a site is rezoned from the Industrial 1 Zone or the Industrial 3 Zone to a non-industrial zone, and
- introducing a Design and Development to 2-2A High Street, Northcote.

The Amendment is available for public inspection, free of charge and during office hours unless specified otherwise, at the following places: Darebin Municipal Offices, Strategic Planning Counter, City of Darebin, Level 1, 274 Gower Street, Preston 3072; Department of Infrastructure, Customer Service Centre, Upper Plaza, Nauru House, 80 Collins Street, Melbourne 3000; Northland Customer Service Centre, (Next to RACV), Northland Shopping Centre, Murray Road, Preston 3072. Also open on Saturday 9am – 12pm in addition to normal office hours; Northcote Customer Service Centre (next to Northcote Library), 32–38 Separation Street, Northcote 3070; Fairfield Library, 121 Station Street, Fairfield 3078. Opening Hours: Monday to Wednesday, Friday 10am – 5pm, Thursday 10am – 8pm, Saturday 10am – 1pm; Reservoir Library, 17–21 Ralph Street, Reservoir 3073. Opening Hours: Monday to Thursday 10am – 8pm, Friday 10am – 5pm, Saturday 10am – 4pm.

The Amendment can also be viewed online at www.darebin.vic.gov.au.

Any person or agency who may be affected by the Amendment can make a submission to the City of Darebin. Submissions about the Amendment must be sent to City of Darebin, PO Box 91, Preston 3072, by the close of business on 8th July 2002. Alternatively, an electronic submission may be submitted to ccheal@darebin.vic.gov.au.

Please contact Chris Cheal, Strategic Planner on 9230 4526 with any questions.

JOHN VAN AS
Manager Urban Development



Planning and Environment Act 1987
GREATER GEELONG PLANNING SCHEME
Notice of Amendment
Amendments C32 & C45

The City of Greater Geelong has prepared Amendments C32 & C45 to the Greater Geelong Planning Scheme.

Amendment C32

The Amendment proposes to amend the Greater Geelong Planning Scheme by rezoning approximately 34 hectares of land on the south side of Portarlinton Road, east of Christies Road, north of the Bellarine Rail Trail, Leopold from Rural zone to Residential 1 zone and inclusion of a Development Plan Overlay and Environmental Audit Overlay.

Amendment C45

The Amendment proposes to amend the Greater Geelong Planning Scheme by rezoning land situated at Lot 1 P.S. 502738 Plantation Road, Lovely Banks from Rural zone to Rural Living zone.

The Amendment can be inspected at City of Greater Geelong, Ground Floor, 131 Myers Street, Geelong 3220; Department of Infrastructure, Office of Planning, 180 Fyans Street, South Geelong 3219 and Department of Infrastructure, Level 3 Plaza, Nauru House, 80 Collins Street, Melbourne 3000.

Submissions about the Amendment must be sent to the Planning Scheme Unit, City of Greater Geelong, PO Box 104, Geelong 3220, by Tuesday 12 June 2002

IAN McCARTNEY
Co-Ordinator Strategic Planning

Planning and Environment Act 1987

MONASH PLANNING SCHEME

Notice of Amendment

Amendment C19

Planning Application TPA/28983

The City of Monash has prepared Amendment C19 to the Monash Planning Scheme.

The Amendment affects land situated at the northern end of Settler Court Glen Waverley.

The Amendment proposes to rezone the subject land from Public Use Zone Local Government (PUZ 6) to Residential 1 Zone with an Environmental Audit Overlay. A proposed planning permit for residential subdivision & removal of 'reserve' status over part of the land accompanies the Amendment.

The Amendment, associated documentation and proposed Planning Permit No. 28983, can

be inspected free of charge, during office hours at the Department of Infrastructure, Planning Information Centre, Upper Plaza, Nauru House, 80 Collins Street, Melbourne and at the offices of the Monash City Council, 293 Springvale Road, Glen Waverley.

Submissions about the amendment must be sent to the City of Monash, PO Box 1, Glen Waverley 3150 by 17 June 2002.

DAVID CONRAN
Chief Executive Officer
Monash City Council

Planning and Environment Act 1987

YARRA PLANNING SCHEME

Notice of Amendment

Amendment C39

The Yarra City Council has prepared Amendment C39 to the Yarra Planning Scheme.

The Amendment affects all land covered by the Development Plan Overlay Nos. 1, 2, 3, 5 and 9, under the Yarra Planning Scheme. The land is generally located at:

- 88 Wellington Street, Collingwood (part of the 'Yorkshire Brewery' site);
- 1-21 Robert Street, Collingwood (part of the 'Yorkshire Brewery' site);
- 115 Victoria Parade, Fitzroy (part of the Australian Catholic University campus);
- 20-26 Brunswick Street, Fitzroy (part of the Australian Catholic University campus);
- 28 Young Street, Fitzroy (part of the Australian Catholic University campus);
- 22-52 Bendigo Street, Richmond (part of the GTV Channel 9 site);
- 107-175 Stawell Street, Richmond (part of the GTV Channel 9 site);
- 416 Gore Street, Fitzroy;
- 29-35 York Street, Richmond.

The Amendment proposes to delete the Development Plan Overlay from the subject land. This means deleting Schedules 1, 2, 3, 5 and 9 from Clause 43.04 of the Yarra Planning Scheme and deleting the associated Development Plan Overlay maps.

The purpose of the Amendment is to update the Yarra Planning Scheme by deleting the Development Plan Overlay (DPO) control where it has become redundant. The control has become redundant where:

- the development supported by the DPO has been constructed in accordance with planning approvals; or
- the development has been granted a planning permit in accordance with the development plan (in which case the planning permit controls development and the DPO is no longer required), and the permit is still valid; or
- the development supported by the DPO is not going to proceed (in which case the DPO is a legal impediment prohibiting Council from determining permit applications for alternative developments); or
- future developments can be appropriately managed by the zone provisions (including implementation of the relevant sections of the Municipal Strategic Statement and local planning policies) and any other overlay controls that apply to the site.

The Amendment and associated documentation can be inspected at: Department of Infrastructure, Customer Service Centre, Upper Plaza, Nauru House, 80 Collins Street, Melbourne 3000; City of Yarra, Richmond Town Hall, Town Planning Counter, 333 Bridge Road, Richmond 3121 and City of Yarra, Collingwood Town Hall, Reception Desk, 140 Hoddle Street, Abbotsford 3067.

Submissions regarding the Amendment must be in writing and sent to: Tracy Watson, Senior Strategic Planner, City of Yarra, PO Box 168, Richmond, Vic. 3121 by 7 June 2002.

PETER GASCHK
Manager Urban Planning

STATE TRUSTEES LIMITED

ACN 064 593 148

Section 79

Notice is hereby given that State Trustees Limited, ACN 064 593 148 intends administering the estates of:-

PETER GLENN WILLIAM DAVEY, late of 53 Elstone Avenue, Airport West, Victoria, pensioner, deceased intestate, who died 20 April 2001.

MYRNA HAY, late of Violet Town Nursing Home, Cowslip Street, Victoria, pensioner, deceased, who died 12 January 2002.

Creditors, next-of-kin and others having claims against the abovementioned estates are required pursuant to Section 33 of the **Trustee Act 1958** to send particulars of their claims against the abovementioned estates to State Trustees Limited, 168 Exhibition Street, Melbourne, Victoria, on or before 11 July 2002 after which date State Trustees Limited, ACN 064 593 148, may convey or distribute the assets of the abovementioned estates having regard only to the claims of which it then has notice.

EXEMPTION

Application No. A61 of 2002

The Victorian Civil and Administrative Tribunal has considered an application pursuant to Section 83 of the **Equal Opportunity Act 1995** by Fiona Jay Phillips. The application for exemption is to enable the applicant to conduct a massage therapy clinic for women only.

Upon reading the material submitted in support of the application the Tribunal is satisfied that it is appropriate to grant an exemption from Sections 42, 100 and 195 of the Act to enable the applicant to conduct a massage therapy clinic for women only.

In granting this exemption the Tribunal noted:

- the applicant's practice provides services in relation to women's health such as massage during and after pregnancy, for premenstrual syndrome or stress, for menopause and for tension related post natal depression;
- the service will provide female clients with massage from female therapists in a non-threatening environment;
- the applicant proposes to operate the business from her home and regards the need to protect her personal safety in this environment as a significant consideration;
- the applicant was previously granted an exemption which expired on 28 October 2001.

The Tribunal hereby grants an exemption to the applicant from the operation of Sections 42, 100 and 195 of the **Equal Opportunity Act 1995** to enable the applicant to conduct a massage therapy clinic for women only.

This exemption is to remain in force from

the day on which notice of the exemption is published in the Government Gazette until 8 May 2005.

Dated 6 May 2002

Ms CATE McKENZIE
Deputy President

EXEMPTION

Application No. A69 of 2002

The Victorian Civil and Administrative Tribunal has considered an application pursuant to Section 83 of the **Equal Opportunity Act 1995** by the Riding for the Disabled Association of Victoria Inc (RDAV). The application for exemption is to enable the applicant's coaches to refuse to allow a person to ride any of the applicant's horses if the coach considers that because of the person's weight, height, build, balance or size or because of the height, size, weight, age, condition or build of the horse, it would be unsafe for the person to ride that horse or for the horse to carry that person.

Upon reading the material submitted in support of the application, the Tribunal is satisfied that it is appropriate to grant an exemption from Sections 42, 60, 65, 100 and 195 of the Act to enable the applicant's coaches to refuse to allow a person to ride any of the applicant's horses if the coach considers that because of the person's weight, height, build, balance or size or because of the height, size, weight, age, condition or build of the horse, it would be unsafe for the person to ride that horse or for the horse to carry that person.

In granting this exemption the Tribunal noted:

- the application is to allow qualified equestrian coaches to refuse to accept potential riders if they are assessed as being too heavy for the horses available. The relationship of rider weight is a matter of judgement and not something that can be strictly qualified because of a number of variables including the size, build, age and condition of the horse and the weight, symmetry and balance of the rider;
- the applicant's horses are generally aged and passed on to RDAV because they can no longer perform as their owners would wish and are generally calmer and more patient

than younger horses. Riders with disabilities generally sit heavier than able-bodied riders.

- RDAV prefers to use horses that are not too large as it is often necessary for safety reasons for helpers to walk on either side of the horse to stabilize the rider;
- each of the horses needs to be able to be used for a number of riders and it is not always possible to have a horse that will suit a particular individual's needs;
- the applicant was previously granted an exemption which expired on 14 April 2002.

The Tribunal hereby grants an exemption to the applicant from the operation of Sections 42, 60, 65, 100 and 195 of the **Equal Opportunity Act 1995** to enable the applicant's coaches to refuse to allow a person to ride any of the applicant's horses if the coach considers that because of the person's weight, height, build, balance or size or because of the height, size, weight, age, condition or build of the horse, it would be unsafe for the person to ride that horse or for the horse to carry that person.

This exemption is to remain in force from the day on which notice of the exemption is published in the Government Gazette until 8 May 2005.

Dated 6 May 2002

Ms CATE McKENZIE
Deputy President

EXEMPTION

Application No. A108 of 2002

The Victorian Civil and Administrative Tribunal has considered an application pursuant to Section 83 of the **Equal Opportunity Act 1995** by the Glen Waverley Secondary College. The application for exemption is to enable the applicant to advertise for and employ a female teacher at the applicant's rural campus.

Upon reading the material submitted in support of the application the Tribunal is satisfied that it is appropriate to grant an exemption from Sections 13, 100 and 195 of the Act to enable the applicant to advertise for and employ a female teacher at the applicant's rural campus.

In granting this exemption the Tribunal noted:

- the applicant maintains a remote rural campus staffed by two full time teachers, one male and one female;
- the rural campus caters for both boys and girls in the 13 to 15 age group. Camp groups normally run for four or five days with the teachers supervising the students at night;
- there is a need to ensure that a female staff member is available at the rural campus to supervise female students.

The Tribunal hereby grants an exemption to the applicant from the operation of Sections 13, 100 and 195 of the **Equal Opportunity Act 1995** to enable the applicant to advertise for and employ a female teacher at the applicant's rural campus.

This exemption is to remain in force from the day on which notice of the exemption is published in the Government Gazette until 8 May 2005.

Dated 6 May 2002

Ms CATE McKENZIE
Deputy President

Department of Treasury and Finance

SALE OF CROWN LAND
BY PUBLIC AUCTION

Date of Auction: 24 May 2002 at 12 noon on site.

Reference: Kangaroo Flat Primary School Annexe.

Address of Property: Corner Church & View Streets, Kangaroo Flat.

Crown Description: Crown Allotment 10, Section 19, Township of Kangaroo Flat, Parish of Sandhurst.

Terms of Sale: Deposit 10%, Balance 60 days.

Area: 2959 square metres.

Officer Co-ordinating Sale: John Kostiw, Department of Education and Training, Property Branch, Level 2, 2 Treasury Place, East Melbourne 3002.

Selling Agent: Dungey Carter Ketterer Real Estate, 54 Mitchell Street, Bendigo 3550.

JOHN LENDERS MP
Minister for Finance

Adoption Act 1984

Under the functions and powers assigned to me by the Secretary, Department of Human Services under Section 10(2) of the **Community Welfare Services Act 1970** in relation to Section 5 of the **Adoption Act 1984**.

I, Terry Garwood, approve the following person under Section 5(1) and Section (2)(b) of the Act as approved counsellor for the purposes of Section 35 of the Act.

Ms Fiona Heggie, St Luke's Family Care, 175-187 Hargreaves Street, Bendigo, Victoria.

Dated 14 March 2002

TERRY GARWOOD
Regional Director
Loddon Mallee Region

Resources and Environment with Alan Kenneth Burstall in relation to Crown Allotment 17A, Parish of Mamengorook.

A copy of the Agreement is available for public inspection between the hours of 9.00 a.m. and 5.00 p.m. at the following offices of the Department of Natural Resources and Environment: Mildura Office, Department of Natural Resources and Environment, 1st Floor, Fire Station Arcade, Langtree Avenue, Mildura 3500 and Executive Services Branch, Department of Natural Resources and Environment, Level 16, 8 Nicholson Street, East Melbourne 3002.

CHLOE MUNRO
Secretary

Conservation, Forests and Lands Act 1987

NOTICE OF MAKING OF A LAND
MANAGEMENT CO-OPERATIVE
AGREEMENT

Notice is given under Section 80 of the **Conservation, Forests and Lands Act 1987** that a Land Management Co-operative Agreement has been entered into by the Secretary to the Department of Natural Resources and Environment with Alan Kenneth Burstall in relation to Crown Allotment 6A, Parish of Mamengorook.

A copy of the Agreement is available for public inspection between the hours of 9.00 a.m. and 5.00 p.m. at the following offices of the Department of Natural Resources and Environment: Mildura Office, Department of Natural Resources and Environment, 1st Floor, Fire Station Arcade, Langtree Avenue, Mildura 3500 and Executive Services Branch, Department of Natural Resources and Environment, Level 16, 8 Nicholson Street, East Melbourne 3002.

CHLOE MUNRO
Secretary

Conservation, Forests and Lands Act 1987

NOTICE OF MAKING OF A LAND
MANAGEMENT CO-OPERATIVE
AGREEMENT

Notice is given under Section 80 of the **Conservation, Forests and Lands Act 1987** that a Land Management Co-operative Agreement has been entered into by the Secretary to the Department of Natural

Dairy Act 2000

DAIRY FOOD SAFETY VICTORIA

Notice of proposed Code of Practice for
Dairy Food Safety

In accordance with Section 32 of the **Dairy Act 2000**, Dairy Food Safety Victoria intends to make the Code of Practice for Dairy Food Safety. It is proposed that the Code will set the minimum mandatory standard for the production, manufacture, storage and transport of milk and dairy foods to safeguard public health and must be used by all dairy premises in conjunction with the Food Standards Code.

A copy of the proposed Code of Practice for Dairy Food Safety can be obtained or inspected from Dairy Food Safety Victoria at 651 Victoria Street, Abbotsford, 3067 (phone: (03) 9426 5999) or at www.dairysafe.vic.gov.au.

Submissions on the proposal are invited and should set out the grounds for any objections to the proposed Code of Practice for Dairy Food Safety, and must be received by Dairy Food Safety Victoria by 7 June 2002. All submissions must be addressed to Joanne Patterson, Industry Services Manager, Dairy Food Safety Victoria, 651 Victoria Street, Abbotsford, or by mail to PO Box 548, Richmond, Vic. 3121, or by email to jpatterson@dairysafe.vic.gov.au.

JOANNE PATTERSON
Industry Services Manager

**Domestic (Feral and Nuisance)
Animals Act 1994**

NOTICE OF PROPOSAL TO MAKE A CODE
OF PRACTICE TO SPECIFY STANDARDS
FOR THE CONDUCT OF A DOMESTIC
ANIMAL BUSINESS

I, Keith Hamilton, Minister for Agriculture, give notice under Section 60 (1) of the **Domestic (Feral and Nuisance) Animals Act 1994** of a proposal to make the following code of practice.

- Code of Practice for the Operation of Greyhound Establishments.

A copy of the draft code of practice may be obtained from the Bureau of Animal Welfare, 475 Mickleham Road, Attwood 3049, the Customer Service Centre by phoning 136 186 (between 8.00 a.m. and 8.00 p.m.), the NRE Information Centre, Ground Floor, 8 Nicholson Street or the internet at <http://www.nre.vic.gov.au>.

Submissions on the draft code must be made within twenty-eight days from the publication of this notice to the Minister for Agriculture, PO Box 500, East Melbourne 3330.

KEITH HAMILTON
Minister for Agriculture

Geographic Place Names Act 1998

CORRIGENDUM

In the Victoria Government Gazette No. G17, 24 April 2002, page 767, under Notice of Registration of Geographic Names, the place name Woodlands Park should be excluded.

Office of the Registrar of Geographic Names.

c/-LAND VICTORIA

Level 15, Marland House,
570 Bourke Street,
Melbourne 3000

KEITH C. BELL
Registrar of Geographic Names

Penalty Interest Rate Act 1983

The penalty interest rate fixed by the Attorney-General under the **Penalty Interest Rate Act 1983**, commencing on 4 May 2002 is 12.25% per annum. The rate was previously fixed at 11.5%.



Heritage
VICTORIA

Heritage Act 1995

NOTICE OF REGISTRATION

As Executive Director for the purpose of the Heritage Act, I give notice under section 46 that the Victorian Heritage Register is amended by including the Heritage Register Number 1987 in the category described as a Heritage place:

Notched Log Cottage, 920 Nyora Poowong Road, Poowong, South Gippsland Shire Council.

EXTENT:

1. The land shown as L1 on Diagram 1987 held by the Executive Director.
2. The building known as the Log Cottage shown on diagram 1987 held by the Executive Director.

Dated 9 May 2002

RAY TONKIN
Executive Director



Heritage
VICTORIA

Heritage Act 1995

NOTICE OF REGISTRATION

As Executive Director for the purpose of the Heritage Act, I give notice under section 46 that the Victorian Heritage Register amended by including the Heritage Register Number 1986 in the category described as a Heritage place:

Janevale Bridge over the Loddon River, Tarnulla-Laancoorie Road, Laancoorie, Loddon Shire Council.

EXTENT:

1. All of the bridge known as the Janevale bridge and the commemorative stone as shown on diagram 1986 held by the Executive Director.
2. The land as shown on diagram 1986 held by the Executive Director.

Dated 9 May 2002

RAY TONKIN
Executive Director



Heritage Act 1995

NOTICE OF REGISTRATION

As Executive Director for the purpose of the Heritage Act, I give notice under section 46 that the Victorian Heritage Register is amended by including the Heritage Register Number 1835 in the category described as a Heritage place:

Block 19, Bonegilla Road, Bonegilla, Wodonga Rural City Council.

EXTENT:

1. All the buildings marked as follows on Diagram 1853 held by the Executive Director:

- B1 Ablutions Block (Building 68)
- B2 Recreation Room (Building 79)
- B3 Accommodation Hut (Building 80)
- B4 Accommodation Hut (Building 81)
- B5 Store (Building 82)
- B6 Accommodation Hut (Building 84)
- B7 Mess (Building 85)
- B8 Staff Flat (Building 91)
- B9 Tudor Hall (Building 93)
- B10 Toilet (Building 94)
- B11 Supervisor's Flat (Building 95)
- B12 Accommodation Hut (Building 96)
- B13 Administrative Offices (Building 97)
- B14 Nurse's Quarters (Building 98)
- B15 Accommodation Hut (Building 99)
- B16 Accommodation Hut (Building 100)
- B17 Accommodation Hut (Building 101)
- B18 Accommodation Hut (Building 102)
- B19 Staff Flat (Building 104)
- B20 Staff Flat (Building 105)
- B21 Boiler House (Building 107)
- B22 Laundry (Building 108)
- B23 Hume Club (Building 176)

2. All of the land marked as follows on Diagram 1853 held by the Executive Director:

Part of the land described as Lot 1 on Plan of Subdivision PS428597Y; L2 part of the

closed road itself part of Crown Allotment 70A Parish of Bonegilla County of Bogong.

3. All of the hard and soft landscaping features and remnants of accommodation of service buildings within the land marked L1 comprising roads, paths, concrete slabs, garden beds and mature native and exotic trees.

Dated 6 May 2002

RAY TONKIN
Executive Director

Nurses Act 1993

On 6 May 2002, a panel appointed by the Nurses Board of Victoria, found that Alan Francis Gatherer, identification number 97213, registered in division 2, had engaged in unprofessional conduct of a serious nature.

The panel determined that:

1. Pursuant to s. 48(2)(g) **Nurses Act 1993**, the nurse's registration be suspended for a period of 18 months expiring on 3 October 2003.
2. After 3 October 2003, the nurse may apply in writing for restoration of his registration, as if pursuant to s.13A of the Act.
3. Pursuant to s. 48(2)(e) of the Act, the following condition, limitation or restriction be imposed on the nurse's registration when it is restored pursuant to paragraph 2 of this determination:
 - (a) the nurse must undergo consultations and counselling for at least 12 months with a psychiatrist or psychologist ("counsellor") approved in writing by the Board, such consultations to occur at least once a month, or more often if the counsellor recommends.
4. After undergoing the consultations and counselling directed pursuant to paragraph 3 of this determination, the nurse may apply in writing to remove the condition imposed pursuant to that paragraph 3. That application must be accompanied by a written report from the counsellor of the consultations and counselling, which report must be satisfactory to the Board.
5. Pursuant to s.48(2)(d) of the Act, before the first anniversary of the restoration of his registration pursuant to paragraph 2 of this

determination, the nurse must undertake and satisfactorily complete further education in professional ethics for nurses, the course and institution chosen to be approved in writing by the Board before tuition commences.

LEANNE RAVEN
Chief Executive

Petroleum Act 1998

NOTICE OF APPLICATION FOR RETENTION LEASE

We have applied to the Minister administering the **Petroleum Act 1998** for a Retention Lease the particulars of which are set out below.

Name of each applicant: Santos (BOL) Pty Ltd and Beach Petroleum N.L.

Address of each applicant: Level 29, Santos House, 91 King William Street, Adelaide, SA 5000 and 25 Conyngham Street, Glenside, SA 5065.

Area of proposed Lease: Approximately 5.24 square kilometres.

Full description and precise locality of land: An area bounded by a line commencing at point 'A' approximately 11 kilometres north-west of the town of Peterborough with co-ordinates of longitude 142°49'16"E and latitude 38°30'39"S, thence east to longitude 142°50'08"E, south to latitude 38°30'57"S, east to longitude 142°50'39"E, south to latitude 38°31'19"S, east to longitude 142°51'34"E, and south to latitude 38°31'58"S, west to longitude 142°50'42"E, and north to latitude 38°31'46"S, west to longitude 142°50'14.97"E, thence approximately north to longitude 142°50'13.82"E and latitude 38°31'24.67"S, thence approximately west to longitude 142°49'44.71"E and latitude 38°31'25.46"S, thence approximately north-west to longitude 142°49'38.01"E and latitude 38°31'18.12"S, thence approximately west north-west to longitude 142°49'22.02"E and latitude 38°31'13.15"S, thence approximately north-west to longitude 142°48'39.12"E and latitude 38°30'44.26"S, north to latitude 38°30'20"S, east to longitude 142°48'46"E, north to latitude 38°30'17.50"S, east to longitude 142°49'16"E, and south to the point of commencement at 'A'.

All the above coordinates are expressed in AGD66.

Plan of the proposed Lease area showing main roads, rivers, creeks, Crown lands and property boundaries:

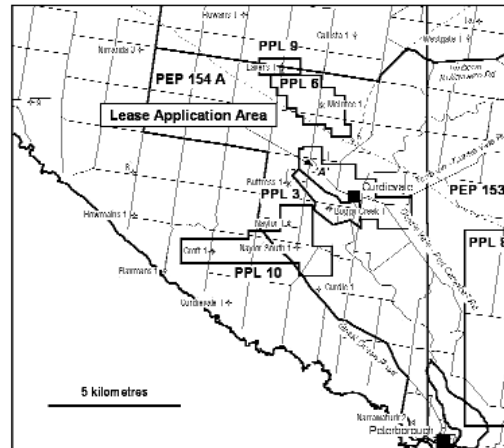

Nature of proposed Lease: Lease required to allow for evaluation of commercial viability of gas from the Buttress field.

Estimated term of Lease: Until surrendered by the company or cancelled by the Minister.

Names of applicants: Santos (BOL) Pty Ltd, ABN 35 000 670 575 and Beach Petroleum N.L., ABN 20 007 617 969.

Dated 19/3/2002

Petroleum Act 1998

NOTICE OF APPLICATION FOR PRODUCTION LICENCE

We have applied to the Minister administering the **Petroleum Act 1998** for a Production Licence the particulars of which are set out below.

Name of each applicant: Santos (BOL) Pty Ltd and Beach Petroleum N.L.

Address of each applicant: Level 29, Santos House, 91 King William Street, Adelaide, SA 5000 and 25 Conyngham Street, Glenside, SA 5065.

Area of proposed Licence: Approximately 2.54 square kilometres.

Full description and precise locality of land: An area bounded by a line commencing at point 'A' approximately 11 kilometres north-west of the town of Peterborough with co-ordinates of longitude 142°48'27.53"E and latitude 38°30'53.20"S, thence north to latitude

38°30'40"S, west to longitude 142°47'38"E, south to latitude 38°31'35"S, east to longitude 142°48'10"E, and north to latitude 38°31'30"S, east to longitude 142°49'00"E, and south to latitude 38°31'34.60"S, east to longitude 142°49'03.34"E, thence approximately north to longitude 142°49'04.50"E and latitude 38°31'26.20"S, thence approximately north-west to the point of commencement at 'A'.

All the above coordinates are expressed in AGD66.

Plan of the proposed Licence area showing main roads, rivers, creeks, Crown lands and property boundaries:

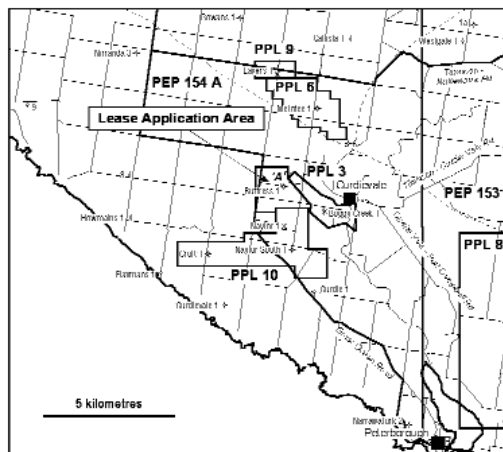

Nature of proposed Licence: Licence required to allow for production of gas from the Buttress field.

Estimated term of Licence: Until surrendered by the company or cancelled by the Minister.

Names of applicants: Santos (BOL) Pty Ltd, ABN 35 000 670 575 and Beach Petroleum N.L., ABN 20 007 617 969.

Dated 19/3/2002

Stamps Act 1958

NOTICE UNDER SECTION 40A

Pursuant to Section 40A of the **Stamps Act 1958** I hereby declare and make effective from 2 May 2002, that:

AP420 – KMA Legal Services Pty Ltd

to no longer be an "authorised person" in relation to the stamping of transfers of land, mortgages, bonds, debentures or covenants,

marketable securities, leases, agreements to lease, assignments or transfers of lease and instruments of settlement.

PAUL BRODERICK
Commissioner of State Revenue

Physiotherapists Registration Act 1998

FEES PAYABLE TO THE BOARD

In accordance with Section 85(1)(c) of the **Physiotherapists Registration Act 1998** the Board has fixed the following fees which will be payable to the Board from 1 May 2002:

Fee	\$
Endorsement of Registration	
Division 1	160.00
Division 2	210.00
Dated 1 May 2002	

M.E. STRICKLAND
Registrar

Water Act 1989

I, Sheryll Garbutt, Minister for Conservation and Environment, make the following Order:

CAMPASPE DEEP LEAD GROUNDWATER SUPPLY PROTECTION AREA BOUNDARY AMENDMENT ORDER 2001

1. This Order is called the Campaspe Deep Lead Groundwater Supply Protection Area Boundary Amendment Order 2001.

2. This Order is made under the powers conferred by Division 3 of Part 3 of the **Water Act 1989** and all other available powers.

3. This Order takes effect on and from the date it is published in the Government Gazette.

4. The purpose of this Order is to amend the boundary of the Campaspe Deep Lead Groundwater Supply Protection Area.

5. On and from the date on which this Order takes effect the area of the Campaspe Deep Lead Groundwater Supply Protection Area is the area of land shown within the red border on Plan No. LEGL./01-47.

6. Plan No. LEGL./01-47 referred to in clause 5 may be inspected at the office of Land and Survey Information Services – Department

of Natural Resources and Environment, 436 Lonsdale Street, Melbourne during business hours.

Dated 30 April 2002

SHERYLL GARBUTT
Minister administering the
Water Act 1989

Water Act 1989

SECTION 96

Coliban Region Water Authority

Declaration of Tylden Sewerage District

In accordance with the requirements of Section 96(7)(c) of the **Water Act 1989** notice is given of a proposed Tylden Sewerage District. This district will include the Tylden sewerage scheme and lands to the south and west of the Township including CAs 73 and 93 and parts of CAs 54 and 94.

Plans of the proposed district can be viewed at Coliban Water, 37–45 Bridge Street, Bendigo or Macedon Ranges Shire, 129 Mollison Street, Kyneton, free of charge, during office hours.

Submissions are invited from members of the public. Any person making a submission should set out the grounds for any objection raised in the submission.

Submissions should be sent to Ms Cheryl Fitzgerald, Corporate Secretary, Coliban Region Water Authority, Box 2770, Bendigo Delivery Centre, 3554 and must be received by the Authority within one month after publication of this notice in the Government Gazette.

Submissions must be received by 9 June 2002.

Water Act 1989

SECTION 96

Coliban Region Water Authority

Extension to Tylden Water District

In accordance with the requirements of Section 96(7)(c) of the **Water Act 1989** notice is given of a proposed extension of the Tylden Water District. It is proposed that the extension will include lands further to the south and west of the Township specifically CAs 73 and 93 and parts of CAs 54 and 94.

Plans of the proposed extension can be viewed at Coliban Water, 37–45 Bridge Street, Bendigo or Macedon Ranges Shire, 129 Mollison Street, Kyneton, free of charge, during office hours.

Submissions are invited from members of the public. Any person making a submission should set out the grounds for any objection raised in the submission.

Submissions should be sent to Ms Cheryl Fitzgerald, Corporate Secretary, Coliban Region Water Authority, Box 2770, Bendigo Delivery Centre, 3554 and must be received by the Authority within one month after publication of this notice in the Government Gazette.

Submissions must be received by 9 June 2002.

Health Services Act 1988

DECLARATION OF APPROVED
QUALITY ASSURANCE BODY

I declare the Patient Safety Committee, established by The Royal Victorian Eye & Ear Hospital, is an approved quality assurance body under Section 139 for the purposes of part 7 of the **Health Services Act 1988**.

Dated 19 April 2002

JOHN THWAITES
Minister for Health

Private Agents Act 1966

NOTICE OF RECEIPT OF APPLICATIONS
FOR LICENCES UNDER THE PROVISIONS
OF THE **PRIVATE AGENTS ACT 1966**

I, the undersigned, being the Registrar of the Magistrates' Court at Melbourne hereby give notice that applications, as under, have been lodged for hearing by the said Court on the date specified.

Any person desiring to object to any of such applications must:—

- (a) lodge with me a notice in the prescribed form of his objection and of the grounds thereof;
- (b) cause a copy of such notice to be served personally or by post upon the applicant at least three days before the hearing of the application; and

(c) send or deliver

- (i) where the objection is not made by the officer in charge of the police district in which the Court is situated — a copy of the notice to such officer; and
- (ii) where the objection is not made by the Registrar or Deputy Registrar — a copy to the Registrar.

<i>Full name of Applicant or in the case of a Firm or Corporation, of the Nominee</i>	<i>Place of Abode of Applicant or Nominee</i>	<i>Name of Firm or Corporation</i>	<i>Address for Registration</i>	<i>Type of Licence</i>	<i>Date of Hearing of Application</i>
Roman John Gizycki	8 Golden Fleece Place, Hoppers Crossing 3029	Collection House Ltd	477 Collins Street, Melbourne	Sub-Agent licence	29.05.02
Zoe Cortese	57 Harold Street, Bulleen	Collection House Ltd	477 Collins Street, Melbourne	Sub-Agent licence	29.05.02
Nicole Klouaris	21 Alison Street, Thomastown	Collection House Ltd	477 Collins Street, Melbourne	Sub-Agent licence	29.05.02
Lee John Dawson	8 Illawong Grove, Werribee	Collection House Ltd	477 Collins Street, Melbourne	Sub-Agent licence	29.05.02
Nina Haldar	5 Cipora Place, Thomastown	Collection House Ltd	477 Collins Street, Melbourne	Sub-Agent licence	29.05.02
Lina Aboul-Rahim	69 Gentles Avenue, Campbellfield	Collection House Ltd	477 Collins Street, Melbourne	Sub-Agent licence	29.05.02
Cihan Serder De Miri	94 Union Street, Brunswick	Collection House Ltd	477 Collins Street, Melbourne	Sub-Agent licence	29.05.02
Enrico Pellegrini	7/14 Hotham Street Hughesdale 3166	Collection House Ltd	477 Collins Street, Melbourne	Sub-Agent licence	29.05.02
Gregory Noel Lawes	3 Dougand Court, Dingley	Collection House Ltd	477 Collins Street, Melbourne	Sub-Agent licence	29.05.02
Julie Anne Robinson	2/806–808 Warrigal Road, Chadstone	Collection House Ltd	477 Collins Street, Melbourne	Sub-Agent licence	29.05.02

<i>Full name of Applicant or in the case of a Firm or Corporation, of the Nominee</i>	<i>Place of Abode of Applicant or Nominee</i>	<i>Name of Firm or Corporation</i>	<i>Address for Registration</i>	<i>Type of Licence</i>	<i>Date of Hearing of Application</i>
Trevor Jordon	510 Settlement Road, Sunbury	RCL Mercantile P/L	3/271 William Street, Melbourne	Commercial Agent	31.05.02
Christopher Holmes Richardson	47 Brownfield Street, Parkdale	College Mercantile P/L	479 St Kilda Road, Melbourne	Commercial Agent	04.06.02
Christopher Holmes Richardson	47 Brownfield Street, Parkdale	Dun & Bradstreet P/L	479 St Kilda Road, Melbourne	Commercial Agent	04.06.02
Pradidto Biswas	60 Moore Street, Footscray 3011	Advanced Credit Management	455 Bourke Street, Melbourne	Sub-Agent Licence	04.06.02

Dated at Melbourne 6 May 2002

OZNUR LINO
Registrar of the Magistrates' Court

Transport Act 1983
VICTORIAN TAXI DIRECTORATE
Department of Infrastructure
Commercial Passenger Vehicle Applications

Notice is hereby given that the following applications will be considered by the Victorian Taxi Directorate, a division of the Department of Infrastructure after 12 June 2002.

Notice of any objection to the granting of an application should be forwarded to reach the Manager, Licensing & Certification, Victorian Taxi Directorate, Level 6, 14-20 Blackwood Street, North Melbourne (PO Box 666, North Melbourne 3051) not later than 6 June 2002.

Copies of objections are forwarded to the applicants.

It will not be necessary for interested parties to appear on the date specified, unless advised in writing by the Department.

M. A. Troy, North Balwyn. Application for variation of conditions of licence SV1363 which authorises the licensed vehicle to operate in respect of a 1971 Mercedes Benz sedan with seating capacity for 4 passengers for the carriage of passengers for wedding parties and debutante balls to change the vehicle to the following:-

Make	Year of Manufacture	Seating Capacity
Mercedes Benz sedan/stretched limousine	1981 or later	11 or
Ford LTD sedan/stretched limousine	1989 or later	11 or
Ford Lincoln sedan/stretched limousine	1992 or later	11 or
Cadillac sedan/stretched limousine	1988 or later	11

And to include the ability to operate for school formals, birthdays, anniversaries, horse race meetings, Melbourne Grand Prix and restaurant packages.

M. A. Troy, North Balwyn. Application for variation of conditions of licence SV1855 which authorises the licensed vehicle to operate in respect of a 1989 Ford LTD stretched limousine with seating capacity of 12 or fewer seats for the carriage of passengers for wedding parties, debutante balls and schools to change the vehicle to the following:—

Make	Year of Manufacture	Seating Capacity
Mercedes Benz sedan/stretched limousine	1981 or later	11 or
Ford LTD sedan/stretched limousine	1989 or later	11 or
Ford Lincoln sedan/stretched limousine	1992 or later	11 or
Cadillac sedan/stretched limousine	1988 or later	11

And to include the ability to operate for birthdays, anniversaries, horse race meetings, Melbourne Grand Prix and restaurant packages.

T. A. Webb, Beechworth. Application for variation of licence granted but not yet taken up in respect of a 1990 or later model Toyota/Mitsubishi wagon with seating capacity for 7 passengers to operate a service from Diffey Road, Beechworth for the carriage of cyclists on trail rides from Murray to Mountains Rail Trail to include the ability to operate for the carriage of cyclists to various townships within a 50km radius of the Beechworth Post Office.

Note:— Passengers will be picked up/set down from within a 50km radius of the Beechworth Post Office.

B. H. Winters, Stawell. Application for variation of conditions of licence granted but not yet taken up which authorises the licensed vehicle to operate as follows:—

- (i) for the carriage of passengers to wedding parties, debutante balls, anniversaries and on tours to wineries within the Pyrenees, Halls Gap, Great Western and Ararat regions; and
- (ii) on tours to various places of interest within a 100km radius of the Stawell Post Office.

where the use of a 1959 Ford coupe or a 1963 Ford convertible is an essential feature of the hiring; To change the vehicle to a 1964 Buick convertible with seating capacity for five passengers.

Dated 9 May 2002

ROBERT STONEHAM
Manager Operations
Victorian Taxi Directorate

Education Act 1958

NOTICE OF MAKING OF AN ORDER UNDER SECTION 13

An Order of the Minister for Education and Training was made on 9 April 2002 pursuant to Section 13(4) of the **Education Act 1958** amending the constituting Order of the school council of the State school called Victorian School of Languages to change its address. The change is as follows:

Old address	New address
Corner of Albert and Canterbury Roads, South Melbourne	Corner of Clarendon and Sparks Avenue, Thornbury

LYNNE KOSKY
Minister for Education and Training

Planning and Environment Act 1987**BAW BAW PLANNING SCHEME**

Notice of Approval of Amendment

Amendment C15

The Minister for Planning has approved Amendment C15 to the Baw Baw Planning Scheme.

The Amendment comes into operation on the date this notice is published in the Government Gazette.

The Amendment:

- deletes the Public Acquisition Overlay from land acquired by VicRoads for the purpose of constructing the Nilma Interchange;
- rezones the areas of land occupied by the new interchange from Township Zone, Rural Zone and Public Use Zone – Transport to Road Zone 1;
- rezones the land on which the former railway crossing was located from Road Zone 1 to Public Use Zone – Transport;
- rezones a surplus strip of land owned by VicRoads land from Road Zone 1 to Township Zone.

A copy of the Amendment can be inspected, free of charge, during office hours, at the Department of Infrastructure, Planning Information Centre, Upper Plaza, Nauru House, 80 Collins Street, Melbourne and at the offices of the Baw Baw Shire Council, Civic Place, Warragul.

PAUL JEROME
Executive Director
Planning, Heritage and
Building Division
Department of Infrastructure

Planning and Environment Act 1987**CASEY PLANNING SCHEME**

Notice of Approval of Amendment

Amendment C43

The Minister for Planning has approved Amendment C43 to the Casey Planning Scheme.

The Amendment comes into operation on the date this notice is published in the Government Gazette.

The Amendment:

- rezones part of Lots 13, 18 & 19 on PS 411054K, Ormond Road, Hampton Park to Residential 1 Zone;
- rezones Lot A on PS 430080B, Golf Links Road, Berwick to Public Use Zone 1;
- rezones several lots on PS 430089G, Golf Links Road, Berwick to Residential 1 Zone;
- deletes Public Acquisition Overlay 4 from Lot A on PS 430080B and several lots on PS 430089G, Golf Links Road, Berwick;
- amends HO14 on Planning Scheme Map No. 22HO;
- amends Planning Scheme Map No. 8HO to show HO26;
- amends the schedule to the Heritage Overlay.

A copy of the Amendment can be inspected, free of charge, during office hours, at the Department of Infrastructure, Customer Service Centre, Upper Plaza, Nauru House, 80 Collins Street, Melbourne and at the offices of the Casey City Council, Princes Highway, Narre Warren.

PAUL JEROME
Executive Director
Planning, Heritage and
Building Division
Department of Infrastructure

Planning and Environment Act 1987**GANNAWARRA PLANNING SCHEME**

Notice of Approval of Amendment

Amendment C2

The Minister for Planning has approved Amendment C2 to the Gannawarra Planning Scheme.

The Amendment comes into operation on the date this notice is published in the Government Gazette.

The Amendment makes fourteen minor and corrective alterations to the Gannawarra Planning Scheme, including:

- six minor adjustments to the Floodway/LSIO boundary;
- five minor rezonings to accord with ownership and existing use, and
- rewording of three ordinance provisions.

A copy of the Amendment can be inspected, free of charge, during office hours, at the Department of Infrastructure, Customer Service Centre, Upper Plaza, Nauru House, 80 Collins Street, Melbourne and Northern Regional Office, 57 Lansell Street, Bendigo and at the Gannawarra Shire Council, Kerang Service Centre, 49 Victoria Street, Kerang and Cohuna Service Centre, 23–25 King Edward Street, Cohuna.

PAUL JEROME
Executive Director
Planning, Heritage and
Building Division
Department of Infrastructure

Planning and Environment Act 1987
QUEENSCLIFFE PLANNING SCHEME
Notice of Approval of Amendment
Amendment C11

The Minister for Planning has approved Amendment C11 to the Queenscliffe Planning Scheme.

The Amendment comes into operation on the date this notice is published in the Government Gazette.

The Amendment:

- replaces and renumbers all causes contained with the Local Planning Policy Framework;
- corrects general anomalies in the Local Planning Policy Framework; and
- substitutes a new schedule 2 and 3 in the Design and Development Overlay.

A copy of the Amendment can be inspected, free of charge, during office hours, at the Department of Infrastructure, Planning Information Centre, Upper Plaza, Nauru House, 80 Collins Street, Melbourne and at the offices of the Borough of Queenscliffe, 50 Learmonth Street, Queenscliff.

PAUL JEROME
Executive Director
Planning, Heritage and
Building Division
Department of Infrastructure

Planning and Environment Act 1987
SOUTH GIPPSLAND PLANNING SCHEME
Notice of Approval of Amendment
Amendment C4

The Minister for Planning has approved Amendment C4 to the South Gippsland Planning Scheme.

The Amendment comes into operation on the date this notice is published in the Government Gazette.

The Amendment includes land adjacent to the South Gippsland Highway between Loch and Jeetho Road, in a Public Acquisition Overlay – PAO5, with VicRoads being the acquiring authority and the purpose of the acquisition being for the proposed improvement and deviation of the South Gippsland Highway.

A copy of the Amendment can be inspected, free of charge, during office hours, at the Department of Infrastructure, Planning Information Centre, Upper Plaza, Nauru House, 80 Collins Street, Melbourne and at the offices of the South Gippsland Shire Council, 9 Smith Street, Leongatha.

PAUL JEROME
Executive Director
Planning, Heritage and
Building Division
Department of Infrastructure

Planning and Environment Act 1987
YARRA PLANNING SCHEME
Notice of Approval of Amendment
Amendment C29

The Minister for Planning has approved Amendment C29 to the Yarra Planning Scheme.

The Amendment comes into operation on the date this notice is published in the Government Gazette.

The Amendment provides heritage controls for the Slade Knitwear sign at 105–115 Dover Street, Richmond and corrects the Heritage Overlay number on the Yarra Planning Scheme Maps for Darling Gardens to accord with the existing ordinance entry for this site.

A copy of the Amendment can be inspected, free of charge, during office hours, at the Department of Infrastructure, Planning

Information Centre, Upper Plaza, Nauru House,
80 Collins Street, Melbourne and at the offices
of the Yarra City Council, Richmond Town Hall,
333 Bridge Road, Richmond.

PAUL JEROME
Executive Director
Planning, Heritage and
Building Division
Department of Infrastructure

Planning and Environment Act 1987

BAW BAW PLANNING SCHEME

Notice of Lapsing of Amendment

Amendment C10 Part 2(ii)

The Baw Baw Shire Council has resolved to
abandon Amendment C10 Part 2(ii) to the Baw
Baw Planning Scheme.

The Amendment proposed the introduction
of a new local planning policy, 'Use of an
existing lot for a dwelling' at Clause 22.04-4
that would apply to the Rural Zone and
specifically to the consideration of applications
to use an existing lot for a dwelling.

The Amendment lapsed on 13 April 2002.

PAUL JEROME
Executive Director
Planning, Heritage and
Building Division
Department of Infrastructure

ORDERS IN COUNCIL

Cemeteries Act 1958

SCALE OF FEES

Order in Council

Under Section 17(1) of the **Cemeteries Act 1958**, and on the recommendation of the Minister for Health, the Governor-in-Council consents to the making of the Scales of Fees in respect of the following Public Cemetery Trusts:

Bellbrae
Edenhope
Cobram
Kaniva & Lillimur
Leongatha
Wodonga

Cemeteries Act 1958

SCALE OF FEES

By resolution of the Trust, the following fees will apply in the Bellbrae Public Cemetery from 16 April 2002, the date of approval by the Governor in Council.

All other fees are rescinded to the extent to which they conflict with this scale.

RIGHT OF BURIAL FEES:	\$
● Monumental Section	350.00
● Non-monumental Section	500.00
● Lawn Section	500.00
INTERMENT FEES:	
● Sinking or reopening	150.00
● Oversize casket – additional charge:	50.00
PERMIT TO INTER CREMATED REMAINS:	
● In private grave	70.00
● In Memorial Garden	120.00
PERMIT FEES FOR MONUMENTAL WORK:	
● To erect memorial or place bronze plaque (all sections):	60.00
● Additional inscription	20.00
Exhumation of the remains of a body	1,000.00

W. R. CUNNINGHAM (Chairman of Trustees)

J. F. BUFTON (Trustee)

G. H. O'BYRNE (Trustee and Hon. Treas.)

Cemeteries Act 1958**SCALE OF FEES**

By resolution of the Trust, the following fees will apply in the Edenhope Public Cemetery from the date of approval by the Governor in Council. All other fees are rescinded to the extent to which they conflict with this scale.

MONUMENTAL SECTION	\$
Land (2.4m x 1.22 m)	200.00
GRAVE DIGGING FEES	
1.83m (6')	300.00
2.13m (7')	340.00
Child under 12 years	100.00
INTERMENT FEES	
Normal Hours	200.00
Outside Normal Hours	300.00
RE-OPENING FEES	
No Cover	300.00
With Cover	320.00
Interment of Ashes in Private Grave	100.00
LAWN SECTION	
Land (2.4m x 1.22m)	500.00
GRAVE DIGGING FEES	
1.83m (6')	300.00
2.13m (7')	340.00
Child under 12 years	100.00
INTERMENT FEES	
Normal Hours	300.00
Outside Normal Hours	350.00
Re-opening Fees	250.00
Interment of Ashes in Private Grave	100.00
PLAQUE	
First interment (incl 5 lines inscription)	400.00
Second interment (2 further lines)	100.00
Any additional at Stonemasons cost	
NICHE WALL	
Memorial Wall Niche (incl 6 lines inscription)	200.00
Additional lines \$12.00 per line	
OTHER CHARGES	
Exhumation Fee	860.00
RECORDS SEARCH	
Simple Record Search	10.00
Detailed Record Search – Minimum Fee	25.00

MONUMENTAL WORKS

Permission to erect headstone or monument 10% of cost with
minimum of \$86.00

Notes:

1. This Scale of Fees shall be a minimum fees scale.
2. Monumental works, plaques and grave digging shall be charged at contractor's rates plus 10% administration charge where these rates exceed the minimum charges detailed.

BRUCE MEYER, trustee
GEOFFREY CARRACHER, trustee
LINDA GUTHRIDGE, trustee

Cemeteries Act 1958

SCALE OF FEES

By resolution of the Trust, the following fees will apply in the Cobram Public Cemetery from the date of approval by the Governor in Council. All other fees are rescinded to the extent to which they conflict with this scale.

MAUSOLEUM		\$
Section 1 & 2	Level D	19,360.00
Section 6	Level A & D	10,890.00
Veranda Doubles	Level A & D	14,520.00
	Level B & C	19,360.00
Veranda Singles	Level A & D	9,680.00
	Level B & C	12,100.00
Madonna	A	38,720.00
	B	48,400.00
Interment	\$550.00 plus hire of scissor lift where required	
MUSLIM SECTION		
Interment		425.00
Interment Saturday, Sunday & public holidays		502.00

MAX WOODS, trustee
FRANCESCO GALATI, trustee
HEATHER BURGESS, trustee

Cemeteries Act 1958

SCALE OF FEES

By resolution of the Trust, the following fees will apply in the Kaniva & Lillimur Public Cemetery from the date of approval by the Governor in Council. All other fees are rescinded to the extent to which they conflict with this scale.

MONUMENTAL SECTION	\$
Land (2.44m x 1.22m)	200.00

GRAVE DIGGING FEES	
1.83m (6')	300.00
2.13m (7')	340.00
Child under 12 years	100.00
INTERMENT FEES	
Normal Hours	200.00
Outside Normal Hours	300.00
RE-OPENING FEES	
No Cover	300.00
With Cover	320.00
Interment of Ashes in Private Grave	100.00
LAWN SECTION	
Land (2.4m x 1.22m)	500.00
GRAVE DIGGING FEES	
1.83m (6')	300.00
2.13m (7')	340.00
Child under 12 years	100.00
INTERMENT FEES	
Normal Hours	300.00
Outside Normal Hours	350.00
Re-opening Fees	250.00
Interment of Ashes in Private Grave	100.00
PLAQUE	
First interment (incl 5 lines inscription)	400.00
Second interment (2 further lines)	100.00
Any additional at Stonemasons cost	
NICHE WALL	
Memorial Wall Niche (incl 6 lines inscription)	200.00
Additional lines \$12.00 per line	
OTHER CHARGES	
Exhumation Fee	860.00
RECORDS SEARCH	
Simple Record Search	10.00
Detailed Record Search – Minimum Fee	25.00
MONUMENTAL WORKS	
Permission to erect headstone or monument	10% of cost with minimum of \$86.00

Notes:

1. This Scale of Fees shall be a minimum fees scale.
2. Monumental works, plaques and grave digging shall be charged at contractor's rates plus 10% administration charge where these rates exceed the minimum charges detailed.

BRUCE MEYER, trustee
 GEOFFREY CARRACHER, trustee
 LINDA GUTHRIDGE, trustee

Cemeteries Act 1958**SCALE OF FEES**

By resolution of the Trust, the following fees will apply in the Leongatha Public Cemetery from the date of approval by the Governor in Council. All other fees are rescinded to the extent to which they conflict with this scale.

	\$
New Lawn Grave	1,490.00
Re-open Lawn Grave	1,290.00
New Monumental Grave	1,240.00
Re-open Monumental Grave	1,050.00
Niche Wall	625.00
Children's Grave	800.00
Ashes Buried in Garden or under tree	750.00
All fees are inclusive of GST.	

ROBERT S. ATKIN, trustee
SHIRLEYANNE WRIGHT, trustee
GRAHAM T. FIXTER, trustee

Cemeteries Act 1958**SCALE OF FEES**

By resolution of the Trust, the following fees will apply in the Wodonga Public Cemetery from the date of approval by the Governor in Council. All other fees are rescinded to the extent to which they conflict with this scale.

	\$
LAWN AREA	
Land (2.44m x 1.22m)	
(two interments)	935.00
(three interments)	1,019.00
Re-opening a grave (2.13m)	982.00
Including interment fee	
Re-opening a grave (2.75m)	1,085.00
Including interment fee	
Re-opening a grave (2.75m)	869.00
Including (second interment fee)	
Interment on Saturday, Sunday or Public Holiday (extra)	179.00
CHILDREN'S LAWN SECTION	
Land for stillborn child	221.00
Land 2.44m x 1.22m (1.37m)	311.00
Land 1.22m x 1.22m (1.06m)	221.00
BABY AND STILLBORN COMMUNITY	
Land for baby or stillborn child	54.00
Sinking	Contract price plus 10%
MONUMENTAL SECTION	
Land 2.44m x 1.22m	
(two interments)	557.00

three interments	779.00
Land stillborn child	143.00
Re-opening grave (without headstone) including interment fee	629.00
Re-opening a grave (with headstone) at owners risk all inclusive	790.00
INTERMENT OF ASHES IN MEMORIAL GARDEN	
Plot	622.00
Plaques (if supplied by trust) (152mm x 152mm)	Contract price plus 10%
Affixing of plaque by caretaker	Contract price plus 10%
Casket (unusual size – extra)	72.00
Vase (if supplied by trust)	Contract price plus 10%
Interment of ashes in private grave	156.00
Exhumation charge (when authorised)	1,559.00
Search records and providing written information	30.00
Interment of ashes under selected rock (Lower Section)	959.00
Selected rock (Top Section)	2,038.00
Interment of ashes in flagpole garden	935.00
SINKING FEE	
Sinking grave to 2.13m	Contract price plus 10%
Sinking grave to 1.37m	Contract price plus 10%
Sinking grave to 2.75m (9')	Contract price plus 10%
DESKS	
Desk	50.00
Single plaque (if supplied by trust) (381mm x 279mm)	Contract price plus 10%
Double plaque (if supplied by trust) (381mm x 279mm)	Contract price plus 10%
Interment fee (Adult)	126.00
Interment fee (Children)	77.00
ALL PRICES ARE GST INCLUSIVE	

GRAHAM CHARLES GEHRIG, trustee
 LESLIE CHARLES BOYES, trustee
 MARGARET RUTH ANDREWS, trustee
 BRUCE WILFRED POOLEY, trustee
 ALLEN WILLIAM CUMMING, trustee

Dated 16 April 2002
 Responsible Minister:
 Hon JOHN THWAITES MP
 Minister for Health

HELEN DOYE
 Clerk of the Executive Council

Cemeteries Act 1958

SCALE OF FEES

Order in Council

Under Section 17(1) of the **Cemeteries Act 1958**, and on the recommendation of the Minister for Health, the Governor-in-Council consents to the making of the Scales of Fees in respect of the following Public Cemetery Trusts:

Anderson's Creek
 Bairnsdale
 Bonnie Doon
 Box Hill
 Jamieson
 Lorne
 Mansfield
 Merton
 Mount Moriac
 Nyora
 Quambatook
 Seymour
 Wangaratta
 Winchelsea
 Wychitella

Cemeteries Act 1958

SCALE OF FEES

By resolution of the Trust, the following fees will apply in the Anderson's Creek Cemetery from the date of approval by the Governor in Council. All other fees are rescinded to the extent to which they conflict with this scale.

CREMATED REMAINS	\$
The Bence Rock Section, single plot	1,870.00

JOHN CHAPMAN, trustee
 TERRY SLOAN, trustee
 ROBERT WHITE, trustee

Cemeteries Act 1958

SCALE OF FEES

By resolution of the Trust, the following fees will apply in the Bairnsdale Public Cemetery from the date of approval by the Governor in Council. All other fees are rescinded to the extent to which they conflict with this scale.

Children's Lawn – length 1.4m – site, digging	\$ 513.00
Memorial Garden – Site, interment of ashes	308.00

Opening and re-sealing of concrete-lined grave	603.00
Plaques/Vases/Beams – at cost plus 25%	

DARREN GOODMAN, trustee
TIM GIBSON, trustee
MARGARET HANNINGTON, trustee

Cemeteries Act 1958

SCALE OF FEES

By resolution of the Trust, the following fees will apply in the Mansfield, Bonnie Doon, Merton and Jamieson Public Cemeteries from the date of approval by the Governor in Council. All other fees are rescinded to the extent to which they conflict with this scale.

	\$
MONUMENTAL SECTION	
Land 2.4 x 1.2 selected by trustees	300.00
Land 2.4 x 1.2 selected by applicant	330.00
Land 1.2 x 1.2 (child up to 12 years)	300.00
Sinking to 2.1 metres	800.00
Sinking to 1.2 metres (children's section)	300.00
Re-open for second burial	495.00
Interment fee	75.00
LAWN SECTION	
Land 2.4 x 1.2 (including mounting base and flower container)	560.00
Re-open for second burial	495.00
Sinking to 2.1 metres	800.00
Plaque & flower container	410.00
Interment fee	75.00
MISCELLANEOUS CHARGES	
Ashes in Niche Wall	195.00
Plaque for Niche Wall	190.00
Plaque & Concrete block in Monumental Section	410.00
Additional fee for weekends or public holidays	120.00
Additional sinking oversize grave (per 300mm/foot)	90.00
Interment of Ashes in Grave (per cannister)	240.00
Interment of Ashes at base of Memorial Tree (per cannister)	270.00
Removal of Ashes–Niche Wall (when authorised/per grave)	550.00
Memorial trees by agreement (per tree)	190.00
Memorial shrubs by agreement (per shrub)	150.00
Plaque for trees and shrubs	190.00
Fee to erect monument or plaque in Monumental Section 5% of value of work or base rate	80.00
Reinstatement/Restoration works in Monumental Section	Cost +10%
Fee for search of records	20.00
Fee to erect Australian War Graves Plaque	200.00

Cancellation of order to sink if commenced	100.00
Certificate of right of burial issue	30.00
	D. CUMMINS, (Mayor)
	W. TWYCROSS, (Councillor)
	S. JUNCHENN, (Councillor)

Cemeteries Act 1958

SCALE OF FEES

By resolution of the Trust, the following fees will apply in the Box Hill Public Cemetery from the date of approval by the Governor in Council. All other fees are rescinded to the extent to which they conflict with this scale.

LAND FOR PRIVATE GRAVES	\$
Earth grave (2.44m x 1.22m)	1,110.00
Lined grave	5,775.00
Ashes in Lawn (plot)	370.00
INTERMENT IN PRIVATE GRAVES	
Sinking earth grave (standard width at shoulder 0.68m)	860.00
Re-open earth grave (without slab or cover)	860.00
Re-open earth grave (with slab or cover)	1,045.00
Lined grave	860.00
Ashes in earth grave (earth top)	245.00
Ashes in earth grave (pebble top)	335.00
Ashes in earth grave (with slab)	430.00
Ashes in Columbarium	245.00
Interment in a Mausoleum crypt space	860.00
NICHES FOR CREMATED REMAINS	
Pavilion Arch	
Wall niche – (single)	125.00
EXTRA CHARGES	
Sinking grave over standard width (0.68m at shoulder)	185.00
Sinking grave for square casket	185.00
Interment not in usual hours i.e. before 9.00 a.m. or after 4.00 p.m. (excluding Saturday, Sunday or Public Holiday)	185.00
Interment on Saturday, Sunday or Public Holiday (where permitted)	430.00
Removal of screenings on grave	90.00
Removal and Replacement of slab	185.00
NOTE:– Where the removal and replacement of a slab is not performed by the Cemetery employees, arrangements must be made by the holder of the Right of Burial, prior to the opening of the grave for such removal and replacement at the expense of the holder.	
PLAQUE CHARGES	
Bronze plaque – 7 ¹ / ₂ ” x 4 ¹ / ₂ ”	260.00
Single wall niche (ten line inscription) – 7” x 7”	300.00
Ashes in Lawn (six line inscription) – 9” x 9”	345.00

Lawn grave – Dual + Detachable plate – 15” x 11” (Four line plate)	430.00
Second Detachable Plate – (Four lines)	125.00
MISCELLANEOUS CHARGES	
Deposit for Casket Space (Community Mausoleum)	6,000.00
Exhumation of body (when authorised)	1,965.00
Exhumation of Ashes	190.00
Vase for Lawn plaques (optional)	85.00
Granite Base – (15” x 11” plaque) etc.	300.00
Administration Fee – Renewal of un-used grave after 25 years tenure	300.00
Administration Fee – Cancellation of mausoleum crypt space	300.00
GRAVE MAINTENANCE CHARGES (OPTIONAL)	
Earth grave only – per annum	70.00
MONUMENTAL FEES	
Monumental work – Current cemetery fee is 12% of contract price of monument. GST inclusive of contract price of the monument.	
Added inscription	70.00
COMMUNITY MAUSOLEUM – STAGE 1	

North and South Colonnades

True Companion (2 spaces) \$	Pairs (2 spaces) \$	Single (1 space) \$
E 14,000.00	22,000.00	12,000.00
D 18,000.00	28,000.00	15,000.00
C 26,000.00	35,000.00	18,000.00
B 28,000.00	37,000.00	20,000.00
A 22,000.00	30,000.00	16,000.00

East Colonnade

Pairs (2 spaces) \$	Single (1 space) \$
E 24,000.00	13,000.00
D 30,000.00	17,000.00
C 38,000.00	21,000.00
B 40,000.00	22,000.00
A 33,000.00	18,000.00

Notes – Re Mausoleum Complex

1. All fees include GST.
2. All fees include memorialisation including: lamp/vase fitting, colour ceramic photographs and cast bronze lettering or plaques.

ERIC L. COLLYER, trustee
JEANNE E. WHITNEY, trustee
VICKI A. GOODALL, trustee

Cemeteries Act 1958

SCALE OF FEES

By resolution of the Trust, the following fees will apply in the Lorne Public Cemetery from the date of approval by the Governor in Council. All other fees are rescinded to the extent to which they conflict with this scale.

All prices inclusive of GST.

Area	Proposed Fees Lorne Cemetery \$
Land Lawn Section	550.00
Land Monumental Section	750.00
Interment Fee	350.00
Exhumation Fee	1,000.00
Headstone Erection	7% of cost (min. \$100.00)
COLUMBARIUM WALL	
Row A (top)	385.00
Row B	357.50
Row C	330.00
Row D	302.50
Row E	275.00
Row F (bottom)	247.50

NELSON ENGLISH, trustee

SUSAN RECHENBERG-DUPE, trustee

L.A. SCHROETER, trustee

Cemeteries Act 1958

SCALE OF FEES

By resolution of the Trust, the following fees will apply in the Mount Moriac Public Cemetery from the date of approval by the Governor in Council. All other fees are rescinded to the extent to which they conflict with this scale.

All prices inclusive of GST.

Area	Proposed Fees Mount Moriac Cemetery \$
Land Lawn Section	550.00
Land Monumental Section	750.00
Interment Fee	350.00
Exhumation Fee	1,000.00
Headstone Erection	7% of cost (min. \$100.00)
COLUMBARIUM WALL	
Row A (top)	385.00
Row B	357.50

Row C	330.00
Row D	302.50
Row E	275.00
Row F (bottom)	247.50

NELSON ENGLISH, trustee
L.A. SCHROETER, trustee
SUSAN RECHENBERG-DUPE, trustee

Cemeteries Act 1958

SCALE OF FEES

By resolution of the Trust, the following fees will apply in the Nyora Public Cemetery from the date of approval by the Governor in Council. All other fees are rescinded to the extent to which they conflict with this scale.

	\$
New Grave	600.00
Re-opening	575.00

JAN JOHAN VAN DOORN, trustee
JOHN BERTRAM HALLAS, trustee
BRIAN JAMES WALTERS, trustee

Cemeteries Act 1958

SCALE OF FEES

By resolution of the Trust, the following fees will apply in the Quambatook Public Cemetery from the date of approval by the Governor in Council. All other fees are rescinded to the extent to which they conflict with this scale.

MONUMENTAL SECTION

PUBLIC GRAVES	\$
Interment in grave without exclusive right – stillborn	150.00
Interment in grave without exclusive right – others	200.00
Number peg	20.00
PRIVATE GRAVES	
Plot 2.44m x 1.22m	150.00
SINKING CHARGES FOR PRIVATE GRAVES	
Sinking grave 1.83m deep	200.00
Sinking oversize grave (extra)	40.00
RE-OPENING CHARGES	
Re-opening grave (no cover)	200.00
Re-opening grave (with cover)	220.00
MISCELLANEOUS CHARGES	
Number peg	20.00

Permission to erect a headstone or monument	10% of cost with a minimum of \$10.00
Permission to construct a brick grave or to erect any stone, kerb, brick tile work or concrete	25.00
Exhuming the remains of a body (when authorised)	860.00
Interment of ashes in private grave	100.00
LAWN SECTION (NON-DENOMINATIONAL)	
Sinking grave 1.83m deep	200.00
Sinking oversize grave (extra)	40.00
Plot 2.44 m x 1.22 m	400.00
For each interment there in	300.00
Exhuming remains of body (when authorized)	860.00
Ashes buried in existing lawn grave	100.00
Lawn grave for child five years and under	300.00
Flower Container	25.00
Bronze Plaque 56 cm x 30 cm Dual	Contract price plus 10%
Bronze Plaque 56 cm x 30 cm Single	Contract price plus 10%
Small Plaque for second interment	Contract price plus 10%
ROSE GARDEN	
Interment of ashes	100.00
Base and mounting	100.00
Plaque	Contract price plus 10%

Clients have a right to order plaques elsewhere

MAX CAMERON, trustee
L. P. NOLAN, trustee
LEO H. PARKER, trustee

Cemeteries Act 1958

SCALE OF FEES

By resolution of the Trust, the following fees will apply in the Seymour Public Cemetery from the date of approval by the Governor in Council. All other fees are rescinded to the extent to which they conflict with this scale.

MONUMENTAL SECTION	(Inclusive of GST)
	\$
Land 2.44m x 1.2m	495.00
Own selection of land (extra)	70.00
LAWN SECTION	
Land 2.44m x 1.22m	770.00
Bronze plaque available	Cost price + 15%
SINKING CHARGES	
Sinking grave 2.13m deep (7 feet)	330.00
Sinking grave 2.75m deep (9 feet)	395.00

Re-opening grave 1.55m deep (5 feet)	265.00
Re-opening grave 2.13m deep (7 feet)	330.00
Sinking oversize grave or for American type casket (extra)	120.00
MISCELLANEOUS CHARGES	
Interment fee	165.00
Exhumation fee (when authorised)	860.00
Cancellation of order (if commenced)	85.00
Permission to erect a headstone or monument –	10% of cost with a minimum of \$120.00
Permission to erect a brick grave or to erect any stone kerb, brick or tile work	65.00
Interment of ashes in private grave	80.00
Certificate of right of burial	25.00
Inspection of plan or register	17.00
Detachable plate with 5 lines	85.00
Rose shrub	200.00
Bronze plaque for rose garden	160.00
Cement block for plaque (includes affixing)	33.00
Plaque for Niche Wall (includes affixing)	240.00
Inter ashes in Niche Wall	200.00

MADELINE M. BYRNE, trustee
 STANLEY JOHN WAITE, trustee
 GERARD VINCENT O'ROURKE, trustee

Cemeteries Act 1958

SCALE OF FEES

By resolution of the Trust, the following fees will apply in the Wangaratta Public Cemetery from the date of approval by the Governor in Council. All other fees are rescinded to the extent to which they conflict with this scale.

	Inc GST
GRAVESITE:	\$
General and Lawn	660.00
Children (under 12 months)	110.00
Oversize Grave (new fee)	55.00
INTERMENT FEE:	
1st & 2nd interments	550.00
Children	330.00
Vault	660.00
Extra charge – Saturday or P/Holiday	440.00
LAWN PLAQUES (including installations):	
Single 380 x 280mm	Cost + 30% admin. & handling fee
Dual	Cost + 30% admin. & handling fee
Dual – detachable plant	Cost + 30% admin. & handling fee
INTERMENT OF ASHES:	
Niche Wall	450.00

Rose Garden	500.00
Shrub or Tree	660.00
Private Gravesite	165.00
Memorial Plaque	Cost + 30% admin. & handling fee
DISPOSAL OF ASHES OTHER THAN INTERMENT:	77.00
PERMISSION TO ERECT A HEADSTONE OR MONUMENT	
General 10% of cost	165.00
Lawn – excluding flower containers	110.00
Children’s Lawn – excluding flower containers	66.00
Second inscription	82.00
MISCELLANEOUS	
Search Fee	44.00
Removal of Cover (at Owners Risk)	82.00
Exhumation Fee	1,045.00
Use of Canopy and Chairs (new fee)	27.00

GEOFFREY NELSON DINNING, trustee
 ANTHONY DAVID GRIFFITHS, trustee
 KEIRAN ANTHONY KLEMM, trustee

Cemeteries Act 1958

SCALE OF FEES

By resolution of the Trust, the following fees will apply in the Winchelsea Public Cemetery from the date of approval by the Governor in Council. All other fees are rescinded to the extent to which they conflict with this scale.

All prices inclusive of GST.

Area	Proposed Fees Winchelsea Cemetery \$
Land Lawn Section	550.00
Land Monumental Section	750.00
Interment Fee	350.00
Exhumation Fee	1,000.00
Headstone Erection	7% of cost (min. \$100.00)
COLUMBARIUM WALL	
Row A (top)	385.00
Row B	357.50
Row C	330.00
Row D	302.50
Row E	275.00
Row F (bottom)	247.50

L.A. SCHROETER, trustee
 NELSON ENGLISH, trustee
 SUSAN RECHENBERG-DUPE, trustee

Cemeteries Act 1958

SCALE OF FEES

By resolution of the Trust, the following fees will apply in the Wychitella Public Cemetery from the date of approval by the Governor in Council. All other fees are rescinded to the extent to which they conflict with this scale.

	\$
Reserve grave site	55.00
Selection own site	30.00
Grave site – Single	220.00
– Double	250.00
– Oversize	260.00
Re-opening	220.00
Re-opening with cover	230.00
Interment Fee	35.00
Number Peg	12.00
Exhumation Fee	860.00

BARRY JAMES, trustee
COLIN J. COGHILL, trustee
ALBERT E. CHALMERS, trustee

Dated 16 April 2002
Responsible Minister:
Hon JOHN THWAITES MP
Minister for Health

HELEN DOYE
Clerk of the Executive Council

Local Government Act 1989

BRIMBANK CITY COUNCIL

Specification of Dates

Order in Council

The Governor in Council under Sections 3, 21, 21A and 22 of the **Local Government Act 1989**
ORDERS THAT:

the dates for Brimbank City Council's Padley Ward by-election to be held on 20 July 2002 shall be:

Monday 13 May 2002 Entitlement date for the purposes of Division 1 of Part 3 of the **Local Government Act 1989**;

Tuesday 21 May 2002 The date by which the Electoral Commissioner must supply to the Chief Executive Officer a voters' list for the purposes of section 21(2) of the **Local Government Act 1989**;

Friday 31 May 2002 The date by which the Chief Executive Officer must make out a voters' list for the purposes of sections 22(2) and 22(2A) of the **Local Government Act 1989**.

Dated 7 May 2002
Responsible Minister
BOB CAMERON MP
Minister for Local Government

HELEN DOYE
Clerk of the Executive Council

Land Act 1958

APPROVAL BY THE GOVERNOR IN
COUNCIL TO THE SALE OF CROWN
LAND BY PRIVATE TREATY

Order in Council

The Governor in Council, pursuant to sections 99A(1)(a) & 99A(2) of the **Land Act 1958**, approves the sale by private treaty of Crown Allotment 87B, Parish of Neerim and located at Addison Street, Neerim South.

Dated 7 May 2002

Responsible Minister:
JOHN LENDERS MP
Minister for Finance

HELEN DOYE
Clerk of the Executive Council

Crown Land (Reserves) Act 1978

NOTICE OF INTENTION TO REVOKE
TEMPORARY RESERVATION

The Governor in Council under section 10 of the **Crown Land (Reserves) Act 1978** gives notice of intention to revoke the following temporary reservation:

LAKE BOGA — The temporary reservation by Order in Council of 20 July, 1925 of an area of 1.153 hectares of land in the Township of Lake Boga, Parish of Kunat Kunat as a site for a Tree Plantation, revoked as to part by Orders in Council of 29 March, 1983 and 2 July, 1996 so far as the balance remaining containing 4556 square metres, more or less. — (Rs 6249).

This Order is effective from the date on which it is published in the Government Gazette.

Dated 7 May 2002

Responsible Minister
SHERRYL GARBUTT
Minister for Environment
and Conservation

HELEN DOYE
Clerk of the Executive Council

Crown Land (Reserves) Act 1978

REVOCATION OF TEMPORARY
RESERVATION

The Governor in Council under section 10 of the **Crown Land (Reserves) Act 1978** revokes the following temporary reservation:

WODONGA — The temporary reservation by Order in Council of 23 March, 1911 of an area of 3.195 hectares of land being Crown Allotment 17, Section 1A, Parish of Wodonga as a site for supply of gravel. — (Rs 7557).

This Order is effective from the date on which it is published in the Government Gazette.

Dated 7 May 2002

Responsible Minister
SHERRYL GARBUTT
Minister for Environment
and Conservation

HELEN DOYE
Clerk of the Executive Council

Crown Land (Reserves) Act 1978

REVOCATION OF TEMPORARY
RESERVATION

The Governor in Council under section 10 of the **Crown Land (Reserves) Act 1978** revokes the following temporary reservation:

MURRAYVILLE — The temporary reservation by Order in Council of 24 August, 1914 of an area of 8.169 hectares of land being Crown Allotment 17, Section 23, Township of Murrayville, Parish of Danyo as a site for Sanitary Depot. — (Rs 00005).

This Order is effective from the date on which it is published in the Government Gazette.

Dated 7 May 2002

Responsible Minister
SHERRYL GARBUTT
Minister for Environment
and Conservation

HELEN DOYE
Clerk of the Executive Council

Crown Land (Reserves) Act 1978

TEMPORARY RESERVATION OF
CROWN LANDS

The Governor in Council under section 4(1) of the **Crown Land (Reserves) Act 1978** temporarily reserves the following Crown lands which in his opinion are required for the purposes mentioned :-

MUNICIPAL DISTRICT OF THE
GREATER GEELONG CITY COUNCIL
BELLARINE — Public purposes (Police purposes), 1698 square metres, being Crown Allotment 2001, Parish of Bellarine as indicated by hatching on plan hereunder. (GP967) — (07/2011931).

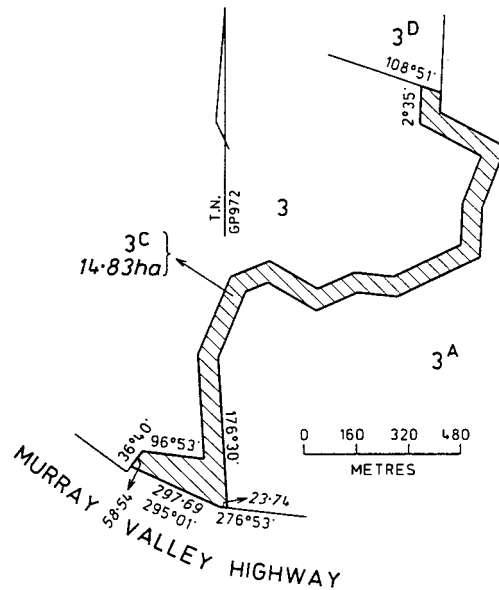
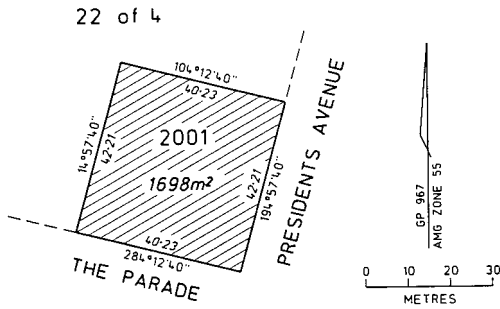

MUNICIPAL DISTRICT OF THE
SOUTHERN GRAMPIANS SHIRE COUNCIL
MONIVAE — Pastoral Research Station, 53.50 hectares, more or less, being Crown Allotment 2001, Parish of Monivae as indicated by hatching on plan hereunder. (GP960) — (Rs 8103).

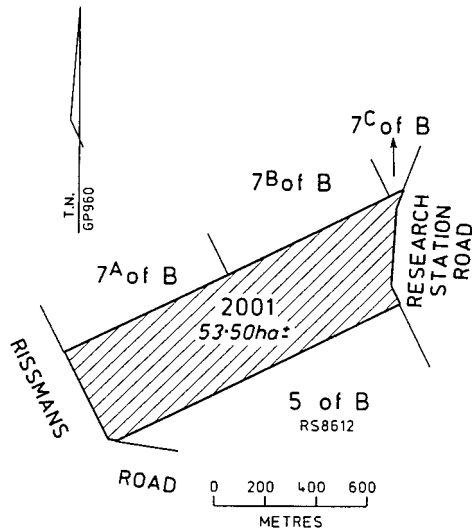

MUNICIPAL DISTRICT OF THE HORSHAM
RURAL CITY COUNCIL
TELANGATUK — Management of wildlife and preservation of wildlife habitat, 452 hectares, more or less, being Crown Allotment 74B, Parish of Telangatuk as indicated by hatching on plan hereunder. (GP976) — (2011801).

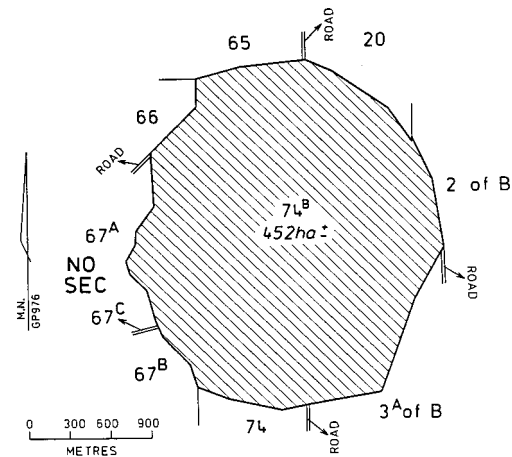

MUNICIPAL DISTRICT OF THE
SWAN HILL RURAL CITY COUNCIL
NENANDIE — Management of wildlife and preservation of wildlife habitat, 14.83 hectares, being Crown Allotment 3C, Parish of Nenandie as indicated by hatching on plan hereunder. (GP972) — (0104912).

MUNICIPAL DISTRICT OF THE
SHIRE OF YARRA RANGES
WANDIN YALLOCK — Public purposes (Police purposes), 360 square metres, being Crown Allotment 141E, Parish of Wandin Yallock as indicated by hatching on plan hereunder. (GP957) — (Rs 7475).

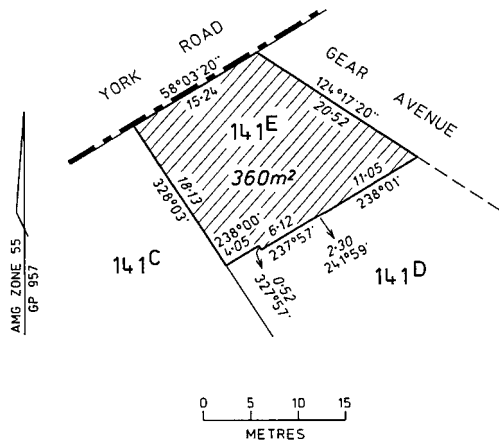

MUNICIPAL DISTRICT OF THE MORNINGTON PENINSULA SHIRE COUNCIL

WANNAEUE — Public Purposes, 1.85 hectares, more or less, being Crown Allotment 53A, Section A, Parish of Wannaeue as indicated by hatching on plan hereunder. (GP974) — (Rs 37260).

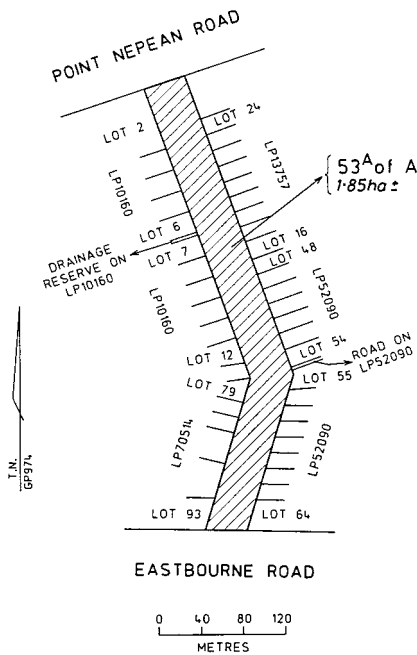

MUNICIPAL DISTRICT OF THE WELLINGTON SHIRE COUNCIL

YARRAM YARRAM — Public purposes, total area 7.78 hectares, more or less, being Crown Allotments 2001, 2002 and 2003, Parish of Yarram Yarram as shown by red outline on Plan

LEGL./01-123 lodged in the Central Plan Office. — (2011718).

MUNICIPAL DISTRICT OF THE SHIRE OF YARRA RANGES

YERING — Conservation of an area of natural interest, 7.214 hectares, being Crown Allotment 2002, Parish of Yering as indicated by hatching on plan hereunder. (GP956) — (Rs 37262).

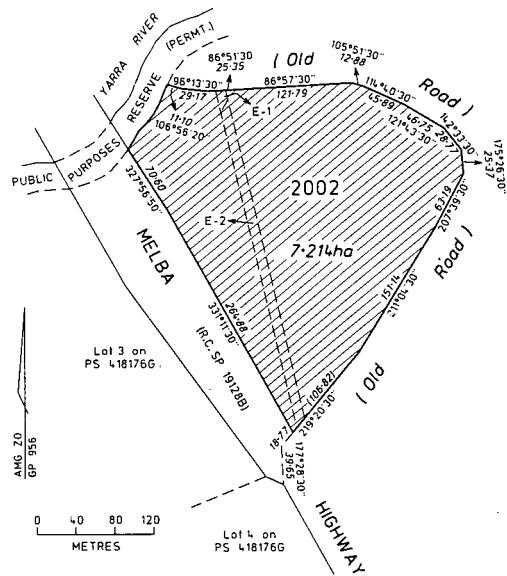

E-1 ELECTRICITY TRANSMISSION EASEMENT VIDE INST.1550247
E-2 ELECTRICITY TRANSMISSION EASEMENT VIDE INST.1550497

This Order is effective from the date on which it is published in the Government Gazette.

Dated 7 May 2002

Responsible Minister
SHERRYL GARBUTT
Minister for Environment
and Conservation

HELEN DOYE
Clerk of the Executive Council

Crown Land (Reserves) Act 1978
Interpretation of Legislation Act 1984
AMENDMENT OF TEMPORARY RESERVATION

The Governor in Council under Section 4 of the **Crown Land (Reserves) Act 1978** and Section 27 of the **Interpretation of Legislation Act 1984** amends the Order in Council made on

24 July, 1979 and published in the Government Gazette on 1 August, 1979 page 2439 of the temporary reservation of Crown Allotment 48, Section 2, Township of Mirboo North, Parish of Mirboo, County of Buln Buln as a site for Water Supply purposes by deletion of the words "Site for Water Supply purposes" and the substitution thereof of the words "Public Purposes". — Rs 10729.

This Order is effective from the date on which it is published in the Government Gazette Dated 7 May 2002

Responsible Minister
SHERRYL GARBUTT
Minister for Environment
and Conservation

HELEN DOYE
Clerk of the Executive Council

Land Act 1958

CLOSURE OF UNUSED ROAD

The Governor in Council under section 349 of the **Land Act 1958** and with the concurrence in writing of the municipality in which the road is situated closes the following unused road:

MUNICIPAL DISTRICT OF THE NORTHERN GRAMPIANS SHIRE COUNCIL

STAWELL — The road in the Township of Stawell, Parish of Stawell shown as Crown Allotment 2004 on Original Plan No. 121686 lodged in the Central Plan Office. — (DTF/97/05676).

This Order is effective from the date on which it is published in the Government Gazette.

Dated 7 May 2002

Responsible Minister
SHERRYL GARBUTT
Minister for Environment
and Conservation

HELEN DOYE
Clerk of the Executive Council

Land Act 1958

CLOSURE OF UNUSED ROADS

The Governor in Council under section 349 of the **Land Act 1958** and with the concurrence in writing of the municipalities in which the roads are situated and the owners of land adjoining those roads closes the following unused roads:

MUNICIPAL DISTRICT OF THE PYRENEES SHIRE COUNCIL

MORTCHUP — The road in the Parish of Mortchup being Crown Allotment 2002 as indicated by hatching on plan hereunder. (GP949) — (053633).

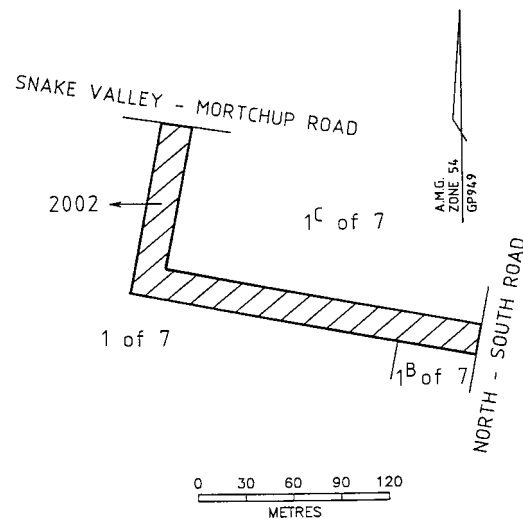

MUNICIPAL DISTRICT OF THE GOLDEN PLAINS SHIRE COUNCIL

MURGHEBOLUC — The road in the Parish of Murgheboluc shown as Crown Allotment 2001, No Section on Original Plan No. 121661 lodged in the Central Plan Office. — (07/L1-4806).

MUNICIPAL DISTRICT OF THE MORNINGTON PENINSULA SHIRE COUNCIL

WANNAEUE — The road in the Parish of Wannaeue shown as Crown Allotment 2004 on Original Plan No. 121705 lodged in the Central Plan Office. — (12/L12-1372).

MUNICIPAL DISTRICT OF THE
SHIRE OF MURRINDINDI

WHENREGARWEN - The road in the Parish of Whenregarwen being Crown Allotment 2002 as indicated by hatching on plan hereunder. (GP925) — (09/P181919).

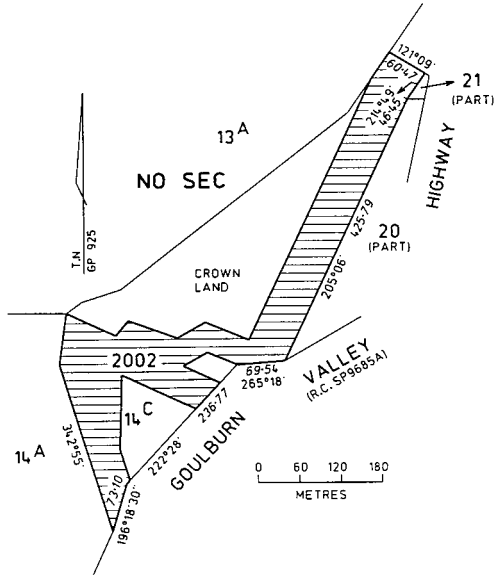

This Order is effective from the date on which it is published in the Government Gazette.

Dated 7 May 2002

Responsible Minister
SHERRYL GARBUTT
Minister for Environment
and Conservation

HELEN DOYE
Clerk of the Executive Council

VICTORIA

State Aid to Religion Abolition Act 1871

ACT NO. 391/1871 — SECOND SCHEDULE

A statement of trusts having been submitted by the head or authorised representative of the Uniting Church in Australia under the provisions of the “Act to provide for the abolition of State Aid to Religion” for allowance by the Governor in Council, the same was allowed by him on the Seventh day of May, 2002 and the following is the form in which such statement of trusts has been allowed.

STATEMENT OF TRUSTS

DESCRIPTION OF LAND —

Site for Primitive Methodist Place of Public Worship temporarily reserved by Order in Council of 3 August, 1868 being 4047 square metres, Parish of Bulban, County of Grant being Crown Allotment 4B.

Commencing at the junction of Boadles Land and Edgars Road; bounded thence by Edgars Road bearing 0° 18' 80.67 metres; thence by allotment 4A bearing 90° 00' 50.29 metres; thence by the site reserved for Water Supply purposes by Order in Council of 2 June, 1970 bearing 180° 18' 80.27 metres, and thence by Boadles Lane bearing 269° 45' 50.29 metres to the point of commencement.

NAME OF TRUSTEES

The Uniting Church in Australia Property Trust (Victoria).

POWERS OF DISPOSITION

Such powers of disposition including powers of sale, lease or mortgage as are given to the Trustee by the **Uniting Church in Australia Act No. 9021 of 1977** as amended.

PURPOSES TOWARDS WHICH PROCEEDS OF DISPOSITION ARE TO BE APPLIED —

To such Uniting Church in Australia purposes as shall be approved by the Synod of Victoria of the Uniting Church in Australia.

This Order is effective from the date on which it is published in the Government Gazette.

Dated 7 May 2002

Responsible Minister
SHERRYL GARBUTT
Minister for Environment
and Conservation

HELEN DOYE
Clerk of the Executive Council

VICTORIA

State Aid to Religion Abolition Act 1871

ACT NO. 391/1871 — SECOND SCHEDULE

A statement of trusts having been submitted by the head or authorised representative of the Uniting Church in Australia under the provisions of the “Act to provide for the abolition of State Aid to Religion” for allowance by the Governor in Council, the same was allowed by him on the Seventh day of May, 2002 and the following is the form in which such statement of trusts has been allowed.

STATEMENT OF TRUSTS

DESCRIPTION OF LAND —

Site for Free Presbyterian Church purposes temporarily reserved by Order in Council of 10 June, 1861 being 8098 square metres, Parish of Conewarre, County of Grant being Crown Allotment B6, Section 21.

Commencing at the south-western angle of the site being a point bearing 68° 30' 20.12 metres from the south-eastern angle of allotment G, section 20; bounded thence by a road bearing 338° 30' 60.35 metres; thence by allotment B5, section 21 and a road bearing 68° 30' 134.18 metres; and thence by roads bearing 158° 30' 60.35 metres and bearing 248° 30' 134.18 metres to the point of commencement.

NAME OF TRUSTEES

The Uniting Church in Australia Property Trust (Victoria).

POWERS OF DISPOSITION

Such powers of disposition including powers of sale, lease or mortgage as are given to the Trustee by the **Uniting Church in Australia Act No. 9021 of 1977** as amended.

PURPOSES TOWARDS WHICH PROCEEDS OF DISPOSITION ARE TO BE APPLIED —

To such Uniting Church in Australia purposes as shall be approved by the Synod of Victoria of the Uniting Church in Australia.

This Order is effective from the date on which it is published in the Government Gazette.

Dated 7 May 2002

Responsible Minister
SHERRYL GARBUTT
Minister for Environment
and Conservation

HELEN DOYE

Clerk of the Executive Council

VICTORIA

State Aid To Religion Abolition Act 1871

ACT NO. 391/1871 — SECOND SCHEDULE

A statement of trusts having been submitted by the head or authorised representative of the Uniting Church in Australia under the provisions of the "Act to provide for the abolition of State Aid to Religion" for allowance by the Governor in Council, the same was allowed by him on the Seventh day of May, 2002 and the following is the form in which such statement of trusts has been allowed.

STATEMENT OF TRUSTS

DESCRIPTION OF LAND —

Site for Wesleyan Church purposes temporarily reserved by Order in Council of 7 January, 1861 and Wesleyan Place of Public Worship temporarily reserved by Order in Council of 8 May, 1871.

2023 square metres, Township of Heywood, Parish of Heywood, being Crown Allotment 1, Section 2.

Commencing at the south-eastern angle allotment 3, section 2, bounded thence by that allotment bearing 0° 00' 50.29 metres; thence by a line bearing 90° 00' 40.23 metres; thence by Fitzroy Street bearing 180° 00' 50.29 metres, and thence by Hunter Street bearing 270° 00' 40.23 metres to the point of commencement.

2023 square metres, Township of Heywood, Parish of Heywood, being Crown Allotment 2, Section 2.

Commencing at the north-eastern angle allotment 3, section 2, bounded thence by Cameron Street bearing 90° 00' 40.23 metres; thence by Fitzroy Street bearing 180° 00' 50.29 metres, thence by a line bearing 270° 00' 40.23 metres and thence by allotment 3, section 2 bearing 0° 00' 50.29 metres to the point of commencement.

NAME OF TRUSTEES

The Uniting Church in Australia Property Trust (Victoria).

POWERS OF DISPOSITION

Such powers of disposition including powers of sale, lease or mortgage as are given to the Trustee by the **Uniting Church in Australia Act No. 9021 of 1977** as amended.

PURPOSES TOWARDS WHICH PROCEEDS OF DISPOSITION ARE TO BE APPLIED —

To such Uniting Church in Australia purposes as shall be approved by the Synod of Victoria of the Uniting Church in Australia.

This Order is effective from the date on which it is published in the Government Gazette.

Dated 7 May 2002

Responsible Minister
SHERRYL GARBUTT
Minister for Environment
and Conservation

HELEN DOYE

Clerk of the Executive Council

Crown Land (Reserves) Act 1978**INCORPORATION OF COMMITTEES OF MANAGEMENT AND APPOINTMENT OF CHAIRPERSONS**

The Governor in Council under section 14A(1) of the **Crown Land (Reserves) Act 1978**, being satisfied that it is in the public interest to declare to be corporations the Committees of Management appointed under section 14(2) of the Act of the lands described in Column 1 of the schedule hereunder :-

- (a) declares that the Committees of Management shall be corporations;
- (b) assigns the names shown in Column 2 to the corporations; and
- under section 14B(3) of the Act, appoints the persons listed in Column 3 to be Chairpersons of the corporations.

SCHEDULE

Column 1 Reserve details	Column 2 Corporate name	Column 3 Chairperson
Wodonga Racecourse, Recreation and Show Ground Reserve — The remaining land in the Parish of Wodonga temporarily reserved for Racecourse and Public Recreation Ground by Orders in Council of 17 April, 1871, 7 January, 1930 and for the additional purpose of Show Ground by Order in Council of 16 November, 1948 [Rs 01734].	Wodonga Racecourse Recreation Reserve Committee of Management Incorporated	Raymond Ignatius O'TOOLE
Springhurst Recreation and Public Hall Reserves — The remaining land in the Township of Springhurst temporarily reserved for Public Recreation by Order in Council of 9 December, 1885 and for the additional purpose of Public Hall by Order in Council of 13 September, 1983 as well as the land temporarily reserved for Public Hall by Order in Council of 10 April, 1979, [Rs 610].	Springhurst Recreation and Community Hall Reserves Incorporated	Kevin ATTERIDGE
Woolsthorpe Mechanics' Institute and Free Library Reserve — The land in the Township of Woolsthorpe temporarily reserved for Mechanics' Institute and Free Library by Order in Council of 26 November, 1888 (vide Government Gazette of 30 November, 1888 – page 3600) [Rs 4638].	Woolsthorpe Hall Committee Incorporated	Joan HIRST
Baring Recreation Reserve — The lands in the Parish of Baring temporarily reserved for Public Purposes and Recreation by Orders in Council of 14 September, 1936, 13 March, 1968, 28 October, 1969 and 23 September, 1986 [Rs 4613].	Baring Recreation Reserve Committee of Management Incorporated	Simon GRIGG

Column 1 Reserve details	Column 2 Corporate name	Column 3 Chairperson
<p>Pax Hill Scout Camp Reserve — The lands in the Township of Ballarat East temporarily reserved for Public Purposes and Recreation by Orders in Council of 30 December, 1927 (vide Government Gazette of 6 January, 1928 – page 30) and 27 May, 1930 (vide Government Gazette of 4 June, 1930 – page 1616) [Rs 3594].</p>	<p>Pax Hill Scout Camp Committee of Management Incorporated</p>	<p>Barry Ernest LEACH</p>
<p>Tarrington Public Park and Recreation Reserves — The lands in the Parish of Hamilton South temporarily reserved for Public Park and Recreation by Orders in Council of 2 December, 1980 (vide Government Gazette of 10 December, 1980 – page 4223) and 18 January, 1994 (vide Government Gazette of 20 January, 1994 – page 224) [Rs 3329].</p>	<p>Tarrington Public Park and Recreation Reserve Incorporated</p>	<p>Geoff MIBUS</p>
<p>Purnim Public Hall Reserve — The land in the Parish of Purnim temporarily reserved for a Public Hall by Order in Council of 14 October, 1958 (vide Government Gazette of 22 October, 1958 — page 3429) [Rs 7766].</p>	<p>Purnim Mechanics Institute Incorporated</p>	<p>Ray ECCLES</p>
<p>Lower Cape Bridgewater Hall and Recreation Reserve — The remaining land in the Parish of Tarragal temporarily reserved for a Public Hall and Public Recreation by Order in Council of 18 August, 1953 (vide Government Gazette of 26 August, 1953 — page 4381) [Rs 5236].</p>	<p>Lower Cape Bridgewater Hall and Recreation Reserve Incorporated</p>	<p>Neil David WILLIAMSON</p>

This Order is effective from the date on which it is published in the Government Gazette.

Dated 7 May 2002

Responsible Minister
SHERRYL GARBUTT
Minister for Environment
and Conservation

HELEN DOYE
Clerk of the Executive Council

**SUBORDINATE LEGISLATION ACT 1994
NOTICE THAT STATUTORY RULES ARE
OBTAINABLE**

Notice is hereby given under Section 17 (3) of the **Subordinate Legislation Act 1994** that the following Statutory Rules were first obtainable from Information Victoria, 356 Collins Street, Melbourne on the date specified:

30. <i>Statutory Rule:</i>	Subordinate Legislation (Park Regulations 1992 – Extension of Operation) Regulations 2002
<i>Authorising Act:</i>	Subordinate Legislation Act 1994
<i>Date first obtainable:</i>	7 May 2002
<i>Code A</i>	

As from 1 April 2002, the pricing structure for the Victoria Government Gazette and Victorian Government Legislation will be as follows.

Retail price will vary according to the number of pages in each special or periodical gazette. The table below sets out the prices that apply.

<i>Price Code</i>	<i>No. of Pages (Including cover and blank pages)</i>	<i>Price*</i>
A	1–16	\$3.65
B	17–32	\$5.40
C	33–48	\$7.40
D	49–96	\$11.50
E	97–144	\$14.85
F	145–192	\$17.55
G	193–240	\$20.25
H	241–288	\$21.55
I	289–352	\$24.25
J	353–416	\$28.35
K	417–480	\$32.35
L	481–544	\$37.75
M	545–608	\$43.15
N	609–672	\$48.55
O	673–736	\$53.90
P	737–800	\$59.30

**All Prices Include GST*

ADVERTISERS PLEASE NOTE

As from 9 May 2002

The last Special Gazette was No. 78 dated 7 May 2002

The last Periodical Gazette was No. 1 dated 29 May 2001

CONTENTS

	Page
Estates of Deceased Persons	827
Government and Outer Budget Sector	
Agencies Notices	840
Orders in Council	860
Acts — Cemeteries; Land; Crown Land (Reserves); State Aid to Religion Abolition	
Private Advertisements	827
Proclamations	839

The Victoria Government Gazette is published by The Craftsman Press Pty. Ltd. with the authority of the Government Printer for the State of Victoria
© State of Victoria 2002

ISSN 0819-5471

This publication is copyright. No parts may be reproduced by any process except in accordance with the provisions of the Copyright Act.

Products and services advertised in this publication are not endorsed by The Craftsman Press Pty. Ltd. or the State of Victoria and neither of them accepts any responsibility for the content or the quality of reproduction. The Craftsman Press Pty. Ltd. reserves the right to reject any advertising material it considers unsuitable for government publication.

Address all enquiries to the Government Printer for the State of Victoria
Government Information and Communications Branch
Department of Premier and Cabinet
Level 3, 356 Collins Street
Melbourne 3000
Victoria Australia

RETAIL SALES

Information Victoria Bookshop
356 Collins Street Melbourne 3000.
Telephone enquiries 1300 366 356

City Graphics
Level 1, 520 Bourke Street
Melbourne 3000
Telephone enquiries (03) 9600 0977

Recommended Retail Price \$1.85 (includes GST)

Government and Outer Budget Sector Agencies please note:
STYLE REQUIREMENTS.

To ensure that material received can be reproduced, and that errors are minimised, the following guidelines are to be observed when submitting material by fax.

Fax resolution:

Material sent by fax should be transmitted using Fine Resolution (200 dots per inch by 200 dpi).

Font size:

Use 12 point (10 pitch) or larger.

Font Style:

Clear plain font styles, such as Helvetica, should be used.

Graphics:

Line drawings should be transmitted as large as possible to ensure clarity. Drawings up to A4 size sent by fax using Fine Resolution provide a good quality for reproduction.

Avoid:

Italics, underlining and full justification.

Ensure document is square when sending as documents that are sent skewed are difficult to read and process.

ISSN 0819-5471



9 770819 549229