



# Victoria Government Gazette

By Authority of Victorian Government Printer

**No. G 42 Thursday 16 October 2003**

[www.gazette.vic.gov.au](http://www.gazette.vic.gov.au)

**GENERAL**

---

---

**TABLE OF PROVISIONS**

---

Private Advertisements		Unclaimed Moneys	
Dissolution of Partnerships		Andrew McMath Real Estate Pty Ltd	2617
Values for Life	2612	Charles Tinney & Associates	2617
Viticulturists from Ceduna	2612	Housing Guarantee Fund Ltd	2617
Wandin Valley Farms	2612	Jellis Craig & Co.	2618
Estates of Deceased Persons		K. E. Software	2618
Arthur J. Dines & Co.	2612	Newton Real Estate	2618
Borchard & Moore	2612	Orica Limited	2619
Burke & Associates	2612	P. R. Rule—Barrister & Solicitor	2622
Davine Fitzpatrick	2613	Proclamations	2623
De Marco & Co.	2613	Government and Outer Budget Sector	
Ellinghaus Weill	2613	Agencies Notices	2625
Gray Friend & Long	2613	Orders in Council	2648
Harris & Chambers	2613	Acts: Crown Land (Reserves);	
Ingpen & Bent	2614	Interpretation of Legislation	
Littleton Hackford	2614		
Mulcahy Churkovich	2614		
Peter Gardiner	2614		
Pietrzak	2614		
Rigby Cooke	2615		
Rigby M. Cook & Associates	2615		
Theresa Teriana Uluave	2615		
Verna A. Cooke	2615		
Williams Winter	2615		
Wills & Probate Victoria	2615		
Wisewoulds	2616		
Wright Smiths	2616		

---

**Advertisers Please Note**

As from 16 October 2003

The last Special Gazette was No. 185 dated 10 October 2003.

The last Periodical Gazette was No. 1 dated 12 June 2003.

---



---

**How To Submit Copy**

- See our webpage [www.craftpress.com.au](http://www.craftpress.com.au)
  - or contact our office on 9926 1233  
between 8.30 am and 5.30 pm Monday to Friday
-

**PUBLICATION OF THE VICTORIA GOVERNMENT GAZETTE (GENERAL)  
MELBOURNE CUP HOLIDAY (Tuesday 4 November 2003)**

**Please Note:**

The Victoria Government Gazette for Melbourne Cup week will be published on **Thursday 6 November 2003**.

**Copy deadlines:**

Private Advertisements **9.30 am on Friday 31 October 2003.**

Government and Outer

Budget Sector Agencies Notices **9.30 am on Monday 3 November 2003.**

Where urgent gazettal is required after hours, arrangements should be made with the Government Gazette Officer on 0419 327 321.

JENNY NOAKES  
Government Gazette Officer

---

### PRIVATE ADVERTISEMENTS

#### DISSOLUTION OF PARTNERSHIP

Notice is hereby given that the partnership commencing on or about 1 January 2001 between Karen Louise Brunskill and Lori Alison Head, trading as "Values for Life" and carrying on business at 20 Mooroolbark Terrace, Mooroolbark, Victoria, is dissolved as from 4 August 2003, and that the said business is continuing to be conducted by Karen Louise Brunskill.

SHARROCK PITMAN, lawyers,  
1st Floor, 53 Kingsway, Glen Waverley 3150.

#### DISSOLUTION OF PARTNERSHIP

Notice is hereby given that the partnership heretofore subsisting between Peter Colwell Watkins and Lorraine Anne Watkins of "Illalangi", 2 Hidden Valley Boulevard, Wallan and Ian Maxwell Laird and Jacqueline Patricia Laird of "Ceduna", 910 Old Toolangi Road, Dixons Creek, carrying on business as viticulturists from "Ceduna", 910 Old Toolangi Road, Dixons Creek, has been dissolved as and from 7 October 2003. All claims and all correspondence relating to the partnership after that date should be addressed to Ian Maxwell Laird and Jacqueline Patricia Laird of "Ceduna", 910 Old Toolangi Road, Dixons Creek.

DAVIES ELLIOTT, solicitors  
250 Lower Heidelberg Road, East Ivanhoe,  
Victoria 3079.

#### DISSOLUTION OF PARTNERSHIP

Notice is hereby given that the partnership of C. L. Burgi & L. M. Burgi & P. J. Burgi & T. A. Burgi & Chapman Bros. Pty Ltd & B. S. Gaudion & E. J. Gaudion & G. J. Gaudion & J. Gaudion & K. R. Gaudion & Gruyere Estates Pty Ltd & G. C. Sebire & E. W. Sebire & Manthy Pty Ltd and Stemlink Pty Ltd trading under the business name of Wandin Valley Farms was dissolved as from 1 July 2003. The dissolution was a result of the retirement of Stemlink Pty Ltd from the partnership.

ALAN CHARLES FREDERICK BELGER,  
late of 114 Pindari Avenue, Mill Park, in the  
State of Victoria, pensioner, deceased. Creditors,

next-of-kin and others having claims in respect of the estate of the deceased, who died on 6 June 2003, are required by the executrix, Terri Pamela Oakley, care of Arthur J. Dines & Co., solicitors, 2A Highlands Road, Thomastown, in the said State, to send particulars to her by 17 December 2003 after which date the executrix may convey or distribute the assets having regard only to the claims to which she has notice.

Dated 9 October 2003

ARTHUR J. DINES & CO., solicitors,  
2A Highlands Road, Thomastown 3074.

Re: VIOLET ETHEL EDITH BURRELL,  
late of Unit 39, Parkglenn Retirement Community,  
360 Cheltenham Road, Keysborough, Victoria,  
but formerly of 6 Kurt Place, Noble Park,  
Victoria, widow, deceased.

Creditors, next-of-kin and others having claims in respect of the estate of the deceased, who died on 24 August 2003, are required by the trustee, Peter Maxwell Thomas Frost of 6 Kurt Place, Noble Park, Victoria, fitter and turner, to send particulars to the trustee by 29 December 2003 after which date the trustee may convey or distribute the assets, having regard only to the claims of which the trustee has notice.

BORCHARD & MOORE, solicitors,  
44 Douglas Street, Noble Park 3174.

Re: HAROLD JAMES BURNS, late of  
Chatham Lea Hostel, 13 Chatham Road,  
deceased.

Creditors, next-of-kin and others having claims in respect of the estate of the deceased, who died on 22 July 2003, are required by the trustee, Catherine Mary Mendes of 11 Culbara Drive, Vermont, to send particulars to the trustee C/- Burke & Associates, solicitors of 1127 High Street, Armadale, by 14 December 2003 after which date the trustee may convey or distribute the assets, having regard only to the claims of which the trustee has noted.

BURKE & ASSOCIATES, solicitors,  
1127 High Street, Armadale 3143.

Re: MELVINA PEARL ALICE THOMAS, late of 10 Devonshire Road, East Malvern, deceased.

Creditors, next-of-kin and others having claims in respect of the estate of the deceased, who died on 9 July 2003, are required by the trustees, Barry & Loyus Jean Aikman, both of 6 Pambarra Court, Donvale, to send particulars to the trustees C/- Burke & Associates, solicitors of 1127 High Street, Armadale, by 14 December 2003 after which date the trustees may convey or distribute the assets, having regard only to the claims of which the trustees have noted.

BURKE & ASSOCIATES, solicitors,  
1127 High Street, Armadale 3143.

---

Re: RUDI HERMANN HESS, late of 48 Sherrin Street, Morwell, Victoria 3840, retired fitter/turner, deceased.

Creditors, next-of-kin and others having claims in respect of the estate of RUDI HERMANN HESS, deceased, who died on 12 August 2003, are required by the trustees, Ian Gordon Johnston and Jennifer Alvina Hess, to send particulars to the trustees care of the belowmentioned solicitors by 17 December 2003 after which date the trustees may convey or distribute the assets, having regard only to the claims of which the trustees have notice.

DAVINE FITZPATRICK, solicitors,  
Level 1, 32 Kay Street, Traralgon.

---

Re: SHIRLEY IRENE LAPETINA, late of Delbridge Gardens Hostel, 50 Community Hub, Sydenham, Victoria, retired machinist, deceased. Creditors, next-of-kin and others having claims in respect of the estate of the deceased, who died on 25 July 2003, are required by the trustee, Vincent Peter John Lapetina of 87B Doncaster Street, Ascot Vale, Victoria, to send particulars to the trustee within 60 days from the publication hereof after which date the trustee may convey or distribute the assets, having regard only to the claims of which the trustee has notice.

DE MARCO & CO., solicitors,  
209 Glenroy Road, Glenroy 3046.

---

JEAN MARGARET DOWSLEY, late of Apartment 1, The Connault, 41-45 Yarrbat Avenue, Balwyn, home duties, deceased.

Creditors, next-of-kin and others having claims in respect of the estate of the deceased, who died on 12 July 2003, are required by the personal representatives, Equity Trustees Limited of Level 2, 575 Bourke Street, Melbourne, to send particulars to them care of the undermentioned solicitors by 24 December 2003 after which date the personal representatives may convey or distribute the assets having regard only to the claims of which they then have notice.

ELLINGHAUS WEILL, solicitors,  
79-81 Franklin Street, Melbourne 3000.

---

MYRTLE JEAN McRAE, (in the Will called Jean Myrtle McRae and also known as Jeanne McRae and Jean McCrae), late of 45 Sylvan Road, Wattle Glen, gentlewoman, deceased. Creditors, next-of-kin and others having claims in respect of the estate of the deceased, who died on 20 September 2002, are required by the personal representatives, Kenneth McRae Forge of 14 Berry Street, East Melbourne and Kristine Gale Hosking of 3 Locksley Road, Ivanhoe, to send particulars to them care of the undermentioned solicitors by 24 December 2003 after which date the personal representatives may convey or distribute the assets having regard only to the claims of which they then have notice.

ELLINGHAUS WEILL, solicitors,  
79-81 Franklin Street, Melbourne 3000.

---

GRAHAM THOMAS MARKS, late of Jacksons Track, Labertouche, farmer, deceased. Creditors, next-of-kin and others having claims in respect of the estate of the deceased, who died on 30 May 2003, are required by the trustees, Douglas Harold Worboys and Michaela Ruth Whiting, to send particulars of their claims to them care of the undersigned by 16 December 2003 after which date the trustees may convey or distribute the assets having regard only to the claims of which they then have notice.

GRAY FRIEND & LONG solicitors,  
70 Queen Street, Warragwa 3820.

---

BESSIE BARTLETT WHITE, late of Broughton Hall, 2 Berwick Street, Camberwell, artist, deceased. Creditors, next-of-kin and

others having claims in respect of the estate of the deceased, who died on 21 September 2003, are required by the trustees, care of Harris & Chambers, lawyers, of 338 Charman Road, Cheltenham, to send particulars to them by 17 December 2003 after which date the trustees may convey or distribute the assets, having regard only to the claims of which they then have notice.

HARRIS & CHAMBERS, lawyers,  
338 Charman Road, Cheltenham 3192.

---

LAURIE PERCY HINKS, late of Kingston Centre, Warrigal Road, Cheltenham. Creditors, next-of-kin and others having claims in respect of the estate of the deceased, who died on 18 September 2003, are required by the trustee, care of Harris & Chambers, lawyers, of 338 Charman Road, Cheltenham, to send particulars to them by 17 December 2003 after which date the trustee may convey or distribute the assets, having regard only to the claims of which he then has notice.

HARRIS & CHAMBERS, lawyers,  
338 Charman Road, Cheltenham 3192.

---

JOAN MURCH, late of 26 Eastern Beach, Geelong, gentlewoman deceased. Creditors, next-of-kin and others having claims in respect of the estate of the abovenamed deceased, who died on 2 July 2003, are required by the trustees, Jillian Maie Cameron Murray of 26 Eastern Beach, Geelong, home duties and Colin Ernest Brown of 32 Powell Street West, Ocean Grove, accountant, to send particulars of their claims to the trustees care of the undermentioned legal practitioners by 7 January 2004, after which date the trustees may convey or distribute the assets having regard only to the claims of which they then have notice.

INGPEN & BENT, legal practitioners,  
95 Yarra Street, Geelong,  
Legal practitioners for the trustees.

---

Creditors, next-of-kin and others having claims in respect of the estate of DANIEL AMBROSE RYAN, late of 2 Gordon Street, Traralgon, Victoria, retired, deceased, who died on 11 August 2003, are to send their claims to the trustee, Theresia Ryan of 2 Gordon Street, Traralgon, Victoria, care of the belowmentioned

solicitors by 15 December 2003 after which date she will distribute the assets of the deceased having regard only to the claims of which she then has notice.

LITTLETON HACKFORD, solicitors,  
Law Chambers,  
115 Hotham Street, Traralgon, Vic. 3844.

---

MARGARET ELLEN HOLMES, late of 37 Douglas Street, Toorak, Victoria, widow. Creditors, next-of-kin and others having claims in respect of the estate of the deceased, who died on 26 July 2003, are required by the trustee to send particulars to her by 16 December 2003 after which date the trustee may convey or distribute the assets having regard only to the claims of which she then has notice.

Dated 16 October 2003

MULCAHY CHURKOVICH, lawyers,  
9/493 Toorak Road, Toorak 3142.

---

Creditors, next-of-kin and others having claims against the estate of RAGLAN FITZROY SOMERSET, late of 67 Westering Road, Christmas Hills, in the State of Victoria, medical practitioner, deceased, who died on 23 October 2002, are required to send particulars of their claims to the executrix, Lenore Beatrice Somerset, care of the undermentioned solicitor by 22 December 2003 after which date she will distribute the estate of the deceased having regard only to the claims of which she then has notice.

PETER GARDINER, solicitor,  
Office 1, 2 Colin Avenue, Warrandyte 3113.

---

Creditors, next-of-kin and others having claims in respect of the estate of EUGENIA GODLEWSKA, late of 74 Devonshire Road, Sunshine, in the State of Victoria, pensioner, deceased, who died on 28 September 2003, are required to send particulars of such claims to the executor care of the undermentioned solicitors by 16 December 2003 after which date the executor will convey or distribute the assets having regard only to the claims of which the executor then has notice.

PIETRZAK, solicitors,  
222 Latrobe Street, Melbourne.

---

Creditors, next-of-kin and others having claims in respect of the estate of WOJTEK JOHN OSTROWSKI, also known as Wojciech John Ostrowski, late of 3/52 Leumear Street, Clayton South, in the State of Victoria, consultant, deceased, who died on 30 June 2003, are required to send particulars of such claims to the executor care of the undermentioned solicitors by 16 December 2003 after which date the executor will convey or distribute the assets having regard only to the claims of which the executor then has notice.

PIETRZAK, solicitors,  
222 Latrobe Street, Melbourne.

---

Creditors, next-of-kin or others having claims in respect of the estate of AGNES JANE TAYLOR, late of Arcare, 346 South Road, Hampton East, Victoria, but formerly of 15 Walsal Avenue, Reservoir, Victoria, widow, deceased, who died on 1 August 2003, are to send particulars of their claims to the executors care of the undermentioned solicitors by 18 December 2003 after which date the executors will distribute the assets having regard only to the claims of which the executors then have notice.

RIGBY COOKE, solicitors,  
469 La Trobe Street, Melbourne 3000.

---

Re: Estate of HARRINGTON BERTHA MACMILLAN, deceased.

Creditors, next-of-kin or others having claims in respect of the estate of HARRINGTON BERTHA MACMILLAN, of 41 Gowrie Avenue, Frankston, in the State of Victoria, widow, who died on 6 May 2003, are to send particulars of their claims to the personal representative/s care of the undermentioned solicitors by 25 December 2003 after which date the personal representative/s will distribute the assets having regard only to the claims of which they then had notice.

RIGBY M. COOK & ASSOCIATES,  
Barristers & solicitors,  
Level 19, AMP Tower,  
535 Bourke Street, Melbourne, Vic. 3000.

---

JAMES BENJAMIN NOMANI ULUAVE, late of 3/11 Rosstown Road, Carnegie, Victoria 3163, musician, deceased.

Creditors, next-of-kin and others having claims in respect of the estate of the said deceased, who died on 10 April 2003, are required by the personal representative, Theresa Teriana Uluave of 3 Taharangi Street, Rotorua, New Zealand, widow, to send particulars of their claims to her by 18 December 2003 after which date the personal representative may convey or distribute the assets, having regard only to the claims of which she then has notice.

---

PATRICIA MARY WHITEHEAD, deceased.

Creditors, next-of-kin and others having claims against the estate of PATRICIA MARY WHITEHEAD, late of 32A St Vincent Place, Albert Park, Victoria, widow, deceased, who died on 14 June 2003, are required to send particulars of their claims to the executors care of the undermentioned solicitor by 28 December 2003 after which date the executors will proceed to distribute the assets having regard only to the claims of which they shall then have had notice.

VERNA A. COOK, solicitor,  
5/8 St Andrews Street, Brighton 3186.

---

Re: MARJORIE BEATRICE BOOTH, deceased.

Creditors, next-of-kin and others having claims in respect of the estate of the abovenamed deceased, who died on 17 July 2003, are required by the trustee Equity Trustees Limited of Level 2, 575 Bourke Street, Melbourne, to send particulars of their claims to the trustee by 15 December 2003 after which date the trustee may convey or distribute the assets of the estate having regard only to the claims of which the trustee then has notice.

WILLIAMS WINTER, solicitors,  
377 Lonsdale Street, Melbourne.  
Solicitors for the trustee.

---

Re: STEPHEN AVISON PARKER, late of 3A Wiseman Street, Hawthorn East, Victoria. Creditors, next-of-kin and others having claims in respect of the estate of the deceased, who died on 2 July 2003, are required to send particulars

of their claims to the executor, C/- Wills & Probate Victoria, lawyers, GPO Box 1946, Melbourne, Victoria 3001 by 19 December 2003 after which date the executor may convey or distribute the assets having regard only to the claims of which he may then have notice.

WILLS & PROBATE VICTORIA, lawyers,  
Level 5, 360 Little Bourke Street, Melbourne.

---

GEOFFREY GORDON HOWELL, late of 4/23 Asquith Street, Kew, Victoria, grazier, deceased. Creditors, next-of-kin and others having claims in respect of the estate of the abovenamed deceased, who died on 7 August 2003, are required by the executor, Warwick John Dick of 46 Childers Street, Kew, to send particulars to the executor by 19 December 2003 after which date the executor intends to convey or distribute the assets of the estate having regard only to the claims of which the executor may have notice.

WISEWOULDS, solicitors,  
459 Collins Street, Melbourne.

---

Re: MARGARET EDNA CHAMBERS, late of 22 Keogh Street, Rosebud, Victoria, widow, deceased.

Creditors, next-of-kin and others having claims in respect of the estate of the deceased, who died on 2 March 2003, are required by the trustee, Kim Syme Price, to send particulars to the trustee C/- the undermentioned solicitors by 17 December 2003 after which date the trustee may convey or distribute the assets, having regard only to the claims of which the trustee has notice.

WRIGHT SMITHS, solicitors,  
2 Seventh Avenue, Rosebud 3939.

---



**Unclaimed Moneys Act 1962**

Register of Unclaimed Moneys held by the —

<i>Name of Owner on Books and Last Known Address</i>	<i>Total Amount Due to Owner</i>	<i>Description Of Unclaimed Money</i>	<i>Date when Amount first became Payable</i>
ANDREW McMATH REAL ESTATE PTY LTD			
	\$		
Andrew Keith McKenzie Halliday & Julie Anne Kentish Halliday, 1 Whipbird Court, Rowville	100.00	Cheque	28/05/98
Paul Anthony Barnard, 38 Beech Drive, Byron Hills, NSW	200.00	"	22/10/96

03249

CONTACT: JANE NUNN, PHONE: (03) 5967 1800.

**Unclaimed Moneys Act 1962**

Register of Unclaimed Moneys held by the —

<i>Name of Owner on Books and Last Known Address</i>	<i>Total Amount Due to Owner</i>	<i>Description Of Unclaimed Money</i>	<i>Date when Amount first became Payable</i>
CHARLES TINNEY & ASSOCIATES			
	\$		
Christopher John Callinan & Bernadette Mary Callinan 33 Crana Grove, Greensborough	204.00	Cheque	27/08/01

03277

CONTACT: ANGELA BURNS/DESE BRIGGS, PHONE: (03) 9432 3131.

**Unclaimed Moneys Act 1962**

Register of Unclaimed Moneys held by the —

<i>Name of Owner on Books and Last Known Address</i>	<i>Total Amount Due to Owner</i>	<i>Description Of Unclaimed Money</i>	<i>Date when Amount first became Payable</i>
HOUSING GUARANTEE FUND LTD			
	\$		
S. & L. Gregorczy, 3 Casuarina Court, Traralgon	620.00	Cheque	13/09/00

03225

CONTACT: DAVID YEE, PHONE: (03) 9660 6253.

**Unclaimed Moneys Act 1962**

Register of Unclaimed Moneys held by the —

<i>Name of Owner on Books and Last Known Address</i>	<i>Total Amount Due to Owner</i>	<i>Description Of Unclaimed Money</i>	<i>Date when first became Payable</i>
JELLIS CRAIG & CO.			
	\$		
Richard John Green, C/- 25 Limassol Court, Donvale 03275 CONTACT: KIM WILKIE & WENDY FITZSIMONS, PHONE: (03) 9818 2222.	7,619.96	Cheque	20/12/00

**Unclaimed Moneys Act 1962**

Register of Unclaimed Moneys held by the —

<i>Name of Owner on Books and Last Known Address</i>	<i>Total Amount Due to Owner</i>	<i>Description Of Unclaimed Money</i>	<i>Date when first became Payable</i>
KE SOFTWARE			
	\$		
Peter Reynolds, 52 Gipps Street, East Melbourne	1,200.00	Cheque	24/04/98
Peter Reynolds, 52 Gipps Street, East Melbourne	1,800.00	"	09/06/99
03241 CONTACT: JOHN DOOLAN, PHONE: (03) 9347 8844.			

**Unclaimed Moneys Act 1962**

Register of Unclaimed Moneys held by the —

<i>Name of Owner on Books and Last Known Address</i>	<i>Total Amount Due to Owner</i>	<i>Description Of Unclaimed Money</i>	<i>Date when first became Payable</i>
NEWTON REAL ESTATE PTY LTD			
	\$		
Giang	200.00	Cheque	18/02/99
Hung	100.00	"	18/07/99
Sao	200.00	"	02/08/99
So Thea	200.00	"	26/09/99
Ly & Lim	200.00	"	21/02/00
03274 CONTACT: DON FRASER, PHONE: (03) 9791 4444.			

**Unclaimed Moneys Act 1962**

Register of Unclaimed Moneys held by the —

<i>Name of Owner on Books and Last Known Address</i>	<i>Total Amount Due to Owner</i>	<i>Description Of Unclaimed Money</i>	<i>Date when first became Payable</i>
ORICA LIMITED			
	\$		
Animedra Pty Ltd, 112 Crescent Road, Hamilton, Qld	176.24	Cheque	06/07/01
Cadzow Pty Ltd, 23 Peacock Parade, Frenchs Forest, NSW	271.20	"	"
Cadzow Pty Ltd, 23 Peacock Parade, Frenchs Forest, NSW	271.20	"	17/12/01
Colehurst Nominees Pty Ltd & Mrs Edith Elizabeth Langdon, "T. F. Account", PO Box 1151, Crows Nest, NSW	120.00	"	06/07/01
Datanvest Ltd, C/- Mr Rick Howell, PO Box 71332, Dubai, United Arab Emirates	120.00	"	"
Datanvest Ltd, C/- Mr Rick Howell, PO Box 71332, Dubai, United Arab Emirates	120.00	"	17/12/01
Dr Michael John Lannan, 8/4 Karla Avenue, Terrigal, NSW	800.00	"	06/07/01
Dr Pamela Woodruff & Miss Elissa Jane Woodruff, "Woodruff Super Fund A/c", Unit 4, 2 Holdsworth Avenue, Elizabeth Bay, NSW	240.00	"	"
Dr Sharon Margaret Lamb, 8 St Helens Place, North Geelong	1,648.13	"	19/09/01
Est Alixs C. G. Goetze, C/- Minter Ellison, GPO Box A39, Perth, WA	150.48	"	06/07/01
Est George H. Hutchinson, PO Box 2732, Mount Isa, Qld	122.48	"	"
Est George H. Hutchinson, PO Box 2732, Mount Isa, Qld	122.48	"	17/12/01
Est Giovanni Morzone, C/- John M. Scott, PO Box 989, Ingham, Qld	646.28	"	26/09/01
Est Margaret B. Mather, C/- Perpetual Tasmania Funds Management, GPO Box 227, Hobart, Tas.	220.24	"	06/07/01
Est Margaret Sweeney, 3 Monomeeth Place, Miranda, NSW	320.00	"	"
Est Mrs Margaret Mary Perry, C/- Mr S. R. Perry, 133 Merrivale Lane, Turrumurra, NSW	400.00	"	17/12/01
Graphitype Professional, Graphic Service Pty Ltd, "Super Fund A/c", PO Box 286, Baulkham Hills, NSW	280.00	"	06/07/01
J. G. Cruett Nominees Pty Ltd, "J. G. Cruett Family A/c", 41 Military Road, Tennyson, SA	160.00	"	"
J. G. Cruett Nominees Pty Ltd, "J. G. Cruett Family A/c", 41 Military Road, Tennyson, SA	160.00	"	17/12/01
Lockley Services Pty Ltd, 8 Macro Court, Rowville	160.00	"	06/07/01
Lockley Services Pty Ltd, 8 Macro Court, Rowville	160.00	"	17/12/01
Miss Florence M. Carter, 600 Henry Lawson Drive, East Hills, NSW	200.00	"	06/07/01
Miss Suzanne Gai Baldwin, Unit 10, 8 Thibault Street, Tamworth, NSW	116.00	"	"
Miss Suzanne Gai Baldwin, Unit 10, 8 Thibault Street, Tamworth, NSW	116.00	"	17/12/01

Mr Andrew Graham Jeffers, 37 The Comenarra Parkway, Thornleigh, NSW	120.00	”	17/12/01
Mr Angelo Labriola, C/- PT Orica Mining Services, 4th Floor, Sentral Senayan, IJI Asia-Afrika No 8, Jakarta 10270, Indonesia	200.00	”	06/07/01
Mr Angelo Labriola, C/- PT Orica Mining Services, 4th Floor, Sentral Senayan IJI Asia-Afrika No 8, Jakarta 10270, Indonesia	200.00	”	17/12/01
Mr Angus Campbell McKechnie, 15/449 St Kilda Road, Melbourne	120.00	”	06/07/01
Mr Angus Campbell McKechnie, 15/449 St Kilda Road, Melbourne	120.00	”	17/12/01
Mr Bharat Patel & Mrs Pratibha Patel, “Patel Super Fund A/c”, 49 Chilton Pde, Warrawee, NSW	160.00	”	06/07/01
Mr Brian Alan Faulls, 143C Memorial Avenue, Christchurch, New Zealand	200.00	”	”
Mr Bruce Chalker, 3/78 Eyre Street, North Ward, Qld	858.32	”	”
Mr Bruce Chalker, 3/78 Eyre Street, North Ward, Qld	858.32	”	17/12/01
Mr Bruce Foy, “Cecilton Super Fund A/c”, C/- Financial Synergy Pty Ltd, PO Box 7334, St Kilda Road, Melbourne	400.00	”	06/07/01
Mr Clifford J. Kitchen, Unit 27, 50 Aubin Street, Neutral Bay, NSW	107.28	”	”
Mr Clifford J. Kitchen, Unit 27, 50 Aubin Street, Neutral Bay, NSW	107.28	”	17/12/01
Mr David Christopher Mackie, Apt 371/299 Spring Street, Melbourne	160.00	”	06/07/01
Mr David Richardson & Mrs Louise Richardson, 38 Reynolds Parade, Pascoe Vale South	1,021.11	”	26/09/01
Mr Dinh Hoang Nguyen, 8 Waterview Street, Putney NSW	160.00	”	06/07/01
Mr Eigil Nielsen, Level 19, 20 Bond Street, Sydney, NSW	128.00	”	”
Mr Eigil Nielsen, Level 19, 20 Bond Street, Sydney, NSW	128.00	”	17/12/01
Mr Gary Brown & Ms Sally Van Nooten, “Van Brown Super Fund A/c”, C/- Watson Wyatt Aust P/L, 1 Collins Street Melbourne	120.00	”	06/07/01
Mr Gregory Prowse & Mrs Sonya Jeanette Prowse, “Prowse Family S/Fund A/c”, 5 Cabramatta Road, Cronulla, NSW	160.00	”	17/12/01
Mr Henry Frederick Hopkins, 5 Loloma Court, Burwood	212.48	”	06/07/01
Mr James Ainsworth, PO Box 770, Mount Isa, Qld	145.76	”	”
Mr James Ainsworth, PO Box 770, Mount Isa, Qld	145.76	”	17/12/01
Mr James Fitter, 68 Portland Road, Notting Hill W11 4IQ, London, UK	368.00	”	”
Mr James Peter Thomson, PO Box 9795, Frenchville, North Rockhampton, Qld	178.00	”	17/12/01
Mr John McSweeney, 69 St Clems Road, Doncaster East	1,391.65	”	26/09/01
Mr Leroy Chalker & Mrs June Chalker, 124 Darlington Road, N E Warren, Ohio 44484, USA	104.88	”	17/12/01
Mr Marc Petrus Habermehl, 93 Janet Street, Merewether, NSW	109.68	”	”
Mr Marek Janusz Kozlowski, 30 York Street, Beecroft, NSW	160.00	”	”
Mr Mark Perree & Mrs Jocelyn Perree, “Perree Family Super A/c”, 23 Ward Street, Ashburton	320.00	”	06/07/01

Mr Mark Woolley & Mrs Heather Joy Woolley, Unit 6, 31–35 Mary Street, Shellharbour, NSW	1,077.13	”	26/09/01
Mr Michael Robert Godfrey & Mr Deborah Anne Godfrey, 32 Northumberland Avenue, Mount Colah, NSW	112.00	”	17/12/01
Mr Ming Chan & Mr Ken Chan, “M & K Family A/c”, 29 The Esplanade, Mount Pleasant, WA	480.00	”	”
Mr Norman Robert Murphy & Miss Zhao Xia Liao, Unit 7, 14–16 Ramsay Street, Collaroy, NSW	160.00	”	06/07/01
Mr Peter Boyer & Mrs Edythe Boyer, C/- Sheraton Club Des Pins, B P 62 Staouli, Alger, Algeria	128.00	”	17/12/01
Mr Peter Edward Marchant, 400 Bruce Crescent, Wallarah, NSW	156.00	”	06/07/01
Mr Peter Edward Marchant, 400 Bruce Crescent, Wallarah, NSW	156.00	”	17/12/01
Mr Richard John Borland, 1–2A Dundas Road, Whangarei, Malaysia	244.00	”	”
Mr Roger William Brown, PO Box 5, Lyneham, ACT	129.04	”	06/07/01
Mr Roger William Brown, PO Box 5, Lyneham, ACT	129.04	”	17/12/01
Mr Ronald Toussaint, 48 Plymouth Court, Raby Bay, Qld	240.00	”	06/07/01
Mr Shane Noel Tyrrell, 15 Victor Avenue, Kew	160.00	”	17/12/01
Mr Tim John Ward, 4/24 Darrambal Street, Chevron Island, Qld	672.00	”	”
Mr Wayne Stewart, Flight Ops FC-449 Emirates, PO Box 92, Dubai, United Arab Emirates	120.00	”	”
Mr William Bull, 50 Blenheim Street, Croydon Park, NSW	169.52	”	”
Mr William Gerard McGuinness, 37 Flinders Street, Mentone	160.00	”	06/07/01
Mrs Barbara Mary Foo, C/- Mr Patrick Foo, ICI Office, Level 6, Tifa Building, JL Kuningan Barat 26, Jakarta 12710, Indonesia	112.00	”	”
Mrs Barbara Mary Foo, C/- Mr Patrick Foo, ICI Office, Level 6, Tifa Building, JL Kuningan Barat 26, Jakarta 12710, Indonesia	112.00	”	17/12/01
Mrs Clarice M. Layne, 20 Osborne Avenue, McKinnon	762.48	”	06/07/01
Mrs Colleen Bard-Brucker, “Bela Bard-Brucker S/F A/c”, PO Box 1176, Werribee Plaza, Werribee	267.13	”	26/09/01
Mrs Elizabeth Anne Waddell, Villa 8, Star Compound, PO Box 3843, Riyadh 11481, Saudi Arabia	136.00	”	06/07/01
Mrs Elizabeth Anne Waddell, Villa 8, Star Compound, PO Box 3843, Riyadh 11481, Saudi Arabia	136.00	”	17/12/01
Mrs Heather Edwina Cornish, Unit 3/123 Old Burleigh Road, Broadbeach, Qld	160.00	”	06/07/01
Mrs Jennine Blundell, 158 Hargrave Street, Paddington, NSW	128.00	”	17/12/01
Mrs Judith Hosier, “The Hosier Super Fund A/c”, 112 Crescent Road, Hamilton, Qld	261.28	”	06/07/01
Mrs Margaret Mary Vella, 25 Barton Street, Mackay, Qld	215.43	”	26/09/01
Mrs Mary Keeling, PO Box 553, Tewantin, Qld	160.00	”	17/12/01
Mrs Rita Henrietta Winterton, 90 Powell Street, Joondanna, WA	187.04	”	”
Mrs Rosslyn Dillon, 54 Ngunawal Drive, Isaacs, ACT	240.00	”	06/07/01
Mrs Valerie E. Greene, C/- Mr John C. M. Grant, 1 Pullenvale Road, Pullenvale, Qld	228.72	”	”
Mrs Valerie E. Greene, C/- Mr John C. M. Grant, 1 Pullenvale Road, Pullenvale, Qld	228.72	”	17/12/01
Mrs Wendy Loiterton, “Simon R. J. Loiterton A/c”, PO Box 964, Moss Vale, NSW	184.00	”	06/07/01
Mrs Wendy Loiterton, “Simon R. J. Loiterton A/c”, PO Box 964, Moss Vale, NSW	184.00	”	17/12/01

Oil & Gas Worx Pty Ltd, "Taylor Total Fund A/c", 44 Kooyongkoot Road, Hawthorn	160.00	"	06/07/01
Prof. Robert Goulston Gilbert, Chemistry School, University of Sydney, Sydney, NSW	384.00	"	17/12/01
Supa Stik Labels & Labelling Systems Pty Ltd, "Holywell Super Fund A/c", Private & Confidential, PO Box 712, Balcatta, WA	240.00	"	"
Sydney Dental Management Pty Ltd, "Michael Jackson Super A/c", PO Box 425, Granville, NSW	120.00	"	"
Taltrad Pty Limited, Unit 302, 620 St Kilda Road, Melbourne	343.04	"	06/07/01

03226

CONTACT: KAI DIEP, PHONE: (03) 9615 9950.

**Unclaimed Moneys Act 1962**

Register of Unclaimed Moneys held by the —

<i>Name of Owner on Books and Last Known Address</i>	<i>Total Amount Due to Owner</i>	<i>Description Of Unclaimed Money</i>	<i>Date when Amount first became Payable</i>
P. R. RULE—BARRISTER & SOLICITOR			
	\$		
Miss Marjorie Thompson	10,309.35	Cheque	20/11/01
Miss Christine McLaren	10,309.35	"	"

03276

CONTACT: P. R. RULE, PHONE: (03) 9470 5233.

**PROCLAMATIONS**

ACTS OF PARLIAMENT		
Proclamation		
I, Marigold Southey, Lieutenant-Governor of Victoria, as the Governor's deputy, declare that I have today assented in Her Majesty's name to the following Bills:		
No. 66/2003	<b>Constitution (Supreme Court) Act 2003</b>	No. 68/2003 (1) Subject to sub-section (2), this Act comes into operation on a day or days to be proclaimed. (2) If a provision of this Act does not come into operation before 30 June 2004, it comes into operation on that day.
No. 67/2003	<b>Health Legislation (Amendment) Act 2003</b>	No. 69/2003 (1) Subject to sub-section (2), this Act comes into operation on a day or days to be proclaimed. (2) If a provision of this Act does not come into operation before 1 February 2006, it comes into operation on that day.
No. 68/2003	<b>Human Services (Complex Needs) Act 2003</b>	
No. 69/2003	<b>Non-Emergency Patient Transport Act 2003</b>	
No. 70/2003	<b>Superannuation Acts (Family Law) Act 2003</b>	
No. 71/2003	<b>Supreme Court (Vexatious Litigants) Act 2003</b>	No. 70/2003 (1) Subject to this section, this Act comes into operation on the day after the day on which it receives the Royal Assent. (2) Sections 7(1), 11(1), 17(1), 29(1) and 40(1) are deemed to have come into operation on 30 June 1996. (3) Section 12 is deemed to have come into operation on 1 January 1994. (4) Section 21 is deemed to have come into operation on 16 June 1996. (5) Section 27 is deemed to have come into operation on 6 December 2000.
No. 72/2003	<b>Victorian Industry Participation Policy Act 2003</b>	
Given under my hand and the seal of Victoria at Melbourne on 14 October 2003.		
(L.S.)	MARIGOLD SOUTHEY Lieutenant-Governor as the Governor's deputy By His Excellency's Command	
	STEVE BRACKS MP Premier	
No. 66/2003	This Act comes into operation on the day after the day on which it receives the Royal Assent.	
No. 67/2003	(1) This Act, except section 6, comes into operation on the day after the day on which it receives the Royal Assent. (2) Subject to sub-section (3), sections 6 comes into operation on a day to be proclaimed. (3) If section 6 does not come into operation before 1 June 2004, it comes into operation on that day.	No. 71/2003 This Act comes into operation on the day after the day on which it receives the Royal Assent. No. 72/2003 (1) Subject to sub-section (2), this Act comes into operation on a day or days to be proclaimed. (2) If a provision of this Act does not come into operation before 1 January 2004, it comes into operation on that day.

**Australian Crime Commission  
(State Provisions) Act 2003**

PROCLAMATION OF COMMENCEMENT

I, Marigold Southey, Lieutenant-Governor of Victoria, as the Governor's deputy, with the advice of the Executive Council and under section 2(2) of the **Australian Crime Commission (State Provisions) Act 2003**, fix 16 October 2003 as the day on which items 11 and 14 of Schedule 1 to that Act come into operation.

Given under my hand and the seal of Victoria on 14 October 2003.

(L.S.)           MARIGOLD SOUTHEY  
Lieutenant-Governor,  
as the Governor's deputy  
By His Excellency's Command

ANDRÉ HAERMMEYER  
Minister for Police  
and Emergency Services

fix 16 October 2003 as the day on which Part 2 of that Act comes into operation.

Given under my hand and the seal of Victoria on 14 October 2003.

(L.S.)           MARIGOLD SOUTHEY  
Lieutenant-Governor,  
as the Governor's deputy  
By His Excellency's Command

ROB HULLS  
Attorney-General

**Health Legislation (Research Involving  
Human Embryos and Prohibition of Human  
Cloning) Act 2003**

PROCLAMATION OF COMMENCEMENT

I, Marigold Southey, Lieutenant-Governor of Victoria, with the advice of the Executive Council and under section 2 of the **Health Legislation (Research Involving Human Embryos and Prohibition of Human Cloning) Act 2003**, fix 16 October 2003 as the day on which that Act comes into operation.

Given under my hand and the seal of Victoria on 14 October 2003.

(L.S.)           MARIGOLD SOUTHEY  
Lieutenant-Governor,  
as the Governor's deputy  
By His Excellency's Command

BRONWYN PIKE  
Minister for Health

**Terrorism (Community Protection) Act 2003**

PROCLAMATION OF COMMENCEMENT

I, Marigold Southey, Lieutenant-Governor, as the Governor's deputy, with the advice of the Executive Council and under section 2(2) of the **Terrorism (Community Protection) Act 2003**,



**GOVERNMENT AND OUTER BUDGET  
SECTOR AGENCIES NOTICES**

**BAW BAW SHIRE COUNCIL**

Road Discontinuance

Pursuant to Sections 189, 206 and Schedule 10, Clause 3 of the **Local Government Act 1989**, the Baw Baw Shire Council, at its Ordinary meeting held on 24 September 2003, has formed the opinion that the road shown hatched on the plan below is not reasonably required as a road for public use and has resolved to discontinue the road and sell the land from the road to the abutting owners.

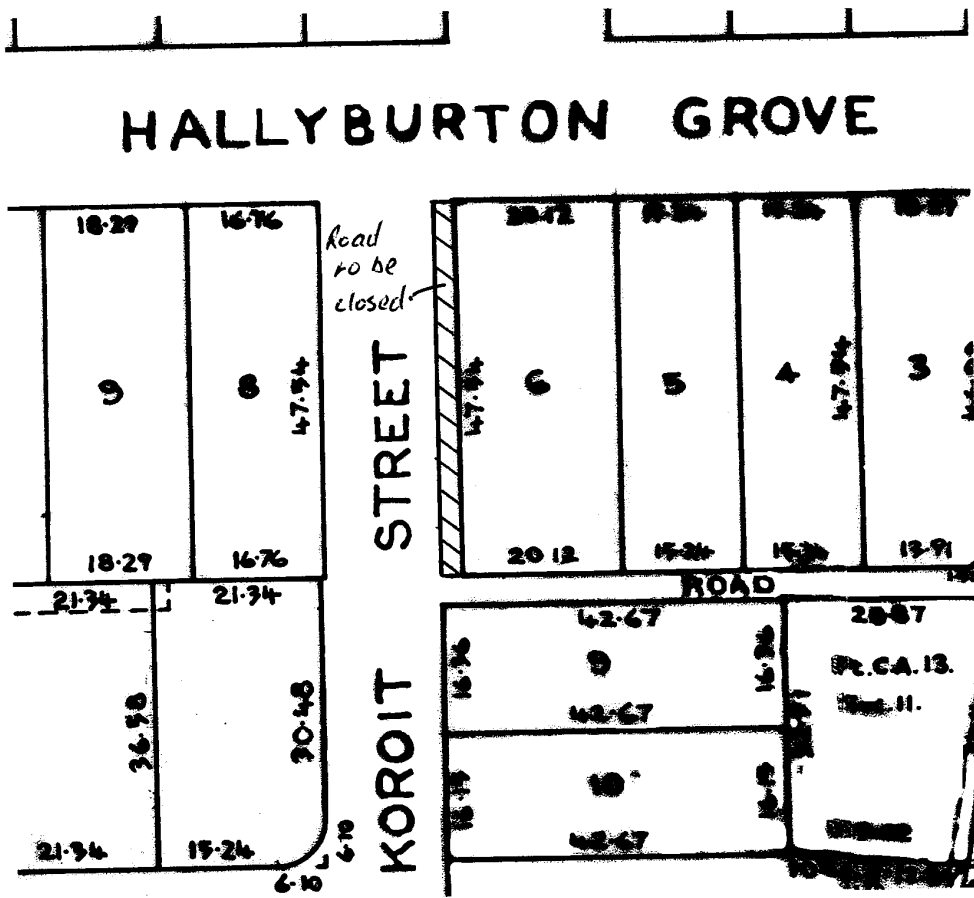

JOHN F. DYER  
Chief Executive Officer

**LATROBE CITY COUNCIL**

Road Discontinuance  
off Ethel Street, Traralgon

Pursuant to Section 206 and Schedule 10, Clause 3 of the **Local Government Act 1989**, the Latrobe City Council at its Ordinary meeting held on Monday 6 October 2003, formed the opinion

that a small section (approximately 13m<sup>2</sup>) of road off Ethel Street abutting Lot 26, LP 16004 and Lot 10, LP 25202 marked on the plan below is not required as a road for public use and resolved to discontinue the section of government road. The section of road off Ethel Street, Traralgon is to be sold by private treaty to an adjoining owner.

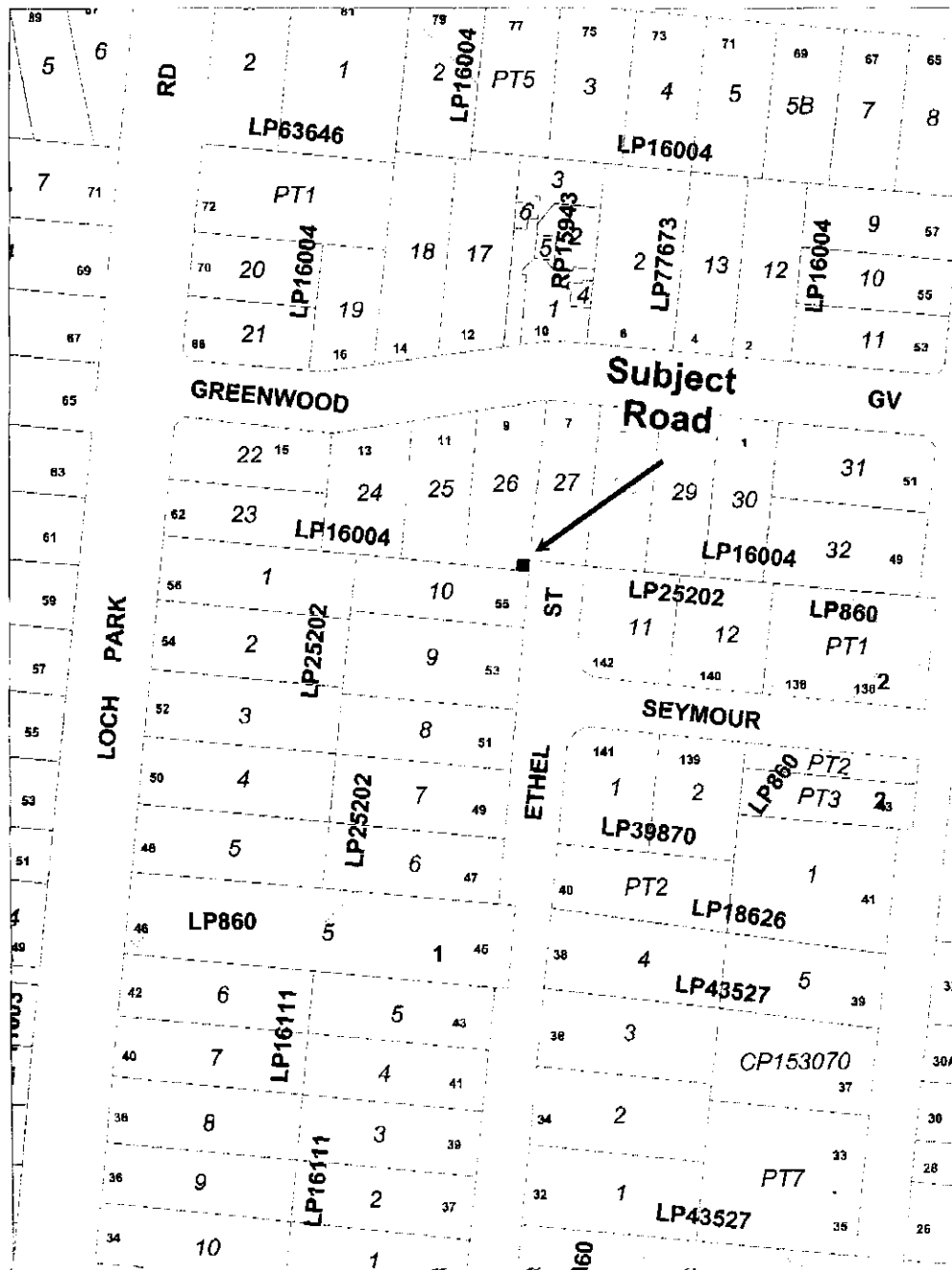

RICHARD HANCOCK  
Chief Executive Officer

GLEN EIRA CITY COUNCIL  
Road Discontinuance

Acting under Section 206 and Clause 3 of Schedule 10 to the **Local Government Act 1989**, Glen Eira City Council has resolved that the road shown by hatching and cross-hatching on the plan below, be discontinued and sold.

Notwithstanding the said discontinuance Glen Eira City Council and Melbourne Water Corporation (South-East Water Ltd) shall continue to have and possess the right power or interest in connection with any sewers drains or pipes under control of those authorities in or over the land shown by cross-hatching on the plan below.

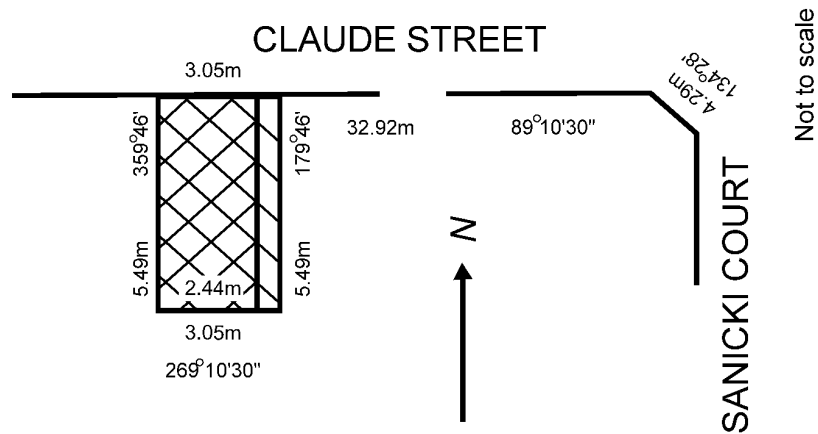

ANDREW NEWTON  
Chief Executive Officer

MOIRA SHIRE COUNCIL  
Road Discontinuance and  
Declaration of Public Highway

At its meeting on 8 September 2003 and acting under Section 204(1) and Clause 3 of Schedule 10 of the **Local Government Act 1989** ("Act") Moira Shire Council resolved to:

- discontinue the part of a road known as Orr Street, Yarrowonga ("Road") which is shown cross-hatched on the plan below;
- declare the part of the Road which is shown hatched on the plan below to be a public highway for the purposes of the Act.

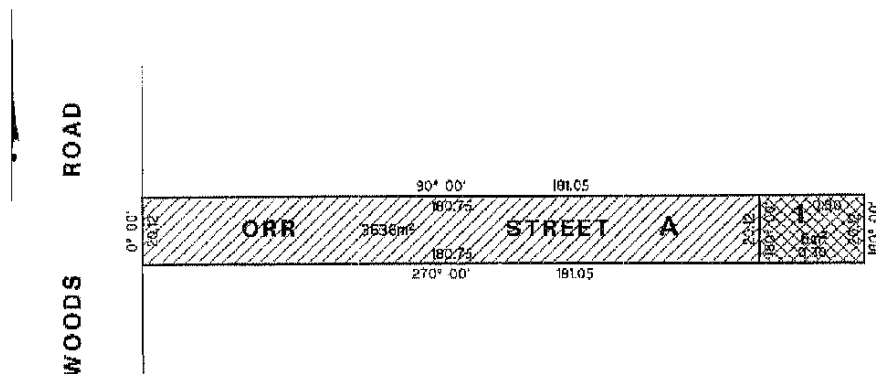

GAVIN CATOR  
Chief Executive Officer



GENERAL AMENDMENT  
LOCAL LAW 2003

Notice is hereby given that at its Ordinary Meeting of 29 September 2003, Melton Shire Council made General Amendment Local Law 2003.

The purpose of the General Amendment Local Law 2003 is to amend Local Law No. 1 by inserting Clause 527 titled "Noise from Vehicle Sound Equipment". The purport of the General Amendment Local Law 2003 is to improve the amenity in residential areas within the municipality where noise emanating from motor vehicle sound equipment is a public nuisance.

The Amendment (Meeting Procedure) Local Law 2003 came into operation on 29 September 2003.

A copy of the General Amendment Local Law 2003 can be inspected at the Civic Centre, 232 High Street, Melton, during business hours.

NEVILLE SMITH  
Chief Executive

TOWONG SHIRE COUNCIL

Road Naming

Towong Shire Council, pursuant to Section 206 and Schedule 10, Clause 5(1)(a) and Section 223 of the **Local Government Act 1989**, and following the Ordinary Meetings held on 3 June 2002, 5 August 2002, and 4 November 2002, hereby gives notice of the naming or renaming of the following roads within the Towong Shire.

BETHANGA TOWNSHIP

- Rename Henry Street to be a part of Jobling Street.
- Rename part Hewitt Street to be part of Beardmore Street.
- Name road with access from Wise Street to Rosella Court.
- Name road with access from Martins Road (located approximately 450m northeast of the Martins Road/Hollow Street intersection) to Coysh Lane.

BETHANGA LOCALITY

- Rename part Bethanga Road, Bethanga Park Road, and part Bethanga—Tallangatta Road to Lake Road (i.e. the road which is closest to Lake Hume between the townships of Bellbridge and Old Tallangatta).
- Rename part Bethanga Road to Bethanga Bay Road (i.e. the road leading southwest from the Bethanga township to the intersection with the newly named Lake Road at Bethanga Bay, Lake Hume).
- Rename part Bethanga—Tallangatta Road to Springdale Road (i.e. the road leading southeast then south from Bethanga past the Bethanga golfcourse to the intersection with the newly named Lake Road at Lake Hume).
- Bethanga—Talgarno Road to Talgarno Gap Road.

CUDGEWA TOWNSHIP AND LOCALITY

- Rename the Cudgewa—Tintaldra Road to Cudgewa Valley Road.
- Rename the length of the Cudgewa—Tintaldra Road in the township to Main Street.
- Rename the Stoney Creek Road to Bluff Falls Road.

TALGARNO, GRANYA & BULLIOH LOCALITIES

- Rename the Talgarno Road to be a part of the Murray River Road. (This part of the road lies east the township of Bellbridge and west of the (existing) Murray River Road/Talgarno Road intersection at Cottontree Creek bridge, Granya.)
- Rename part of the Murray River Road to Granya Road. This part of the road lies south of the (existing) Murray River Road/Talgarno Road intersection at Cottontree Creek bridge, Granya and north of the Murray Valley Highway intersection at Bullioh.

TOWONG LOCALITY

- Rename part of the Upper Murray Road to Towong Hill Road.

WALWA AND SHELLEY LOCALITIES

- Rename the road between Cudgewa Bluff Road and Sandy Creek Road (located approximately 6 km to the south of the township of Walwa) to Clarke Road.
- Rename the Shelley—Walwa Road to Shelley Road.

Further information can be obtained from Mr Bruce Braines, Asset Engineer on (02) 6071 5100, and associated maps can be viewed at the Towong Shire offices at 32 Towong Street, Tallangatta.

RAY PARK  
Chief Executive

**Planning and Environment Act 1987**

CARDINIA PLANNING SCHEME

Notice of Amendment

Amendment C53

The Cardinia Shire Council has prepared Amendment C53 to the Cardinia Planning Scheme.

The Amendment affects land described as Lot 2005 on Plan of Subdivision PS447415B which adjoins the Princes Highway, Lakeside Link and Flinders Chase in Pakenham.

The Amendment proposes to rezone the land from a Comprehensive Development Zone to a Public Use 7 Zone (other public uses) to allow the use and development of the land for a police and emergency services complex.

The Amendment can be inspected at: Cardinia Shire Council, Municipal Office, Henty Way, Pakenham; Department of Sustainability and Environment, Planning Information Centre, Upper Plaza, Nauru House, 80 Collins Street, Melbourne; and Department of Sustainability and Environment, South East Metropolitan Regional Office, 12 Lakeside Drive, East Burwood.

Any person who is affected by the Amendment may make a submission in writing about the Amendment. Copies of submissions received will be made available for public inspection as required by the **Planning and Environment Act 1987**. Submissions must be sent to: Phillip Walton, Manager Strategic Planning, Cardinia Shire Council, PO Box 7, Pakenham 3810 by 17 November 2003.

**Planning and Environment Act 1987**

DAREBIN PLANNING SCHEME

Notice of Amendment

Amendment C51

The City of Darebin has prepared an amendment to the Darebin Planning Scheme.

The Amendment affects land at:  
Lancaster Gate

The Amendment affects part of land currently known as Lancaster Gate formerly known as the Larundel Psychiatric Hospital. The land is currently in the ownership of VicUrban and is located east of Plenty Road and north of La Trobe University, in Bundoora.

Other Sites

The Amendment also affects land at:

- 1101 Plenty Road, Bundoora;
- 137 Fyffe Street, Thornbury;
- 8A Urquhart Street, Northcote;
- 127 Station Street, Fairfield;
- 8B Eunson Avenue, Northcote; and
- Central Creek Development — land located between Central Creek, Mahoneys Road and Bartrop Street, Reservoir.

The Amendment proposes to change the planning scheme by:  
Lancaster Gate

The Amendment proposes to rezone the land within stages 1 to 4 of the Lancaster Gate development (known as the residential precinct) currently zoned Mixed Use to Residential 1.

The Amendment introduces vegetation protection controls into the Darebin Planning Scheme on the subject site. The controls will require planning permission for the removal or lopping of identified significant trees.

Amendment C51 also includes a number of “housekeeping” matters to update and ensure the accuracy of the Planning Scheme.

The Amendment can be inspected at: Darebin City Council, Strategic Planning Unit, Level 1, 274 Gower Street, Preston, Vic. 3072; Department of Sustainability and Environment, Planning Information Centre, Upper Plaza, Nauru House, 80 Collins Street, Melbourne, Vic. 3000; and the Darebin Website [www.darebin.vic.gov.au/cccc.html](http://www.darebin.vic.gov.au/cccc.html)

Any person or agency who may be effected by the Amendment can make a submission to the City of Darebin. Submissions about the Amendment must be sent to Kim Godi, City of Darebin, PO Box 91, Preston 3072, by the close of business on 17 November 2003.

Please contact Kim Godi on 9230 4461 or email at [kgodi@darebin.vic.gov.au](mailto:kgodi@darebin.vic.gov.au) with any questions.

Please be aware that any objections/submissions received are publicly available to any person for the purpose of consideration as part of the planning process.

PAUL DICKIE  
Manager Urban Development

### **Planning and Environment Act 1987**

#### MONASH PLANNING SCHEME

##### Notice of Amendment

##### Amendment C50

The City of Monash has prepared Amendment C50 to the Monash Planning Scheme.

The Amendment applies to the Oakleigh Primary School, 20 Warrigal Road, Oakleigh and proposes to address an anomaly on the Planning Scheme maps.

The Amendment proposes to rezone the eastern part of the Oakleigh Primary School from Public Park and Recreation to Public Use Zone (2) — Education.

The Amendment and associated documentation can be inspected free of charge, during office hours at the Department of Sustainability and Environment, Planning Information Centre, Upper Plaza, Nauru House, 80 Collins Street, Melbourne and at the offices of the Monash City Council, 293 Springvale Road, Glen Waverley.

Submissions about the Amendment should quote Amendment No. C50 and be sent to the City of Monash, PO Box 1, Glen Waverley 3150 by 17 November 2003.

DAVID CONRAN  
Chief Executive Officer

### **Planning and Environment Act 1987**

#### MONASH PLANNING SCHEME

##### Notice of Amendment

##### Amendment C36

The City of Monash has prepared Amendment C36 to the Monash Planning Scheme.

The Amendment proposes a “cash in lieu” car parking contribution for changes of use and/or new development generating additional car parking demand at Glen Waverley and will:

- incorporate and apply the Glen Waverley Activity Centre Parking Precinct Plan into the Planning Scheme;
- incorporate and apply the Glen Waverley Activity Centre Parking Development Contributions Plan and a Development Contributions Plan Overlay and the associated Schedule to the land affected by the Amendment into the Planning Scheme;
- amend the schedule to the Business 1 Zone by making restaurant a “use” requiring a permit;
- make consequential changes to the Municipal Strategic Statement concerning the use of a Parking Precinct Plan and a Development Contributions Plan in the Glen Waverley Activity Centre; and
- alter the Planning Scheme maps to apply a Development Contributions Plan Overlay to the relevant part of the Glen Waverley Activity Centre.

The Amendment can be inspected free of charge, during office hours at the Department of Sustainability and Environment, Planning Information Centre, Upper Plaza, Nauru House, 80 Collins Street, Melbourne and at the offices of the Monash City Council, 293 Springvale Road, Glen Waverley.

Submissions about the Amendment must be sent to the City of Monash, PO Box 1, Glen Waverley 3150 by 20 November 2003.

DAVID CONRAN  
Chief Executive Officer

### **Planning and Environment Act 1987**

#### MORELAND PLANNING SCHEME

##### Notice of Preparation of Amendment

##### Amendment C45

The Moreland City Council has prepared Amendment C45 to the Moreland Planning Scheme.

The land affected by the Amendment is Rear 1 Sheffield Street, Coburg, Certificate of Title Volume 8856, Folio 283.

The Amendment proposes to rezone the land from the Business 3 Zone to the Business 2 Zone.

You may inspect the Amendment, any documents that support the Amendment and the

explanatory report about the Amendment at the following locations: at the office of the planning authority, Moreland City Council, Customer Service Centre, 90 Bell Street, Coburg; and at the Department of Sustainability and Environment, Planning Information Centre, Upper Plaza, Nauru House, 80 Collins Street, Melbourne.

This can be done during office hours and is free of charge.

Any person who may be affected by the Amendment may make a submission to the planning authority.

The closing date for submissions is 17 November 2003. A submission must be sent to: Moreland City Council, Strategic Planning Unit, Submission to Amendment C45, Locked Bag 10, Moreland 3058.

ROGER COLLINS  
Director City Development

Creditors, next-of-kin and others having claims against the estate of any of the undermentioned deceased persons are required to send particulars of their claims to State Trustees Limited, ABN 68 064 593 148, 168 Exhibition Street, Melbourne, Victoria 3000, the personal representative, on or before 18 December 2003 after which date State Trustees Limited may convey or distribute the assets having regard only to the claims of which State Trustees Limited then has notice.

AURISH, Mabel Alice, also known as Mabel Alice Aurisch, late of Strathalan Nursing Home, Erskine Road, MacLeod, pensioner and who died on 9 September 2003.

COLLINS, Lynette Anne, late of 127 Heatherhill Road, Frankston, and who died on 20 August 2003.

ENNIS, Thomas Edward James, late of 17 Cole Street, St Leonards, Victoria 3223, and who died on 24 June 2003.

FREITAG, Frederick Charles, late of 1/45 Fawkner Street, South Yarra, Victoria 3141, accountant and who died on 24 May 2003.

McGEEHAN, Mabel Miriam, formerly of Smith Street, Myrtleford, but late of Barwidgee Lodge, O'Donnell Avenue, Myrtleford, retired and who died on 21 July 2003.

PILLAR, Laurence, formerly of Unit 18, Outlook Gardens Retirement Village, 237 Outlook Drive, Dandenong North, but late of Room 9, Outlook Gardens Hostel, 504 Police Road, Dandenong North, retired and who died on 3 August 2003.

PURCELL, Philomena, late of Flat 6, 130 Spensley Street, Clifton Hill, Victoria, retired laboratory worker and who died on 9 June 2003.

SCICLUNA, Carmelo, also known as Charles Scicluna, formerly of 98 Westall Road, Springvale, but late of Springvale Private Nursing Home, 360 Springvale Road, Springvale, pensioner and who died on 13 July 2003.

STORCK, Dorothy, late of 23 Victoria Road, Northcote, Victoria 3070, pensioner and who died on 22 September 2003.

WHITE, Donald James, late of 88 McLeod Street, Coleraine, Victoria 3315 and who died on 7 May 2003.

Dated at Melbourne, 9 October 2003

LAURIE TAYLOR  
Estate Manager  
State Trustees Limited

#### EXEMPTION

Application No. A368 of 2003

The Victorian Civil and Administrative Tribunal has considered an application, pursuant to Section 83 of the **Equal Opportunity Act 1995**, by Women's Health Goulburn North East for exemption from Sections 13, 59, 60, 100 and 195 of that Act. The application for exemption is to enable the applicant to engage in the exempt conduct.

In this exemption "exempt conduct" means —

- (a) advertising for and employing women only to work in the applicant's health service;
- (b) advertising for and employing women of a specified race or ethnic origin, or whose first language is a specified language other than English, to work in the health service on specific projects targeted at groups of women of that race or ethnic origin or whose first language is that language;
- (c) to restrict individual membership of the service to women only;

(d) to require that organisations that are members of the service be represented at meetings (whether they come to attend, speak or vote) by women only.

The Tribunal notes the applicant has previously been granted an Exemption, Number A253 of 2000 which expired on 26 July 2003.

Upon reading the material submitted in support of the application by Ms. Jean Farrington, Executive Director, the Tribunal is satisfied that it is appropriate to grant an exemption from Sections 13, 59, 60, 100 and 195 of the Act to enable the applicant to engage in the exempt conduct.

The Tribunal hereby grants an exemption to the applicant from the operation of Sections 13, 59, 60, 100 and 195 of the **Equal Opportunity Act 1995** to enable the applicant to engage in the exempt conduct.

This exemption is to remain in force from the day on which notice of the exemption is published in the Government Gazette until 16 July 2006.

Dated 9 October 2003.

Mrs M. URQUHART  
Deputy President

#### **Adoption Act 1984**

##### SECTIONS 21, 22 AND 26

##### Application for Approval as an Adoption Agency

Under the provisions of Section 10(2) of the **Community Services Act 1970** I have been assigned the functions and powers of the Secretary of Department of Human Services under Sections 21, 22 and 26 of the **Adoption Act 1984**.

The following welfare organisations have applied for approval as an adoption agency:

Anglicare Gippsland, 65 Church Street, Morwell 3840. Principal officer: Dennis Minster; Anglicare Western, 41 Somerville Road, Yarraville 3013. Principal officer: Sylvia Lemke; Uniting Care Connections, 274 High Street, Windsor 3181. Principal officer: Jane Broadhead; Child and Family Services Ballarat Inc., 115 Lydiard Street North, Ballarat 3350. Principal officer: Chris Delahunty; Centacare Catholic Family Services, 576 Victoria Parade,

East Melbourne 3002. Principal officer: Vicky Shannon; and LDS Social Services, First Floor, 1027–1029 High Street, Armadale 3143. Principal officer: Peter L. Howell.

Dated 9 October 2003

GILL CALLISTER  
Director  
Child Protection  
and Juvenile Justice

#### **Agricultural and Veterinary Chemicals (Control of Use) Act 1992**

##### APPOINTMENT OF AN AUTHORISED OFFICER UNDER SECTION 53

I, Peter Bailey, Director Quality Assurance, acting in accordance with Section 53 of the **Agricultural and Veterinary Chemicals (Control of Use) Act 1992**, hereby appoint Michael Hansford being a person who holds an office in the Public Service to be an authorised officer for the purpose of providing chemical information as specified under Section 45(1) of the **Agricultural and Veterinary Chemicals (Control of Use) Act 1992**.

Dated 13 October 2003

PETER J. BAILEY  
Director Quality Assurance  
Department of Primary Industries

#### **Essential Services Commission Act 2001**

##### SECTION 35(2)

##### Notice of Determination

The Essential Services Commission (the Commission) gives notice under section 35(2) of the **Essential Services Commission Act 2001** of the making of a Determination under section 34 of that Act.

On 15 November 2001, the Essential Services Commission (the Commission) issued the Charges for Prescribed Grain Handling Services: Amended Price Determination (the Amended Price Determination), pursuant to section 15 of the **Grain Handling and Storage Act 1995** and section 33 of the **Essential Services Commission Act 2001**.

On 28 August 2003, the Grain Handling and Storage (Amendment) Bill 2003 ("the Bill") was introduced in the Parliament of Victoria, which



provides for the Commission's powers to regulate prices of prescribed services at the export grain handling terminals at the ports of Portland and Geelong to cease, except with the approval of the relevant Minister following an inquiry by the Commission.

On 3 October 2003 the Commission made the following Determination:

- (i) The amended Price Determination will be revoked pursuant to subsection 35(6) of the **Essential Services Commission Act 2001** on the date that the **Grain Handling and Storage (Amendment) Act 2003** comes into operation.
- (ii) For clarification, if the Bill is not enacted, the Amended Price Determination will continue in force until the Commission determines otherwise.

A non-confidential copy of the Determination will be available for inspection from the Commission's website at [www.esc.vic.gov.au](http://www.esc.vic.gov.au) or at the Essential Services Commission during business hours by contacting Julie Grubnau, Level 2, 35 Spring Street, Melbourne, Victoria, 3000. Phone: (03) 9651 0244. [julie.grubnau@esc.vic.gov.au](mailto:julie.grubnau@esc.vic.gov.au)

#### **Health Services Act 1988**

##### DECLARATION OF APPROVED QUALITY ASSURANCE BODY

I declare the Clinical Risk Management Program Reference Panel established by South Gippsland Division of General Practice is an approved quality assurance body under Section 139 for the purposes of part 7 of the **Health Services Act 1988**.

Dated 30 September 2003

BRONWYN PIKE  
Minister for Health

#### **Mineral Resources Development Act 1990**

##### EXEMPTION FROM EXPLORATION LICENCE OR MINING LICENCE

I, Richard Aldous, Executive Director Minerals and Petroleum, pursuant to Section 7 of the **Mineral Resources Development Act 1990** and under delegation by the Minister for Energy Industries and Resources —

1. HEREBY EXEMPT all that Crown land situated within the boundaries of exploration licence applications 4767, 4768, 4769, 4770 & 4771 that have been excised from the applications, from being subject to an exploration licence or mining licence.
2. Subject to paragraph 3, this exemption applies until the expiration of 2 years after the grant of the licence (if the licence is granted), or until the expiration of 28 days after the application lapses or is withdrawn or refused.
3. This exemption is REVOKED in respect of any land that ceases to lie within the boundaries of the application or licence, at the expiration of 28 days after the said land ceases to lie within the boundaries of the application or licence.

Dated 14 October 2003

RICHARD ALDOUS  
Executive Director  
Minerals and Petroleum



### **Legal Practice Board**

#### ELECTION NOTICE

Election of one (1) Practitioner Member  
to the Legal Practice Board

In accordance with the Legal Practice (Board Elections) Regulations 1997, notice is hereby given that Peter Roderick Leslie Smith has been elected unopposed as the practitioner member to the Legal Practice Board.

PETER HEARD  
Returning Officer

#### **Nurses Act 1993**

Re: STEVEN HENRY WRIGHT  
IDENTIFICATION NUMBER 1505794  
REGISTERED IN DIVISIONS 2 AND 3

On 10 October 2003, the Victorian Civil and Administrative Tribunal ordered the determination made by a panel of the Nurses Board of Victoria on 30 April 2003, be set aside and substituted for it the following determination pursuant to Section 48(2) of the **Nurses Act 1993**.

## Orders:

1. Pursuant to Section 48(2)(g) of the Act, the nurse's registration be suspended for 3 months, commencing on 7 May 2003.
2. After the period of suspension pursuant to paragraph 1 of this determination, the following conditions, limitations or restrictions shall be imposed on the nurse's registration pursuant to Section 48(2)(e) of the Act:
  - (a) the nurse's practice must be supervised for 12 months;
  - (b) within 13 months of the commencement of supervision, the nurse must provide the Board with a report of the period of his supervised practice.
3. If the report of supervised practice pursuant to the conditions imposed under sub-paragraph 2(b) of this determination is satisfactory to the Board, then the conditions imposed by sub-paragraph 2(a)–(b) must be removed at the next meeting of the Board after the report is received.
4. Pursuant to Section 48(2)(d) of the Act, the nurse is required to undergo further education in professional boundaries, the unit or module to be approved in writing by the Board before tuition commences, and to be satisfactorily completed within 12 months, or a later date with the Board's approval, of the nurse's registration being restored after the suspension pursuant to paragraph 1 of this determination.

LOUISE MILNE-ROCH  
Chief Executive Officer

**Retirement Villages Act 1986**

## SECTION 39

## Cancellation of Retirement Village Notice

I hereby declare that the Retirement Village Notice No. T273744U pursuant to section 9 of the **Retirement Villages Act 1986**, registered on 26 August 1994 on Certificate of Title Volume 10040 Folio 633 under the **Transfer of Land Act 1958**, is cancelled.

Dated 2 October 2003

Dr DAVID COUSINS  
Director Consumer Affairs Victoria

**Transport Act 1983**TOW TRUCK DIRECTORATE  
OF VICTORIA

## Tow Truck Application

Notice is hereby given that the following application will be considered by the Licensing Authority after 19 November 2003.

Notice of any objection to the granting of an application should be forwarded to reach the Director, Tow Truck Directorate of Victoria, Level 6, 14–20 Blackwood Street, North Melbourne (PO Box 666, North Melbourne 3051) not later than 13 November 2003.

It will not be necessary for interested parties to appear on the date specified, unless advised in writing.

A. Fassoulis. Application for variation of conditions of tow truck licence number TOW676 which authorises the licensed vehicle to be managed, controlled and operated from a depot situated at 340 Nicholson Street, Fitzroy to change the depot address to 53 Church Street, Abbotsford.

Dated 16 October 2003

STEVE STANKO  
Director

**Water Act 1989**

## SECTION 44

## Amendment of Entitlement by Order

I, John Thwaites, under the provisions of the **Water Act 1989**, amend the Bulk Entitlement (Maribyrnong—Southern Rural Water) Conversion Order 2000 by replacing paragraph 12(1)(b) with—

- (b) a minimum flow at the Gisborne gauging station at an instantaneous rate of—
  - (i) at least 1 ML/day if the flow at the Sunbury gauging station is greater than 1 ML/day; or
  - (ii) 3 ML/day if the flow at the Sunbury gauging station is less than 1 ML/day; and

This amendment applies until midnight 30 June 2004 after which date the original paragraph 12(1)(b) applies.

The Minister or his delegate may revoke this amendment by advising Southern Rural Water

in writing, if at any time, the Minister or his delegate is of the opinion there is a strong risk that the environmental condition of Jacksons Creek will deteriorate to an unacceptable extent as a result of this amendment.

Dated 29 September 2003

JOHN THWAITES,  
Minister administering the  
**Water Act 1989**

**Education Act 1958**

NOTICE OF MAKING OF ORDER UNDER SECTION 13 AND ADMINISTRATIVE  
ARRANGEMENTS ORDER (NO. 180) 2002

An Order of the Minister for Education Services was made on 3 October 2003 under section 13(1) of the **Education Act 1958** and Administrative Arrangements Order (No. 180) 2002 constituting a school council for a State school at Alkara Avenue, Lara, proposed to be called Lara Secondary College.

JACINTA ALLAN  
Minister for Education Services

**Education Act 1958**

NOTICE OF MAKING OF ORDERS UNDER SECTION 13 AND ADMINISTRATIVE  
ARRANGEMENTS ORDER (No. 180) 2002

Three Orders of the Minister for Education Services were made on 3 October 2003 under section 13(4) and 13(11) of the **Education Act 1958** and Administrative Arrangements Order (No. 180) 2002 amending the constituting Orders of Glenorchy Primary School Council, Learmonth Primary School Council and Trawalla Primary School Council in respect of the memberships of the school councils.

JACINTA ALLAN  
Minister for Education Services

**Education Act 1958**

NOTICE OF MAKING OF ORDERS UNDER SECTION 13 AND  
ADMINISTRATIVE ARRANGEMENTS ORDER (No. 180) 2002

Two Orders of the Minister for Education Services were made on 3 October 2003 pursuant to sections 13(4) and 13(11) of the **Education Act 1958** and Administrative Arrangements Order (No. 180) 2002 each amending the constituting Order of a school council to change its name. The changes are as follows:

Old name	New name
Council of the State school proposed to be called Doncaster Park/Manningham Primary School	Council of the State school called Manningham Park Primary School
Council of the State school proposed to be called Meadowbank Primary School	Council of the State school called Meadowbank Primary School

JACINTA ALLAN  
Minister for Education Services

**Geographic Place Names Act 1998****CORRIGENDUM**

In the Victoria Government Gazette No. G41, 9 October 2003, page 2601, under Registration of Amendment of Geographic Names, the place name of Hill Crest should read Hillcrest and the place name of Homebush should be excluded.

Office of the Registrar of Geographic Names

c/- **LAND VICTORIA**,  
Level 15, Marland House,  
570 Bourke Street,  
Melbourne

JOHN E. TULLOCH  
Registrar of Geographic Names

**Geographic Place Names Act 1998****NOTICE OF REGISTRATION OF GEOGRAPHIC NAMES**

The Registrar of Geographic Names hereby gives notice of the registration of undermentioned place names.

<b>File No.</b>	<b>Place Name</b>	<b>Proposer &amp; Location</b>
LA/12/0055	Sugarloaf Creek	Mitchell Shire Council. As on version 4.2 of the plan showing the town and rural district names and boundaries within the municipality. Copies of this plan may be inspected at the municipal offices or at the office of the Registrar of Geographic Names.
LA/12/0067	Homebush (formerly known as Lower Homebush)	Pyrenees Shire Council. As on version 4.4 of the plan showing the town and rural district names and boundaries within the municipality. Copies of this plan may be inspected at the municipal offices or at the office of the Registrar of Geographic Names.
GPN 574	Roxburgh Park Primary School	Department of Education. Located in Almands Avenue, Roxburgh Park.

Office of the Registrar of Geographic Names

c/- **LAND VICTORIA**  
15th Floor,  
570 Bourke Street,  
Melbourne 3000

JOHN E. TULLOCH  
Registrar of Geographic Names

**Geographic Place Names Act 1998****REGISTRATION OF AMENDMENT OF GEOGRAPHIC NAMES**

The Registrar of Geographic Names hereby gives notice of the registration of amendment of the undermentioned place names.

File No.	Place Name	Proposer & Location
LA/12/0058	Balliang, Balliang East, Parwan.	Moorabool Shire Council. As on version 4.2 of the plan showing the town and rural district names and boundaries within the municipality. Copies of this plan may be inspected at the municipal offices or at the office of the Registrar of Geographic Names.
LA/12/0055	Glenaroua	Mitchell Shire Council. As on version 4.2 of the plan showing the town and rural district names and boundaries within the municipality. Copies of this plan may be inspected at the municipal offices or at the office of the Registrar of Geographic Names.

Office of the Registrar of Geographic Names

c/- **LAND VICTORIA**  
15th Floor,  
570 Bourke Street,  
Melbourne 3000

JOHN E. TULLOCH  
Registrar of Geographic Names

### Gas Safety Act 1997

#### Essential Services Commission Act 2001

#### MEMORANDUM OF UNDERSTANDING BETWEEN

#### THE ESSENTIAL SERVICES COMMISSION AND THE OFFICE OF GAS SAFETY

THIS MEMORANDUM is made on 30 September 2003

**PARTIES:** ESSENTIAL SERVICES COMMISSION (the "Commission")

and OFFICE OF GAS SAFETY (the "Office")

#### BACKGROUND:

- A. The Office is a prescribed agency for the purposes of the **Essential Services Commission Act 2001**.
- B. The parties have entered into this memorandum of understanding to provide for consultation between them and the integration and co-ordination of their regulatory and other activities, in accordance with sections 15 and 16 of the **Essential Services Commission Act 2001**.

#### OPERATIVE PROVISIONS:

##### 1. Definitions

In this memorandum, including the background:

"GS Act" means the **Gas Safety Act 1997** (Vic);

"ESC Act" means the **Essential Services Commission Act 2001** (Vic);

"prescribed agency" has the same meaning as in the ESC Act;

"regulated industry" has the same meaning as in the ESC Act.

**2. Objectives and purpose of this memorandum**

This memorandum seeks to:

- (a) ensure that the regulatory and decision making processes of the parties in relation to regulated industries are closely integrated and better informed;
- (b) avoid overlap or conflict between regulatory schemes (either existing or proposed) affecting regulated industries;
- (c) provide for sharing information between the parties in the context of their respective roles in relation to regulated industries;
- (d) promote the adoption of a best practice approach to regulation; and
- (e) assist in ensuring that the Commission is in a position to have regard to relevant gas safety legislation and regulatory practice in its decision making in relation to regulated industries.

**3. The role of the Commission**

3.1 The Commission currently has functions relating to the economic regulation of the electricity, gas, ports, grain handling, freight rail, taxi, hire car, tow truck, statutory insurance and water industries. Its specific functions are:

- (a) to perform such functions as are conferred by the ESC Act and the relevant legislation under which a regulated industry operates;
- (b) to advise the relevant Minister on matters relating to the economic regulation of regulated industries, including reliability issues;
- (c) when requested by the Minister to do so, to conduct an inquiry into any systemic reliability of supply issues related to a regulated industry or other essential service specified by the Minister in the request;
- (d) to conduct inquiries and report under the ESC Act on matters relating to regulated industries;
- (e) to make determinations in accordance with the ESC Act;
- (f) to make recommendations to the Minister as to whether an industry which provides an essential service should become a regulated industry or whether a regulated industry should continue to be a regulated industry;
- (g) to conduct public education programs for the purpose of promoting its objectives under the ESC Act and the relevant legislation and in relation to significant changes in the regulation of a regulated industry;
- (h) to advise the Minister in relation to any other matter referred to the Commission by the Minister; and
- (i) to administer the ESC Act.

3.2 The Commission's primary objective in performing those functions is to protect the long-term interests of Victorian consumers with regard to the price, quality and reliability of essential services. In seeking to achieve that primary objective, the Commission must have regard to the following facilitating objectives:

- (a) to facilitate efficiency in regulated industries and the incentive for efficient long-term investment;
- (b) to facilitate the financial viability of regulated industries;
- (c) to ensure that the misuse of monopoly or non-transitory market power is prevented;
- (d) to facilitate effective competition and promote competitive market conduct;
- (e) to ensure that regulatory decision making has regard to the relevant health, safety, environmental and social legislation applying to the regulated industry;

- (f) to ensure that users and consumers (including low-income or vulnerable customers) benefit from the gains from competition and efficiency; and
  - (g) to promote consistency in regulation between States and on a national basis.
- 3.3 The Commission must also perform its functions and exercise its powers in such a manner as the Commission considers best achieves any objectives specified in the relevant legislation under which a regulated industry operates.
- 4. The role of the Office**
- 4.1 The Office has broad powers in relation to gas safety and the safety of non-automotive use of liquefied petroleum gas (LPG) and other gaseous fuels.
- 4.2 The specific functions of the Office are set out in the GS Act and include:
- (a) the issue of guidelines specifying minimum safety standards for appliances, gas equipment, gas components, gas installations, gas related services and the conveyance, sale, supply, measurement, control and use of gas;
  - (b) the issue of guidelines in relation to the preparation of safety cases;
  - (c) monitoring compliance of appliances, gas equipment, gas components, gas installations, gas related services and the conveyance, sale, supply, measurement, control and use of gas with the specified safety standards;
  - (d) monitoring compliance of gas companies with accepted safety cases;
  - (e) the audit of accepted safety cases to determine the adequacy and effectiveness of those safety cases;
  - (f) administration of the prescribed minimum standards for energy efficiency of gas installations, appliances and components;
  - (g) inspection and testing of gas installations, appliances and components for compliance with the specified minimum standards for energy efficiency;
  - (h) investigation of events or incidents which have implications for gas safety;
  - (i) the provision of advisory and consultative services in relation to gas safety; and
  - (j) consultation with and advise industry and the community in relation to gas safety.
- 5 How the parties will consult**
- 5.1 Where relevant, the Commission will, as early as practicable, consult with the Office:
- (a) in the making of a determination;
  - (b) in the conduct of an inquiry or investigation, after first consulting with the Minister; and
  - (c) in preparing and reviewing the Commission's Charter of Consultation and Regulatory Practice.
- 5.2 The Office will, if requested in writing by the Commission to do so, consult with the Commission:
- (a) in relation to any matter specified by the Commission which is relevant to the Commission's objectives or functions; and
  - (b) in respect of a matter specified by the Commission which may impact on a regulated industry.
- 5.3 Each party having regard to their respective roles in relation to each regulated industry will:
- (a) consult with and involve the other in the performance of any function that has or is likely to have material implications for the other<sup>1</sup>;
  - (b) ensure that such consultation occurs as early as practicable in the parties' regulatory, advisory or decision making processes;
- (c) on request, provide the other with timely advice on regulatory matters for which it is responsible;
- 
1. For example, the Commission proposes to give the Office the opportunity to sit on the Commission's working groups in conducting major reviews or inquiries.

- (d) provide the other with timely relevant information on industries or industry issues for which both parties have some responsibility;
- (e) promptly inform the other of any material changes to its role or to the regulatory arrangements it administers;
- (f) exchange details of annual work programs to the extent that they are relevant to the role of the other;
- (g) provide the other with advance notice of its intention to undertake a major review or activity that will or may have material implications for the other;
- (h) identify opportunities to co-ordinate strategic planning and undertake knowledge sharing initiatives to optimise material understanding of roles and strategic directions;
- (i) identify relevant project officers to allow for the co-ordination of particular regulatory projects; and
- (j) publish this memorandum on its website.

**6. How the parties will manage their relationship and resolve disputes**

- 6.1 Each party will ensure that, at all times while this memorandum is in force, one of its staff members is designated and known to the other as its contact officer for the purposes of this memorandum.
- 6.2 At the date of this memorandum, the contact officer for the Commission is Mr Nicholas Rizos, and the contact officer for the Office is Mr Mike Ebdon. Each party will give notice of any change to its contact officer to the other, promptly after the change is made.
- 6.3 Each party will ensure that its contact officer:
- (a) makes him/herself (or an alternate) available at all relevant times to address any questions, concerns or disputes arising out of the operation of this memorandum which are raised by either party;
  - (b) instigates periodic (and in any event not less than three yearly) reviews of this memorandum directed, in particular, to the potential for improvement in its terms or operation and to the effect (if any) of regulatory change on its terms, operation or utility; and
  - (c) arranges (in conjunction with the other's contact officer) such meetings of appropriate staff of the parties as and when necessary or desirable to facilitate the efficient and effective operation of this memorandum and including, in any event, a meeting of the Chairperson of the Commission and Director of Gas Safety no less frequently than annually.
- 6.4 If there is a dispute between the parties as to the terms or operation of this memorandum, each party will ensure that its contact officer endeavours in good faith to resolve that dispute with the other's contact officer. If, however, a contact officer gives notice to the other party's contact officer of the view that the dispute is unlikely to be resolved by discussions between the contact officers, then each party's contact officer must promptly:
- (a) brief the party's Chairperson of the Commission or Director of Gas Safety (or a nominee of the party's Chairperson or Director) of details of the relevant dispute; and
  - (b) arrange with the other's contact officer for a meeting of the Chairperson of the Commission and Director of Gas Safety (or their respective nominees), with the objective of settling the dispute amicably.



**7. Use and disclosure of information**

- 7.1 The capacity of a party to use or disclose information, or take information into account, is or may be (depending on the nature or source of the information) restricted by law.
- 7.2 If a party discloses information to the other party under this memorandum, the disclosing party may place restrictions on the recipient's use or disclosure of that information, being restrictions it believes in good faith are necessary for compliance with binding restrictions on disclosure. A party receiving information will observe any such restriction noting, however, that this requirement does not limit:
- (a) any other legal obligation of a party relating to the disclosure or use of information; and
  - (b) any right of a party concerning information obtained otherwise than under this memorandum.

EXECUTED AS A MEMORANDUM BY:

THE COMMON SEAL of the ESSENTIAL )  
 SERVICES COMMISSION was affixed )  
 pursuant to the authority of the Commission )

JOHN C. TAMBLYN  
 Chairperson

THE COMMON SEAL of the OFFICE OF )  
 GAS SAFETY is duly affixed by the Director )  
 on 30 September 2003 )

KENNETH A. GARDNER  
 Director of Gas Safety

**Gas Industry Act 2001**

NOTICE OF AMENDMENT UNDER SECTION 52(6)  
 Victorian Gas Industry Market and System Operation Rules  
 ("MSO Rules")

Pursuant to and in accordance with clause 52(6) of the **Gas Industry Act 2001** VENCORP has resolved to amend the MSO Rules as follows, effective as of 16 October 2003.

Clause 3.6.18 is amended by inserting the words "provided in accordance with clause 3.6.14" at the end of sub-clause 3.6.18(a)(2).

Clause 3.6.18 is amended by deleting clause 3.6.18(b) and substituting the following:

- "(b) Subject to clause 3.6.18(d), if a dispute arises between a *Market Participant* and *VENCORP* during the period between the issue of a *final statement* and the issue of a *revised statement* in accordance with clause 3.6.19(c) concerning either:
- (1) *the settlement amount* stated in a *final statement* provided under clause 3.6.15 to be payable by or to it; or
  - (2) the supporting data provided in accordance with clause 3.6.15, they must each use reasonable endeavours to resolve the dispute within 113 *business days* after the end of the *billing period*.
- (ba) Subject to clauses 3.6.18(b) and 3.6.18(d), disputes in respect of:
- (1) *the settlement amount* stated in a *revised statement* provided under clause 3.6.19 to be payable by or to it; or
  - (2) the supporting data provided in accordance with clause 3.6.19, must be raised within twelve (12) months of the *revised statement* issue date."

Clause 3.6.18 is amended by deleting the reference to “3.6.18” and substituting the reference “3.6.18(ba)” in clause 3.6.18(c).

Clauses 3.6.19(a) and 3.6.19(b) are deleted.

Clause 3.6.19 is amended by deleting clauses 3.6.19(ca) and 3.6.19(cb) and substituting the following:

- “(ca) If, within 12 months of the issue of a *revised statement* under clause 3.6.19(c), *VENCorp* becomes aware of an error in an amount stated in that *revised statement* and in *VENCorp*'s reasonable opinion a *Participant* would be materially affected if a revision to the *revised statement* was not made to correct the error, then *VENCorp* must:
- (1) advise each *Market Participant* likely to be materially affected by the error within five (5) *business days* of *VENCorp* deciding the error is material, and
  - (2) as soon as practicable issue *revised statements* for the relevant *billing period* in accordance with clause 3.6.19(d).
- (cb) If an amount in a *revised statement* issued under clauses 3.6.19(c) or 3.6.19(ca) has been the subject of a dispute and the dispute has been resolved in any way which causes the amount payable to differ from the amount payable in the disputed *revised statement* then *VENCorp* must issue to each *Market Participant* affected by the resolution of the dispute a *revised statement* in accordance with clause 3.6.19(d).”

Clause 3.6.19 is amended by deleting the reference to “3.6.19(a)” and substituting the reference “3.6.19(d)” in sub-clause 3.6.19(d)(2).

Clause 3.6.19 is amended by inserting after clause 3.6.19(d) the following new clause:

- “(e) The statements issued under this clause 3.6.19 must include supporting data for all amounts payable which must be sufficient to enable each *Market Participant* to audit the calculation of the amount payable by or to that *Market Participant*.”

Clause 7.2.5 is amended by deleting clause 7.2.5(c) and substituting the following:

- “(c) the dispute must be referred to the *Adviser* in accordance with clause 7.2.3(a), or to the *Regulator* under clause 7.2.1(c), within twelve months of the issue date of the *settlement statement* or other invoice to which the disputed payment relates;”

Clause 7.2.5 is amended by inserting the words “or other invoice” after the words “*statement*” in clauses 7.2.5(d) and 7.2.5(e).

Clause 7.2.6 is amended by deleting the words “*settlement statement* issued under clause 3.6.15” and substituting the words “*revised statement* issued under clauses 3.6.19(b) or 3.6.19(c)”.

Clause 7.2.6 is amended by deleting the words “revised *settlement*” in clause 7.2.6(a) and substituting the word “*revised*”.

Clause 7.2.6 is amended by deleting the words “*settlement statement*” and substituting the words “*revised statement*” in clause 7.2.6(a).

MATT ZEMA  
Chief Executive Officer  
VENCorp

---

### Private Agents Act 1966

#### NOTICE OF RECEIPT OF APPLICATIONS FOR LICENCES UNDER THE PROVISIONS OF THE PRIVATE AGENTS ACT 1966

I, the undersigned, being the Deputy Registrar of the Magistrates' Court at Ballarat hereby give notice that applications, as under, have been lodged for hearing by the said Court on the date specified.

Any person desiring to object to any of such applications must—

- (a) lodge with me a notice in the prescribed form of his objection and of the grounds thereof;
- (b) cause a copy of such notice to be served personally or by post upon the applicant at least three days before the hearing of the application; and
- (c) send or deliver
  - (i) where the objection is not made by the officer in charge of the police district in which the Court is situated—a copy of the notice to such officer; and
  - (ii) where the objection is not made by the Registrar or Deputy Registrar—a copy to the Registrar.

<i>Full Name of Applicant or in the case of a Firm or Corporation, of the Nominee</i>	<i>Place of Abode of Applicant or Nominee</i>	<i>Name of Firm or Corporation</i>	<i>Address for Registration</i>	<i>Type of Licence</i>	<i>Date of Hearing of Application</i>
Scott Cameron Syddall	4 Royale Street, Delacombe 3356	Webb Ervin Debt Collection Services	24 Sturt Street, Ballarat	Commercial agent	27/10/03
Scott Cameron Syddall	4 Royale Street, Delacombe 3356		24 Sturt Street, Ballarat	Commercial sub-agent	27/10/03

Dated at Ballarat 6 October 2003

STEPHEN J. KIRKPATRICK  
Deputy Registrar  
of the Magistrates' Court of Victoria  
Court House, Ballarat

### **Private Agents Act 1966**

#### **NOTICE OF RECEIPT OF APPLICATIONS FOR LICENCES UNDER THE PROVISIONS OF THE PRIVATE AGENTS ACT 1966**

I, the undersigned, being the Registrar of the Magistrates' Court at Melbourne hereby give notice that applications, as under, have been lodged for hearing by the said Court on the date specified.

Any person desiring to object to any of such applications must—

- (a) lodge with me a notice in the prescribed form of his objection and of the grounds thereof;
- (b) cause a copy of such notice to be served personally or by post upon the applicant at least three days before the hearing of the applications; and
- (c) send or deliver
  - (i) where the objection is not made by the officer in charge of the police district in which the Court is situated—a copy of the notice to such officer; and
  - (ii) where the objection is not made by the Registrar or Deputy Registrar—a copy to the Registrar.

<i>Full name of Applicant or in the case of a Firm or Corporation, of the Nominee</i>	<i>Place of Abode of Applicant or Nominee</i>	<i>Name of Firm or Corporation</i>	<i>Address for Registration</i>	<i>Type of Licence</i>
Gustavo Perez	3/175 Bluff Road, Sandringham Victoria	Gustavo Perez	3/175 Bluff Road, Sandringham Victoria	Commercial agents licence
Simon C. Whittle	179 Hawke Street, West Melbourne 3003	Advanced Credit Management	Level 5, 455 Bourke Street, Melbourne, Vic. 3000	Commercial sub-agents licence
Angela Ucchino	7 Adam Court, Viewbank 3084	Australian Receivables Limited	Level 13, 45 William Street, Melbourne, Vic. 3000	Commercial sub-agents licence
Wanda Mackenzie Taylor	1/2 Rimmer Street, Mentone	Repcol Limited	Suite 4-5, Level 5, Illoura Plaza, 424 St Kilda Road, Melbourne, 3004	Commercial sub-agents licence

Dated at Melbourne 9 October 2003

Registrar of the Magistrates' Court  
GRAEME J. HORSBURGH  
Principal Registrar  
Magistrates' Court of Victoria

**Planning and Environment Act 1987**

DAREBIN PLANNING SCHEME

Notice of Approval of Amendment

Amendment C37

The Minister for Planning has approved Amendment C37 to the Darebin Planning Scheme.

The Amendment comes into operation on the date this notice is published in the Government Gazette.

The Amendment applies the heritage overlay to land known as 66 Spring Street, Preston.

A copy of the Amendment can be inspected, free of charge, during office hours, at the Department of Infrastructure, Planning Information Centre, Upper Plaza, Nauru House, 80 Collins Street, Melbourne and at the offices of the Darebin City Council, 274 Gower Street, Preston.

PAUL JEROME  
General Manager  
Planning, Land Services and  
Environmental Regulation  
Department of Sustainability  
and Environment

**Planning and Environment Act 1987**

## EAST GIPPSLAND PLANNING SCHEME

## Notice of Approval of Amendment

## Amendment C14

The Minister for Planning has approved Amendment C14 to the East Gippsland Planning Scheme.

The Amendment comes into operation on the date this notice is published in the Government Gazette.

The Amendment:

- introduces a new Local Policy — 22.15 — Colquhoun Development Policy applying to the Colquhoun area, north of Lakes Entrance bounded by: the Colquhoun Forest, to the north; Princes Highway to the east; Ostlers Road and Thorpes Lane, to the south, and the North Arm and Harrison Track, to the west;
- rezones various properties located in the Colquhoun area from Rural Zone to Rural Living Zone;
- introduces a new Schedule 4 to the Rural Living Zone.

A copy of the Amendment can be inspected, free of charge, during office hours, at the Department of Sustainability and Environment, Planning Information Centre, Upper Plaza, Nauru House, 80 Collins Street, Melbourne and at the offices of the East Gippsland Shire Council, 273 Main Street, Bairnsdale.

PAUL JEROME  
General Manager  
Planning, Land Services and  
Environmental Regulation  
Department of Sustainability  
and Environment

**Planning and Environment Act 1987**

## MANNINGHAM PLANNING SCHEME

## Notice of Approval of Amendment

## Amendment C15

The Minister for Planning has approved Amendment C15 to the Manningham Planning Scheme.

The Amendment comes into operation on the date this notice is published in the Government Gazette.

The Amendment amends the schedules to the Public Use Zone and Public Park and Recreation Zone enabling a broader range of signage on specific appropriate sites.

A copy of the Amendment can be inspected, free of charge, during office hours, at the Department of Sustainability and Environment, Planning Information Centre, Upper Plaza, Nauru House, 80 Collins Street, Melbourne and at the offices of the Manningham City Council, Civic Centre, 699 Doncaster Road, Doncaster.

PAUL JEROME  
General Manager  
Planning, Land Services and  
Environmental Regulation  
Department of Sustainability  
and Environment

**Planning and Environment Act 1987**

## MORELAND PLANNING SCHEME

## Notice of Approval of Amendment

## Amendment C39

The Minister for Planning has approved Amendment C39 to the Moreland Planning Scheme.

The Amendment comes into operation on the date this notice is published in the Government Gazette.

The Amendment deletes land at 173 properties across the municipality from the Environmental Audit Overlay.

A copy of the Amendment can be inspected, free of charge, during office hours, at the Department of Sustainability and Environment, Planning Information Centre, Upper Plaza, Nauru House, 80 Collins Street, Melbourne and at the offices of the Moreland City Council, 90 Bell Street, Coburg.

PAUL JEROME  
General Manager  
Planning, Land Services and  
Environmental Regulation  
Department of Sustainability  
and Environment

**Planning and Environment Act 1987**  
WELLINGTON PLANNING SCHEME

Notice of Approval of Amendment  
Amendment C19

The Minister for Planning has approved Amendment C19 to the Wellington Planning Scheme.

The Amendment comes into operation on the date this notice is published in the Government Gazette.

The Amendment:

- deletes the Environmental Audit Overlay from Lot 1 Plan of Subdivision 209648, Part Crown Allotment 10, Section B, Parish of Tinamba and Part Crown Allotment 11, Section B, Parish of Tinamba, located Firebrace Road and Heyfield—Jamieson Road, Heyfield; and
- applies the Environmental Audit Overlay to Lot 1 Plan of Subdivision 315813 and Reserve Plan of Subdivision 315813, located Firebrace Road and Heyfield—Jamieson Road, Heyfield.

A copy of the Amendment can be inspected, free of charge, during office hours, at the Department of Sustainability and Environment, Planning Information Centre, Upper Plaza, Nauru House, 80 Collins Street, Melbourne and at the offices of the Wellington Shire Council, 70 Foster Street, Sale.

PAUL JEROME  
General Manager  
Planning, Land Services and  
Environmental Regulation  
Department of Sustainability  
and Environment

**Planning and Environment Act 1987**  
WHITTLESEA PLANNING SCHEME

Notice of Approval of Amendment  
Amendment C48

The Minister for Planning has approved Amendment C48 to the Whittlesea Planning Scheme.

The Amendment comes into operation on the date this notice is published in the Government Gazette.

The Amendment rezones land at 51–57 and 59–61 Duffy Street, Epping from Public Park and Recreation Zone to Industrial 3 Zone.

A copy of the Amendment can be inspected, free of charge, during office hours, at the Department of Sustainability and Environment, Planning Information Centre, Upper Plaza, Nauru House, 80 Collins Street, Melbourne and at the offices of the Whittlesea City Council, Ferres Boulevard, South Morang.

PAUL JEROME  
General Manager  
Planning, Land Services and  
Environmental Regulation  
Department of Sustainability  
and Environment

**Planning and Environment Act 1987**  
YARRA PLANNING SCHEME

Notice of Approval of Amendment  
Amendment C45

The Minister for Planning has approved Amendment C45 to the Yarra Planning Scheme.

The Amendment comes into operation on the date this notice is published in the Government Gazette.

The Amendment removes the Public Acquisition Overlay from 149–153 Barkly Avenue and 451–459 Burnley Street, Burnley; and rezones the following pocket parks to the Public Park and Recreation Zone:—

- (a) Flockhart Reserve — Flockhart Street, Abbotsford;
- (b) Browns Reserve — Nicholson Street, Abbotsford;
- (c) Gary Owens Park — Leicester Street, Fitzroy;
- (d) Studley Street Reserve — Studley Street, Abbotsford;
- (e) King Park — Bell Street, Fitzroy;
- (f) McNamara Reserve — Kelle/Gold Street, Collingwood;
- (g) King William Reserve — King William Street, Fitzroy;
- (h) Clifton Reserve — Clifton Street, Clifton Hill;
- (i) Edwards Place — Falconer/Scotchmer Street, North Fitzroy;

- (j) Liverpool Street Park — Liverpool Street, North Fitzroy;
- (k) Batman Street Reserve — Batman Street, North Fitzroy;
- (l) Dame Nelle Melba — Coppin Street, Richmond;
- (m) Alexandra Reserve — Berry and Hodgen Terrace, Richmond;
- (n) Athol J. Brown — Burnley/Madden Grove; and
- (o) Shakespeare Street Reserve — Shakespeare Street, North Carlton.

A copy of the Amendment can be inspected, free of charge, during office hours, at the Department of Sustainability and Environment, Planning Information Centre, Upper Plaza, Nauru House, 80 Collins Street, Melbourne and at the offices of the Yarra City Council, Richmond Town Hall, 333 Bridge Road, Richmond.

PAUL JEROME  
General Manager  
Planning, Land Services and  
Environmental Regulation  
Department of Sustainability  
and Environment

---

**Planning and Environment Act 1987**

**GREATER GEELONG PLANNING SCHEME**

Notice of Lapsing of Amendment  
Amendment C41

The Greater Geelong City Council has resolved to abandon Amendment C41 to the Greater Geelong Planning Scheme.

The Amendment proposed to apply a Neighbourhood Character Overlay over the foreshore areas of Ocean Grove affecting approximately 1070 properties.

The Amendment lapsed on 9 October 2003.

PAUL JEROME  
General Manager  
Planning, Land Services and  
Environmental Regulation  
Department of Sustainability  
and Environment

---

**Planning and Environment Act 1987**

**KNOX PLANNING SCHEME**

Notice of Lapsing of Amendment  
Amendment C17

The Knox City Council has resolved to abandon Amendment C17 to the Knox Planning Scheme.

The Amendment proposed to:

- rezone the northern (front) section of the car dealership at 700 Burwood Highway, Ferntree Gully from the Business 2 Zone (B2Z) to the Business 4 Zone (B4Z);
- rezone the southern (rear) section of the car dealership at 700 Burwood Highway from the Residential 1 Zone (R1Z) to the Business 4 Zone (B4Z);
- rezone 694 and 696 Burwood Highway from the Residential 1 Zone (R1Z) to the Business 4 Zone (B4Z);
- rezone the petrol station site at 704 Burwood Highway from the Business 2 Zone (B2Z) to the Business 4 Zone (B4Z);
- remove Vegetation Protection Overlay Schedule 1 from the land at 700 Burwood Highway;
- apply Development Plan Overlay Schedule 9 (DPO9) to the three parcels of land known as 694, 696 and 700 Burwood Highway to require approval of an overall development plan for the site prior to any planning approval for use and development of the land.

The Amendment lapsed on 1 October 2003.

PAUL JEROME  
General Manager  
Planning, Land Services and  
Environmental Regulation  
Department of Sustainability  
and Environment

---

**ORDERS IN COUNCIL**

**Crown Land (Reserves) Act 1978**  
**TEMPORARY RESERVATION OF**  
**CROWN LAND**

The Lieutenant-Governor as the Governor's Deputy, with the advice of the Executive Council under section 4(1) of the **Crown Land (Reserves) Act 1978** temporarily reserves the following Crown land which in his opinion is required for the purpose mentioned—

**MUNICIPAL DISTRICT OF THE**  
**BENALLA RURAL CITY COUNCIL**

**BADDAGINNIE**—Conservation of an area of natural interest, total area 4.3551 hectares, being Crown Allotments 41A, 43A & 35D, Township of Baddaginnie, Parish of Warrenbayne as indicated on Original Plan No.122012 lodged in the Central Plan Office.—(09L7/5693).

**MUNICIPAL DISTRICT OF THE**  
**MOIRA SHIRE COUNCIL**

**BARWO**—Conservation of an area of natural interest, total area 9.950 hectares, being Crown Allotment 20A, Section F, Parish of Barwo as indicated by hatching on plan hereunder. (GP1265)—(09L7/5707).

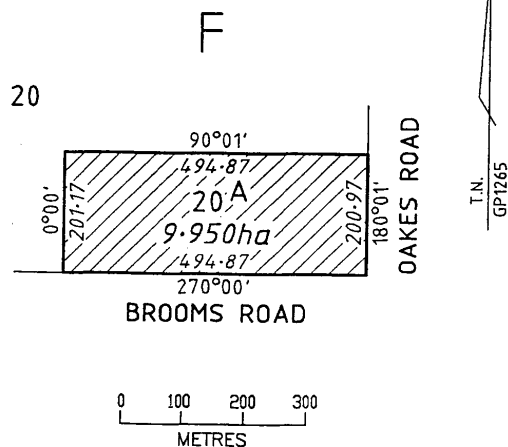

**MUNICIPAL DISTRICT OF THE**  
**BENALLA RURAL CITY COUNCIL**

**BOWEYA**—Conservation of an area of natural interest, total area 3.596 hectares, being Crown Allotment 22F, Parish of Boweya as indicated by hatching on plan hereunder. (GP1270)—(09L7/5694).

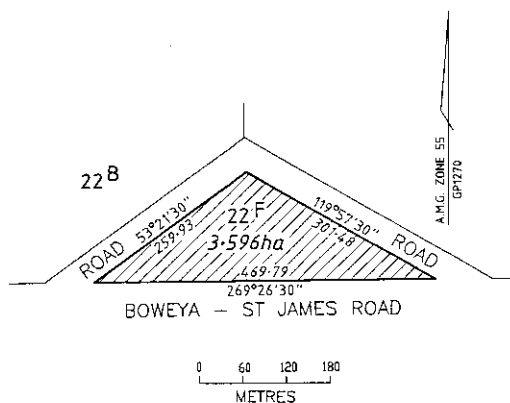

**MUNICIPAL DISTRICT OF THE**  
**BENALLA RURAL CITY COUNCIL**

**BOWEYA**—Conservation of an area of natural interest, total area 8472 square metres, being Crown Allotment 1A, Parish of Boweya as indicated by hatching on plan hereunder. (GP1269)—(09L7/5687).

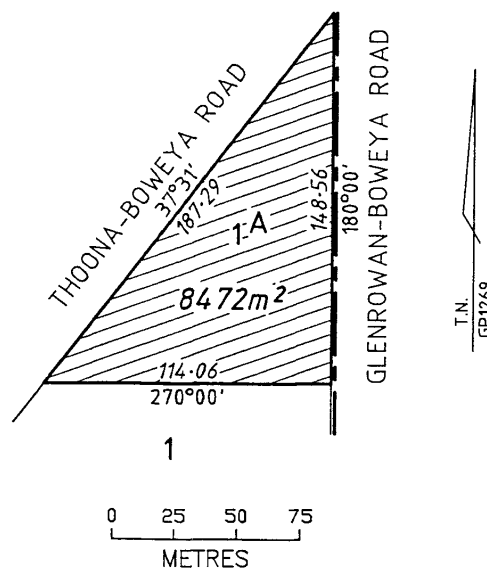

**MUNICIPAL DISTRICT OF THE**  
**BENALLA RURAL CITY COUNCIL**

**GOOMALIBEE**—Conservation of an area of natural interest, total area 1.871 hectares, being Crown Allotment 39C, Parish of Goomalibee as indicated by hatching on plan hereunder. (GP1266)—(09L7/5684).



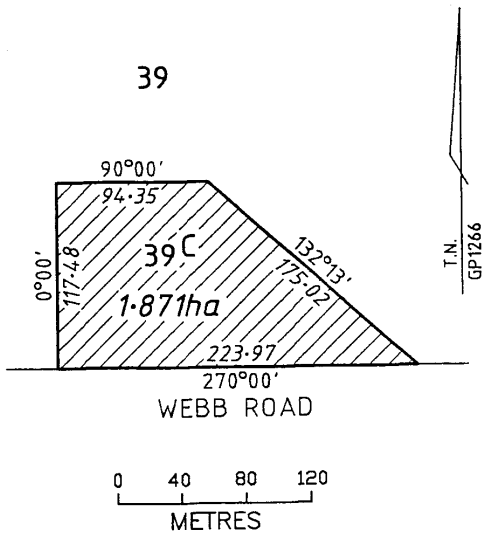

MUNICIPAL DISTRICT OF THE  
BENALLA RURAL CITY COUNCIL

GOOMALIBEE—Conservation of an area of natural interest, total area 3.548 hectares, being Crown Allotment 41D, Parish of Goomalibee as indicated by hatching on plan hereunder. (GP1268)—(09L7/5683).

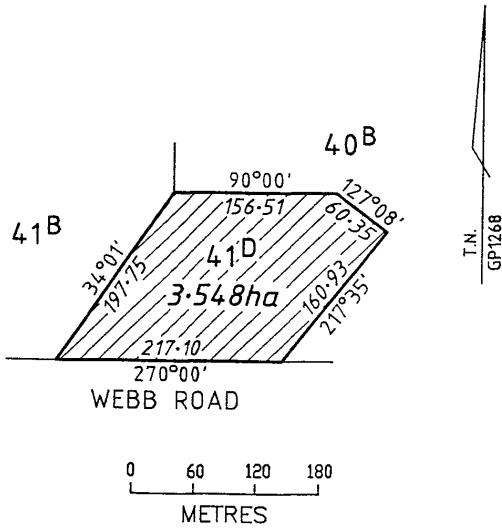

MUNICIPAL DISTRICT OF THE  
MOIRA SHIRE COUNCIL

KAARIMBA—Conservation of an area of natural interest, total area 15.13 hectares, being Crown Allotment 28B, Section B, Parish of Kaarimba as indicated by hatching on plan hereunder. (GP1292)—(2012551).

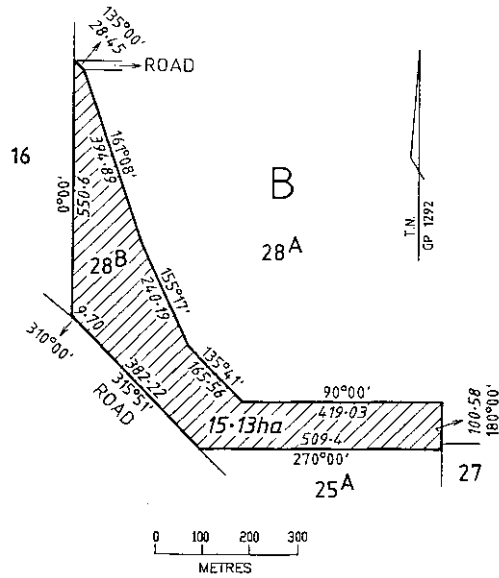

MUNICIPAL DISTRICT OF THE  
MOIRA SHIRE COUNCIL

KAARIMBA—Conservation of an area of natural interest, total area 32.24 hectares, being Crown Allotment 14B, Section D, Parish of Kaarimba as indicated by hatching on plan hereunder. (GP1200)—(09L7/5705).

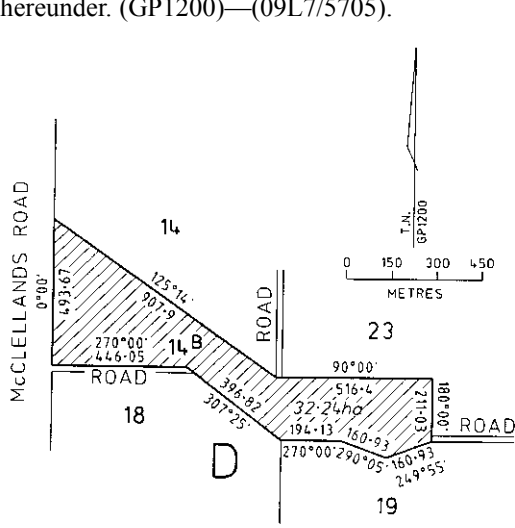

MUNICIPAL DISTRICT OF THE  
MOIRA SHIRE COUNCIL

KOTUPNA—Conservation of an area of natural interest, total area 3.571 hectares, being Crown Allotment 50C, Parish of Kotupna as indicated by hatching on plan hereunder. (GP1199)—(09L7/5702).

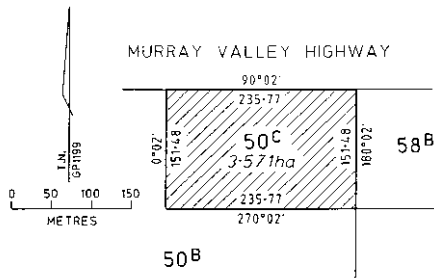

MUNICIPAL DISTRICT OF THE MOIRA SHIRE COUNCIL

KOTUPNA—Conservation of an area of natural interest, total area 5.252 hectares, being Crown Allotment 61D, Parish of Kotupna as indicated by hatching on plan hereunder. (GP1187)—(09L7/5703).

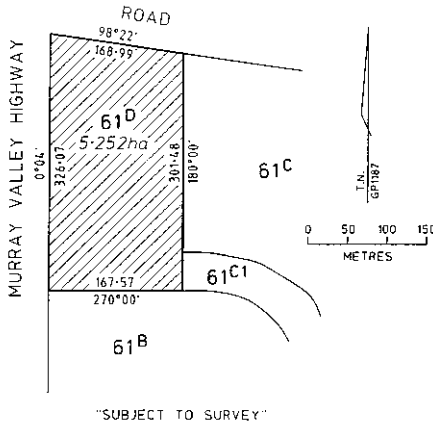

MUNICIPAL DISTRICT OF THE MOIRA SHIRE COUNCIL

MOIRA—Conservation of an area of natural interest, total area 8 hectares, being Crown Allotment 14A, Section A, Parish of Moira as indicated by hatching on plan hereunder. (GP1282)—(2012547).

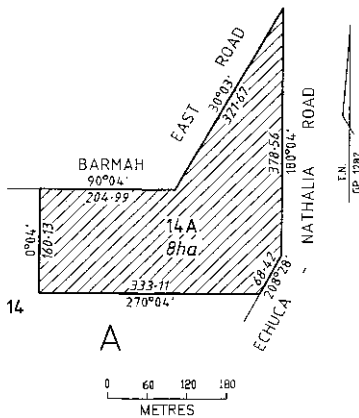

MUNICIPAL DISTRICT OF THE MOIRA SHIRE COUNCIL

MOIRA—Conservation of an area of natural interest, total area 2.428 hectares, being Crown Allotment 1B, Section B, Parish of Moira as indicated by hatching on plan hereunder. (GP1264)—(09L7/5704).

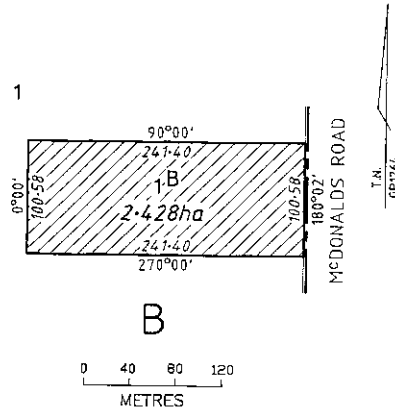

MUNICIPAL DISTRICT OF THE MOIRA SHIRE COUNCIL

NARINGANINGALOOK—Conservation of an area of natural interest, total area 8094 square metres, being Crown Allotment 20A, Section F, Parish of Naringalingalook as indicated by hatching on plan hereunder. (GP1291)—(2012562).

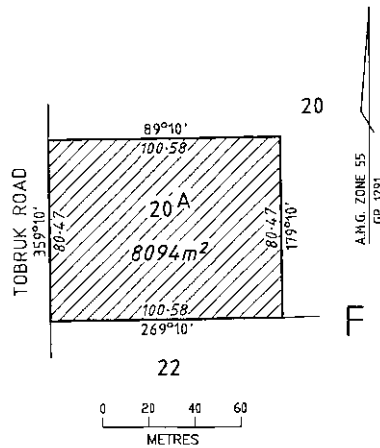

MUNICIPAL DISTRICT OF THE MOIRA SHIRE COUNCIL

NARIOKA—Conservation of an area of natural interest, total area 2.177 hectares, being Crown Allotment 15A, Section 4, Parish of Narioka as indicated by hatching on plan hereunder. (GP1256)—(09L7/5706).

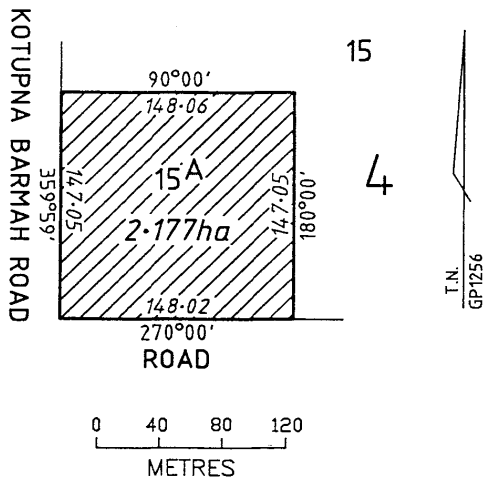

MUNICIPAL DISTRICT OF THE  
BENALLA RURAL CITY COUNCIL

THOONA—Conservation of an area of natural interest, total area 10.43 hectares, being Crown Allotment 3C, Section 14, Township of Thoona, Parish of Mokoan as indicated by hatching on plan hereunder. (GP1280)—(09L7/5691).

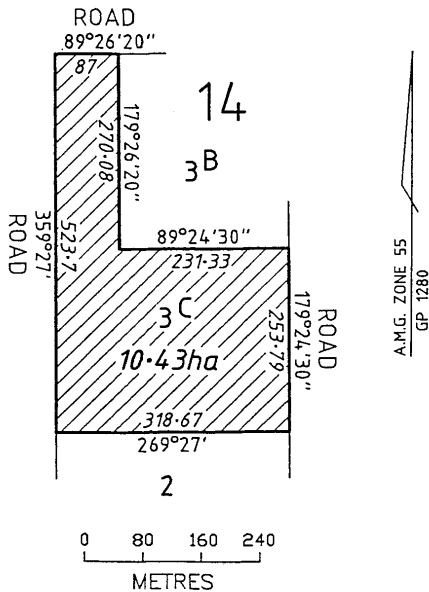

MUNICIPAL DISTRICT OF THE  
MOIRA SHIRE COUNCIL

TUNGAMAH—Conservation of an area of natural interest, total area 4.050 hectares, being Crown Allotment 5A, Section 28, Township of Tungamah, Parish of Tharanbegga as indicated on Certified Plan No.110401 lodged in the Central Plan Office.—(2012597).

This Order is effective from the date on which it is published in the Government Gazette.

Dated 14 October 2003

Responsible Minister  
MARY DELAHUNTY  
Minister for Planning

SUDHA KASYNATHAN  
Acting Clerk of the Executive Council

**Crown Land (Reserves) Act 1978**  
**Interpretation of Legislation Act 1984**  
AMENDMENT OF TEMPORARY  
RESERVATIONS

The Lieutenant-Governor as the Governor's Deputy, with the advice of the Executive Council, under Section 4(1) of the **Crown Land (Reserves) Act 1978** and Section 27 of the **Interpretation of Legislation Act 1984** amends—

BARWO—the Order in Council made on 19 March, 1884 and published in the Government Gazette on 28 March 1884—page 831 of the temporary reservation of an area of 6.392 hectares, in the Parish of Barwo, County of Moira as a Site for affording Access to Water, by the deletion of the words "Site for affording Access to Water" and the substitution therefor of the words "Conservation of an area of natural interest";—(Rs 867) (GP1260).

KOTUPNA—the Order in Council made on 8 April 1879 and published in the Government Gazette on 10 April 1884—page 833 of the temporary reservation of an area of 3.369 hectares, in the Parish of Kotupna, County of Moira as a site for Watering purposes by the deletion of the words "Site for Watering purposes" and the substitution therefor of the words "Conservation of an area of natural interest";—(Rs 7113) (GP1261)

This Order is effective from the date on which it is published in the Government Gazette.

Dated 14 October 2003

Responsible Minister  
MARY DELAHUNTY  
Minister for Planning

SUDHA KASYNATHAN  
Acting Clerk of the Executive Council

**Crown Land (Reserves) Act 1978**  
 INCORPORATION OF COMMITTEES OF MANAGEMENT AND  
 APPOINTMENT OF CHAIRMEN

The Lieutenant-Governor as the Governor's deputy, with the advice of the Executive Council, under section 14A(1) of the **Crown Land (Reserves) Act 1978**, being satisfied that it is in the public interest to declare to be corporations the Committees of Management appointed under section 14(2) of the Act of the lands described in Column 1 of the schedule hereunder—

(a) declares that the Committees of Management shall be corporations;

(b) assigns the names shown in Column 2 to the corporations; and

under section 14B(3) of the Act, appoints the persons listed in Column 3 to be Chairmen of the corporations.

**SCHEDULE**

Column 1 Reserve details	Column 2 Corporate name	Column 3 Chairman
<b>Napoleons Public Hall Reserve</b> — The land in the Township of Napoleons temporarily reserved for a Public Hall by Order in Council of 26 February, 1957 (vide Government Gazette of 6 March, 1957—page 863) [Rs 7541].	Napoleons Memorial Hall Committee Incorporated	Kevin William McMANUS
<b>Red Hill Public Recreation and Public Hall Reserve</b> —The land in the Parish of Jancourt temporarily reserved for Public Recreation and Public Hall by Order in Council of 10 October, 1978 (vide Government Gazette of 18 October, 1978—page 3287) [Rs 10633].	Red Hill Public Hall Incorporated	Erich WAGNER
<b>Skipton Mechanics' Institute and Public Purposes Reserves</b> — The lands in the Township of Skipton temporarily reserved for Mechanics' Institute by Order in Council of 13 September, 1880; for Public purposes by Order in Council of 22 February, 2000 together with the adjoining permanent frontage to Mount Emu Creek as coloured green on plan "S/15.9.1999" attached to Department of Natural Resources and Environment file Rs 2655 [Rs 2655].	Skipton Mechanics' Hall Committee Incorporated	Ruby Francis HALEY
<b>Benambra Public Recreation Reserves</b> —The lands in the Township of Benambra temporarily reserved for public recreation by Orders in Council of 10 October, 1893 and 5 May, 1964 (vide Government Gazette of 13 October, 1893—page 4121 and 3 May, 1964—1448) [Rs 7061].	Benambra Recreation Reserve Incorporated	Andrew Ian NICHOLAS

<b>Column 1 Reserve details</b>	<b>Column 2 Corporate name</b>	<b>Column 3 Chairman</b>
<b>Cassilis Public Recreation Reserve</b> —The land in the Parish of Jirnkee temporarily reserved for Public Recreation by Order in Council of 5 October, 1896 (vide Government Gazette of 9 October, 1896—page 4156) [Rs 1250].	Cassilis Recreation Reserve Incorporated	David HARVEY
<b>Club Terrace Public Hall Reserve</b> —The land in the Township of Club Terrace temporarily reserved for Public Recreation by Order in Council of 30 April, 1957 (vide Government Gazette of 8 May, 1957—page 1497) [Rs 7563].	Club Terrace Hall Committee Incorporated	Peter DESPOT
<b>Forrest Public Hall and Water Reserve</b> —The land in the Parish of Yauger temporarily reserved for Public Purposes (Public Hall) by Order in Council of 13 April, 1965 (vide Government Gazette of 23 April, 1965—page 1399) and for the additional purpose of Water Supply by Order in Council of 30 October, 1968 (vide Government Gazette of 6 November, 1968—page 3675) [Rs 8431].	Forrest Public Hall Committee Incorporated	Adrian John BROWN

This Order is effective from the date on which it is published in the Government Gazette.

Dated 14 October 2003

Responsible Minister  
 MARY DELAHUNTY  
 Minister for Planning

SUDHA KASYNATHAN  
 Acting Clerk of the Executive Council

**SUBORDINATE LEGISLATION ACT 1994  
NOTICE OF MAKING OF STATUTORY  
RULES**

Notice is hereby given under Section 17 (2) of the **Subordinate Legislation Act 1994** of the making of the following Statutory Rules:

120. *Statutory Rule:* Pharmacists (Interim) (Fees) Regulations 2003  
*Authorising Act:* Pharmacists Act 1974  
*Date of making:* 14 October 2003
121. *Statutory Rule:* Occupational Health and Safety (Prevention of Falls) Regulations 2003  
*Authorising Act:* Occupational Health and Safety Act 1985  
*Date of making:* 14 October 2003

**SUBORDINATE LEGISLATION ACT 1994  
NOTICE THAT STATUTORY RULES ARE  
OBTAINABLE**

Notice is hereby given under Section 17 (3) of the **Subordinate Legislation Act 1994** that the following Statutory Rules were first obtainable from Information Victoria, 356 Collins Street, Melbourne on the date specified:

119. *Statutory Rule:* Fair Trading (Amendment) Regulations 2003  
*Authorising Act:* Fair Trading Act 1999  
*Date first obtainable:* 14 October 2003  
*Code A*

**PRICING FOR SPECIAL GAZETTE,  
PERIODICAL GAZETTE AND  
VICTORIAN LEGISLATION**

Retail price varies according to the number of pages in each Victoria Government Special Gazette, Victoria Government Periodical Gazette and Victorian legislation. The table below sets out the prices that apply.

<i>Price Code</i>	<i>No. of Pages (Including cover and blank pages)</i>	<i>Price*</i>
A	1–16	\$3.65
B	17–32	\$5.40
C	33–48	\$7.40
D	49–96	\$11.50
E	97–144	\$14.85
F	145–192	\$17.55
G	193–240	\$20.25
H	241–288	\$21.55
I	289–352	\$24.25
J	353–416	\$28.35
K	417–480	\$32.35
L	481–544	\$37.75
M	545–608	\$43.15
N	609–672	\$48.55
O	673–736	\$53.90
P	737–800	\$59.30

*\*All Prices Include GST*

**craftsmanpress**

The *Victoria Government Gazette* is published by The Craftsman Press Pty Ltd with the authority of the Government Printer for the State of Victoria

© State of Victoria 2003

This publication is copyright. No part may be reproduced by any process except in accordance with the provisions of the Copyright Act.

Address all enquiries to the Government Printer for the State of Victoria  
Level 2 1 Macarthur Street  
Melbourne 3002  
Victoria Australia

**How To Order**

**Mail Order**      **Craftsman Press Pty Ltd**  
125 Highbury Road  
Burwood 3125  
DX – 32510 Burwood



**Telephone**      (03) 9926 1233



**Fax**      (03) 9926 1292

**email**      [gazette@craftpress.com.au](mailto:gazette@craftpress.com.au)



**Retail & Mail Sales**      **Information Victoria**  
356 Collins Street  
Melbourne 3000



**Telephone**      1300 366 356



**Fax**      (03) 9603 9920



**Retail Sales**      **City Graphics**  
Level 1 520 Bourke Street  
Melbourne 3000



**Telephone**      (03) 9600 0977



**Fax**      (03) 9600 0989

**Recommended Retail Price \$1.95 (includes GST)**

ISSN 0819-5471



9 770819 549977