



Victoria Government Gazette

No. G 21 Thursday 22 May 2003

GENERAL

GENERAL AND PERIODICAL GAZETTE

Copy to: Gazette Officer
The Craftsman Press Pty. Ltd.
125 Highbury Road,
Burwood Vic 3125
Telephone: (03) 9926 1233
Facsimile: (03) 9926 1292
DX: 32510 Burwood
Email: gazette@craftpress.com.au

Advertising Rates and Payment

All prices include GST

Private Notices

Payment must be received in advance with advertisement details.

33 cents per word – Full page \$198.00.

Additional costs must be included in prepayment if a copy of the gazette is required. Copy Prices – Page

\$1.65 – Gazette \$3.52 – Certified copy of Gazette \$3.85

(all prices include postage). **Cheques should be made payable to The Craftsman Press Pty. Ltd.**

Government and Outer Budget Sector Agencies Notices

Not required to prepay.

Advertisements may be faxed or sent via email with a

cover sheet, marked to the attention of the Gazette Officer.

Floppy Disks (Mac & PC) can also be accepted.

Costs can be calculated on the following basis:

Per Line	Typeset
Single column	\$1.71
Double column	\$3.41
Full Page	\$71.28

The Craftsman Press is pleased to offer a series of discounts from the typesetting costs.

1. Copy supplied on disk.
2. Copy supplied via email.
3. Artwork for forms and other material which require exact reproduction.

1. Copy supplied on disk.

Where a disk is supplied and there is minimum alteration required, **30% off.**

Where a disk is supplied requiring extraneous matter stripped out and styles applied, **20% off.**

2. Copy supplied via email.

Where a notice is sent via email and there is minimum alteration required, **25% off.**

Where email is supplied requiring extraneous matter stripped out and styles applied, **15% off.**

3. Artwork for forms and other material which requires exact reproduction.

Scanning and sizing of artwork for forms, to be reproduced in page format, **35% off.**

Copy Deadline for General Gazette

9.30 a.m. Monday – (Private Notices)

9.30 a.m. Tuesday – (Government and Outer Budget Sector Agencies Notices)

Advertisers should note:

- Late copy received at The Craftsman Press Pty. Ltd. after deadlines will be placed in the following issue of VGG, irrespective of any date/s mentioned in the copy (unless otherwise advised).
- Late withdrawal of advertisements (after client approval, before printing) will incur 50 per cent of the full advertising rate to cover typesetting, layout and proofreading costs.
- Proofs will be supplied only when requested or at the direction of the Gazette Officer.
- No additions or amendments to material for publications will be accepted by telephone.
- Orders in Council may be lodged prior to receiving assent with the Governor's or Clerk's signature. They will only be published once approved and signed.
- Accounts over 90 days will be issued with a letter of demand.
- Government and Outer Budget Sector Agencies please note: *See style requirements on back page.*

SPECIAL GAZETTES

Copy to: Gazette Officer
The Craftsman Press Pty. Ltd.
125 Highbury Road
Burwood Vic 3125
Telephone: (03) 9926 1233
Facsimile: (03) 9926 1292
Email: gazette@craftpress.com.au

Advertising Rates and Payment

Private Notices

Full Page \$396.00

Payment must be received in advance with notice details.

Government and Outer Budget Sector Agencies Notices

Full Page
Typeset
\$106.92

Note:

The after hours numbers for Special Gazettes are:

Telephone: **0419 327 321**
0419 325 882
0417 391 171

SUBSCRIPTIONS AND RETAIL SALES

Copies of the *Victoria Government Gazette* can be purchased from The Craftsman Press Pty. Ltd. by subscription.

The *Victoria Government Gazette*

General and Special – \$198.00 each year

General, Special and Periodical – \$264.00 each year

Periodical – \$132.00 each year

Subscriptions are payable in advance and accepted for a period of one year. All subscriptions are on a firm basis and refunds will not be given.

All payments should be made payable to The Craftsman Press Pty. Ltd.

Subscription enquiries:

The Craftsman Press Pty. Ltd.
125 Highbury Road, Burwood Vic 3125

INDEX TO PRIVATE ADVERTISERS

A	K
A.B. Natoli Pty.1157	K. P. Abbott & Co.1160
Andrew P. Melville1157	Kelly & Chapman1161
Armstrong Ross1157	
Ashfords1157	L
	Lucas Lawyers1161
B	Lynch & MacDonald1161
Borchard & Moore1158	
	M
C	Mason Sier Turnbull1161
Chessell Williams1158	Mills Oakley1161
	Mosley & Palmer1161
D	
David Stagg Tonkin & Company1158	N
Davis & Marks1158	Nicholas O'Donohue & Co.1161
Deanna Smyth1158	
	O
E	O'Farrell Robertson McMahon1162
E. P. Johnson & Davies1158	
	P
F	Pearce Webster Dugdales1162
Fraser, Nevett & Frawley1159	Perpetual Trustees Victoria Limited1162
	Pietrzak Solicitors1162
G	
G. W. H. Chambers1159	R
Garden & Green1159	Rennick & Gaynor1163
Geoff Dillon & Co.1159	Rigby Cooke1163
Gray Friend & Long1159	Russo Pellicano Carlei1163
Gullaci & Gullaci1160	
	T
H	T.J. Mulvany & Co.1163
Hassall & Byrne1160	
	W
I	Wills & Probate Victoria1163
Ian F. Apted1160	

Advertisers Please Note

All advertisers please note that from Thursday, 1 May 2003 the following rates apply:

SERVICE FEES

Private Notices (Pre-paid)	Rate	Rate incl. GST
Cost per word	\$0.30	\$0.33
Cost per faxed copy of page containing client's notice	\$1.50	\$1.65
Cost per copy of Gazette containing client's notice plus postage	\$3.20	\$3.52

Unclaimed Moneys (Pre-paid)	Rate	Rate incl. GST
Cost per column centimetre	\$9.30	\$10.32
Cost per full page	\$171.50	\$188.65

Government and Outer Budget Sector Agencies Notices	Rate	Rate incl. GST
Note: 15% discount for emailed copy		
Cost per column centimetre	\$4.65	\$5.12
Cost per half page	\$33.95	\$37.35
Cost per full page	\$64.80	\$71.28

Special Gazettes

Special Gazettes attract a 50% surcharge on the above rates.

Subscription, Fees and Discounts (incl. GST)

General, Special and Periodical	\$264.00 per annum
General and Special	\$198.00 " "
Periodical	\$132.00 " "

General Gazettes per copy	\$1.95 (incl. GST)
---------------------------	--------------------

All other charges remain unchanged until further notice.

**PUBLICATION OF THE VICTORIA GOVERNMENT GAZETTE (GENERAL)
QUEEN'S BIRTHDAY**

Please Note:

The Victoria Government Gazette for Queen's Birthday week will be published on **Thursday 12 June 2003**.

Copy deadlines:

Private Advertisements **9.30am on Friday 6 June 2003.**

Government and Outer

Budget Sector Agencies Notices **9.30am on Tuesday 10 June 2003.**

Where urgent gazettal is required after hours, arrangements should be made with the Government Gazette Officer on 0419 327 321.

JENNY NOAKES
Government Gazette Office

PRIVATE ADVERTISEMENTS

HOMICIDE

Reward \$100,000.00

The co-operation of the public is sought to establish the identity of the person or persons responsible for the death of Hashim HAMID, who died as a result of injuries he received on 24 May 2002 in Reynolds Street, North Melbourne.

A reward of up to one hundred thousand dollars (\$100,000.00) will be paid at the discretion of the Chief Commissioner of Police, for information leading to the apprehension and subsequent conviction of any person responsible for the death of Hashim HAMID.

Any information, which will be treated as confidential, may be given at any time to Crime Stoppers via Telephone number, Toll Free – 1800 333 000, or the Homicide Squad, 412 St Kilda Road, Melbourne on telephone number (03) 9865 2770 during normal business hours.

CHRISTINE NIXON
Chief Commissioner of Police

BETTY LOVELL CUMMING, late of 1 Birdwood Avenue, Kew East, retired mathematician, deceased. Creditors, next-of-kin and others having claims in respect of the estate of the abovenamed deceased, who died on 16 February 2003, are required by Janet Lovell Downing, the executor of the deceased's Will, to send particulars of their claim to the said executor care of the undermentioned solicitors by a date not later than two months from the date of publication hereof, after which date she will convey or distribute the assets having regard only to the claims of which she then has notice.

A. B. NATOLI PTY., solicitors,
24 Cotham Road, Kew 3101.

EUGENIUSZ HALASA, (in the Will called Eugene Halassa), late of 39 Miller Road, Bayswater, Victoria, retired gentleman, deceased. Creditors, next-of-kin and others having claims in respect of the estate of the abovenamed deceased, who died on 29 January 2003, are required by Richard Halasa, the

executor of the deceased's Will, to send particulars of their claim to the said executor care of the undermentioned solicitors by a date not later than two months from the date of publication hereof, after which date he will convey or distribute the assets having regard only to the claims of which he then has notice.

A. B. NATOLI PTY., solicitors,
24 Cotham Road, Kew 3101.

Re: DARCY WILLIAM FUGE, deceased

Creditors, next-of-kin and others having claims against the estate of DARCY WILLIAM FUGE, late of 23 Campbell Street, Rutherglen, Victoria, retired, who died on 5 March 2003, are required to send particulars of their claims to Daryl William Fuge and Maree Patricia Sparks care of Andrew P. Melville of 110 Main Street, Rutherglen 3685, the personal representatives on or before 20 July 2003 after which date they may convey or distribute the assets having regard only to the claims of which they then have notice.

ANDREW P. MELVILLE,
barristers & solicitors,
110 Main Street, Rutherglen 3685.

Re: Estate of ELVA MAY EBBOTT, deceased.

Creditors, next-of-kin or others having claims in respect of the estate of ELVA MAY EBBOTT, late of Unit 3, 12 Bayview Avenue, Upwey, Victoria, home duties, deceased, who died on 8 February 2003, are to send particulars of their claim to the executors care of the undermentioned solicitors by 31 July 2003 after which date the executors will distribute the assets having regard only to the claims of which they then have notice.

ARMSTRONG ROSS, barristers & solicitors,
Suite 1, 1693A Burwood Highway, Belgrave.

PERCY HENRY EMMETT, late of 811 Burwood Highway, Ferntree Gully, retired, deceased, who died on 23 December 2002. Creditors, next-of-kin and all others having claims in respect of the estate of the deceased,

are required by the executor, Roy Henry John Emmett of 33 Drysdale Street, Macleod, to send particulars of their claims to him in the care of the undermentioned solicitors prior to 22 July 2003 after which date he will distribute the assets of the estate having regard only to the claims of which he then has notice.

ASHFORDS, solicitors,
Level 50, 101 Collins Street, Melbourne 3000.

Re: SUSAN ELIZABETH SHOLSON, late of 73 Temple Road, Selby, Victoria, national product manager, deceased. Creditors, next-of-kin and others having claims in respect of the estate of the deceased, who died on 11 January 2003, are required by the trustee, Cheryl Ann Willem of 3900 Maryborough–Talbot Road, Clunes, Victoria, nurse, the sister, to send particulars to the trustee by 1 August 2003 after which date the trustee may convey or distribute the assets, having regard only to the claims of which the trustee has notice.

BORCHARD & MOORE, solicitors,
44 Douglas Street, Noble Park 3174.

Re: ASTLEY ARTHUR COOPER.

Creditors, next-of-kin and others having claims against the estate of ASTLEY ARTHUR COOPER, late of Cabrini Palliative Care Hospital of 646 High Street, Prahran, Victoria, retail liquor merchant, deceased, who died on 18 February 2003, are requested to send particulars of their claims to the executors care of the undermentioned solicitors by 28 July 2003 after which date they will distribute the assets having regard only to the claims on which date they then have notice.

CHESSELL WILLIAMS, solicitors,
379 Collins Street, Melbourne 3000.

MARTA TERESA HAMILTON, late of 55 Silver Street, Eltham, home duties, deceased. Creditors, next-of-kin and others having claims in respect of the estate of the abovenamed deceased, who died on 14 December 2002, are required by Equity Trustees Limited of Level 5, 575 Bourke Street, Melbourne 3000, the legal representative of the deceased, to send particulars of their claims to the said company at GPO Box 2307, Melbourne 3001, no later than 20 July

2003 after which date they will convey or distribute the assets having regard only to the claims of which they then have notice.

DAVID STAGG TONKIN & COMPANY,
legal practitioners,
8–10 Flintoff Street, Greensborough 3088.

Re: STUART FORBES MACLAREN (deceased).

Creditors, next-of-kin or others having claims in respect of the estate of STUART FORBES MACLAREN, late of 2751 Calder Highway, Faraday, in Victoria, deceased, who died on 4 August 2002, are to send particulars of their claims to the executrix, Eleanor Ruth Maclaren, care of the undermentioned solicitors by 22 July 2003 after which date the executrix will distribute the assets having regard only to the claims of which she then has notice.

DAVIS & MARKS, solicitors,
Level 1, 28 Carpenter Street, Brighton 3186.

STUART JOHN SMYTH late of 95 Panorama Drive, Gisborne, in the state of Victoria. Creditors, next of kin and others having claims in respect of the estate of the deceased, who died on 9 June, 2002, are required by the trustees, Deanna Marie Smyth of Lot 18, Collingridge Point, Berowra Waters in the State of New South Wales, and Tanya Christine Smyth of Gruetstrasse 27, Herrliberg, Switzerland, to send particulars to them in the care of Deanna Smyth, PO Box 33, Berowra Heights 2082, by 21 July 2003 after which date the trustees may convey or distribute the assets, having regard only to the claims of which they then have notice.

Ms DEANNA SMYTH,
Lot 18, Collingridge Point,
Berowra Waters 2082

Re: JOHN WILLOUGHBY NEPEAN KENNY (in the Will called John Willoughby Kenny), deceased.

Creditors, next-of-kin and others having claims in respect of the estate of JOHN WILLOUGHBY NEPEAN KENNY (in the Will called John Willoughby Kenny), late of 49 Arnold Street, South Yarra, Victoria, retired

chartered accountant, deceased, who died on 2 June 2002, are to send particulars of their claims to the executors care of the undermentioned solicitors by 31 July 2003 after which date the executors will distribute the assets having regard only to the claims of which the executors then have notice.

E. P. JOHNSON & DAVIES, lawyers,
52 Collins Street, Melbourne,
Solicitors for the applicant.

Re: LEONARD ALBERT WEBB, late of 9 Smith Street, Ballarat, Victoria, company director, deceased. Creditors, next-of-kin and others having claims in respect of the estate of the deceased, who died on 22 June 2002, are required by the trustees, Jeanne Susan Wilkie of 9 Smith Street, Ballarat, Victoria, student, the partner, Daryl James Gardner of 18 Beringa Avenue, Grovedale, Victoria, electrical engineer, no relation and Darrell John Fraser of 41 Lydiard Street South, Ballarat, Victoria, solicitor, no relation, to send particulars to the trustees by 21 July 2003 after which date the trustees may convey or distribute the assets, having regard only to the claims of which the trustees have notice.

FRASER, NEVETT & FRAWLEY, solicitors,
41 Lydiard Street South, Ballarat 3350.

ERIC STUART PARKER, late of 15 Cherbourg Avenue, Beaumaris, plasterer. Creditors, next-of-kin and others having claims in respect of the estate of the deceased, who died on 10 April 2003, are required by the trustees, care of G.W.H. Chambers, solicitor of 338 Charman Road, Cheltenham, to send particulars to them by 23 July 2003 after which date the trustees may convey or distribute the assets, having regard only to the claims of which they then have notice.

G.W.H. CHAMBERS, solicitor,
338 Charman Road, Cheltenham 3192.

Re: FREDERICK LAWRENCE BOULTON, deceased. Creditors, next-of-kin and others having claims in respect of the estate of the deceased, who died on 23 February 2003, are required by the trustees, Dennis Lindsay Boulton and Geoffrey George Boulton to send

particulars to them by 21 July 2003 after which date the trustees may convey or distribute the assets having regard only to the claims of which the trustees have notice.

GARDEN & GREEN, solicitors,
4 McCallum Street, Swan Hill 3585.

JEAN PRIMROSE WHYTE, late of 2A Warburton Street, Camberwell East, in the said State, emeritus professor, deceased. Creditors, next-of-kin and others having claims in respect of the estate of the deceased, who died on 18 March 2003, are required by the executors and trustees, Brian John McMullin of 23 Dean Avenue, Mount Waverley, Victoria 3149 and Geoffrey John Dillon, Level 9, 167 Queen Street, Melbourne, Victoria 3000 (GPO Box 4097, Melbourne, Victoria 3001) to send particulars to them, care of their solicitors, Geoff Dillon & Co., at the undermentioned address by 31 July 2003 after which date the executors and trustees may convey or distribute the assets, having regard only to the claims of which they then have notice.

GEOFF DILLON & CO., commercial lawyers,
Level 9,
167 Queen Street, Melbourne, Victoria 3000
(GPO Box 4097, Melbourne 3001).

ANDREW GORDON VOLUM, late of 332 Normanby Street, Warragul, retired public servant, deceased. Creditors, next-of-kin and others having claims in respect of the estate of the deceased, who died on 3 April 2003, are required by the trustees, Lynette Grace Volum, Robert Forrester Volum and Jane Elizabeth Volum, to send particulars of their claims to them care of the undersigned solicitors by 22 July 2003 after which date the trustees may convey or distribute the assets having regard only to the claims of which they then have notice.

GRAY FRIEND & LONG, solicitors,
70 Queen Street, Warragul 3820.

JEAN CHRISTIAN-JONES, late of Hamiltons Road, Warragul South, married woman, deceased. Creditors, next-of-kin and others having claims in respect of the estate of the deceased, who died on 23 March 2003, are

required by the trustees, Alan Rule Jones and Maren Trenia Stafford, to send particulars of their claims to them care of the undersigned solicitors by 22 July 2003 after which date the trustees may convey or distribute the assets having regard only to the claims of which they then have notice.

GRAY FRIEND & LONG, solicitors,
70 Queen Street, Warragule 3820.

JESSIE ROWENA CHRISTENSEN, late of 13 Clifford Street, Warragule, widow, deceased. Creditors, next-of-kin and others having claims in respect of the estate of the deceased, who died on 25 March 2003, are required by the trustees, Ralph Christensen, Graeme Ernest Christensen and Diane Whitton, to send particulars of their claims to them care of the undersigned solicitors by 22 July 2003 after which date the trustees may convey or distribute the assets having regard only to the claims of which they then have notice.

GRAY FRIEND & LONG, solicitors,
70 Queen Street, Warragule 3820.

MARGARET JOYCE DENSLEY, late of Unit 6, 165 Princes Way, Drouin, widow, deceased. Creditors, next-of-kin and others having claims in respect of the estate of the deceased, who died on 22 February 2003, are required by the trustees, Bruce Murray Densley and Gregory Arthur Densley, to send particulars of their claims to them care of the undersigned solicitors by 22 July 2003 after which date the trustees may convey or distribute the assets having regard only to the claims of which they then have notice.

GRAY FRIEND & LONG, solicitors,
70 Queen Street, Warragule 3820.

FRANCA FARALLA, late of 45 Hudson Street, Fawkner 3060, in the State of Victoria, home duties, deceased. Creditors, next-of-kin and others having claims in respect of the estate of the abovenamed deceased, who died on 19 February 2003, are required by Giuseppina Callea, the administratrix of the said estate, to send particulars by 23 July 2003 to her solicitors, Gullaci & Gullaci of 158 Bell Street, Coburg, after which date the administratrix may

convey or distribute the assets, having regard only to the claims of which she then has notice.

Dated 13 May 2003

GULLACI & GULLACI, solicitors,
158 Bell Street, Coburg, Victoria 3058.

Creditors, next-of-kin and others having claims against the estate of JEAN PAYNE late of Unit 95, Oak Grange, 695 Hawthorn Road, East Brighton, Victoria, who died on 8 December 2002, are required by the executors, Marilyn Jean Payne of 34 Avocet Street, Doncaster East, Victoria, Carol Anne Notter of Unit 2, 32 Khartoum Road, Macquarie Park, New South Wales and Brian Burnan Payne of 4 Campbellfield Drive, Yarrowonga, Victoria, to send detailed particulars of their claims to the said executors, c/- Hassall & Byrne, solicitors of 250 Charman Road, Cheltenham 3192 by 22 July 2003 after which date they will proceed to distribute the said estate having regard only to the claims of which they then have notice.

HASSALL & BYRNE, solicitors,
250 Charman Road, Cheltenham 3192.

Re: FREDERICK TOURNIER, late of Grace McKellar Centre, 5 Peter Street, Grovedale, Victoria, deceased. Creditors, next-of-kin and others having claims in respect of the estate of the deceased, who died on 11 September 2002 at Grovedale, are required by the executor, Peter Charles Tournier of 3 Ashley Court, Grovedale, Victoria, the executor of the said deceased's Will dated 22 December 1960 and Codicil dated 16 November 2000, to send particulars to them care of the undermentioned solicitor by 30 July 2003 after which date the executor may convey or distribute the assets having regard only to the claims of which he then has notice.

IAN F. APTED, solicitor,
63 Yarra Street, Geelong 3220.

Re: GORDON RINGWOOD, deceased.

Creditors, next-of-kin and others having claims in respect of the estate of GORDON RINGWOOD, late of Stephenson's House, Gibb Street, Berwick, Victoria, deceased, who died on 27 January 2003, are to send particulars of their claims to the executor care of the undermentioned solicitors by 21 July 2003 after

which date the executor will distribute the assets having regard only to the claims of which the executor then has notice.

K. P. ABBOTT & CO., solicitors,
1628 High Street, Glen Iris 3146.

Creditors, next-of-kin and others having claims in respect of the estate of WILLIAM SMITH, late of 991 Mount Dandenong Tourist Road, Montrose, Victoria, gentleman, retired, deceased, who died on 3 April 2003, are required by the executor, Neville Denis Kelly of 437 Centre Road, Bentleigh, Victoria, to send particulars of such claims to the solicitors acting for the said executor, namely Kelly & Chapman of 437 Centre Road, Bentleigh, Victoria by 30 July 2003 after which date the said executor may convey or distribute the assets of the deceased, having regard only to the claims of which he or his solicitors then have notice.

KELLY & CHAPMAN, lawyers,
437 Centre Road, Bentleigh.

MATTHEW MAURICE O'SHEA, late of 220 Middleborough Road, Blackburn, Victoria, retired plumber, deceased. Creditors, next-of-kin and others having claims in respect of the estate of the deceased, who died on 9 February 2003, are required by the executors to send particulars to them care of the undermentioned solicitors by 20 July 2003 after which date the executors may convey or distribute the assets having regard only to the claims of which they then have notice.

LUCAS LAWYERS, solicitors,
8 Station Road, Cheltenham 3192.

Re: ANNEITA ELIZABETH CLAGNAN, late of 72 Blackwood Avenue, Mentone, Victoria, widow, deceased. Creditors, next-of-kin and others having claims in respect of the estate of the deceased, who died on 13 November 2002, are required by the executrix, Jennifer Susan Edsall, to send particulars to the solicitors for the estate, Messrs Lynch & MacDonald by 30 July 2003 after which date the executrix may convey or distribute the assets, having regard only to the claims of which the executrix then has notice.

LYNCH & MACDONALD, solicitors,
Suite 6, 412 Toorak Road, Toorak, Vic. 3142.

JOHN FRANCIS SCHRECK, late of 23A Tandarook Crescent, Donvale, Victoria, but formerly of 19 Munro Avenue, Mount Waverley, Victoria, carpenter, deceased. Creditors, next-of-kin and others having claims in respect of the estate of the deceased, who died on 22 February 2003, are required by the trustee, Phillip John Schreck (in the Will called Philip John Schreck) of 33 Oakdene Crescent, Carnegie, Victoria, audio technician/engineer, the son, to send particulars to the trustee by 22 July 2003 after which date the trustee may convey or distribute the assets, having regard only to the claims of which the trustee has notice.

MASON SIER TURNBULL, solicitors,
315 Ferntree Gully Road, Mount Waverley 3149.

Creditors, next-of-kin and others having claims in respect of the estate of AUSTIN MCKENZIE DICKMAN deceased, late of 59 Templeton Street, Wantirna, Victoria, retired accountant, who died on 10 May 2003, are required by the executor, ANZ Executors & Trustee Company Limited, (ACN 006 132 332) of 530 Collins Street, Melbourne, Victoria, to send particulars to it by 22 July 2003 after which date it may convey or distribute the assets having regard only to the claims of which it then has notice.

MILLS OAKLEY, lawyers,
121 William Street, Melbourne.

Re: JACK MUSTARD, late of 3 Cameron Street, Cann River, Victoria, retired. Creditors, next-of-kin and others having claims in respect of the estate of the deceased, who died on 15 October 2002, are required by Kaye Patricia Henderson of 17 Cameron Street, Cann River, Victoria, the executor appointed in the Will, to send particulars to her solicitor within sixty days from the date of publication of this notice, after which date the executor may convey or distribute the assets having regard only to the claims of which they then have notice.

MOSLEY & PALMER, solicitors,
PO Box 243, Orbest 3888.

JEANETTE LOUISE OKSANA
TOMASZEWSKI, late of 49 Cornwall Street, West Brunswick, Victoria, home duties,

deceased. Creditors, next-of-kin and others having claim in respect of the estate of the deceased, who died on 5 February 2003, are required by the executor, Marusia MacCormick, care of 180 Queen Street, Melbourne, Victoria, to send particulars to her by 23 July 2003 after which date she may convey or distribute the assets having regard only to the claims of which she then has notice.

NICHOLAS O'DONOHUE & CO., lawyers,
180 Queen Street, Melbourne 3000.

Re: JOHN PATRICK McNAMARA, late of Bethlehem Home for the Aged, Taylor Street, Golden Square, Victoria, retired teacher, deceased. Creditors, next-of-kin and others having claims in respect of the estate of the deceased, who died on 24 December 2002, are required by the trustee, Lawrence O'Farrell of corner McCrae & Mundy Streets, Bendigo, Victoria, solicitor, to send particulars to the trustee by 29 July 2003 after which date the trustee may convey or distribute the assets, having regard only to the claims of which the trustee has notice.

O'FARRELL ROBERTSON McMAHON,
solicitors,
Corner of McCrae & Mundy Streets,
Bendigo 3550.

Re: EDWARD HENRY TOVEY, late of Autumndale Lodge, 13 Eagland Road, Cheltenham 3192, Victoria, but formerly of Unit 5, 15 Heatherhill Road, Frankston 3199, Victoria, pensioner, deceased. Creditors, next-of-kin and others having claims in respect of the estate of the deceased, who died on 5 January 2003, are required by the trustee, John Edward Tovey of Flat 1, 321 Dandenong Road, Prahran, Victoria, information technology contractor, the son, to send particulars to the trustee by 1 August 2003 after which date the trustee may convey or distribute the assets, having regard only to the claims of which the trustee has notice.

PEARCE WEBSTER DUGDALES, solicitors,
24 High Street, Glen Iris 3146.

HILDA MAY ADAMS, late of 243 Balwyn Road, North Balwyn, Victoria. Creditors, next-of-kin and others having claims in respect

of the estate of the deceased, who died on 26 January 2003, are required by Perpetual Trustees Victoria Limited, ACN 004 027 258 of 360 Collins Street, Melbourne, Victoria to send particulars of their claims to the said company by 23 July 2003 after which date it will convey or distribute the assets having regard only to the claims of which the company then has notice.

MOLLIE ANNIE PYKE, late of Camberlea Private Nursing Home, 629 Riversdale Road, Camberwell, Victoria, formerly of 2/9 Tintern Avenue, Toorak, Victoria. Creditors, next-of-kin and others having claims in respect of the estate of the deceased, who died on 10 January 2003, are required by Perpetual Trustees Victoria Limited, ACN 004 027 258 of 360 Collins Street, Melbourne, Victoria (with leave reserved to Jonathan Phillip Rayman, the other executor appointed in the Will to come in and prove the same), to send particulars of their claims to the said company by 23 July 2003 after which date it will convey or distribute the assets having regard only to the claims of which the company then has notice.

Creditors, next-of-kin and others having claims in respect of the estate of MICHAEL SZYMANSKI, late of 7 Garden Avenue, East Brighton, in the State of Victoria, pensioner, deceased, who died on 28 April 2003, are required to send particulars of such claims to the executor care of the undermentioned solicitors by 21 July 2003 after which date the executor will convey or distribute the assets having regard only to the claims of which the executor then has notice.

PIETRZAK, solicitors,
222 La Trobe Street, Melbourne.

Creditors, next-of-kin and others having claims in respect of the estate of ZOFIA JANINA SALKOWSKI, late of 10 Woodlands Grove, Oakleigh, in the State of Victoria, pensioner, deceased, who died on 3 March 2003, are required to send particulars of such claims to the executors care of the undermentioned solicitors by 21 July 2003 after which date the executor will convey or distribute the assets having regard only to the claims of which the executor then has notice.

PIETRZAK, solicitors,
222 La Trobe Street, Melbourne.

BERENICE GHERA HARRIS, late of 449 Basalt Road, Basalt Hill, Victoria, retired architect, deceased. Creditors, next-of-kin and others having claims in respect of the estate of the deceased, who died on 23 June 2002, are required by the executors, Annette Zola Ratcliffe of 449 Basalt Road, Basalt Hill, Victoria, Barrie John Young of 431 Riversdale Road, Hawthorn East, Victoria and Catherine Mary Fry of 262 Macpherson Street, North Carlton, Victoria, to send particulars to them (care of the undersigned) by 22 July 2003 after which date the executors may convey or distribute the assets having regard only to the claims of which they then have notice.

RENNICK & GAYNOR, solicitors,
431 Riversdale Road, Hawthorn East.

IRIS BEVAN FOX, late of Unit 5, 32 Kenmare Street, Mont Albert, Victoria, gentlewoman, deceased. Creditors, next-of-kin and others having claims in respect of the estate of the deceased, who died on 15 January 2003, are required by the executors, Barrie John Young of 431 Riversdale Road, Hawthorn East, Victoria and Catherine Mary Fry of 262 Macpherson Street, North Carlton, Victoria, to send particulars to them care of the undersigned by 23 July 2003 after which date the executors may convey or distribute the assets having regard only to the claims of which they then have notice.

RENNICK & GAYNOR, solicitors,
431 Riversdale Road, Hawthorn East.

Creditors, next-of-kin or others having claims in respect of the estate of MARTIN RUZICKA, late of Warragaburra Farm, Trentham, Victoria, farmer, deceased, who died on 30 March 2002, are to send particulars of their claims to the executors care of the undermentioned solicitors by 24 July 2003 after which date the executors will distribute the assets having regard only to the claims of which the executors then have notice.

RIGBY COOKE, solicitors,
469 La Trobe Street, Melbourne 3000.

Re: OLIVE MARJORIE WEIR, also known as Marjorie Weir, late of 371 Manningham Road, Doncaster, Victoria, nurse, deceased.

Creditors, next-of-kin and others having claims in respect of the estate of the deceased, who died on 23 January 2003, are required by the trustee, Marjorie Jean Molloy of Lot 26, Axedale–Goornong Road, Axedale, Victoria, home duties, the daughter, to send particulars to the trustee by 30 July 2003 after which date the trustee may convey or distribute the assets, having regard only to the claims of which the trustee has notice.

RUSSO PELLICANO CARLEI, solicitors,
43 Atherton Road, Oakleigh 3166.

Re: KATHLEEN MARY HANNON, late of 15 Murphy Street, Brighton, Victoria, widow, deceased. Creditors, next-of-kin and others having claims in respect of the estate of the abovenamed deceased, who died on 4 March 2003, are required to send particulars of their claims to the executors, John Bernard Hannon and Paul Gerard Hannon, care of the undermentioned solicitors by 25 July 2003 after which date the said executors will distribute the assets having regard only to the claims of which they then have notice.

T. J. MULVANY & CO., solicitors,
2nd Floor, 51 Queen Street, Melbourne 3000.

Re: WAYNE NEIL DACEY, late of 2 Wattleree Walk, South Morang, Victoria. Creditors, next-of-kin and others having claims in respect of the estate of the deceased, who died on 29 July 2002, are required to send particulars of their claims to the administrator, C/- Wills & Probate Victoria – lawyers, GPO Box 1946, Melbourne 3001 by 4 August 2003 after which date the administrator may convey or distribute the assets having regard only to the claims of which she may then have notice.

WILLS & PROBATE VICTORIA, lawyers,
Level 5, 360 Little Collins Street, Melbourne.

Unclaimed Moneys Act 1962

Register of Unclaimed Moneys held by the —

<i>Name of Owner on Books and Last Known Address</i>	<i>Total Amount Due to Owner</i>	<i>Description Of Unclaimed Money</i>	<i>Date when Amount first became Payable</i>
CFS GANDEL RETAIL TRUST			
	\$		
Mr John Moir Alexander, 20 Seaview Street, Blairgowrie	443.00	Cheque	26/02/01
Argold Pty Ltd, 60 Kooyong Road, Armadale	806.69	"	27/08/01
Argold Pty Ltd, 60 Kooyong Road, Armadale	788.36	"	26/02/01
Mrs Philippa Jennifer Arkles, 35 Oswald Street, Elsternwick	430.00	"	"
Mrs Helen Margaret Baker, C/- Ms W. Baker, F3 16 Devonshire Place, Kemp Town, Brighton BN2 1AQ, England, UK	164.56	"	27/08/01
Mrs Helen Margaret Baker, C/- Ms W. Baker, F3 16 Devonshire Place, Kemp Town, Brighton BN2 1AQ, England, UK	160.07	"	26/02/01
Mr John Bennett, 12/56 Anzac Parade, Kensington, NSW	440.00	"	27/08/01
Mr Glenn Bermingham, 6 Rowland Street, Mont Albert	440.00	"	"
Mr Glenn Bermingham, 6 Rowland Street, Mont Albert	430.00	"	26/02/01
Audrey Gillian Bunning, 203-233 New South Head Road, Edgecliff, NSW	1,813.00	"	27/08/01
Audrey Gillian Bunning, 203-233 New South Head Road, Edgecliff, NSW	1,772.00	"	26/02/01
Estate Late Nell Elizabeth A. Cooper, C/- Middletons Moore & Bevins, GPO Box 4388QQ, Melbourne	131.45	"	"
Ms Kerry Margaret Crowley, 7 Johnson Court, Kilmore	221.76	"	27/08/01
Mrs Jacqueline S. Czislowski, 1/6 Grange Road, Toorak	528.00	"	"
Mrs Jacqueline S. Czislowski, 1/6 Grange Road, Toorak	516.00	"	26/02/01
Daltree Pty Ltd, 16 Gilliver Avenue, Vaucluse, NSW	602.00	"	"
Mrs Patricia May Daly, Mount Eliza Terraces, 7/2 Mount Eliza Way, Mount Eliza	516.00	"	"
Darren Sheens Holdings Pty Ltd, "Darren Sheens Family A/c", PO Box 6410, Parramatta, NSW	336.60	"	27/08/01
Mrs Phyllis Elsie Doig, RMB 8125, Agar Road, Bass	170.83	"	26/02/01
Mr Norman Fong, 7 Jessica Close, Wantirna South	351.95	"	"
Mrs Margaret Evelyn Forrest, 130 High Street, Mansfield	262.81	"	"
Gev Investments Pty Ltd, "GLMFamily A/c", Flat 1, 526 Toorak Road, Toorak	774.00	"	"
Mr Denis Vincent Gordon & Mrs Maxine Valerie Gordon, PO Box 380, Glen Waverley	396.00	"	27/08/01
Mrs Susan Ann Gorman, 'Koolaman', Balranald, NSW	161.39	"	"
Mrs Shirley Jacqueline Hudson, 52 Shasta Avenue, East Brighton	1,320.00	"	"
Kija Pty Ltd, "Kija Superannuation Account", PO Box 458, Lavington, NSW	440.00	"	"
Dr David Thomas Kings, 50 Fawkner Street, South Yarra	165.92	"	"
Dr David Thomas Kings, 50 Fawkner Street, South Yarra	162.15	"	26/02/01
Ms Jennifer Maree Kruss, 5 James Cook Dr, Kewarra Beach, Qld	132.00	"	27/08/01
Mr William Alexander Meyer, 55 Lee Road, Winmalee, NSW	172.00	"	"

Namberry Willows Pty Ltd, Suite 3, 368 Hawthorn Road, Caulfield	656.99	''	''
Mrs Lynn Andrea Pendlebury, Unit 1, 4 View Street, Chatswood, NSW	132.00	''	27/08/01
Mrs Lynn Andrea Pendlebury, Unit 1, 4 View Street, Chatswood, NSW	129.00	''	26/02/01
Mr John Peter Roberts & Mrs Mary Angela Roberts, 30 Paxton Street, East Malvern	172.00	''	''
Mr Trevor Lane Teale, 12 Longbourne Avenue, Notting Hill	616.00	''	27/08/01
Mr Trevor Lane Teale, 12 Longbourne Avenue, Notting Hill	602.00	''	26/02/01
Miss Alma Mary Wilson, Unit 1, 435 Camberwell Road, Camberwell	656.99	''	''
Ms Jacklyn Elizabeth Yowell, 37 Goodwin St, Glen Iris	967.50	''	''

03091

CONTACT: ELAINE HARE, PHONE: (03) 9611 5714.

Unclaimed Moneys Act 1962

Register of Unclaimed Moneys held by the —

<i>Name of Owner on Books and Last Known Address</i>	<i>Total Amount Due to Owner</i>	<i>Description Of Unclaimed Money</i>	<i>Date when Amount first became Payable</i>
BRAMTON PTY LTD			
	\$		
P. & F. Tunjic, 57 Ocean Street, Rosebud	203.12	Cheque	05/02/99
T. Sullivan, 5 Woodside Close, Somerville	258.88	''	07/07/00
D. Riley, 14 Graeme Street, Dromana	203.12	''	13/01/99

03196

CONTACT: JOHN LEGGETT, PHONE: (0417) 884 859.

Unclaimed Moneys Act 1962

Register of Unclaimed Moneys held by the —

<i>Name of Owner on Books and Last Known Address</i>	<i>Total Amount Due to Owner</i>	<i>Description Of Unclaimed Money</i>	<i>Date when Amount first became Payable</i>
QUINN & QUINN			
	\$		
John Fraser, 12/66–68 Murray Street, Preston	175.00	Cheque	31/08/98

03135

CONTACT: MARY LAMBERT, PHONE: (03) 9592 3477.

Unclaimed Moneys Act 1962

Register of Unclaimed Moneys held by the —

<i>Name of Owner on Books and Last Known Address</i>	<i>Total Amount Due to Owner</i>	<i>Description Of Unclaimed Money</i>	<i>Date when Amount first became Payable</i>
CPI GROUP LIMITED			
	\$		
Mrs Norah Brown, 37 Cameron Street, Wauchope, NSW	1,142.64	Cheque	02/01/01
Mr Donald William Curson, Unit 144, 12 Commodore Drive, Paradise Waters, Qld	100.00	"	30/03/01
ESP Nominees Pty Ltd, "Yorke Super Fund A/c", (Liquidator Appointed) C/- Vouris And Bell, GPO Box 4453, Sydney, NSW	331.20	"	31/12/01
ESP Nominees Pty Ltd, "Yorke Super Fund A/c", (Liquidator Appointed) C/- Vouris And Bell, GPO Box 4453, Sydney, NSW	331.20	"	29/06/01
Gas Strategies Pty Ltd, "Superannuation Fund A/c", GPO Box 2355, Adelaide, SA	2,539.20	"	31/12/01
Mr Bruce R. J. Hallows, 11th Level, 469 La Trobe Street, Melbourne	200.00	"	30/03/01
Mr John Hunt & Mrs Suzanne Hunt, "Hunt Super Fund A/c", C/- Reward Management Aust P/L, PO Box N316, Grosvenor Place, NSW	761.76	"	31/12/01
Mr John Hunt & Mrs Suzanne Hunt, "Hunt Super Fund A/c", C/- Reward Management Aust P/L, PO Box N316, Grosvenor Place, NSW	761.76	"	02/01/01
Hydraulic Hardware Australia Pty Ltd, "Hydraservice Superfund A/c", C/- Reward Management Aust P/L, PO Box N316, Grosvenor Place, NSW	905.28	"	"
Mr Andreas Konig, C/- The Company Secretary, Consolidated Paper Industries (Holdings) Limited, 41-45 Mills Road, Braeside	500.00	"	30/03/01
Mr John Weston Seaforth MacKenzie, "SCK Super Fund No 2 A/c", PO Box 1731, Nort Sydney DC, NSW	518.88	"	31/12/01
Estate Late Shirley Jean McCormack, C/- Mr J. McCormack, PO Box 328, Kingsgrove, NSW	153.13	"	"
Mr Steven Minton & Mrs Shirlene Minton, "Minton Super Fund A/c", 58 Beresford Road, Lilydale	305.00	"	30/03/01
Mr Steven Minton & Mrs Shirlene Minton, "Minton Super Fund A/c", 58 Beresford Road, Lilydale	537.50	"	"
P. Petersen & Associates Pty Ltd, "Super Fund A/c", PO Box 2015, FVBC, Fortitude Valley, Qld	100.00	"	"
Mr Alar Raam, PO Box 1065, Cronulla, NSW	441.60	"	31/12/01
Mr Alar Raam, PO Box 1065, Cronulla, NSW	441.60	"	29/06/01
Estate Late Beverly Claire Richardson, C/- Cornwall Stodart Lawyers, Level 9, 179 Elizabeth Street, Sydney, NSW	150.00	"	30/03/01

Mr Peter James Roebig & Mr Gerald John Meyn & Mr Colin John Crow, "Sabae Super Fund A/c", 4 Cochrane Street, Paddington, Qld	220.80	"	31/12/01
Mr Anthony John Smith, PO Box R343, Royal Exchange, NSW	180.00	"	30/03/01
Vivel Pty Ltd, 9/43 Rockley Road, South Yarra	250.00	"	"
Mr Christopher Whatmore & Mrs Dulcie Whatmore, 21 Lindrum Road, Frankston	100.00	"	"
Mrs Elizabeth Kathleen Young, 80 Cliff Avenue, Northbridge, NSW	5,520.00	"	29/06/01

03085

CONTACT: ELAINE HARE, PHONE: (03) 9611 5714.

Unclaimed Moneys Act 1962

Register of Unclaimed Moneys held by the —

<i>Name of Owner on Books and Last Known Address</i>	<i>Total Amount Due to Owner</i>	<i>Description Of Unclaimed Money</i>	<i>Date when Amount first became Payable</i>
SUMMIT			
	\$		
Harold George & Eileen Mary Smith, PO Box 38, Ayr, Qld 4807	2,000.00	Cheque	14/01/00
Simon Matthew Chitarra, 63 Main Street, Osborne Park, WA	800.00	"	27/12/00

03199

CONTACT: THARANGA DE SILVA, PHONE: (03) 9618 4418.

Unclaimed Moneys Act 1962

Register of Unclaimed Moneys held by the —

<i>Name of Owner on Books and Last Known Address</i>	<i>Total Amount Due to Owner</i>	<i>Description Of Unclaimed Money</i>	<i>Date when Amount first became Payable</i>
CITY OF STONNINGTON			
	\$		
Sunbury Radiology, PO Box 367, Sunbury	101.30	Cheque	23/05/01

03136

CONTACT: PETER LIU, PHONE: (03) 8290 1227.

Unclaimed Moneys Act 1962

Register of Unclaimed Moneys held by the —

<i>Name of Owner on Books and Last Known Address</i>	<i>Total Amount Due to Owner</i>	<i>Description Of Unclaimed Money</i>	<i>Date when Amount first became Payable</i>
CSL LIMITED			
	\$		
Altania Pty Limited, C/- Barry Mendel Frank & Co Services Pty Limited, Level 53, MLC Centre, Martin Place, Sydney, NSW	1,700.00	Cheque	11/10/01
Altania Pty Limited, C/- Barry Mendel Frank & Co Services Pty Limited, Level 53, MLC Centre, Martin Place, Sydney, NSW	900.00	"	25/04/01
Mr Richard Siong-Min Ang & Mrs Margaret Fong May Ang, 188 Albert Avenue, Boronia	170.00	"	11/10/01
Mrs Stella Gabriel Arthur, 38 Coolabah Ave, Sandy Bay, Tas.	180.00	"	25/04/01
A. S. Nominees Limited, "Tearle S/F A/c", GPO Box 1906, Canberra, ACT	180.00	"	"
Mr Con Aspros & Mrs Sophie Aspros, 8 Brookland Grove, Thomastown	170.00	"	11/10/01
Mr Ronald Atterton & Mrs Christine Atterton, 24 Flaxman Street, Port Lincoln, SA	180.00	"	25/04/01
AVM Appointees Pty Limited, "AVM Fund A/c", 2 Cumbee Lane, Caringbah, NSW	315.00	"	"
Mr Graeme Robert Baker, 6 Belmont Street, Belmont	170.00	"	11/10/01
Mr Andrew John Benston, RMB 4035, Yea	170.00	"	"
Mrs Sunita Bhargava & Ms Sugandha Bhargava & Ms Manisha Bhargava, 16 Jedem Close, Viewbank	127.50	"	"
Dr David Bornstein, 237 Kooyong Road, Elsternwick	612.00	"	"
Dr David Bornstein, 237 Kooyong Road, Elsternwick	324.00	"	25/04/01
Estate Late Margaret P. Bowering & Dr Douglas Charles Bowering, C/- John B. Pridham, PO Box 3048, Norwood, SA	340.00	"	11/10/01
Mr Peter Michael Bradley, 38 Queen Street, Unley, SA	151.13	"	"
Cascar Pty Limited, 26 Nithsdale Street, Sydney, NSW	266.05	"	"
Cascar Pty Limited, 26 Nithsdale Street, Sydney, NSW	140.85	"	25/04/01
Mrs Marina Gaye Chang, PO Box 154, Glenhuntly	170.00	"	11/10/01
Mr Michael Chen, PO Box 352, Bulleen	180.00	"	25/04/01
Mrs Lucy Cheong, 1402/2 Marcus Clarke Street, Capital Tower, Canberra City, ACT	170.00	"	11/10/01
Mr Robin Leonard Ching, 22 Boxhill Khandallah, Wellington 4, New Zealand	180.00	"	25/04/01
Mrs Pauline B. Clarke, 18 Fairy Street, Ivanhoe	139.57	"	11/10/01
Est Mr Raymond Richard Clarke, 123 Bagnall Street, Ellen Grove, Qld	510.00	"	"
Mr Paul Robert Comino, 4 Igerne Court, Carindale, Qld	170.00	"	"
Mrs Myrna Mary Campbell-Cowan, 20 Stodart St, Camberwell	170.00	"	"

Mr Peter Joseph Cox, 42 Bourke Street, Reservoir	180.00	''	25/04/01
Mr Peter Joseph Cox, 20 Ross Street, Port Melbourne	340.00	''	11/10/01
David Hocking Pty Ltd, 320 Square Connection, Bankstown, NSW	680.00	''	''
Mrs Kerrie Verlie Davis, PO Box 76, Narrandera, NSW	170.00	''	''
Mr Lloyd Samuel Davis, "L S Davis Family A/c", 15 St James Park Drive, Brighton	340.00	''	''
Mrs Gwenda Anne Deacon, 261 Gooch Street, Thornbury	170.00	''	''
Dr Robert Frans H. Dekker & Dr Leila Maria Dekker, 4 Blackbutt Way, Canningvale, WA	170.00	''	''
Dicanco Nominees Pty Ltd, "SJRSF A/c", Level 29, 264-278 George Street, Sydney, NSW	170.00	''	''
Estate Late Gwendoline Alice Margaret Donald & Mr Peter William Donald, "Felix Sameli Joynt A/c", 12 Beach Road, Hampton	133.45	''	''
Mr Sheng Yao Dong & Ms Ya Fang Ding, PO Box 482, Campsie, NSW	127.50	''	''
Mr Vincent Anthony Doquile, 128 Mont Albert Road, Canterbury	340.00	''	''
Mr Vincent Anthony Doquile, 128 Mont Albert Road, Canterbury	180.00	''	25/04/01
Mr Eric Peter Dystelblom, 8/21 Wells Road, Seaford	340.00	''	11/10/01
Eromoba Pty Ltd, 13B Hunter Street, Richmond	119.00	''	''
Mr Corrado Ferella & Ms Isabella Ferella, 9 Alma Road, Bundoora	170.00	''	''
Mr Neil Alexander Firth, PO Box 9, Hahndorf, SA	170.00	''	''
Mr Glenn Fowler & Mr Richard Thame & Mr Aran Flanagan, 2 Wentworth Street, Croydon Park, NSW	136.00	''	''
Mr Ernest Frederick, "Super Fund A/c", 228 Malvern Road, Prahran	510.00	''	''
Mr Ernest Frederick, "Super Fund A/c", 228 Malvern Road, Prahran	270.00	''	25/04/01
Mr Phillip Anthony Fricke, PO Box 4121, Mildura	170.00	''	11/10/01
Mrs Janette Anne Furniss, 29 Flinders Ave, Kingscote, SA	170.00	''	''
Mrs Sheila Maguire Greenway, 95 Indian Avenue, Middletown RI 02842, USA	103.50	''	25/04/01
Mr Robert John Hall, 161 Pickles Street, Port Melbourne	141.27	''	11/10/01
Mrs Kathryn Ann Harrod, 43 Margaret St, Toowoomba, Qld	340.00	''	''
Ms Kate Hilderbrand, 41 Cratloe Road, Mount Waverley	119.00	''	''
Mr James Anthony Hirjee & Ms Judith Lesley Hirjee, 58 Bass Street, Barrack Heights, NSW	360.00	''	25/04/01
Mr Benjamin Antony Holland, 2 Buley St, East Hawthorn	170.00	''	11/10/01
Dr Magda Horvat, Unit 6, 316 Wattletree Road, Malvern East	225.00	''	25/04/01
Hwa-Fen Hsu, 2A Waratah Street, Chatswood, NSW	170.00	''	11/10/01
Mrs Lilian Bereford Huenerbein, RMB 13, Bathurst Road, Orange, NSW	680.00	''	''
Mrs Lilian Bereford Huenerbein, RMB 13, Bathurst Road, Orange, NSW	360.00	''	25/04/01
Ian Vining Limited, PO Box 31, 358 Milford, Auckland, New Zealand	153.00	''	11/10/01
Janatos Pty Ltd, "Superannuation Fund A/c", 130 Beecroft Road, Beecroft, NSW	510.00	''	''

Janatos Pty Ltd, "Superannuation Fund A/c", 130 Beecroft Road, Beecroft, NSW	270.00	"	25/04/01
Mrs Helen Jones, 35 Uvadale Grove, Kew	102.00	"	11/10/01
J. R. Heaps Pty Ltd, "Superannuation Fund A/c", 3 Puie Street, Bundaberg, Qld	360.00	"	25/04/01
Mrs Margaret Evelyn Kamensky, 51 Coleman Road, Wantirna South	170.00	"	11/10/01
Mr Wai Fai Kan, 10 Second Avenue, Eastwood, NSW	1,785.00	"	"
Mr Wai Fai Kan, 10 Second Avenue, Eastwood, NSW	945.00	"	25/04/01
Mr Peter Sam Kazacos, 7 Pardey Street, Kingsford, NSW	102.00	"	11/10/01
Mr David John Eric Keuneman, 42 Arthur Street, Fairfield	204.00	"	"
Mr David John Eric Keuneman, 42 Arthur Street, Fairfield	108.00	"	25/04/01
Dr Johannes Khor, 855 Toorak Road, Hawthorn East	238.00	"	11/10/01
Mrs Shirley Anne Lander, 314 Currie Crescent, Kingston, ACT	136.00	"	"
Mr Michael Andrew Lange, 31 Dellar Street, Narrogin, WA	166.60	"	"
Ms Moira Laverty, 81 Upper Fitzroy Cres, South Hobart, Tas.	170.00	"	"
Miss Gwendolyn Lee, Flat 4, 4 Clowes Street, South Yarra	170.00	"	"
Mr Basil Lenzo, Unit 1, 8 Parker Street, South Perth, WA	180.00	"	25/04/01
Mr Kok Tee Lim, C/- K P M G Peat Marwick, GPO Box 2975EE, GPO Melbourne	170.00	"	11/10/01
Dr Kit-Peng Loke, 9 Salisbury Avenue, Mont Albert	170.00	"	"
Mr John Lontos, 116 Burrowye Crescent, Keilor	151.13	"	"
Mr Siek Foong Low, PO Box 334, Blacktown, NSW	170.00	"	"
Mr David Edward Lowe, 23 Chapman Ave, Beecroft, NSW	170.00	"	"
Mr Ernest Saronga Massawe, PO Box 2475, Dar Es Salaam, Tanzania	170.00	"	"
Mr Kerry Noel McIlwraith & Mrs Marie Claire McIlwraith, 230 Old Gold Mines Road, Sutton, NSW	180.00	"	25/04/01
Mrs Anne Shirley McNeill, 1 Kythira Street, Sunnybank, Brisbane, Qld	170.00	"	11/10/01
Mr Laurent Perez-McVie, 2 Kim Street, Gladesville, NSW	131.75	"	"
Mitchell Papantoniou and Associates Pty Ltd, "Papantoniou Super Fund A/c", 2 Halley Ave, Bexley, NSW	425.00	"	"
Mitchell Papantoniou and Associates Pty Ltd, "Papantoniou Super Fund A/c", 2 Halley Ave, Bexley, NSW	225.00	"	25/04/01
Mrs Annis Gwen Nichilson & Mr Derek John Villeneuve Nicholson, 4/57 Bellevue Terrace, Clayfield, Qld	170.00	"	11/10/01
Northwest Homes Pty Ltd, "Northwest Super Fund A/c", PO Box 36, Nichols Point	340.00	"	"
Mr Frank Bernard O'Keefe, "Superannuation A/c", 37 Inkerman Street, Maryborough	340.00	"	"
Kim Sye Ong, 1402/2 Marcus Clarke Street, Capital Tower Canberra City, ACT	170.00	"	"
Ms Marjorie Orr, 890 Glenferrie Road, Kew	765.00	"	"
Mrs Tracey Joanne Osborne, 22 Robb Street, Essendon	170.00	"	"
Mr Peter Clifford Patrick, 84A Wyralla Ave, Epping, NSW	270.00	"	25/04/01
Mr Mark Allan Patton & Mrs H. Lois Patton, 29 Crocus Way, Ferndale, WA	340.00	"	11/10/01
Mr Mark Allan Patton & Mrs H. Lois Patton, 29 Crocus Way, Ferndale, WA	180.00	"	25/04/01
Mr Michael Pelling, 28 Laura Street, Moonee Ponds	187.00	"	11/10/01

Mr John William Pike, 11 Bronwyn Street, Bracken, Qld	306.00	''	25/04/01
Mr Peter Pryles, C/- 2/377 Lonsdale Street, Melbourne	170.00	''	11/10/01
Peter James Roebig & Gerald John Meyn & Colin John Crow, "Saubae Superannuation A/c", 4 Cochrane Street, Paddington, Qld	110.50	''	11/10/01
Ross Management Pty Ltd, "Ross Superannuation Fund A/c", 2 Blackwood Avenue, Clovelly, NSW	170.00	''	''
Rotem Pty Ltd, "The MB Family Fund A/c", 57 York Street, St Kilda West	1,156.00	''	''
Rotem Pty Ltd, "The MB Family Fund A/c", 57 York Street, St Kilda West	612.00	''	25/04/01
Mr Cornelius Patrick Ryan, 194 Ewos Parade, Cronulla, NSW	510.00	''	11/10/01
Mr John Adrian Sambell & Mrs Rosemarie Sambell, 11 Wilson Street, Glen Iris	510.00	''	''
Mr Edward Douglas Sarah, "Superannuation Fund A/c", 67 St Georges Rd, Elsternwick	510.00	''	''
Shearwater International Pty Ltd, "Chattan Family A/c", PO Box 736, Brisbane, Qld	102.00	''	''
Simzam Nominees Pty Ltd, Unit 9A, 9 Beach Street, Port Melbourne	153.00	''	''
Mr Satnam Singh, 60 Arafura St, Upper Mount Gravatt, Qld	164.90	''	''
SJMS Nominees Pty Ltd, 174 Phillip Street, Sydney, NSW	238.00	''	''
SJMS Nominees Pty Ltd, 174 Phillip Street, Sydney, NSW	126.00	''	25/04/01
Mr Brendan Scott Smale, 33 High Street, Woodend	139.57	''	11/10/01
Ms Janice May Smart, 48 Martin Road, Glen Iris	170.00	''	''
Mr Sidney Edward Smith, 24 Woodend Road, Ipswich, Qld	170.00	''	''
Mr George Ronald Smyth, 13 Vears Road, Ashburton	180.00	''	25/04/01
Mr Richard Keith Solly, 16 Ailsa Street, Ascot Vale	595.00	''	11/10/01
Mrs Mary Helena Stark, PO Box 345, Sarina, Qld	612.00	''	''
Mrs Mary Helena Stark, PO Box 345, Sarina, Qld	324.00	''	25/04/01
Mr Ian Stevenson & Mrs Jennifer Leslie Stevenson, C/- K R Securities Pty Ltd, PO Box 34, Greenslopes, Qld	144.50	''	11/10/01
Mr Robin Stewart, PO Box 149, Greenpoint 8051, Cape Town, South Africa	108.00	''	25/04/01
Mrs Eustace Suzanne, PO Box 1354 Bowral, NSW	170.00	''	11/10/01
Mr William Kwok Hung Tam, PO Box 428, Strathfield, NSW	170.00	''	''
Mr Kenneth Tang, 24 Barry Coe Place, Mount Pleasant, NSW	340.00	''	''
Mr Kenneth Tang, 24 Barry Coe Place, Mount Pleasant, NSW	180.00	''	25/04/01
Mrs Malti Thakkar, 129 Longfield Street, Cabramatta, NSW	340.00	''	11/10/01
Mrs Anne Thong, 59 Orchard Street, Syndal	340.00	''	''
Mrs Anne Thong, 59 Orchard Street, Syndal	180.00	''	25/04/01
Mr Allan L. Trethewey, "West Nombi" Village, Mullaley, NSW	510.00	''	11/10/01
Mr John Joseph Trost, 24 Fitzgibbon Crescent, North Caulfield	170.00	''	''
Miss Michelle Tsui, 2nd Floor, 333 Flinders Lane, Melbourne	170.00	''	''
Mr Peter Isf Vince, 40 Cook Road, Killara, NSW	510.00	''	''
Ms Tania Viskovich, 15/76 Campbell Parade, Bondi Beach, NSW	340.00	''	''
Ms Tania Viskovich, 15/76 Campbell Parade, Bondi Beach, NSW	180.00	''	25/04/01
Ms Sonali Viswasam, 110 Fragar Road, Penrith, NSW	102.00	''	11/10/01

Mr Noel David Wendt, "Wendt Super Fund A/c", 3 Candlebrook Quadrant, Rowville	170.00	"	"
Mr Stephen George Western & Mrs Gwendoline Western & Mr Peter James Western & "The Western Family Account", 1 James Court, Leongatha	340.00	"	"
Mrs Phyllis May Westphalen, 34 Parklands Terrace, Beachport SA	170.00	"	"
Mrs Jill Frances White, 94 Liverpool Street, Paddington, NSW	107.10	"	"
Mrs Deirdre Mignon Wilson, 59 Brownville Crescent, Maori Hill, Dunedin, New Zealand	225.00	"	25/04/01
Mr Scott Alan Wilson, 4 Duke Place, Balmain East, NSW	170.00	"	11/10/01
Mr William Ian Wilson, 14/17 Como Avenue, South Yarra	170.00	"	"
Mrs Anne Margaret Woulfe, 2 Jane Street MacAndrew Bay, Dunedin, New Zealand	263.50	"	"
X-Clone Pty Limited, C/- KPMG Attn: Mr D. J. Van Homrigh, GPO Box 223, Brisbane, Qld	170.00	"	"
Ms Moh Har Yip, 4 Pinaroo Place, Lane Cove, NSW	340.00	"	"
Ms Moh Har Yip, 4 Pinaroo Place, Lane Cove, NSW	180.00	"	25/04/01
Mrs Shirley Sam Yue, Flat 32, 333 Bulwara Road, Ultimo, NSW	187.00	"	11/10/01
Zechariah Pty Ltd, "Retirement Fund A/c", Level 12, 55 Clarence Street, Sydney, NSW	340.00	"	"

03087

CONTACT: ELAINE HARE, PHONE: (03) 9611 5714.

Unclaimed Moneys Act 1962

Register of Unclaimed Moneys held by the —

<i>Name of Owner on Books and Last Known Address</i>	<i>Total Amount Due to Owner</i>	<i>Description Of Unclaimed Money</i>	<i>Date when Amount first became Payable</i>
DIVERSIFIED UNITED INVESTMENT LTD			
\$			
Mr Ken Hunt, 92 Dexter Street, Cook, ACT	262.50	Cheque	20/06/01
Mrs Margaret Mary Mansour, 16 Foote Street, Brighton	187.50	"	11/04/01
Anthony Michael Sciuto, C/- Tower Trust Ltd, GPO Box 546, Adelaide, SA	314.06	"	20/06/01
Anthony Michael Sciuto, C/- Tower Trust Ltd, GPO Box 546, Adelaide, SA	209.38	"	11/04/01

03088

CONTACT: ELAINE HARE, PHONE: (03) 9611 5714.

Unclaimed Moneys Act 1962

Register of Unclaimed Moneys held by the —

<i>Name of Owner on Books and Last Known Address</i>	<i>Total Amount Due to Owner</i>	<i>Description Of Unclaimed Money</i>	<i>Date when first became Payable</i>
GUNNS LIMITED			
	\$		
Archer Holdings Pty Ltd, "The Tiwi A/c", PO Box 292, Frenchs Forest, NSW	640.00	Cheque	29/10/01
Miss Enid Mona Campbell, Faculty of Law, Monash University, PO Box 92, Clayton	512.16	"	"
Miss Enid Mona Campbell, Faculty of Law, Monash University, PO Box 92, Clayton	512.16	"	27/04/01
Miss Enid Mona Campbell, Faculty of Law, Monash University, PO Box 92, Clayton	896.28	"	06/06/01
Mr Michael Adnam Coffey, 11 Marlborough Place, St Ives, NSW	600.00	"	29/10/01
Mr Michael John Crisp & Mr Andrew Alan Crisp & Mrs Phillipa Mary Ditcham, 64 Walana Street, Geilston Bay, Tas.	256.32	"	"
Mr Michael John Crisp & Mr Andrew Alan Crisp & Mrs Phillipa Mary Ditcham, 64 Walana Street, Geilston Bay, Tas.	256.32	"	27/04/01
Mr Michael John Crisp & Mr Andrew Alan Crisp & Mrs Phillipa Mary Ditcham, 64 Walana Street, Geilston Bay, Tas.	448.56	"	06/06/01
Mr Hugo Robert Graves, 48 Stevenson Street, Kew	200.00	"	29/10/01
Mrs Noela Marie Hayes, 15 May Street, Kangaroo Flat	1,080.00	"	"
Mr William Patrick Beresford Irwin, 491 Nicholson Street, Carlton North	200.00	"	"
Mrs Elizabeth Kurtukoff, 30 Osborne Ave, Trevallyn, Tas.	152.46	"	06/06/01
Estate Late Wilfred John Louis Manthei, C/-Tasmanian Permanent Executors, PO Box 286C, Launceston, Tas.	427.20	"	29/10/01
Estate Late Wilfred John Louis Manthei, C/-Tasmanian Permanent Executors, PO Box 286C, Launceston, Tas.	256.32	"	27/04/01
Estate Late Wilfred John Louis Manthei, C/-Tasmanian Permanent Executors, PO Box 286C, Launceston, Tas.	747.60	"	06/06/01
Mr Richard Millar, Bealah Gardens, Launceston, Tas.	422.16	"	29/10/01
Pacific Highway Pty Ltd, Level 23, 1 Alfred Street, Sydney, NSW	3,120.00	"	"
Fr Richard Peter Ross, PO Box 152, Mowbray Heights, Tas.	120.00	"	"

Est Mrs Nisca May Sutherland, C/- Walters Solicitors, PO Box 562, Lismore, NSW	400.00	''	''
Mr Robert Henry Sutherland, 18 Cypress Gardens, Ballina Rd, Alstonville, NSW	400.00	''	''
Mr Stuart Ross Taylor, Junction Farm, PO Box 3, Hadspen, Tas.	120.00	''	''
Mr Stuart Ross Taylor, Junction Farm, PO Box 3, Hadspen, Tas.	120.00	''	27/04/01
Mr Stuart Ross Taylor, Junction Farm, PO Box 3, Hadspen, Tas.	210.00	''	06/06/01
Mr Michael Woods, 4 East Barrack Street, Deloraine, Tas.	120.00	''	29/10/01
Mr Michael Woods, 4 East Barrack Street, Deloraine, Tas.	120.00	''	27/04/01
Mr Michael Woods, 4 East Barrack Street, Deloraine, Tas.	210.00	''	06/06/01

03096
CONTACT: ELAINE HARE, PHONE: (03) 9611 5714.

Unclaimed Moneys Act 1962

Register of Unclaimed Moneys held by the —

<i>Name of Owner on Books and Last Known Address</i>	<i>Total Amount Due to Owner</i>	<i>Description Of Unclaimed Money</i>	<i>Date when Amount first became Payable</i>
MALLESONS STEPHEN JAQUES			
	\$		
Johannes Dicky Goestiawan, 6 Albany Road, Toorak	100.00	Cheque	29/07/98
Shaiky Moosa	450.00	''	08/03/02

03190
CONTACT: GREG SCHMIDT, PHONE: (03) 9643 5513.

Unclaimed Moneys Act 1962

Register of Unclaimed Moneys held by the —

<i>Name of Owner on Books and Last Known Address</i>	<i>Total Amount Due to Owner</i>	<i>Description Of Unclaimed Money</i>	<i>Date when Amount first became Payable</i>
EQUITY TRUSTEES LIMITED			
	\$		
Miss Maria Cooper, 433 Corbett Street, San Francisco, California 94114, USA	414.80	Cheque	18/06/01
Mr Leonard Phillips Fox, 10 Little Surrey Street, Potts Point, NSW	3,838.40	''	''

Mr Christopher Matthew Lines, 20 Renown Avenue, Tranmere, SA	143.20	''	''
Mr William Michael MacGregor, C/- 6 West Common Close, Gerrads Cross, Buckinghamshire SL9 7QR, United Kingdom	347.40	''	15/11/01
Mr William Michael MacGregor, C/- 6 West Common Close, Gerrads Cross, Buckinghamshire SL9 7QR, United Kingdom	347.40	''	05/04/01
Mr William Michael MacGregor, C/- 6 West Common Close, Gerrads Cross, Buckinghamshire SL9 7QR, United Kingdom	694.80	''	18/06/01
Mrs Audrey Phillipa Orr, Unit 2, 16 Clifton Street, Hawthorn	382.40	''	05/04/01
Mrs Jessie Wilson Parks, 9 Belmont Avenue, Balwyn	200.00	''	15/11/01
Mr Kenneth David Steel, 42 Albany Crescent, Surrey Hills	100.00	''	''
Mr Kenneth David Steel, 42 Albany Crescent, Surrey Hills	100.00	''	05/04/01
Mr Kenneth David Steel, 42 Albany Crescent, Surrey Hills	200.00	''	18/06/01
Estate Late Forster B. Weeks, C/- Public Trustees NSW, GPO Box 7, Sydney, NSW	290.40	''	15/11/01
Estate Late Forster B. Weeks, C/- Public Trustees NSW, GPO Box 7, Sydney, NSW	290.40	''	05/04/01
Estate Late Forster B. Weeks, C/- Public Trustees NSW, GPO Box 7, Sydney, NSW	580.80	''	18/06/01
Mrs Adrienne Joan Woodcroft, 39/59 Wrights Road, Drummoyne, NSW	400.00	''	05/04/01
Woondooma Pty Ltd, C/- Mrs Elaine Howden, PO Box 5262, Middle Park	400.00	''	18/06/01

03090

CONTACT: ELAINE HARE, PHONE: (03) 9611 5714.

Unclaimed Moneys Act 1962

Register of Unclaimed Moneys held by the —

<i>Name of Owner on Books and Last Known Address</i>	<i>Total Amount Due to Owner</i>	<i>Description Of Unclaimed Money</i>	<i>Date when Amount first became Payable</i>
EAST AFRICAN COFFEE PLANTATIONS LIMITED			
	\$		
Mrs Jean E. Boulton, Unit 4, 122 Atherton Road, Oakleigh	156.00	Cheque	04/05/01
Miss Mary Cameron, 49A Walpole Street, Kew	360.00	''	''
Mr Norio Goto, PSC 473, Box 96, FPO AP 96349-0005, USA	198.00	''	''
Ms Hilda M. Hall, Deceased, C/- Mr W. J. Hall, 6 Electra Street, Williamstown	223.68	''	''
Mr Glenister Douglas Liddell, 6 Guitau Street, Boroko, Papua New guinea	120.00	''	

03089

CONTACT: ELAINE HARE, PHONE: (03) 9611 5714.

Unclaimed Moneys Act 1962

Register of Unclaimed Moneys held by the —

<i>Name of Owner on Books and Last Known Address</i>	<i>Total Amount Due to Owner</i>	<i>Description Of Unclaimed Money</i>	<i>Date when Amount first became Payable</i>
GES INTERNATIONAL LIMITED (SINGAPORE)			
\$			
Yuan Zheng, Block 892B, #09-171 Woodlands Drive 50, Singapore 731892	210.00	Cheque	14/12/01
Yuan Zheng, Block 892B, #09-171 Woodlands Drive 50, Singapore 731892	150.00	”	23/04/01

03094

CONTACT: ELAINE HARE, PHONE: (03) 9611 5714.

Unclaimed Moneys Act 1962

Register of Unclaimed Moneys held by the —

<i>Name of Owner on Books and Last Known Address</i>	<i>Total Amount Due to Owner</i>	<i>Description Of Unclaimed Money</i>	<i>Date when Amount first became Payable</i>
GES INTERNATIONAL LIMITED			
\$			
Antonio R. Fresta Pty Limited, 76 James Street, Punchbowl, NSW	277.20	Cheque	14/12/01
Hawke Family Pty Ltd, “Hawke Family A/c”, 97 Kingston Street, Haberfield, NSW	285.00	”	23/04/01
Mr Russell Lindsay King & Mrs Terese Elizabeth King, “King Superannuation Fund A/c”, 14 Garratt Road, Bayswater, WA	147.00	”	14/12/01
Mr Russell Lindsay King & Mrs Terese Elizabeth King, “King Superannuation Fund A/c”, 14 Garratt Road, Bayswater, WA	114.00	”	23/04/01
Macwil Nominees Pty Ltd, C/- McKinley Wilson & Co, 459 Collins Street, Melbourne	183.75	”	14/12/01
Macwil Nominees Pty Ltd, C/- McKinley Wilson & Co, 459 Collins Street, Melbourne	142.50	”	23/04/01
Towerview Restaurant Pty Ltd, PO Box 86, New Gisborne	147.00	”	14/12/01
Towerview Restaurant Pty Ltd, PO Box 86, New Gisborne	114.00	”	23/04/01

03093

CONTACT: ELAINE HARE, PHONE: (03) 9611 5714.

Unclaimed Moneys Act 1962

Register of Unclaimed Moneys held by the —

<i>Name of Owner on Books and Last Known Address</i>	<i>Total Amount Due to Owner</i>	<i>Description Of Unclaimed Money</i>	<i>Date when Amount first became Payable</i>
CROWN LIMITED			
	\$		
Mr Philip Donald Hislop Lapinkaari, 20A 6 Fl - 33180 Tampere, New Zealand	150.71	Cheque	30/11/01
I. J. Ahrens & Assoc Pty Ltd, "The Ahrens Super Fund A/c", PO Box 1046, Palm Beach, Qld	236.85	"	31/05/01
I. J. Ahrens & Assoc Pty Ltd, "The Ahrens Super Fund A/c", PO Box 1046, Palm Beach, Qld	238.15	"	30/11/01
Ms Jean Agatha Schnelle & Ms Susan Jean Barber, PO Box 600, Wodonga	238.15	"	"
Woods Family Investments, C/- Tower Trust Ltd, GPO Box 546, Adelaide, SA	885.92	"	"

03086

CONTACT: ELAINE HARE, PHONE: (03) 9611 5714.

Unclaimed Moneys Act 1962

Register of Unclaimed Moneys held by the —

<i>Name of Owner on Books and Last Known Address</i>	<i>Total Amount Due to Owner</i>	<i>Description Of Unclaimed Money</i>	<i>Date when Amount first became Payable</i>
WYNDHAM CITY COUNCIL			
	\$		
Pluto Press Pty Ltd	124.75	Cheque	28/02/02
P. Atanasovski, 15 Barrington Terrace, Point Cook	168.95	"	19/06/01
Haleb Malalai, 13 Kramer Street, Werribee Borders, The Jam Factory,	200.00	"	01/02/02
Shop 1/500 Chapel Street, South Yarra	1,101.57	"	13/07/00
Helen O'Grady Children's Drama Academy, 14 Jacqueline Court, Point Cook	200.00	"	06/12/01

03184

CONTACT: LISA STEWART, PHONE: (03) 9742 0878.

**GOVERNMENT AND OUTER BUDGET SECTOR AGENCIES
NOTICES**



CITY OF
WODONGA

**ROAD CLOSURE –
ADJACENT TO FORMER ALIGNMENT OF
BEECHWORTH MAIN ROAD**

Pursuant to the provisions of Section 206 and Clause 3 of Schedule 10 of the **Local Government Act 1989**, Wodonga Rural City Council at its meeting of 14 April 2003 resolved to close 2 small sections of road approximately 0.04 ha and 0.27 ha in area respectively adjacent to the former alignment of the Beechworth Main Road as shown hatched on the accompanying plan.

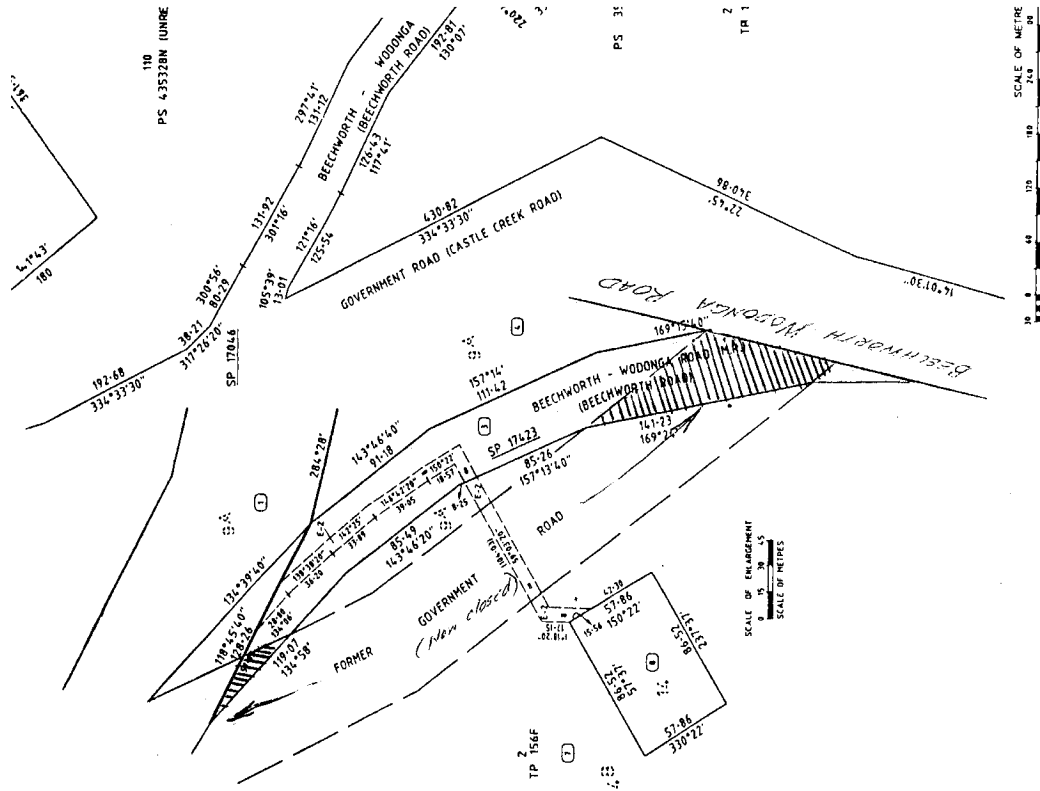

PETER MARSHALL
Chief Executive Officer

HUME CITY COUNCIL
Road Discontinuance

At its meeting on 14 April 2003 and acting under Clause 3 of Schedule 10 to the **Local Government Act 1989** Hume City Council resolved to discontinue the part of a road known as Mundy Road, Sunbury as shown hatched on the plan below.

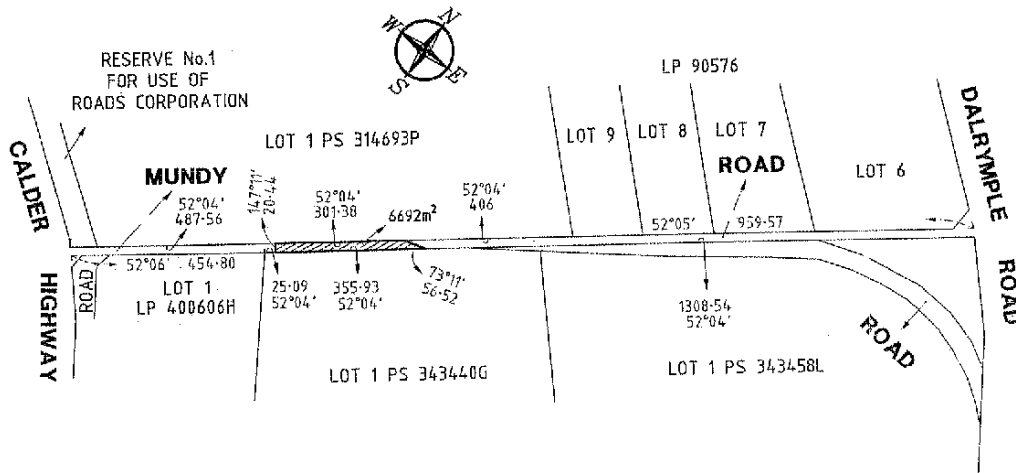

Mr DARRELL TRELOAR
Chief Executive Officer

NORTHERN GRAMPIANS
SHIRE COUNCIL
Public Holidays Act 1993

Notice is hereby given that the Northern Grampians Shire Council at its meeting held on 1 May 2003 declared Tuesday 4 November 2003 (Melbourne Cup Day) a Public Holiday in the township of St Arnaud.

PETER BROOKS
Chief Executive Officer

HOBSONS BAY CITY COUNCIL
Road Discontinuance

Pursuant to Section 206 and Schedule 10, Clause 3 of the **Local Government Act 1989**, the Hobsons Bay City Council has formed the opinion that the road at the rear of 206–222 Mason Street and adjacent to 1 Charlotte Street and 2 Hansen Street, Newport, and shown delineated on the plan below, is not reasonably required as a road for public use and resolved to discontinue the road and to sell the land from the road by private treaty to the abutting property owners.

The portion of road marked as E-1 is to be sold subject to the right, power or interest held by City West Water Limited in the road in connection with any sewers, drains or pipes under the control of that authority in or near the road.

The portion of road marked as E-2 is to be sold subject to the right, power or interest held by the Hobsons Bay City Council and City West Water in the road in connection with any sewers, drains or pipes under the control of those authorities in or near the road.

The portion of road marked as E-3 is to be sold subject to the right, power or interest held by the Hobsons Bay City Council in the road in connection with any drains or pipes under the control of that authority in or near the road.

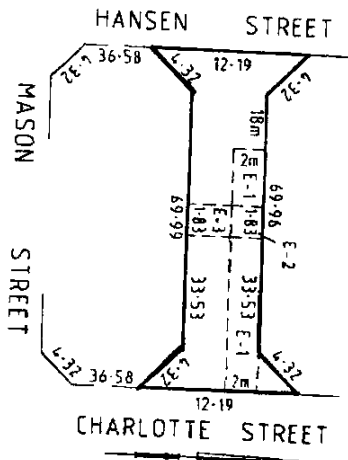

KENNETH McNAMARA
Chief Executive Officer

KINGSTON CITY COUNCIL

Road Discontinuance

Pursuant to Section 206 and Schedule 10, Clause 3 of the **Local Government Act 1989**, the Kingston City Council has formed the opinion that the road at the rear of 33 & 35 Patterson Street and adjacent to 1 Haldane Street, Bonbeach and shown by hatching and cross-hatching on the plan below, is not reasonably required as a road for public use and resolved to discontinue the road and to sell the land from the road by private treaty to the abutting property owners.

The section of road shown cross-hatched is to be sold subject to the right, power or interest held by South East Water Limited in the road in connection with any sewers, drains or pipes, under the control of that authority in or near the road.

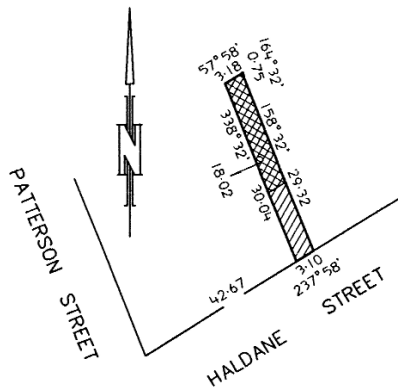

ROB SKINNER
Chief Executive Officer

SHIRE OF STRATHBOGIE

**Road Exchange
Berry's Lane, Longwood**

Pursuant to the provisions of Clause 2, Schedule 10 of the **Local Government Act 1989**, the Council having advertised its intentions in local papers and received no submissions pursuant to Section 223 of the **Local Government Act 1989**, resolved at its meeting of 26 April 2000, to authorise and approve the road exchange and closure set out on the plan below.

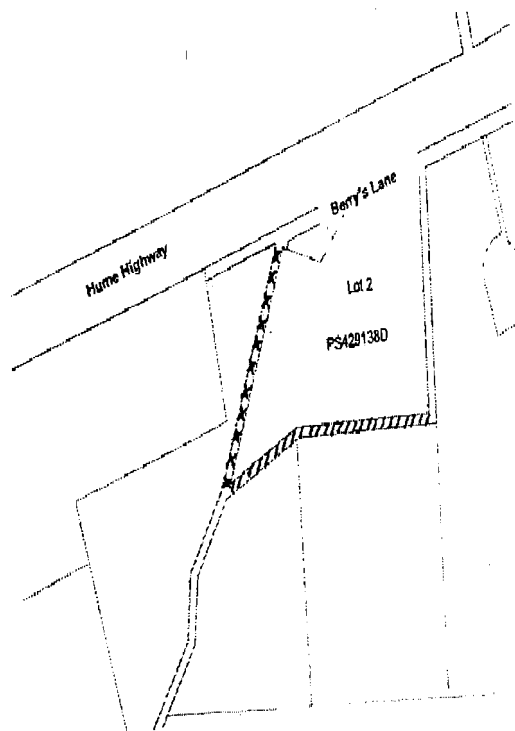

ROBYN ANTHONY
Executive Officer

**Planning and Environment Act 1987
GREATER BENDIGO PLANNING SCHEME
Notice of Preparation of an Amendment
Amendment C37**

The City of Greater Bendigo has prepared Amendment C37 to the Greater Bendigo Planning Scheme.

The Amendment applies to land bounded by Scott Street (on its southern boundary), Priest Street (eastern boundary), Powercor Depot

(northern boundary) and the Bendigo Creek (western boundary) in the Greater Bendigo municipality.

The land affected by the Amendment is CA's 1, 2, 3, 4, 5 and 6, Section 15, Parish of Sandhurst at White Hills; and CA's 4, 5, and 5A, Section 17, Parish of Sandhurst at White Hills.

The Amendment proposes to rezone the land from Business 3 Zone (B3Z) to Residential 1 Zone (R1Z) and removes a Land Subject to Inundation Overlay (LSIO) from the land.

You may inspect the Amendment, any documents that support the Amendment and the explanatory report about the Amendment at the following locations: at the office of the planning authority, City of Greater Bendigo, Planning and Building Business Unit, "The Mill", 15 Hopetoun Street, Bendigo; at the Department of Sustainability and Environment, (VicRoads Office), 57 Lansell Street, Bendigo and at the Department of Sustainability and Environment, Planning Information Centre, Upper Plaza, Nauru House, 80 Collins Street, Melbourne.

This can be done during office hours and is free of charge.

Any person who may be affected by the Amendment may make a submission to the planning authority.

The closing date for submissions is 23 June 2003. Submissions must be sent to:— Mr Andrew Paul, the Chief Executive Officer, City of Greater Bendigo, PO Box 733, Bendigo, Vic. 3552.

Creditors, next-of-kin and others having claims against the estate of any of the undermentioned deceased persons are required to send particulars of their claims to State Trustees Limited, ABN 68 064 593 148, 168 Exhibition Street, Melbourne, Victoria 3000, the personal representative, on or before 24 July 2003 after which date State Trustees Limited may convey or distribute the assets having regard only to the claims of which State Trustees Limited then has notice.

BAYARD, Moretta Evelyn, late of Reg Geary House, 54 Pinnacle Close, Melton South, pensioner, and who died on 5 March 2003.

BULL, Dorothy, late of 50 Gerton Avenue, Boronia, retired hairdresser, and who died on 11 March 2003.

CLARKE, William Arthur, late of Unit 4, 11 Early Street, Mansfield, pensioner, and who died on 31 December 2002.

CROSS, Eunice Joy, late of Parkland Close, 283 Cotham Road, Kew East, retired public servant, and who died on 31 March 2003.

DUVAL, Joyce Constance, late of Unit 1, 29 Howard Street, Box Hill, and who died on 21 February 2003.

FIELD, Desmond James, late of 15 Hinkler Street, Mount Martha, Victoria 3934, retired, and who died on 21 March 2003.

MANICOLO, Charles Ignatius, late of 41 Lambeth Street, Kensington, postman, and who died on 21 January 2003.

WEBSTER, Vera Mary, late of Unit 24, 16 Seddon Street, Ivanhoe, home duties, and who died on 10 March 2003.

Dated at Melbourne, 15 May 2003

LAURIE TAYLOR,
Estate Manager
State Trustees Limited

STATE TRUSTEES LIMITED

ACN 064 593 148

Section 79

Notice is hereby given that State Trustees Limited, ACN 064 593 148 intends administering the estates of:—

RACHEL ATTARD, late of Munro Manor, 45–47 Munro Street, Coburg, Victoria, retired, deceased, who died on 6 April 2003 leaving a Will dated 21 February 1997.

MARGARET ROSE BOND, late of Burnside Nursing Home, 55 Burnside Street, Deer Park, Victoria, pensioner, deceased, who died on 1 March 2003 leaving a Will dated 6 September 2000.

VINCENT BUDRIUS, late of 32 Thorndon Drive, St Albans, Victoria, pensioner, deceased, who died on 29 March 2003 leaving a Will dated 19 April 1997.

FLORENCE MAY DONALDSON, late of St Winifred Private Nursing Home, 14 Caloola Avenue, Oakleigh, Victoria, retired, deceased intestate, who died on 20 March 2003.

MARGARET PATRICIA DOWLING, late of Hillvale, 35 Yeovil Road, Burwood, Victoria, pensioner, deceased intestate, who died on 4 April 2003.

MARGARET JEAN HUGHES, late of Ardeer Nursing Home, 30 North Street, Ardeer, Victoria, retired, deceased intestate, who died on 6 April 2003.

RONALD PERKINS, late of 6 Warner Street, Malvern, Victoria, retired, deceased intestate, who died on 4 February 2003.

Creditors, next-of-kin and others having claims against the abovementioned estates are required pursuant to Section 33 of the **Trustee Act 1958** to send particulars of their claims against the abovementioned estates to State Trustees Limited, 168 Exhibition Street, Melbourne, Victoria, on or before 28 July 2003 after which date State Trustees Limited, ACN 064 593 148, may convey or distribute the assets of the abovementioned estates having regard only to the claims of which it then has notice.

EXEMPTION

Application No. A22/2003

The Victorian Civil and Administrative Tribunal has considered an application pursuant to Section 83 of the **Equal Opportunity Act 1995** by YMCA of Moreland – Brunswick City Baths for exemption from Sections 13, 14, 42, 100 and 195 of that Act. The application for exemption is to enable the applicant to engage in the specified conduct.

In this exemption the specified conduct means — to operate the Brunswick Baths complex on any Sunday evening, from 8.30 p.m. to 10.30 p.m., for women only, to advertise that service, and to advertise and employ in relation to that service women only. This term does not authorise the exclusion of women from the service on grounds such as ethnicity or religious belief. It does not authorise the charging to women for use of that service, of fees lower than those charged to users of the service during ordinary operating hours.

Upon reading the material submitted in support of the application and upon hearing submissions from Ms J. Hanson, Ms M. Simmons and Ms K. Keuneman and for the Reasons for Decision given by the Tribunal on 16 May 2003, the Tribunal is satisfied that it is

appropriate to grant an exemption from Sections 13, 14, 42, 100 and 195 of the Act to engage in the specified conduct.

The Tribunal hereby grants an exemption to the applicant from the operation of Sections 13, 14, 42, 100 and 195 of the **Equal Opportunity Act 1995** to enable the applicant to engage in the specified conduct.

This exemption is to remain in force from the day on which notice of the exemption is published in the Government Gazette until 21 May 2006.

Dated 16 May 2003

C. MCKENZIE
Deputy President

Department of Treasury and Finance
SALE OF CROWN LAND
BY PUBLIC AUCTION

Date of Auction: Saturday 21 June 2003 at 12 noon.

Reference: 2003/00588.

Address of Property: 3 Fletcher Road, Beechworth.

Crown Description: Crown Allotment 2007, Township of Beechworth, Parish of Beechworth.

Terms of Sale: Deposit 10%, Balance 60 days.

Area: 8590 square metres.

Officers Co-ordinating Sale: Peter Jackel/Wayne Swingler, Victorian Government Property Group, Department of Treasury and Finance, 5/1 Treasury Place, Melbourne, Vic. 3002.

Selling Agent: Beechworth First National, 75 Ford Street, Beechworth, Vic. 3747.

JOHN LENDERS MLC
Minister for Finance

Department of Treasury and Finance
SALE OF CROWN LAND
BY PUBLIC AUCTION

Date of Auction: Saturday 21 June 2003 at 12.30 p.m.

Reference: 2002/00535.

Address of Property: Warner Road, Beechworth.

Crown Description: Crown Allotment 2008, Township of Beechworth, Parish of Beechworth.

Terms of Sale: Deposit 10%, Balance 60 days.

Area: 3.667 hectares.

Officers Co-ordinating Sale: Peter Jackel/
Wayne Swingler, Victorian Government
Property Group, Department of Treasury and
Finance, 5/1 Treasury Place, Melbourne, Vic.
3002.

Selling Agent: Beechworth First National,
75 Ford Street, Beechworth, Vic. 3747.

JOHN LENDERS MLC
Minister for Finance

Department of Treasury and Finance

SALE OF CROWN LAND
BY PUBLIC AUCTION

Date of Auction: Friday 27 June 2003 at 1.00
p.m.

Reference: 2003/00056.

Address of Property: 383–385 Canterbury
Road, Chatham.

Crown Description: Crown Allotment 158,
Parish of Boroondara.

Terms of Sale: Deposit 10%, Balance 60 days.

Area: 1,024 square metres.

Officer Co-ordinating Sale: Wayne Swingler,
Victorian Government Property Group,
Department of Treasury and Finance, 5/1
Treasury Place, Melbourne, Vic. 3002.

Selling Agent: Jellis Craig, 244 Whitehorse
Road, Balwyn, Vic. 3103.

JOHN LENDERS MLC
Minister for Finance

Department of Treasury and Finance

SALE OF CROWN LAND
BY PUBLIC AUCTION

Date of Auction: Saturday 28 June 2003 at
11.00 a.m.

Reference: 2003/00057.

Address of Property: 104 Balwyn Road,
Balwyn.

Crown Description: Crown Allotment 157,
Parish of Boroondara.

Terms of Sale: Deposit 10%, Balance 60/90
days.

Area: 1,012 square metres.

Officer Co-ordinating Sale: Wayne Swingler,
Victorian Government Property Group,
Department of Treasury and Finance, 5/1
Treasury Place, Melbourne, Vic. 3002.

Selling Agent: Di Baker Real Estate,
150 Cotham Road, Kew, Vic. 3101.

JOHN LENDERS MLC
Minister for Finance

Associations Incorporation Act 1981

SUB-SECTION 36E(5)

Notice is hereby given that the incorporation
of the associations mentioned below are
cancelled in accordance with Section 36E(5) of
the **Associations Incorporation Act 1981**.

A.F.L. Foundation Inc., Fish Creek Social
Club, Golden Phoenix Marching Club Inc.,
Goorambat Tennis Club Inc., Goornong Golf
Club Inc., Goulburn Murray Rugby League Inc.,
Goulburn Valley Community Care Centre Inc.,
Greater Shepparton Community Playground
Inc., Greensborough Cricket Club Inc.,
Greensborough Districts Rangers Cricket Club
Inc., Hadfield Tennis Club Inc., Hamilton
Smallbore and Air rifle Club Inc., Hampton Park
Hornets Basketball Club (H.P.H.B.C.)
Inc., Hampton Park United Soccer Club Inc.,
Hanson Road IWC Playgroup Inc., Hastings
Calisthenics College Inc., Hawthorn Amateur
Football Club Inc., Healesville Football Club
Inc., Healesville Municipal Band Inc.,
Heathdale Community Centre Inc., Heights
Netball Club (Royal Park) Inc., Hellenic Studies
Forum Inc., High Country Wedding Association
Inc., Historic Maldon Kennel Club Inc., Historic
Touring Car Association of Victoria Inc.,
Hobsons Bay Tourism Industry Association Inc.,
Hoechst Social Club Inc., Holden Sporting Car
Club of Victoria Inc., Homewood/North
Yea/Molesworth Neighbourhood Watch Inc.,
Hopetoun Cricket Club Inc., Hopkins River
Sports Club Inc., Horsham City Soccer and
Sporting Club Inc., Horsham Community Youth
Centre Inc., Horsham Cricket Club Inc.,
Horsham District Football League Inc.,
Horsham Super League Darts Association Inc.,
Horsham Yacht Club Inc., Independent Nursing
Homes & Extended Care Association (Vic.)
Inc., Inter Company Network Inc., International
Teams Ministries Australia Inc., International
Training in Communication Camberwell
Communicators Inc., Inverleigh Junior Football

Club Inc., Inverloch Tourism & Business Association Inc., Jacana Football Club Inc., Jancourt & District Herd Test Association Inc., Job Network Members Association (South Western Victoria) Inc., Jordanville Senior Citizens Inc., Jung Cricket Club Inc., Junior Soccer Association of Red Cliffs Inc., K.P.R. Basketball Club Inc., Kangaroo Flat Pre-School Centre Inc., Kaniva District Football Club Inc., Karingal Playgroup Association Inc., Karnavals Club The Westernport Koalas Inc., Kealba Green Gully Sports Association Inc., Keilor Pony Club Inc., Keilor Softball Club Inc., Kennett River Surf Lifesaving Club Inc., Kensington Retail Traders Association Inc., Keysborough Christian Fellowship Inc., Keysborough Netball Club Inc., Keysborough Sporting Club Inc., Kialla Promotions Inc., Kialla Youth Group Inc., Kinglake Cricket Club Inc., Kiss FM Inc., Kiwanis Club of Cobram-Barooga Inc., Knox-Sherbrooke Swimming Centre Inc., Knoxfield Tennis Club Inc., Koo Wee Rup-Lang Lang Rotaract Club Inc., Koroit & District Development Association Inc., Koroit Jigsaw Playgroup Inc., Korumburra Volleyball Inc., Laharum Tennis Club Inc., Lake Bolac Ball Association Inc., Lakes Entrance Endurance Riders Club Inc., Latrobe Cricket Club Inc., Latrobe Valley Married Womens Amateur Basketball Association Inc., Launching Place Community Group Inc., Laverton Garden Club Inc., Leghorn Club of Victoria Inc., Leisure Link (Association For * Leisure Experience) Inc., Leongatha Town Netball Club Inc., Lethbridge Tennis Club Inc., Life Education Centre Gippsland Inc., Life Education Cranbourne/Pakenham and District Inc., Light Workers United-Geelong Region Inc., Lillydale Pre-School Association Inc., Lilydale Football Club (Juniors) Inc., Lilydale Golf Club Inc., Lions Club of Clifton Hill Inc., Lions Club of Strathmore-Gladstone Park Inc., Little Desert Square Dance Club Inc., Local Government Planners' Association of Victoria Inc., Locksley Tennis Club Inc., Loddon Mallee Disability Council Inc., Longerenong Student Association Inc., Lower Cape Bridgewater Hall and Recreation Reserve Inc., Loyola Musical Society Inc., Lubeck Tennis Club Inc., M.G. Owners Club Inc., Macedonian Community Council of Melbourne And Victoria Inc., Maldon Amateur Swimming and Life-Saving Club Inc., Mallacoota Inlet Business & Tourism Association Inc., Mallee Leisure Access Inc., Malvern And Caulfield Youth Accommodation Service Inc., Mansfield District L.E.T.S. Inc., Marlo Ratepayers and Residents Association Inc., Maroona Tennis Club Inc., Maroondah Pre-School Parents Club Inc., Maroondah Social Club Inc., Maroondah Social Health Centre Staff Association Inc., Maryborough Golden Wattle Festival Association Inc., Maryborough Rovers Football Club Inc., McDonald House Hostel Inc., Meeniyan Apex Club Inc., Melbourne Atari Computer Enthusiasts (Mace) Inc., Melbourne Fashion And Design Incubator Inc., Melbourne International Choral Festival Inc., Melbourne International Festival Of Choirs Inc., Melbourne Leather Pride Association Inc., Melbourne School of Rhythmic Gymnastics Inc., Melbourne University Netball Club Inc., Melbourne University Water Ski Club Inc., Melbourne Wolves Inline Hockey Club Inc., Melton Sportfishing Club Inc., Melton Tennis Club Inc., Mentone Chamber of Commerce Inc., Metu Alumni Club of Australia Inc., Mid Week Cricket Association Inc., Miepoll Cricket Club Inc., Milawa Cricket Club Inc., Mildura B.M.X. Club Inc., Mildura Equestrian Club Inc., Miners Rest Progress Association Inc., Minyip Community Recreation Facility Inc., Moe Angling Field & Game Club Inc., Monash University Hang Gliding and Paragliding Club Inc., Monash University Sailing Club Inc., Monash University Soccer Club Inc., Monbulk And District Basketball Club Inc., Monbulk Aquatic Club Inc., Monbulk Clematis Adult Riding Club Inc., Monterey Calisthenic Club Inc., Montmorency Cricket Club Inc., Moodemere Corowa Water Ski Club Inc., Moonambel-Frenchmans Landcare Project Inc., Moorabool Care Inc., Moorabool Soccer Club Inc., Moorooduc Aero Club Inc., Mooroolbark East Ladies Netball Club Inc., Mortgage Review Task Force Inc., Motorsport Promoters of Australia Inc., Mount Eliza Village Cup Day Fair Inc., Mounties Junior Football Club Inc., Mountview Corner House Inc., Mt Ida College Inc., Mt Moriac Tennis Club Inc., Muckatah Adult Riding Club Inc., Mullum Little Athletics Club Inc., Myrtleford Table Tennis Association Inc., Narre Hallam Motor Cycle Club Inc., Nathalia District Rifle Club Inc., Neerim South Pony Club Inc., Newry Tennis Club Inc., Nhill Angling Club Inc., Niddrie Traders Association Inc., Nillahcootie Sailing Club Inc., Nilma Darnum Football & Netball Club Inc., Nissan

Car Club Australia Inc., Noble Park Amateur Swimming & Life Saving Club Inc., Noble Park Bears Football Club Inc., Noble Park Roller Skating Club Inc., Noble Park United Soccer Club Inc., North East Mobile Pre-School Inc., North Gippsland Football League Trainers Association Inc., North Hamilton Cricket Club Inc., North Old Boys Amateur Football Club Inc., North West Metropolitan Softball Region Inc., North Western Regional Housing Council Inc., Northern District Football Board Vic., Northern Marching Zone Inc., Northern Socials Cricket Club Inc., Northern Suburbs All Breeds Kennel Club Inc., Northern Suburbs Arab Senior Citizens Club Inc., Nunawading Primary Netball Club Inc., Oak Park Tennis Club Inc., Ocean Grove Rate Payers Association Inc., OGG Ski Club Inc., Old Brighton Grammarians Water Polo Club Inc., Old Mother Hubbards Toy Library Inc., Old Paradians' Association Amateur Football Club Inc., Ormond Cricket Club Inc., Osbornes Flat Tennis Club Inc., Otway Tennis Association Inc., Outer East Regional Housing Council Inc., Outer North West Youth Housing Inc., Pacific Asia Travel Association—Southern Australia Chapter Inc., Pdraig Pearse Gaelic Athletic Club Inc., Pakenham Chamber of Commerce Inc., Pakenham Pigeon Racing Club Inc., Parents For Music – A Family Music Association Inc., Pascoe Vale Gymnastics Association Inc., Paynesville Cricket Club Inc., Pearcedale Sports Club Inc., Peninsula Rural Landholders Inc., Peninsula Young Mens Christian Association Inc., Pentland Hills Landcare Group Inc., Personnel Development Project Inc., Philippine—Australian Foundation (Victoria) Inc., Phillip Island Basketball Association Inc., Phosphate Employees Social Club Inc., Pier Hotel Anglers Club Inc., Pines Football Club Inc., Pines Infant Welfare & Pre-School Centre Inc., Pinoy—Aussie Family Social Club of Victoria Inc., Pomborneit Cricket Club Inc., Poppets Playgroup Inc., Port Fairy Professional Fisherman's Association Inc., Port Fairy Unsubsidised 3 Year Old Kindergarten Group Inc., Port Phillip Arts Liaison and Management Inc., Port Phillip Netball Association Inc., Portarlinton Sports Club Inc., Portland & District Thoroughbred Owners & Trainersclub Inc., Portland Polo Cross Club Inc., Portland/Flinders Cricket Club Inc., Powerlifting Australia Inc., Preston/Reservoir Skills Training Centre Inc., Preston Cycling Club Inc., Preston

Falcons Volleyball Club Inc., Principals Association of Specialist Schools Victoria Inc.

Dated this 20 May 2003

ANN HAMMANN

Deputy Registrar of Incorporated Associations

Co-operatives Act 1996

ASGAARD ALPINE CLUB
CO-OPERATIVE LIMITED

“DE ‘REEL THING” CO-OPERATIVE LTD
GREY MATTERS CO-OPERATIVE LIMITED
MOUNTAIN GATE PRIMARY SCHOOL
CO-OPERATIVE LTD

Notice is hereby given in pursuance of Section 316(1) of the **Co-operatives Act 1996** and Section 601AB(3)(e) of the **Corporations Act 2001** that, at the expiration of two months from the date hereof, the names of the aforementioned co-operatives will, unless cause is shown to the contrary, be struck off the register and the co-operatives will be dissolved.

Dated at Melbourne 19 May 2003

ANDREW LEVENS

Deputy Registrar of Co-operatives

Health Services Act 1988

DECLARATION OF APPROVED
QUALITY ASSURANCE BODY

I declare the Clinical Risk Management — Reference Panel, established by West Vic Division of General Practice, is an approved quality assurance body under Section 139 for the purposes of part 7 of the **Health Services Act 1988**.

Dated 19 May 2003

BRONWYN PIKE

Minister for Health

Health Services Act 1988

DECLARATION OF APPROVED
QUALITY ASSURANCE BODY

I declare the Barwon Health Clinical Risk Management Committee, Suicide Audit Committee, The Mortality Review Committee, Anaesthetics Morbidity/Mortality Committee and Women's and Children's Clinical Events Committee established by Barwon Health, is an

approved quality assurance body under Section 139 for the purposes of part 7 of the **Health Services Act 1988**.

Dated 19 May 2003

BRONWYN PIKE
Minister for Health

Local Government Act 1989

APPROVAL OF AGREEMENT BETWEEN
THE COLAC–OTWAY SHIRE COUNCIL,
THE CORANGAMITE SHIRE COUNCIL,
THE MOYNE SHIRE COUNCIL AND
THE WARRNAMBOOL CITY COUNCIL
TO OPERATE A REGIONAL LIBRARY
CORPORATION

I, Candy Broad, MLC, Minister for Local Government, acting pursuant to Section 196 (2) of the **Local Government Act 1989** hereby approve of the Agreement executed by the Colac–Otway Shire Council, the Corangamite Shire Council, the Moyne Shire Council and the Warrnambool City Council for the operation of a Regional Library Corporation under Section 196 of the **Local Government Act 1989**.

CANDY BROAD MLC
Minister for Local Government

Land Acquisition and Compensation Act 1986

FORM 7 S.21
Reg. 16

Notice of Acquisition

Compulsory Acquisition of Interest in Land

The Secretary to the Department of Infrastructure, declares that by this notice it acquires the following interest in the land described as part of Parish of Ringwood comprising 2.031 hectares and being land described in Certificate of Title Volume 10070, Folio 474, shown as Parcels 179, 180 and 181 on Survey Plan 20410B.

Interest Acquired: That of Macrobertson Pty Ltd and all other interests.

Published with the authority of the Secretary to the Department of Infrastructure.

Dated 22 May 2003

For and on behalf of the Secretary
to the Department of Infrastructure:
GERRY TURNER,
Manager Property Services Department,
Roads Corporation

Land Acquisition and Compensation Act 1986

FORM 7 S.21
Reg. 16

Notice of Acquisition

Compulsory Acquisition of Interest in Land

The Secretary to the Department of Infrastructure declares that by this notice it acquires the following interest in the land described as part of Lot 1 on Plan of Subdivision 023181 and part of Lot 1 on Title Plan 116173J, (formerly known as Lot 2 on Plan of Subdivision 23181, Parish of Ringwood comprising 634.0 square metres and being land described in Certificate of Title Volume 7706, Folio 037 and Certificate of Title Volume 9659, Folio 156, shown as Parcels 56, 57, 63 and 64 on Survey Plan 20388A.

Interest Acquired: That of Zagame Supergym Pty Ltd and all other interests.

Published with the authority of the Secretary to the Department of Infrastructure.

Dated 22 May 2003

For and on behalf of the Secretary
to the Department of Infrastructure:
GERRY TURNER,
Manager Property Services Department,
Roads Corporation

Land Acquisition and Compensation Act 1986

FORM 7 S.21
Reg. 16

Notice of Acquisition

Compulsory Acquisition of Interest in Land

The Secretary to the Department of Infrastructure, declares that by this notice it acquires the following interest in the land described as part of Common Property on Plan of Strata Subdivision 020243, Parish of Ringwood comprising 109.0 square metres and shown as Parcel 65 on Survey Plan 20388A.

Interest Acquired: That of Bayswater Exhaust Centre Pty Ltd and all other interests.

Published with the authority of the Secretary to the Department of Infrastructure.

Dated 22 May 2003

For and on behalf of the Secretary
to the Department of Infrastructure:
GERRY TURNER,
Manager Property Services Department,
Roads Corporation

Land Acquisition and Compensation Act 1986

FORM 7 S.21
Reg. 16

Notice of Acquisition

Compulsory Acquisition of Interest in Land

The Secretary to the Department of Infrastructure, declares that by this notice it acquires the following interest in the land described as part of Lot Unit 2 on Plan of Strata Subdivision 020243, Parish of Ringwood comprising 115.0 square metres and being land described in Certificate of Title Volume 9551, Folio 703, shown as Parcel 66 on Survey Plan 20388A.

Interest Acquired: That of Bayswater Exhaust Centre Pty Ltd and all other interests.

Published with the authority of the Secretary to the Department of Infrastructure.

Dated 22 May 2003

For and on behalf of the Secretary
to the Department of Infrastructure:
GERRY TURNER,
Manager Property Services Department,
Roads Corporation

Land Acquisition and Compensation Act 1986

FORM 7 S.21
Reg. 16

Notice of Acquisition

Compulsory Acquisition of Interest in Land

The Secretary to the Department of Infrastructure, declares that by this notice it acquires the following interest in the land described as part of Unit 2 on Strata Plan 020243, Parish of Ringwood comprising 115.0 square metres and being land described in Certificate of Title Volume 9551, Folio 703, shown as Parcels 66 on Survey Plan 20388A.

Interest Acquired: That of Fatuor Dion Nominees Pty Ltd and all other interests.

Published with the authority of the Secretary to the Department of Infrastructure.

Dated 22 May 2003

For and on behalf of the Secretary
to the Department of Infrastructure:
GERRY TURNER,
Manager Property Services Department,
Roads Corporation

Land Acquisition and Compensation Act 1986

FORM 7 S.21
Reg. 16

Notice of Acquisition

Compulsory Acquisition of Interest in Land

The Secretary to the Department of Infrastructure, declares that by this notice it acquires the following interest in the land described as part of Common Property on Strata Plan 020243, Parish of Ringwood comprising 109.0 square metres, shown as Parcels 65 on Survey Plan 20388A.

Interest Acquired: That of Fatuor Dion Nominees Pty Ltd and all other interests.

Published with the authority of the Secretary to the Department of Infrastructure.

Dated 22 May 2003

For and on behalf of the Secretary
to the Department of Infrastructure:
GERRY TURNER,
Manager Property Services Department,
Roads Corporation

Land Acquisition and Compensation Act 1986

FORM 7 S.21
Reg. 16

Notice of Acquisition

Compulsory Acquisition of Interest in Land

The Secretary to the Department of Infrastructure, declares that by this notice it acquires the following interest in the land described as part of Common Property on Plan of Strata Subdivision 020243, Parish of Ringwood comprising 109.0 square metres and shown as Parcel 65 on Survey Plan 20388A.

Interest Acquired: That of Midas Australia Pty Ltd and all other interests.

Published with the authority of the Secretary to the Department of Infrastructure.

Dated 22 May 2003

For and on behalf of the Secretary
to the Department of Infrastructure:
GERRY TURNER,
Manager Property Services Department,
Roads Corporation

Land Acquisition and Compensation Act 1986

FORM 7 S.21

Reg. 16

Notice of Acquisition

Compulsory Acquisition of Interest in Land

The Secretary to the Department of Infrastructure, declares that by this notice it acquires the following interest in the land described as part of Unit 2 on Plan of Strata Subdivision 020243, Parish of Ringwood comprising 115.0 square metres and being land described in Certificate of Title Volume 9551, Folio 703, shown as Parcel 66 on Survey Plan 20388A.

Interest Acquired: That of Midas Australia Pty Ltd and all other interests.

Published with the authority of the Secretary to the Department of Infrastructure.

Dated 22 May 2003

For and on behalf of the Secretary to the Department of Infrastructure:
GERRY TURNER,
Manager Property Services Department,
Roads Corporation

Land Acquisition and Compensation Act 1986

FORM 7 S.21

Reg. 16

Notice of Acquisition

Compulsory Acquisition of Interest in Land

The Secretary to the Department of Infrastructure, declares that by this notice it acquires the following interest in the land described as part of Crown Portion 3 and part of former Government Road, Parish of Ringwood comprising 317.0 square metres and being land described in Certificate of Title Volume 9176, Folio 312, shown as Parcel 68 on Survey Plan 20388A.

Interest Acquired: That of Tajis Holdings Pty Ld and all other interests.

Published with the authority of the Secretary to the Department of Infrastructure.

Dated 22 May 2003

For and on behalf of the Secretary to the Department of Infrastructure:
GERRY TURNER,
Manager Property Services Department,
Roads Corporation

Land Acquisition and Compensation Act 1986

FORM 7 S.21

Reg. 16

Notice of Acquisition

Compulsory Acquisition of Interest in Land

The Secretary to the Department of Infrastructure, declares that by this notice it acquires the following interest in the land described as part of Crown Portion 3 and part of a former Government Road, Parish of Ringwood comprising 317.0 square metres and being land described in Certificate of Title Volume 9176, Folio 312, shown as Parcel 68 on Survey Plan 20388A.

Interest Acquired: That of Worldwide Factoring Pty Ltd and all other interests.

Published with the authority of the Secretary to the Department of Infrastructure.

Dated 22 May 2003

For and on behalf of the Secretary to the Department of Infrastructure:
GERRY TURNER,
Manager Property Services Department,
Roads Corporation

Land Acquisition and Compensation Act 1986

FORM 7 S.21

Reg. 16

Notice of Acquisition

Compulsory Acquisition of Interest in Land

The Secretary to the Department of Infrastructure, declares that by this notice it acquires the following interest in the land described as part of Common Property on Plan of Strata Subdivision 020243, Parish of Ringwood comprising 109.0 square metres and shown as Parcels 65 on Survey Plan 20388A.

Interest Acquired: That of O'Brien Glass Industries Limited and all other interests.

Published with the authority of the Secretary to the Department of Infrastructure.

Dated 22 May 2003

For and on behalf of the Secretary to the Department of Infrastructure:
GERRY TURNER,
Manager Property Services Department,
Roads Corporation

Land Acquisition and Compensation Act 1986

FORM 7 S.21
Reg. 16

Notice of Acquisition

Compulsory Acquisition of Interest in Land

The Secretary to the Department of Infrastructure, declares that by this notice it acquires the following interest in the land described as part of Unit 1 on Plan of Strata Subdivision 020243, Parish of Ringwood comprising 122.0 square metres and being land described in Certificate of Title Volume 9551, Folio 702, shown as Parcels 67 on Survey Plan 20388A.

Interest Acquired: That of O'Brien Glass Industries Limited and all other interests.

Published with the authority of the Secretary to the Department of Infrastructure.

Dated 22 May 2003

For and on behalf of the Secretary to the Department of Infrastructure:
GERRY TURNER,
Manager Property Services Department,
Roads Corporation

Land Acquisition and Compensation Act 1986

FORM 7 S.21
Reg. 16

Notice of Acquisition

Compulsory Acquisition of Interest in Land

The Secretary to the Department of Infrastructure, declares that by this notice it acquires the following interest in the land described as part of Common Property on Strata Plan 020243, Parish of Ringwood comprising 109.00 square metres and shown as Parcels 65 on Survey Plan 20388A.

Interest Acquired: That of Reims Pty Ltd and all other interests.

Published with the authority of the Secretary to the Department of Infrastructure.

Dated 22 May 2003

For and on behalf of the Secretary to the Department of Infrastructure:
GERRY TURNER,
Manager Property Services Department,
Roads Corporation

Land Acquisition and Compensation Act 1986

FORM 7 S.21
Reg. 16

Notice of Acquisition

Compulsory Acquisition of Interest in Land

The Secretary to the Department of Infrastructure, declares that by this notice it acquires the following interest in the land described as part of Unit 1 on Strata Plan 020243, Parish of Ringwood comprising 122.0 square metres and being land described in Certificate of Title Volume 9551, Folio 702, shown as Parcels 67 on Survey Plan 20388A.

Interest Acquired: That of Reims Pty Ltd and all other interests.

Published with the authority of the Secretary to the Department of Infrastructure.

Dated 22 May 2003

For and on behalf of the Secretary to the Department of Infrastructure:
GERRY TURNER,
Manager Property Services Department,
Roads Corporation

Land Acquisition and Compensation Act 1986

FORM 7 S.21
Reg. 16

Notice of Acquisition

Compulsory Acquisition of Interest in Land

The Secretary to the Department of Infrastructure, declares that by this notice it acquires the following interest in the land described as part of Lot 1 & 2 on Title Plan 341912N (formerly known as part of Portion 3 and part of former Government Road) Parish of Ringwood comprising 83.0 square metres and being land described in Certificate of Title Volume 4312, Folio 266, shown as Parcel 69 on Survey Plan 20388.

Interest Acquired: That of Keith Norman Byers & Beverly Ruby Cooper and all other interests.

Published with the authority of the Secretary to the Department of Infrastructure.

Dated 22 May 2003

For and on behalf of the Secretary to the Department of Infrastructure:
GERRY TURNER,
Manager Property Services Department,
Roads Corporation

Land Acquisition and Compensation Act 1986

FORM 7

S.21

Reg. 16

Notice of Acquisition

Compulsory Acquisition of Interest in Land

The Secretary to the Department of Infrastructure, declares that by this notice it acquires the following interest in the land described as part of Lot 1 & 2 on Plan of Subdivision 341912N, (formerly known as part of Portion 3 and part of former Government Road) Parish of Ringwood comprising 83.0 square metres and being land described in Certificate of Title Volume 4312, Folio 266, shown as Parcel 69 on Survey Plan 20388A.

Interest Acquired: That of Maroondah Pty Ltd (formerly Adzam Pty Ltd) and all other interests.

Published with the authority of the Secretary to the Department of Infrastructure.

Dated 22 May 2003

For and on behalf of the Secretary to the Department of Infrastructure:
GERRY TURNER,
Manager Property Services Department,
Roads Corporation

Land Acquisition and Compensation Act 1986

FORM 7

S.21

Reg. 16

Notice of Acquisition

Compulsory Acquisition of Interest in Land

The Secretary to the Department of Infrastructure, declares that by this notice it acquires the following interest in the land described as part of Lot 2 on Title Plan 332240P and parts of Lots 1 and 2, on Plan of Subdivision No. 25743, Parish of Ringwood comprising 103.0 square metres and being land described in Certificate of Title Volume 8164, Folio 195; Certificate of Title Volume 8238, Folio 959; Certificate of Title Volume 7885, Folio 103, shown as Parcels 70, 71, 72 and 73 on Survey Plan 20388A.

Interest Acquired: That of Barro Group Pty Ltd and all other interests.

Published with the authority of the Secretary to the Department of Infrastructure.

Dated 22 May 2003

For and on behalf of the Secretary to the Department of Infrastructure:
GERRY TURNER,
Manager Property Services Department,
Roads Corporation

Land Acquisition and Compensation Act 1986

FORM 7

S.21

Reg. 16

Notice of Acquisition

Compulsory Acquisition of Interest in Land

The Secretary to the Department of Infrastructure, declares that by this notice it acquires the following interest in the land described as part of Lot 2, Title Plan 332240P and part of Lots 1 and 2 on Plan of Subdivision 25743, Parish of Ringwood comprising 103.0 square metres and being land described in Certificate of Title Volume 8164, Folio 195; Certificate of Title Volume 8238, Folio 959; Certificate of Title Volume 7885, Folio 103, shown as Parcels 70, 71, 72 and 73 on Survey Plan 20388A.

Interest Acquired: That of Maroondah Pty Ltd (formerly Adzam Pty Ltd) and all other interests.

Published with the authority of the Secretary to the Department of Infrastructure.

Dated 22 May 2003

For and on behalf of the Secretary to the Department of Infrastructure:
GERRY TURNER,
Manager Property Services Department,
Roads Corporation

Medical Practice Act 1994

NOTICE

Re: Dr Marek Sawczuk

A Panel of the Medical Practitioners Board of Victoria determined as a result of the formal hearing concluded on 24 February 2003 into Dr Sawczuk's professional conduct that Dr Sawczuk has engaged in unprofessional conduct

of a serious nature under s. 3(1)(a), (b), (h)(i) and (iv) of the **Medical Practice Act 1994** ("the Act"). The Panel imposed the following conditions on Dr Sawczuk's medical registration pursuant to s. 50(2)(e) and s. 51(2)(a) of the Act:

1. that he not self-prescribe Schedule 4 or Schedule 8 drugs;
2. that he not prescribe, administer or possess Schedule 8 drugs;
3. that he participate in the Victorian Doctors Health Program ("VDHP"), including in counselling, monitoring and support groups, for not less than 5 years, as directed by the Medical Director of the VDHP or his or her nominee;
4. that he submit to urine screening at his own expense as directed by the Deputy Chief Executive Officer of the Board for not less than 5 years and otherwise as directed by the Health Committee of the Board;
5. that he abide by the Board's protocol for urine analysis for not less than 5 years and otherwise as directed by the Health Committee of the Board;
6. that he initially work for no more than 20 hours per week and then as permitted in writing by the Health Committee of the Board;
7. that he provide to the Deputy Chief Executive Officer of the Board within 2 weeks and, as necessary thereafter, within two weeks of any change, the name of his treating general practitioner;
8. that he agree in writing to the Board within 2 weeks that the Board may communicate with his general practitioner and with the VDHP.

Dated 15 May 2003

JOHN H. SMITH
Deputy CEO

Subordinate Legislation Act 1994

NOTICE OF DECISION

Water (Lake Eildon Recreational Area)
(Houseboats) Regulations 2003

I, John Thwaites, Minister for Water and Minister responsible for the administration of the **Water Act 1989**, give notice under section 12 of the **Subordinate Legislation Act 1994**, as follows:

A Regulatory Impact Statement (RIS) was prepared in relation to the proposed Water (Lake Eildon Recreational Area) (Houseboats) Regulations 2003 to provide for the control and management of houseboat operation in the Lake Eildon Recreational Area. The RIS was advertised seeking public comment and a total of 9 submissions were received.

After considering these submissions, I have decided that the proposed Water (Lake Eildon Recreational Area) (Houseboats) Regulations 2003 should be made without amendment.

Dated 8 May 2003

JOHN THWAITES
Minister for Water

Transport Act 1983

TOW TRUCK DIRECTORATE OF VICTORIA

Tow Truck Application

Notice is hereby given that the following application will be considered by the Licensing Authority after 25 June 2003.

Notice of any objection to the granting of an application should be forwarded to reach the Director, Tow Truck Directorate of Victoria, Level 6, 14-20 Blackwood Street, North Melbourne (PO Box 666, North Melbourne 3051) not later than 19 June 2003.

It will not be necessary for interested parties to appear on the date specified, unless advised in writing.

R. Miller. Application for variation of conditions of tow truck licence number TOW708 which authorises the licensed vehicle to be managed, controlled and operated from a depot situated at 23 McDonald's Lane, Mulgrave to change the depot address to 10 Kirkham Road, Dandenong.

Dated 20 May 2003

STEVE STANKO
Director

Education Act 1958

NOTICE OF MAKING OF ORDERS UNDER SECTION 13 AND ADMINISTRATIVE ARRANGEMENTS ORDER (No. 180) 2002

Two Orders of the Minister for Education Services were made on 8 May 2003 under Sections 13(4), and 13(11) of the **Education Act 1958** and Administrative Arrangements Order (No. 180) 2002 amending the constituting

Orders of Benalla Primary School Council and Broken Creek Primary School Council in respect of the memberships of the school councils.

JACINTA ALLAN
Minister for Education Services

Education Act 1958

NOTICE OF MAKING OF AN ORDER
UNDER SECTION 13 AND
ADMINISTRATIVE ARRANGEMENTS
ORDER (No. 180) 2002

An Order of the Minister for Education Services was made on 8 May 2003 under Sections 13(4), 13(5) and 13(11) of the **Education Act 1958** and Administrative Arrangements Order (No. 180) 2002 dissolving the Mount Moriac Primary School Council (the Council) and providing that the Moriac Primary School Council shall have all the duties, powers and functions of the Council, and that all property, rights, liabilities and obligations of the Council become those of the Moriac Primary School Council.

JACINTA ALLAN
Minister for Education Services

Education Act 1958

NOTICE OF MAKING OF AN ORDER
UNDER SECTION 13 AND
ADMINISTRATIVE ARRANGEMENTS
ORDER (No. 180) 2002

An Order of the Minister for Education Services was made on 8 May 2003 under Sections 13(4), 13(5) and 13(11) of the **Education Act 1958** and Administrative Arrangements Order (No. 180) 2002 dissolving the Harrow Primary School Council and making interim arrangements for the membership of the school council and the disposal of the assets of the school council in the period prior to its dissolution.

JACINTA ALLAN
Minister for Education Services

Education Act 1958

NOTICE OF MAKING OF ORDERS UNDER
SECTION 13 AND ADMINISTRATIVE
ARRANGEMENTS ORDER (No. 180) 2002

Four Orders of the Minister for Education Services were made on 8 May 2003 under Sections 13(4), 13(5) and 13(11) of the

Education Act 1958 and Administrative Arrangements Order (No. 180) 2002 dissolving the Mudgegonga Primary School Council, Tatura East Primary School Council, Wareek Primary School Council and Yan Yean Primary School Council, and making interim arrangements for the memberships of the school councils and the disposal of the assets of the school councils in the period prior to their dissolution.

JACINTA ALLAN
Minister for Education Services

Education Act 1958

NOTICE OF MAKING OF AN ORDER
UNDER SECTION 13 AND
ADMINISTRATIVE ARRANGEMENTS
ORDER (No. 180) 2002

An Order of the Minister for Education Services was made on 12 May 2003 under Section 13(4) of the **Education Act 1958** and Administrative Arrangements Order (No. 180) 2002 dissolving the school council of the State school called Ewing House School for Deaf Children.

JACINTA ALLAN
Minister for Education Services

Education Act 1958

NOTICE OF MAKING OF ORDERS UNDER
SECTION 13 AND ADMINISTRATIVE
ARRANGEMENTS ORDER (No. 180) 2002

Seven Orders of the Minister for Education Services were made on 8 May 2003 under Sections 13(4), and 13(11) of the **Education Act 1958** and Administrative Arrangements Order (No. 180) 2002 amending the constituting Orders of Branxholme-Wallacedale Community School Council, Cann River P-12 College Council, Echuca South Primary School Council, Horsham North Primary School Council, Lockwood South Primary School Council, school council of the State school proposed to be called Meadowbank Primary School and Nowa Nowa Primary School Council in respect of the memberships of the school councils and also, in respect of Horsham North Primary School Council, making minor amendments to the name of the school council and the school.

JACINTA ALLAN
Minister for Education Services

Education Act 1958NOTICE OF MAKING OF ORDERS UNDER SECTION 13 AND ADMINISTRATIVE
ARRANGEMENTS ORDER (No. 180) 2002

Two Orders of the Minister for Education Services were made on 8 May 2003 under Sections 13(4), and 13(11) of the **Education Act 1958** and Administrative Arrangements Order (No. 180) 2002 amending the constituting Orders of Bealiba Primary School Council and Ripponlea Primary School Council in respect of the memberships of the school councils.

JACINTA ALLAN
Minister for Education Services

Education Act 1958NOTICE OF MAKING OF ORDERS UNDER SECTION 13 AND
ADMINISTRATIVE ARRANGEMENTS ORDER (No. 180) 2002

Four Orders of the Minister for Education Services were made on 14 May 2003 pursuant to Sections 13(4), and 13(11) of the **Education Act 1958** and Administrative Arrangements Order (No. 180) 2002 each amending the constituting Order of a school council to change its name. The changes are as follows:

Old name	New name
Sale Special Developmental School Council	Sale Specialist School Council
Sandringham Secondary College Council	Sandringham College Council
Sebastopol Secondary College Council	Sebastopol College Council
Upfield Secondary College Council	Roxburgh College Council

JACINTA ALLAN
Minister for Education Services

Crown Land (Reserves) Act 1978ORDER GIVING APPROVAL TO GRANT OF A LEASE UNDER SECTIONS 17D
AND 17DA

Under sections 17D and 17DA of the **Crown Land (Reserves) Act 1978**, I, Mary Delahunty, Minister for Planning, being satisfied that there are special reasons which make the granting of a lease reasonable and appropriate in the particular circumstances and to do this will not be substantially detrimental to the use and enjoyment of any adjacent land reserved under the **Crown Land (Reserves) Act 1978**, approve the granting of a lease by the Hindmarsh Shire Council for 21 years over the area of Crown land described in the Schedule below and, in accordance with section 17D(3)(a) of the **Crown Land (Reserves) Act 1978**, state that –

- (a) there are special reasons which make granting the lease reasonable and appropriate in the particular circumstances; and
- (b) to do this will not be substantially detrimental to the use and enjoyment of any adjacent land reserved under the **Crown Land (Reserves) Act 1978**.

SCHEDULE

The land shown by hatching on the attached plan, being the whole of the area known as the Nhill Caravan Park being land temporarily reserved for Public Park in the Township of Nhill, Parish of Balrootan, by Order in Council of 19 January 1971 published in the Government Gazette 27 January 1971 page 225.

NHILL CARAVAN PARK

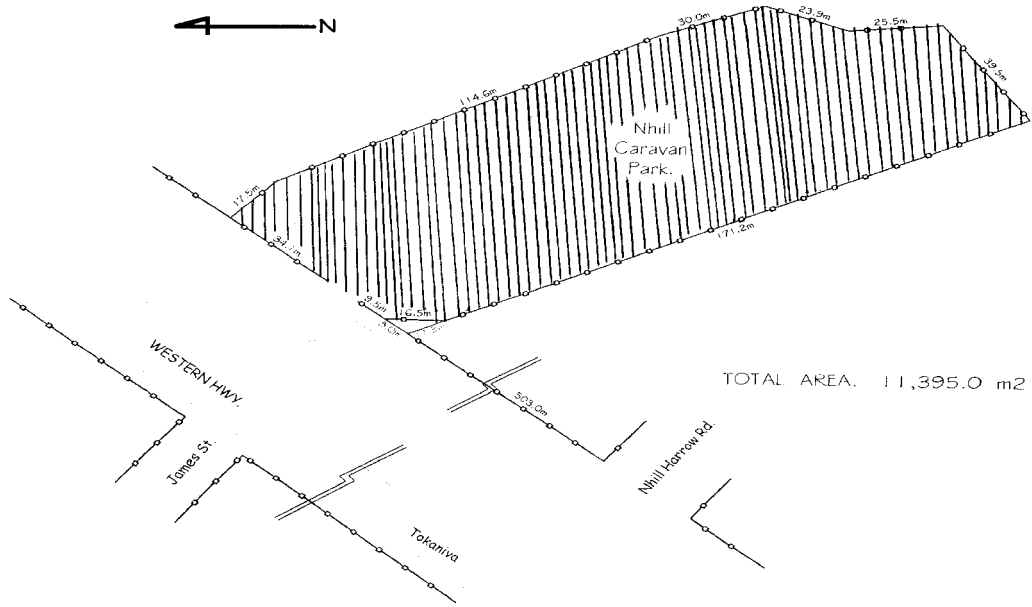

Dated 6 May 2003

MARY DELAHUNTY MP
Minister for Planning

Geographic Place Names Act 1998

NOTICE OF REGISTRATION OF GEOGRAPHIC NAMES

The Registrar of Geographic Names hereby gives notice of the registration of the undermentioned place names.

File No.	Place Name	Proposer & Location
GPN531	Burnley Street	Yarra City Council. Tram stop on Victoria Street at Burnley Street, Richmond.
GPN 532	River Boulevard	Yarra City Council. Tram stop on Victoria Street at River Boulevard, Richmond.

Office of the Registrar of Geographic Names
c/-LAND VICTORIA
15th Floor,
570 Bourke Street,
Melbourne 3000

KEITH C. BELL
Registrar of Geographic Names

Casino Control Act 1991—Section 60(1)
CASINO RULES NOTICE NO. 10 OF 2003
Rules of the Game—Blackjack

By this notice, the Victorian Casino and Gaming Authority amends the Rules in respect of the game “Blackjack”¹ as set out in the Schedule.

This notice operates with effect from 6.00am 23 May 2003.

Dated 16 May 2003

PETER COHEN

Acting Director of Gaming and Betting

Acting Director of Casino Surveillance

Schedule

Insertion

For the rules of the game of Blackjack between rule 9.8 (a) and rule 10, **insert** —

- 9.9 In the event that the cards are not shuffled following the exposure of the cutting card in accordance with rule 4.1.1 (b) and (c), a shuffle will take place immediately at the completion of the round of play.
- 9.10 If there are insufficient cards remaining in the dealing shoe to complete a round of play, all of the cards in the discard holder will be shuffled and cut in accordance with rule 4.1 and 4.2 and the Dealer will then complete the round of play and the game will continue in accordance with these rules.
- 9.11 If during a round of play the automatic shuffling/dealing shoe malfunctions and that round cannot be completed, that round of play will be void.
- 9.12 If during a round of play two or more cards are dealt from the automatic shuffling/dealing shoe simultaneously and the order of the cards cannot be determined, that round of play will be void.

1 The game of Blackjack and its rules were approved by notices published in the Victoria Government Gazette on 24 April 1997 (S44). The rules have subsequently been amended by—

- A notice dated 30 April 1998 (published in Victoria Government Gazette G17);
- Casino Rules Notice No. 1 of 1999 published on 18 March 1999 (S39);
- Casino Rules Notice No. 13 of 1999 published on 13 August 1999 (S121);
- Casino Rules Notice No. 18 of 1999 published on 9 September 1999 (S136);
- Casino Rules Notice No. 23 of 1999 published on 22 October 1999 (S156);
- Casino Rules Notice No. 24 of 1999 published on 4 November 1999 (S161);
- Casino Rules Notice No. 27 of 1999 published on 16 December 1999 (S183);
- Casino Rules Notice No. 3 of 2000 published on 17 March 2000 (S32);
- Casino Rules Notice No. 10 of 2000 published on 19 May 2000 (S68);
- Casino Rules Notice No. 15 of 2000 published on 11 June 2000 (S103);
- Casino Rules Notice No. 22 of 2000 published on 18 October 2000 (S147);
- Casino Rules Notice No. 26 of 2000 published on 7 December 2000 (S184);
- Casino Rules Notice No. 27 of 2000 published on 7 December 2000 (S184);
- Casino Rules Notice No. 28 of 2000 published on 7 December 2000 (S184);
- Casino Rules Notice No. 1 of 2001 published on 1 February 2001 (S9);
- Casino Rules Notice No. 21 of 2001 published on 18 October 2001 (G42);
- Casino Rules Notice No 1 of 2002 published on 3 January 2002(G1);
- Casino Rules Notice No 2 of 2002 published on 7 March 2002(S42);
- Casino Rules Notice No 14 of 2002 published on 24 May 2002 (S85);
- Casino Rules Notice No 27 of 2002 published on 7 August 2002 (S136) and
- Casino Rules Notice No.1 of 2003 published on 5 February 2003 (S18).

- 9.13 If during the course of play it is found that the deck/s in play do not contain the correct cards used to form the approved deck/s for the particular version of Blackjack in play:
- 9.13.1 The result of any rounds of play previously completed will stand;
 - 9.13.2 The round of play where the error is discovered will be declared void and all monies returned for that round of play; and
 - 9.13.3 The remainder of the shoe will be declared void and the cards removed from play.
-

Casino Control Act 1991—Section 60(1)
CASINO RULES NOTICE NO. 11 OF 2003
Rules of the Game—Lucky Streak

By this notice, the Victorian Casino and Gaming Authority amends the Rules in respect of the game “Lucky Streak”¹ as set out in the Schedule.

This notice operates with effect from 6.00am on 23 May 2003.

Dated 16 May 2003

PETER COHEN

Acting Director of Gaming and Betting

Acting Director of Casino Surveillance

Schedule

In rules of the game of Lucky Streak, for the definition of the terms, “Collect” and “Continue” **substitute** —

“Collect” means that with respect to a particular wager placed by a player, that player elects to exit from a round of play. The wager will be paid at the odds payable for the current streak level reached. The player will take no further part in subsequent action rounds unless he/she still has one or more unresolved wagers.

“Continue” means that with respect to a particular wager placed by a player that player elects to remain in a round of play and that his/her wager will remain active. By electing to continue the player is risking the odds payable for the current streak level reached. If the wager loses it is paid the applicable guaranteed payout.

At rule 7.4.1 (e) (i) and (ii) **substitute** —

- (e) Commencing with the first player with an active wager closest to his/her left, give each player in turn the opportunity to continue or collect. The player will indicate his/her decision as follows:
- (i) “Collect” by making a horizontal movement of the hand.
 - (ii) “Continue” by scratching or tapping the layout.
-

¹ The game of Lucky Streak and its rules were approved by notice published in the Victoria Government Gazette on 3 April 2003 (G 14).

Casino Control Act 1991—Section 60(1)
CASINO RULES NOTICE NO. 12 OF 2003
Rules of the Game—Roulette

By this notice, the Victorian Casino and Gaming Authority amends the Rules in respect of the game “Roulette”¹ as set out in the Schedule.

This notice operates with effect from 4.00am on 23 May 2003.

Dated 16 May 2003

PETER COHEN

Acting Director of Gaming and Betting

Acting Director of Casino Surveillance

Schedule

Amendment of Rules

1. In rule 1.2 **replace** current rule with —
 - 1.2 For the purpose of these rules the use of the term “chips” shall also mean and include “jetons” and “plaques” and on-screen chips used to place wagers on TouchBet Roulette.
2. After rule 10.3.5 (b) **insert** —
 - 11 TouchBet Roulette**
 - 11.1 Where the version of Roulette in play is “TouchBet Roulette” the approved rules of Roulette will apply, except where the rules are inconsistent with the rules of “TouchBet Roulette”, in which case the rules of “TouchBet Roulette” will prevail.
 - 11.2 Additional Definitions**

“**game system**” means the configuration of the game server, table console and two winning number sensors—

 - (a) Necessary to conduct the game; and
 - (b) Approved as gaming equipment for the purposes of these rules-

“**TouchBet Chip Account**” means an account established under rule 11.7.

“**TouchBet Betting Station**” means an automated transaction station featuring a touch screen monitor—

 - (a) Designed to allow a player to place wagers on a virtual Roulette layout in accordance with these rules; and
 - (b) Approved as an item of gaming equipment;

“**wagering period**” means the period in which players may place wagers as described in 11.6.2.

 - 11.3 Equipment**
 - 11.3.1 The display of the touch screen monitor of an open TouchBet Betting Station-
 - (a) Must—
 - (i) Contain all the elements of the design set out in Diagram L or M; and

¹ The Game of **Roulette** and its rules were approved by notice published in the Victoria Government Gazette on 24 April 1997 (S44). The rules have subsequently been amended by-

- Casino Rules Notice No. 11 of 1999, published on 6 August 1999 (S114);
- Casino Rules Notice No. 4 of 2000, published on 13 April 2000 (S46),
- Casino Rules Notice No. 16 of 2000, published on 11 July 2000 (S103); and
- Casino Rules Notice No 16 of 2000, published on 13 December 2001 (G50).

- (ii) Contain any additional elements necessarily required by these rules; and
 - (iii) Be of similar appearance to Diagram L or M; and
 - (b) May include features in addition to those shown in Diagram L or M, if those features are not inconsistent with Diagram L or M or these rules.
- 11.3.2 A TouchBet Roulette table is made up of the following equipment—
- (a) Up to 50 betting stations; and
 - (b) A game system; and
 - (c) One or more cameras; and
 - (d) A roulette wheel; and
 - (e) A roulette layout; and
 - (f) A roulette ball.

11.4 Placement of wagers

- 11.4.1 A wager in respect of an individual spin is placed by a person appropriating money standing to the credit of a player's TouchBet Chip Account to a particular bet (as specified in rule 6.1) in the manner shown in Diagram C or K prior to the end of the wagering period for that spin.
- 11.4.2 The method by which a person appropriates money standing to the credit of a player's TouchBet Chip Account is by touching the display of the TouchBet betting screen so as—
- (a) To make one or more chips appear to move from one part of the display to another; or
 - (b) To make one or more chips appear on, or disappear from, the display with a corresponding change being made to the amount shown as standing to the credit of the player's TouchBet Chip Account.
- 11.4.3 The player in control of a TouchBet Screen is solely responsible for the placement of the chips appearing on that screen.
- 11.4.4 The wager or wagers placed on a TouchBet Screen may only be settled in accordance with the appearance of the TouchBet Screen at the time a wagering period expires.
- 11.4.5 A TouchBet Screen must not allow a wager to be placed, changed or withdrawn after the expiry of the wagering period.
- 11.4.6 At the settlement of wagers for a spin, each open TouchBet Screen must—
- (a) Clear any losing wager, by causing the chips representing that wager to disappear from the display; and
 - (b) Pay any winnings, by causing an appropriate number of chips to appear or by causing an appropriate adjustment to be made to the amount shown as standing to the credit of the player's TouchBet Chip Account.
- 11.4.7 Wagers may only be placed in accordance with rule 11.4.

11.5 Permissible Wagers

- 11.5.1 In respect of the game, the Dealer must ensure the display of the notices and signs for which the casino operator is responsible under section 66(1)(d) and section 66(2) of the **Casino Control Act 1991**².
- 11.5.2 Each TouchBet Betting Station is a location within the casino for the purposes of section 66(1)(d) and section 66(2) of the **Casino Control Act 1991**.
- 11.5.3 If—
- (a) A player attempts to place an individual wager that is less than the minimum permissible wager for a particular bet, the TouchBet Screen must not display any chips in respect of that wager; and
 - (b) A player attempts to place an individual wager—
 - (i) In a multiple over the minimum which is not permitted; or
 - (ii) Which is greater than the permitted maximum wager—
 the TouchBet Screen must display only so many chips or such denomination of chips as is the next lowest permitted wager; and
 - (c) By the end of the wagering period for an individual spin, a player has placed one or more wagers which are in aggregate less than the permitted aggregate wager (if any), those wagers must not be recognised by the TouchBet Screen or the game system for the individual spin.

11.6 Dealing the Game

- 11.6.1 The Dealer will deal the game in accordance with rule 5.1.
- 11.6.2 For each round of play, each TouchBet Screen must clearly display:
- (a) The period in which a player may place a wager;
 - (b) A warning that the wagering period is about to end; and
 - (c) When the wagering period has ended.
- 11.6.4 When the ball has come to rest in a compartment around the wheel:
- (a) The outcome of the spin must be displayed on each open TouchBet Screen; and
 - (b) In respect of the wager or wagers placed on a TouchBet Screen—
 - (i) If an amount has been won, automatically calculate and display the amount; and
 - (ii) Automatically calculate and display the balance of the TouchBet Chip Account as a result of the outcome—
 in accordance with these rules.

2 Sections 66(1)(d) and 66(2) of the **Casino Control Act 1991** state:

66. Assistance to patrons

- (1) A casino operator must ensure that-

...

- (d) there is prominently displayed at each gaming table or location related to the playing of a game a sign indicating the permissible minimum and maximum wagers pertaining to the game played there.
- (2) A casino operator must ensure that a minimum wager indicated in respect of a game at a table or location is not changed to a higher minimum unless a sign indicating the new minimum and the proposed time of change is displayed at the table or location at least 20 minutes before the time of proposed change.

Penalty: 50 penalty units.

11.7. TouchBet Chip Accounts

- 11.7.1 An open TouchBet Screen must display the active TouchBet Chip Account for the TouchBet Screen.
- 11.7.2 A person wishing to play the game must buy in by inserting an amount of cash into the TouchBet Note Acceptor.
- (a) Where a player inserts cash into a TouchBet Note Acceptor, the amount of cash will automatically be credited to the TouchBet Chip Account in respect of that TouchBet Betting Station, thereby causing chips to appear on the display of the TouchBet Screen or that amount to be shown as standing to the credit of the TouchBet Chip Account.
- 11.7.3 The person for the time being in control of an open TouchBet Screen may at any time insert a further amount of cash into the TouchBet Note Acceptor.
- 11.7.4 A player—
- (a) May leave the game at any time; and
- (b) Must leave the game if the Dealer or above, having reasonably formed the opinion that the player's continued presence would disrupt the game and thereby compromise its integrity, directs the player to leave the game.
- 11.7.5 When a player leaves the game to close the TouchBet Chip Account he/she selects Cash-Out. Where the Touch Bet Chip Account balance is zero, he/she may leave the game at anytime.

11.8 Settlement

- 11.8.1 The bets which can be placed in respect of an individual spin and the odds payable for them are described in rule 6.1.

11.9 Irregularities

- 11.9.1 If the Dealer reasonably forms the view that an incorrect outcome has been recorded by the TouchBet game system, the Dealer must notify the Game Supervisor who will adjust the outcome in the game system and cause the results to be recalculated based on the actual outcome.
- 11.9.2 If a player claims that an incorrect outcome has been recorded by the TouchBet game system or that any part of the game system has malfunctioned, the claim must be considered and whatever reasonable action permitted by this rule must be taken.
- 11.9.3 If the game system (other than a TouchBet Betting Station) experiences a malfunction (including by reason of physical damage)—
- (a) Prior to the expiry of the wagering period, all wagers placed on the TouchBet Screen/s for the relevant spin must be treated as void; and
- (b) On or after the expiry of the wagering period, the exact wagers placed must be confirmed through the analysis of available records and the appropriate adjustments must be made.
- (i) The Casino Operator may refuse to pay any amount claimed in respect of a particular TouchBet Betting Station for a period of seventy two hours to allow the Casino Operator to investigate the malfunction.

- 11.9.4 A TouchBet Betting Station will be considered to have malfunctioned where
- (a) An amount credited to the TouchBet Chip Account Balance is not in keeping with the odds payable for winning wagers as stated in rule 6.1 and the amount wagered; or
 - (b) The TouchBet Screen displays numbers not in keeping with the game format; or
 - (c) The normal playing sequence of the TouchBet Betting Station is permanently interrupted or the normal display is faulty; or
 - (d) For any other reason the Casino Operator is of the opinion that the TouchBet Betting Station is not functioning correctly.
- 11.9.5 If a TouchBet Betting Station experiences a malfunction—
- (a) Prior to the expiry of the wagering period, all wagers placed on the TouchBet Screen for the relevant spin must be treated as void; and
 - (b) On or after the expiry of the wagering period, the exact wagers placed must be confirmed through the analysis of available records and the appropriate adjustments must be made.
 - (i) The Casino Operator may refuse to pay any amount claimed in respect of a particular TouchBet Betting Station for a period of seventy two hours to allow the Casino Operator to investigate the malfunction.
- 11.9.6 If for the purposes of rules 11.9.3(b) and 11.9.5(b), the relevant wagers placed cannot be confirmed through the analysis of available records, then those wagers must be treated as void.
- 11.9.7 Where in the opinion of the Casino Operator an amount has been credited to a player's TouchBet Chip Account-
- (a) As a result of a TouchBet Betting Station or game system malfunction; or
 - (b) After a TouchBet Betting Station or game system has malfunctioned and before their repair, then
- The Casino Operator may refuse to pay or credit the player's TouchBet Chip Account Balance with the amount.

After diagram "K" **insert** diagrams "L" and "M":

Diagram L

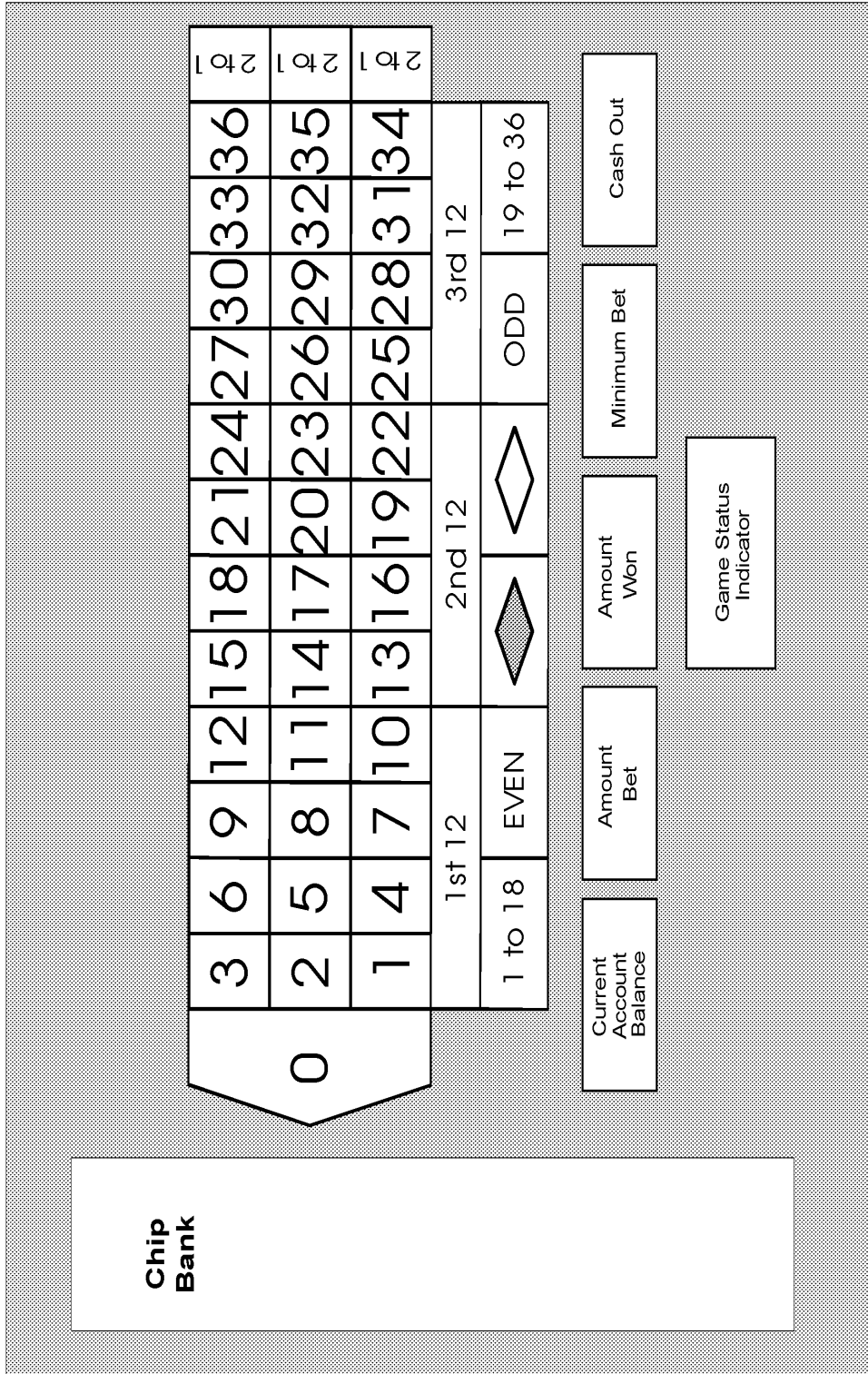
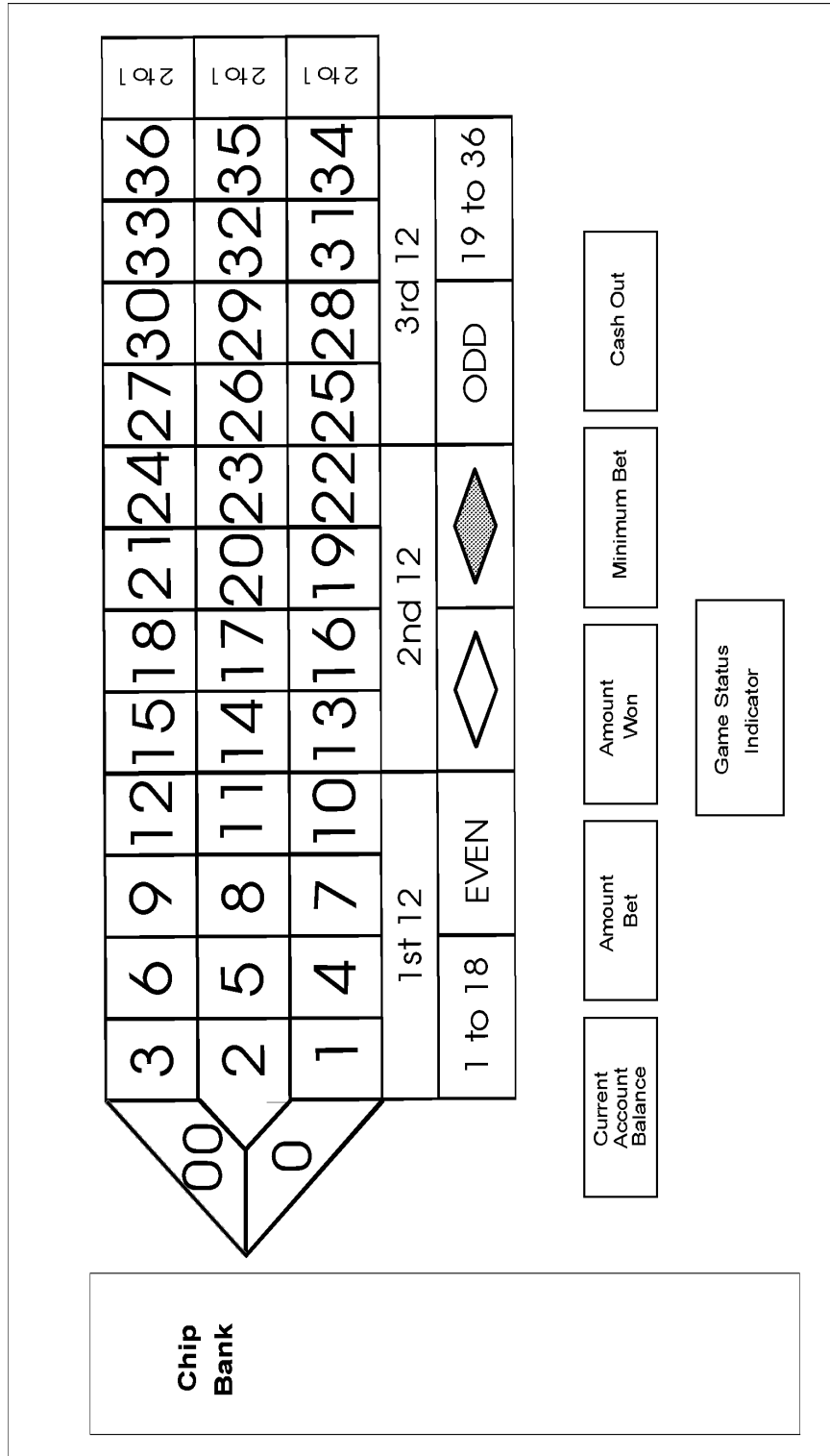

Diagram M



Occupational Health and Safety Act 1985
VICTORIAN WORKCOVER AUTHORITY

Notice of Issue of Major Hazard Licence

On 2 May 2003, a licence under Part 8 of the Occupational Health and Safety (Major Hazard Facilities) Regulations 2000 was issued to Shell Refining (Australia) Pty Ltd, Refinery Road, Corio, Victoria 3214 and authorises the LPG Terminal facility located at 305 Hendy Street, Lara, Victoria, to be operated as a major hazard facility.

The Major Hazard Facility Licence was issued for a term of 5 years and will expire on 8 April 2008.

The licence did not include conditions.

The following Schedule 1 materials were authorised by the licence:

From Table 1 of Schedule 1

Material	UN Nos included or excluded under name
LP Gases	1011,1978
Ammonia Anhydrous	1005

From Table 2 of Schedule 1

Material	Description
Compressed and liquefied gases	Compressed or liquefied gases of Class 2.1

GREG TWEEDLY
 Chief Executive

STATE OF VICTORIA

Petroleum (Submerged Lands) Act 1982

NOTICE OF GRANT OF EXPLORATION PERMIT

A permit numbered VIC/P38(V) has been granted to Benaris Energy NV, Usaba Tegas Sdn BHD, Level 43, Menara Maxis, Kuala Lumpur City Centre 50088, Kuala Lumpur, Malaysia in respect of the blocks described hereunder, to have effect for a period of six years from and including 12 May 2003.

DESCRIPTION OF BLOCKS

The graticular blocks numbered hereunder –

BLOCK NO.	BLOCK NO.	BLOCK NO.	BLOCK NO.
2292 (part)	2293 (part)	2294 (part)	2364 (part)
2365 (part)	2266 (part)	2167 (part)	2438 (part)
2439 (part)	2440 (part)	2441 (part)	2442 (part)
2513 (part)	2514 (part)		

on the Hamilton SJ54 Offshore Graticular Sections Map.

Dated 12 May 2003

Made under the **Petroleum (Submerged Lands) Act 1982**
 of the State of Victoria.

RICHARD ALDOUS
 Executive Director Minerals and Petroleum
 Delegate of the Minister for Resources

ABSTRACTS OF ACCOUNTS : 1 JANUARY 2001 - 31 DECEMBER 2001
ABSTRACTS OF ACCOUNT PUBLIC CEMETERY TRUSTS 2001 Published in compliance with the requirements of Section 34 of the **Cemeteries Act 1958**

Cemetery Trust	Balance at Bank 1/1/2001	Fees for Graves	Other Sources of Income	Income as shown general account - Abstract	Salaries & Wages-Secretary	Office Expenses including Insurance	Works and Building	Staircases	Balance at Bank 31/12/2001	Expenditure as per Abstract
ABERDEEN	479.57	600.00	131.67	0.00	0.00	27.50	200.00	0.00	983.74	1211.24
ADASS ISRAEL	27750.00	1875.00	10003.00	34666.00	43620.00	906.00	605.00	0.00	28733.00	34606.00
ALBERTON	6654.54	780.00	12184.7	8633.01	464.00	594.5	4396.03	0.00	3663.53	8633.01
ALEXANDRA	13174.68	20822.74	29487.72	63483.14	182099.5	1066.59	290.25	38840.23	49181.2	63483.14
ALMA	Nil Return	0.00	0.00	0.00	Nil Return	0.00	0.00	0.00	0.00	0.00
ALTONA MEMORIAL PARK	197768.00	329230.00	5784870.00	9271988.00	1458940.00	314488.00	23982.00	7060164.00	18521000	9271988.00
AMHERST	8596.00	3009.00	6133	11666.33	1250.00	0.00	1892.17	0.00	8404.41	11666.33
AMPHITHEATRE	8670.11	951.00	4519.58	6337.59	96.45	0.00	197.35	469590	134789	6337.59
ANDERSONS CREEK (Warrambulo)	21742.48	54933.30	186071.38	244083.16	260784.31	12349.82	2624.85	2100415.10	10593298	244083.16
ANTWERP	3360.93	0.00	1022.98	1375.91	0.00	0.00	0.00	1600.33	375.56	1375.91
APOLLO BAY	19852.04	21656.04	665384	4816592	1406340	0.00	5572.04	1889053	983945	4816592
APSLEY	Abstract Not Submitted	0.00	0.00	0.00	Abstract Not Submitted	0.00	0.00	0.00	0.00	0.00
ARARAT	25055.12	54238.21	34172.40	1346573	41744.3	2357.45	3596.39	3645906	2987838	1346573
ARTHURS CREEK	4610684	14878.96	82387.01	143372.81	5462.75	0.00	500.89	8221281	909645	143372.81
ASHENS	1479.09	0.00	11.11	149080	0.00	0.00	0.00	0.00	0.00	149080
AVENEL	Abstract Not Submitted	0.00	0.00	0.00	Abstract Not Submitted	0.00	0.00	0.00	0.00	0.00
AYCKA	5751.87	147083.00	9891.57	21892.44	6457.50	0.00	342.85	1085975	1133.34	21892.44
BAIRNSDALE	26471.00	64300.00	218741.00	392295.00	118411.00	0.00	27481.00	18875000	86288.00	392295.00
BALARAAT GENERAL	0.00	130180.00	1068846.00	2575026.00	611780.00	197272.00	437916.00	1342084.00	63540.00	2575026.00
BALAN	4837.28	0.00	83.45	12511.94	26301.1	486.06	200.00	612238	37531	12511.94
BALLANGREIGH	2673.8	0.00	450.41	717.79	0.00	0.00	0.00	60.50	457.29	717.79
BALMORAL	226234	1990.00	451253	876487	116500	900	185.50	460660	298427	876487
BAMBERA	786.22	0.00	79902	0.00	0.00	0.00	0.00	13.50	540.22	786.22
BANNERTON (Tot Tot)	926.49	0.00	0.61	927.10	0.00	0.00	0.00	0.00	927.10	927.10
BANNOCKBURN	3081.31	1990.00	8990.98	10450.39	631.95	0.00	626.10	547083	3701.51	10450.39
BARNHURUP	2131.07	0.00	11.54	2142.61	0.00	0.00	0.00	23081	191180	2142.61
BARKLY	Abstract Not Submitted	0.00	0.00	0.00	Abstract Not Submitted	0.00	0.00	0.00	0.00	0.00
BARMAH	6166.03	448.00	9999.90	7613.93	13000	1000	100.00	227	7571.66	7613.93
BARNAWARITHA	7127.50	1691.00	176.86	82953.6	9600.00	0.00	106.75	122.00	78966.61	82953.6
BEALIBA	8463.10	1718.00	1056.54	11217.64	9000.00	0.00	264.00	1588.50	8525.14	11217.64
BEALFORD	19850.03	15238.20	249626.63	607948	3832.17	0.00	874.12	3827708	130965.1	607948
BEAC	0.00	135.00	5338.51	5373.51	0.00	0.00	0.00	0.00	5373.51	5373.51
BELCHWORTH	12821.55	25390.00	584533.6	947969.1	153040.00	1692.44	12995.57	52087.24	1211766	947969.1
BENAC	8999.27	2447.00	10660.47	21806.74	176000	0.00	0.00	10964.16	9082.58	21806.74
BELLBRAE	3495.00	14629.00	19025.00	37147.00	142660.00	107500.00	0.00	18242.00	3840.00	37147.00
BELLELIEN	Nil Return	0.00	0.00	0.00	Nil Return	0.00	0.00	0.00	0.00	0.00
BENALLA	30389.36	85445.93	-1659.71	114175.58	77853.21	32856.69	4382.92	548.56	279052.0	114175.58
BENAMBRA	593.572	743.00	2017.00	86957.2	38.00	93.50	16.54	0.00	8227.68	86957.2
BENDIGO	70445.00	864691.00	990890.00	1584725.00	512640.00	131125.00	241500.00	646680.00	2992.00	1584725.00
BENDOC	1242.90	0.00	0.00	1242.90	0.00	0.00	0.00	0.00	1242.90	1242.90
BERRIWILLOCK	397.08	1680.00	2308.50	6385.58	13000.00	0.00	0.00	256.00	2779.38	6385.58
BERWICK	32177.61	92834.63	888207.00	513219.24	468896.60	7409.1	10561.03	4346397	27163.73	513219.24
BETHANGA	1431.46	0.00	1411.50	5576.56	0.00	0.00	0.00	1500.72	408384	5576.56
BELLAIH	33671.5	3660.00	102263.3	178534.8	1221.10	8184	0.00	10255.00	6455.54	178534.8
BERRIP	5123.24	5766.56	6823.56	17715.36	51660.00	88604.1	1735.13	88604.1	199180	17715.36
BERRIGURRA	5196.54	345.00	0.00	3481.54	0.00	0.00	0.00	0.00	3481.54	3481.54
BLACKHEATH (Sailors Home)	Nil Return	0.00	0.00	0.00	Nil Return	0.00	0.00	0.00	0.00	0.00
BLACKWOOD	7211.95	4192.15	1914	11423.22	1221.00	3000.00	1750.14	213.39	7986.69	11423.22
BLEAK HOUSE	1616.22	55.00	0.74	1671.96	0.00	0.00	0.00	0.00	12.44	1671.96
BLJEMOUNTAIN	Abstract Not Submitted	0.00	0.00	0.00	Abstract Not Submitted	0.00	0.00	0.00	0.00	0.00
BOINKA	623.00	0.00	0.40	623.40	0.00	0.00	0.00	0.00	623.40	623.40
BONNIEDOON	Nil Return	0.00	0.00	0.00	Nil Return	0.00	0.00	0.00	0.00	0.00

Cemetery Trust	Balance at Bank 1/1/2001	Fees for Graves	Other Sources of Income	Income as shown in general account - Abstract	Salaries & Wages; Secretary	Office Expenses including Insurance	Works and Building	Summies	Balance at Bank 31/12/2001	Expenditure as per Abstract
WALWA	242.77	43,000	2777.15	5640.92	0.00	0.00	60.00	2836.17	2744.75	5640.92
WANGARATTA	Abstract Not Submitted	0.00	0.00	Abstract Not Submitted	0.00	0.00	0.00	0.00	0.00	0.00
WARACOCURT (Shire of Colac-Onway)	6146.15	374.53	5.57	6526.25	363.40	0.00	0.00	493.64	5669.21	6526.25
WARRACKNABEAL	13020.90	2155.89	7286.03	41504.83	15617.50	0.00	1364.17	5383.99	6693.22	41504.83
WARRAGILL	1166.74	7876.94	63761.73	143693.37	64766.09	0.00	13494.98	40897.76	18395.65	143693.37
WARRINGAL	4298.00	367367.00	1040370.00	1372404.00	175703.00	0.00	32539.00	98600.00	1061242.00	1372404.00
WARRANBOOL	36413.63	183396.34	267731.93	487361.92	84007.88	0.00	6947.03	33301.06	79033.91	487361.92
WATCHEM	23676.06	1248.90	848.80	4403.76	1165.90	0.00	0.00	822.21	241565	4403.76
WATERLOO	862.34	5000	1032.29	1947.83	50.00	0.00	0.00	1000.30	897.33	1947.83
WAUVERA	Abstract Not Submitted	0.00	0.00	Abstract Not Submitted	0.00	0.00	0.00	0.00	0.00	0.00
WEDDERBURN	2268.03	1840.00	855.00	4963.03	910.00	0.00	14.32	100.00	3932.72	4963.03
WELSHMAN'S REEF	Abstract Not Submitted	0.00	0.00	Abstract Not Submitted	0.00	0.00	0.00	0.00	0.00	0.00
WELLSFPOOL	3896.77	900.00	4067.00	8863.77	540.00	0.00	0.00	3834.42	4469.35	8863.77
WERRIBE	99450.00	30570.50	917385.00	1322740.00	239488.00	0.00	7006.00	90957.00	166359.00	1322740.00
WERRIMULL	959.80	185.00	1135.80	1135.80	214.50	0.00	0.00	55.86	865.44	1135.80
WHITEFIELD	1807.36	1060.00	2557.56	5424.92	304.00	0.00	28.50	2500.00	2696.42	5424.92
WHERO PUBLIC CEMETERY	1738.01	0.00	1738.01	1738.01	0.00	0.00	0.00	0.00	1738.01	1738.01
WICKLIFFE	1263.72	0.00	2164.97	3430.69	323.00	0.00	0.00	2179.60	928.09	3430.69
WILBY (See Yarravongal & District)	Abstract Not Submitted	0.00	0.00	Abstract Not Submitted	0.00	0.00	0.00	0.00	0.00	0.00
WILLIAMS TOWN	606.39	1813.50	5302.08	7922.17	0.00	0.00	0.00	359.60	6739.26	7922.17
WILLAWARRA	Abstract Not Submitted	0.00	0.00	Abstract Not Submitted	0.00	0.00	0.00	0.00	0.00	0.00
WILLIAMSTOWN	5516.00	2462.34	181.15	7996.49	0.00	0.00	0.00	0.00	0.00	0.00
WILLOW GROVE	32136.33	73286.68	317.81	39982.82	873.00	0.00	0.00	4595.08	34412.35	39982.82
WINGHELSA SURF COAST SHIRE COUNCIL	566.94	0.00	0.54	567.48	0.00	0.00	0.00	0.00	567.48	567.48
WINNAM	4920.04	285.00	13.36	5218.40	0.00	0.00	0.00	0.00	5218.40	5218.40
WINTON	19220.73	148709.63	76691.80	243322.27	97715.12	0.00	1523.17	9871.29	37889.36	243322.27
WODENGA	13248.43	4093.60	1000.00	84310.05	41292.65	0.00	130.00	8236.44	29903.6	54310.05
WONTHAGGI	7492.74	19384.11	9082.37	36133.23	12975.00	0.00	0.00	3249.68	7886.83	10023.29
WOODS POINT	384.99	230.00	0.55	833.54	0.00	0.00	0.00	0.00	833.53	833.54
WOOLSTHORPE	Abstract Not Submitted	0.00	0.00	Abstract Not Submitted	0.00	0.00	0.00	0.00	0.00	0.00
WOOMELANG	533.96	181.00	2667.90	3382.86	15.00	0.00	0.00	0.00	0.00	0.00
WOORAK	Abstract Not Submitted	0.00	0.00	Abstract Not Submitted	0.00	0.00	0.00	0.00	0.00	0.00
WOORNDOO	254.61	0.00	0.24	254.85	0.00	0.00	0.00	0.00	254.85	254.85
WOOSANG	Abstract Not Submitted	0.00	0.00	Abstract Not Submitted	0.00	0.00	0.00	0.00	0.00	0.00
WUNGHNU	1856.11	1102680	16888.86	29771.77	10164.65	0.00	45.00	386.23	16187.71	29771.77
WYCHIEPROOF	1819.95	545.00	9.50	2374.45	220.00	0.00	0.00	0.00	2153.75	2374.45
YABBA	1043.39	6000	0.00	1108.39	0.00	0.00	10.60	329.00	763.79	1108.39
YACKANDANDAH	7876.64	13243.13	12636.96	33736.75	12285.92	0.00	40.43	434.07	20996.33	33736.75
YALCANGRITH	1652.69	860.00	4.40	2497.09	571.75	0.00	0.00	0.00	1921.68	2497.09
YALLOURN	23672.30	72307.99	234402.33	32582.82	48045.80	0.00	13968.04	73184.11	245000.00	32582.82
YAMBUK	Abstract Not Submitted	0.00	0.00	Abstract Not Submitted	0.00	0.00	0.00	0.00	0.00	0.00
YAN YAN	57018.60	207899.63	474136.08	786354.31	110161.40	0.00	3843.95	26384.586	3.88963.12	786354.31
YARCK	5.76	2330.00	18406.35	20742.11	0.00	0.00	330.00	27.30	6049.00	13221.37
YARRA GLEN	Abstract Not Submitted	0.00	0.00	Abstract Not Submitted	0.00	0.00	0.00	0.00	0.00	0.00
YARRAWONG	Abstract Not Submitted	0.00	0.00	Abstract Not Submitted	0.00	0.00	0.00	0.00	0.00	0.00
YARRAM	121139.09	3394098	61342.32	109622.39	27100.41	0.00	1123.85	67166.37	14231.76	109622.39
YARRAWONG & DISTRICT	25730.07	3016.00	41306.23	70032.30	1832.85	0.00	1493.30	54.5	31495.94	36548.76
YARRAVONE	3032.11	27000	0.00	3003.11	0.00	0.00	0.00	0.00	3002.11	3003.11
YAUHER	Abstract Not Submitted	0.00	0.00	Abstract Not Submitted	0.00	0.00	0.00	0.00	0.00	0.00
YEA	6788.20	1475083	25065.40	46604.43	1040.42	0.00	0.00	7420.70	20230.43	8912.88

Planning and Environment Act 1987

HOBSONS BAY PLANNING SCHEME

Notice of Approval of Amendment

Amendment C26

The Minister for Planning has approved Amendment C26 to the Hobsons Bay Planning Scheme.

The Amendment comes into operation on the date this notice is published in the Government Gazette.

The Amendment rezones the land at 1–29 Central Avenue, Altona Meadows from Residential 1 Zone to Business 1 Zone and replaces the schedule to the Business 1 Zone to increase the maximum combined Leasable Floor Area to 15,000 square metres at the Central Square Shopping Centre (described in the schedule as the land on “north side of Petre Avenue between Merton Street and the eastern boundary of the residential properties abutting Myers Parade”).

The Minister has granted the following permit under Division 5 Part 4 of the Act:

Permit No.: P01.655.

Description of land: 1–29 Central Avenue, Altona Meadows.

A copy of the Amendment and permit can be inspected, free of charge, during office hours, at the Department of Sustainability and Environment, Planning Information Centre, Upper Plaza, Nauru House, 80 Collins Street, Melbourne and at the offices of the Hobsons Bay City Council, 115 Civic Parade, Altona.

PAUL JEROME
Executive Director
Planning and Land Division
Department of Sustainability
and Environment

Planning and Environment Act 1987

GREATER SHEPPARTON

PLANNING SCHEME

Notice of Approval of Amendment

Amendment C26

The Minister for Planning has approved Amendment C26 to the Greater Shepparton Planning Scheme.

The Amendment comes into operation on the date this notice is published in the Government Gazette.

The Amendment:

- rezones 36-46 Casey Street, Tatura from Public Use 1 to Business 1;
- rezones 48 Casey Street, Tatura from Residential 1 to Business 1.

A copy of the Amendment can be inspected, free of charge, during office hours, at the Department of Sustainability and Environment, Planning Information Centre, Upper Plaza, Nauru House, 80 Collins Street, Melbourne, Department of Sustainability and Environment North Eastern regional office, 50-52 Clarke Street, Benalla and at the offices of the Greater Shepparton City Council, 90 Welsford Street, Shepparton.

PAUL JEROME
Executive Director
Planning and Land Division
Department of Sustainability
and Environment

Planning and Environment Act 1987

INDIGO PLANNING SCHEME

Notice of Approval of Amendment

Amendment C16

The Minister for Planning has approved Amendment C16 to the Indigo Planning Scheme.

The Amendment comes into operation on the date this notice is published in the Government Gazette.

The Amendment changes the existing zone on Crown Allotments 7A, 7C, and part 7 Section A1 and Crown Allotment 18, Section I, Parish of Beechworth which is part of the Wangaratta Farm Penal Purposes Reserve from Public Conservation and Resource Zone (PCRZ) to the Rural Use Zone (RUZ).

A copy of the Amendment can be inspected, free of charge, during office hours, at the Department of Sustainability and Environment, Planning Information Centre, Upper Plaza, Nauru House, 80 Collins Street, Melbourne, the North Eastern Regional Office, 50-52 Clarke Street, Benalla and at the offices of the Indigo Shire Council, High Street, Beechworth.

PAUL JEROME
Executive Director
Planning and Land Division
Department of Sustainability
and Environment

Planning and Environment Act 1987

WHITTLESEA PLANNING SCHEME

Notice of Approval of Amendment

Amendment C40

The Minister for Planning has approved Amendment C40 to the Whittlesea Planning Scheme.

The Amendment comes into operation on the date this notice is published in the Government Gazette.

The Amendment includes land located at Lot 3, 500–510 High Street, Epping in the Schedule to Clause 52.03 (Specific Sites and Exclusions) to enable the site to be used for a bicycle shop.

A copy of the Amendment can be inspected, free of charge, during office hours, at the Department of Sustainability and Environment, Planning Information Centre, Upper Plaza, Nauru House, 80 Collins Street, Melbourne and at the offices of the Whittlesea City Council, Ferres Boulevard, South Morang.

PAUL JEROME
Executive Director
Planning and Land Division
Department of Sustainability
and Environment

- deletes the Vegetation Protection Overlay from land within the O'Herns Road and Craigieburn Bypass interchange;
- corrects Schedule 2 to the Design and Development Overlay to provide the correct reference to the "Metropolitan Ring Road";
- rewords the Schedule to Clause 52.17 to correctly describe the Craigieburn Bypass area;
- updates the Schedule to Clauses 61.01–61.04 to include the maps inserted as part of this Amendment.

A copy of the Amendment can be inspected, free of charge, during office hours, at the Department of Sustainability and Environment, Planning Information Centre, Upper Plaza, Nauru House, 80 Collins Street, Melbourne, VicRoads, Planning Investigation Department, 60 Denmark Street, Kew and at the offices of the Whittlesea City Council, Ferres Boulevard, South Morang.

PAUL JEROME
Executive Director
Planning and Land Division
Department of Sustainability
and Environment

Planning and Environment Act 1987

WHITTLESEA PLANNING SCHEME

Notice of Approval of Amendment

Amendment C44

The Minister for Planning has approved Amendment C44 to the Whittlesea Planning Scheme.

The Amendment comes into operation on the date this notice is published in the Government Gazette.

The Amendment:

- introduces a Public Acquisition Overlay to land surrounding the O'Herns Road and Craigieburn Bypass intersection so that VicRoads can acquire the land for road construction purposes;
- deletes an area of Design and Development Overlay from land adjoining the O'Herns Road and Craigieburn Road intersection;

ORDERS IN COUNCIL

Livestock Disease Control Act 1994

ORDER DECLARING DISEASES AND EXOTIC DISEASES

The Governor in Council, acting under section 6 of the **Livestock Disease Control Act 1994** –

- (a) revokes the Orders made by the Governor in Council listed in Schedule 1; and
- (b) declares the contagious or infectious diseases and conditions listed in Schedule 2 to be diseases for the purposes of the Act; and
- (c) declares the contagious or infectious diseases and conditions listed in Schedule 3 to be exotic diseases for the purposes of the Act.

SCHEDULE 1

Revocations

Order	Date Order made by Governor in Council	Publication of Order in Government Gazette
Order declaring diseases and exotic diseases	19 January 1999	Published in Government Gazette No. G3 on 21 January 1999, page 121.
Order declaring Small Hive Beetle to be an exotic disease	8 November 2002	Published in Government Gazette No. G46 on 14 November 2002, page 3033

SCHEDULE 2

***Diseases**

*Section 3 definition of “disease”

Part A Diseases of Mammals and Birds

Anaplasmosis	Johne’s disease
Anthrax	
	Leptospirosis
Babesiosis	Listeriosis
Bovine brucellosis	
Bovine genital campylobacteriosis	Mucosal disease
Bovine malignant catarrh	
Bovine malignant tumour of the eye larger than 2cm	Ovine brucellosis
	Ovine footrot
Buffalo fly	Ovine ked
	Ovine lice
Caprine arthritis encephalitis	
Caprine footrot	Psittacosis
Cattle tick	Pullorum disease
Cervine footrot	
Cysticercosis (<i>C. bovis</i>)	Rabbit calicivirus disease
Enzootic bovine leucosis	Salmonellosis
Equine infectious anaemia	Swine brucellosis
Equine piroplasmiasis	
Equine viral abortion	Trichomoniasis

SCHEDULE 2 [continued – Diseases]

Equine viral arteritis	Tuberculosis
Infectious bovine rhinotracheitis	Verocytotoxigenic <i>E.coli</i>
Infectious laryngotracheitis	

Part B Diseases of Bees

American foul brood disease	European foul brood disease
Braula fly (<i>Braula coeca</i>)	Nosema (<i>Nosema apis</i>)
Chalk brood disease	Small hive beetle

Part C Diseases of Fish**Diseases of Fin Fish**

Epizootic haematopoietic necrosis
Aeromonas salmonicida – atypical strains

Diseases of Molluscs

Bonamiosis (*Bonamia* species)

SCHEDULE 3***Exotic Diseases**

Section 3 definition of “exotic disease”

Part A Exotic Diseases of Mammals and Birds

African horse sickness	Infectious bursal disease (hypervirulent form)
African swine fever	Japanese encephalitis
Aujeszky's disease	Jembrana disease
Avian influenza	Louping ill
Australian lyssaviruses including bat lyssavirus	Lumpy skin disease
Bluetongue	Maedi-visna
Borna disease	Menangle virus (porcine paramyxovirus)
Bovine spongiform encephalopathy	Nairobi sheep disease
<i>Brucella canis</i>	Newcastle disease
<i>Brucella melitensis</i>	Nipah virus
Chagas disease	Peste des petits ruminants
Classical swine fever	Porcine reproductive and respiratory syndrome
Contagious equine metritis	Pig reproductive disease
Contagious bovine pleuropneumonia	Potomac fever
Contagious caprine pleuropneumonia	Pulmonary adenomatosis
Cysticercosis (<i>C. cellulosae</i>)	Rabies
Dourine	Rift Valley fever
Duck virus enteritis	Rinderpest
Duck virus hepatitis	Scrapie
East coast fever	Screw worm fly
Eastern equine encephalomyelitis	Sheep pox
Elaphostrongylosis	Sheep scab
Epizootic lymphangitis	Spongiform encephalopathies
Encephalitides (tick -borne)	Surra

SCHEDULE 3 [continued - Exotic Diseases]

Equine babesiosis	Swine influenza
Equine encephalosis	Swine vesicular disease
Equine influenza	Teschen disease
<i>Fasciola gigantica</i>	Transmissible gastroenteritis
Foot and mouth disease	Trichinellosis
Fowl typhoid (<i>S. gallinarum</i>)	Venezuelan equine encephalomyelitis
Getah virus	Vesicular exanthema
Goat pox	Vesicular stomatitis
Glanders	Warble fly infestation
Haemorrhagic septicaemia	Wesselsbron disease
Heartwater	Western equine encephalomyelitis
Hendra virus	

Part B Exotic Diseases of Bees

Africanised bees	Tropilaelaps mite (<i>Tropilaelaps clarae</i>)
Tracheal mite (<i>Acarapis woodi</i>)	Varroa mite (<i>Varroa destructor</i>)
	Varroa mite (<i>Varroa jacobsoni</i>)

Part C Exotic Disease of Fish**Exotic Diseases of Fin Fish**

Bacterial kidney disease (<i>Renibacterium salmoninarum</i>)
Channel catfish virus disease
Enteric Redmouth disease (<i>Yersinia ruckeri</i> – Hagerman strain)
Enteric septicaemia of catfish (<i>Edwardsiella ictaluri</i>)
Epizootic ulcerative syndrome (<i>Aphanomyces invaderis</i>)
Furunculosis (<i>Aeromonas salmonicida</i> subsp. <i>salmonicida</i>)
Gyrodactylosis (<i>Gyrodactylus salaris</i>)
Infectious haematopoietic necrosis
Infectious pancreatic necrosis
Infectious salmon anaemia
<i>Oncorhynchus masou</i> virus disease
Piscirickettsiosis (<i>Piscirickettsia salmonis</i>)
Red sea bream iridoviral disease
Spring viraemia of carp
Viral encephalopathy and retinopathy
Viral haemorrhagic septicaemia
Whirling disease (<i>Myxobolus cerebralis</i>)
White sturgeon iridoviral disease

Exotic Diseases of Molluscs

Akoya Oyster disease
Bonamiosis (<i>Bonamia ostreae</i> , <i>Bonamia exitiosus</i> , <i>Mikrocytos roughleyi</i>)
SSO Disease (<i>Haplosporidium costale</i>)
Marteiliosis (<i>Marteilia refringens</i> , <i>Marteilia sydneyi</i>)

SCHEDULE 3 [continued - Exotic Diseases]

Mikrocytosis (*Mikrocytos mackini*)
MSX Disease (*Haplosporidium nelsoni*)
Perkinsosis (*Perkinsus marinus*, *Perkinsus olseni/atlanticus*)
Iridoviroses
Withering syndrome of abalones (*Candidatus Xenohaliotis californiensis*)
Exotic Diseases of Crustacea
Baculoviral midgut gland necrosis
Crayfish plague (*Aphanomyces astaci*)
Gill-associated virus
Infectious hypodermal and haematopoietic necrosis
Necrotising hepatopancreatitis
Tetrahedral baculovirosis (*Baculovirus penaei*)
Spherical baculovirosis (*Penaeus monodon*-type baculovirus)
Spawner-isolated mortality virus disease
Taura syndrome
White spot disease
Yellowhead disease

This Order comes into operation on the day it is published in the Government Gazette.

Dated 20 May 2003

Responsible Minister

BOB CAMERON

Minister for Agriculture

HELEN DOYE
Clerk of the Executive Council

Borrowing and Investment Powers Act 1987

APPROVAL BY THE GOVERNOR IN COUNCIL OF INVESTMENT POWERS FOR
GOULBURN VALLEY WATER AUTHORITY

Order in Council

The Governor in Council, pursuant to Section 17A of the **Borrowing and Investment Powers Act 1987**, (“the Act”) hereby declares that sections 5, 8, 11, 11AA, 12, 14, 20, 20A and 21 of the Act apply to Goulburn Valley Water Authority, an “Authority” within the meaning of the **Water Act 1989**, with effect from and including 13 May 2003.

Dated 20 May 2003

Responsible Minister:

JOHN BRUMBY MP

Treasurer

HELEN DOYE
Clerk of the Executive Council

Catchment and Land Protection Act 1994

DECLARATION OF CERTAIN PLANTS TO BE STATE PROHIBITED WEEDS

On the recommendation of the Minister for Environment, the Governor in Council under section 58(1) of the **Catchment and Land Protection Act 1994** declares the plants listed in the Schedule below to be State prohibited weeds.

The Order applies to the whole of Victoria.
Dated 20 May 2003
Responsible Minister:
JOHN THWAITES
Minister for Environment

HELEN DOYE
Clerk of the Executive Council

Schedule

Acacia karroo Hayne – Karoo thorn.
Acacia erioloba E. Mey. – Giraffe thorn.
All species of *Equisetum*.
Fallopia japonica (Houtt.) Ronse Decr. – Japanese knotweed.
Fallopia sachalinensis (F. Schmidt) Ronse Decr. – Giant knotweed.
Fallopia x bohémica – (a cross between *Fallopia sachalinensis* and *Fallopia japonica*).
All species of *Hieracium*.
Nassella charruana (ARechave.) Barkworth – Lobed needle grass.
Nassella tenuissima (Trin.) Barkworth – Mexican feather grass.
Orobancha ramosa L. – Branched broomrape.

Plant Health and Plant Products Act 1995 DECLARATION OF AN EXOTIC PLANT DISEASE

The Governor in Council under section 5 of the **Plant Health and Plant Products Act 1995** declares potato tuber necrotic ring spot disease caused by Potato virus Y^{NTN} to be an exotic disease for the purposes of section 3 of the Act.
Dated 20 May 2003
BOB CAMERON MP
Minister for Agriculture

HELEN DOYE
Clerk of the Executive Council

Crown Land (Reserves) Act 1978 NOTICE OF INTENTION TO REVOKE TEMPORARY RESERVATIONS

The Governor in Council under section 10 of the **Crown Land (Reserves) Act 1978** gives notice of intention to revoke the following temporary reservations:

KOO-WEE-RUP EAST — The temporary reservation by Order in Council of 30 April, 1957 of an area of 7841 square metres, more or less, of land in the Parish of Koo-wee-rup East as a site for a Municipal Depot. — (Rs 7564).

SAN REMO — The temporary reservation by Order in Council of 22 April, 1969 of an area of 3.845 hectares of land in the Township of San Remo, Parish of Woolamai as a site for Public Recreation, so far only as the portion containing 2932 square metres being Crown Allotment 2002, Township of San Remo as indicated by hatching on plan hereunder. (GP1179) — (Rs 9152).

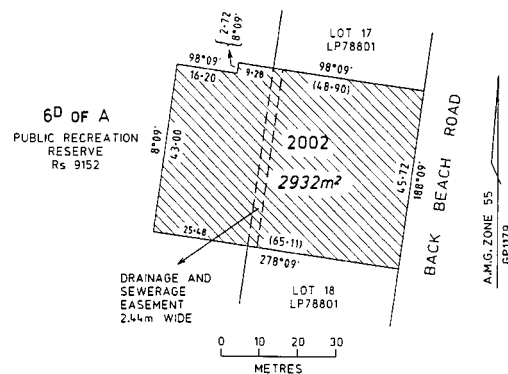

SCORESBY — The temporary reservation by Order in Council of 4 December, 2001 of an area of 747.3 hectares, more or less, of land in the Parishes of Nunawading, Scoresby, Mulgrave and Narree Worran as a site for conservation, recreation, leisure and tourism purposes, so far only as the portions containing a total of 9127 square metres shown as Crown Allotments 2017, 2018, 2019 and 2020, Parish of Scoresby on Plan No. LEGL./03-002 lodged in the Central Plan Office. — (LA/24/0011).

This Order is effective from the date on which it is published in the Government Gazette.

Dated 20 May 2003
Responsible Minister
MARY DELAHUNTY
Minister for Planning

HELEN DOYE
Clerk of the Executive Council

Crown Land (Reserves) Act 1978
REVOCATION OF TEMPORARY
RESERVATIONS

The Governor in Council under section 10 of the **Crown Land (Reserves) Act 1978** revokes the following temporary reservations:

MELBOURNE — The temporary reservation by Order in Council of 10 November, 1959 of an area of 1518 square metres of land in Section 19E, City of Melbourne, Parish of Melbourne North as a site for Public Buildings. — (Rs 7880).

MELBOURNE — The temporary reservation by Order in Council of 8 May, 1979 of an area of 3951 square metres of land being Crown Allotment 2, Section 19E, City of Melbourne, Parish of Melbourne North as a site for Recreation purposes. — (Rs 10842).

TRUGANINA — The temporary reservation by Order in Council of 12 June, 1991 of an area of 12.13 hectares of land being Crown Allotment 6, Section 19, Parish of Truganina as a site for preservation of native grasslands, so far only as the portion containing 3.77 hectares shown as Crown Allotment 2004, Parish of Truganina on Original Plan No. 121882 lodged in the Central Plan Office. — (Rs 12053).

This Order is effective from the date on which it is published in the Government Gazette.

Dated 20 May 2003

Responsible Minister
 MARY DELAHUNTY
 Minister for Planning

HELEN DOYE
 Clerk of the Executive Council

Crown Land (Reserves) Act 1978
TEMPORARY RESERVATION OF
CROWN LANDS

The Governor in Council under section 4(1) of the **Crown Land (Reserves) Act 1978** temporarily reserves the following Crown lands which in his opinion are required for the purposes mentioned:—

MUNICIPAL DISTRICT OF THE
GREATER BENDIGO CITY COUNCIL

HUNTLY — Conservation of an area of natural interest, combined area 7183 square metres,

being Crown Allotments 2001 and 2002, Township of Huntly, Parish of Huntly as indicated by hatching on plan hereunder. (GP1132) — (06/P129765).

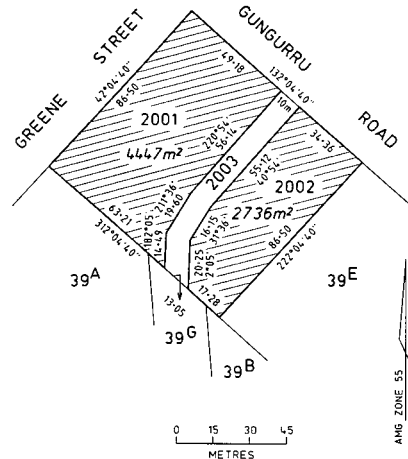

Total area of hatched portions 7183m²

MUNICIPAL DISTRICT OF THE
GREATER BENDIGO CITY COUNCIL

HUNTLY - Water supply purposes, 908 square metres, being Crown Allotment 2003, Township of Huntly, Parish of Huntly as indicated by hatching on plan hereunder. (GP1132-A) — (06/P129765).

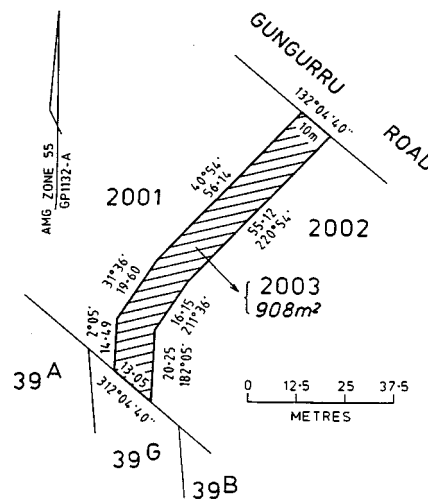

MUNICIPAL DISTRICT OF THE
CARDINIA SHIRE COUNCIL

KOO-WEE-RUP EAST — Public purposes, 14.95 hectares being Crown Allotment 2001, Parish of Koo-wee-rup East as shown on Original Plan No. 121955 lodged in the Central Plan Office. — (1202679).

MUNICIPAL DISTRICT OF THE
GOLDEN PLAINS SHIRE COUNCIL

SMYTHESDALE — Public Recreation, 15 hectares, more or less, being Crown Allotments 2001 and 2002, Parish of Smythesdale as indicated by hatching on plan hereunder. (GP1146) — (Rs 2034).

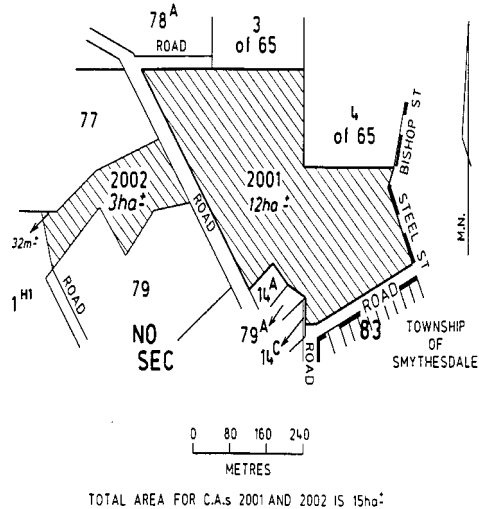

This Order is effective from the date on which it is published in the Government Gazette.

Dated 20 May 2003

Responsible Minister
MARY DELAHUNTY
Minister for Planning

HELEN DOYE
Clerk of the Executive Council

Land Act 1958

CLOSURE OF UNUSED ROADS

The Governor in Council under section 349 of the **Land Act 1958** and with the concurrence in writing of the municipalities in which the roads are situated and the owners of land adjoining those roads closes the following unused roads:

MUNICIPAL DISTRICT OF THE
CITY OF PORT PHILLIP

PORT MELBOURNE — The road in the City of Port Melbourne, Parish of Melbourne South shown as Crown Allotment 2010 on Original Plan No. 121962 lodged in the Central Plan Office. — (12/L12-1148).

MUNICIPAL DISTRICT OF THE
WODONGA RURAL CITY COUNCIL

WODONGA — The roads in the Township of Wodonga, Parish of Wodonga being Crown Allotments 2011 and 2012 as indicated by hatching on plan hereunder. (GP1123) — (L8-6567).

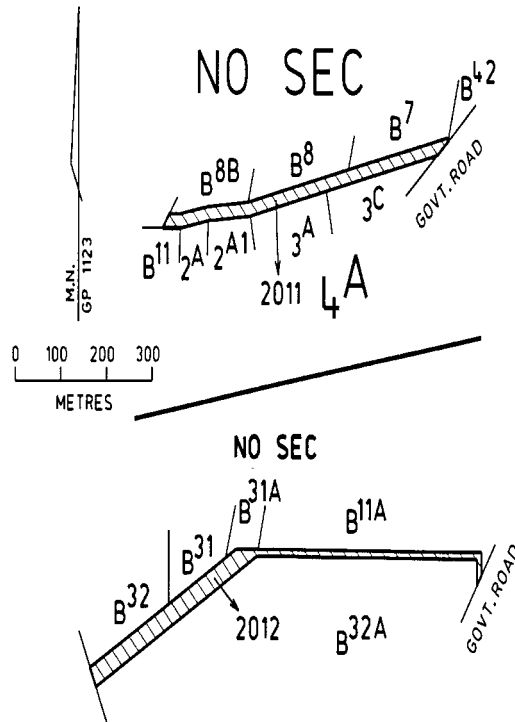

This Order is effective from the date on which it is published in the Government Gazette.

Dated 20 May 2003

Responsible Minister
MARY DELAHUNTY
Minister for Planning

HELEN DOYE
Clerk of the Executive Council

Crown Land (Reserves) Act 1978

**DISSOLUTION OF INCORPORATED
COMMITTEE OF MANAGEMENT**

Smythesdale Cricket and
General Recreation Reserve

The Governor in Council under section 14A(7) of the **Crown Land (Reserves) Act 1978** dissolves the "Smythesdale Equestrian Reserve Committee of Management Incorporated"

constituted by Order in Council of 6 June 2000
(vide Government Gazette of 8 June, 2000 –
page 1214). — Rs 2034.

This Order is effective from the date on
which it is published in the Government
Gazette.

Dated 20 May 2003

Responsible Minister
MARY DELAHUNTY
Minister for Planning

HELEN DOYE
Clerk of the Executive Council

This page left blank intentionally

**SUBORDINATE LEGISLATION ACT 1994
NOTICE OF MAKING OF STATUTORY
RULES**

Notice is hereby given under Section 17 (2) of the **Subordinate Legislation Act 1994** of the making of the following Statutory Rules:

37. *Statutory Rule:* Livestock Disease Control (Amendment) Regulations 2003
Authorising Act: Livestock Disease Control Act 1994
Date of making: 20 May 2003
38. *Statutory Rule:* Fisheries (Compensation and Procedures) Regulations 2003
Authorising Act: Fisheries Act 1995
Date of making: 20 May 2003
39. *Statutory Rule:* Domestic (Feral and Nuisance) Animals (Amendment) Regulations 2003
Authorising Act: Domestic (Feral and Nuisance) Animals Act 1994
Date of making: 20 May 2003
40. *Statutory Rule:* Subordinate Legislation (Architects Regulations 1993 – Extension of Operation) Regulations 2003
Authorising Act: Subordinate Legislation Act 1994
Date of making: 20 May 2003
41. *Statutory Rule:* Surveyors (Registration) Regulations 2003
Authorising Act: Surveyors Act 1978
Date of making: 21 May 2003

**PRICING FOR SPECIAL GAZETTE,
PERIODICAL GAZETTE AND VICTORIAN
LEGISLATION**

Retail price varies according to the number of pages in each Victoria Government Special Gazette, Victoria Government Periodical Gazette and Victorian legislation. The table below sets out the prices that apply.

<i>Price Code</i>	<i>No. of Pages (Including cover and blank pages)</i>	<i>Price*</i>
A	1–16	\$3.65
B	17–32	\$5.40
C	33–48	\$7.40
D	49–96	\$11.50
E	97–144	\$14.85
F	145–192	\$17.55
G	193–240	\$20.25
H	241–288	\$21.55
I	289–352	\$24.25
J	353–416	\$28.35
K	417–480	\$32.35
L	481–544	\$37.75
M	545–608	\$43.15
N	609–672	\$48.55
O	673–736	\$53.90
P	737–800	\$59.30

**All Prices Include GST*

ADVERTISERS PLEASE NOTE

As from 22 May 2003

The last Special Gazette was No. 94 dated 21 May 2003

The last Periodical Gazette was No. 1 dated 4 June 2002

CONTENTS

	Page
Estates of Deceased Persons	1157
Government and Outer Budget Sector	
Agencies Notices	1179
Orders in Council	1218
Acts — Borrowing and Investment Powers; Catchment and Land Protection; Crown Land (Reserves); Land; Livestock Disease Control; Plant Health and Plant Products	
Private Advertisements	1157
Proclamations	1178

The Victoria Government Gazette is published by The Craftsman Press Pty. Ltd. with the authority of the Government Printer for the State of Victoria
© State of Victoria 2003

ISSN 0819-5471

This publication is copyright. No parts may be reproduced by any process except in accordance with the provisions of the Copyright Act.

Products and services advertised in this publication are not endorsed by The Craftsman Press Pty. Ltd. or the State of Victoria and neither of them accepts any responsibility for the content or the quality of reproduction. The Craftsman Press Pty. Ltd. reserves the right to reject any advertising material it considers unsuitable for government publication.

Address all enquiries to the
Government Printer for the State of Victoria
Level 2 1 Macarthur Street
Melbourne 3002
Victoria Australia

RETAIL SALES

Information Victoria Bookshop
356 Collins Street Melbourne 3000.
Telephone enquiries 1300 366 356

City Graphics
Level 1, 520 Bourke Street
Melbourne 3000
Telephone enquiries (03) 9600 0977

Recommended Retail Price \$1.95 (includes GST)

Government and Outer Budget Sector Agencies please note:
STYLE REQUIREMENTS.

To ensure that material received can be reproduced, and that errors are minimised, the following guidelines are to be observed when submitting material by fax.

Fax resolution:

Material sent by fax should be transmitted using Fine Resolution (200 dots per inch by 200 dpi).

Font size:

Use 12 point (10 pitch) or larger.

Font Style:

Clear plain font styles, such as Helvetica, should be used.

Graphics:

Line drawings should be transmitted as large as possible to ensure clarity. Drawings up to A4 size sent by fax using Fine Resolution provide a good quality for reproduction.

Avoid:

Italics, underlining and full justification.

Ensure document is square when sending as documents that are sent skewed are difficult to read and process.

ISSN 0819-5471



9 770819 549762