



Victoria Government Gazette

No. G 26 Thursday 26 June 2003

GENERAL

GENERAL AND PERIODICAL GAZETTE

Copy to: Gazette Officer
The Craftsman Press Pty. Ltd.
125 Highbury Road,
Burwood Vic 3125
Telephone: (03) 9926 1233
Facsimile: (03) 9926 1292
DX: 32510 Burwood
Email: gazette@craftpress.com.au

Advertising Rates and Payment

All prices include GST

Private Notices

Payment must be received in advance with advertisement details.

33 cents per word – Full page \$198.00.

Additional costs must be included in prepayment if a copy of the gazette is required. Copy Prices – Page

\$1.65 – Gazette \$3.52 – Certified copy of Gazette \$3.85 (all prices include postage). *Cheques should be made payable to The Craftsman Press Pty. Ltd.*

Government and Outer Budget Sector Agencies Notices

Not required to prepay.

Advertisements may be faxed or sent via email with a cover sheet, marked to the attention of the Gazette Officer.

Floppy Disks (Mac & PC) can also be accepted.

Costs can be calculated on the following basis:

Per Line	Typeset
Single column	\$1.71
Double column	\$3.41
Full Page	\$71.28

The Craftsman Press is pleased to offer a series of discounts from the typesetting costs.

1. Copy supplied on disk.
2. Copy supplied via email.
3. Artwork for forms and other material which require exact reproduction.

1. Copy supplied on disk.

Where a disk is supplied and there is minimum alteration required, **30% off.**

Where a disk is supplied requiring extraneous matter stripped out and styles applied, **20% off.**

2. Copy supplied via email.

Where a notice is sent via email and there is minimum alteration required, **25% off.**

Where email is supplied requiring extraneous matter stripped out and styles applied, **15% off.**

3. Artwork for forms and other material which requires exact reproduction.

Scanning and sizing of artwork for forms, to be reproduced in page format, **35% off.**

Copy Deadline for General Gazette

9.30 a.m. Monday – (Private Notices)

9.30 a.m. Tuesday – (Government and Outer Budget Sector Agencies Notices)

Advertisers should note:

- Late copy received at The Craftsman Press Pty. Ltd. after deadlines will be placed in the following issue of VGG, irrespective of any date/s mentioned in the copy (unless otherwise advised).
- Late withdrawal of advertisements (after client approval, before printing) will incur 50 per cent of the full advertising rate to cover typesetting, layout and proofreading costs.
- Proofs will be supplied only when requested or at the direction of the Gazette Officer.
- No additions or amendments to material for publications will be accepted by telephone.
- Orders in Council may be lodged prior to receiving assent with the Governor's or Clerk's signature. They will only be published once approved and signed.
- Accounts over 90 days will be issued with a letter of demand.
- Government and Outer Budget Sector Agencies please note: *See style requirements on back page.*

SPECIAL GAZETTES

Copy to: Gazette Officer
The Craftsman Press Pty. Ltd.
125 Highbury Road
Burwood Vic 3125
Telephone: (03) 9926 1233
Facsimile: (03) 9926 1292
Email: gazette@craftpress.com.au

Advertising Rates and Payment

Private Notices

Full Page \$396.00

Payment must be received in advance with notice details.

Government and Outer Budget Sector Agencies Notices

Full Page
Typeset
\$106.92

Note:

The after hours numbers for Special Gazettes are:

Telephone: **0419 327 321**
0419 325 882
0417 391 171

SUBSCRIPTIONS AND RETAIL SALES

Copies of the *Victoria Government Gazette* can be purchased from The Craftsman Press Pty. Ltd. by subscription.

The *Victoria Government Gazette*

General and Special – \$198.00 each year

General, Special and Periodical – \$264.00 each year

Periodical – \$132.00 each year

Subscriptions are payable in advance and accepted for a period of one year. All subscriptions are on a firm basis and refunds will not be given.

All payments should be made payable to The Craftsman Press Pty. Ltd.

Subscription enquiries:

The Craftsman Press Pty. Ltd.
125 Highbury Road, Burwood Vic 3125

INDEX TO PRIVATE ADVERTISERS

B

Borchard & Moore1481

C

Celina Roth1481

D

David Stagg Tonkin & Company1482

E

Engel & Partners Pty1482

J

John Matthies & Co1482

John Stewart1482

L

Littleton Hackford1482

Lucas Neale1482

M

McKean & Park1482

Maddocks1483

Mahons with Yuncken Yuncken1483

Mills Oakley1483

P

Paul McGuinness & Associates1483

R

Raboy & Associates1483

Rennick & Gaynor1484

Rigby Cooke1484

S

Sewells Larkins McCarthy1484

W

W. J. Gilbert1484

Wills & Probate Victoria1484

PRIVATE ADVERTISEMENTS



FULBRIGHT PROFESSIONAL AWARDS

For Study and /or Research in the USA

(3 - 6 months in 2004 / 2005)

Valued at between A\$20,000 and \$30,000

The Fulbright Professional Award is aimed at junior to middle level staff poised for advancement to a senior role, to undertake a 3 – 6 month program of professional development in the United States. The proposal must include an educational component (such as a short-course and/or research) and may involve other forms of professional experience including visits to relevant organisations.

Selection is based on the applicants professional achievement and a proposal that indicates how the proposed visit will further their professional development, contribute to fostering improved understanding between the peoples of the two countries and the potential benefits that will flow to the applicant's employer and /or industry.

For further information and applications see www.fulbright.com.au or call 02 6260 4460.
Applications close 31 August 2003.

DISSOLUTION OF PARTNERSHIP

Notice Pursuant to the **Partnership Act 1958**

Take notice that the partnership of Leonie Ruth Brasier and Peter Hartley Love, trading as Hartleys Lawyers from 461B Ballarat Road, Sunshine, will be dissolved as at 30 June 2003.

DISSOLUTION OF PARTNERSHIP

Take notice that the partnership between James William John Hart and Steve Peter Neville who carried on business under the registered business name "Suborn" at Factory 5, 112 Hammond Road, Dandenong 3175, has been dissolved as from 6 February 2003.

Dated 27 May 2003

BALLARDS, solicitors,
4/426 Burwood Highway, Wantirna South 3152.

Re: KEVIN RAYMOND LUCAS, late of 88 Dunblane Road, Noble Park, Victoria, retired machinist, deceased. Creditors, next-of-kin and others having claims in respect of the estate of the deceased, who died on 14 February 2003, are required by the trustee, Blanche Lillian

Lucas of 88 Dunblane Road, Noble Park, Victoria, home duties, the sister, to send particulars to the trustee by 9 September 2003 after which date the trustee may convey or distribute the assets, having regard only to the claims of which the trustee has notice.

BORCHARD & MOORE, solicitors,
44 Douglas Street, Noble Park 3174.

Re: Estate of KATHRYN LOUISE ABRAHAMS.

Creditors, next-of-kin and others having claims in respect of the estate of KATHRYN LOUISE ABRAHAMS, late of 32 Laburnum Street, Brighton, in the State of Victoria, the deceased, who died on 5 February 2003, are required by Ian Roth, the executor named in the Will of the said Kathryn Louise Abrahams, to send particulars thereof to the undermentioned solicitors by 24 August 2003 after which date he will distribute the assets having regard only to the claims of which notice has been received.

CELINA ROTH, solicitor,
146 Church Street, Brighton 3186.

IAN CAMPTON HAMILTON, late of 55 Silver Street, Eltham, research scientist, deceased. Creditors, next-of-kin and others having claims in respect of the estate of the abovenamed deceased, who died on 13 July 2002, are required by Equity Trustees Limited of Level 5, 575 Bourke Street, Melbourne, the legal personal representative of the deceased, to send particulars of their claims to the said company at GPO Box 2307, Melbourne 3001, no later than 24 August 2003 after which date they will convey or distribute the assets having regard only to the claims of which they then have notice.

DAVID STAGG TONKIN & COMPANY,
legal practitioners,
8-10 Flintoff Street, Greensborough 3088.

Creditors, next-of-kin and others who have claims in respect of the estate of JIM IAN HENDERSON, late of Mottle Range Road, Wairewa, in the State of Victoria, farmer, deceased, who died on 17 March 2002, are to send particulars of their claims to the administrators care of Engel & Partners Pty of 109 Main Street, Bairnsdale by 30 August 2003 after which date it will distribute the assets having regard only to the claims of which it then has notice.

ENGEL & PARTNERS PTY,
legal practitioners,
109 Main Street, Bairnsdale.

Re: BARBARA HELEN GARDINER.

Creditors, next-of-kin and others having claims in respect of the estate of BARBARA HELEN GARDINER, formerly of Flat 15, 24 Springfield Avenue, Toorak but late of Camberlea Private Nursing Home, 629 Riversdale Road, Camberwell, Victoria, home duties, deceased, who died on 25 January 2003, are required by the executor of the estate, Trust Company of Australia Limited, ACN 004 027 749 of 151 Rathdowne Street, Carlton South, Victoria 3053, to send particulars of their claims to the executor at its address of 151 Rathdowne Street, Carlton South, Victoria 3053 by 29 August 2003 after which date the executor may convey or distribute the assets having regard only to the claims of which it then has notice.

JOHN MATTHIES & CO.,
legal practitioners for the applicant,
6th Floor, 416 Collins Street, Melbourne 3000.

Creditors, next-of-kin and others having claims in respect of the Will of VINCENZA MARINO, late of 110 Edinburgh Street, Flemington, Victoria, widow, deceased, who died on 22 May 2003, are requested to send particulars of their claims to the executor, Giuseppe Marino, care of the undermentioned legal practitioner by 27 August 2003 after which date he will distribute the assets having regard only as to the claims of which he then has notice.

JOHN STEWART, legal practitioner,
290 Racecourse Road, Newmarket.

Creditors, next-of-kin and others having claims in respect of the estate of MARY LORETTA HOGGARD, late of 5 Foxlease Avenue, Traralgon, Victoria, home duties, deceased, who died on 2 June 2003, are to send their claims to the trustee, Robert Joseph Hoggard of 10 Michael Court, Traralgon, Victoria, care of the below mentioned solicitors by 27 August 2003 after which date he will distribute the assets of the deceased having regard only to the claims of which he then has notice.

LITTLETON HACKFORD, solicitors,
Law Chambers,
115 Hotham Street, Traralgon, Vic. 3844.

In the Will of MARGARET CLAVER MCGOWAN, late of Goonawarra Nursing Home, Sunbury, Victoria, widow, deceased. Creditors, next-of-kin and others having claims in respect of the estate of the abovenamed deceased, who died on 28 January 2003, are required by the executor, David Lucas of 26 Station Street, Ferntree Gully, Victoria, solicitor, to send particulars of their claims to him care of the undermentioned solicitors, Lucas Neale, by 26 August 2003 after which date he will distribute the assets having regard only to the claims of which he then has notice.

LUCAS NEALE, solicitors,
26 Station Street, Ferntree Gully 3156.

Re: FRANCIS FERI GOODMAN, deceased.

Creditors, next-of-kin or others having claims in respect of the estate of FRANCIS FERI GOODMAN, also known as Francis Goodman, Frank Feri Goodman and Frank Goodman, deceased, who died on 8 March 2003, are to send particulars of their claims to

the executor, Andrew Mark Pinder, care of the undermentioned solicitors by 26 August 2003 after which date the executor will distribute the assets having regard only to the claims of which the executor then has notice.

McKEAN & PARK, lawyers & consultants,
405 Little Bourke Street, Melbourne 3000.

Re: MAGDA HORVAT, late of Unit 6, 316 Wattletree Road, East Malvern, Victoria, ophthalmologist, deceased. Creditors, next-of-kin and others having claims in respect of the estate of the deceased, who died on 9 September 2002, are required by the trustees, Perpetual Trustees Consolidated Limited, ACN 004 029 841, in the Will called National Mutual Trustees Limited of 360 Collins Street, Melbourne, Victoria and Judy Will of 2 Marlborough Avenue, Camberwell, Victoria, to send particulars to the trustees by 26 August 2003 after which date the trustees may convey or distribute the assets, having regard only to the claims of which the trustees have notice.

MADDOCKS, lawyers,
140 William Street, Melbourne 3000.

Re: TERRENCE JAMES PARKE, late of 16 Cameron Court, Toolern Downs, Victoria, self employed managing director, deceased. Creditors, next-of-kin and others having claims in respect of the estate of the deceased, who died on 15 April 2002, are required by the trustee, Marlene Joyce Parke of 17 Darcy Street, Bacchus Marsh, Victoria, widow, to send particulars to the trustee by 26 August 2003 after which date the trustee may convey or distribute the assets, having regard only to the claims of which the trustee has notice.

MADDOCKS, lawyers,
140 William Street, Melbourne 3000.

Re: URSULA MARY HARGREAVES, late of Blackburn Nursing Home, 28 The Avenue, Blackburn, Victoria, but formerly of Room 43, Balwyn Manor, 23 Maleela Avenue, Balwyn, Victoria, widow, deceased. Creditors, next-of-kin and others having claims in respect of the estate of the deceased, who died on 19 April 2003, are required by the trustee, Noela Dorothy Hollins, no relation, to send particulars to the trustee

c/- Mahons with Yuncken & Yuncken by 25 August 2003 after which date the trustee may convey or distribute the assets, having regard only to the claims of which the trustee has notice.

MAHONS with YUNCKEN & YUNCKEN,
solicitors,
178 Whitehorse Road, Blackburn 3130.

ANTHONY DAVID WALSH, late of 11 Dougherty Court, Mulgrave, Victoria, bank manager, deceased. Creditors, next-of-kin and others having claims in respect of the estate of the deceased, who died on 26 May 2003, are required by the substituted executor, ANZ Executors & Trustee Company Limited (ACN 006 132 332) of Level 21, 530 Collins Street, Melbourne, to send particulars to it by 26 August 2003 after which date it may convey or distribute the assets having regard only to the claims of which it then has notice.

MILLS OAKLEY, lawyers,
4th Floor, 121 William Street, Melbourne.

LYNNE MAREE JOWETT, late of 9/48 Esplanade West, Port Melbourne, Victoria, secretary, deceased. Creditors, next-of-kin and others having claims in respect of the estate of the deceased, who died on 15 December 2002, are required to send particulars of their claims to the trustee, Brian Harvey Jowett, care of the undermentioned solicitors by 31 August 2003 after which date the trustee or personal representative or applicant for grant of administration may convey or distribute the assets, having regard only to the claims of which he then has notice.

PAUL McGUINNESS & ASSOCIATES PTY,
solicitors,
3 Eighth Avenue, Rosebud 3939.
Telephone: (03) 5986 6999.

Re: ANNA MARIA (also known as Annemarie) Mankiewicz, late of Unit 1, 225 Orrong Road, Balaclava, in the State of Victoria, widow, deceased. Creditors, next-of-kin and others having claims in respect of the estate of the deceased, who died on 7 March 2003, are required by the executors under the Grant of Probate, Stephan Ross, in the Will called Stephan Rosshandler of 23 Palmer Avenue,

Balwyn, in the said State and Geoffrey Sandler of 30 Central Park Road, East Malvern, in the said State, to send particulars to them by 27 August 2003 after which date the executors may convey or distribute the assets, having regard only to the claims of which they then have notice.

Dated 20 June 2003

RABOY & ASSOCIATES, lawyers,
414 Lonsdale Street, Melbourne.

DAVID RAYMOND TONKIN, late of Wirrim Lodge Nursing Home, Taverner Street, Birchip, Victoria, retired gentleman, deceased. Creditors, next-of-kin and others having claims in respect of the estate of the deceased, who died on 19 March 2003, are required by the executrix, Dianne Lorraine Swann of 691 Siris Road, Jarvis Creek, Victoria, to send particulars to her, care of the undersigned by 26 August 2003, after which date the executrix may convey or distribute the assets having regard only to the claims of which she then has notice.

RENNICK & GAYNOR, solicitors,
431 Riversdale Road, Hawthorn East.

NORMA MARGARET MALCOLM, late of Bowen Old Peoples Home, Wests Lane, Bowen, Queensland, home duties, deceased. Creditors, next-of-kin and others having claims in respect of the estate of the deceased, who died on 4 September 2002, are required by the executor, David Anthony Corrigan of 431 Riversdale Road, Hawthorn East, Victoria, to send particulars to him care of the undersigned by 26 August 2003 after which date the executor may convey or distribute the assets having regard only to the claims of which he then has notice.

RENNICK & GAYNOR, solicitors,
431 Riversdale Road, Hawthorn East.

Creditors, next-of-kin or others having claims in respect of the estate of PATRICIA WINIFRED McSPEERIN, late of 7 Banff Close, Mulgrave, Victoria, home duties, deceased, who died on 15 March 2003, are to send particulars of their claims to the executor care of the undermentioned solicitors by 28 August 2003 after which date the executor will distribute the assets having regard only to the claims of which the executor then has notice.

RIGBY COOKE, solicitors,
469 La Trobe Street, Melbourne 3000.

Re: STEPHEN DENNIS RYAN, late of 1/61 Gravesend Street, Colac, plant supervisor, deceased. Creditors, next-of-kin and others having claims in respect of the estate of the deceased, who died on 22 May 2003, are required by the deceased's personal representatives, Amanda Jayne Finn, Joseph Daniel Ryan and Barbara Ann Ryan to send particulars to them care of the undermentioned solicitors by 25 August 2003 after which date the personal representatives may convey or distribute the assets having regard only to the claims of which they then have notice.

SEWELLS LARKINS McCARTHY, lawyers,
119 Murray Street, Colac.

GYP GASKIN, late of Flat 1, 2A Parkside Street, Elsternwick, Victoria, retired, deceased. Creditors, next-of-kin and others having claims in respect of the estate of the deceased, who died on 31 October 2002, are required by the executor, Brian Royer Soward Comport of Suite 1, 614 Hawthorn Road, Brighton East, Victoria, accountant, to send particulars of their claims to the executor care of the undersigned solicitors by 1 October 2003 after which date the executor will convey or distribute the assets, having regard only to the claims of which he then has notice.

W. J. GILBERT & CO., lawyers,
221 Glen Huntly Road, Elsternwick.

HENRY STEPHEN THOMPSON, late of 44 Millewa Avenue, Malvern East, Victoria, retired, deceased. Creditors, next-of-kin and others having claims in respect of the estate of the deceased, who died on 21 April 2003, are required by the executors, Murray Sinderberry of 1 Mill Avenue, Forest Hill, Victoria, retired bank manager and Courtney Richard Dyer of 221 Glen Huntly Road, Elsternwick, Victoria, solicitor, to send particulars of their claims to the executors care of the undersigned solicitors by 1 October 2003 after which date the executors will convey or distribute the assets, having regard only to the claims of which they then have notice.

W. J. GILBERT & CO., lawyers,
221 Glen Huntly Road, Elsternwick.

Re: VERNA SYLVIA REA HAND, late of 28 The Avenue, Blackburn, Victoria. Creditors, next-of-kin and others having claims in respect of the estate of the deceased, who died on

25 March 2003, are required to send particulars of their claims to the executor C/- Permanent Trustee Company Limited, 151 Rathdowne Street, Carlton South, Victoria 3053 by 1 September 2003 after which date the executor may convey or distribute the assets having regard only to the claims of which they may then have notice.

WILLS & PROBATE VICTORIA, lawyers,
Level 5, 360 Little Bourke Street, Melbourne.

Registered Mortgage No. AB630176R and Covenant No. AB630174V affect the said estate and interest.

Terms – Cash/Eftpos
(Debit Cards only/No Credit Cards).
SW-03-001377-1

Dated 26 June 2003

V. PARKIN
Sheriff's Office

In the Supreme Court of the State of Victoria
SALE BY THE SHERIFF

On Wednesday 30 July 2003 at 2.30 p.m. at the Sheriff's Office, 8–20 King Street, Oakleigh. (Unless process be stayed or satisfied).

All the estate and interest (if any) of Michelle Buys of 41 Woods Point Road, Warburton as shown on Certificate of Title as Michelle Gaye Buys, proprietor of an estate in fee simple in the land described on Certificate of Title Volume 8567, Folio 017 upon which is erected a home known as 41 Woods Point Road, Warburton.

Registered Mortgage No. AB566900X affects the said estate and interest.

Terms – Cash/Eftpos
(Debit Cards only – No Credit Cards).
SW-03-002158-1

Dated 26 June 2003

V. PARKIN
Sheriff's Office

In the Supreme Court of the State of Victoria
SALE BY THE SHERIFF

On Wednesday 30 July 2003 at 2.30 p.m. at the Sheriff's Office, 8–20 King Street, Oakleigh. (Unless process be stayed or satisfied).

All the estate and interest (if any) of Kumari Kauye of 23 Nicholson Street, South Yarra, joint proprietor with George Kauye of an estate in fee simple in the land described on Certificate of Title Volume 3397, Folio 217 upon which is erected a house known as 23 Nicholson Street, South Yarra.

Registered Mortgage Nos. W536731P, W536732L, W784687L and Caveat No. W464789Q affect the said estate and interest.

Terms – Cash/Eftpos
(Debit Cards only. No Credit Cards).
SW-02-009872-9

Dated 26 June 2003

V. PARKIN
Sheriff's Office

In the Supreme Court of the State of Victoria
SALE BY THE SHERIFF

On Wednesday 30 July 2003 at 2.30 p.m. at the Sheriff's Office, 8–20 King Street, Oakleigh. (Unless process be stayed or satisfied).

All the estate and interest (if any) of Andrew Dean Tilley of 3 Stockmans Circuit, Pakenham, proprietor of an estate in fee simple in the land described on Certificate of Title Volume 10617, Folio 273 upon which is erected a house known as 3 Stockmans Circuit, Pakenham.

In the Supreme Court of the State of Victoria
SALE BY THE SHERIFF

On Thursday 31 July 2003 at 11.00 a.m. at the Sheriff's Office, Wodonga Court Complex, Wodonga. (Unless process be stayed or satisfied).

All the estate and interest (if any) of Richardson Hotels Pty Ltd of RMB 6180, Yackandandah Road, Wodonga, proprietor of an estate in fee simple in the land consisting of approximately 27.8 hectares being Lots 1, 2 and 4 as described on Certificate of Title Volume 10533, Folio 519 upon which is erected a farm

house and other outbuildings known as corner of Pitt Lane and Wodonga–Yackandandah Road, Staghorn Flat.

Registered Mortgage No. V563248V, Transfer of Mortgage No. X444858G, Variation of Mortgage No. X444859G and Variation of Mortgage No. AB635381N affect the said estate and interest.

The property is located approximately 14 kms north east of Yackandandah. Travel from Yackandandah along Yackandandah Road and the property is located on the east side of the road on the corner of Pitt Lane and Yackandandah Road.

Refer RACV VicRoads Edition 4, Map 35 G6.

Terms – Cash only.

SW-03-002522-2

Dated 26 June 2003

V. PARKIN
Sheriff's Office

Unclaimed Moneys Act 1962

Register of Unclaimed Moneys held by the —

<i>Name of Owner on Books and Last Known Address</i>	<i>Total Amount Due to Owner</i>	<i>Description Of Unclaimed Money</i>	<i>Date when Amount first became Payable</i>
AUSTRALIAN INFRASTRUCTURE FUND LTD			
\$			
Abhill Nominees Pty Ltd, "E. Nicholson Retire Fund A/c", C/- PKF Financial Planning, Floor 11, 485 La Trobe Street, Melbourne	309.10	Cheque	24/08/01
Adanica Pty Ltd, 36 Reid Street, Beaumaris	159.50	"	"
Ms Claire Louise Allen, C/- Andersen Consulting, 141 Walker Street, North Sydney, NSW	104.00	"	07/02/01
Mr Colin Herbert Austin & Mrs Wendy Elizabeth Austin, 32 Dunoon Street, Doncaster	113.91	"	24/08/01
Mrs Margaret Janet Badger, 3 George St, Walkerville, SA	1,032.00	"	07/02/01
Mr Robert Kenneth Baird, 31 Stanton Court, Gisborne	632.50	"	24/08/01
Bedstone Pty Ltd, "Staff Super Fund A/c", 1185 Malvern Road, Malvern	258.00	"	"
Mr James Alwin Blattman, "Christopher Blattman A/c", 6 Haslemere Road, Mitcham	108.00	"	07/02/01
BPC Holdings Pty Ltd, Level 50, 101 Collins Street, Melbourne	3,218.00	"	24/08/01
Breton Pty Ltd, "The Willowtree", 69 Glenisla Drive, Mount Martha	323.00	"	"
Bridell Pty Ltd, "Super Fund A/c", Suite 4, 955 Pacific Highway, Pymble, NSW	360.00	"	07/02/01
Mr Andrew Campbell, 17 Ngatitama Street, Nelson, NZ	808.00	"	"
Casper 1977 Limited, PO Box 465, Warkworth, NZ	720.00	"	"
Casper 1977 Limited, PO Box 465, Warkworth, NZ	328.69	"	24/08/01

Mr Chia-Ling Chang, 2 Grangewood Lane, Christchurch 8005, New Zealand	206.08	''	07/02/01
Mr Francis Christian Charleston, 2 Lister Street, Kew East	200.00	''	''
Mr Donald Lyston Chisholm & Mr John Lyston Chisholm & Mr Raymond Leslie Marriott, C/- Maddock Lonie & Chisholm, Level 7/140 William Street, Melbourne	906.57	''	24/08/01
Clive Et Al Pty Ltd, "Clive Matthews Superfund A/c", 22 Patrick Auld Drive, Auldana, SA	400.00	''	07/02/01
Coreta Pty Ltd, 39/41 Johnston Street, Port Melbourne	160.00	''	''
CS Krishnan Pty Ltd, "Krishnan Super Fund A/c", C/- E., L. & C Baillieu, PO Box 48, Collins Street West	165.00	''	24/08/01
Mr Pasquale Currao, 15 Mariner Road, Illawong, NSW	241.50	''	''
Darren Sheens Holdings Pty Ltd, "Darren Sheens Family A/c", PO Box 6410, Parramatta, NSW	270.60	''	''
Davison Drilling & Irrigation Pty Ltd, "Davison Drilling Super A/c", PO Box 2045, Kent Town, SA	368.00	''	07/02/01
Dellfield Pty Ltd, "Rapid Manor Super Fund A/c", 62 Dellfield Drive, Lower Templestowe	400.00	''	''
Ms Susan Mary Doyle, 60 Middle Head Rd, Mosman, NSW	275.00	''	24/08/01
Mrs Claire Mary Dunn, 66 Stanley Street, Erindale, SA	506.50	''	''
Mrs Diana Mary O'Halloran Evans, "Trading Account", 5 Herbert Street, Medindie, SA	800.00	''	07/02/01
Mr Kevin Charles Field & Mrs Olga Field & Mr Darryl John Shields, "Alltab Super Fund A/c", 5 Sara Grove, Tottenham	400.00	''	07/02/01
Ms Helen Cecil Neill-Fraser, PO Box 411, Sandy Bay, Tas.	246.75	''	24/08/01
Mrs Margaret Helen Grieve, C/- PO Box 924, Traralgon	165.00	''	''
Ms Phillipa Grogan, "Phillipa Super Fund A/c", 37 Mackay Street, Prahran	148.50	''	''
Mrs Pamela Jean Hall & Mr Donald Richard Hall, "The Hall Family A/c", 20 Highfield Avenue, St Georges, SA	123.00	''	''
Mr Gerald Hargrave, "Est of Mary M. Hargrave A/c", PO Box 878, Kent Town, SA	2,160.00	''	07/02/01
Mr John Trevor Hasleby, PO Box 114, Nedlands, WA	162.00	''	24/08/01
Michael Avigdor Hirschfeld & Vivien Elizabeth Hirschfeld Edward Johannes Matla, 112 Cecil Road, Wadestown, Wellington, New Zealand	3,859.39	''	''
Mr Paul Hodgson, "Informed Sources S/Fund A/c", 42 Stonehaven Crescent, Deakin, ACT	162.00	''	''
Mr John Keneth Lloyd Hooton, 16 Upper Minimbah Road, Northbridge, NSW	220.00	''	''
Mr Kelvin Humphries & Ms Jillian Margaret Farmer, "Bensam Superfund A/c", 66 Harrow Road, Somerton Park, SA	167.48	''	''
Mrs Noeline Gloria Jones, 12 Suburban Ave, Ballarat North	120.00	''	07/02/01
Kaawa Tane Pty Limited, "SGS Super Fund A/c", 28 Newport Crescent, Port Macquarie, NSW	129.00	''	24/08/01
Prof David Simon Karpin, 2 St Georges Court, Toorak	1,375.00	''	''
K. F. Pacific Investments Pty Limited, 1/100 Milson Road, Cremorne Point, NSW	800.00	''	07/02/01
K. F. Pacific Investments Pty Limited,			

1/100 Milson Road, Cremorne Point, NSW	550.00	''	24/08/01
Mrs Elizabeth Ruth Lammas, 11/49 Second Avenue, Klemzig, SA	200.00	''	07/02/01
Mrs Jaime Littlewood, Unit 10, 15 Finney Road, Indooroopilly, Qld	253.05	''	24/08/01
Christine Marisa Lokes & Marie Alexa Richardson, "The Karekare A/c", 8 Hanlon Crescent, Devonport, Auckland, New Zealand	384.00	''	07/02/01
Mr Richard Trahair Matthews, 14 Carinya Crescent, Rostrevor, SA	120.00	''	''
Mr George Mavridi & Mr Chris Mavridis, "Kaytana Pty Ltd Super A/c", 79 Ashburn Grove, Ashburton	320.00	''	''
Mr George Mavridi & Mr Chris Mavridis, "Kaytana Pty Ltd Super A/c", 79 Ashburn Grove, Ashburton	220.00	''	24/08/01
Mrs Betty Alison McAuliffe, C/- Mr A. G. Mitchell, 5/14 Hanby Street, Brighton	550.00	''	''
Mr Thomas McCourt McRae, 34 Bally Street, Kelvin Grove, Qld	522.00	''	''
Mr Paul Kevin Moritz, 12 Salisbury Terrace, Collinswood, SA	320.00	''	07/02/01
Mr Radhakrishna Naidu & Ms Sarojini Nair, "R. & S. Naidu Super Fund A/c", 29A Awaba Street, Mosman, NSW	129.00	''	24/08/01
Nybo International Ltd, C/- Wylie McDonald, Level 3, Customs House, Auckland, New Zealand	704.00	''	07/02/01
Mr Barry O'Sullivan & Mrs Margaret O'Sullivan, "O'Sullivan Family Super A/c", 111 Doncaster Road, North Balwyn	176.00	''	24/08/01
Mr Graham Martin Pizzey & Mrs Helen Suzanne Pizzey, "Pizzey Super Fund A/c", PO Box 41, Dunkeld	165.00	''	''
Est Dr John Orde Poynton, C/- Perpetual Portfolio Services, GPO Box 5106, Sydney, NSW	27,874.66	''	''
Mr Paul Arthur Quarrell & Mrs Debora Lynn Quarrell, "Quarrell Superfund A/c", 3 Carden Court, Golden Grove, SA	640.00	''	07/02/01
Mr Paul Arthur Quarrell & Mrs Debora Lynn Quarrell, "Quarrell Superfund A/c", 3 Carden Court, Golden Grove, SA	440.00	''	24/08/01
Ms Caroline Sarah Reed, C/- G. H. MacMorran, PO Box 1574, Paraparaumu Beach, New Zealand	600.00	''	07/02/01
Mr Stephen John Reeves, 64 Memorial Drive, Bar Beach, NSW	224.00	''	''
Mr Stephen John Reeves, 64 Memorial Drive, Bar Beach, NSW	102.92	''	24/08/01
The Rotary Club of Footscray Community Service & House of Friendship Fund Incorporated, PO Box 469, Ascot Vale,	732.00	''	07/02/01
The Rotary Club of Footscray Community Service & House of Friendship Fund Incorporated, PO Box 469, Ascot Vale	295.25	''	24/08/01
Saffron Super Company Pty Ltd, "Yuen Super Fund A/c", Suite 1, 19-23 Hoddle Street, Richmond	110.00	''	''
Scout Association of Australia,			

“Scouting Development A/c”, PO Box 325C, Five Docks, NSW	1,100.00	”	”
Mr Peter David Sidwell, PO Box 181, East Kew	3,547.50	”	24/08/01
Slater Properties Pty Ltd, PO Box 1043, Albury, NSW	252.00	”	”
Mr Max Geoffrey Smith, 12 Aston St, Hunters Hill, NSW	400.00	”	07/02/01
Mrs Margaret Mary Speck, 20A Jellicoe Street, Linden Park, SA	291.50	”	24/08/01
Mrs Theresa Mary Judith Strikis, Parkview, 2 Fir Place, Dernawcourt, SA	193.04	”	07/02/01
Mrs Gabrielle Christine Symons, 114 Rolling Hills Road, Chirnside Park	275.00	”	24/08/01
Mr Simon Gregory Terry, 55 Rose Street, Armadale	160.00	”	07/02/01
Mr Simon Gregory Terry, 55 Rose Street, Armadale	110.00	”	24/08/01
Thinking Nominees Pty Ltd, GPO Box 1392M, Melbourne	800.00	”	07/02/01
Vamece Pty Limited, 21 Duntroon Avenue, Roseville, NSW	162.00	”	24/08/01
Mr Desmond Voss, Lot 83, Kauri Court, Woodford, Qld	168.00	”	”
Mr Murray Withers & Ms Jocelyn Ann Moore, “Abbey A/c”, PO Box 13, 339 Christchurch, New Zealand	257.29	”	”
Mr Chiu Au-Yeung, 71 Eddy Road, Chatswood, NSW	412.50	”	”
Mrs Christine Young & Mr John Young, “Young Super Fund A/c”, Level 10, 461 Bourke Street, Melbourne	180.00	”	07/02/01

03130

CONTACT: ELAINE HARE, PHONE: (03) 9611 5714.

Unclaimed Moneys Act 1962

Register of Unclaimed Moneys held by the —

<i>Name of Owner on Books and Last Known Address</i>	<i>Total Amount Due to Owner</i>	<i>Description Of Unclaimed Money</i>	<i>Date when Amount first became Payable</i>
BRUCE DAVIS FIRST NATIONAL			
	\$		
J. T. Caldwell, 2 Eliza Terrace, Mt Eliza	120.00	Cheque	06/12/01
Val Thompson, 12 Ginnie Court, Mornington	100.00	”	”
Nancy Stevens, 125 Racecourse Road, Mornington	200.00	”	03/05/00
Craig Roberts, 4 Bevnol Road, Langwarrin	500.00	”	23/01/00

03213

CONTACT: LILIAN LEE, PHONE: (03) 5975 4488.

Unclaimed Moneys Act 1962

Register of Unclaimed Moneys held by the —

<i>Name of Owner on Books and Last Known Address</i>	<i>Total Amount Due to Owner</i>	<i>Description Of Unclaimed Money</i>	<i>Date when Amount first became Payable</i>
CASTRAN GILBERT			
	\$		
Ms N. Osman, Flat 2, 19 Hawthorn Road, Caulfield	115.40	Cheque	26/08/98
G. Fiorita & S. Strong, C/- Arthur Murray, 140 Bourke Street, Melbourne	159.50	"	03/09/98
Rescue Plumbing, 10 Colvin Court, Glen Waverley	160.00	"	09/03/00
03038 CONTACT: SUE MURPHY, PHONE: (03) 9827 1177.			

Unclaimed Moneys Act 1962

Register of Unclaimed Moneys held by the —

<i>Name of Owner on Books and Last Known Address</i>	<i>Total Amount Due to Owner</i>	<i>Description Of Unclaimed Money</i>	<i>Date when Amount first became Payable</i>
E. J. LOVE & CO. PTY LTD			
	\$		
Ernesto & Lorinda Andrada, 1/26 Loxton Tce, Epping	380.65	Cheque	15/08/01
03219 CONTACT: MELBA KANDI, PHONE: (03) 9404 4955.			

Unclaimed Moneys Act 1962

Register of Unclaimed Moneys held by the —

<i>Name of Owner on Books and Last Known Address</i>	<i>Total Amount Due to Owner</i>	<i>Description Of Unclaimed Money</i>	<i>Date when Amount first became Payable</i>
FUNTASTIC LIMITED			
	\$		
Australian-American Association Inc. Pty Ltd, 153 Sturt Street, Southbank	640.00	Cheque	27/04/01
Mr Joe Capodicasa, 2/18 Marcia Street, Thomastown	150.00	"	15/10/01
Mrs Lin Chung Chun Feng, 31 McKinley Court, Mt Ommaney, Qld	160.00	"	27/04/01

Mrs Lin Chung Chun Feng, 31 McKinley Court, Mt Ommaney, Qld	120.00	''	15/10/01
Mr David Graham Hendy, "Christian Hendy A/c", 65 Comer Street, East Brighton	150.00	''	''
Mrs Angela Hynds, 53 Tarcoola Drive, Gladstone, Qld	120.00	''	27/04/01
Just Garage Doors & Remotes Pty Ltd, 16 Isobel Street, Clontarf, Qld	115.00	''	''
Mrs Deborah Maree Reid, Paringa, Capella, Qld	160.00	''	''
Mrs Deborah Maree Reid, Paringa, Capella, Qld	120.00	''	15/10/01
Mr Rupert Thyne Reid, 5F/26 Wellington St, Collingwood	400.00	''	27/04/01
Mr Anthony Sallmann & Mrs Ann Sallmann, 7 Ellerslie Place, Toorak	2,000.00	''	''
Dr Anthony John Shakeshaft & Mrs Angela Irene Shakeshaft, "A. & A. Shakeshaft Sf A/c", PO Box 48, Blaxland, NSW	200.00	''	''
Mr Sang Hy Tang, 1 Saunders Street, Clayton South	300.00	''	''
Mr Sang Hy Tang, 1 Saunders Street, Clayton South	225.00	''	15/10/01
West & Smith Holdings Pty Ltd, 68 Horne Street, Campbellfield	120.00	''	27/04/01

03131

CONTACT: ELAINE HARE, PHONE: (03) 9611 5714.

Unclaimed Moneys Act 1962

Register of Unclaimed Moneys held by the —

<i>Name of Owner on Books and Last Known Address</i>	<i>Total Amount Due to Owner</i>	<i>Description Of Unclaimed Money</i>	<i>Date when Amount first became Payable</i>
GRAND HOTEL GROUP			
	\$		
Estate Late Anne Elizabeth Abrahams, C/- Needs Chan & Monahan, PO Box 484, Hurstville BC, NSW	499.98	Cheque	29/08/01
Mr John Robert Bell & Mrs Catherine Bell, "Aust. Drilling Super A/c", PO Box 320, Collins Street West, Melbourne	130.00	''	''
Mr John Robert Bell & Mrs Catherine Bell, "Aust Drilling Super A/c", PO Box 320, Collins Street West, Melbourne	130.00	''	01/03/01
Mr Jonathan Eske & Ms Anne Maree Esk, "Eske Investments S/F A/c", PO Box 5537, West End, Qld	234.00	''	29/08/01
Mrs Lesley Patricia Fulford, PO Box 260, Paddington, Qld	249.99	''	01/03/01
Dr Wilfred Michael Grenfell, Unit 16, 288 Casuarina Drive, Nightcliff, NT	245.31	''	29/08/01
Mrs Susan Fay Loewensohn, 65 Holt Ave, Cremorne, NSW	125.00	''	''
Mr Phillip Martin & Mrs Heather Ann Martin, "P. & H. Martin Super Fund A/c", C/- Sai Group, PO Box 946, Unley, SA	141.00	''	''
Ms Margaret Redden, C/- Post Office, Geranium, SA	134.94	''	01/03/01

Mr Gavin Michael Ross, 1/137 Ryans Road, Northgate, Qld	650.00	”	”
Samor Investments Pty Limited, “Rouvain Super Fund A/c”, Suite 1, Level 1, Edgecliff Centre, 203–233 New South Head Road, Edgecliff, NSW	2,999.95	”	”
Mr Alexander Reed Naughton-Smith, 9 Beale Court, Templestowe	201.50	”	29/08/01
Mr Matthew John Wallace, 8 Milham Ave, Eastwood, NSW	174.98	”	”
Mr Matthew John Wallace, 8 Milham Ave, Eastwood, NSW	174.98	”	01/03/01
Wokoey Holdings Pty Ltd, 18 Medusa Street, Beauty Point, NSW	499.98	”	”

03095

CONTACT: ELAINE HARE, PHONE: (03) 9611 5714.

Unclaimed Moneys Act 1962

Register of Unclaimed Moneys held by the —

<i>Name of Owner on Books and Last Known Address</i>	<i>Total Amount Due to Owner</i>	<i>Description Of Unclaimed Money</i>	<i>Date when Amount first became Payable</i>
GUD HOLDINGS LIMITED			
	\$		
Mr Colin Stephen Andrew & Mrs Jeanette Fielding Andrew, 22 Parkland Boulevard, Caloundra, Qld	300.00	Cheque	30/04/01
Miss Sally Elizabeth Bartlett, 8 Lotus Crescent, Mulgrave	112.50	”	08/10/01
Mr Yook Fah Chang, Block 508, #09-173 Pasir Ris, Street 52, Singapore 510508	100.05	”	30/04/01
Mr Charles Michael Stanton Crouch, 225 Verney Road East, Graceville, Qld	1,500.00	”	08/10/01
Dunheved Security Services Pty Limited, “Super Fund A/c”, Warrior Place, Dunheved Circuit, St Marys, NSW	375.00	”	”
Mr Paul James Goddon, 25 Evelyn Street, St Kilda East	187.50	”	30/04/01
Mr Peter Charles Graham, 52 Francis Street, Echuca	128.25	”	”
Mr Paul Anthony Henderson, 26 Tooloom Street, Urbenville, NSW	150.00	”	”
Henry Kenneth Herron, 9 Alexander Ave, Mosman, NSW	125.03	”	”
Henry Kenneth Herron, 9 Alexander Ave, Mosman, NSW	25.03	”	08/10/01
Dean Warrick Hodson, 22 Tregarth Street, Wanganui, New Zealand	150.00	”	30/04/01
Dean Warrick Hodson, 22 Tregarth Street, Wanganui, New Zealand	150.00	”	08/10/01
Mr Ian Keith Jobbins, 38 Camelot Street, Tennyson, Qld	247.50	”	30/04/01
Mr Peter William John Keenan, 178A Henderson Valley Road, Henderson, Auckland, NZ	150.00	”	08/10/01
Ms Linda Kilsby, 13 Waterhouse Street, Curtin, ACT	100.05	”	”
Ms Li Liu, 20/222 Church St North, Parramatta, NSW	225.00	”	”
Mr Philip Leonard McRae, 5 Woodhead St, Fitzroy North	270.00	”	”
Mobile Tax Man Pty Ltd,			

“Greg & Maree Valles S/F A/c”, 22 Barrington Street, East Bentleigh	111.08	”	30/04/01
Mr James Henry Havelock Montgomery, 8/1 Boronia Street, Dee Why, NSW	105.00	”	08/10/01
Mr Tony Perri, 3/3 Rennison Street, Parkdale	112.50	”	30/04/01
Mr Tony Perri, 3/3 Rennison Street, Parkdale	112.50	”	08/10/01
Miss Melissa Sharp, 1 Moina Court, Patterson Lakes	322.50	”	”
Mrs Marjorie Louisa Shutt, C/- Shepstone & Wylie, PO Box 205, Durban 4000, South Africa	261.90	”	30/04/01
Ms Peta Signe, The Vice Den, 12 Horton Hill, Epsom, Surrey KT19 8SS, United Kingdom	125.03	”	”
Ms Peta Signe, The Vice Den, 12 Horton Hill, Epsom, Surrey KT19 8SS, United Kingdom	125.03	”	08/10/01
Mrs Jane Francis Trevor Thompson, RMB 337, Burra Road, Gundagai, NSW	825.00	”	08/10/01
Mrs Patricia Whittle, 5 Allen Street, Burnside, SA	172.65	”	”
Mrs Kim Mary Wilson, 39 Valley Drive, Tamworth, NSW	187.50	”	30/04/01

03097

CONTACT: ELAINE HARE, PHONE: (03) 9611 5714.

Unclaimed Moneys Act 1962

Register of Unclaimed Moneys held by the —

<i>Name of Owner on Books and Last Known Address</i>	<i>Total Amount Due to Owner</i>	<i>Description Of Unclaimed Money</i>	<i>Date when Amount first became Payable</i>
HOUSEWARES INTERNATIONAL LIMITED			
\$			
Ms Karen Joy Baynes, “Kelly Baynes-Ridings A/c”, 1A, 18 Albert Road, South Melbourne	100.00	Cheque	18/04/01
Mr Neil Michael Harrington & Mrs Margaret Robyn Harrington, “N. & M. Harrington S/Fund A/c”, 19 Sheridan Court, Heathmont	400.00	”	”
Mr Hugh Mackay, 50 Deepdene Road, Balwyn	12,000.00	”	”
Mr Jack Hobbs Mcconnell & Ms Margaret Rebecca Grose, 48 Kingston Terrace, North Adelaide, SA	200.00	”	”
Parkinson Enterprises Pty Ltd, “Parkinson Super Fund A/c”, 11/7 Anella Avenue, Castle Hill, NSW	200.00	”	”
Miss Mondrey Sin, Ptge Del Dormitiri, De San Francesc 2, 4/2A-08002 Barcelona, Spain	120.00	”	”
Mr Mark Williams, 4 Giles Avenue, Glenelg, SA	400.00	”	”

03098

CONTACT: ELAINE HARE, PHONE: (03) 9611 5714.

Unclaimed Moneys Act 1962

Register of Unclaimed Moneys held by the —

<i>Name of Owner on Books and Last Known Address</i>	<i>Total Amount Due to Owner</i>	<i>Description Of Unclaimed Money</i>	<i>Date when Amount became Payable</i>
INVESTOR GROUP LIMITED			
	\$		
Ms Regina Bachrach, PO Box 32, Richmond	400.00	Cheque	02/11/01
Ms Regina Bachrach, PO Box 32, Richmond	400.00	"	04/05/01
Ms Joyce Alexandra Blackler, C/- Roger Yelland & Co, PO Box 245, Malvern	100.00	"	02/11/01
Ms Joyce Alexandra Blackler, C/- Roger Yelland & Co, PO Box 245, Malvern	100.00	"	04/05/01
John Richard Britton, C/- Byron Moore Journeaux Ltd, 257 Collins Street, Melbourne	300.00	"	02/11/01
John Richard Britton, C/- Byron Moore Journeaux Ltd, 257 Collins Street, Melbourne	300.00	"	04/05/01
Mr Geoffrey Catt & Mrs Mavis Catt, 17B Harrow Road, Somerton Park, SA	122.40	"	"
Mary Leigh Forrest, 34 Tourello Road, Mt Eliza	100.00	"	02/11/01
Mary Leigh Forrest, 34 Tourello Road, Mt Eliza	100.00	"	04/05/01
Barbara Gardiner, 15/24 Springfield Avenue, Toorak	100.00	"	02/11/01
Barbara Gardiner, 15/24 Springfield Avenue, Toorak	100.00	"	04/05/01
Jampac Investments Pty Ltd, C/- P. P. P., PO Box 47, Highett	400.00	"	02/11/01
Jampac Investments Pty Ltd, C/- P. P. P., PO Box 47, Highett	400.00	"	04/05/01
Lendora Pty Limited, "Meredith Family Fund A/c", 20 Werrington Street, Burradoo, NSW	322.52	"	02/11/01
Lendora Pty Limited, "Meredith Family Fund A/c", 20 Werrington Street, Burradoo, NSW	322.52	"	04/05/01
Mrs Elizabeth Loughnan, 21 Canterbury Road, Toorak	100.00	"	02/11/01
Mrs Elizabeth Loughnan, 21 Canterbury Road, Toorak	100.00	"	04/05/01
Maitland Manor Pty Ltd, 53 Rose Street, Essendon	412.84	"	04/05/01
Mr Robert John Merrilees, "Heron Way Super A/c", 9 Mrs Macquarie Drive, Frenchs Forest, NSW	186.28	"	"
Perbright Pty Ltd, "J. G. & C. M. Reid S/F A/c", PO Box 3103, Mildura	125.40	"	02/11/01

03099

CONTACT: ELAINE HARE, PHONE: (03) 9611 5714.

Unclaimed Moneys Act 1962

Register of Unclaimed Moneys held by the —

<i>Name of Owner on Books and Last Known Address</i>	<i>Total Amount Due to Owner</i>	<i>Description Of Unclaimed Money</i>	<i>Date when Amount first became Payable</i>
ION LIMITED			
	\$		
Argus Nominees Pty Ltd, "Halstead Super Fund A/c", 25 Kingsley Street, Camberwell	275.00	Cheque	24/09/01
Argus Nominees Pty Ltd, "Halstead Super Fund A/c", 25 Kingsley Street, Camberwell	225.00	"	17/04/01
Mrs Maxine June Baird, Selwood Road, Learmonth	123.75	"	24/09/01
Mrs Maxine June Baird, Selwood Road, Learmonth	101.25	"	17/04/01
BMT Nominees Pty Ltd, C/- Berne Murray & Tout, CML Building, 14 Martin Place, Sydney, NSW	37.50	"	24/09/01
BMT Nominees Pty Ltd, C/- Berne Murray & Tout, CML Building, 14 Martin Place, Sydney, NSW	112.50	"	17/04/01
Mr Stephen Michael Canavan & Ms Janine Lesley Acton, 25 Morshead St, Melton South	112.50	"	"
Dembart Pty Ltd, PO Box 59, Kilsyth	110.00	"	24/09/01
Flagstaff Investments Pty Ltd, trading as Papoucci Imports, Level 1, George Street, Double Bay, NSW	225.00	"	17/04/01
Gleval Holdings Pty Ltd, 26 Golden Avenue, Chelsea	112.75	"	24/09/01
Rosemary Hearnden, 132 Were Street, Brighton Beach	137.50	"	"
Rosemary Hearnden, 132 Were Street, Brighton Beach	112.50	"	17/04/01
Mr Ken Hirodo, C/- Mr D. Farquharson, Finco Consultants Pty Ltd, 60 Ross Street, Toorak	1,254.00	"	24/09/01
Mr Ken Hirodo, C/- Mr D. Farquharson, Finco Consultants Pty Ltd, 60 Ross Street, Toorak	1,026.00	"	17/04/01
Ernest Martin McDonald Hunter, C/- Peninsula & Torres Strait Health Authority, PO Box 5465 Cairns, Qld	275.00	"	24/09/01
Ernest Martin McDonald Hunter, C/- Peninsula & Torres Strait Health Authority, PO Box 5465 Cairns, Qld	225.00	"	17/04/01
David Anthony Klinger, 1/5 The Esplanade, Balmoral Beach, NSW	412.50	"	24/09/01
Poh Kow Lee, 14 Garden Street, East Hawthorn	412.50	"	"
Poh Kow Lee, 14 Garden Street, East Hawthorn	337.50	"	17/04/01
Mrs Debbie Draga Lozankoski, 182 Plenty River Drive, Greensborough	225.00	"	"
Ms Gina Minutella, 32 Mellor Avenue, Lockleys, SA	192.50	"	24/09/01
Mountain Services Ltd, C/- Phillip Rundle, PO Box 95, Moore, Stephens House, Port Vila, Vanuatu, South Pacific	27,981.25	"	"
Miss Elenor Schneider, Paas Highland Mills, New York 10930, United States of America	115.50	"	"
Ms Kan Ti Pang, C/- C. A. Lenny, PO Box 139, Caulfield South	550.00	"	"

Ms Kan Ti Pang, C/- C. A. Lenny, PO Box 139, Caulfield South	450.00	”	17/04/01
Mr Leonard Mark Pasalich & Ms Mary Pasalich, 21 McCaskill Way, Noranda, WA	178.75	”	24/09/01
Mr Leonard Mark Pasalich & Ms Mary Pasalich, 21 McCaskill Way, Noranda, WA	146.25	”	17/04/01
Mr Huat Lee Phua, Block 2, Normanton Park, #21-145 0511 Singapore	162.25	”	24/09/01
Mr Huat Lee Phua, Block 2, Normanton Park, #21-145 0511 Singapore	132.75	”	17/04/01
Mr John Wilson Rives, “Rives – Hudson Family A/c”, 8 Harrison Crescent, Hawthorn	302.63	”	”
Mr Fred Alexander Roberg, 29 Avelin Street, Hampton	165.00	”	24/09/01
Mrs Laraine Shelton, PO Box 58, Seaford	112.50	”	17/04/01
Mr Michael Robert Simonetti, 36 Meridian Dr, Mullaloo, WA	137.50	”	24/09/01
Mr Michael Robert Simonetti, 36 Meridian Dr, Mullaloo, WA	112.50	”	17/04/01
Mr Stephen William Smith, 1/16 Vautier Street, Elwood	268.13	”	24/09/01
Mr Frank Anderson Stephens, 6796 Arbutus Street, Arvada, Colorado 80004, United States	108.13	”	”
Mr Joseph Vogrinc, PO Box 550, Batemans Bay, NSW	375.01	”	17/04/01
Mrs Lydian Kaye Wheen, 6 Craig Road, Donvale	37.50	”	24/09/01
Mrs Apang Woong, 840 Dandenong Road, PO Box 125, East Caulfield	1,536.70	”	”
Mrs Apang Woong, 840 Dandenong Road, PO Box 125, East Caulfield	1,257.30	”	17/04/01

03100

CONTACT: ELAINE HARE, PHONE: (03) 9611 5714.

Unclaimed Moneys Act 1962

Register of Unclaimed Moneys held by the —

<i>Name of Owner on Books and Last Known Address</i>	<i>Total Amount Due to Owner</i>	<i>Description Of Unclaimed Money</i>	<i>Date when Amount first became Payable</i>
J. B. WERE CAPITAL MARKETS LIMITED			
\$			
Almoritia Pty Limited, “Superannuation Fund A/c”, 54 Woonona Avenue, Wahroonga, NSW	313.01	Cheque	02/04/01
Almoritia Pty Limited, “Superannuation Fund A/c”, 54 Woonona Avenue, Wahroonga, NSW	349.71	”	01/10/01
Awh Investments Pty Ltd, 25 Gurner St, Paddington, NSW	417.35	”	02/04/01
Mrs Doreen Priscilla Pearl Beaurepaire & Mr George Stewart Moffat, 8 Highgate Hill, Toorak	1,043.37	”	”

Mrs Shirley Jean Cameron, "Pension Fund A/c", Level 15, 309 Kent Street, Sydney, NSW	573.42	"	31/12/01
Ms Anna Christine Campbell, 14 Wilks Avenue, Malvern	349.71	"	01/10/01
Mr Geoffrey Gordon Cash, 2 Brewster Place, Duffy, ACT	122.99	"	03/09/01
Mrs Gwendoline Jessie Collett, C/- M. L. McAlpine, 78 Boundary Street, Roseville, NSW	482.22	"	15/03/01
Ms Elizabeth Scott Coombe, "E. S. Coombe Super A/c", GPO Box 814, Adelaide, SA	208.67	"	02/04/01
Ms Elizabeth Scott Coombe, "E. S. Coombe Super A/c", GPO Box 814, Adelaide, SA	233.14	"	01/10/01
Gaba Pty Ltd, "Super Fund Account", PO Box 161, Toukley, NSW	3,495.29	"	02/04/01
Mrs Kathleen Gee, Apartment 59, Marraki Apartments, 93 Smith Street, Darwin, NT	521.68	"	"
Mr Trevor John Gruzin, 11 Doris St, North Sydney, NSW	932.55	"	01/10/01
Mr John Gully, Unit 59, Oak Grange, 695 Hawthorn Road, East Brighton	114.68	"	31/12/01
Mr John Gully, Unit 59, Oak Grange, 695 Hawthorn Road, East Brighton	122.99	"	03/09/01
Haragold Pty Ltd, "K. K. & S. Thornton S/F No 2 A/c", 3 Ti Tree Avenue, Bon Beach	1,165.68	"	01/10/01
Hillingdon Investments Pty Ltd, PO Box 8092, Preston	349.71	"	"
Ms Yu Wan Lam, GPO 314, Gosnells, WA	104.34	"	02/04/01
Mr Lucas Leaman, PO Box 209, Melton	104.34	"	"
Miss Nicole Louise Mayne, 3/2877 Gold Coast Highway, Surfers Paradise, Qld	208.67	"	"
Miss Nicole Louise Mayne, 3/2877 Gold Coast Highway, Surfers Paradise, Qld	233.14	"	01/10/01
Miss Muriel Lyell McAlpine, 78 Boundary Street, Roseville, NSW	964.43	"	15/03/01
Miss Muriel Lyell McAlpine, 78 Boundary Street, Roseville, NSW	860.94	"	03/09/01
Mrs Noelle Marie McCabe & Mr Brian Andre McCabe, PO Box 246, Kyneton	365.18	"	02/04/01
Mr Roy Petch, "Genevieve Zoe Petch A/c", PO Box 148, Black Rock	172.03	"	31/12/01
Mr Peter Riseley, 16 Summerhill Road, Beaumaris	365.18	"	02/04/01
S. Bassili Pty Ltd, "Bassili Super Fund A/c", PO Box 224, Heidelberg	815.98	"	01/10/01
Terenzio Pty Ltd, "Super Fund A/c", 62 Cassowary Street, Doncaster East	860.14	"	31/12/01
Terenzio Pty Ltd, "Super Fund A/c", 62 Cassowary Street, Doncaster East	730.36	"	02/04/01
Terenzio Pty Ltd, "Super Fund A/c", 62 Cassowary Street, Doncaster East	846.11	"	02/07/01
Terenzio Pty Ltd, "Super Fund A/c", 62 Cassowary Street, Doncaster East	815.98	"	01/10/01
Tills Pty Ltd, "Skin Pickering A/c", PO Box 122, Braddon, ACT	1,565.05	"	02/04/01
Mr James Elliot Wilkie, 130 Kooyong Road, Armadale	104.34	"	"

03101

CONTACT: ELAINE HARE, PHONE: (03) 9611 5714.

Unclaimed Moneys Act 1962

Register of Unclaimed Moneys held by the —

<i>Name of Owner on Books and Last Known Address</i>	<i>Total Amount Due to Owner</i>	<i>Description Of Unclaimed Money</i>	<i>Date when Amount first became Payable</i>
MCPHERSON'S LIMITED			
	\$		
Mr Desmond George Anderson, 89 Carbine St, Donvale Estate Late Gary Bowyer,	719.52	Cheque	31/10/01
C/- Diane Debrincat, 52 Romford Rd, Frenchs Forest, NSW	132.00	"	"
Ms Majorie Boyer, 12 Penrhyn Street, Red Hill, ACT	256.44	"	"
Ms Majorie Boyer, 12 Penrhyn Street, Red Hill, ACT	256.44	"	27/04/01
Mr David John Garrett, 73 Albany Road, Herne Bay, Auckland, New Zealand Goncang Pty Ltd, "	255.00	"	"
D. G. A. Superannuation Fund A/c", 89 Carbine Street, Donvale	2,100.00	"	31/10/01
Mr Hayden Stuart Griffiths, 18/67 Sarsfield St, Herne Bay, Auckland, New Zealand	612.00	"	27/04/01
Industrial Consultancy Group, "Superannuation Fund A/c", 8A/263-329 Lorimer Street, Port Melbourne	180.00	"	31/10/01
Industrial Consultancy Group, "Superannuation Fund A/c", 8A/263-329 Lorimer Street, Port Melbourne	180.00	"	27/04/01
J. R. Superannuation Pty Ltd, "J. R. Superannuation Fund A/c", 50 Blackwood Park Road, Ferntree Gully	300.00	"	31/10/01
J. R. Superannuation Pty Ltd, "J. R. Superannuation Fund A/c", 50 Blackwood Park Road, Ferntree Gully	155.00	"	27/04/01
Mr Michael Kurc, 342 St Kilda Street, Brighton	180.00	"	31/10/01
Mr Michael Kurc, 342 St Kilda Street, Brighton	180.00	"	27/04/01
Mr Astley Cyril Morris, 103 Gladstone Street, Orbost	150.00	"	"
Ms Jennifer Margaret Oakley, 75 Holly Road, St Albans, Christchurch, New Zealand	900.00	"	31/10/01
Mr Roy Paterson, 5 Latona Street, Mentone	150.00	"	"
Mrs Maizie Pearson, 7/181-185 Pacific Hwy, Roseville, NSW	120.00	"	"
Project & Financial Engineering Pty Limited, C/- Nicholas Lattimore, Level 24, 1 Macquarie Place, Sydney, NSW	135.00	"	"
Mr Charles William Rudd, 5 Beddows Street, Burwood	152.52	"	"
Mr Charles William Rudd, 5 Beddows Street, Burwood	152.52	"	27/04/01
T. D. Nominees Pty Ltd, "A/c Martin", C/- R. Martin, Beecroft, NSW	150.00	"	31/10/01
Mr Augustine Van Der Heide, C/- Baroid Australia Pty Ltd, 5 Pitino Court, Osborne Park, WA	101.40	"	"

Mr Augustine Van Der Heide, C/- Baroid Australia Pty Ltd, 5 Pitino Court, Osborne Park, WA	101.40	”	27/04/01
Mrs Denise Margaret Vegting, 14 Indra Rd, Blackburn South	240.00	”	31/10/01
Mr Thomas Clyde Vise, 48 Railway Road, Rochester	240.00	”	”
Walton Kolinsky Leahy Pty Ltd, C/- Kennedy & Co, 11/63 Exhibition Street, Melbourne	900.00	”	”
Mrs Christine Dorothy Wood, 5 Muir Court, Mount Stuart, Tas.	130.44	”	”

03102

CONTACT: ELAINE HARE, PHONE: (03) 9611 5714.

Unclaimed Moneys Act 1962

Register of Unclaimed Moneys held by the —

<i>Name of Owner on Books and Last Known Address</i>	<i>Total Amount Due to Owner</i>	<i>Description Of Unclaimed Money</i>	<i>Date when Amount first became Payable</i>
MYOB LIMITED			
	\$		
Mr Bob Bugden, “Bugden Family S/F A/c”, 55 Arthur Circle, Red Hill, ACT	103.16	Cheque	03/05/01
Mr Roger Edward Coolledge, 3 Mincha Avenue, Lower Templestowe	100.00	”	”
Mr Joe Holloway, PO Box 6361, Boroko, Papua New Guinea	125.00	”	”
KJ Consulting Services Pty Limited, “Super Fund A/c”, Level 16, 456 Kent St, Sydney, NSW	740.00	”	”
Mrs Liao Hsiu-Chin Lu, 6 Luton Court, Doncaster East	100.00	”	”
Miss Leanne Shirley Pekalski, 25 Nightingale Drive, Lawnton, Qld	100.00	”	”
Mr Ronald Sampson, 3/69 Airlie Road, Montmorency	100.00	”	”

03103

CONTACT: ELAINE HARE, PHONE: (03) 9611 5714.

Unclaimed Moneys Act 1962

Register of Unclaimed Moneys held by the —

<i>Name of Owner on Books and Last Known Address</i>	<i>Total Amount Due to Owner</i>	<i>Description Of Unclaimed Money</i>	<i>Date when Amount first became Payable</i>
NUFARM LIMITED			
	\$		
Mr John Alkier, 10 Harvest Lane, Beaufort SC 29902, United States of America	550.00	Cheque	09/11/01
Edgar L. Arnold, 6 Willow Spring Lane, Hanover, New Hampshire, USA	171.05	"	"
Edgar L. Arnold, 6 Willow Spring Lane, Hanover, New Hampshire, USA	108.85	"	27/04/01
Mr Brian Ronald Austin, 3-24 Bellevue Hill, Sydney, NSW	501.27	"	09/11/01
Mr Brian Ronald Austin, 3-24 Bellevue Hill, Sydney, NSW	318.99	"	27/04/01
Mr Jim Blome, C/- Agtrol International, 7322 S. W. Freeway, Suite 1400, Houston, Texas 77074, United States of America	1,100.00	"	09/11/01
Raymond Michael Brooks, IMF Resident, Representation Beijing China, C/- International Monetary Fund, Room C- 200 Washington DC 20431, United States of America	132.00	"	"
Estate Late Frederic Alan Butcher & Mr Rex Alan Butcher & Ms Betty Irene Butcher, 44 Pensford Avenue, Kew Gardens, England TW9 4HP	523.88	"	27/04/01
Mr Victor Cheung, 1 Edward Street, Camberwell	231.00	"	09/11/01
Mr Victor Cheung, 1 Edward Street, Camberwell	147.00	"	27/04/01
Dr Frank Tjie Sien Chiu & Mrs Margaret Chiu, 11 Sleeps Hill Drive, Panorama, SA	385.00	"	09/11/01
Commercial Nominees of Australia Ltd, "McNaught Super Fund A/c", GPO Box 1517, Sydney, NSW	110.00	"	"
KI Consultancy Pty Limited, C/- Level 4, 115 Myers Street, Geelong	110.00	"	"
Leewen Pty Ltd, "The Leewen Fund A/c", 125 Cubitt Street, Richmond	140.00	"	27/04/01
Mrs Jean Ann Lyons, 72 Alexandra Road, Erith, Kent DA8 2BA, Great Britain	175.00	"	"
M. & S. Kuperholz Pty Ltd, 67A Lansell Road, Toorak	440.00	"	09/11/01
Robert Hilton MacDuff, C/- Carmel Lazzaro, Level 16, 456 Kent Street, Sydney, NSW	575.74	"	"
Mr Stephen Anthony McCormac & Mr Michael Christopher McCormac & Ms Dale Catherine Campbell, 12 Cox Ave, Nowra, NSW	156.31	"	"
Mr Paul Smith, PO Box 398, Warren, NSW	110.00	"	"
Mr Robert Somerville, 591 Tarneit Road, Werribee	264.00	"	"
Mr Donald Michael Todd, 737 Upper King Parrot Ck Rd, Flowerdale	110.00	"	"
Mr Paul Pau Lok Vun, TB3279 Taman Maju Jaya Jalan, Chong Thien Vun Sin On, 91000 Tawau Sabah, Malaysia	132.00	"	"

03105

CONTACT: ELAINE HARE, PHONE: (03) 9611 5714.

Unclaimed Moneys Act 1962

Register of Unclaimed Moneys held by the —

<i>Name of Owner on Books and Last Known Address</i>	<i>Total Amount Due to Owner</i>	<i>Description Of Unclaimed Money</i>	<i>Date when Amount first became Payable</i>
NUFARM LIMITED			
	NZ \$		
Peter David Aitchison, Apt 2/11 Maida Vale Road, Roseneath, Wellington, New Zealand	331.62	Cheque	09/11/01
Mr Peter Richard Altmann & Mr Robert Narev, "Est H. W. Altmann", 36 Ridings Road, Remuera, Auckland 1105, NZ	253.49	"	27/04/01
William Leslie Brown & Kathleen Lois Hegan, "Philip Hall Family A/c", PO Box 25089, Victoria Street, Christchurch 8030, NZ	397.95	"	"
Mark Bukofzer, PO Box 109244, Newmarket, Auckland, New Zealand	397.95	"	"
Ronald Noel Burgess, 36A Hillsborough Road, Hillsborough, Auckland 1003, New Zealand	853.60	"	"
Avon Leavett Carpenter & Robin Curtis Tunnicliffe, "Gordon Roberts Charitable Account", PO Box 733, Tauranga 3015, New Zealand	436.45	"	27/04/01
Codoro Corporation Limited, 14 Bermuda Road, Remuera, Auckland 1005, New Zealand	1,326.49	"	09/11/01
Gregory Dale, 19 Quona Avenue, Hillsborough, Auckland 1004, New Zealand	132.65	"	"
Michael James Davies & Heather Nancy Davies & Tony John Thomas, 13 King George Avenue, Epsom, Auckland 1003, NZ	366.62	"	27/04/01
Bruce Kenneth Denekamp, C/- Jan McMurray Fletcher, Challenge Building, Private Bag 92114, Auckland 1020, New Zealand	130.94	"	"
Stephen Richard Dix, 70 John Rymer Place, Kohimarama, Auckland 1005, New Zealand	132.65	"	09/11/01
Rex Talbot Everard & Christopher Desmond Western, "Malahide Account", 2-26 Ridge Road, Browns Bay, Auckland 1310, New Zealand	397.95	"	"
Mary Elizabeth Eyre, 50 Helvetia Road, Pukekohe 1800, New Zealand	132.65	"	"
Mr Andrew James Finlayson & Mrs Anne Grace Finlayson, 4 Brassey Road, Wanganui, New Zealand	663.25	"	"
Mr Jack Louis Fong, 42 Parker Avenue, New Lynn, Auckland 1207, New Zealand	642.02	"	"
Mr Jack Louis Fong, 42 Parker Avenue, New Lynn, Auckland 1207, New Zealand	422.48	"	27/04/01
Mr John Charles Foote, Wai-Iti RD 1, Middlemarch, Otago 9170, New Zealand	128.93	"	09/11/01

Estate Mano Te Haara, 11 Belgrave Place, Papakura 1703, New Zealand	297.27	''	''
Estate Mano Te Haara, 11 Belgrave Place, Papakura 1703, New Zealand	195.62	''	27/04/01
Mr Donald James Harvey, 43 Jans Terrace, Oakura, Taranaki 4650, New Zealand	353.11	''	09/11/01
Mr Donald James Harvey, 43 Jans Terrace, Oakura, Taranaki 4650, New Zealand	232.37	''	27/04/01
David James Henton, 45A Wood Street, Papakura, Auckland 1703, New Zealand	159.18	''	09/11/01
Joan Betsy Hepburn, PO Box 134, Queenstown 9197, New Zealand	198.97	''	''
Joan Betsy Hepburn, PO Box 134, Queenstown 9197, New Zealand	130.94	''	27/04/01
Paul Jacob Jansen, PO Box 17-219, Wellington 6033, New Zealand	432.17	''	''
Kowlew Fruits Limited, 5 Entrican Avenue, Remuera, Auckland, New Zealand	174.58	''	''
Richard Desmond Ledgerwood, C/- M. Hewitson, PO Box 5447, Dunedin 9015, New Zealand	349.16	''	''
Mrs Elizabeth Mary Lockhart, PO Box 72051, Papakura, South Auckland, New Zealand	187.30	''	09/11/01
Peter Joseph Luxton & Margaret Rosemary Luxton, 48 Waru Street, Khandallah, Wellington 6005, New Zealand	261.87	''	27/04/01
Eugene Alexander Mak & Alge Mak, PO Box 55116, Mission Bay, Auckland 1130, New Zealand	218.23	''	''
Mary Potter Hospice Foundation Incorporated, PO Box 7442, Attn: Mary Schumacher, Wellington South 6015, New Zealand	132.65	''	09/11/01
Helen Maynard, 37B Kitchener Road, Milford, Auckland 1309, New Zealand	152.55	''	''
Mr Robert Mitchell Miller, Kopuaranga RD 2, Masterton 5921, New Zealand	130.94	''	27/04/01
Rachel Kirsten Mills, PO Box 91420, Auckland, New Zealand	174.58	''	''
David Scott Moncur & Grant Arthur McSkimming, PO Box 21742, Henderson, Auckland 1231, New Zealand	413.07	''	09/11/01
Morrinsville Clothing Manufacturing Limited, C/- Gael Tracey, 76 North Street, Morrinsville 2251, NZ	776.88	''	27/04/01
Mr Peter John O'Brien & Mr Blair Kelvin Headford, PO Box 5703B, Owairaka, Auckland, New Zealand	397.95	''	09/11/01
Kerry Gray Payne & Janet Euphemia Payne, 117 Ngapuhi Road, Remuera, Auckland 1005, New Zealand	436.45	''	27/04/01
The Presbyterian Church Property Trustees (Onehunga), C/- Rev P. N. Wedde, 75 Grey Street, Onehunga, Auckland 1106, New Zealand	282.56	''	''
Robyn Mary Rackham, 47 Rosella Rd, Mangere East, Auckland 1701, New Zealand	159.18	''	09/11/01
Katherine Mary Purdy Ranfurly, Ohariu Road, Johnsonville RD, Wellington 6004, New Zealand	305.09	''	''
Ms Jean Margaret Richardson, 16 Richmond Hill Road, Richmond Hill, Christchurch 8008, New Zealand	195.13	''	''
Mr Michael Spencer, C/- Mr P. A. Spencer Motor Holdings Limited, Private Bag, Auckland 1020, New Zealand	128.93	''	''
Robert Johnson Stewart,			

84 Wigan Street, Gore 9700, New Zealand	135.12	”	27/04/01
Jonathon Redpath Stokes, 16 Bond Street, Arch Hill, Auckland, New Zealand	139.28	”	09/11/01
James William Allan Strachan, 7 Westleigh Way, Newlands, Wellington 6004, New Zealand	130.94	”	27/04/01
Mr David Desmond Surrey & Mrs Lavina Margret Surrey, 3 RD, New Plymouth 4621, New Zealand	195.36	”	”
Mr Kelly Taukilo, 45 Hill Street, Onehunga, Auckland 1006, New Zealand	219.93	”	09/11/01
Mr Kelly Taukilo, 45 Hill Street, Onehunga, Auckland 1006, New Zealand	144.73	”	27/04/01
David George Todhunter & Robin Joseph Todhunter, 277 Scarborough Street, Kaikoura 7351, New Zealand	192.04	”	”
Jon Lowry Wallace, 14C Melrose Street, New Plymouth 4601, New Zealand	261.87	”	”
Mr Peter De Laval Willis, 31 Queen Street, Cambridge 2351, New Zealand	174.43	”	09/11/01

03106

CONTACT: ELAINE HARE, PHONE: (03) 9611 5714.

Unclaimed Moneys Act 1962

Register of Unclaimed Moneys held by the —

<i>Name of Owner on Books and Last Known Address</i>	<i>Total Amount Due to Owner</i>	<i>Description Of Unclaimed Money</i>	<i>Date when Amount first became Payable</i>
OAKTON LIMITED			
	\$		
Mr Christopher John Bartlett & Mrs Melanie Bamping Bartlett, “C. J. Bartlett Family A/c”, 20 Maydena Place, Burnie, Tas.	100.00	Cheque	30/03/01
Mr Allan John Brice, Rangelea Park, RSD 523, Woodside, SA	100.00	”	”
Calibre Asset Management Pty Limited, PO Box 84, South Melbourne	800.00	”	”
Mr Mark Carrazzo, 8 Otterington Grove, East Ivanhoe	100.00	”	”
Mr Shane Anthony Cooper, PO Box 6024, St Kilda Road Central	105.00	”	27/06/01
Ms Rosemary Downey, Unit 2, 5 Vista Grove, Toorak	100.00	”	30/03/01
Mr Rafal Gasiorek, Unit 21, 95 Noble Street, Noble Park	140.00	”	27/06/01
Mr Rafal Gasiorek, Unit 21, 95 Noble Street, Noble Park	200.00	”	30/03/01
Matthew John Hampshire, 1/269 Trafalgar Street, Annandale, NSW	200.00	”	”
Mr Marjan Ilkov, 35 Supply Drive, Epping	150.00	”	30/11/01
Ms Peta Joynson, 130 Lunga Street, Camp Hill, Qld	150.00	”	30/03/01
Mrs Ebo Juniu, “Junius Super Fund A/c”, PO Box 237, Wahroonga, NSW	148.00	”	”
Mr Paul Kostas, 8 Kelborn Close, Greensborough	106.96	”	27/06/01
Mr Paul Kostas, 8 Kelborn Close, Greensborough	152.80	”	30/03/01

Dr Henry Salvatore Kristall, "Henry S. Kristall S/Fund A/c", 2A Fifth Avenue, St Peters, SA	180.00	"	"
Dr Henry Salvatore Kristall, "H. S. Kristall Super A/c", 2A Fifth Avenue, St Peters, SA	100.00	"	"
Dr Ulhas Srinivas Lad & Dr Geeta Ulhas Lad, "U. S. & G. U. Lad Super Fund A/c", PO Box 40, Blackmans Bay, Tas.	160.00	"	"
Mr George Alexander Mack, PO Box 32, Vermont	160.00	"	"
Ms Cynthia Melbourne & Mr Nigel Melbourne, PO Box 3009, Launceston, Tas.	120.00	"	"
Mr Russell Alfred Middleton, 4 Ladbrooke Square, London W11 3IX, United Kingdom	380.00	"	"
Mr Jeff Mitchell, 25 Weemala Road, Northbridge, NSW	400.00	"	"
Mr Peter John Moore & Mrs Henriette Moore, "Peter John Moore S/Fund A/c", 17 Wilks Avenue, Malvern	100.00	"	"
Mr Shane Francis O'Sullivan, PO Box 17, Seymour	150.00	"	"
P. H. Brand & Associates Pty Ltd, "P. & V. Brand Super Fund A/c", PO Box 782, Blackwood, SA	100.00	"	"
Prins-13 Pty Ltd, C/- Glenister & Co, Business Lawyers, PO Box 405, Heidelberg	100.00	"	"
Prue Lloyd Pty Ltd, "Family A/c", PO Box 1027, Deniliquin, NSW	200.00	"	"
Reece Superannuation Pty Ltd, "Reece Super Fund A/c", C/- Pitcher Partners, GPO Box 5193AA, Melbourne	200.00	"	"
Richmond Bridge Pty Ltd, 25 Spofforth Street, Mosman, NSW	2,000.00	"	"
RT Crause Pty Limited, "Crause Super Fund A/c", PO Box 1448, Neutral Bay, NSW	280.00	"	"
Mr Andrew Russell, "Muglease Staff S/Fund A/c", 57 Fairbairn Road, Toorak	100.00	"	"
Mr Kevin Edwin Scribner, "Scribner Retirement Fund A/c", 9 Alimar Road, Glen Waverley	200.00	"	"
Mr John Thomson, 33 Warleigh Grove, Brighton	400.00	"	"
T. S. & M. A. Keyes Construction Pty Ltd, "Ian & Olga Super Fund A/c", Level 1, 306A Crown Street, Wollongong, NSW	143.00	"	"
Valmarl Pty Ltd, "ANZ Margin Lending A/c", 31 Seaward Loop, Sorrento, WA	300.00	"	30/11/01
Valmarl Pty Ltd, "ANZ Margin Lending A/c", 31 Seaward Loop, Sorrento, WA	140.00	"	27/06/01
Valmarl Pty Ltd, "ANZ Margin Lending A/c", 31 Seaward Loop, Sorrento, WA	200.00	"	30/03/01
Mr Mark Antony Stephen Weston, 13 Brittan Terrace, Lyttelton, Christchurch, New Zealand	164.42	"	"
Mr Peter Geoffrey White, 7 Clitus Avenue, Burwood	126.00	"	"

03107

CONTACT: ELAINE HARE, PHONE: (03) 9611 5714.

Unclaimed Moneys Act 1962

Register of Unclaimed Moneys held by the —

<i>Name of Owner on Books and Last Known Address</i>	<i>Total Amount Due to Owner</i>	<i>Description Of Unclaimed Money</i>	<i>Date when Amount first became Payable</i>
PROGRAMMED MAINTENANCE SERVICES LIMITED			
\$			
Mr Robin Bishop & Ms Gillian Turner, "Dragon Super Fund A/c", 2/66 King Street, Sydney, NSW	100.00	Cheque	25/07/01
Mrs Phillipa Stuart Bryant & Ms Amanda Bryant & Mr Timothy Bryant, Bryant Super Fund A/c", PO Box 94, South Hobart, Tas.	305.20	"	"
Mrs Margaret Catherine Fitton, 10 Eva Street, Morphett Vale, SA	120.00	"	"
Mr Alastair Galloway, 6 Wenke Court, East Doncaster Gordany Superannuation Nominees Pty Ltd, "Super Fund A/c", PO Box 2117, Camberwell West	131.00	"	"
Gordany Superannuation Nominees Pty Ltd, "Super Fund A/c", PO Box 2117, Camberwell West	200.00	"	"
Gordany Superannuation Nominees Pty Ltd, "Super Fund A/c", PO Box 2117, Camberwell West	250.00	"	24/01/01
Mr Bruce Patterson, 1/122 Grafton Road, Roseneath, Wellington, New Zealand	200.00	"	25/07/01
Mrs Valerie Mae Stuart, PO Box 1413, Bathurst, NSW	134.00	"	"
Mr Graeme McFarlane Tosh, GPO Box 1559, Darwin, NT	200.00	"	"

03110

CONTACT: ELAINE HARE, PHONE: (03) 9611 5714.

Unclaimed Moneys Act 1962

Register of Unclaimed Moneys held by the —

<i>Name of Owner on Books and Last Known Address</i>	<i>Total Amount Due to Owner</i>	<i>Description Of Unclaimed Money</i>	<i>Date when Amount first became Payable</i>
PROMEDICUS LIMITED			
\$			
Australian Investments United Pty Ltd, 5 St Andrews Place, Indooroopilly, Qld	187.50	Cheque	29/06/01

03108

CONTACT: ELAINE HARE, PHONE: (03) 9611 5714.

Unclaimed Moneys Act 1962

Register of Unclaimed Moneys held by the —

<i>Name of Owner on Books and Last Known Address</i>	<i>Total Amount Due to Owner</i>	<i>Description Of Unclaimed Money</i>	<i>Date when first Amount became Payable</i>
RAY WHITE (GLENROY)			
	\$		
V. & E. Delaney, 16 Morwell Crescent, Dallas Star Home Builders, 15B Rokewood Crescent, Meadow Heights	597.60	Cheque	24/04/98
Abdul-Hadi Abbas Abd & Rhaya Jabbar Al-Ibrahimi, 74 Senna Court, Thomastown	300.00	"	28/10/96
Peter Patto and Selem Patto, 1 Ford Street, Wangaratta	100.00	"	19/12/96
	200.00	"	11/10/96
03186 CONTACT: ALF SHABA, PHONE: (03) 9300 3711.			

Unclaimed Moneys Act 1962

Register of Unclaimed Moneys held by the —

<i>Name of Owner on Books and Last Known Address</i>	<i>Total Amount Due to Owner</i>	<i>Description Of Unclaimed Money</i>	<i>Date when first Amount became Payable</i>
REECE AUSTRALIA LIMITED			
	\$		
Ms Phillis E. Booth, 23 Barloa Road, Balwyn Bridgehead Properties Pty Ltd, C/- Peter Bate, 174 Albert Street, Windsor	3,072.00	Cheque	24/10/01
Mr Nicholas McVay, 29 Philip Street, Bondi, NSW	640.00	"	"
	112.00	"	"
03111 CONTACT: ELAINE HARE, PHONE: (03) 9611 5714.			

Unclaimed Moneys Act 1962

Register of Unclaimed Moneys held by the —

<i>Name of Owner on Books and Last Known Address</i>	<i>Total Amount Due to Owner</i>	<i>Description Of Unclaimed Money</i>	<i>Date when Amount first became Payable</i>
RIO TINTO LIMITED			
	\$		
Mr Julian Digby Abey & Mr Colin Boltman, 43 Monomeath Avenue, Canterbury	1,895.31	Cheque	14/09/01
Mr Pulitano Aholima, 56 Lander Crescent, Invercargill, New Zealand	749.92	"	06/04/01
Mr Pulitano Aholima, 56 Lander Crescent, Invercargill, New Zealand	423.77	"	14/09/01
Mr Michael Clifton Ahrens, C/- Baker & McKenzie, 50 Bridge Street, Sydney, NSW	2,625.07	"	06/04/01
Dr Francis L. Archer, 301 Lennox Street, Richmond	152.08	"	"
Mr Michael Armstrong, "Armstrong Super Fund A/c", GPO Box 1525, Sydney, NSW	126.93	"	14/09/01
Miss Susan Margaret Austin, 12 Gravesend Street, Colac	239.97	"	06/04/01
Miss Susan Margaret Austin, 12 Gravesend Street, Colac	135.60	"	14/09/01
Mr Richard Avero, PO Box 53, Panguna, Bougainville, PNG	113.71	"	06/04/01
Miss Margaret Elizabeth Bagot, 12 Park Terrace, Gilberton, SA	394.20	"	14/09/01
M/S Margery Mona Bailey, 25 Onslow Avenue, Auckland 3, New Zealand	107.43	"	06/04/01
Mr Michael John Bantick, 6 Ewing Avenue, Kingston Beach, Tas.	106.73	"	"
Dr Barrie Bardsley & Dr Malcolm Hickey, "VCAH Foundation A/c", PO Box 317, East Melbourne	404.61	"	"
Dr Barrie Bardsley & Dr Malcolm Hickey, "VCAH Foundation A/c", PO Box 317, East Melbourne	228.64	"	14/09/01
Mrs Ethel Margaret Barwise, 63 Second View Avenue, Beachlands Auckland, NZ	115.10	"	06/04/01
Mrs Katharine Christine Batten, 33 Abbotsford Terrace, Devonport Auckland, New Zealand	214.86	"	"
Mrs Katharine Christine Batten, 33 Abbotsford Terrace, Devonport Auckland, New Zealand	121.41	"	14/09/01
Mr Brian Darnton Bayston & Mrs Barbara Jane Hadley, C/- McCracken & McCracken, 150 Queen St, Melbourne	124.17	"	06/04/01
Mr Michael Andre Benjamin & Mr David John Hayes, C/- B. H. I., PO Box 69, Potts Point, NSW	110.92	"	"
Mrs Susan Grace Jackson Bing & Mr Rodney Disney Davidson, Level 42, 80 Collins Street, Melbourne	275.55	"	"
Mrs Susan Grace Jackson Bing & Mr Rodney Disney Davidson, Level 42, 80 Collins Street, Melbourne	155.71	"	14/09/01

Est Mr Alan Blatchford, Bayview Gardens Nursing Home, 90–96 Annum Road, Bayview, NSW	112.35	”	”
Estate Late Marinus Boer Landweg, 18 4458 Bd’s-Heer Arendskerke, The Netherlands	189.05	”	06/04/01
Estate Late Marinus Boer Landweg, 18 4458 Bd’s-Heer Arendskerke, The Netherlands	106.83	”	14/09/01
Mr Warren Borsje & Mrs Mandy Nicole Borsje, 5/34 Eildon Road, St Kilda	394.20	”	”
Ms Stella Ngaere Bransgrove & Mr Charles W. T. Bransgrove & Mr Stephen David Eichstaedt, “Bransgrove Family A/c”, 11 Kellyville Heights, New Plymouth, New Zealand	642.49	”	06/04/01
Ms Stella Ngaere Bransgrove & Mr Charles W. T. Bransgrove & Mr Stephen David Eichstaedt, “Bransgrove Family A/c”, 11 Kellyville Heights, New Plymouth, New Zealand	363.06	”	14/09/01
Ms Ivy Eutat Branson, Unit 57, 416 St Kilda Road, Melbourne	204.20	”	”
Ms Kristine Clare Brook, 9 Cleveley Ave, Kings Langley, NSW	173.00	”	06/04/01
Mr Gregory Paul Browne & Mr Peter Hal Taylor, “Stairmaster Super Fund A/c”, C/- PO Box 412, Stones Corner, Qld	174.40	”	”
Mr Peter John Brudzinski, 15 Scotts Road, #03-02 Thong Teck Building, Singapore 2282218	749.92	”	”
Mr Peter John Brudzinski, 15 Scotts Road, #03-02 Thong Teck Building, Singapore 2282218	423.77	”	14/09/01
Mrs Durkje Petronella Brusse, 53 William Edward Street, Longueville, NSW	359.96	”	06/04/01
Mrs Durkje Petronella Brusse, 53 William Edward Street, Longueville, NSW	203.41	”	14/09/01
Mrs Jessie Mary Burns, 1 Granter Street, East Brighton	105.65	”	”
Dr Thomas Vincent Byrne, 179 Ninth Avenue, St Lucia, Qld	143.71	”	06/04/01
Ms Kerrie Therese Cameron, 47 Middle Head Rd, Mosman, NSW	139.52	”	”
Miss Mary Cameron, 49A Walpole Street, Kew	2,655.76	”	”
Miss Mary Cameron, 49A Walpole Street, Kew	1,500.72	”	14/09/01
Miss Mary Cameron, 49A Walpole Street, Kew	1,046.40	”	06/04/01
Miss Mary Cameron, 49A Walpole Street, Kew	591.30	”	14/09/01
Virginia Lucille Cartwright & Jay Arthur Swope, 813 Brighton Road, Ocean View, Dunedin, New Zealand	104.64	”	06/04/01
Mrs Ann Chobanoff, 34 Sandalwood Ave, Woodlands, WA	154.87	”	”
Churcher Superannuation Fund Pty Ltd, C/- Schoenfeld & Partners, 492 St Kilda Road, Melbourne	106.04	”	14/09/01
Mr Dennis John Clague & Mrs Anne Aldith Clague, “Clague Family A/c”, Arlington Va 22203	149.98	”	06/04/01
Clanranald Pty Ltd, C/- D. C. Allert, PO Box 494, Glenelg, SA	1,043.61	”	”
Mr William James Clarke & Mrs Sandra Elizabeth Clarke, “William James Clarke, Decd”, Devonpark, Dunkeld	749.92	”	”
Mr Allan Edward Clifton, 20 Christie Court, Karratha, WA	599.94	”	”
Mr Allan Edward Clifton, 20 Christie Court, Karratha, WA	339.01	”	14/09/01

Clisdell's Strata Management Parramatta Pty Limited, "Haarminy Superannuation A/c", PO 2500, Castle Hill, NSW	186.96	"	06/04/01
Mr Philip Raymond Cockell, Suite 109, 102 Longueville Road, Lane Cove, NSW	177.39	"	14/09/01
Estate Late Ronald Ivan Cole, Cole Burt & Co, PO Box 206, Greensborough	243.62	"	"
Estate Late Francis Hugh Collingridge, C/- 37 Ashleigh Ave, Bridgwater, Somerset TA6 6AX, UK	585.29	"	06/04/01
Estate Late Francis Hugh Collingridge, C/- 37 Ashleigh Ave, Bridgwater, Somerset TA6 6AX, UK	330.73	"	14/09/01
Mr Graeme Louis Collinson, PO Box 9423, New Market, Auckland, New Zealand	145.10	"	06/04/01
Computershare Registry Services Pty Ltd, Level 12, 565 Bourke Street, Melbourne	921.53	"	"
Computershare Registry Services Pty Ltd, Level 12, 565 Bourke Street, Melbourne	520.74	"	14/09/01
Mrs Maree Kathleen Conquest, 17 Munro Street, Brighton	118.26	"	"
Mr David Alan Cooper, 635 Ridley Street, Karratha, WA	599.94	"	06/04/01
Mr David Alan Cooper, 635 Ridley Street, Karratha, WA	339.01	"	14/09/01
Mr William Rodolph Cornish & Mr William Davidson Inglis, "E. E. Cornish Family A/c", C/- BDO Nelson Parkhill, 248 Flinders Street, Adelaide, SA	662.72	"	06/04/01
Mr William Rodolph Cornish & Mr William Davidson Inglis, "E. E. Cornish Family A/c", C/- BDO Nelson Parkhill, 248 Flinders Street, Adelaide, SA	374.49	"	14/09/01
Ms Dorothy Pauline Markham, Mr Anthony Richard Cottrell, 188A Devonport Road, Tauranga, New Zealand	287.77	"	"
Mr Stephen Ernest Nigel Creese, 11 Narooma Place, Port Melbourne	423.77	"	"
Mrs Jani Carolyn Culf, 36 Chapman Street, Port Macquarie, NSW	272.39	"	"
Mr Joseph Michael Daley, 13 Cluny Park, Singapore 259622	315.32	"	06/04/01
Mr Joseph Michael Daley, 13 Cluny Park, Singapore 259622	178.18	"	14/09/01
Mr Lucien Darre, C/- H. Cumines, 428 George Street, Sydney, NSW	323.69	"	06/04/01
Mr Lucien Darre, C/- H. Cumines, 428 George Street, Sydney, NSW	182.91	"	14/09/01
Estate Late Dulcie Noel Deeley, C/- 165 Lakes Creek Road, North Rockhampton, Qld	106.73	"	06/04/01
Mr Ronald George Denley, 54 Medowie Road, Oldbar, NSW	149.98	"	"
Mr John Dixon, 7/120 Soi, 6 Pongpet Village, Changwattana, Bangkok, Thailand	167.42	"	"
Mr Robert Emerson Doane, C/- Day Cutten Ltd, GPO Box 663, Adelaide, SA	613.89	"	"
Mr Robert Emerson Doane, C/- Day Cutten Ltd, GPO Box 663, Adelaide, SA	346.90	"	14/09/01
Mr Stephen Peter Dolan, Q1616 QVB Post Shop, Queen Victoria Building, NSW	525.99	"	06/04/01
Mr Athol Brian Doonan, 36 McLennan Street, Mooroopna	191.84	"	"
Mr Athol Brian Doonan, 36 McLennan Street, Mooroopna	108.41	"	14/09/01

M/S Isobel Arnott Durack, 34 Melvista Ave, Claremont, WA	109.52	''	06/04/01
Mrs Margaret Anne Easton, 8 Sherwood St, Maylands, WA	275.94	''	14/09/01
Mr Paul David Eckhoff, 19 Wallace St, Roslyn, Dunedin, NZ	382.28	''	06/04/01
Mr Paul David Eckhoff, 19 Wallace St, Roslyn, Dunedin, NZ	216.02	''	14/09/01
Mr Stuart Douglas Edge, PO Box 17, Dampier, WA	133.94	''	06/04/01
Mr Stuart William Edmunds & Miss Camilla Edwina Edmunds, "Edmunds Fam Enterprises A/c", Unit 9/47 Forrest Avenue, East Perth, WA	225.32	''	''
Mr Stuart William Edmunds & Miss Camilla Edwina Edmunds, "Edmunds Fam Enterprises A/c", Unit 9/47 Forrest Avenue, East Perth, WA	127.33	''	14/09/01
E. G. & H. Nominees Pty Ltd, C/- Touche Ross Share Registry, GPO Box 2975EE, Melbourne	401.12	''	06/04/01
E. G. & H. Nominees Pty Ltd, C/- Touche Ross Share Registry, GPO Box 2975EE, Melbourne	226.67	''	14/09/01
Elbaton Holdings Pty Ltd, C/- Mrs I. M. Beston, 48 Olola Avenue, Vaucluse, NSW	392.05	''	06/04/01
Elbaton Holdings Pty Ltd, C/- Mrs I. M. Beston, 48 Olola Avenue, Vaucluse, NSW	221.54	''	14/09/01
Mr Henry Robinson Elsdale, C/- Cameron Stockbrokers Ltd, Level 5, 10 Spring Street, Sydney, NSW	121.38	''	06/04/01
Mrs Dianne Mavis Evans, 17 Garden Street, Kogarah, NSW	270.03	''	14/09/01
Mrs Penelopy Anne Evans, 11 Livingstone Avenue, Pymble, NSW	163.94	''	06/04/01
Mrs Joan Elizabeth Evershed, 2 Chapman St, Bellerive, Tas. Evershot Pty Ltd, C/- Mr P. Chadwick, 36 Somerset Street, Mosman, NSW	115.80	''	''
Evershot Pty Ltd, C/- Mr P. Chadwick, 36 Somerset Street, Mosman, NSW	230.91	''	''
Fioma Pty Ltd, "Pearce Super Fund A/c", 41 Boscombe Avenue, City Beach, WA	130.48	''	14/09/01
Firth Engineering Co Pty Ltd, 4 Penrhyn Avenue, Pymble, NSW	449.95	''	06/04/01
Firth Engineering Co Pty Ltd, 4 Penrhyn Avenue, Pymble, NSW	225.32	''	''
Firth Engineering Co Pty Ltd, 4 Penrhyn Avenue, Pymble, NSW	127.33	''	14/09/01
Ms Fiona Elizabeth Fitzpatrick, 3405/1 Kings Cross Road, Rushcutters Bay, NSW	477.86	''	06/04/01
Ms Fiona Elizabeth Fitzpatrick, 3405/1 Kings Cross Road, Rushcutters Bay, NSW	270.03	''	14/09/01
Mr Nigel Keith-Flowers, 6/50-52 Earle Street, Cremorne, NSW	157.68	''	''
Mrs Sandra Ford, 20 Kirstina Road, Glen Waverley	139.52	''	06/04/01
Mrs Barbara D. Fowler, 52 Waterhouse Ave, St Ives, NSW	212.77	''	''
Mrs Annie Clara Franzen, 23 Clifford Ave, Fairlight, NSW	143.01	''	''
Mr William George Frogley, 18 Second Ave, St Peters, SA	1,744.00	''	''
Mr William George Frogley, 18 Second Ave, St Peters, SA	985.50	''	14/09/01

Functional Rehabilitation & Sports Physiotherapy Centre Pty Ltd, PO Box 623, St Marys, NSW	279.04	”	06/04/01
Functional Rehabilitation & Sports Physiotherapy Centre Pty Ltd, PO Box 623, St Marys, NSW	157.68	”	14/09/01
Mr Nicholas Blair Garnham, 2 Vivian Grove, Hawthorn	198.12	”	06/04/01
Mrs Anne Monica Gell, Unit 3, 164 Macpherson Street, Bronte, NSW	156.96	”	”
Mr Arthur John Gentle, 68 Padbury Way, Karratha, WA	635.84	”	14/09/01
Mr Brenton Gill, Suite 205, 184 Blues Point Road, McMahons Point, NSW	394.20	”	”
Mrs Elizabeth Doreen Glass, Piawaning, WA	131.15	”	06/04/01
Miss Kristine Mary Gleeson, 11 Mile Road, Tynong	115.10	”	”
Mrs Lyndsay Marion Goodacre, PO Box 1432, Cleveland, Qld	128.51	”	14/09/01
Mr Keith Battersby Gordon, C/- The Manager Bank of NSW, 111–113 Crown Street, Wollongong, NSW	306.25	”	06/04/01
Mr Keith Battersby Gordon, C/- The Manager Bank of NSW, 111–113 Crown Street, Wollongong, NSW	173.05	”	14/09/01
Estate Late Abraham Arthur Gottlieb, 215 Chestnut Hill Rd, Chestnut Hill, MA 02167-1313, USA	352.99	”	06/04/01
Estate Late Abraham Arthur Gottlieb, 215 Chestnut Hill Rd, Chestnut Hill, MA 02167-1313, USA	199.47	”	14/09/01
Mr Peter James Goudie, C/- Inco Pacific Limited, 15th Floor, 19-27 Wyndham Street, Central Hong Kong	782.71	”	06/04/01
Mr Peter James Goudie, C/- Inco Pacific Limited, 15th Floor, 19-27 Wyndham Street, Central Hong Kong	442.29	”	14/09/01
Mr John Michael Gove, Flat 8, 61 Marne St, South Yarra	108.13	”	06/04/01
Mr David John Grant, 4 Lock Maree Drive, Vaucluse, NSW	128.36	”	”
Mr Stuart Joseph Green, 65 Castlewood Drive, Castle Hill, NSW	209.28	”	”
Mr Stuart Joseph Green, 65 Castlewood Drive, Castle Hill, NSW	118.26	”	14/09/01
Estate Late Eileen Margaret Griffiths, C/- Public Trustee NSW, Box 441, Broken Hill, NSW	276.25	”	06/04/01
Estate Late Eileen Margaret Griffiths, C/- Public Trustee NSW, Box 441, Broken Hill, NSW	156.10	”	14/09/01
Mr Robin Arthur Grigg, “Barrosa Station”, Mt Somers, Rd 1, Ashburton 8300, New Zealand	217.60	”	”
Mr Brian Gurr, 8 Glenfern Road, Howick, Auckland, NZ	122.08	”	06/04/01
Miss Elizabeth Margaret Hall, 6 Electra St, Williamstown	447.16	”	”
Miss Elizabeth Margaret Hall, 6 Electra St, Williamstown	252.68	”	14/09/01
Mr Donald George Halverson, 9 Monash Court, Clermont, Qld	127.33	”	”
Estate Late Mavis Irene Hamilton, C/- Mr R. Hamilton, PO Box 362, Darlinghurst, NSW	535.06	”	06/04/01
Mrs Muriel Isabel Handley, 15 Southerland Cottage, 75 Thames Street, Box Hill	193.55	”	14/09/01

Ms Gillian Christine Hann, PO Box 1529, Orange, NSW	680.86	''	06/04/01
Mr David Hannah Jnr, St Helena, Armidale, NSW	334.85	''	''
Mr David Hannah Jnr, St Helena, Armidale, NSW	189.22	''	14/09/01
Mr Stephen David Hansen, 4 Safari Crescent, Johnsonville, Wellington 6004, NZ	197.10	''	''
Miss Jenny May Harris, Flat 4, 14 Fairfax Road, Bellevue Hill, NSW	149.98	''	06/04/01
Mrs Phyllis May Harris, 43 Gordon Ave, Hamilton, NSW	115.80	''	''
Mr Michael James Hayne, 156 Adelaide Street East, Clayfield, Qld	1,078.53	''	14/09/01
Mr David Hayward, 12 Robieson Street, Roseneath, Wellington, New Zealand	324.38	''	06/04/01
Mrs Helen Mary Hedigan, 53-55 Rosehill Rd, Lower Plenty Est Hilda Lucy Henderson	128.90	''	14/09/01
C/- William Morphett Henderson, Unit 61, 8 Briggs Road, Springwood, Qld Est Hilda Lucy Henderson	643.19	''	06/04/01
C/- William Morphett Henderson, Unit 61, 8 Briggs Road, Springwood, Qld	363.45	''	14/09/01
Mrs Winsland Dorothy Highfield, C/- Kent Wilson Mellor Olsson, PO Box 74, Adelaide, SA	493.20	''	06/04/01
Mrs Margaret Hincks, PO Box 66, Swansea, NSW	31.15	''	''
H. L. Dawson & Son Pty Ltd, PO Box 229, Paddington, NSW	301.36	''	''
H. L. Dawson & Son Pty Ltd, PO Box 229, Paddington, NSW	170.29	''	14/09/01
Mr Denis Robert Hogg, C/- Moneywise, PO Box 255, Collins Street West	236.52	''	''
Miss Leonie Margaret Horne, PO Box 160, Woodside, SA	187.65	''	06/04/01
Miss Leonie Margaret Horne, PO Box 160, Woodside, SA	106.04	''	14/09/01
Mrs Rosslyn Elizabeth Humphries, PO Box 9, George Town, Tas.	115.80	''	06/04/01
Mr Grahame William Hurrell, GPO Box 9431, Hong Kong Ilepeach Pty Limited,	107.43	''	''
C/- Economy Concrete Tanks Retirement Fund 1980, PO Box 317, Albury, NSW Ilepeach Pty Limited,	487.62	''	''
C/- Economy Concrete Tanks Retirement Fund 1980, PO Box 317, Albury, NSW Est Mr William Lyle Irwin,	275.55	''	14/09/01
C/- Mian Phillips & Co, PO Box 308, Balwyn North	4,606.25	''	06/04/01
Mrs Beverley Raie Jamieson, PO Box 1200, Midland, WA	184.86	''	''
Mrs Beverley Raie Jamieson, PO Box 1200, Midland, WA	104.46	''	14/09/01
Mr Darryn Lindsay Johnson, Att: Kim Griffiths, Private Bag 1999, Dunedin 9020, New Zealand	118.59	''	06/04/01
Mr Ian Campbell Johnston, Ashbourne, SA	198.82	''	''
Mr Ian Campbell Johnston, Ashbourne, SA	112.35	''	14/09/01
Mr Aylwin Frank Theodore Halligan-Jolly, 46 Queenscliffe Road, Doubleview, WA	231.60	''	06/04/01
Mr Aylwin Frank Theodore Halligan-Jolly, 46 Queenscliffe Road, Doubleview, WA	130.87	''	14/09/01
Mr Ian Charles Jones, PO Box 101563, North Shore Mail Centre, Auckland, New Zealand	261.60	''	06/04/01
Mr Trevor Jones & Mr Stewart Erskine & Mr Chancellor Yeow, 4 Leo Close, Elermore Vale, NSW	119.99	''	''

Mr Bernard Kalb & Mrs Phyllis Kalb, 6409 Danville Court, Rockville, Maryland 20852, USA	235.79	”	”
Mr Bernard Kalb & Mrs Phyllis Kalb, 6409 Danville Court, Rockville, Maryland 20852, USA	33.24	”	14/09/01
Mr Bernard Kalb, 6409 Danville Court, Rockville, Maryland 20852, USA	332.06	”	06/04/01
Mr Bernard Kalb, 6409 Danville Court, Rockville, Maryland 20852, USA	187.64	”	14/09/01
Mr Wai Fai Kan, PO Box 506, Eastwood, NSW	375.31	”	06/04/01
Mr Wai Fai Kan, PO Box 506, Eastwood, NSW	212.08	”	14/09/01
Mr Loh Meen Kang, 44 Toh Tuck Road, #03-05 Goodluck Garden, Singapore 2159	599.94	”	06/04/01
Mr Loh Meen Kang, 44 Toh Tuck Road, #03-05 Goodluck Garden, Singapore 2159	339.01	”	14/09/01
Mr Bruno Kasciukaitis & Mrs Petricia Kasciukaitis, 105 Murchison Crescent, Dampier, WA	123.48	”	06/04/01
Mr Peter Kemeny & Mrs Anna Veronica Kemeny, 17 Kanowar Avenue, Killara, NSW	495.30	”	”
Mr Peter Kemeny & Mrs Anna Veronica Kemeny, 17 Kanowar Avenue, Killara, NSW	279.88	”	14/09/01
Mr Charles William Alan Kerr, 4 Gerald Avenue, Roseville, NSW	317.41	”	06/04/01
Mr Charles William Alan Kerr, 4 Gerald Avenue, Roseville, NSW	179.36	”	14/09/01
Mrs Marian Gould Kerr, 4 Gerald Avenue, Roseville, NSW	145.46	”	”
Miss Muriel Grace Kierath, 123 Grosvenor Road, Mt Lawley, WA	223.23	”	06/04/01
Miss Muriel Grace Kierath, 123 Grosvenor Road, Mt Lawley, WA	126.14	”	14/09/01
Mr Keith Ernest King & Geoffrey Oliver Wiles, Deceased, C/- Bar's Leaks (Aust) P/L, 42-44 Kareena Rd, Miranda, NSW	399.72	”	06/04/01
Dr George Koo & Mrs Cheong Ian-Chon Koo, 19A Wilson Road, Jardine's Lookout, Hong Kong	235.79	”	”
Dr George Koo & Mrs Cheong Ian-Chon Koo, 19A Wilson Road, Jardine's Lookout, Hong Kong	133.24	”	14/09/01
Dr George Chia Gee Koo & Mrs Cheong Ian-Choon Koo, 19A Wilson Road, Jardine's Lookout, Hong Kong	256.72	”	06/04/01
Dr George Chia Gee Koo & Mrs Cheong Ian-Choon Koo, 19A Wilson Road, Jardine's Lookout, Hong Kong	145.07	”	14/09/01
Dr Gabriel Krausz, "Superannuation Fund A/c", C/- Barry Mendel Frank, Level 53, 19-29 Martin Place, Sydney, NSW	394.20	”	”
Chee Weng Lai, 34A Neerim Road, Caulfield	749.92	”	06/04/01
Chee Weng Lai, 34A Neerim Road, Caulfield	423.77	”	14/09/01
Est Late Lily Landy, C/- Mr M. Landy Moreland Fincance Corp (Vic), 591 Bridge Road, Richmond	230.91	”	06/04/01
Est Late Lily Landy, C/- Mr M. Landy Moreland Fincance Corp (Vic), 591 Bridge Road, Richmond	130.48	”	14/09/01

Mr Ian Guildford Lane, 36 Queens Drive, Ashburton, New Zealand	153.47	''	06/04/01
Mr Nicholas Lattimore, C/- Macquarie Bank Limited, 12th Floor, 20 Bond Street, Sydney, NSW	15.10	''	''
Mr Charles Lay, 10/314 Bondi Road, Bondi, NSW	263.00	''	''
Mrs Marta Lazarus, PO Box 291, Ashfield, NSW	149.98	''	''
Miss Kim Khoek Lee, 2 Loxley Court, East Doncaster	209.28	''	''
Mrs Andree Leffers, 'wirruna', 242 Main Creek Road, Main Ridge	149.98	''	''
Mrs Beryl Marie Leske, 1102 Peninsula Tower, 37 Glen Street, Milsons Point, NSW	209.28	''	''
Mr Stephen Lewis, 25 Phyllis Avenue, Kanwal, NSW	749.92	''	''
Mr Stephen Lewis, 25 Phyllis Avenue, Kanwal, NSW	423.77	''	14/09/01
Mr Willem Lindemans, PO Box 316, Caulfield East	221.14	''	06/04/01
Mr Willem Lindemans, PO Box 316, Caulfield East	124.96	''	14/09/01
Mrs Edna Christina Little, 23 The Grove, Mosman, NSW	3,012.93	''	06/04/01
Lockley Services Pty Ltd, 8 Macro Court, Rowville	697.60	''	''
Lockley Services Pty Ltd, 8 Macro Court, Rowville	394.20	''	14/09/01
Mr Laurence Robert Lockwood, Flat 8, 746 Beaufort Street, Mt Lawley, WA	322.99	''	06/04/01
Mr Laurence Robert Lockwood, Flat 8, 746 Beaufort Street, Mt Lawley, WA	182.51	''	14/09/01
Mrs Janice Ruth Logan, 85 Felstead St, Everton Park, Qld	783.40	''	06/04/01
Mrs Janice Ruth Logan, 85 Felstead St, Everton Park, Qld	442.69	''	14/09/01
Luke Marriott Enterprises Pty Limited, "Peter Marriott Staff SF A/c", 72 Roberts Street, Essendon	354.78	''	''
Mr Anthony John Hale Lumsden, C/- BBL Curran Mullens Ltd, 7th Floor, 301 George Street, Sydney, NSW	146.50	''	06/04/01
Dr Patrick Francis Lyons, "Pat Lyons Pers S/F A/c", 59 Augusta Road, Lenah Valley, Tas.	174.40	''	''
Mr Duncan Angus MacGregor, C/- Mt Isa East Post Office, 102 Webb Street, Mt Isa, Qld	1,762.84	''	''
Mr Duncan Angus MacGregor, C/- Mt Isa East Post Office, 102 Webb Street, Mt Isa, Qld	996.14	''	14/09/01
Mr Marshall James White MacLean, Fenwick Stud, 1740 Donnybrook Road, Yan Yean, Whittlesea	1,036.63	''	06/04/01
Mr Michael Roebourne Madigan, C/- Salomon Smith Barney, GPO Box 2419, Adelaide, SA	236.52	''	14/09/01
Miss Ellen Bridget Maher, Lower Heytesbury, RMB 8225, Timboon	115.80	''	06/04/01
Mr Bruce Makin, 103 Gannons Road, Caringbah, NSW	110.92	''	''
Mrs Rowena Katherine Mankelow, 15/19-21 Orpington Street, Ashfield, NSW	152.08	''	''
Mrs Colleen Lindsay Manning, 10 Kamarooka Street, Beaudesert, Qld	111.62	''	''
Mr Peter Edward Marchant, 400 Bruce Crescent, Wallarah, NSW	139.52	''	''
M. Mariyappa, C/- Miss M. Jayalakshmi, J/56/1(Upstairs)Nanjegowda La, Dodda Mavalli, Bangalore 560004, Karnataka State, India	216.81	''	14/09/01
Mr Carmelo Marotta, 35 View Street, Mont Albert	118.59	''	06/04/01

Mr Douglas John Anderson Marr, 90 Yabba St, Ascot, Qld	124.17	''	''
Mr Dieter Karl Martens & Mrs Gloria Grace Martens, 14/123 Main Street, Kangaroo Point, Qld	254.26	''	14/09/01
Mr Eric Robert Phillip Martin, Unit 4, 'lumeall', 26 Windsor Street, Nundah, Qld	299.97	''	06/04/01
Mr Eric Robert Phillip Martin, Unit 4, 'lumeall', 26 Windsor Street, Nundah, Qld	169.51	''	14/09/01
Mr Tony James Martin, 134 Wombat Street, Young, NSW	102.49	''	''
Mr Colin John Mason, 12 Alma Street, Southport, Qld	599.94	''	06/04/01
Mr Colin John Mason, 12 Alma Street, Southport, Qld	339.01	''	14/09/01
Mrs Fiona Macdougall Mathews, 24 Roberts Avenue, Randwick, NSW	451.35	''	06/04/01
Mrs Fiona Macdougall Mathews, 24 Roberts Avenue, Randwick, NSW	255.05	''	14/09/01
Ms Audrey Margaret Rea Matthews & Mr Peter John Matthews, "Estate R. W. Matthews A/c", 9 Templeton Street, Sale	198.82	''	06/04/01
Ms Audrey Margaret Rea Matthews & Mr Peter John Matthews, "Estate R. W. Matthews A/c", 9 Templeton Street, Sale	112.35	''	14/09/01
Rex William Matthews, Deceased & Mrs Audrey Margaret R. Matthews, 9 Templeton Street, Sale	111.95	''	''
Mr Richard Alexander Matthews, PO Box 410, Kununurra, WA	599.94	''	06/04/01
Mr Richard Alexander Matthews, PO Box 410, Kununurra, WA	339.01	''	14/09/01
Maxileen Pty Ltd, 5 Blackwood Avenue, West Hobart, Tas.	3,313.60	''	06/04/01
Mr Robert Evelyn Gurney Mayhew, La Vapora Guadiaro, Prov De Cadiz, Spain	177.19	''	''
Mr Robert Evelyn Gurney Mayhew, La Vapora Guadiaro, Prov De Cadiz, Spain	100.13	''	14/09/01
Dr Andrew Dalgarno McCredie & Miss Janet McCredie & Mr James Dalgarno McCredie, Flat 13, 18 Lansell Rd, Toorak	122.78	''	06/04/01
Miss Patricia Anne McDonagh, 11 Stanley Street, Pascoe Vale South	200.91	''	''
Miss Patricia Anne McDonagh, 11 Stanley Street, Pascoe Vale South	113.53	''	14/09/01
Mr Anthony Robert McDonald, 1111 Jabbarup Place, Tom Price, WA	225.32	''	06/04/01
Mr Anthony Robert McDonald, 1111 Jabbarup Place, Tom Price, WA	127.33	''	14/09/01
Mr Rodney Peter McDonald & Ms Doreen Elizabeth McDonald, "McDonald Unit A/c", PO Box 2622, Nerang, Qld	661.86	''	''
Mr Robert Colin McIntosh, 62 Rockhampton Road, Yeppoon, Qld	203.70	''	06/04/01
Mr Robert Colin McIntosh, 62 Rockhampton Road, Yeppoon, Qld	115.11	''	14/09/01
Mr Geoffrey Thomas McKay, Flat 2, 65 Weed Street, Manly, NSW	225.32	''	06/04/01
Mr Geoffrey Thomas McKay, Flat 2, 65 Weed Street, Manly, NSW	127.33	''	14/09/01

Mr Stuart James McLardy, PO Box 4184, Kalgoorlie, WA	149.98	''	06/04/01
Mrs Dorothy McPhee, 15 Carmody Road, St Lucia, Qld	364.15	''	''
Ernest John McShane, Deceased, C/- Rita McShane, 56 Argyll Street, Chadstone	281.83	''	''
Ernest John McShane, Deceased, C/- Rita McShane, 56 Argyll Street, Chadstone	159.26	''	14/09/01
Mr Jeffrey Simon Melvaine, 1 Highlands Avenue, Wahroonga, NSW	126.14	''	14/09/01
Mr Campbell Ian Message, 21 Alva Ave, Park Orchards	697.60	''	06/04/01
Millar Holdings SDB BHD, C/- The Liquidator, Suite 100, 6th Floor, Wisma Yakin Jalan Masjid India, Kuala Lumpur, Malaysia 50100	530.87	''	''
Millar Holdings SDN BHD, C/- The Liquidator, Suite 100, 6th Floor, Wisma Yakin Jalan Masjid India, Kuala Lumpur, Malaysia 50100	299.99	''	14/09/01
Mrs Sheila Margaret Milson, Flat 9, 2 Motts Avenue, Bondi, NSW	128.36	''	06/04/01
Mr David Scott Moncur & Mr Grant Arthur McSkimming, PO Box 21742, Henderson, Auckland, New Zealand	212.08	''	14/09/01
Mrs Stella Moore, Unit 4, 3 Bedford Road, Ringwood	132.54	''	06/04/01
Moran Management Services Pty Ltd, 8 Timmis Avenue, Cheltenham	149.98	''	''
Mrs Christine Dorothy Mary Moriarty, 109 Alexandra Avenue, Toorak Gardens, SA	138.12	''	''
Mr Richard James Morley, C/- D. L. Cameron, PO Box 275, Geelong	194.63	''	''
Mr Richard James Morley, C/- D. L. Cameron, PO Box 275, Geelong	109.98	''	14/09/01
Mrs Elizabeth Buchanan Nabarro, C/- W. Percival Minell & Co, 33 Bligh Street, Sydney, NSW	135.33	''	06/04/01
Mr Michael John Nash, "Michael Nash Super Fund A/c", 59 Woodville Street, Rockhampton, Qld	195.33	''	06/04/01
Mr Michael John Nash, "Michael Nash Super Fund A/c", 59 Woodville Street, Rockhampton, Qld	110.38	''	14/09/01
National Australia Trustees Limited, "Michael Donohoe NPS A/c", Locked Bag 3280, Melbourne	558.08	''	06/04/01
Mrs Pamela Margaret Ness, 7 Adelong Drive, Cranbrook, Qld	392.62	''	14/09/01
Mr Robert Barry Ness & Mrs Pamela Margaret Ness, "The Ness Family Account", 7 Adelong Drive, Cranbrook, Qld	112.35	''	''
Estate Late Benjamin John Newbold & Mrs Eileen Theresa Newbold, 7 Anne Crescent, Brighton	280.28	''	14/09/01
Mr Allan Ng, Unit 13, 15 Herbert St, St Leonards, NSW	104.64	''	06/04/01
Mr Ian Alan Nicholls Stensviksv, 16 S-392 47 Kalmar, Sweden	136.39	''	14/09/01
Mrs Tui Aroha Nourtier, C/- Sutton, Apt 3A, 313 East, 78th Street, New York NY 10021, USA	416.47	''	06/04/01

Mrs Tui Aroha Nourtier, C/- Sutton, Apt 3A, 313 East, 78th Street, New York NY 10021, USA	235.34	''	14/09/01
Mr Michael William Oley, Pt Keliiah Equatorial Mining, PO Box 269, Balikpapan Kalimantan Tihur, Indonesia	599.94	''	06/04/01
Mr Michael William Oley, Pt Keliiah Equatorial Mining, PO Box 269, Balikpapan Kalimantan Tihur, Indonesia	339.01	''	14/09/01
Mrs Mary Oliphant, 225 Wattletree Road, Malvern Mr Bernard Lewis O'Neil,	212.08	''	''
10 Square De La Tour, Mauborg 75007, Paris, France	282.53	''	06/04/01
Mr Bernard Lewis O'Neil, 10 Square De La Tour, Mauborg 75007, Paris, France	159.65	''	14/09/01
Mr John Tony Orlovic, PO Box 117, Kempas Creek, NSW	104.64	''	06/04/01
Mrs Mary Jean Page, 71 Wongala Cres, Beecroft, NSW	109.52	''	''
Mr John Paradee, C/- Mr Tony Greenwood, 555 Willoughby Road, Willoughby, NSW	223.23	''	''
Mr John Paradee, C/- Mr Tony Greenwood, 555 Willoughby Road, Willoughby, NSW	126.14	''	14/09/01
Mr Scott Lee Pease, "S. Pease A/c", RD4, Waipawa, NZ	118.26	''	''
Mr Stephen Anthony Perdue, 603 Canning Highway, Alfred Cove, WA	375.31	''	06/04/01
Mr Stephen Anthony Perdue, 603 Canning Highway, Alfred Cove, WA	133.24	''	14/09/01
Perpetual Nominees Limited, "Auubsl A/c", L19, 1 Castlereagh Street, Sydney, NSW	15,543.23	''	06/04/01
Perpetual Nominees Limited, "DRP A/c", L19, 1 Castlereagh Street, Sydney, NSW	32,089.60	''	''
Mr Kenneth Charles Peterson, Unit 39, 2 Spruson Street, Neutral Bay, NSW	145.80	''	''
Mr Pietro Picchi, 123 Church Street, Hawthorn	260.90	''	''
Mr Pietro Picchi, 123 Church Street, Hawthorn	147.43	''	14/09/01
Mr Wayne James Pidgeon & Mrs Sharon Lindsay Pidgeon, 52 Ganet St, Mackay, Qld	143.09	''	''
Dr David George Pocock & Mrs Jennifer Clair Pocock, 426 Spring Valley Lane, Altamonte Springs, Florida FLA 32714, USA	191.84	''	06/04/01
Mr Jason Michael Power, 25 Denva Road, Tinonee, NSW	209.28	''	''
Mr Peter Thomas Power, 2 Spring Street, Fitzroy	129.06	''	''
Mr Richard John Murray-Prior & Mrs Ilma Flora Murray-Prior, 40 Nelson Street, South Townsville, Qld	310.43	''	''
Estate Late Annie Proctor, C/- 2065 Pittwater Road, Bayview, NSW	1,012.22	''	''
Estate Late Annie Proctor, C/- 2065 Pittwater Road, Bayview, NSW	571.98	''	14/09/01
Mr John Howard Quane, 126 Hillview Cres, Whitfield, Qld	106.04	''	06/04/01
Mrs Patricia Mary Quirk, Lighthouse Cottage, Barrenjoey Headland, Palm Beach, NSW	235.09	''	''
Mrs Patricia Mary Quirk, Lighthouse Cottage, Barrenjoey Headland, Palm Beach, NSW	132.85	''	14/09/01
Est Late Jack Gilbert Radford, C/- Mrs J. K. Radford, 8 Fernleigh Gardens, Rose Bay, NSW	272.06	''	06/04/01
Est Late Jack Gilbert Radford, C/- Mrs J. K. Radford, 8 Fernleigh Gardens, Rose Bay, NSW	153.74	''	14/09/01

Mr Barry Maxwell Ramsay, PO Box 325, Weipa, QLD	599.94	''	06/04/01
Mr Barry Maxwell Ramsay, PO Box 325, Weipa, QLD	339.01	''	14/09/01
Mrs Lucy Escott Retalic, 595 Glynburn Road, Hazelwood Park, SA	424.55	''	''
Mrs Helen Lyall Rollo, 203 Domain Road, South Yarra	251.83	''	06/04/01
Mrs Helen Lyall Rollo, 203 Domain Road, South Yarra	142.31	''	14/09/01
John Peter Dillon Rowley, Deceased, C/- Rowlandson & Co, PO Box 275, Castle Hill, NSW	725.50	''	06/04/01
John Peter Dillon Rowley, Deceased, C/- Rowlandson & Co, PO Box 275, Castle Hill, NSW	409.97	''	14/09/01
Royal New Zealand Plunket Society (Inc), PO Box 1480, Dunedin, New Zealand	1,093.14	''	06/04/01
Royal New Zealand Plunket Society (Inc), PO Box 1480, Dunedin, New Zealand	617.71	''	14/09/01
Royal NZ Plunket Society (Inc), "Auckland District Account", PO Box 1480, Dunedin, NZ	558.08	''	06/04/01
Royal NZ Plunket Society (Inc), "Auckland District Account", PO Box 1480, Dunedin, NZ	315.36	''	14/09/01
R. R. Dunn Nominees Pty Ltd, "Dunn Super Fund A/c", GPO Box 4365QQ, Melbourne	1,005.21	''	''
Estate Late Isaac Rudzki, C/- Ledermans, Level 2, 20 Queen Street, Melbourne	138.36	''	''
Mr Heinz Rufenacht, C/- Gallen Guild & Johnston, PO Box 240, Canberra City, ACT	187.65	''	06/04/01
Mr Heinz Rufenacht, C/- Gallen Guild & Johnston, PO Box 240, Canberra City, ACT	106.04	''	14/09/01
Saints & Sinners Pty Ltd, "Superfund A/c", 111 Northwood Road, Northwood, NSW	613.89	''	06/04/01
Saints & Sinners Pty Ltd, "Superfund A/c", 111 Northwood Road, Northwood, NSW	346.90	''	14/09/01
Mrs Winifred Lucy Salter, 45 Fairbairn Road, Toorak	399.72	''	06/04/01
Mrs Winifred Lucy Salter, 45 Fairbairn Road, Toorak	225.88	''	14/09/01
Mr Scott Monteith Samuel, 30 Beech Street, East Malvern	375.31	''	06/04/01
Mr Hiroshi Sato, 403 Dorufu, 2-21-4 Tairamachi Meguroku, Tokyo, Japan	225.32	''	''
Mr Hiroshi Sato, 403 Dorufu, 2-21-4 Tairamachi Meguroku, Tokyo, Japan	127.33	''	14/09/01
Ms Dianne Kay Scott, "Sarah Egan & Clare Egan A/c", 146 Royale Street, Delacombe	299.97	''	06/04/01
Ms Dianne Kay Scott, "Sarah Egan & Clare Egan A/c", 146 Royale Street, Delacombe	169.51	''	14/09/01
Estate Late Shirley Ruth Scott, 51 Morella Ave, Sefton, NSW	599.94	''	06/04/01
Estate Late Shirley Ruth Scott, 51 Morella Ave, Sefton, NSW	339.01	''	14/09/01
Mr Ami Chand Setu, PO Box 62, Emerald, Qld	326.48	''	06/04/01
Mr Ami Chand Setu, PO Box 62, Emerald, Qld	184.49	''	14/09/01
S. G. M. Marketing Nominees Pty Ltd, "Superannuation Account", PO Box 8278, Carrum Downs	225.32	''	06/04/01
S. G. M. Marketing Nominees Pty Ltd, "Superannuation Account", PO Box 8278, Carrum Downs	127.33	''	14/09/01
Mr Michael David Sharman & Mrs Lynette Anne Sharman, "Super Fund A/c", 1 Power Line Road, Long Plains, SA	197.10	''	''
Mrs Viva Talys Shears, 10 Marion Avenue, Mooroolbark	275.55	''	06/04/01
Mrs Viva Talys Shears, 10 Marion Avenue, Mooroolbark	155.71	''	14/09/01

Shepperton Manor Pty Ltd, 419 Penshurst Street, Roseville, NSW	260.90	''	06/04/01
Shepperton Manor Pty Ltd, 419 Penshurst Street, Roseville, NSW	147.43	''	14/09/01
Mrs Sylvia Mary Cowie Shores, PO Box 2027, Auckland, New Zealand	1,002.45	''	06/04/01
Estate Late Jack Simpson, 46 Brynor Cres, Glen Waverley	187.65	''	''
Estate Late Jack Simpson, 46 Brynor Cres, Glen Waverley	106.04	''	14/09/01
Dr Chih Lee Siow, PO Box 32, Balwyn North	143.09	''	''
Mr Kevin Skelton, C/- PO Box 1711, Boroko NCD, Papua New Guinea	104.64	''	06/04/01
Mr Gareth Dean Smith, Unit 6, 15-17 Park Avenue, Randwick, NSW	237.18	''	''
Mr Gareth Dean Smith, Unit 6, 15-17 Park Avenue, Randwick, NSW	134.03	''	14/09/01
Mrs Margaret Smith, Lot 3, Bryson's Road, Warranwood	184.86	''	06/04/01
Mrs Margaret Smith, Lot 3, Bryson's Road, Warranwood	104.46	''	14/09/01
Mr Philip Smith, 60 Nirvana Street, Malvern East	216.81	''	''
Ms Sally Abbott Smith, 68 Kent Street, Ascot Vale	283.43	''	''
Mr Sidney Edward Smith, 24 Woodend Rd, Ipswich, Qld	139.52	''	06/04/01
St Michael Orthodox Church, Post Office Box 272024, Concord CA, 94527-2024, United States of America	143.49	''	14/09/01
Strahlen Pty Ltd, 9 Bertha Road, Cremorne, NSW	409.49	''	06/04/01
Strahlen Pty Ltd, 9 Bertha Road, Cremorne, NSW	231.40	''	14/09/01
Rev James Maitland Stuckey & Mrs Hannah Jean Stuckey, C/- Edward G. Stuckey, 2 Marengo Crescent, Apollo Bay	150.98	''	''
Miss Julie Taverner, Flat 302/117d Macleay Street, Potts Point, NSW	138.36	''	''
Mr Pravir Atindra Tesiram & Miss Louise Lawton, "The Finlayson-Zolezzi A/c", C/- PO Box 4039, Shortland St, Auckland 1015, NZ	279.04	''	06/04/01
Miss Ham Tieu Nguyen Thi & Miss Thu Hong Nguyen Thi, 112 Broome Street, Maroubra, NSW	111.62	''	06/04/01
Miss Ham Tieu Nguyen Thi, 112 Broome Street, Maroubra, NSW	119.29	''	''
Mr Ian Frederick Thomas, 35 Weemala Road, Northbridge, NSW	204.40	''	''
Mr Ian Frederick Thomas, 35 Weemala Road, Northbridge, NSW	115.50	''	14/09/01
Ms Sharyn Lee Thompson, 42 The Drive, Bardon, Qld	749.92	''	06/04/01
Ms Sharyn Lee Thompson, 42 The Drive, Bardon, Qld	423.77	''	14/09/01
Mr Matthew Colin Thomson, PO Box 8, Chatsworth Island, NSW	174.40	''	06/04/01
Est Mr John Lanham Bradbury Titchener, C/- Merrill Lynch, GPO Box 4322PP, Melbourne	735.27	''	''
Est Mr John Lanham Bradbury Titchener, C/- Merrill Lynch, GPO Box 4322PP, Melbourne	415.49	''	14/09/01
Trans City Nominees Pty Ltd, PO Box N804, Sydney, NSW	375.31	''	06/04/01
Trans City Nominees Pty Ltd, PO Box N804, Sydney, NSW	212.08	''	14/09/01
Claire Isobel Treloar, 99A Waitapa Road, Hataitai, Wellington, New Zealand	460.42	''	06/04/01

Claire Isobel Treloar, 99A Waitapa Road, Hataitai, Wellington, New Zealand	260.17	''	14/09/01
Mr Dane Richard Trezise, 6 Salgado St, Boyne Island, Qld	149.98	''	06/04/01
Mr John Howard Troughton, 32 Pukatea Street, Eastbourne Nth Island, New Zealand	111.62	''	''
Est Late Frank Turner, C/- E. R. Stack & Sons, PO Box 265, Forster, NSW	1,845.15	''	''
Mr Arthur Geoffrey Tyler, 949 25th St, Nw Washington DC 20037, USA	496.69	''	''
Mr Karl Denver Van Buuren, 19 Walsham Road, Blackburn	118.59	''	''
Mr Francois Van Vyve Oude Gracht, 8 2080 Kapellen, Belgium	113.01	''	''
Mr Wilbur John Campbell Vigus, PO Box 128, Glenroy	197.10	''	14/09/01
Vivel Pty Ltd, 9/43 Rockley Road, South Yarra	348.80	''	06/04/01
Vivel Pty Ltd, 9/43 Rockley Road, South Yarra	197.10	''	14/09/01
Wairenga Nominees Limited, 21 Reading Street, Karori, Wellington, New Zealand	140.34	''	''
Mrs Susan Wynn Wallis, 2 Edwin Street, Greenwich, NSW	108.83	''	06/04/01
Estate Late Raymond Crosbie Walsh, C/- Alderdice & Clarke, PO Box 298, Chatswood, NSW	260.90	''	''
Mrs Jean Walters, Unit 3, The Parks, 1 Moore Street, Taringa, Qld	169.51	''	14/09/01
Mr Geoffrey Wardle & Ms Frances Dawn Wardle, "Wardle Superfund A/c", 34 Dickens Street, Blackburn	697.60	''	06/04/01
Estate Late Ellen Mary Watson, 7 Bragge Street, Frankston	502.27	''	''
Estate Late Ellen Mary Watson, 7 Bragge Street, Frankston	177.39	''	14/09/01
Estate Late Forster Brian Weeks, C/- Public Trustee NSW, GPO Box 7, Sydney, NSW	585.29	''	06/04/01
Estate Late Forster Brian Weeks, C/- Public Trustee NSW, GPO Box 7, Sydney, NSW	330.73	''	14/09/01
West Ag Services Pty Ltd, 157 Melbourne Street, North Adelaide, SA	153.47	''	06/04/01
Mr Robert Edward West & Mrs Pamela Anne West, "West Family A/c", 11 Tafquin Street, Panorama, SA	197.10	''	14/09/01
Mr Stephen Lynne Wharton & Mr Christopher Lynne Wharton & Mr Anthony Paul Wharton, C/- Wharton & Co, Level 8, 445 Toorak Road, Toorak	234.39	''	06/04/01
Mr Stephen Lynne Wharton & Mr Christopher Lynne Wharton & Mr Anthony Paul Wharton, C/- Wharton & Co, Level 8, 445 Toorak Road, Toorak	132.45	''	14/09/01
Mrs Ruby Wheller, 29 Birdwood Terrace, Auchenflower, Qld	104.64	''	06/04/01
Mr Eryl Beauchamp Jordan Williams & Mrs Helen Elizabeth Williams, 21 Trevelyan Street, Wayville, SA	117.20	''	''
Miss Mary Eileen Williams, Unit 3, "Belmore", PO Box 203, Wollongong East, NSW	484.83	''	''
Alick G. Wilson, 16 Braithwaite Street, Karori, Wellington, New Zealand	173.70	''	''
Estate Late Flora Wilson, 14725-107A Avenue, Surrey, British Columbia V3R 1V2, Canada	161.84	''	''

Mrs Susan Elizabeth Wilson, Lot 43, Forest Avenue, Mundaring, WA	149.98	”	”
Mr William Wilson, PO Box 61629, Houston, Texas 77208, USA	197.42	”	”
Mr William Wilson, PO Box 61629, Houston, Texas 77208, USA	111.56	”	14/09/01
Mrs Chan Chuk Ming Elizabeth Wong, #1401 - 1236 Bidwell St, Vancouver BC V6G 2K9, Canada	265.79	”	06/04/01
Estate Late Nan Simpson Woods, C/- Stephen Adam Kinloch, 58 Couvereur St, Garran, ACT	253.93	”	”
Mr Simon Wright, 4/58 Fletcher Street, Tamarama, NSW	118.26	”	14/09/01
Mrs Kathleen Vera Younes, 5 Snowball Road, Kalamunda, WA	138.12	”	06/04/01

03112

CONTACT: ELAINE HARE, PHONE: (03) 9611 5714.

Unclaimed Moneys Act 1962

Register of Unclaimed Moneys held by the —

<i>Name of Owner on Books and Last Known Address</i>	<i>Total Amount Due to Owner</i>	<i>Description Of Unclaimed Money</i>	<i>Date when Amount first became Payable</i>
SELECT HARVESTS LIMITED			
	\$		
ACN 075 575 503 Pty Ltd, 20 Jordan Street, Malvern Mr John Atherton & Ms Carole Fletcher, C/- Bourne McLeish Pty Ltd, 11th Floor, 50 Market Street, Melbourne	192.00	Cheque	01/10/01
Christopher Roderick Barrett & Joanna Victoria Holdsworth, PO Box 116, Malvern	240.00	”	”
Civic Image Pty Ltd, “Civic Image Superfund A/c”, 11 Brian Court, Mt Eliza	478.92	”	”
Civic Image Pty Ltd, “Civic Image Superfund A/c”, 11 Brian Court, Mt Eliza	760.00	”	06/04/01
Mr Ian Crotty, PO Box 618, Collins Street West	1,140.00	”	01/10/01
Dellas Pty Ltd, “Dellas Investment A/c”, 11 Anita Street, Beaumaris	183.00	”	”
Mr Peter Raymond De Vercelli, 24 Bellavista Rd, Glen Iris	120.00	”	06/04/01
Grandview Consulting Pty Ltd, “Hemkes Retirement Fund A/c”, 229 Dryburgh Street, North Melbourne	120.00	”	01/10/01
Mrs Siew Yeen Hortle, 18 Sharrow Road, Mitcham	456.00	”	”
Mrs Siew Yeen Hortle, 18 Sharrow Road, Mitcham	253.96	”	06/04/01
Mrs Judith Gwen Hunt, GPO Box 7112, Sydney, NSW	380.94	”	01/10/01
Mr Patrick James Keane & Mr Trevor McGrath, “Keane Retirement Fund A/c”, 1 Neagle Mews, Berwick	107.94	”	”
	140.00	”	06/04/01

Mr Patrick James Keane & Mr Trevor McGrath, "Keane Retirement Fund A/c", 1 Neagle Mews, Berwick	210.00	"	01/10/01
Mr Ashley Collett King & Mrs Amanda King, Box 987, Warrnambool	127.68	"	06/04/01
Rockleigh Engineering Pty Ltd, PO Box 189, Mount Eliza	120.00	"	01/10/01
Mr Clarke James Roycroft & Mr Alan Patrick Hickey, "Hickey & Roycroft S/P Fund", Goonans Road, Bookar Via Camperdown	300.00	"	"
Mr John Whitelegg, PO Box 2174, Mildura	120.00	"	"
Mr Dean Arron Williams, 33 Middle Street, Ascot Vale	101.56	"	06/04/01
Mrs Heather Adele Wilton, PO Box 217, Holbrook, NSW	180.00	"	01/10/01
Winomond Pty Ltd, "Langford Superannuation A/c", 9 York Road, Glen Iris	240.00	"	"

03115

CONTACT: ELAINE HARE, PHONE: (03) 9611 5714.

Unclaimed Moneys Act 1962

Register of Unclaimed Moneys held by the —

<i>Name of Owner on Books and Last Known Address</i>	<i>Total Amount Due to Owner</i>	<i>Description Of Unclaimed Money</i>	<i>Date when Amount first became Payable</i>
SNACK FOODS LIMITED			
	\$		
Mrs Joan Mary Bowey, 2 Humphris Terrace, Jamestown, SA	261.75	Cheque	02/10/01
Burlington Enterprises Pty Ltd, Level 1, 10 Bridge Road, Stanmore, NSW	175.00	"	"
Burlington Enterprises Pty Ltd, Level 1, 10 Bridge Road, Stanmore, NSW	105.00	"	14/03/01
Mr Jack Chia, 299 Si Phraya Road, Bangrak, Bangkok 10500, Thailand	125.00	"	02/10/01
Chanphen Chiarapurk, 299 Si Phraya Road, Bangrak, Bangkok 10500, Thailand	150.00	"	"
Danai Chiarapurk, Unit 2409, Tsuen Wan Industrial Centre, 220-248 Texaco Road, Tsuen Wan, Hong Kong	150.00	"	"
Mr Jack Chiarapurk, 299 Si Phraya Road, Bangrak, Bangkok 10500, Thailand	150.00	"	"
Mr Dominic John Collins, 799 Pacific Highway, Chatswood, NSW	112.50	"	"
Mr Robert Friedman, 5 Lynedoch Avenue, St Kilda East	187.50	"	"
Mrs Jane Gardiner, "Exelplan Pty Ltd A/c", 9 Rathmines Street, Toorak	529.63	"	"
Mr Yahya Bin Mohamed-Ishak, Block 836, Tampines Street, 82 #03-61, Singapore 520836	125.00	"	"

Ms Varathan Sudanthara Thevee Letchme, Apt Block 59, Marine Terrace, #10–103, Singapore 440059	125.00	”	”
Mr Shane Alexander Noble, 10/9–11 Ewos Pde, Cronulla, NSW	529.00	”	14/03/01
Mr Robert Oliphant, C/- BML Software (Aust P/L), 3rd Floor/290 Burwood Road, Hawthorn	250.00	”	02/10/01
Players Group Limited, “Dissenting Shareholders A/c”, C/- Snack Foods Limited, PO Box 328, Balwyn North	734.18	”	”
Players Group Limited, “Dissenting Shareholders A/c”, C/- Snack Foods Limited, PO Box 328, Balwyn North	440.51	”	14/03/01
Prudhoe Corporation Pty Ltd, “East Melbourne Ret Plan A/c”, 76 George Street, East Melbourne	360.00	”	”
Serchix Pty Ltd, 44–46 Lt Ryrrie Street, Geelong	175.00	”	02/10/01
Shelplea Pty Ltd, “Leitch Hasson & Dent No1 A/c”, 416 Crown Street, Surry Hills, NSW	261.75	”	”
Shelplea Pty Ltd, “Leitch Hasson & Dent No1 A/c”, 416 Crown Street, Surry Hills, NSW	157.05	”	14/03/01
Mr Laurence Charles Thornton, 22 Cromer Road, Greenbank, Bristol 855 6JX, United Kingdom	150.00	”	02/10/01
Mr Allan Laurence Trethewey, West Nombi, Mullaley, NSW	150.00	”	”
Mr Allan Lawrence Trethewey, West Nombi, Mullaley via Gunnedah, NSW	100.00	”	”
Mr Premjit Singh Uberoi, 16 Crace St, Weetangera, ACT	100.00	”	”

03114

CONTACT: ELAINE HARE, PHONE: (03) 9611 5714.

Unclaimed Moneys Act 1962

Register of Unclaimed Moneys held by the —

<i>Name of Owner on Books and Last Known Address</i>	<i>Total Amount Due to Owner</i>	<i>Description Of Unclaimed Money</i>	<i>Date when Amount first became Payable</i>
SPC ARDMONA LIMITED			
	\$		
Carolyn Anne Abernethy, 195 Millers Hill Road, Jack River Adenna Pty Limited, C/- Metzke & Allan, PO Box 1031, Shepparton	324.00	Cheque	02/04/01
Blue Heights Pty Ltd, Attn: Mr Peter Francis, 4/39 Robe Street, St Kilda	127.62	”	31/01/01
Blue Heights Pty Ltd, Attn: Mr Peter Francis, 4/39 Robe Street, St Kilda	202.50	”	05/04/01
Wladyslaw Bogdan & Barbra Bogdan & John Bogdan, PO Box 7444, Shepparton	200.00	”	05/11/01
	660.42	”	02/04/01

Wladyslaw Bogdan & Barbra Bogdan & John Bogdan, PO Box 7444, Shepparton	2,377.51	''	05/04/01
Wladyslaw Bogdan & Barbra Bogdan & John Bogdan, PO Box 7444, Shepparton	587.04	''	05/11/01
Wladyslaw Bogdan & Barbra Bogdan & John Bogdan, PO Box 7444, Shepparton	2,348.16	''	''
Dargenio David Boschetti, Deceased, C/- KPMG Peat Marwick, GPO Box 2975EE, Melbourne	356.40	''	05/04/01
Dargenio David Boschetti, Deceased, C/- KPMG Peat Marwick, GPO Box 2975EE, Melbourne	352.00	''	05/11/01
Maxwell Alan Coldwell, RSD Shepparton East Estate Late Kathleen Couch,	146.76	''	''
C/- Morrissy & Deane, PO Box 117, Shepparton Estate Late Kathleen Couch,	826.20	''	05/04/01
C/- Morrissy & Deane, PO Box 117, Shepparton Estate Late Kathleen Couch,	204.00	''	05/11/01
C/- Morrissy & Deane, PO Box 117, Shepparton Estate Late Kathleen Couch,	816.00	''	''
C/- Morrissy & Deane, PO Box 117, Shepparton	229.50	''	02/04/01
D. A. Fairless Pty Ltd, "D. A. Fairless Exec S/F A/c", PO Box 106, Shepparton East	1,014.44	''	05/11/01
Mr Graham Richard Etherington & Mrs Noelene Rose Etherington, C/- Pearl Fund Managers P/L, PO Box 203, Market Street, Melbourne	850.80	''	31/01/01
Estate Late Joseph Feiglin, Post Office Box 21, Nunawading	806.76	''	05/04/01
Alan Ross Ford, 12 Grosvenor Street, Narrandera, NSW	108.96	''	05/11/01
Mr Fortunaro Rocco Gattuso & Mrs Vittoria Gattuso, PO Box 219, Cobram	177.55	''	05/04/01
Mr Fortunaro Rocco Gattuso & Mrs Vittoria Gattuso, PO Box 219, Cobram	175.36	''	05/11/01
Mr Marijan Glajnaric, 38 Glenrowan Drive, Tallai, Qld	200.00	''	''
Glenfor Pty Ltd, RMB 1141, Midland Highway, Benalla	133.58	''	''
Phillip Grandfield, 100 Raglan Street, Mossman, NSW	486.00	''	05/04/01
Dr & La Hazle Pty Ltd, PO Box 225, Wonthaggi	110.97	''	02/04/01
Mr Leslie Roland Hines, PO Box 851, Moonee Ponds	106.86	''	05/11/01
Mrs Valerie Beth Hines, PO Box 851, Moonee Ponds	106.86	''	''
Susanne Howell, 7 Hennessy Avenue, Elwood	353.81	''	05/04/01
Susanne Howell, 7 Hennessy Avenue, Elwood	349.44	''	05/11/01
Kija Pty Ltd, PO Box 458, Lavington, NSW	33.58	''	''
Mrs Colleen Mary Lonzi, Unit 13, 11 Willow St, Essendon	303.75	''	05/04/01
Mrs Colleen Mary Lonzi, Unit 13, 11 Willow St, Essendon	300.00	''	05/11/01
Mr Mario Licciardello, 204 Highett Road, Highett	349.47	''	02/04/01
Mr Alexander A. McLennan, Deceased, Flat 1, 12 Fletcher Street, Essendon	191.81	''	05/04/01
Mr Alexander A. McLennan, Deceased, Flat 1, 12 Fletcher Street, Essendon	189.44	''	05/11/01
McPherson Newspapers Pty Limited, PO Box 204, Shepparton	614.42	''	''
McPherson Newspapers Pty Limited, PO Box 204, Shepparton	978.42	''	31/01/01
McPherson Newspapers Pty Limited, PO Box 204, Shepparton	176.87	''	05/03/01
Michael Meaden, 10 Murray Street, Tocumwal, NSW	129.60	''	05/04/01

Fejzi Neim Meka & Nevres Meka, 5 Corop Place, Kialla	1,378.16	''	05/11/01
Fejzi Neim Meka & Nevres Meka, 5 Corop Place, Kialla	5,512.64	''	''
Estate Late Edward Gilbert Mensforth, C/-Adrian Edward Mensforth, 5 Newbury Court, Ashwood	148.39	''	05/04/01
Estate Late Edward Gilbert Mensforth, C/-Adrian Edward Mensforth, 5 Newbury Court, Ashwood	146.56	''	05/11/01
Estate Late John Wilfred Mitchell, C/- Harrison Dobson & Cottrill, PO Box 8, Benalla	297.78	''	31/01/01
Mt Sturt Pastoral Co Pty Ltd, "The Hotchin Family A/c", PO Box 23, Broken Hill, NSW	534.28	''	05/11/01
Mr Rocco Nicolaci & Ms Maria Nicolaci, Doyles Lane, Shepparton	149.69	''	05/04/01
Mr Rocco Nicolaci & Ms Maria Nicolaci, Doyles Lane, Shepparton	147.84	''	05/11/01
Tom Paraskevas, PO Box 64, Shepparton East	221.29	''	05/04/01
Tom Paraskevas, PO Box 64, Shepparton East	218.56	''	05/11/01
Mr Antonio Perri & Mr Antonio Raco, PO Box 57, Cobram	156.17	''	05/04/01
Mr Antonio Perri & Mr Antonio Raco, PO Box 57, Cobram	154.24	''	05/11/01
Mr George Petrovski, Poplar Avenue, Shepparton	1,594.92	''	''
Guisepe Rachele & Antonio B. Rachele, RMB 250, Shepparton	286.02	''	02/04/01
Mr Angelo Sciacca, PO Box 49, Merrigum	127.44	''	''
Spase Razmovski & Vangelica Razmovski, RMB 1261, Shepparton	593.24	''	05/04/01
Spase Razmovski & Vangelica Razmovski, RMB 1261, Shepparton	585.92	''	05/11/01
Mr Jamie John Reese, PO Box 1431, Shepparton	115.20	''	''
Vitorio Reginato & Germano Reginato, Box 197, Cobram	319.16	''	''
Vitorio Reginato & Germano Reginato, Box 197, Cobram	1,276.64	''	''
Rossmac Nominees Pty Ltd, PO Box 204, Shepparton	400.00	''	''
Mr Angelo Sciacca, PO Box 49, Merrigum	458.78	''	05/04/01
Michele Simonetti & Maria Concetta Simonetti, 10 Warkil Street, Cobram	142.24	''	''
Michele Simonetti & Maria Concetta Simonetti, 10 Warkil Street, Cobram	140.48	''	05/11/01
Robert Ian Sinclair, 87 Batman Avenue, Shepparton	388.80	''	05/04/01
Robert Ian Sinclair, 87 Batman Avenue, Shepparton	108.00	''	02/04/01
Dov Slomin, 56 Howitt Road, Caulfield	283.50	''	''
Dov Slomin, 56 Howitt Road, Caulfield	1,020.60	''	05/04/01
Robert Ian Sinclair, 87 Batman Avenue, Shepparton	108.00	''	02/04/01
Ms Anne Wall-Smith, 43/27 Flinders Lane, Melbourne	151.88	''	05/04/01
Ms Anne Wall-Smith, 43/27 Flinders Lane, Melbourne	150.00	''	05/11/01
Mr Peter Bernard Snider, 77 Erin Street, Richmond	112.80	''	''
Sonnett Pty Ltd, Box 365, Cobram	269.73	''	05/04/01
Sonnett Pty Ltd, Box 365, Cobram	266.40	''	05/11/01
Catherine Eliza Stanford, C/- Stephen Maule & Co, 491 Bourke Street, Melbourne, C/- GPO Box 2975EE, Melbourne	137.38	''	05/04/01
Catherine Eliza Stanford, C/- Stephen Maule & Co, 491 Bourke Street, Melbourne, C/- GPO Box 2975EE, Melbourne	135.68	''	05/11/01
Mr Richard David Alexander Thomas, 56 Lakeside Boulevard, Rowville	133.58	''	''
Santa Rocco Varapodio, Post Office, Lemnos	106.92	''	05/04/01

Luigi Verdi & Franca Verdi, C/- KPMG Peat Marwick, GPO Box 2975EE, Melbourne	137.54	”	”
Luigi Verdi & Franca Verdi, C/- KPMG Peat Marwick, GPO Box 2975EE, Melbourne	135.84	”	05/11/01
Mr Gerard James Versteegen & Mrs Desma Dale Versteegen, RMB 2008, Benalla	212.70	”	31/01/01
L. A. Vizard & C. J. Stephens, 4 Mateo Close, Dandenong North	183.38	”	05/04/01
L. A. Vizard & C. J. Stephens, 4 Mateo Close, Dandenong North	181.12	”	05/11/01
V. & D. Zurcas Holdings Pty Ltd, PO Box 224, Shepparton	462.78	”	02/04/01
Zurcas Coolstores & Packing Company Pty Ltd, 192 Benalla Rd, Shepparton	801.42	”	05/11/01
Zurcas Coolstores & Packing Company Pty Ltd, 192 Benalla Rd, Shepparton	230.70	”	05/03/01

03116

CONTACT: ELAINE HARE, PHONE: (03) 9611 5714.

Unclaimed Moneys Act 1962

Register of Unclaimed Moneys held by the —

<i>Name of Owner on Books and Last Known Address</i>	<i>Total Amount Due to Owner</i>	<i>Description Of Unclaimed Money</i>	<i>Date when Amount first became Payable</i>
SPOTLESS GROUP LIMITED			
	\$		
Abony Nominees Pty Ltd, “The John Roth Family A/c”, PO Box 1049, Huntingdale	345.00	”	21/09/01
Mrs Cornelia Maria Anderson, 70-74 Giles Rd, Redland Bay, Qld	143.36	”	09/03/01
Mr Donald Scott Barker, 26/73 Queens Road, Melbourne	339.25	”	21/09/01
Ms Eileen Bellamy PO Box 165, Albury, NSW	407.10	”	”
Ms Eileen Bellamy PO Box 165, Albury, NSW	336.30	”	09/03/01
Mr Louis Andrew Caulfield, C/- Corporate Registry Services Pty Ltd, GPO Box 505H, Melbourne	193.55	”	21/09/01
Mr Louis Andrew Caulfield, C/- Corporate Registry Services Pty Ltd, GPO Box 505H, Melbourne	159.89	”	09/03/01
Ms Ellen McHendry Chambers, 39 Newhaven Road, East Burwood	126.73	”	21/09/01
Ms Ellen McHendry Chambers, 39 Newhaven Road, East Burwood	104.69	”	09/03/01
Chelsea Pastoral Company Pty Limited, 39 Market Street, Wollongong, NSW	301.76	”	21/09/01

Chelsea Pastoral Company Pty Limited, 39 Market Street, Wollongong, NSW	249.28	''	09/03/01
Mr Edward Cohen, 722 Orrong Road, Toorak	296.88	''	''
Mr Rudyard Brian Crawford, PO Box 177, Caringbah, NSW	131.45	''	21/09/01
Mr Rudyard Brian Crawford, PO Box 177, Caringbah, NSW	108.59	''	09/03/01
Ms Jillian Danne, 75A Lower Dandenong Road, Mentone Deralea Pty Ltd,	249.28	''	''
''Superfund No 1 A/c'', 3 Dalgetty Road, Beaumaris	830.07	''	21/09/01
Mr Donald Joseph Elks & Mrs Thelma Agnes Elks, 21 Burgess Street, Caloundra, Qld	788.90	''	''
Mr David Emmerson, 56 Abingdon Villas, London W8 6XD, Great Britain	600.31	''	09/03/01
Ms Annette Fortescue, C/- PO Box 98, North Melbourne	271.40	''	21/09/01
Ms Annette Fortescue, C/- PO Box 98, North Melbourne	224.20	''	09/03/01
Mr Hugh Douglas Fortescue & Mrs Dorothy Joyce Fortescue, ''Fortescue Family A/c'', 361 Riverton Drive, Shelley, WA	152.00	''	''
Fresnell Pty Ltd, ''Marian Flynn Super A/c'', C/- Pritchard Adams, GPO Box 5456, Sydney, NSW	154.45	''	21/09/01
Fresnell Pty Ltd, ''Marian Flynn Super A/c'', C/- Pritchard Adams, GPO Box 5456, Sydney, NSW	127.59	''	09/03/01
Mr James Furber, ''A/c Effigy International Super Fund'', PO Box 50, Woollahra, NSW	271.75	''	21/09/01
Mr James Furber, ''A/c Effigy International Super Fund'', PO Box 50, Woollahra, NSW	224.49	''	09/03/01
Mr Richard Nigel Graham Glasgow & Mrs Ulricke Ute Glasgow, 2215-27 Hutchinson Street, Surry Hills, NSW	241.39	''	21/09/01
Goodwin Enterprises Pty Limited, PO Box 86, Caringbah, NSW	135.70	''	''
Goodwin Enterprises Pty Limited, PO Box 86, Caringbah, NSW	112.10	''	09/03/01
Mr Peter Kenneth Gorst, Wickliffe	287.39	''	21/09/01
Mr Peter Kenneth Gorst, Wickliffe	237.41	''	09/03/01
Mr Peter Kenneth Gorst, RMB 459, Willaura	390.77	''	21/09/01
Mr Peter Kenneth Gorst, RMB 459, Willaura	322.81	''	09/03/01
Grant Thornton Nominees Pty Ltd, ''G. R. Ritter Super Fund A/c'', C/- Grant Thornton, GPO Box 4369, Melbourne	271.40	''	21/09/01
Grant Thornton Nominees Pty Ltd, ''G. R. Ritter Super Fund A/c'', C/- Grant Thornton, GPO Box 4369, Melbourne	224.20	''	09/03/01
Mr David Gardner Hyndman, Unit 3, 12 Monaghan Way, Karratha, WA	325.68	''	21/09/01
Mr David Gardner Hyndman, Unit 3, 12 Monaghan Way, Karratha, WA	269.04	''	09/03/01
Janatos Pty Ltd, 130 Beecroft Road, Beecroft, NSW	271.40	''	21/09/01
Janatos Pty Ltd, 130 Beecroft Road, Beecroft, NSW	224.20	''	09/03/01
Mr Martin Lennan, 128 Buchan St, Bungalow, Cairns, Qld	101.78	''	21/09/01
Ms Margaret Joan Linklater, 7 David Street, Clifton Gardens, NSW	172.50	''	''

Mr Michael Roebourne Madigan, C/- Phillips Henderson Ward, GPO Box 2419, Adelaide, SA	657.23	”	”
Mr Murray John Marks & Mrs Patricia Jeannine Marks, Broughton View, RSD Merriton, SA	241.02	”	09/03/01
Ms Trish Mayo, RMB 636, C/- Tahara Pastoral Company, Wagga, NSW	112.10	”	”
Mr John Charles Howard McAdam, 15 Risdon Drive, North Clayton	853.30	”	21/09/01
Mr John Charles Howard McAdam, 15 Risdon Drive, North Clayton	704.90	”	09/03/01
Mr James Arthur Miller & Mrs Catherine Anne Miller, 18 Barbara Street, Moorabbin	161.00	”	21/09/01
Mr Jarrod Luke Molloy, 26 Allambee Ave, Camberwell	143.75	”	”
Mr Jarrod Luke Molloy, 26 Allambee Ave, Camberwell	118.75	”	09/03/01
Murholme Resources Pty Ltd, “Macarthur Super Fund A/c”, Level 42/80 Collins Street, Melbourne	115.00	”	21/09/01
Mr Mark Murray Murton, 52 Napoleon Street, Battery Point, Tas.	138.00	”	”
Ninth Gralloch Holdings Pty Ltd, “K & B Healey S/F A/c”, 33–35 Nish Street, Echuca	168.15	”	09/03/01
Mr Finbar Declan Oleary, 80 Port Hacking Road, Sylvania, NSW	124.64	”	”
Parkside Consulting Pty Ltd, “Parkside Consult S/Fund A/c”, C/- Grant Thornton Investment, GPO Box 4369QQ, Melbourne	128.80	”	21/09/01
Parkside Consulting Pty Ltd, “Parkside Consult S/Fund A/c”, C/- Grant Thornton Investment, GPO Box 4369QQ, Melbourne	106.40	”	09/03/01
Polbasta Pty Limited, PO Box 378, Avalon Beach, NSW	2,113.01	”	21/09/01
Polbasta Pty Limited, PO Box 378, Avalon Beach, NSW	1,745.53	”	09/03/01
John Scott Stewart Richardson, PO Box 37, 917 Parnell, Auckland, New Zealand	230.00	”	21/09/01
Ricktock Pty Limited, PO Box 330, Kensington, NSW	678.50	”	”
Ricktock Pty Limited, PO Box 330, Kensington, NSW	560.50	”	09/03/01
Mr Nicholas Francis Robinson, “The Robinson Super Fund A/c”, 57 Longview Road, Balwyn North	171.00	”	”
Ms Hilda Sefton, C/- Computershare Registry Services Pty Ltd, GPO Box 2848EE, Melbourne	335.46	”	21/09/01
Ms Hilda Sefton, C/- Computershare Registry Services Pty Ltd, GPO Box 2848EE, Melbourne	277.12	”	09/03/01
Mr John Maxwell Seymour, “S W Superannuation Fund A/c”, PO Box 519, Archerfield, Qld	232.65	”	21/09/01
Mrs Dorothy Dawn Simpfendorfer, 18 Rennison Street, Beaumaris	814.20	”	”
Mrs Dorothy Dawn Simpfendorfer, 18 Rennison Street, Beaumaris	672.60	”	09/03/01
Trendsure Pty Ltd, PO Box 170, Edwardstown, SA	516.93	”	21/09/01
Trendsure Pty Ltd, PO Box 170, Edwardstown, SA	427.03	”	09/03/01
Ms Shirley Anstruther Trevenar, 5/57 Orpington Street, Ashfield, NSW	133.17	”	21/09/01

Ms Shirley Anstruther Trevenar, 5/57 Orpington Street, Ashfield, NSW	110.01	”	09/03/01
Ujamaa Nominees Pty Limited, “A/c The Mann Judd Partners Superannuation Fund”, 15 Rheola Street, West Perth, WA	287.50	”	21/09/01
Ujamaa Nominees Pty Limited, “A/c The Mann Judd Partners Superannuation Fund”, 15 Rheola Street, West Perth, WA	237.50	”	09/03/01
Wilderhope Pty Ltd & Mr John Smallman, “Wilderhope Super Fund A/c”, 106 Anglers Road, Cape Paterson	169.63	”	21/09/01
Wilderhope Pty Ltd & Mr John Smallman, “Wilderhope Super Fund A/c”, 106 Anglers Road, Cape Paterson	140.13	”	09/03/01

03118

CONTACT: ELAINE HARE, PHONE: (03) 9611 5714.

Unclaimed Moneys Act 1962

Register of Unclaimed Moneys held by the —

<i>Name of Owner on Books and Last Known Address</i>	<i>Total Amount Due to Owner</i>	<i>Description Of Unclaimed Money</i>	<i>Date when Amount first became Payable</i>
STRATEGIC POOLED DEVELOPMENT LTD			
\$			
Dr Christine Florence Butler, 201 Edgecliff Road, Woollahra, NSW	530.00	Cheque	25/06/01
Mr John Crennan, “TWR (Aust) P/L Exec S/F A/c”, C/- Holden Special Vehicles, 224 Ferntree Gully Road, Notting Hill	530.00	”	”
Mr Stephen Cross & Ms Lisa Cross, 25 Ross Crescent, Sunshine Beach, Qld	1,060.00	”	”
E. G. Enterprises Pty Ltd, PO Box 520, Paddington, NSW	258.00	”	”
Mr Travis Jay Gorlin, 5 Corben Street, Reservoir	225.25	”	”
Mr Christian Johnston, 173 Park Drive, Parkville	106.00	”	”
Kalsten Pty Ltd, PO Box 704, Indooroopilly, Qld	1,060.00	”	”
Mr Keith William Knox & Ms Anna Maree Knox, C/- Lonsdale (Prs), Box 28, Flinders Lane PO, Melbourne	530.00	”	”
Mr Gregory Koulax & Mrs Kathy Koulax, GPO Box 2217T, Melbourne	185.50	”	”
Ms Jane Lucas, 1/5 Beach Street, Merimbula, NSW	2,120.00	”	”
Mr Ronald Rafferty, 6 Korel Gardens, Swanbourne, WA	530.00	”	”
Mr Peter Russell, PO Box 719, Miranda, NSW	530.00	”	”
Mr Robin Settle, Suite 8, 200 Sydney Road, Brunswick	1,060.00	”	”
Victory Avenue Pty Ltd, 15 Midlothian St, Malvern East	159.00	”	”
Mr Sean Francis Walsh, 23/343 Riley St, Surry Hills, NSW	371.00	”	”
Wuhle Holdings Pty Limited, 2 Lockyer St, Griffith, ACT	530.00	”	”
Wuhle Holdings Pty Limited, 2 Lockyer St, Griffith, ACT	530.00	”	”

03117

CONTACT: ELAINE HARE, PHONE: (03) 9611 5714.

Unclaimed Moneys Act 1962

Register of Unclaimed Moneys held by the —

<i>Name of Owner on Books and Last Known Address</i>	<i>Total Amount Due to Owner</i>	<i>Description Of Unclaimed Money</i>	<i>Date when Amount first became Payable</i>
SWAN HILL RURAL CITY COUNCIL			
	\$		
Mr Judd Laine, C/- Kisimul Caravan Park	135.00	Cheque	28/10/99
C. & P. Stacey, PO Box 2221, Mildura	153.06	"	17/03/00
03188			
CONTACT: ERIN JENKINS, PHONE: (03) 5036 2319.			

Unclaimed Moneys Act 1962

Register of Unclaimed Moneys held by the —

<i>Name of Owner on Books and Last Known Address</i>	<i>Total Amount Due to Owner</i>	<i>Description Of Unclaimed Money</i>	<i>Date when Amount first became Payable</i>
TEMPLETON GLOBAL GROWTH FUND LIMITED			
	\$		
A. & C. A. Davey Enterprises Pty Limited, 22 Burrandong Cres, Baulkham Hills, NSW	150.00	Cheque	06/03/01
Mr Erwin Clayton & Mrs Mary Clayton, "Clayton Family A/c", 21 Cherrybrook Road, West Pennant Hills, NSW	800.00	"	28/09/01
Mr Erwin Clayton & Mrs Mary Clayton, "Clayton Family A/c", 21 Cherrybrook Road, West Pennant Hills, NSW	500.00	"	16/03/01
Mr Ian Dawson, "Dawson Family Settlement", 49 Gunther Parade, Pasadena, SA	200.00	"	28/09/01
Mr Raymond Albert Lewis, 61 Anglesey Avenue, St Georges, SA	640.00	"	"
William Henry McCausland, 3 Shipway House, Bolton Road, Chiswick, London W4 3TE, United Kingdom	160.00	"	"
Miss Ann Elizabeth Miller & Mr Michael John Walter, C/- Mr P. J. Horsburgh, Pricewaterhouse Coopers, GPO Box 1331L, Melbourne	625.00	"	16/03/01
Mr John Richard Morgan, "The John Morgan Super A/c", C/- Henson & Co, 91 Halifax Street, Adelaide, SA	400.00	"	"
Mr Jeffrey Pohl, C/- Private Investment Mgt, GPO Box 2613, Sydney, NSW	320.00	"	28/09/01

Estate Late John Peter Powell, C/- Tragear & Associates Pty, PO Box 63, Sandringham	400.00	”	”
Mr Andy Spoel & Mr Derk Spoel, 4 Yellowbox Close, Caves Beach, NSW	350.00	”	16/03/01
Mr Chetan Dev Tayal, PO Box 346, Adelaide, SA 03121	250.00	”	”

CONTACT: ELAINE HARE, PHONE: (03) 9611 5714.

Unclaimed Moneys Act 1962

Register of Unclaimed Moneys held by the —

<i>Name of Owner on Books and Last Known Address</i>	<i>Total Amount Due to Owner</i>	<i>Description Of Unclaimed Money</i>	<i>Date when Amount first became Payable</i>
THE TEXT MEDIA GROUP LIMITED			
	\$		
Ms Georgina Brujic, 11/36–40 Muston St, Mosman, NSW 03126	102.00	Cheque	01/10/01

CONTACT: ELAINE HARE, PHONE: (03) 9611 5714.

Unclaimed Moneys Act 1962

Register of Unclaimed Moneys held by the —

<i>Name of Owner on Books and Last Known Address</i>	<i>Total Amount Due to Owner</i>	<i>Description Of Unclaimed Money</i>	<i>Date when Amount first became Payable</i>
TICOR LIMITED			
	\$		
Gordon Eric Bowen, 13 Madeleine Street, Doncaster	105.00	Cheque	19/10/01
David Robert Challis, PO Box 323, Byron Bay, NSW	158.05	”	20/04/01
David Robert Challis, PO Box 323, Byron Bay, NSW	126.44	”	19/10/01
Mr Martin Charles Doull, 9 Windermere Street, Ballarat	200.00	”	”
G. G. & T. M. Investments Pty Ltd, 20 Third Avenue, Lane Cove, NSW	200.00	”	”
John Terrence Ivimey, 41/300A Burns Bay Road, Lane Cove, NSW	262.50	”	20/04/01
John Terrence Ivimey, 41/300A Burns Bay Road, Lane Cove, NSW	210.00	”	19/10/01
Mr Dai Kyu Kim, 272/272 Victoria Avenue, Chatswood, NSW	1,648.00	”	”
Mrs Josephine Eve Lipman, GPO Box 249, Adelaide, SA	101.90	”	20/04/01
Mr Rex John Lipman, GPO Box 249, Adelaide, SA	164.50	”	”

Dr Andrew Creighton Lomas, PO Box 1244, Toowoomba, Qld	500.00	”	”
Dr Andrew Creighton Lomas, PO Box 1244, Toowoomba, Qld	400.00	”	19/10/01
Larry Vladimir Machalik, 34 Nicholson Crescent, Bell Park	131.25	”	20/04/01
Larry Vladimir Machalik, 34 Nicholson Crescent, Bell Park	105.00	”	19/10/01
Ron Monson, 21 Locke Crescent, East Fremantle, WA	115.00	”	20/04/01
William Bernard Needham & Betty Patricia Needham, 18 Copenhagen Street, Tiaro, Qld	100.00	”	”
R. G. M. Consultants Pty Ltd, “RGM Superannuation Fund A/c”, 7/45 Preston Point Road, East Fremantle, WA	226.50	”	”
Mr Bruce Edwin Stephenson, Lot C, Peach Tree Road, Megalong Valley, NSW	122.00	”	”
Mrs Penelope Treleaven, PO Box 2932, Broome, WA	640.00	”	19/10/01
Mr Antony Gordon Wilmshire & Ms Veronica Snook, 11 Longroyd St, Mount Lawley, WA	111.00	”	20/04/01
Mr Neil Malcolm Winkelmann, 18 Richard Austen Crescent, Middlemount, Qld	150.00	”	”
Mr Neil Malcolm Winkelmann, 18 Richard Austen Crescent, Middlemount, Qld	120.00	”	19/10/01

03122

CONTACT: ELAINE HARE, PHONE: (03) 9611 5714.

Unclaimed Moneys Act 1962

Register of Unclaimed Moneys held by the —

<i>Name of Owner on Books and Last Known Address</i>	<i>Total Amount Due to Owner</i>	<i>Description Of Unclaimed Money</i>	<i>Date when Amount first became Payable</i>
TOLL HOLDINGS LIMITED			
	\$		
Anthony C. Cumming Pty Ltd, C/- Tower Trust Limited, GPO Box 546, Adelaide, SA	245.10	Cheque	30/03/01
Mr David Nil Braatvedt & Mrs Deborah Braatvedt, “Braatvedt No 1 Super A/c”, PO Box 545, Alderley, Qld	462.00	”	28/09/01
Dr Glen Michael Brown & Dr Charla Cristal Griffy-Brown, 13211 Admiral Avenue, Unit A, Marina Del Rey, CA 90292, USA	416.60	”	”
Mrs Estela Curtis, 49 Underwood Rd, Homebush, NSW	150.00	”	30/03/01
Mr Ivor Arthur Davies, C/- G. Principe, PO Box 543, Milsons Point, NSW	462.00	”	28/09/01
Ms Elaine Dellow, 18 Pile Street, N. Bardwell Park, NSW	540.00	”	”
Ms Elaine Dellow, 18 Pile Street, N. Bardwell Park, NSW	450.00	”	30/03/01
Mr Allan William Evans, 26 Cahill Street, Dandenong	242.00	”	”

Mr Neville Murray Hentschel & Mrs Pamela Florence Hentschel, 12 Tarzali Street, Algester, Qld	600.00	”	”
Ms Roslyn A. Lincoln, 4 Bimbimbi Avenue, Prospect, Tas. Nemrut Pty Ltd, “Nicholson Super Fund A/c”, 13 Harold Avenue, Glen Iris	54.00	”	28/09/01
Mr Paul Francis Nicholson, “Freight People A/c”, PO Box 615, Hawthorn	135.00	”	”
Mr Neil Sheppard, Whitehead	375.00	”	30/03/01
Mr Neil Sheppard, Whitehead	231.00	”	28/09/01
Supreme Plastic Moulder Pty Ltd, “Directors Super Fund A/c”, 13 Clare Street, Bayswater	182.00	”	30/03/01
Supreme Plastic Moulder Pty Ltd, “Directors Super Fund A/c”, 13 Clare Street, Bayswater	360.00	”	28/09/01
Mr Barry Wayne Thomson, “Derriwee”, Gunnedah, NSW	300.00	”	30/03/01
	105.40	”	28/09/01

03133

CONTACT: ELAINE HARE, PHONE: (03) 9611 5714.

Unclaimed Moneys Act 1962

Register of Unclaimed Moneys held by the —

<i>Name of Owner on Books and Last Known Address</i>	<i>Total Amount Due to Owner</i>	<i>Description Of Unclaimed Money</i>	<i>Date when first became Payable</i>
TREASURY GROUP LTD			
	\$		
Soldon Investments Pty Ltd, 2 Meryl Street, Armadale	452.50	Cheque	01/10/01
Soldon Investments Pty Ltd, 2 Meryl Street, Armadale	502.50	”	23/03/01

03123

CONTACT: ELAINE HARE, PHONE: (03) 9611 5714.

Unclaimed Moneys Act 1962

Register of Unclaimed Moneys held by the —

<i>Name of Owner on Books and Last Known Address</i>	<i>Total Amount Due to Owner</i>	<i>Description Of Unclaimed Money</i>	<i>Date when Amount became Payable</i>
TROY RESOURCES NL			
	\$		
Mr Donald Ian Anderso, 3 Ingleton Place, Esperance, WA	103.86	Cheque	15/10/01
Mr Phillip Bryan Anderson, 34 Monash Ave, Nedlands, WA	103.86	"	"
Ben Richard Pty Ltd, 12 Zenobia Street, Kelmscott, WA	103.86	"	"
Mrs Elaine Armgard Cassidy, 8/18 Flinton Street, Paddington, NSW	225.00	"	"
Rex Castle, PO Box 5903, Auckland, New Zealand	360.00	"	"
Mr Henry Frank Cooke, 29 Davies Road, Claremont, WA	180.00	"	"
Ms Louise Cooney, 297 New Street, Brighton	103.86	"	"
Dalmist Pty Ltd, 34 Stirling Road, Claremont, WA	103.86	"	"
Delin Pty Ltd, 9 Catalina Cove, Maylands, WA	155.79	"	"
Mrs Janine Esmae Edwards, 96 Gibraltar Drive, Isle of Capri, Qld	135.00	"	"
Denise Zoe Escott, 462 Dandenong Road, North Caulfield	180.00	"	"
Goldfield Holdings Pty Ltd, 3 Gunbower Road, Mount Pleasant, WA	103.86	"	"
Elisabeth Grieder, C/- Sydney International Travel Services, 24A Pitt Street, Sydney, NSW	225.00	"	"
Halfaxe Pty Ltd, PO Box 192, Eudlo, Qld	114.26	"	"
Mr Graeme Hall, "N. W. Hall Super Fund A/c", PO Box 357, Mildura	450.00	"	"
Mr James Harris, Floor 2, 85 Coventry St, South Melbourne	234.00	"	"
Mr Kenneth Michael Hooper & Mrs Joan Patricia Hooper, PO Box 707, Dunsborough, WA	810.00	"	"
Ji Yong Jiang, 24 Delphine Ave, Dianella, WA	138.51	"	"
Mr Ji Yong Jiang, 477(A) Lennard Street, Dianella, WA	207.77	"	"
Ms Terry Ann Knight, 7 Columbia Close, Mandurah, WA	238.91	"	"
Mr Francis George Laming & Mrs Patricia May Laming, 30 Birrine Gardens, High Wycombe, WA	114.26	"	"
Mr Mark James Llleuellyn, 4 Pandanus Street, Blackwater, Qld	207.77	"	"
Suellen Mary Mansour, 14 Kinane Street, Brighton	135.00	"	"
Mrs Kaye Martin, 581 Fisher Street, Broken Hill, NSW	103.86	"	"
Mr Colin Robert McGregor & Mrs June Lorraine McGregor, 72 Wendouree Road, Wilson, WA	103.86	"	"
Mr David John McKnight, 20 Cressbrook Way, Carine, WA	112.50	"	"
David Nathan, 4/7 London Street, Ponsonby, Auckland, New Zealand	180.00	"	"
Anthony Natoli, 11 Montpellier Drive, Avondale Heights	112.50	"	"

Mr Steven Patrick, 12 Spit Road, Spit Junction, NSW	180.00	”	”
Perri Developments Pty Ltd, “Vince Perri Super Fund A/c”, Unit 1, 32 Ruby Street, Balwyn	110.79	”	”
P. O. Nominees Pty Ltd, 66 Urquhart Street, Hawthorn	900.00	”	”
Prodirae Pty Ltd, PO Box 1285, Osborne Park Business Centre, Osborne Park, WA	207.77	”	”
Mr Indiran Anton Rajadurai, 63A Wichmann Road, Attadale, WA	138.51	”	”
Regi Pty Ltd, “J. H. & V. A. Lee Super Fund A/c”, PO Box 686, Balcatta, WA	259.70	”	”
Israel Slonim, 569 Inkerman Road, Caulfield	360.00	”	”
Mr Errol Edgar Smith, 20 Pont Road, Leadgate Consett County, Durham DH8 6HE, UK	176.58	”	”
Somersby Management and Investment Pty Ltd, 29 Kintore Street, Wahroonga, NSW	207.77	”	”
Soso Pty Ltd, C/- Gillis Delaney Brown, 75-85 Elizabeth Street, Sydney, NSW	131.90	”	”
Neil Kevin Stewart, “The Stewart Super Fund A/c”, Attn: Mr Kevin Stewart, 1320 Hay Street, West Perth, WA	145.44	”	”
Gordon Robert Timm, C/- Access Brokerage Ltd, PO Box 1293, Wellington, New Zealand	175.55	”	”
Uniq Consulting Pty Limited, PO Box N3, Grosvenor Place, NSW	103.86	”	”
Mr Benjamin Christopher Walkley & Mr Gregory James Duncan, PO Box 519, Willunga, SA	103.86	”	”
Miss Kerrylye Warwick, 31 Orient St, Batemans Bay, NSW	112.50	”	”
Cecilia Wee, 2 Ewart Park 1027, Singapore	138.51	”	”

03125

CONTACT: ELAINE HARE, PHONE: (03) 9611 5714.

Unclaimed Moneys Act 1962

Register of Unclaimed Moneys held by the —

<i>Name of Owner on Books and Last Known Address</i>	<i>Total Amount Due to Owner</i>	<i>Description Of Unclaimed Money</i>	<i>Date when Amount first became Payable</i>
TRUST COMPANY OF AUSTRALIA LIMITED			
\$			
John P. Armstrong, PO Box 890, Bondi Junction, NSW	1,188.00	Cheque	18/06/01
Mrs Joyce Esther Elsie Barton, PO Box 484, Roseville, NSW	220.00	”	”
Reginald Bernard Barton, PO Box 484, Roseville, NSW	2,002.00	”	”
Clarence Royce Bateman, 23 Boyce Avenue, Wyong, NSW	330.00	”	”
Ian D. Bell, PO Box 151, Dural, NSW	1,241.46	”	”

Mr Terence Frederick Brown & Mrs Carmel Marie Brown, Unit 9, 3 Warne Terrace, Caloundra, Qld	110.00	''	''
Mr Thomas Campbell Chalmer, 161 Pelham Street, Tenterfield, NSW	286.00	''	''
Clan Investments Pty Ltd, PO Box 226, Spit Junction, NSW	2,266.00	''	''
Mrs Mary Elizabeth Clements, 24 Dartnell Street, Gowrie, ACT	2,915.00	''	''
Cochrane Enterprises Pty Ltd, 40 Henry Street, Cook, ACT	989.12	''	''
Barbara Joan Conaghan, 109 Rundle Street, Rockhampton, Qld	154.00	''	''
Mrs Caroline M. Crawford, C/- Police Station, Whittlesea	117.26	''	07/05/01
Mrs Caroline M. Crawford, C/- Police Station, Whittlesea	411.70	''	18/06/01
Mrs Caroline M. Crawford, C/- Police Station, Whittlesea	119.20	''	15/11/01
Mrs Christine Cribb, 11 Nabiac Place, Westleigh, NSW	197.56	''	18/06/01
Equestrian Publishing Pty Ltd, "Provident Fund A/c", PO Box 551, Dee Why, NSW	440.00	''	''
Mr Angus David Eric Finney, 19 Monterey Street, St Ives, NSW	374.00	''	''
Mrs Judy Ann Fitzgerald, PO Box 3, Peakhurst, NSW	198.00	''	''
Ms Rosanne Green, 27 Herbert Place, Albert Park	121.00	''	''
Katherine Holmes, 36 Lumsdaine Street, Picton, NSW	790.90	''	''
Miss Elizabeth Marie Jameson, 2/93 Enoggera Terrace, Red Hill, Qld	4,550.20	''	''
Brenda E. Kilby, 95 Kissing Point Road, Dundas, NSW	329.12	''	''
Estate Late Ian Osborn Lawrence & Mrs Raelene Susan Lawrence, 6 Balcara Avenue, Carseldine, Qld	198.72	''	07/05/01
Estate Late Ian Osborn Lawrence & Mrs Raelene Susan Lawrence, 6 Balcara Avenue, Carseldine, Qld	732.20	''	18/06/01
Estate Late Ian Osborn Lawrence & Mrs Raelene Susan Lawrence, 6 Balcara Avenue, Carseldine, Qld	212.00	''	15/11/01
Mrs Raelene Susan Lawrence, 6 Balcara Avenue, Carseldine, Qld	174.80	''	18/06/01
Mr Brian Norman Lees, 13 Amiens Road, Clontarf, NSW	990.00	''	''
Est Late Max Hilton Lowery, C/- Perpetual Tasmania Funds Management, GPO Box 227C, Hobart, Tas.	770.00	''	''
Thomas Bass MacIndoe, C/- Permanent Trustee Co Ltd, 23-25 O'Connell Street, Sydney, NSW	550.00	''	''
Mr Claude Anthony Martin & Mrs Joan Marion Martin, 11 Lowther Park Avenue, Turrumurra, NSW	330.00	''	''
Estate Late Frank William Powell May, C/- Permanent, GPO Box 4270, Sydney, NSW	246.62	''	''
Mr Frederick Mayer & Mr Samuel Paul Mayer, 18-21 Chalmers Cres, Mascot, NSW	220.00	''	''
Miss Katherine Anne McNamara, "K. A. McNamara BM0162 A/c", GPO Box 4270, Sydney, NSW	302.50	''	''
Est Mrs Patricia Mary Minter, 11A/21 Thornton Street, Darling Point, NSW	5,280.00	''	''

Estate of The Late Doreen May Morgan, C/- Maurice Freidman & Company Solicitors, DX 318, Sydney, NSW	1,518.44	”	”
Mr John Robert McKenzie Nave & Mr Peter Dean Nave, 11 Monomeath Avenue, Canterbury Neco Pty Ltd, “Neco Pty Ltd Ad5730 A/c”, GPO Box 4270, Sydney, NSW	528.00	”	”
Mr Peter Howard Nickell, Unit 2, 8-12 Weir Street, Balwyn Noel Whittaker Holdings Pty Ltd, “Whittaker Family Super A/c”, 40 Aaron Avenue, Hawthorne, Qld	3,178.12	”	”
Keith O’Connell, 11 Ogilvie Street, Terrigal, NSW	1,089.00	”	”
Ms Ruby Gertrude Oldham, 11 Saladin Street, Swanbourne, WA	149.20	”	07/05/01
Permanent Trustee Company Ltd, Executors of The Late Francis Ralph Stephen Dawes, GPO Box 4270, Sydney, NSW	880.00	”	18/06/01
Mr John Connelly Potts, Unit 348, John Paul Village, 15 The Avenue, Heathcote, NSW	1,485.00	”	”
Mr Julian Reynolds, 2 Alton Street, Woollahra, NSW	1,848.44	”	”
Mr Hans Rosenthal, 15 Clanalpine Street, Mosman, NSW	110.00	”	”
Mr Hans Rosenthal, 15 Clanalpine Street, Mosman, NSW	1,320.00	”	”
Mr John Stratford Sheldon, 1A Dalwood Avenue, Seaforth, NSW	756.14	”	”
Mr John Brian Lerpiniere Watt, “J. B. L. Watt Ac 9199 A/c”, GPO Box 4270, Sydney, NSW	660.00	”	”
Samuel Robert Whitney, PO Box 931, Cooma, NSW	358.60	”	”
	2,310.00	”	”
	742.50	”	”

03124

CONTACT: ELAINE HARE, PHONE: (03) 9611 5714.

Unclaimed Moneys Act 1962

Register of Unclaimed Moneys held by the —

<i>Name of Owner on Books and Last Known Address</i>	<i>Total Amount Due to Owner</i>	<i>Description Of Unclaimed Money</i>	<i>Date when Amount first became Payable</i>
UNITED ENERGY LIMITED			
	\$		
Addis Pty Ltd, “Addis Super Fund A/c”, PO Box 4006, Langwarrin	156.75	Cheque	10/09/01
Addis Pty Ltd, “Addis Super Fund A/c”, PO Box 4006, Langwarrin	171.00	”	13/03/01
Ms Jennifer Ann Allison, 58 Renny Street, Paddington, NSW	490.79	”	10/09/01
Mr Eric Stewart Anderson, 4 Newbury Ct, Carrum Downs	156.75	”	”
Mr Eric Stewart Anderson, 4 Newbury Ct, Carrum Downs	171.00	”	13/03/01
Ms Christine Mae Atkinson & Mr Scott Alan Atkinson, “Atkinson Family S/Fund A/c”, C/- Mr T. Breward, PO Box 1003, Launceston, Tas.	247.50	”	10/09/01

Bannerhigh Pty Ltd, PO Box 645, New Farm, Qld	247.50	''	''
Mr Gregory Douglas Barnwell, 75 Manor Road, Hornsby, NSW	143.55	''	''
Mr Sam Richard Bayley, PO Box 253, Sandy Bay, Tas.	412.50	''	''
Ali Benami, 20/22–24 Whitehorse Road, Blackburn	108.00	''	13/03/01
Esther Benjamin, 2 Hillside Ave, Glen Iris	108.00	''	''
Mr Chris Birmingham, PO Box 51, Dwellingup, WA	113.85	''	10/09/01
Mrs Susan Veronica Blakeney, 44 The Outlook, Glen Waverley	225.00	''	13/03/01
Bmj Nominees Pty Ltd, 51 Hopetoun Road, Toorak	108.00	''	''
Barry Bowler & Roger Kilby, 9 Adelaide Street, Armadale	108.00	''	''
Don Bowman, 201 Awa Road, Kumeu RD1, Auckland 1250, New Zealand	118.39	''	10/09/01
Est Mr Phillip Aaron Brygel, "No 2 Account", C/- Mr Ashley Brygel, 19 Ward Avenue, Caulfield North	180.00	''	13/03/01
Burcol Pty Ltd, "Super Fund A/c", 35 Hawthorn Road, Caulfield North	117.00	''	''
Mr Warren Burns & Mr Franko Bucco, 9 The Rialto West, Malvern East	180.00	''	''
Ms Emma Louise Butler, 6B Matheson Road, Forest Hill	108.00	''	''
Robert Allen Cane, "Ultimate Products S/F A/c", 45 Douglas Street, Blackburn North	1148.50	''	10/09/01
Robert Allen Cane, "Ultimate Products S/F A/c", 45 Douglas Street, Blackburn North	162.00	''	13/03/01
C. G. Ryan Pty Ltd, "C. Ryan Super Fund A/c", PO Box 112, Mackay, Qld	198.00	''	''
Mr Benito Chaippazzo, 40 Himalaya Crescent, Seven Hills, NSW	107.25	''	10/09/01
Mr Geoffrey William Chambers, "Super Fund A/c", PO Box 108, Cheltenham	330.00	''	''
Dr David Wilton Chandler, 13 Pages Road, St Marys, NSW	115.50	''	''
Dennis Lide Chang, Unit 6, 176 Ayr Street, Doncaster	115.50	''	''
Dennis Lide Chang, Unit 6, 176 Ayr Street, Doncaster	126.00	''	13/03/01
Mr Alan John Linnett Chapman, "4kiwis Ltd A/c", 5 Pouwhare Street, Whakatane, Bop 3080, New Zealand	288.75	''	10/09/01
Mr Roderick James Chisholm & Mrs Susan Patricia Chisholm, "Parker Chisholm Super A/c", C/- Supa Funds Management, PO Box 1300, Toowong, Qld	247.50	''	''
Mr Fok Yen Chung, 4 Artemis Court, Lower Templestowe	108.00	''	13/03/01
Elma Cole Tillabudgery, Lot 1, Stanleys Rd, Merricks North	247.50	''	10/09/01
Comans Superannuation Pty Ltd. Apt B, 4 Whaling Road, North Sydney, NSW	536.25	''	''
Comans Superannuation Pty Ltd. Apt B, 4 Whaling Road, North Sydney, NSW	585.00	''	13/03/01
Mr David Coubrough, 95 9th Avenue, Highlands North, Johannesburg 2192, South Africa	280.35	''	''
Alma Coughlan, 7 Juliana Street, Bentleigh East	108.00	''	''
Mr Simeon Cran, PO Box 5706, West End, Qld	108.00	''	''
Mr Stuart Ian Cruickshank & Mrs Cary Melville Cruickshank, PO Box 22, Rolleston, Christchurch, New Zealand	165.00	''	10/09/01
Mr Anthony Thomas Dage, 3 Elliot Close, Donvale	265.65	''	''

Mr Anthony Thomas Dage, 3 Elliot Close, Donval	289.80	''	13/03/01
Scott C. Davies, "Mersco P L, Atf Scd S/F A/c", 71 Stanhope Street, Malvern	108.00	''	''
Andrew Davis, 61 Claremont Avenue, Malvern	108.00	''	''
Mr Damian Dobbin, 330 Alma Road, Caulfield North	270.19	''	10/09/01
Mr Damian Dobbin, 330 Alma Road, Caulfield North	294.75	''	13/03/01
Rod Doddridge, 181 Wickham Road, Moorabbin	115.50	''	10/09/01
Rod Doddridge, 181 Wickham Road, Moorabbin	126.00	''	13/03/01
Peter J. Douge, 18 Riverside Ave, Balwyn North	108.00	''	''
Mr Andrew Gerard Dowling, C/- CSFBAE Private Limited, GPO Box 1035, Brisbane, Qld	247.50	''	10/09/01
Stephen John Earp & Catherine Marie Coady, 10 Quat Quatta Avenue, Elsternwick	108.00	''	13/03/01
Miss Frances Lillian Edney, 21 Oak Street, Bentleigh	247.50	''	10/09/01
Clem Engelkamp, "Academy Tower P/L S/F A/c", 13 Melosa Avenue, Brighton East	108.00	''	13/03/01
Mr William Eyre & Ms Sally Miller, 117 Mitchell Street, Northcote	196.35	''	10/09/01
Mr Allan Bruce Fisk, 49 Gordon Street, Clontarf, NSW	412.50	''	''
Aaron Patrick Flanagan, 32 Pine Street, Brighton East	148.50	''	''
Aaron Patrick Flanagan, 32 Pine Street, Brighton East	162.00	''	13/03/01
Mavis Elderson Foley, 75 Marriage Road, Brighton East	247.50	''	10/09/01
Judith A. Foreman, 19 Augusta Street, Mount Martha	108.00	''	13/03/01
Mr Anthony Garth Fowler, 16 Yarra Bank Court, Abbotsford	438.95	''	''
Mr Anthony Garth Fowler, 16 Yarra Bank Court, Abbotsford	484.07	''	10/09/01
Mr Steven Brian Fowler, 17 Gamma Crescent, Panorama, SA	165.00	''	''
Rosemary Ann Foxcroft, 70A Beaconsfield Parade, Albert Park	108.00	''	13/03/01
Peter Franklyn, 5 Cressy Street, Malvern	108.00	''	''
Mr William Geoffrey Freeman, 7/20 Canal Avenue, Runaway Bay, Qld	231.00	''	10/09/01
Ralph D. Garbers, "Garbers Super Fund A/c", 126 Overport Road, Frankston	108.00	''	13/03/01
Gaw Nominees Pty Ltd, 3/21 Anderson Street, Caulfield	115.50	''	10/09/01
Gaw Nominees Pty Ltd, 3/21 Anderson Street, Caulfield	126.00	''	13/03/01
Julius P. Gedey, Floor 4, 126-128 Russell Street, Melbourne	108.00	''	''
Gita Investments Pty Ltd, 2/111 Collins Street, Melbourne	165.00	''	10/09/01
Gita Investments Pty Ltd, 2/111 Collins Street, Melbourne	180.00	''	13/03/01
Mr Peter Saffer Goldberg, 33 Venus Street, Caulfield South	108.00	''	''
Antonio Golotta, Shop 5, 319 Clayton Road, Clayton	108.00	''	''
Gourocke Holdings Pty Ltd, Level 4, 15 Castlereagh Street, Sydney, NSW	330.00	''	10/09/01
Graham Jose Spares Pty Ltd, "Graham Jose Spares S/F A/c", 20 York St, Bentleigh East	354.75	''	''
Ms Laurel Jane Grant, 29A Johnston Way, Padbury, WA	103.13	''	''
Ms Laurel Jane Grant, 29A Johnston Way, Padbury, WA	112.50	''	13/03/01
Mr Hugo Robert Graves, 63 Liddiard Street, Hawthorn	165.00	''	10/09/01
Mr Hugo Robert Graves, 63 Liddiard Street, Hawthorn	180.00	''	13/03/01
Mr Martin Greville Grogan & Mrs Helen Margaret Grogan, 1 Balaka Avenue, Aspendale	173.25	''	10/09/01
Mr Martin Greville Grogan & Mrs Helen Margaret Grogan, 1 Balaka Avenue, Aspendale	189.00	''	13/03/01

Mr Charles Edward Gruber & Miss Josie Carin Gruber, "Gruber Family S/F A/c", 23 Mulubinda Parade, Corlette, NSW	123.75	"	10/09/01
Miss Josie Carin Gruber, "Gruber Family S/F A/c", 23 Mulubinda Parade, Corlette, NSW	135.00	"	13/03/01
Mrs Patricia Alice Haddleton, C/- KPMG, GPO Box 223, Brisbane, Qld	825.00	"	10/09/01
Mr Paul Derek Heward & Mrs Debra Lynn Heward, Unit 24, 42 Charlick Court, Adelaide, SA	225.00	"	13/03/01
Keith Hewitt, 12 Nardoo Court, Clayton South	216.00	"	"
Mr John Keith Howes, PO Box 187, Indooroopilly, Qld	247.50	"	10/09/01
Tony Huntley, 56 St Georges Road, Toorak	126.00	"	13/03/01
Ms Irena Jaskula, "I. J. Family A/c", PO Box 76, Deepdene	148.50	"	10/09/01
Ms Irena Jaskula, "I. J. Family A/c", PO Box 76, Deepdene	162.00	"	13/03/01
Jennifer Holdings Pty Ltd, "Brian Pallot Super Fund A/c", 57B Canning Beach Road, Applecross, WA	247.50	"	10/09/01
J. G. Guest & Sons, PO Box 210, Oakleigh	148.50	"	"
Yuan Hao Jia, 1/17-19 Hobart Road, Murrumbeena	108.00	"	13/03/01
Maria Johnson, PO Box 14, 710 Panmure, Auckland, New Zealand	108.00	"	"
Mr Mark Johnson, C/- Macquarie Bank Limited, Level 9, 1 Martin Place, Sydney, NSW	828.00	"	"
Kalman Katz Lido Chambers, Suite 5, 223 Balaclava Road, Caulfield North	363.00	"	10/09/01
John A. Kay, 3 Grassmere Road, Langwarrin	115.50	"	"
Mr Francis Keegan, 49 Hancock Avenue, Campbelltown, SA	165.00	"	"
Mrs Jean Keegan, 49 Hancock Avenue, Campbelltown, SA	165.00	"	"
Mr Pak Chung Keung, Flat 8, 20/F Block C, Sun Kwai, 151-161 Tai Wo Hau Road, Kwai Chung, Hong Kong	108.00	"	13/03/01
Edward Lee, 46 Fewster Drive, Wantirna South	108.00	"	"
Ms Hsiao Li Lee, 139/12 Commodore Drive, Paradise Waters, Qld	338.25	"	10/09/01
Ms Hsiao Li Lee, 139/12 Commodore Drive, Paradise Waters, Qld	369.00	"	13/03/01
Herb G. Lesser, 13 Strickland Drive, Glen Waverley	206.25	"	10/09/01
Herb G. Lesser, 13 Strickland Drive, Glen Waverley	225.00	"	13/03/01
Mr Barry Simon Levy, "House of Stitches S/F A/c", 70 Halifax Street, Brighton	115.50	"	10/09/01
Mr Barry Simon Levy, "House of Stitches S/F A/c", 70 Halifax Street, Brighton	126.00	"	13/03/01
Manfred Levy, 39 Balaclava Road, Balaclava	148.50	"	10/09/01
Donna L. Li, Unit 4, 1021 Dandenong Road, Malvern East	108.00	"	13/03/01
Mr Guohua Liang, 7/96 Dover Street, Flemington	222.75	"	10/09/01
Limbra Ten Pty Ltd, "J. D. McLennan Super Fund A/c", C/- Kerr Financial Services, Level 2, 423 Bourke Street, Melbourne	412.50	"	"
Limbra Ten Pty Ltd, "J. D. McLennan Super Fund A/c", C/- Kerr Financial Services, Level 2, 423 Bourke Street, Melbourne	450.00	"	13/03/01
Linjen Pty Ltd, "Staples Family A/c", 103 Normanby Road, East Kew	107.25	"	10/09/01

Linjen Pty Ltd, "Staples Family A/c", 103 Normanby Road, East Kew	117.00	"	13/03/01
Mr Douglas Link & Mrs Jann Link, 25 Marina Road, Mentone	612.00	"	"
Mr Man Waai Loe & Mrs Doreen Loe, 26 Petalnina Cres, Wantirna	108.00	"	"
Chi Hong Ly, 39 St James Avenue, Springvale	108.00	"	"
Mr Brendan Lyons, 11 Nottingham Street, Prahran	206.25	"	10/09/01
Mr Brendan Lyons, 11 Nottingham Street, Prahran	225.00	"	13/03/01
The Lyonville Group Pty Ltd, Post Office Box 1048, Altona Meadows	371.25	"	10/09/01
The Lyonville Group Pty Ltd, Post Office Box 1048, Altona Meadows	405.00	"	13/03/01
The Lyonville Group Pty Ltd, 53 Lady Nelson Crescent, Altona Meadows	742.50	"	10/09/01
The Lyonville Group Pty Ltd, 53 Lady Nelson Crescent, Altona Meadows	810.00	"	13/03/01
Mr John Stephen Maddison, 4/168 Poath Road, Hughesdale	107.25	"	10/09/01
Mr John Stephen Maddison, 4/168 Poath Road, Hughesdale	117.00	"	13/03/01
Main Beach Pty Ltd, "Considine Super Fund A/c", 978 Whitehorse Rd, Box Hill	108.00	"	"
Mr Winston James Marsh, PO Box 675, Wellesley Street Post Office, Auckland, New Zealand	222.75	"	10/09/01
Mr Winston James Marsh, PO Box 675, Wellesley Street Post Office, Auckland, New Zealand	243.00	"	13/03/01
Leslie Matheson, 5 Annette Place, Templestowe	115.50	"	10/09/01
Mr James Patrick Matthews, 50 Hatfield Street, Blakehurst, NSW	412.50	"	"
Mrs Dorothy Marie McClelland, 70 Clarke Drive, Gladstone Park	181.50	"	"
Mr Robert John McClelland, 70 Clarke Dve, Gladstone Park	181.50	"	"
Mr Craig Robert McDonald, 304 Pound Rd, Narre Warren	330.00	"	"
Mr Craig Robert McDonald, 304 Pound Rd, Narre Warren	360.00	"	13/03/01
Mr Glenn Darryl McDowall & Ms Sara Louise Clowes, "Garam Super Fund A/c", 6 Narran Place, Swan View, WA	270.00	"	"
Andrew Meckiff, 12 Cedric Street, Parkdale	108.00	"	"
Mr William Stuart Meldrum & Mrs Veronica Elizabeth Meldrum, Level 8/150 Queen Street, Melbourne	180.00	"	"
Mr William Stuart Meldrum & Mrs Meriedie Tonia Graham, C/- W. Stuart Meldrum, Level 8, 150 Queen St, Melbourne	270.00	"	"
Jim Stanley Morris, 361A Mitcham Road, Mitcham	115.50	"	10/09/01
Michelle Ann Morrison, 6 Wallace Road, Burwood	108.00	"	13/03/01
Darren John Mountain, 16 Banks Street, McCrae	108.00	"	"
Chary Mudumbi, 2 Tova Court, Wantirna South	108.00	"	"
Mr Christopher Robert Murphy, 53 Lady Nelson Crescent, Altona Meadows	726.00	"	10/09/01
Mr Christopher Robert Murphy, 53 Lady Nelson Crescent, Altona Meadows	792.00	"	13/03/01
Mr Christopher Robert Murphy, RMB 279, Trentham	841.50	"	10/09/01
Mr Christopher Robert Murphy, RMB 279, Trentham	918.00	"	13/03/01
Mr Christopher Robert Murphy, RMB 279, Trentham	1,316.86	"	"
Mr Christopher Robert Murphy, RMB 279, Trentham	1,452.20	"	10/09/01

Neonwich Pty Ltd, Dockside Hotel 703, 8 Ferry Street, Kangaroo Point, Qld	165.00	''	''
Mr Barry Paul Ney & Mrs Sylvia Joan Ney, "B. P. & S. J. Ney Super Fund A/c", 3 Sharif Street, McDowall, Qld	165.00	''	''
Mr Patrick Kevin Over, 2 Yarra Braes Road, Eltham	180.00	''	13/03/01
Mr David Alastair Owen, 330/525 Songbok Dang Songbok Ku, Seoul 136020, Korea	742.50	''	10/09/01
Mr David Alastair Owen, 330/525 Songbok Dang Songbok Ku, Seoul 136020, Korea	810.00	''	13/03/01
Peter William Owen & Glenise Joy Owen, PO Box 267, Stawell	214.50	''	10/09/01
Peter William Owen & Glenise Joy Owen, PO Box 267, Stawell	234.00	''	13/03/01
Mr Neil John Park, PO Box 346, Niddrie	126.00	''	''
William James Storrer Parsons, John Duncan Robert Parsons, RD4, New Plymouth, NZ	202.13	''	10/09/01
Mrs Joanne Margaret Rose Pearson, 7 Ti-Tree Avenue, Carrum	219.60	''	13/03/01
Mrs Joanne Margaret Rose Pearson, 7 Ti-Tree Avenue, Carrum	438.95	''	''
Dusko Pejnovic & Alison Laura Pejnovic, 38 Nirvana Avenue, Malvern East	115.50	''	10/09/01
Jack Piekarski, Unit 1, 62 Sycamore St, Caulfield South	108.00	''	13/03/01
Mr Garth Lawrence Price & Ms Kathryn Horadam, "The Price Horadam S/F A/c", 7 Adamson St, Brighton	117.00	''	''
Queenscliff Nursing Home Pty Ltd, PO Box 96, Brighton	117.00	''	''
Ms Lee-Anne Rentsch Rotachstrasse, 52 Zurich 8003, Switzerland	108.00	''	''
Robelyn Pty Ltd, 975 Whitehorse Road, Box Hill	108.00	''	''
Nicholas Roberts, 26 Bay Road, Mt Martha	108.00	''	''
Rosmin Robertson, 8 Stanton Crt, Glen Waverley	108.00	''	''
Mr Mark Roseman & Mrs Sharon Roseman, "Jemma Roseman A/c", 2A Chomley Street, Prahran	165.00	''	10/09/01
Mrs Hanna Claire Rosenbaum, C/ Whtm Asset Management Ltd, GPO Box 385, Brisbane, Qld	350.63	''	''
Mr John Russell, C/- D. M. G., GPO Box 7033, Sydney, NSW	825.00	''	''
Mr John Russell, C/- D. M. G., GPO Box 7033, Sydney, NSW	900.00	''	13/03/01
Ms Monika Rystwej, Unit 16, 40 Mount Street, West Perth, WA	108.00	''	''
Second Diviyar Pty Ltd, 5/175 Collins Street, Melbourne	825.00	''	10/09/01
Second Diviyar Pty Ltd, 5/175 Collins Street, Melbourne	900.00	''	13/03/01
Margaret Y. Seet, F11, 27 Montclair Ave, Glen Waverley	108.00	''	''
Mr Grant C. Sexton, "S. H. Prop P/L Sexton Fam A/c", 58 Wheatland Road, Malvern	108.00	''	''
Ms Jayne Ann Shallcross, 12 Creswick St, Clayfield, Qld	450.00	''	''
Ronald Simmons, 18 Vera Street, Oakleigh South	115.50	''	10/09/01
Simple Solutions (Vic) P/L, PO Box 634, Box Hill	108.00	''	13/03/01
Mrs Rosa Sita, 12 Picadilly Place, Sydenham	135.00	''	''
Mr David E. Smith, 15 Pickett Street, Dandenong	115.50	''	10/09/01
Ssorg Pty Ltd, "Gross Super A/c", 5 Glendene Court, Doncaster	165.00	''	''
Ssorg Pty Ltd, "Gross Super A/c", 5 Glendene Court, Doncaster	180.00	''	13/03/01

Mr Geoffrey David Star, 12 Kenley Court, Toorak	115.50	''	10/09/01
Mr Geoffrey David Star, 12 Kenley Court, Toorak	126.00	''	13/03/01
Mrs Allison Steigler, 14 Kimbarra Close, Belmont North, NSW	125.40	''	10/09/01
Anthony Stephens, 10 Rylston Court, Mt Eliza	108.00	''	13/03/01
David Sun, 39 Greens Road, Dandenong	115.50	''	10/09/01
Mrs Edna Doris Sutherland, 24 Stanley St, Black Rock	247.50	''	''
Mr Roderick Swallow & Mrs Sarah Elizabeth Swallow, "Swallows Hest S/Fund A/c", PO Box 552, Busselton, WA	437.25	''	10/09/01
Mr Roderick Swallow & Mrs Sarah Elizabeth Swallow, "Swallows Hest S/Fund A/c", PO Box 552, Busselton, WA	477.00	''	13/03/01
Bernard J. Taylor, 4 Sandara Court, Mt Eliza	108.00	''	''
Mr Stephen John Taylor & Ms Janet Ann Campbell, "Campbell Taylor S/Fund A/c", 569 Canning Street, North Carlton	330.00	''	10/09/01
Mr Stephen John Taylor & Ms Janet Ann Campbell, "Campbell Taylor S/Fund A/c", 569 Canning Street, North Carlton	360.00	''	13/03/01
Tetch Pty Ltd, C/- Dr John Connell, Apt 163-461, St Kilda Road, Melbourne	247.50	''	10/09/01
Miss Kerry Joyce Thomas, 3 The Crest, Killara, NSW	247.50	''	''
Miss Kerry Joyce Thomas, 3 The Crest, Killara, NSW	270.00	''	13/03/01
Kevin A. Thomas, 26 Yaralla Rd, Oakleigh South	108.00	''	''
World Vision Travel, Queenie Tan, 704C Station St, Box Hill	108.00	''	''
Dam N. Trinh, 68 Hansworth Street, Mulgrave	115.50	''	10/09/01
Dam N. Trinh, 68 Hansworth Street, Mulgrave	126.00	''	13/03/01
Truite Pty Ltd, PO Box 137, Canterbury	115.50	''	10/09/01
Ching Long Tsai & Hsiuying Hung Tsai, 2/50 Foote Street, Templestowe	108.00	''	13/03/01
Mr Vinh Hue Tsan, 990 Glen Huntly Road, Caulfield South	247.50	''	10/09/01
Ian Ulph & Rosemary Ulph, 7 Goodwin Street, Glen Iris	108.00	''	13/03/01
Gerry James Peter Van Ameyden, Unit 4, 5 Cherryhinton Street, Box Hill	173.25	''	10/09/01
Yelena Viknyansky, 4 Ramsay Street, Brighton	108.00	''	13/03/01
Mrs Stefanie Kastner-Walmsley, "S. A. Kastner-Walmsley A/c", Collinswood, Woodbridge Farway, Nr Colyton, Devon, GBR	153.00	''	''
Mr Graeme Watkins, 1/5 Anderson Court, Mentone	270.00	''	''
Ms Ann Whyte, C/- Pavletich, Level 2 , 222 Clarence Street, Sydney, NSW	511.50	''	10/09/01
Wichita Pty Ltd, "Barnett Family A/c", 27 Kinane Street, Brighton	825.00	''	''
Mr Daryl J. Wilkinson, 34 Mills Street, Hampton	108.00	''	13/03/01
Tony Wolfenden, 62 Addison Street, Elwood	115.50	''	10/09/01
Mr Oswald V. Wolkenstein & Mrs Jacqueline P. Wolkenstein, 3/10 Tuckwell Place, Macquarie Park, NSW	180.00	''	13/03/01
Mr Patrick Yii & Mrs Viviana Yii, "Patviv Super Fund A/c", 219F Foote Street, Templestowe	115.50	''	10/09/01
Mr Leslie James Bruce Young, 9 Harcourt Street, Weetangera, ACT	330.00	''	''
Mr Michael James Young & Mrs Jodi Marie Young, C/- Tower Trust Limited, GPO Box 546, Adelaide, SA	247.50	''	10/09/01

03127

CONTACT: ELAINE HARE, PHONE: (03) 9611 5714.

Unclaimed Moneys Act 1962

Register of Unclaimed Moneys held by the —

<i>Name of Owner on Books and Last Known Address</i>	<i>Total Amount Due to Owner</i>	<i>Description Of Unclaimed Money</i>	<i>Date when Amount first became Payable</i>
UNITED ENERGY LIMITED			
	\$		
Opticon P/L, 11/350 Collins Street, Melbourne	285.76	Cheque	04/12/00
Sheldon Park P/L, 348 South Road, Moorabbin	289.52	"	11/12/00
Austar Corporation, C/- Onsite Hocking Hire, 95 Edithvale Road, Edithvale	125.09	"	"
Michael's P/L, Fcty 6, 273 Wickham Rd, Moorabbin	494.70	"	13/12/00
Lunchez On Highbury, 73 Winmalee Drive, Glen Waverley	261.80	"	20/12/00
Estate of Martin J. Thyssen, 105 Ash Street, Doveton	106.80	"	"
Boulderstone Hornibrook Projects, P.O. Box 2566, Kentown	149.05	"	28/12/00
Peter Yang, trading as Smart Vision, Floor1/264 Charman Road, Cheltenham	747.70	"	"
Et's Bakery (previous owners), Shop 28, P'wood Shop. Centre, Blackburn Rd, Mt Waverley	444.81	"	23/05/01
Maria Gialis, 23 Koornang Road, Carnegie	256.36	"	30/05/01
City of Monash, Private Box No. 14650, Melbourne City MC	120.00	"	02/03/01
AVI Milder Pty Ltd, C/- Eberleci, Ripponlea	120.00	"	"
Van Chiem, 20 Thomas Street, Clayton	225.00	"	"
William & Andree Amour, 19A Vera Street, Frankston	120.00	"	"
Dawson's Australia Pty Ltd, 43 Military Road, Avondale Heights	176.00	"	21/03/01
Australia Post, PO Box 5218BB, Melbourne	238.80	"	23/07/01
Beth Lucena & David McLeod, 37 Eastgate Street, Oakleigh	217.31	"	01/10/01
Land Victoria Titles Services, 283 Queen Street, Melbourne	328.00	"	31/10/01

03022

CONTACT: TONY KARAGIANNIS, PHONE: (03) 9222 8526.

Unclaimed Moneys Act 1962

Register of Unclaimed Moneys held by the —

<i>Name of Owner on Books and Last Known Address</i>	<i>Total Amount Due to Owner</i>	<i>Description Of Unclaimed Money</i>	<i>Date when Amount first became Payable</i>
VILLAGE ROADSHOW LIMITED			
\$			
Bluegage Pty Ltd, "R. A. & D. M. Lewy Super Fund A/c", PO Box 2138, North Parramatta, NSW	252.13	Cheque	21/11/01
Ms Maria Violet Buckler, C/- Ernst & Young Registry Services Pty Ltd, PO Box 505H, Melbourne	101.50	"	"
Mr Mathew Paul Byrne, 5 Wilbraham Court, Frankston Cantaster Pty Ltd, "D. Vanblerk A/c", Level 11, 52-58 Clarence Street, Sydney, NSW	107.63	"	"
Mr Borg Chan, 17 Blaxland Street, Yennora, NSW	143.50	"	"
Mr Leslie Phillip Crichton, PO Box 179, Dowerin, WA	215.25	"	"
Mr Mark Charles Davis, Suite 3, 17 Waterloo Street, Cleveland, Qld	269.64	"	"
Mr Peter De Winter, 42 Ferncroft Avenue, Hampstead, London NW3 7PE, UK	179.38	"	"
Mr Vincent Anthony Doquile, 128 Mont Albert Road, Canterbury	607.28	"	"
Mrs Tracey Anne Duxbury, 630 Trouts Road, Aspley, Qld	216.25	"	"
Mr Ross Entwistle, 57 Perth Street, Prahran	203.50	"	"
Mr Daniel Fellman, 4 Lighthouse Street, Unit 8, Marina Del Ray, California 90292, United States	117.01	"	"
Mr James Fitter, 68 Portland Road, Notting Hill W11 4IQ, London, UK	162.27	"	"
Fynwand Pty Limited, 18 Marion Street, Leichhardt, NSW	370.00	"	"
Fynward Pty Limited, 18 Marion Street, Leichhardt, NSW	485.80	"	"
Gatalea Pty Limited, C/- Ernst & Young Registry Services Pty Ltd, GPO Box 505H, Melbourne	335.94	"	"
Mr Jason Hetherington, C/-IPAC Securities Limited, Level 28, 225 George Street, Sydney, NSW	203.00	"	"
Mr Marshall John Hinz, 38 Ridley Road, Bridgeman Downs, Qld	116.59	"	"
Miss Ying Ying Hui, 18F Royal Court, 9M Kennedy Rd, Wanchai, Hong Kong	358.75	"	"
Jeffrey Hayes Productions Inc, "Seperate Property A/c", Goldman & Knell, 1900 Avenue of The Stars, Suite 1040, Los Angeles, California	216.55	"	"
Mr David Joachim, PO Box 763, South Yarra	314.95	"	"
Kannabale Pty Ltd, "The O'Hare Family A/c", 19 Atchison Street, St Leonards, NSW	107.63	"	"
Miss Natasha Alexandra Kassar, C/- Carolco Services, 8800 Sunset Boulevard, Los Angeles, California 90069, United States	253.75	"	"
Dr Frank John Kelly, 195 Bateau Bay Road, Bateau Bay, NSW	652.50	"	"
	114.80	"	"

Mr Glenn Kennedy, Unit 4, 42 Ramsay Street, Kedron, Qld	180.43	''	''
Miss Sabina Kuntze, 1 Stanley Avenue, Hawthorn East	107.63	''	''
Mr Brad Peter Lauder, C/- Corporate Registry Services, GPO Box 505H, Melbourne	101.50	''	''
Mr Leo Anthony Luton & Mr Christopher John Cooney, "The Dossie Weir A/c", Gilshenan & Luton, PO BOX 296, North Quay, Qld	875.60	''	''
Mr Michael Patrick Lynagh, 59 Meiers Road, Indooroopilly, Qld	101.50	''	''
Mrs Catherine Ellen Lyons, C/- Fox, PO Box A760, South Sydney, NSW	376.48	''	''
Mrs Sharonlee MacDonald, C/- Mr C. Charlton, GPO Box 188, Sydney, NSW	1,435.00	''	''
Ms Adrienne Dawn Martin, C/- Ernst & Young Registry Services Pty Ltd, PO Box 505H, Melbourne	172.20	''	''
Mr Justin Anthony Martin, Suite 210, 210 Melbourne Street, West End, Qld	380.28	''	''
Mr Wayne Gregory McIntosh, 4 The Watchtower, Salamander Bay, NSW	101.75	''	''
Mr Richard Mews & Mrs Wee Khoon Mews, "Mews Superannuation Fund A/c", 8 Fairfax Road, Bellevue Hill, NSW	1,435.00	''	''
Mr David Anthony Morris, 5/23 Havannah Street, Bathurst, NSW	203.50	''	''
Mumbto Pty Limited, 69 The Point Rd, Woolwich, NSW	2,991.98	''	''
Mr Charles Newton, C/- Ernst & Young Registry Services Pty Ltd, GPO Box 505H, Melbourne	101.50	''	''
Ms Anna O'Connor, 8/136 Cross Road, Highgate, SA	1,836.05	''	''
Orthotic Specialist Centre Pty Ltd, PO Box 2101, Hawthorn	183.30	''	''
Mr Michael Owen, 39 Mont Victor Road, Kew	173.20	''	''
Paul Hogan Enterprises Pty Ltd, C/- Greenwood Challoner Services Pty Ltd, GPO Box 4265, Sydney, NSW	2,950.75	''	''
Perpetual Trustee Company Limited, "BNP A/c", GPO Box 5106, Sydney, NSW	904.05	''	''
Mr John Pomeroy Perry, PO Box 195, Lindfield, NSW	144.94	''	''
Mr Paul Anthony Raftery, 14 Haughton St, Red Hill, Qld	143.50	''	''
Mr David Reardon, 4000 Warner Boulevard, Burbank, California 91522, United States	2,430.48	''	''
Mr Stephen John Rich, RMB 4200, Palmdale Road, Ourimbah, NSW	179.38	''	''
Miss Julia Katherine Ritchie, PO Box 222, Waterloo, NSW	430.50	''	''
Riverina Wholesale Traders Pty Ltd, "Employees Super Fund A/c", 8 Baree Place, Wagga Wagga, NSW	288.00	''	''
Mr Colin Rogers, 3 Jacaranda Close, Kotara, NSW	101.75	''	''
Mrs Susan Margaret Rozee, PO Box 56, Stirling North, SA	101.89	''	''
Dr A. Holyweek Sarei & Ms Claire Sarei, C/- Mr Francis Seeto, 108 Flockton St, Everton Park, Qld	253.75	''	''
Mr Mark Schmeling, 2 Wentworth Street, Arncliffe, NSW	127.74	''	''
Mr Archie Whitelaw Shaw & Mrs Janet Vera Shaw, 50 Glenview Road, Upper Coomera, Qld	255.48	''	''
Ms Jane Elizabeth Sherning, C/-Corporate Registry Services Services Pty Ltd, GPO Box 505H, Melbourne	253.75	''	''

Ms Leigh Short, Apartment 12K, 124 W, 60th Street, New York, New York 1023, United States of America	925.50	”	”
Ms Leigh Short, Apartment 12K, 124 W, 60th Street, New York, New York 1023, United States of America	462.75	”	”
Silverstream Nominees Pty Ltd, “C. E. A/c”, Level 29, 133 Castlereagh Street, Sydney, NSW	1,119.25	”	”
Mr Andrew Roy Newbery Sisson, “Claire Louise Sisson A/c”, 9 Bromby Street, South Yarra	108.63	”	”
Mr Andrew Roy Newbery Sisson, “Oliver M. A. Sisson A/c”, 9 Bromby Street, South Yarra	152.63	”	”
Mr Andrew Roy Newbery Sisson, “Penelope C. Sisson A/c”, 9 Bromby Street, South Yarra	152.63	”	”
Mrs Gemma Louise Doyle-Smith, 7 Ash Grove, Malvern East	143.50	”	”
Mr John Mark Steen, C/-Corporate Registry Services, GPO Box 505H, Melbourne	101.50	”	”
Steesar Nominees Pty Ltd, C/-Mr Frank Cox, 2nd Floor, 252 Bay Street, Port Melbourne	316.44	”	”
Ms Constance E. Stephens & Mr William Ernest Foran, PO Box 46, Ingleburn, NSW	143.50	”	”
Mr Wayne Stewart Flight, Ops Fc-449 Emirates, PO Box 92, Dubai, United Arab Emirates	293.75	”	”
Mrs Glenda Trotman, 3 Turner Street, Leongatha	215.25	”	”
Mr John Wesley Turnbull, 14 Glenfern Road, Epping, NSW	287.00	”	”
Mr John Walsh, C/- Walsh James, 5/17 Castlereagh Street, Sydney, NSW	152.25	”	”
Mr Justin Stephen White, 16 Carroll Street, Bardon, Qld	652.25	”	”
Mrs Xiao Mei Zeng, Unit 4, 60 Victoria Avenue, Penshurst, NSW	107.63	”	”

03128

CONTACT: ELAINE HARE, PHONE: (03) 9611 5714.

Unclaimed Moneys Act 1962

Register of Unclaimed Moneys held by the —

<i>Name of Owner on Books and Last Known Address</i>	<i>Total Amount Due to Owner</i>	<i>Description Of Unclaimed Money</i>	<i>Date when Amount first became Payable</i>
WILLMOTT FORESTS LIMITED			
\$			
Three Macs Pty Ltd, “M. D. Micomb Family Trust A/c”, 99 Coventry Street, South Melbourne	360.00	Cheque	01/10/01

03129

CONTACT: ELAINE HARE, PHONE: (03) 9611 5714.

**GOVERNMENT AND OUTER BUDGET SECTOR AGENCIES
NOTICES**

BOROONDARA CITY COUNCIL
Road Discontinuance

Pursuant to Section 206 and Schedule 10, Clause 3 of the **Local Government Act 1989**, the Boroondara City Council has formed the opinion that the road adjacent to 5 Beatrice Street, Kew, and shown by hatching on the plan below, is not reasonably required as a road for public use and resolved to discontinue the road and to sell the land from the road by private treaty to the abutting property owner.

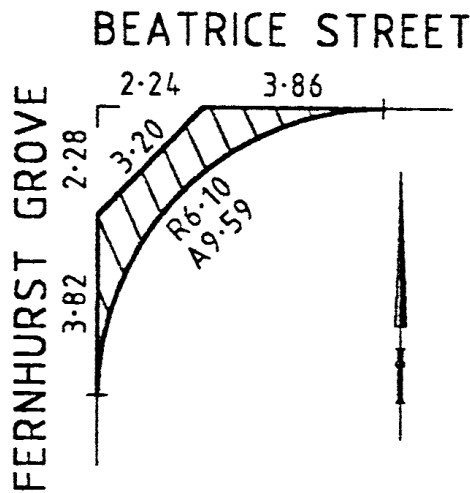

PETER JOHNSTONE
Chief Executive Officer

WHITEHORSE CITY COUNCIL
Road Discontinuance

Pursuant to Section 206 and Schedule 10, Clause 3 of the **Local Government Act 1989**, the Whitehorse City Council has formed the opinion that the road at the rear of 37 to 57 Olympiad Crescent, 1 to 21 Saxton Street & 84 to 86 Shannon Street and adjacent 86 & 88 Shannon Street & 1A Saxton Street, Box Hill North, as shown hatched and cross-hatched on the plan below, is not reasonably required as a road for public use and resolved to discontinue the road and to sell the land from the road by private treaty to the abutting property owners.

The section of road shown cross-hatched is to be sold subject to the right, power or interest held by Yarra Valley Water Limited, in the road

in connection with any sewers, drains, or pipes, under the control of that authority in or near the road.

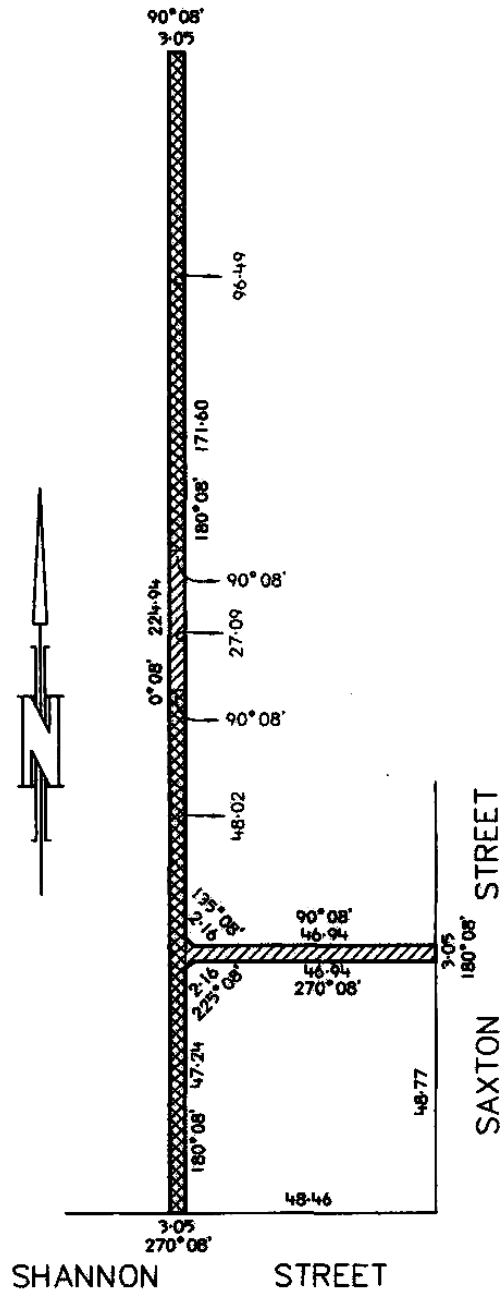

NOELENE DUFF
Chief Executive Officer

GLEN EIRA CITY COUNCIL
Road Discontinuance

Acting under Section 206 and Clause 3 of Schedule 10 to the **Local Government Act 1989**, Glen Eira City Council has resolved that the road shown by hatching on the plan below, be discontinued and sold.

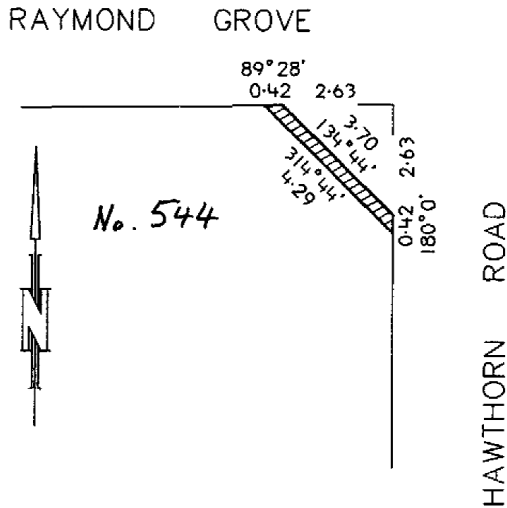

ANDREW NEWTON
Chief Executive Officer



MOORABOOL SHIRE COUNCIL

Making of Order for the Restraint of Dogs

Notice is hereby given, as required by Section 26(3) of the **Domestic (Feral and Nuisance) Animals Act 1994**, that Council, on 11 June 2003, resolved to make the following Order pursuant to Section 26(2) of the Act:

“All dogs must be kept under the effective control of a person by means of a chain, cord or leash when in any public place (including but not limited to any park, footpath, nature strip, traffic island, market and shared pathway) within Council’s municipal district except where:

- (i) the dog is participating in any activity of a type which has been approved by resolution of Council; or

- (ii) any of the circumstances listed in Section 20(2) of the **Domestic (Feral and Nuisance) Animals Act 1994** applies”.

ROBERT DOBRZYNSKI
Chief Executive Officer

STONNINGTON CITY COUNCIL
Erratum

On 27 December 2002 the Stonnington City Council gave notice in the Victoria Government Gazette of its resolution to discontinue the road abutting 366 Punt Road, South Yarra. The following supersedes that gazettal.

At its meeting on 17 December 2002 and acting under Clause 3 of Schedule 10 to the **Local Government Act 1989** Stonnington City Council resolved to discontinue the road shown as Lot 1 on the plan below.

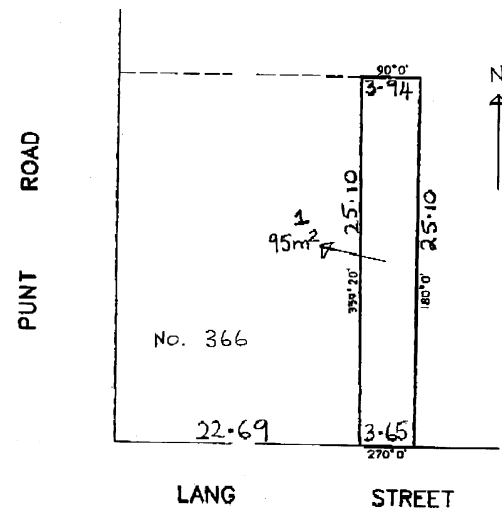

HADLEY SIDES
Chief Executive Officer

NORTHERN GRAMPIANS
SHIRE COUNCIL
Road Discontinuance

Pursuant to Section 206 and Schedule 10, Clause 3 of the **Local Government Act 1989**, the Northern Grampians Shire Council at its ordinary meeting held on 5 June 2003 formed the opinion that the unnamed road shown hatched on the plan below and being part of a Government Road Reserve in the Parish of

Glenorchy, is not reasonably required as a road for public use and has resolved to discontinue the road to allow implementation of LCC Recommendation 16 for Bushland Reserve.

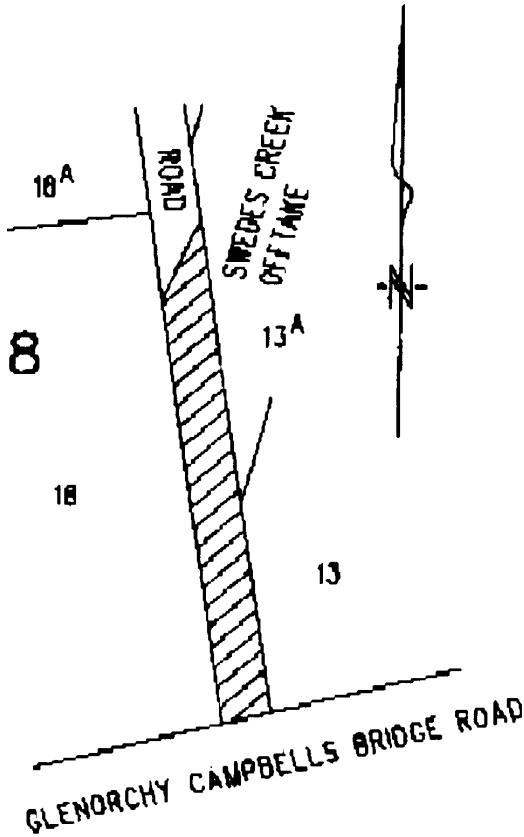

PETER BROOKS
Chief Executive Officer

NORTHERN GRAMPIANS
SHIRE COUNCIL
Road Discontinuance

Pursuant to Section 206 and Schedule 10, Clause 3 of the **Local Government Act 1989**, the Northern Grampians Shire Council at its ordinary meeting held on 5 June 2003 formed the opinion that the unnamed road shown hatched on the plan below and being part of a Government Road Reserve in the Parish of Illawarra, is not reasonably required as a road for public use and has resolved to discontinue the road to allow implementation of LCC Recommendation 159 for Bushland Reserve.

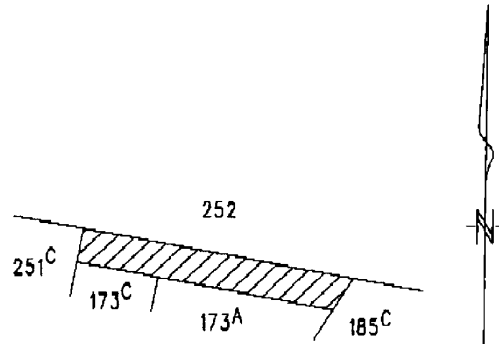

PETER BROOKS
Chief Executive Officer

NORTHERN GRAMPIANS
SHIRE COUNCIL
Road Discontinuance

Pursuant to Section 206 and Schedule 10, Clause 3 of the **Local Government Act 1989**, the Northern Grampians Shire Council at its ordinary meeting held on 5 June 2003 formed the opinion that the unnamed road shown hatched on the plan below and being part of a Government Road Reserve in the Parish of Riachella, is not reasonably required as a road for public use and has resolved to discontinue the road to allow implementation of LCC Recommendation 11 for Bushland Reserve.

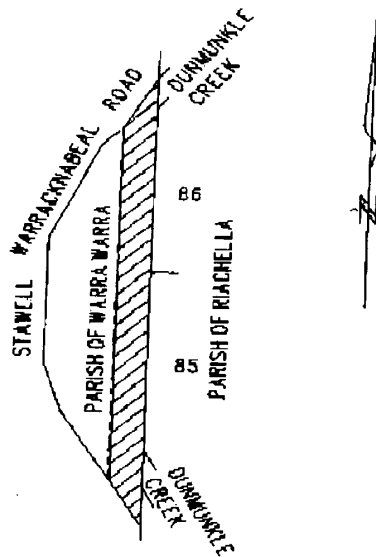

PETER BROOKS
Chief Executive Officer

NORTHERN GRAMPPIANS
SHIRE COUNCIL

Road Discontinuance

Pursuant to Section 206 and Schedule 10, Clause 3 of the **Local Government Act 1989**, the Northern Grampians Shire Council at its ordinary meeting held on 5 June 2003 formed the opinion that the unnamed road shown hatched on the plan below and being part of a Government Road Reserve in the Parish of Wallaloo, is not reasonably required as a road for public use and has resolved to discontinue the road to allow implementation of LCC Recommendation 124 for Bushland Reserve.

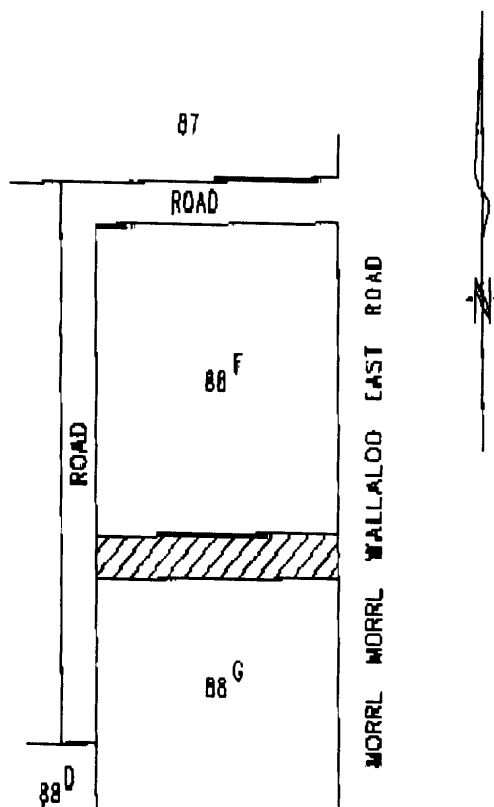

PETER BROOKS
Chief Executive Officer

CITY OF MARIBYRNONG
Roads Municipal Property and Council Land
Local Law Number 2

Notice is given pursuant to Section 224A of the **Local Government Act 1989**, the City of

Maribyrnong at its Ordinary Council meeting held on 23 June 2003 formed the opinion that the provision of Roads Municipal Property and Council Land Local Law Number 2, Clauses 39 & 40, stating:

“Unless in accordance with a permit, in a specified area, a person must not: consume alcohol; or be in possession or control of a container of alcohol unless it has been not been opened; or allow another person to do so in, or on Council premises or a public area (in or on a stationary or moving vehicle situated in or on that place) except premises which are:

3. licensed for that purpose under the **Liquor Control Act 1987**; or
4. in an area which the consumption of alcohol is authorised in accordance with a permit under the **Liquor Control Act 1987**”

shall be extended to the following area: Walker Oval, Hansen Reserve, located on Roberts Street, West Footscray. (Melway Ref: 41, G5).

This provision is to apply only for the home matches of the North Footscray Football Club for the following dates and times:

- 28 June, 8 am – 5 pm;
- 12 July, 8 am – 5 pm;
- 19 July, 8 am – 5 pm;
- 2 August, 8 am – 5 pm.

Notice also be given pursuant to Section 224A of the **Local Government Act 1989** that any member of the Victoria Police may enforce this provision in these specified areas.

ANTHONY SMITH
Acting Chief Executive Officer

MACEDON RANGES SHIRE COUNCIL

Notice of Intention to make a Local Law
Macedon Ranges Shire Council
General Local Law No. 8

The Macedon Ranges Shire Council proposes to make a new local law, to be referred to as the Macedon Ranges Shire Council General Local Law No. 8.

At its Ordinary Meeting on 11 June 2003 Council resolved pursuant to Section 119 of the **Local Government Act 1989** to advertise its intention to make this local law.

Purpose of the Local Law

This Local Law is made for:

- a) providing for the peace, order and good government of the Shire of Macedon Ranges;
- b) providing a safe and healthy environment in which the residents of the Shire of Macedon Ranges may enjoy a quality of life that meets the general expectations of the community;
- c) preventing and suppressing nuisances which may adversely affect the enjoyment of life within the municipal district or the health, safety and welfare of persons within the municipal district;
- d) prohibiting activities which may be dangerous or unsafe or detrimental to the quality of life and the environment of the municipal district.

General Purport of the Local Law

The proposed local law, if made, will:

- a) regulate activities which may adversely affect the environment and the health and wellbeing of persons within the municipal district;
- b) regulate and control access to and behaviour in Municipal Places;
- c) protect Council land and assets;
- d) prohibit interference with water courses and drains;
- e) regulate and control vehicle crossings;
- f) prohibit the keeping of unsightly land;
- g) regulate and control the storage, assembly and dismantling of old machinery, materials, goods or services on land;
- h) regulate and control camping and the use of caravan, tents and like structures;
- i) prohibit vegetation which may constitute a traffic hazard;
- j) prohibit vegetation and structures overhanging roads;
- k) prohibit the encroachment of vegetation on roads and Council land;
- l) provide for the destruction of vermin and noxious weeds;
- m) prevent fire risks;
- n) regulate and control the numbering of allotments;

- o) prohibit unreasonable noise;
- p) regulate and control the use of scareguns within the municipal district in a manner that prevents their use being detrimental to the environment or to the quality of life of persons residing in or visiting the municipal district;
- q) regulate and control open air fires and the use of incinerators;
- r) provide for sanitary facilities on building sites;
- s) prohibit the dilapidation of buildings;
- t) regulate and control dogs;
- u) regulate and control the placement of goods, advertising signs and furniture on roads and Council land;
- v) regulate and control obstructions on roads;
- w) regulate and control works on roads;
- x) prohibit the performance of work on vehicles on roads, and Council land;
- y) regulate and control the consumption and possession of alcohol on roads and Council land;
- z) regulate and control the sale of goods;
- aa) regulate and control street collections and distributions;
- bb) regulate and control the distribution of unsolicited material;
- cc) regulate and control busking;
- dd) regulate clothing recycling bins on Council land;
- ee) prohibit spoil on roads;
- ff) provide for bulk rubbish containers on building sites;
- gg) regulate the use of heavy motor vehicles on land;
- hh) regulate and control the keeping of animals;
- ii) provide for the collection, storage and transportation of refuse, trade waste, hard garbage and recyclable materials.

Submissions

A copy of the proposed local law may be inspected at Council Offices in Kyneton, Woodend, Romsey and Gisborne or a copy obtained by contacting Stephen Mahon, Manager Council & Customer Services on 5422 0352 or via e-mail to stephen@macedon-ranges.vic.gov.au.

The proposed local law is also available at Council's website
<http://www.macedon-ranges.vic.gov.au>

Any person affected by the proposed local law may make a submission relating to it to the Council. Submissions received by the Council by 23 July 2003 will be considered in accordance with section 223 of the **Local Government Act 1989**. Any person requesting to be heard in support of a written submission is entitled to appear before a meeting of the Council or a Council Committee either personally or by a person acting on his or her behalf and will be notified of the time and date of this hearing. Copies of all submissions received will be made available for public inspection.

Submissions should be lodged at the Kyneton Administration Centre, 129 Mollison Street, Kyneton or posted to PO Box 151, Kyneton 3444.

Submissions are also invited with respect to the competition aspects of the proposed local law, including the costs/benefits of any restrictions on competition.

IAN MORRIS
 Chief Executive

Planning and Environment Act 1987

BALLARAT PLANNING SCHEME

Notice of Amendment to a Planning Scheme

Amendment C65

The City of Ballarat has prepared Amendment No. C65 to the Ballarat Planning Scheme.

The City of Ballarat has undertaken a review of its Municipal Strategic Statement (MSS) and a new MSS has been developed as a result of that review. The Amendment therefore proposes to replace the existing MSS with the new MSS.

The Amendment can be inspected at any of the following locations: City of Ballarat, The Phoenix, 25 Armstrong Street South, Ballarat; Department of Sustainability and Environment, Central Highlands and Wimmera Regional Office, 88 Learmonth Road, Wendouree (VicRoads Office) and Department of Sustainability and Environment, Nauru House, 80 Collins Street, Melbourne.

Submissions about the Amendment must be sent to the Chief Executive Officer, City of Ballarat, PO Box 655, Ballarat, Vic. 3353, and will be accepted until 5.00 pm, Monday 28 July 2003. All submissions should clearly state all of the grounds on which you support or oppose the Amendment and indicate whether you wish to be heard in respect of the submission at any subsequent panel hearing.

JOHN McLEAN
 Chief Executive Officer

Planning and Environment Act 1987

CASEY PLANNING SCHEME

Notice of the Preparation of an Amendment

Amendment C59

The land affected by the Amendment is 160 Berwick–Cranbourne Road, Cranbourne East, being Lot 2 on PS 409054X.

The Amendment proposes to rezone part of the land from a Rural Zone – Schedule 6 (RUZ6) to a Public Park and Recreation Zone (PPRZ) to facilitate the development of the site for a major sports and recreation facility known as 'Casey Fields'.

The person who requested the Amendment is the Casey City Council.

You may inspect the Amendment; any documents that support the Amendment; and the explanatory report about the Amendment at the office of the planning authority: City of Casey, Municipal Offices, Magid Drive, Narre Warren; Casey City Council, Customer Service Centre, Cranbourne Park Shopping Centre (opposite Post Office), Cranbourne and at: Department of Sustainability and Environment, Planning Information Centre, Upper Plaza, Nauru House, 80 Collins Street, Melbourne.

This can be done during office hours and is free of charge.

The Amendment is also available for viewing in Adobe Acrobat format, on the City of Casey website at
<http://www.casey.vic.gov.au/planningexhibition/section.asp>.

Any person who may be affected by the Amendment may make a submission to the planning authority.

The closing date for submissions is 28 July 2003. A submission must be sent to: Manager Planning, Casey City Council Municipal Offices, PO Box 1000, Narre Warren 3805.

Should you have any queries about this Amendment, please contact Michael Pollard on 9705 5589.

Dated 26 June 2003

ROBERT BAGGIO
Manager Planning

Planning and Environment Act 1987

MORELAND PLANNING SCHEME

Notice of Preparation of Amendment

Amendment C39

The Moreland City Council has prepared Amendment C39 to the Moreland Planning Scheme.

The Amendment affects 178 properties across the municipality.

The Amendment proposes to remove the Environmental Audit Overlay from the 178 properties.

You may inspect the Amendment, any documents that support the Amendment and the explanatory report about the Amendment at the following locations: at the office of the planning authority, Moreland City Council, 90 Bell Street, Coburg and at the Department of Sustainability and Environment, Planning Information Centre, Upper Plaza, Nauru House, 80 Collins Street, Melbourne.

This can be done during office hours and is free of charge.

Any person who may be affected by the Amendment may make a submission to the planning authority.

The closing date for submissions is Monday 28 July, 2003. A submission must be sent to the Moreland City Council: Submission to Amendment C39, Strategic Planning Unit, Moreland City Council, Locked Bag 10, Moreland, Vic. 3058.

JANE HOMEWOOD
Acting Director City Strategy

Planning and Environment Act 1987

WHITEHORSE PLANNING SCHEME

Notice of the Preparation of an Amendment to a Planning Scheme

Amendment C40

The land affected by the Amendment is the land within the Blackburn Station Shopping Centre, comprising the properties within the Centre, as follows:

- All of Lithgow Street, Blackburn;
- East side of Downing Street, Blackburn;
- All of Hindon Street, Blackburn;
- All of Railway Road, Blackburn;
- All of Vine Street, Blackburn;
- All of Station Street, Blackburn;
- All of Queen Street, Blackburn;
- All of Albert Street, Blackburn;
- All of Chapel Street, Blackburn;
- 72–178 Whitehorse Road, Blackburn (even side only);
- All of Mary Street, Blackburn;
- All of George Street, Blackburn;
- All of Cottage Street, Blackburn;
- West side of Alfred Street, Blackburn;
- Elmore Walk, Blackburn;
- South Parade, Blackburn;
- 37–77 and 36–68 Laburnum Street, Blackburn;
- 17, 19, 21, 23, 25, 27, 33, 35, 37, 39 The Avenue, Blackburn;
- 3, 5, 7 Laurel Grove North, Blackburn;
- 1–27 and 2–22 Main Street, Blackburn;
- 1–29 and 2–32 Gardenia Street, Blackburn;
- 1–40, 43, 47, 49, 51 Blackburn Road, Blackburn;
- North side of Wolseley Crescent, Blackburn;
- All of Gordon Crescent, Blackburn;
- All of Clarke Street, Blackburn;
- 2–30 Central Road, Blackburn.

The Amendment proposes to:

- vary the Municipal Strategic Statement and Local Planning Policy Framework to ensure that planning decisions in the Blackburn Station Shopping Centre are consistent with the aims of both the business plan and the parking precinct plan;

- insert a new planning policy (Clause 22.12) for the Blackburn Station Shopping Centre;
- insert a Schedule to Clause 52.06 (Car Parking) in the Whitehorse Planning Scheme, to reflect the different rates included in the Parking Precinct Plan;
- include the Blackburn Station Shopping Centre Parking Precinct Plan, Final Report, June 2003, within Clause 81 as an Incorporated Document.

You may inspect the Amendment, and any documents that support the Amendment, and the explanatory report about the Amendment, at the office of the planning authority, Whitehorse City Council and at the Department of Sustainability and Environment at the following addresses:

- the City of Whitehorse, Statutory Planning Office, Service Centre, 379 Whitehorse Road, Nunawading;
- Department of Sustainability and Environment, Planning Information Centre, Level 3 Plaza, Nauru House, 80 Collins Street, Melbourne;
- all libraries and the Service Centres at Box Hill and Forest Hill and on the Internet at www.whitehorse.vic.gov.au/what-docs.asp

This can be done during office hours and is free of charge.

Any person who may be affected by the Amendment may make a submission to the planning authority.

Any submission about the Amendment must: be made in writing, giving the submitter's name, address and, if practicable, a phone number for contact during office hours; set out the views on the Amendment, that the submitter wishes to put before Council and indicate what changes (if any) the submitter wishes to be made to the Amendment; and state whether the person/s making the submission wishes to be heard in support of their submission.

The closing date for submission is 31 July 2003. A submission must be sent to: Ms Helen Woodside, Senior Urban Planner, Projects, City of Whitehorse, Locked Bag 2, Nunawading Delivery Centre, Vic. 3110.

Privacy Statement

Any personal information you may include in any submission to Council on the Amendment is collected for planning purposes in accordance with the **Planning and Environment Act 1987** (the Act). The public may view the submission whilst the Amendment is being considered. In accordance with the "Improving Access to Planning Documents" Practice Note dated

December 1999, a copy of your submission may be made upon request. If you fail to provide this information your comments may not be considered. You may access this information by contacting Council on 9262 6349.

Dated 12 June 2003

Mr IAN GOODES
Acting General Manager,
City Development

Creditors, next-of-kin and others having claims against the estate of any of the undermentioned deceased persons are required to send particulars of their claims to State Trustees Limited, ABN 68 064 593 148, 168 Exhibition Street, Melbourne, Victoria 3000, the personal representative, on or before 1 September 2003 after which date State Trustees Limited may convey or distribute the assets having regard only to the claims of which State Trustees Limited then has notice.

ANSELL, Alfred Ernest, formerly of 3 King Parrot Court, Flowerdale, but late of Kia Ora Private Nursing Home, 742 High Street, Regent, Victoria 3073, retired and who died on 31 March 2003.

CORNISH, Clement William, late of 25 Collins Street, Geelong West, pensioner, and who died on 8 August 2002.

HAKSTOK, Anton, late of 26 Grayling Court, Croydon, pensioner, and who died on 5 March 2003.

HOMEWOOD, Esther, formerly of 11 Jackson Avenue, North Box Hill, but late of Hillview Private Nursing Home, 764 Canterbury Road, Surrey Hills, Victoria, retired, and who died on 28 April 2003.

HOUSTON, Norman Edward, late of Aaron Private Nursing Home, 577 Neerim Road, Hughesdale, retired, and who died on 25 March 2003

MEYER, David Frederick, late of 88 Roden Street, West Melbourne, and who died on 12 April 2003.

PEERS, Keilora Josephine Valdine, late of Innisfree Private Nursing Home, 70 Jennings Street, Kyneton, and who died on 14 January 2003.

Dated at Melbourne, 23 June 2003

LAURIE TAYLOR
Estate Manager,
State Trustees Limited

STATE TRUSTEES LIMITED
ACN 064 593 148

Section 79

Notice is hereby given that State Trustees Limited, ACN 064 593 148 intends administering the estates of:-

OLIVE GRACE BLAMEY, late of Aaron Nursing Home, 577 Neerim Road, Hughesdale, Victoria, retired, deceased, who died on 26 February 2003 leaving a Will dated 25 May 1994.

GEORGE ALEXANDER GRANT HARRIS, late of 2/112 Marong Road, Bendigo, Victoria, pensioner, deceased intestate, who died on 2 November 1999.

JACK IGNATIUS O'MALLEY, late of 5/12 Waterloo Crescent, St Kilda, Victoria, retired, deceased, who died on 19 May 2003 leaving a Will dated 29 July 1998.

EDGAR FRANK PRATT, late of Caulfield Hospital, Tamarind Court, 260 Kooyong Road, Caulfield, Victoria, pensioner, deceased, who died on 23 March 2003 leaving a Will dated 22 July 2002.

Creditors, next-of-kin and others having claims against the abovementioned estates are required pursuant to Section 33 of the **Trustee Act 1958** to send particulars of their claims against the abovementioned estates to State Trustees Limited, 168 Exhibition Street, Melbourne, Victoria, on or before 1 September 2003 after which date State Trustees Limited, ACN 064 593 148, may convey or distribute the assets of the abovementioned estates having regard only to the claims of which it then has notice.

Department of Treasury and Finance

SALE OF CROWN LAND
BY PUBLIC AUCTION

Date of Auction: Friday 1 August 2003 at 2.00 p.m. on site.

Reference: 2003/00087.

Address of Property: 83 High Street, Avoca.

Crown Description: Crown Allotment 11, Section 32, Township of Avoca, Parish of Avoca.

Terms of Sale: Deposit 10%, Balance 60 days.

Area: 991 m².

Officer Co-ordinating Sale: Lara Morton-Cox, Victorian Government Property Group, Department of Treasury and Finance, 5/1 Treasury Place, Melbourne, Vic. 3002.

Selling Agent: Maryborough First National Real Estate, 127 High Street, Maryborough, Vic. 3465.

JOHN LENDERS MLC
Minister for Finance

Co-operatives Act 1996

MARLBOROUGH CO-OPERATIVE
SOCIETY LTD
TALLANGATTA HIGH SCHOOL
CO-OPERATIVE LIMITED

Notice is hereby given in pursuance of Section 316(1) of the **Co-operatives Act 1996** and Section 601AB(3) (e) of the **Corporations Act 2001** that, at the expiration of two months from the date hereof, the names of the aforementioned co-operatives will, unless cause is shown to the contrary, be struck off the register and the co-operatives will be dissolved. Dated at Melbourne 23 June 2003

ANDREW LEVENS
Deputy Registrar of Co-operatives

Co-operatives Act 1996

NOTICE OF ISSUE OF CERTIFICATE
OF REGISTRATION PURSUANT TO
SECTION 26(1)(b) OF THE
CO-OPERATIVES ACT 1996

Notice is hereby given pursuant to Section 26(1)(b) of the **Co-operatives Act 1996** that a certificate of registration was issued by the Registrar of Co-operatives on 17 June 2003 to Newstead Rural Transaction Centre Trading Co-operative Limited and the Co-operative is now incorporated under the said Act.

Dated at Melbourne 17 June 2003

ANDREW LEVENS
Deputy Registrar of Co-operatives

Electoral Act 2002

CHANGE TO REGISTER OF
POLITICAL PARTIES

In accordance with section 51(5)(e) of the **Electoral Act 2002**, I hereby give notice of the following change to the Register of Political Parties.

Name of registered political party:
Australian Labor Party—Victorian Branch

Name of new Registered Officer: Mr Erik Locke.

Dated 26 June 2003

C. A. BARRY
Victorian Electoral Commission

Fisheries Act 1995

**FISHERIES VICTORIA (ROCK LOBSTER
FISHERY) MANAGEMENT PLAN
DECLARATION 2003**

I, Bob Cameron, Minister for Agriculture, declare under section 28(1) of the **Fisheries Act 1995** that a management plan has been made with respect to the rock lobster fishery.

This Notice comes into operation on the day on which it is published in the Victoria Government Gazette.

Dated 21 May 2003

BOB CAMERON
Minister for Agriculture

Fisheries Act 1995

**FISHERIES VICTORIA (GIANT CRAB
FISHERY) MANAGEMENT PLAN
DECLARATION 2003**

I, Bob Cameron, Minister for Agriculture, declare under section 28 (1) of the **Fisheries Act 1995** that a management plan has been made with respect to the giant crab fishery.

This Notice comes into operation on the day on which it is published in the Victoria Government Gazette.

Dated 21 May 2003

BOB CAMERON
Minister for Agriculture

Magistrates' Court Act 1989

NOTICE OF KOORI COURT VENUES

Pursuant to section 4D(3) of the **Magistrates' Court Act 1989**, I direct that the Koori Court Division of the Magistrates' Court of Victoria sit and act at the following venue:

Warmambool

Dated 18 June 2003

IAN L. GRAY
Chief Magistrate



Heritage
VICTORIA

Heritage Act 1995

NOTICE OF REGISTRATION

As Executive Director for the purpose of the **Heritage Act 1995**, I give notice under section 46 that the Victorian Heritage Register is amended in that Heritage Register Number 553 in the category described as a Heritage place is now described as:

St Marks Anglican Church Complex,
268 George Street, Fitzroy, Yarra City Council.

EXTENT:

1. All the buildings and structures marked as follows on Diagram H553 held by the Executive Director.
 - B1 Church.
 - B2 Community Centre.
 - B3 Former Vestry and Sunday School.
 - B4 Vicarage.
 - B5 Parish Hall.
 - B6 Verger's House.
 - B7 George Street Hodgson Street Iron palisade fence and gate posts.
2. All the land in the area marked L1 shown on Diagram H553 held by the Executive Director.

Dated 26 June 2003

RAY TONKIN
Executive Director

Land Acquisition and Compensation Act 1986

FORM 7

S.21

Reg. 16

Notice of Acquisition

Compulsory Acquisition of Interest in Land

The Roads Corporation (VicRoads) declares that by this notice it acquires the following interest in the land described as part of Crown Allotments 4 & 8, Crown Section 4, Parish of Faraday comprising 4.003 hectares and being land described in Conveyance Book 771 No. 132, shown as Parcel 44 on Survey Plan 20447.

Interest acquired: That of Ronald Arthur Ellery and all other interests.

Published with the authority of VicRoads.
Dated 26 June 2003
For and on behalf of VicRoads:
GERRY TURNER,
Manager Property Services Department.

Land Acquisition and Compensation Act 1986

FORM 7 S.21
Reg. 16

Notice of Acquisition

Compulsory Acquisition of Interest in Land

The Roads Corporation (VicRoads), declares that by this notice it acquires the following interest in the land described as part of Lots 2 & 3 on Plan of Subdivision 125600, Parish of Faraday comprising 5.309 hectares and being land described in Certificate of Title Volume 9305, Folio 290; Certificate of Title Volume 9305, Folio 289, shown as Parcels 84 and 85 on Survey Plan 20449.

Interest Acquired: That of Thomas Francis Welford and all other interests.

Published with the authority of VicRoads.
Dated 26 June 2003

For and on behalf of VicRoads:
GERRY TURNER,
Manager Property Services Department.

Land Acquisition and Compensation Act 1986

FORM 7 S.21
Reg. 16

Notice of Acquisition

Compulsory Acquisition of Interest in Land

The Roads Corporation (VicRoads) declares that by this notice it acquires the following interest in the land described as part of Crown Allotment 11, Crown Section 4, Parish of Faraday comprising 3588.0 square metres and being land described in Conveyance Book 906, No. 589, shown as Parcel 23 on Survey Plan 20446.

Interest Acquired: That of Adrianus Ferdinandus Josef Slee and Helen Therese Slee and all other interests.

Published with the authority of VicRoads.
Dated 26 June 2003

For and on behalf of VicRoads:
GERRY TURNER,
Manager Property Services Department.

Land Acquisition and Compensation Act 1986

FORM 7 S.21
Reg. 16

Notice of Acquisition

Compulsory Acquisition of Interest in Land

The Roads Corporation (VicRoads) declares that by this notice it acquires the following interest in the land described as part of Crown Allotments 33 and 34, Crown Section 6, Parish of Faraday comprising 3.299 hectares and being land described in Certificate of Title Volume 10007, Folio 788; shown as Parcel 4 on Survey Plan 20445.

Interest Acquired: That of Stephen Joseph Norris and all other interests.

Published with the authority of VicRoads.
Dated 26 June 2003

For and on behalf of VicRoads:
GERRY TURNER,
Manager Property Services Department.

Land Acquisition and Compensation Act 1986

FORM 7 S.21
Reg. 16

Notice of Acquisition

Compulsory Acquisition of Interest in Land

The Roads Corporation (VicRoads) declares that by this notice it acquires the following interest in the land described as part of Crown Allotment 11, Section 20, Parish of Irrewarra, comprising 265 square metres and being land described in Certificate of Title Volume 6049, Folio 710, shown as Parcel 1 on Survey Plan 20468.

Interest acquired: That of Noel Raymond Tanis, Douglas John Tanis and Peter Francis Tanis and all other interests.

Published with the authority of VicRoads.
Dated 26 June 2003

For and on behalf of VicRoads:
GERRY TURNER,
Manager Property Services Department.

Land Acquisition and Compensation Act 1986

FORM 7 S.21
Reg. 16

Notice of Acquisition

Compulsory Acquisition of Interest in Land

The Roads Corporation (VicRoads), declares that by this notice it acquires the following

interest in the land described as part of Crown Allotment 9, Section 2, Parish of Faraday comprising 2.644 hectares and being land described in Book 776, Memorial 35; shown as Parcel 87 on Survey Plan 20449.

Interest Acquired: That of Tom and Cheryl Pitts and all other interests.

Published with the authority of VicRoads.

Dated 26 June 2003

For and on behalf of VicRoads:
GERRY TURNER,
Manager Property Services Department.

comprising 3.149 hectares and being land described in Certificate of Title Volume 9412, Folio 911, shown as Parcel 113 on Survey Plan 20450.

Interest Acquired: That of Daniel Williamson and Ayrton Lynette Teed and all other interests.

Published with the authority of VicRoads.

Dated 26 June 2003

For and on behalf of VicRoads:
GERRY TURNER,
Manager Property Services Department.

Land Acquisition and Compensation Act 1986

FORM 7 S.21
Reg. 16

Notice of Acquisition

Compulsory Acquisition of Interest in Land

The Roads Corporation (VicRoads), declares that by this notice it acquires the following interest in the land described as part of Lots 1 and 2 on Plan of Subdivision 403095Q and Crown Allotments 10 and 10A, Section 2, Parish of Faraday comprising 6.4782 hectares and being land described in Certificate of Title Volume 10299, Folio 344; Certificate of Title Volume 10299, Folio 345; Crown Grant Volume 409, Folio 676; Crown Grant Volume 7695, Folio 085, shown as Parcels 109, 110, 111 and 112 on Survey Plan 20450.

Interest Acquired: That of Iris Howarth and all other interests.

Published with the authority of VicRoads.

Dated 26 June 2003

For and on behalf of VicRoads:
GERRY TURNER,
Manager Property Services Department.

Land Acquisition and Compensation Act 1986

FORM 7 S.21
Reg. 16

Notice of Acquisition

Compulsory Acquisition of Interest in Land

The Roads Corporation (VicRoads), declares that by this notice it acquires the following interest in the land described as part of Lot 2 on Plan of Subdivision 131714, Parish of Faraday

Land Acquisition and Compensation Act 1986

FORM 7 S.21
Reg. 16

Notice of Acquisition

Compulsory Acquisition of Interest in Land

The Roads Corporation (VicRoads), declares that by this notice it acquires the following interest in the land described as part of Lot 1 on Plan of Subdivision 63730, Crown Section 2, Parish of Faraday comprising 10.780 hectares and being land described in Certificate of Title Volume 9117, Folio 734, shown as Parcel 114 on Survey Plan 20450.

Interest Acquired: That of John Desmond Jones and all other interests.

Published with the authority of VicRoads.

Dated 26 June 2003

For and on behalf of VicRoads:
GERRY TURNER,
Manager Property Services Department.

Land Acquisition and Compensation Act 1986

FORM 7 S.21
Reg. 16

Notice of Acquisition

Compulsory Acquisition of Interest in Land

The Roads Corporation (VicRoads), declares that by this notice it acquires the following interest in the land described as part of Lot 1 on Plan of Subdivision 125600, Parish of Faraday comprising 1738.0 square metres and being land described in Certificate of Title Volume 9305, Folio 288, shown as Parcel 86 on Survey Plan 20449.

Interest Acquired: That of Patricia Noel Hayes-Johnson and all other interests.

Published with the authority of VicRoads.
Dated 26 June 2003

For and on behalf of VicRoads:
GERRY TURNER,
Manager Property Services Department.

Land Acquisition and Compensation Act 1986

FORM 7 S.21
Reg. 16

Notice of Acquisition

Compulsory Acquisition of Interest in Land

The Roads Corporation (VicRoads), declares that by this notice it acquires the following interest in the land described as part of Crown Allotment 36, Crown Section 6, Parish of Faraday comprising 2.474 hectares and being land described in Conveyance Book 816, No. 523, shown as Parcel 6 on Survey Plan 20445.

Interest Acquired: That of Raymond John & Beverley Lillian Patricia Charlton and all other interests.

Published with the authority of VicRoads.
Dated 26 June 2003

For and on behalf of VicRoads:
GERRY TURNER,
Manager Property Services Department.

Land Acquisition and Compensation Act 1986

FORM 7 S.21
Reg. 16

Notice of Acquisition

Compulsory Acquisition of Interest in Land

The Roads Corporation (VicRoads), declares that by this notice it acquires the following interest in the land described as part of Lots 1, 2 and 3 on Title Plan 587888H, Parish of Ravenswood comprising 10.535 hectares and being land described in Certificate of Title Volume 4017, Folio 323, shown as Parcel 105 on Survey Plan 20460 and Parcel 121 on Survey Plan 20461.

Interest Acquired: That of Oliver Aeneas Ernest Bickford and all other interests.

Published with the authority of VicRoads.
Dated 26 June 2003

For and on behalf of VicRoads:
GERRY TURNER,
Manager Property Services Department.

Land Acquisition and Compensation Act 1986

FORM 7 S.21
Reg. 16

Notice of Acquisition

Compulsory Acquisition of Interest in Land

The Roads Corporation (VicRoads), declares that by this notice it acquires the following interest in the land described as part of Crown Allotment 8F, Section 16, Parish of Ravenswood comprising 1.412 hectares and being land described in Certificate of Title Volume 6414, Folio 697, shown as Parcel 125 on Survey Plan 20461.

Interest Acquired: That of Bruce Martin Grant Bickford and all other interests.

Published with the authority of VicRoads.
Dated 26 June 2003

For and on behalf of VicRoads:
GERRY TURNER,
Manager Property Services Department.

Land Acquisition and Compensation Act 1986

FORM 7 S.21
Reg. 16

Notice of Acquisition

Compulsory Acquisition of Interest in Land

The Roads Corporation (VicRoads), declares that by this notice it acquires the following interest in the land described as part of Crown Section 16, Crown Allotments 5B, 6B, 7B and 8D, Parish of Ravenswood, comprising 23.67 hectares and being land described in Certificate of Title Volume 4453, Folio 408; Certificate of Title Volume 4006, Folio 169; Certificate of Title Volume 2985, Folio 959 shown as Parcels 141 and 142 on Survey Plan 20462 and Parcel 124 on Survey Plan 20461.

Interest Acquired: That of Donald Grant and Rosalie Jean Bickford and all other interests.

Published with the authority of VicRoads.
Dated 26 June 2003

For and on behalf of VicRoads:
GERRY TURNER,
Manager Property Services Department.

Land Acquisition and Compensation Act 1986

FORM 7 S.21
Reg. 16

Notice of Acquisition

Compulsory Acquisition of Interest in Land

The Roads Corporation (VicRoads), declares that by this notice it acquires the following interest in the land described as part of Crown Section 4, Parish of Faraday comprising 3.756 hectares and being land described in Certificate of Title Volume 10330, Folio 883, shown as Parcel 25 on Survey Plan 20446 and Parcel 25 on Survey Plan 20446.

Interest Acquired: That of Alan John and Heather May Elliot and all other interests.

Published with the authority of VicRoads.
Dated 26 June 2003

For and on behalf of VicRoads:
GERRY TURNER,
Manager Property Services Department.

Land Acquisition and Compensation Act 1986

FORM 7 S.21
Reg. 16

Notice of Acquisition

Compulsory Acquisition of Interest in Land

The Roads Corporation (VicRoads), declares that by this notice it acquires the following interest in the land described as part of Crown Allotments 8 and 9, Crown Section 4, Parish of Faraday comprising 8.349 hectares and being land described in Conveyance Book 692, No. 693, shown as Parcels 26 and 27 on Survey Plan 20446.

Interest Acquired: That of Charles Harold Ellery and all other interests.

Published with the authority of VicRoads.
Dated 26 June 2003

For and on behalf of VicRoads:
GERRY TURNER,
Manager Property Services Department.

Land Acquisition and Compensation Act 1986

FORM 7 S.21
Reg. 16

Notice of Acquisition

Compulsory Acquisition of Interest in Land

The Roads Corporation (VicRoads), declares that by this notice it acquires the following interest in the land described as part of Lot 1 on Title Plan 424329K, Parish of Ravenswood comprising 13.940 hectares and being land described in Certificate of Title Volume 8833, Folio 809; shown as Parcel 181 on Survey Plan 20464.

Interest Acquired: That of B. R. & P. A. Balmer and all other interests.

Published with the authority of VicRoads.
Dated 26 June 2003

For and on behalf of VicRoads:
GERRY TURNER,
Manager Property Services Department.

Land Acquisition and Compensation Act 1986

FORM 7 S.21
Reg. 16

Notice of Acquisition

Compulsory Acquisition of Interest in Land

The Roads Corporation (VicRoads), declares that by this notice it acquires the following interest in the land described as part of Lots 1, 2, 3 and 4 on Title Plan 112700J, Parish of Ravenswood comprising 10.945 hectares and being land described in Certificate of Title Volume 9571, Folio 777; Certificate of Title Volume 9571, Folio 778, shown as Parcels 102, 103 and 104 on Survey Plan 20460.

Interest Acquired: That of John Ernest Bickford and all other interests.

Published with the authority of VicRoads.
Dated 26 June 2003

For and on behalf of VicRoads:
GERRY TURNER,
Manager Property Services Department.

Land Acquisition and Compensation Act 1986

FORM 7 S.21
Reg. 16

Notice of Acquisition

Compulsory Acquisition of Interest in Land

The Roads Corporation (VicRoads), declares that by this notice it acquires the following

interest in the land described as part of Crown Allotment 3B, Section 2, part of Crown Allotment 4B, Section 16 and part of Crown Allotment 1B, Parish of Ravenswood comprising 24.278 hectares and being land described in Crown Grant Volume 1187, Folio 210; Certificate of Title Volume 601, Folio 029 and Certificate of Title Volume 7803, Folio 055 shown as Parcels 161 and 162 on Survey Plan 20463 and Parcel 144 on Survey Plan 20462.

Interest Acquired: That of Christopher John Comini and all other interests.

Published with the authority of VicRoads.

Dated 26 June 2003

For and on behalf of VicRoads:
GERRY TURNER,
Manager Property Services Department.

Land Act 1958

NOTICE OF INTENTION TO EXCHANGE LAND

I, Mary Delahunty, Minister for Planning, do hereby give notice that after the expiry of at least 14 days from the date of publication of this notice, I intend to enter into an agreement with the City of Frankston and St. Anthony's Coptic Orthodox College Inc. to exchange approximately 380 square metres of freehold land being part of Lot 403 on Plan of Subdivision 75223 as contained in Certificate of Title Volume 10156, Folio 863, for approximately 2305 square metres of Crown land comprising two portions of Crown Allotment 42J, Parish of Frankston.

Contact: P. Barber. Telephone 9296 4511.
Reference: PP-LA/32/0011.

MARY DELAHUNTY
Minister for Planning

Mineral Resources Development Act 1990

EXEMPTION FROM EXPLORATION LICENCE OR MINING LICENCE

I, Richard Aldous, Executive Director Minerals and Petroleum, pursuant to section 7 of the **Mineral Resources Development Act 1990** and under delegation by the Minister for Energy Industries and Resources –

1. HEREBY EXEMPT all that Crown land situated within the boundaries of exploration licence application 4748 that has been excised from the application, from being

subject to an exploration licence or mining licence.

2. Subject to paragraph 3, this exemption applies until the expiration of 2 years after the grant of the licence (if the licence is granted), or until the expiration of 28 days after the application lapses or is withdrawn or refused.
3. This exemption is REVOKED in respect of any land that ceases to lie within the boundaries of the application or licence, at the expiration of 28 days after the said land ceases to lie within the boundaries of the application or licence.

Dated 17 June 2003

RICHARD ALDOUS
Executive Director
Minerals and Petroleum

Penalty Interest Rate Act 1983

PENALTY INTEREST RATE

The penalty interest rate fixed by the Attorney-General under the **Penalty Interest Rate Act 1983**, commencing on 21 June 2003 is 11.25% per annum. The rate was previously fixed at 11%.

INTERIM CREDITING RATE — STATE SUPERANNUATION FUND

For the purposes of sub-sections 46(1) and 58(1) of the **State Superannuation Act 1988**, sub-section 35(1) of the **Transport Superannuation Act 1988** and sub-section 37(1) of the **State Employees Retirement Benefits Act 1979**, the Government Superannuation Office has determined an annual rate of 0.4% to be applied as an interim crediting rate on exits on or after 23 June 2003.

PETER J. WYATT
Chief Financial Officer

Pipelines Act 1967 (Vic.)

VARIATION OF THE LICENCE TO CONSTRUCT AND OPERATE A PIPELINE 63

Section 28A

I, the Minister for Resources for the State of Victoria, hereby give notice in accordance with the provisions of Section 28A of the **Pipelines Act 1967 (Vic.)**, that the Licence to Construct and Operate 63, granted to Esso Australia

Resources Pty Ltd of 12 Riverside Quay, Southbank, Vic. 3002 and BHP Billiton Petroleum (Bass Strait) Pty Ltd of 600 Bourke Street, Melbourne, Vic. 3000 is varied by:

The DELETION of reference to "a valve at Site 3 on Licensed pipeline 39"; and

the ADDITION of reference to "a valve at Site 2A on Licensed pipeline 39"; and

the ADDITION of Drawing Nos. 310-12501 Rev 1 dated 6 January 2000 and 000-12541 Rev 0 dated 16 August 1995.

Dated 17 June 2003

THEO THEOPHANOUS
Minister for Resources

Pipelines Act 1967 (Vic.)

VARIATION OF THE LICENCE TO
CONSTRUCT AND OPERATE
A PIPELINE 27

Section 28A

I, the Minister for Resources for the State of Victoria, hereby give notice in accordance with the provisions of Section 28A of the **Pipelines Act 1967** (Vic.), that the Licence to Construct and Operate 27, granted to Esso Australia Resources Pty Ltd of 12 Riverside Quay, Southbank, Vic. 3002 and BHP Billiton Petroleum (Bass Strait) Pty Ltd of 600 Bourke Street, Melbourne, Vic. 3000 is varied by:

The DELETION of part D of the Schedule:

Pressure Control

Unless otherwise approved in writing by the Minister the pressure in the pipeline shall not at any time exceed 8274 kPa.

and the ADDITION of Part D of the Schedule:

Pressure Control

Unless otherwise approved in writing by the Minister the pressure in the pipeline shall not at any time exceed 8274 kPa, with the exception of Westbury Pumping Station piping where the pressure in the piping between the pump isolation valves POV-L101 and POV-L141, as per drawings 394-12510 Rev 2 dated January 2002, shall not exceed 10210kPa.

Dated 17 June 2003

THEO THEOPHANOUS
Minister for Resources

Rail Corporations Act 1996

NOTICE UNDER SECTION 39(2A)

Minister for Transport

Pursuant to Section 39(2A) of the **Rail Corporations Act 1996** (the Act), I fix 31 March 2003 as the relevant date for the purposes of a document dated 27 March 2003 prepared under Section 57 of the Act listing an employee of the Public Transport Corporation that is to be regarded as having been employed by virtue of Section 58 of the Act with effect from the relevant date by Spencer Street Station Authority.

Dated 19 June 2003

PETER BATCHELOR MP
Minister for Transport

Rail Corporations Act 1996

NOTICE UNDER SECTION 39(2)

Minister for Transport

Pursuant to Section 39(2) of the **Rail Corporations Act 1996** (the Act), I do hereby fix 27 June 2003 as the relevant date for the purposes of an allocation statement dated 19 June 2003 made under Section 40(1) of the Act to transfer certain property to Victorian Rail Track Corporation.

Dated 19 June 2003

PETER BATCHELOR MP
Minister for Transport

Rail Corporations Act 1996

NOTICE UNDER SECTION 39(2)

Minister for Transport

Pursuant to Section 39(2) of the **Rail Corporations Act 1996** (the Act), I do hereby fix 27 June 2003 as the relevant date for the purposes of an allocation statement dated 19 June 2003 made under Section 40(1) of the Act to transfer certain property to Public Transport Ticketing Body.

Dated 19 June 2003

PETER BATCHELOR MP
Minister for Transport

Subordinate Legislation Act 1994

NOTICE OF PREPARATION OF REGULATORY IMPACT STATEMENT (RIS)

Surveyors (Fees) Regulations 2003

Notice is given that, in accordance with section 11 of the **Subordinate Legislation Act 1994**, a Regulatory Impact Statement (RIS) has been prepared in relation to the Surveyors (Fees) Regulations 2003.

The Surveyors (Fees) Regulations 2003 will replace the Surveyors (Fees) Regulations 1992 that sunset on 18 August 2003. The proposed Regulations prescribe fees payable to the Surveyors Board under the **Surveyors Act 1978**, prescribe allowances payable to members of the Board and prescribe remuneration for examiners under that Act.

The RIS discusses possible alternatives to the proposed Regulations and concludes that the proposed Regulations are the best means of achieving the stated objectives.

Copies of the RIS and the proposed Regulations may be obtained from the Customer Service Centre by phoning 136 186 (between 8.00 am and 8.00 pm weekdays), the Department's Information Centre, (Ground Floor, 8 Nicholson Street, East Melbourne 3002 between 8.30 am and 5.30 pm weekdays), or the internet at www.surveyorsboard.vic.gov.au/RIS.

Public comments are invited on the RIS and the accompanying Regulations. All comments must be in writing and must be received at the following address by 5.00 pm on 25 July 2003.

Ian Romeril, Executive Officer, Surveyors Board of Victoria, P.O. Box 500, East Melbourne 3002.

Telephone: (03) 8636 2555

Facsimile: (03) 8636 2588

Email: Ian.Romeril@surveyorsboard.vic.gov.au

Dated 19 June 2003

THE HON JOHN THWAITES, MP
Acting Minister for Planning

Medical Practice Act 1994

NOTICE

Re: Dr David Samuel Silberman

A Panel of the Medical Practitioners Board of Victoria on 19 June 2003 concluded a Formal Hearing into the professional conduct of Dr David Samuel Silberman, a registered medical practitioner

The Panel determined pursuant to section 50(1)(a) of the **Medical Practice Act 1994** ("the Act") that Dr Silberman had engaged in unprofessional conduct of a serious nature.

The Panel further determined pursuant to section 50(2)(h) of the Act that the medical registration of Dr Silberman be cancelled effective immediately.

Dated 19 June 2003

JOHN H. SMITH
Deputy CEO

Medical Practice Act 1994

FIXING OF FEES

Pursuant to section 96 of the **Medical Practice Act 1994** the Medical Practitioners Board of Victoria has fixed the following fees for a period of not less than 12 months commencing 1 July 2003.

1.	Registration Fees:	\$
	Application for:	
	General registration (section 7)	300.00

Specific registration (section 8)	
(i) in excess of six (6) months	300.00
(ii) six (6) months or less	150.00
Provisional registration (section 9)	175.00
Renewal of registration (section 13)	350.00
Amendment/variation of specific registration	
(i) in excess of six (6) months	350.00
(ii) six (6) months or less	175.00
Registration pursuant to the Mutual Recognition Act 1992 (C'th)	175.00
Restoration of name to the Register of Medical Practitioners pursuant to (section 14)	470.00
Additional renewal fee for application for renewal of registration received within three (3) months after 30 September 2003 (section 13(2))	120.00
2. Other Fees:	
Application for Certificate of Good Standing	50.00
Provision of a letter of confirmation of registration status, not being a Certificate of Good Standing	50.00
Fee for extracts/copies from the Register of Medical Practitioners (section 17(5))	
(i) Single extract	50.00
(ii) Multiple extracts (up to 20)	200.00
(iii) Copy of full Register	1,500.00
(iv) Copy of part of Register	750.00
Re-direction fee (GST inclusive)	25.00
Replacement student card (GST inclusive)	25.00

Dated 19 June 2003

J. M. FLYNN
President
Medical Practitioners Board of Victoria

Gas Industry Act 2001

NOTICE OF AMENDMENT UNDER SECTION 52(6)

Victorian Gas Industry Market and System Operation Rules ("MSO Rules")

Corrigendum

The following corrigendum is published in respect of the Notice amending the Victorian Gas Industry Market and System Operation Rules (MSO Rules) published in the Victorian Government Gazette G25 on 19 June 2001 at page 1447.

Replace the words:

“(ba) If the amount calculated in accordance with clause 3.6.6(b) is insufficient to satisfy the total amount of compensation payable by *VENCorp* to a *Market Participant* entitled to be paid under clause 6.6.5, then *VENCorp* shall be entitled to recover the outstanding balance of that payment from *Participants* in accordance with clauses 3.6.6(bb) and 3.6.6(bc).”

with the words:

“(ba) If the amount calculated in accordance with clause 3.6.6(b) is insufficient to satisfy the total amount of compensation payable by *VENCorp* to a *Participant* entitled to be paid under clause 6.6.5, then *VENCorp* shall be entitled to recover the outstanding balance of that payment from *Participants* in accordance with clauses 3.6.6(bb) and 3.6.6(bc).”

MATT ZEMA
Chief Executive Officer
VENCorp

Accident Compensation Act 1985**NOTICE OF INDEXED BENEFIT LEVELS AND OTHER AMOUNTS IN ACCORDANCE WITH SECTION 100 OF THE ACCIDENT COMPENSATION ACT 1985 AND REGULATION 20 OF THE ACCIDENT COMPENSATION REGULATIONS 2001**

Section 100 (1) of the **Accident Compensation Act 1985** stipulates that certain amounts in Part IV and in Section 5A of the Act are varied on 1 July each year in line with the movement in the average weekly earnings for all employees in Victoria between the two previous December quarters, using the latest figures published by the Australian Statistician as at 30 May following the previous December quarter. Weekly payments are indexed on the anniversary of the entitlement to weekly payments as detailed in Section 100(2) of the Act.

The average weekly earnings for all employees in Victoria between the December quarter of 2001 and the December quarter 2002 increased from \$663.20 to \$710.90 which is an increase of 7.2%.

Following legislative changes in December 1997 some amounts are indexed by the rise in Consumer Price Index. The Consumer Price Index between the December quarter of 2001 and the December quarter of 2002 increased from 134.8 to 139.0 which is an increase of 3.1%.

Section	Provision	Rate before 1 July 03	Rate from 1 July 03
COMPENSATION FOR DEATH OF A WORKER (CPI)			
Revised compensation for death of worker			
92A(4)	For a dependent partner or partners in equal shares	\$196,740	\$202,870
92A(5)	For an orphan child or orphan children in equal shares	\$196,740	\$202,870
92A(6)(a)	For a dependent partner(s) where there is one dependent child	\$177,070	\$182,590
92A(6)(b)	For the dependent child	\$19,680	\$20,290
92A(7)	For a dependent partner(s) where there are more than one dependent child but not more than 5 dependent children payable in the following shares: total amount of	\$196,740	\$202,870
92A(7)(a)	To each dependent child	\$9,830	\$10,140
92A(7)(b)	To partner/partners	Balance	Balance
92A(8)	For a dependent partner(s) where there are more than 5 dependent children payable in the following shares: total amount of	\$196,740	\$202,870
92A(8)(a)	To partner or partners in equal shares	\$147,560	\$152,160
92A(8)(b)	To the dependent children in equal shares	\$49,180	\$50,710
92A(8A)	Maximum lump sum for dependent children if no dependent partner	\$196,740	\$202,870
92A(9)	Maximum lump sum for any other dependants if no dependent partner or dependent child	\$196,740	\$202,870
WEEKLY PENSIONS FOR DEPENDANTS OF WORKER WHO DIES (AWE)			
During the first 13 weeks			
92B(3)(a)(ii)	Maximum weekly pension for a dependent partner	\$976	\$1,050
92B(4)(a)(ii)	Maximum weekly pension for 2 or more dependent partners in equal shares	\$976	\$1,050

Section	Provision	Rate before 1 July 03	Rate from 1 July 03
92B(5)(a)(ii)	Maximum weekly pension for one orphan child	\$976	\$1,050
92B(6)(a)(ii)	Maximum weekly pension for 2 or more orphan children in equal shares	\$976	\$1,050
	After first 13 weeks until the end of 3 years		
92B(3)(b)(i)	Maximum weekly pension for a dependent partner	\$976	\$1,050
92B(3)(b)(ii)	Weekly pension calculation for a dependent partner where there are not more than 5 dependent children and overall cap applies	\$976	\$1,050
92B(3)(b)(iii)	Weekly pension for a dependent partner where there are more than 5 dependent children and overall cap applies	\$652	\$699
92B(4)(b)(i)	Maximum weekly pension for 2 or more dependent partners in equal shares	\$976	\$1,050
92B(4)(b)(ii)	Weekly pension calculation for 2 or more dependent partners, where there are not more than 5 dependent children and overall cap applies	\$976	\$1,050
92B(4)(b)(iii)	Weekly pension for 2 or more dependent partners, where there are more than 5 dependent children and overall cap applies in equal shares	\$652	\$699
	After first 13 weeks until child ceases to be eligible		
92B(5)(b)(ii)	Maximum weekly pension for one orphan child	\$976	\$1,050
92B(6)(b)(ii)	Maximum weekly pension for 2 or more orphan children in equal shares	\$976	\$1,050
92B(7)(b)	Weekly pension calculation for each dependent child where there are not more than 5 dependent children and overall cap applies	\$976	\$1,050
92B(8)(b)	Weekly pension for dependent children where there are more than 5 dependent children and overall cap applies in equal shares	\$324	\$347
92B(11)	Total amount of weekly pensions	\$976	\$1,050
	WEEKLY PAYMENTS (AWE)		
	First 26 weeks incapacity		
	Where worker has no current work capacity		
93A(2)(a)(ii)	Maximum weekly payment	\$781	\$837
	Where worker has a current work capacity		
93A(2)(b)(ii)	Maximum weekly payments - less notional earnings	\$781	\$837
	After 26 weeks incapacity		
	Worker has a serious injury		
93B(1)(a)(ii)	Maximum weekly payment is – less 90% of notional earnings	\$781	\$837
	Worker does not have a serious injury but has no current work capacity		
93B(1)(b)(ii)	Maximum weekly payments	\$781	\$837

Section	Provision	Rate before 1 July 03	Rate from 1 July 03
	Worker does not have a serious injury but has a current work capacity		
93B(1)(c)(ii)	Maximum weekly payment is – less 60% of notional earnings	\$468	\$502
	GRANDFATHER PROVISIONS (AWE)		
93C(5)(c)(iii)	Minimum earnings for a worker who has a current work capacity after 104 weeks of payments as specified in Section 93CD(3)(a)	\$114	\$122
93C(11)(b)(iii)	Minimum earnings for a worker who has a current work capacity after 104 weeks of payments as specified in Section 93CD(3)(a)	\$114	\$122
	WEEKLY PAYMENTS (AWE)		
	Weekly payments for First Entitlement Period (first 13 weeks)		
93CA(2)(a)(ii)	Maximum weekly payment where worker has no current work capacity	\$976	\$1,050
93CA(2)(b)(ii)	Maximum weekly payment where worker has a current work capacity – less notional earnings	\$976	\$1,050
	Weekly payments for Second Entitlement Period (14-104 weeks)		
93CB(2)(a)(ii)	Maximum weekly payment where worker has no current work capacity	\$976	\$1,050
93CB(2)(b)(ii)	Maximum weekly payment where worker has a current work capacity – less 60% of notional earnings	\$585	\$627
	Weekly payment after the expiry of the second entitlement period		
93CC(2)(b)	Maximum weekly payment where worker has been assessed as having no current work capacity and likely to continue indefinitely to have no current work capacity	\$976	\$1,050
93CD(3)(a)	Minimum earnings for a worker who has returned to work	\$114	\$122
93CD(5)(b)	Maximum weekly payment where Authority or self-insurer has made a determination – less 60% of worker's current weekly earnings	\$585	\$627
	COMPENSATION FOR NON-ECONOMIC LOSS (CPI)		
	Permanent Impairment – Calculations of Amounts of Non-economic Loss		
98C(2)(b)	Where worker's degree of impairment is not less than 10% and not more than 30%	\$11,240 \$2,250	\$11,590 \$2,320
98C(2)(c)	Where worker's degree of impairment is more than 30% and not more than 70%	\$56,210 \$3,510	\$57,960 \$3,620
98C(2)(d)	Where worker's degree of impairment is more than 70% and not more than 80%	\$196,800 \$14,060	\$202,930 \$14,500

Section	Provision	Rate before 1 July 03	Rate from 1 July 03
98C(2)(e)	Where worker's degree of impairment is more than 80%	\$337,380	\$347,890
	Psychiatric Impairment – Calculations of Amounts of Non-economic Loss		
98C(3)(b)	Where worker's degree of impairment is not less than 30% and not more than 50%	\$11,240 \$3,660	\$11,590 \$3,770
98C(3)(c)	Where worker's degree of impairment is more than 50% and not more than 70%	\$84,370 \$5,620	\$87,000 \$5,800
98C(3)(d)	Where worker's degree of impairment is more than 70% and not more than 80%	\$196,800 \$14,060	\$202,930 \$14,500
98C(3)(e)	Where worker's degree of impairment is more than 80%	\$337,380	\$347,890
	Other non-economic loss		
98C(4)	Loss of a foetus or loss of more than one foetus	\$50,540	\$52,110
98C(7)	Maximum amount of compensation for more than one injury suffered on the same occasion	\$337,380	\$347,890
98C(8)	Maximum amount of compensation for more than one kind of non-economic loss for the same injury	\$337,380	\$347,890
NO DISADVANTAGE - COMPENSATION TABLE (AWE)			
98E	Total loss of the sight of both eyes	\$185,350	\$198,680
	Total loss of the sight of an only eye	\$185,350	\$198,680
	Loss of both hands	\$185,350	\$198,680
	Loss of both feet	\$185,350	\$198,680
	Loss of a hand and a foot	\$185,350	\$198,680
	Total loss of the right arm or of the greater part of the right arm	\$148,280	\$158,940
	Total loss of the left arm or of the greater part of the left arm	\$139,000	\$149,000
	Total loss of the right hand or of five fingers of the right hand, or of the lower part of the right arm	\$129,730	\$139,060
	Total loss of the left hand or of five fingers of the left hand, or of the lower part of the left arm	\$120,480	\$129,150
	Total loss of a leg	\$139,000	\$149,000
	Total loss of a foot	\$120,480	\$129,150
	Total loss of the lower part of the leg	\$129,730	\$139,060
	Total loss of the sight of one eye, together with the serious diminution of the sight of the other eye	\$139,000	\$149,000
	Total loss of hearing	\$120,480	\$129,150
	Total loss of the sight of one eye	\$74,140	\$79,470

Section	Provision	Rate before 1 July 03	Rate from 1 July 03
	Loss of binocular vision	\$74,140	\$79,470
	Loss of eyeball (in addition to compensation for loss of sight of an eye)	\$40,780	\$43,710
	Total loss of power of speech	\$111,210	\$119,210
	Total loss of sense of taste or smell	\$31,510	\$33,780
	Total loss of senses of both taste and smell	\$63,020	\$67,550
	Total loss of male sexual organs	\$87,120	\$93,390
	Total loss of penis	\$87,120	\$93,390
	Total loss of one testicle	\$18,520	\$19,850
	Total loss of two testicles or an only testicle	\$87,120	\$93,390
	Total loss of female sexual organs	\$87,120	\$93,390
	Total loss of both breasts	\$87,120	\$93,390
	Total loss of one breast	\$55,590	\$59,590
	Total loss of the thumb of the right hand	\$55,590	\$59,590
	Total loss of the thumb of the left hand	\$48,190	\$51,660
	Total loss of the forefinger of the right hand	\$38,930	\$41,730
	Total loss of the forefinger of the left hand	\$33,350	\$35,750
	Total loss of two joints of the forefinger of the right hand	\$29,650	\$31,780
	Total loss of two joints of the forefinger of the left hand	\$22,230	\$23,830
	Total loss of a joint of the thumb	\$29,650	\$31,780
	Total loss of the first joint of the forefinger of the right hand	\$18,520	\$19,850
	Total loss of the first joint of the forefinger of the left hand	\$16,690	\$17,890
	Total loss of the first joint of the middle or little or ring finger of either hand	\$11,120	\$11,920
	Total loss of the middle finger of either hand	\$22,230	\$23,830
	Total loss of the little or ring finger of either hand	\$20,390	\$21,860
	Total loss of two joints of the middle finger of either hand	\$18,520	\$19,850
	Total loss of two joints of the little or ring finger of either hand	\$16,690	\$17,890
	Total loss of the great toe of either foot	\$40,780	\$43,710
	Total loss of a joint of the great toe of either foot	\$18,520	\$19,850
	Total loss of any other toe	\$11,120	\$11,920
	Total loss of a joint of any other toe	\$3,710	\$3,980
	Quadriplegia	\$185,350	\$198,680
	Paraplegia	\$185,350	\$198,680
	Total impairment of the spine	\$185,350	\$198,680
98E(5)	Maximum total amount of compensation allowable under 98E Table	\$185,350	\$198,680

Section	Provision	Rate before 1 July 03	Rate from 1 July 03
MEDICAL AND LIKE SERVICES (CPI)			
99(1)(aa)	Maximum Family Counselling expenses	\$1,770	\$1,830
99(5)	Employer's Liability	\$480	\$495
125(1)(a)(iii)	Employer's initial liability for medical and like services	\$480	\$495
125A(3)(c)	Employer's initial liability for medical and like services	\$480	\$495
LIABILITY OF PRIOR INSURER (AWE)			
129B (7)	Minimum payments for contribution injury	\$9,720	\$10,420
ACTIONS FOR DAMAGE			
Pecuniary Loss (AWE)			
134AB(22)(a)(i)	Threshold	\$38,670	\$41,450
134AB(22)(a)(ii)	Maximum	\$870,400	\$933,000
Pain and Suffering (AWE)			
134AB(22)(b)(i)	Threshold	\$37,340	\$40,030
134AB(22)(b)(ii)	Maximum	\$378,950	\$406,210
Pecuniary Loss (AWE)			
135A(7)(a)(i)	Threshold	\$38,670	\$41,450
135A(7)(a)(ii)	Maximum	\$870,400	\$933,000
Pain and Suffering (CPI)			
135A(7)(b)(i)	Threshold	\$37,850	\$39,030
135A(7)(b)(ii)	Maximum	\$384,100	\$396,070
Damages under Part III of the Wrongs Act 1958 (AWE)			
135C(2)	Death of a person	\$574,200	\$615,500
PRE-INJURY AVERAGE WEEKLY EARNINGS (AWE)			
5A (8)	Where no rate applicable	\$976	\$1,050
5A(9)(b)	Deemed Pre-injury Average Weekly Earnings for a full-time student at time of completion of course	\$976	\$1,050
5A(11)(b)	Deemed Pre-injury Average Weekly earnings for a full-time student at a primary or secondary school at time of completion of secondary school	\$781	\$837
MAXIMUM ASSESSMENT FEE FOR APPLICATION FOR APPROVAL AS A SELF-INSURER (AWE)			
Regulation 20	Maximum assessment fee	\$35,830	\$38,410

Workers Compensation Act 1958NOTICE OF NEW BENEFIT RATES PAYABLE IN ACCORDANCE WITH
SECTION 9 AND SECTION 11

- (a) Section 9(3) of the **Workers Compensation Act 1958** provides for rates of compensation to be adjusted on 1 July in any year in line with movements in the Australian male average weekly earnings between the December quarter of the two preceeding years as published by the Australian Statistician at 15 June in each respective year.

The Australian male average weekly earnings for the December quarter of 2001 and 2002 were \$811.50 and \$847.50 respectively, an increase of 4.4%.

Notice is hereby given that calculations in accordance with the said section produce the following rates of compensation which are payable, on and from 1 July 2003 instead of the amounts specified in Section 9 of the said Act, in the clauses under the heading "The Clauses Referred To".

The amount specified in "The Clauses Referred To" (wherever occurring)		Rates before 1 July 03	Rates from 1 July 03
COMPENSATION FOR THE DEATH OF A WORKER			
	Amount as per the 1958 Act		
1(a) (i)	\$33,160	\$125,915	\$131,501
	\$8,088	\$30,717	\$32,080
	\$7,566	\$28,727	\$30,001
	\$7,044	\$26,747	\$27,934
	\$6,523	\$24,768	\$25,867
	\$6,001	\$22,785	\$23,796
	\$5,479	\$20,803	\$21,726
	\$4,957	\$18,822	\$19,657
	\$4,435	\$16,840	\$17,587
	\$3,914	\$14,863	\$15,522
	\$3,392	\$12,877	\$13,448
	\$2,870	\$10,897	\$11,380
	\$2,348	\$8,913	\$9,308
	\$1,826	\$6,933	\$7,241
	\$1,826	\$6,933	\$7,241
1(a)(ii)	\$33,160	\$125,915	\$131,501
WEEKLY PAYMENTS			
1(b) (i)	\$105	\$401	\$419
	\$30	\$112	\$117
	\$10	\$38	\$40
	\$155	\$591	\$617
	\$78	\$295	\$308
	\$135	\$509	\$532
TOTAL LIABILITY FOR WEEKLY PAYMENTS			
1(b) (iii)	\$36,960	\$140,345	\$146,571

- (b) Section 11(1) of the **Workers Compensation Act 1958** provides for rates of compensation for certain specified injuries to be set percentages of the maximum payable, at the time of the injury, under Clause 1(a)(ii).

Occupational Health and Safety Act 1985
VICTORIAN WORKCOVER AUTHORITY

Notice of Issue of Major Hazard Licence

On 27 May 2003, a licence under Part 8 of the Occupational Health and Safety (Major Hazard Facilities) Regulations 2000 was issued to Westchem Pty Ltd, 13–19 Maria Street, Laverton North and authorises the facility located at 13–19 Maria Street, Laverton North to be operated as a major hazard facility.

The Major Hazard Facility Licence was issued for a term of 5 years and will expire on 28 April 2008.

The licence did not include conditions.

The following Schedule 1 materials were authorised by the licence:

From Table 1 of Schedule 1

Material	UN Nos included under name
AMMONIUM NITRATE FERTILISERS	2067, 2068, 2069, 2070
AMMONIUM NITRATE, with not more than 0.2 per cent combustible substances, including any organic substance calculated as carbon, to the exclusion of any other added substance	1942
DIPHENYLMETHANE 4,4'-DIISOCYANATE	2489
FORMALDEHYDE	1198, 2209
HYDROFLUORIC ACID SOLUTION (greater than 50 per cent)	1790
SODIUM CHLORATE, solid	1495
TOLUENE DIISOCYANATE	2078

From Table 2 of Schedule 1

Material	Description
Compressed and liquefied gases	Compressed or liquefied gases of Class 2.1 or Subsidiary Risk 2.1
Flammable materials	Liquids which meet the criteria for Class 3 Packing Group I Materials (except for crude oil in remote locations)
Flammable materials	Liquids which meet the criteria for Class 3 Packing Group II or III
Flammable materials	Materials which meet the criteria for Class 4.1 Packing Group I
Flammable materials	Spontaneously combustible materials which meet the criteria for Class 4.2 Packing Group I or II
Flammable materials	Materials which liberate flammable gases or react violently on contact with water which meet the criteria for Class 4.3 Packing Group I or II

From Table 2 of Schedule 1 (continued)

Material	Description
Flammable materials	Materials which belong to Classes 3 or 8 Packing Group I or II which have Hazchem codes of 4WE (materials which react violently with water)
Oxidising Materials	Oxidising materials that meet the criteria for Class 5.1 Packing Group I or II
Peroxides	Organic Peroxides which meet the criteria for Class 5.2
Toxic Solids and liquids (other than materials which are classified as Infectious Substances (Class 6.2) or as Radioactive (Class 7))	Materials which meet the criteria for Toxic in Table 3

GREG TWEEDLY
Chief Executive

Occupational Health and Safety Act 1985
VICTORIAN WORKCOVER AUTHORITY

Notice of Issue of Major Hazard Licence

On 15 April 2003, a licence under Part 8 of the Occupational Health and Safety (Major Hazard Facilities) Regulations 2000 was issued to Orica Australia Pty Ltd, 1 Nicholson Street, Melbourne, Victoria and authorises the facility located at 166–180 Dohertys Road, Laverton North to be operated as a major hazard facility.

The Major Hazard Facility Licence was issued for a term of 5 years and will expire on 10 March 2008.

The licence did not include conditions.

The following Schedule 1 materials were authorised by the licence:

From Table 1 of Schedule 1

Material	UN Nos included under name
AMMONIA, ANHYDROUS	1005
CHLORINE	1017
HYDROGEN (in process gas)	1049
HYDROGEN CHLORIDE (in process gas)	1050

From Table 2 of Schedule 1

Material	Description
Nil	Nil

GREG TWEEDLY
Chief Executive

Occupational Health and Safety Act 1985
VICTORIAN WORKCOVER AUTHORITY

Notice of Issue of Major Hazard Licence

On 13 June 2003, a licence under Part 8 of the Occupational Health and Safety (Major Hazard Facilities) Regulations 2000 was issued to Dow Chemical (Australia) Ltd, 541–583 Kororoit Creek Road, Altona, Victoria and authorises the facility located at 541–583 Kororoit Creek Road, Altona to be operated as a major hazard facility.

The Major Hazard Facility Licence was issued for a term of 5 years and will expire on 30 April 2008.

The licence did not include conditions.

The following Schedule 1 materials were authorised by the licence:

From Table 1 of Schedule 1

Material	UN Nos included under name
ACRYLONITRILE	1093
DIPHENYLMETHANE 4.4' – DIISOCYANATE (MDI)	2489
ETHYLENE OXIDE	1040
NATURAL GAS (in process gas)	1971
PROPYLENE OXIDE	1280
TOLUENE DIISOCYANATE (TDI)	2078

From Table 2 of Schedule 1

Material	Description
Compressed and liquefied gases	Compressed or liquefied gases of Class 2.1 or Subsidiary Risk 2.1
Flammable materials	Liquids which meet the criteria for Class 3 Packaging Group II or III
Oxidising Materials	Oxidising materials that meet the criteria for Class 5.1 Packaging Group II or III
Peroxides	Organic Peroxides which meet the criteria for Class 5.2

GREG TWEEDLY
 Chief Executive

Occupational Health and Safety Act 1985
VICTORIAN WORKCOVER AUTHORITY

Notice of Issue of Major Hazard Licence

On 11 June 2003, a licence under Part 8 of the Occupational Health and Safety (Major Hazard Facilities) Regulations 2000 was issued to FBT Operations (Vic.) Pty Ltd, 1 Amanda Road, Tottenham, Victoria and authorises the facility located at 1 Amanda Road, Tottenham to be operated as a major hazard facility.

The Major Hazard Facility Licence was issued for a term of 5 years and will expire on 19 May 2008.

The licence did not include conditions.

The following Schedule 1 materials were authorised by the licence:

From Table 1 of Schedule 1

Material	UN Nos included under name
ACRYLONITRILE	1093
AMMONIUM NITRATE, with not more than 0.2 per cent combustible substances, including any organic substance calculated as carbon, to the exclusion of any other added substance	1942
ARSENIC TRIOXIDE, Arsenious (III) Acid and other salts	1561
BROMINE or BROMINE SOLUTIONS	1744
CHLORINE	1017
ETHYLENE OXIDE	1040
FORMALDEHYDE	1198, 2209
HYDROFLUORIC ACID SOLUTION (greater than 50 per cent)	1790
HYDROGEN FLUORIDE	1052
LP GASES	1011, 1012, 1075, 1077, 1978
METHANE or NATURAL GAS	1971, 1972
PROPYLENE OXIDE	1280
SODIUM CHLORATE, solid	1495
SULFUR DIOXIDE, LIQUEFIED	1079
TOLUENE DIISOCYANATE	2078

From Table 2 of Schedule 1

Material	Description
Compressed and liquefied gases	Compressed or liquefied gases of Class 2.1 or Subsidiary Risk 2.1
Chlorine (UN1017), a Compressed and liquefied gas	A Compressed or liquefied gas which meets the criteria for Very Toxic in Table 3
Compressed and liquefied gases	Compressed or liquefied gases which meet the criteria for Toxic in Table 3
Flammable materials	Liquids which meet the criteria for Class 3 Packing Group I
Flammable materials	Liquids which meet the criteria for Class 3 Packing Group II or III
Flammable materials	Spontaneously combustible materials which meet the criteria for Class 4.2 Packing Group I or II
Flammable materials	Materials which liberate flammable gases or react violently on contact with water which meet the criteria for Class 4.3 Packing Group I or II
Oxidising Materials	Oxidising materials which meet the criteria for Class 5.1 Packing Group I or II
Toxic Solids and liquids	Materials which meet the criteria for Toxic in Table 3

GREG TWEEDLY
Chief Executive

Occupational Health and Safety Act 1985
VICTORIAN WORKCOVER AUTHORITY
Notice of Issue of Major Hazard Licence

On 11 June 2003, a licence under Part 8 of the Occupational Health and Safety (Major Hazard Facilities) Regulations 2000 was issued to Huntsman Chemical Company Australia Pty Ltd, Somerville Road, West Footscray, Victoria and authorises the facility located at Somerville Road, West Footscray to be operated as a major hazard facility.

The Major Hazard Facility Licence was issued for a term of 3 years and will expire on 11 May 2006.

The following conditions are attached to the licence:

1. That Huntsman implement all components of its technical integrity audit program outlined in its letter of 8 May 2003; to the satisfaction of the Authority.
2. That Huntsman incorporates the findings of the technical integrity audit program in its risk reduction action plans for:
 - a) the phenol and phenolic resins plants, by 31 December 2003;
 - b) the ethylene, litol, offsites, alkylation, distillation, dehydrogenation, styrene tankfarm, polyester resins, polystyrene, tankfarm and boilerhouse utilities plants, by 30 June 2004;
 to the satisfaction of the Authority.

The following Schedule 1 materials were authorised by the licence:

From Table 1 of Schedule 1

Material	UN Nos included under name
ACETYLENE (in process gas)	1001
AMMONIA	1005
CHLORINE	1017
FORMALDEHYDE	2209
HYDROGEN (in process gas)	1049
HYDROGEN SULPHIDE	1053
METHANE (in process gas)	1971
OXYGEN	1072
PROPYLENE OXIDE	1280

From Table 2 of Schedule 1

Material	Description
Compressed and liquefied gases	Compressed or liquefied gases of Class 2.1 or Subsidiary Risk 2.1
Flammable materials	Liquids which meet the criteria for Class 3 Packing Group I Materials (except for crude oil in remote locations)
Flammable materials	Liquids which meet the criteria for Class 3 Packing Group II or III
Flammable materials	Liquids with flashpoints < 61° C kept above their boiling points at ambient conditions
Peroxides	Organic Peroxides which meet the criteria for Class 5.2
Phenol (UN 1671 & 2312)	A solid or liquid material which meets the criteria for Very Toxic in Table 3

GREG TWEEDLY
Chief Executive

Occupational Health and Safety Act 1985
VICTORIAN WORKCOVER AUTHORITY
Notice of Issue of Major Hazard Licence

On 22 May 2003, a licence under Part 8 of the Occupational Health and Safety (Major Hazard Facilities) Regulations 2000 was issued to Wesfarmers Kleenheat Gas Pty Ltd, corner of Mt. Derrimut & Tilburn Roads, Deer Park, Victoria and authorises the facility located at Shepherd Road, Swan Hill, Victoria to be operated as a major hazard facility.

The Major Hazard Facility Licence was issued for a term of 5 years and will expire on 16 April 2008.

The licence did not include conditions.

The following Schedule 1 materials were authorised by the licence:

From Table 1 of Schedule 1

Material	UN Nos included under name
LP GASES	1075

From Table 2 of Schedule 1

Material	Description
Nil	Nil

GREG TWEEDLY
Chief Executive

Occupational Health and Safety Act 1985

VICTORIAN WORKCOVER AUTHORITY

Notice of Issue of Major Hazard Licence

On 5 June 2003, a licence under Part 8 of the Occupational Health and Safety (Major Hazard Facilities) Regulations 2000 was issued to Shell Refining (Australia) Pty Ltd of Refinery Road, Corio, Victoria and authorises the facility located at Refinery Road, Corio to be operated as a major hazard facility.

The Major Hazard Facility Licence was issued for a term of 5 years and will expire on 13 May 2008.

The following condition is attached to the licence:

1. That by 31 December each year, Shell demonstrates to the satisfaction of the Authority that its control measures continue to be effective to eliminate, or if it is not practicable to eliminate, to reduce so far as is practicable, risk to health and safety as defined in Regulation 304(2). In particular, Shell must demonstrate that its asset integrity programs are responding to causative factors and trends identified in its incident trend analysis at a level that is to the satisfaction of the Authority.

The following Schedule 1 materials were authorised by the licence:

From Table 1 of Schedule 1

Material	UN Nos included under name
AMMONIA	1005
HYDROGEN (in process gas)	1049
HYDROGEN FLUORIDE	1052
HYDROGEN SULPHIDE (in process gas)	1053
LP GASES	1011, 1012, 1075, 1077, 1978
METHANE or NATURAL GAS (in process gas)	1971

From Table 2 of Schedule 1

Material	Description
Compressed and liquefied gases	Compressed or liquefied gases of Class 2.1 or Subsidiary Risk 2.1
Flammable materials	Liquids which meet the criteria for Class 3 Packing Group I (except for crude oil in remote locations)
Flammable materials	Liquids which meet the criteria for Class 3 Packing Group II or III
Toxic Solids and liquids	A Material which meets the criteria for Toxic in Table 3

GREG TWEEDLY
Chief Executive

Occupational Health and Safety Act 1985
VICTORIAN WORKCOVER AUTHORITY
Notice of Issue of Major Hazard Licence

On 29 May 2003, a licence under Part 8 of the Occupational Health and Safety (Major Hazard Facilities) Regulations 2000 was issued to Borden Chemical Australia Pty Ltd, 2-8 James Street, Laverton North, Victoria and authorises the facility located at 2-8 James Street, Laverton North to be operated as a major hazard facility.

The Major Hazard Facility Licence was issued for a term of 5 years and will expire on 26 March 2008.

The licence did not include conditions.

The following Schedule 1 materials were authorised by the licence:

From Table 1 of Schedule 1

Material	UN Nos included under name
AMMONIA	1005
FORMALDEHYDE SOLUTION	2209

From Table 2 of Schedule 1

Material	Description
Flammable materials	Liquids which meet the criteria for Class 3 Packing Group I
Flammable materials	Liquids which meet the criteria for Class 3 Packing Group II or III
Phenol (UN 2312) a Very Toxic Solid and liquid	A Material which meets the criteria for Very Toxic in Table 3

GREG TWEEDLY
Chief Executive

Occupational Health and Safety Act 1985
VICTORIAN WORKCOVER AUTHORITY

Notice of Issue of Major Hazard Licence

On 19 June 2003, a licence under Part 8 of the Occupational Health and Safety (Major Hazard Facilities) Regulations 2000 was issued to Westgate Logistics Pty Ltd, Level 4, 650 Lorimer Street, Port Melbourne, Victoria and authorises the facility located at 16–24 Berends Drive, Dandenong South, to be operated as a major hazard facility.

The Major Hazard Facility Licence was issued for a term of 5 years and will expire on 18 May 2008.

The licence did not include conditions.

The following Schedule 1 materials were authorised by the licence:

From Table 1 of Schedule 1

Material	UN Nos included under name
TOLUENE DIISOCYANATE	2078

From Table 2 of Schedule 1

Material	Description
Compressed and liquefied gases	Compressed or liquefied gases of Class 2.1 or Subsidiary Risk 2.1
Flammable materials	Liquids which meet the criteria for Class 3 Packing Group II or III
Flammable materials	Materials which belong to Classes 3 or 8 Packing Group I or II which have Hazchem codes of 4WE (materials which react violently with water)
Oxidising materials	Oxidising Materials that meet the criteria for Class 5.1 Packing Group I or II
Toxic solids and liquids	Materials which meet the criteria for Toxic in Table 3

GREG TWEEDLY
 Chief Executive

Water Industry Act 1994

INSTRUMENT FIXING THE MINIMUM AMOUNT OF RATE TO BE PAID IN RESPECT OF ANY LAND

I, John Thwaites, Minister for Environment and Minister responsible for administering the **Water Industry Act 1994**, under section 139(4) of the **Water Industry Act 1994**, fix the minimum amount of rate to be paid in respect of any land in respect of the 2003–2004 financial year to be \$46.70.

Dated 18 June 2003

JOHN THWAITES MP
 Minister for Environment

Melbourne City Link Act 1995

NOTICE UNDER SECTION 71(1)

Under section 71(1)(b) of the **Melbourne City Link Act 1995** ("the Act"), City Link Extension Pty Limited ABN 40 082 058 615 (the relevant corporation in relation to the Extension road) hereby fixes tolls which are payable in respect of the use of vehicles on the toll zone on the Extension road where those vehicles are the subject of a CityLink Pass for that use.

For the purposes of this Notice, the following definitions apply:

Bus is a Motor Vehicle having more than 12 seating positions (including that of the driver);

Car is a Motor Vehicle, other than a Motor Cycle, a Light Commercial Vehicle, a Heavy Commercial Vehicle or a Taxi even if such a Motor Vehicle is towing a trailer or caravan;

CityLink is CityLink Melbourne Limited ABN 65 070 810 678, the relevant corporation for the purposes of section 73C of the Act;

CityLink Pass is a 24 Hour Pass or a Weekend Pass;

Full Link road is the road included within both the Link road and the Extension road;

Heavy Commercial Vehicle or **HCV** is a Motor Vehicle, other than a Taxi, which is:

- (a) a rigid Truck with three or more axles;
- (b) an articulated Truck;
- (c) a Bus; or
- (d) a two axle rigid Truck having a gross vehicle mass which exceeds 4.5 tonnes;

Light Commercial Vehicle or **LCV** is a Motor Vehicle, other than a Taxi, which is a two axle rigid Truck having a gross vehicle mass which exceeds 1.5 tonnes, but does not exceed 4.5 tonnes;

Motor Cycle is a two wheeled Motor Vehicle (and includes such a Motor Vehicle even if it has a trailer, fore car or side car attached) other than a Taxi;

Motor Vehicle is a vehicle which is used or intended to be used on a highway or in a public place and which has its own motive power (other than human or animal power) but does not include:

- (a) a vehicle intended to be used on a railway or tramway; or
- (b) a motorised wheel chair capable of a speed of not more than 10 kilometres per hour which is used solely for the conveyance of an injured or disabled person;

Taxi is, at any particular time, a Motor Vehicle in relation to which a commercial passenger vehicle licence (issued under the **Transport Act 1983**) then subsists, being a licence allowing for the operation of the Motor Vehicle as a Taxi-Cab (within the meaning of the **Transport Act 1983**);

the Extension Agreement has the same meaning as in the Act;

the Integration and Facilitation Agreement has the same meaning as in the Act;

Trip is the passage of a vehicle on one or more toll zones:

- (a) uninterrupted by exit and subsequent re-entry; or
- (b) if so interrupted, consists only of travel directly between:
 - (i) that part of the Link road between Bulla Road and the West Gate Freeway; and
 - (ii) that part of the Link road between Sturt Street and Glenferrie Road;

Truck is a Motor Vehicle other than a Bus which has a cab-chassis construction and a gross vehicle mass which exceeds 1.5 tonnes;

24 Hour Pass is an agreement with CityLink to exempt a vehicle (other than a Taxi) from the requirement to be registered under Part 4 of the Act for use of any or all toll zones comprising the Full Link road for a fixed 24 hour period commencing at the time of the first Trip by the vehicle on a specified day;

vehicle has the same meaning as in the Act; and

Weekend Pass is an agreement with CityLink to exempt a Car or Light Commercial Vehicle from the requirement to be registered under Part 4 of the Act for use of any or all toll zones comprising the Full Link road for a fixed period commencing at 12.00 pm on the Friday immediately before a specified Saturday and ending at midnight on the Sunday immediately following that specified Saturday. The fact that CityLink also exempts that Car or Light Commercial Vehicle for an additional period at no extra charge does not prevent the agreement from being a Weekend Pass.

Under section 71(1)(b) of the Act and in accordance with the Extension Agreement, the tolls listed in Table One are payable in respect of the use of vehicles on the toll zone on the Extension road where the vehicle is the subject of a 24 Hour Pass for that use.

Table One			
24 Hour Pass	Toll		
	Car	LCV	HCV
	\$9.30	\$14.90	\$17.75

Under section 71(1)(b) of the Act and in accordance with the Extension Agreement, the tolls listed in Table Two are payable in respect of the use of vehicles on the toll zone on the Extension road where the vehicle is the subject of a Weekend Pass for that use.

Table Two		
Weekend Pass	Toll	
	Car	LCV
	\$9.30	\$14.90

For the avoidance of doubt, this Notice does not set Charge Tolls or Day Tolls for the purpose of Schedule 1 (the Toll Calculation Schedule) of the Extension Agreement or Schedule 4 (the Toll Calculation Schedule) of the Integration and Facilitation Agreement.

For the avoidance of doubt, this Notice also:

- (i) revokes or repeals; or, in the alternative
- (ii) amends –

the NOTICE UNDER SECTION 71(1) dated 21 March 2003 and published in the Victoria Government Gazette No. G 13 (pages 607 to 609), dated 27 March 2003 (“the Last Notice”).

This Notice takes effect on 1 July 2003, and for the avoidance of doubt, the Last Notice ceases to have effect when this Notice takes effect, and the revocation, repeal, amendment or ceasing to have effect of the Last Notice shall not:

- (a) revive anything not in force or existing at the time at which the revocation, repeal, amendment or ceasing to have effect becomes operative;
- (b) affect the previous operation of the Last Notice or anything duly done or suffered under the Last Notice;
- (c) affect any right, privilege, obligation or liability acquired, accrued or incurred under the Last Notice;
- (d) affect any penalty, forfeiture or punishment incurred in respect of any offence committed relating (directly or indirectly) to or in respect of the Last Notice; or
- (e) affect any investigation, legal proceeding or remedy in respect of any such right, privilege, obligation, liability, penalty, forfeiture or punishment as is mentioned in paragraphs (c) and (d) –

and any such investigation, legal proceeding or remedy may be instituted, continued or enforced, and any such penalty, forfeiture or punishment may be imposed, as if the Last Notice had not been revoked or repealed or amended or had not expired, lapsed or otherwise ceased to have effect.

For the avoidance of doubt, the revocation, repeal, amendment or ceasing to have effect of the Last Notice does not in any way affect the direct amendments made in or by the Last Notice to, or the operation or effect of those amendments to, any NOTICE UNDER SECTION 71(1) published in the Victoria Government Gazette prior to the publication of the Last Notice.

Dated 23 June 2003

The common seal of
CITY LINK EXTENSION PTY LIMITED
is fixed to this document by:

A. K. CARNEGIE
Company Secretary
City Link Extension Pty Limited
(ABN 40 082 058 615)

K. EDWARDS
Director
City Link Extension Pty Limited
(ABN 40 082 058 615)

Melbourne City Link Act 1995

NOTICE UNDER SECTION 71(1)

Under section 71(1)(b) of the **Melbourne City Link Act 1995** (“the Act”), CityLink Melbourne Limited ABN 65 070 810 678 (the relevant corporation in relation to the Link road) (“CityLink Melbourne”) hereby fixes tolls which are payable in respect of the use of vehicles on toll zones on the Link road where those vehicles are the subject of a CityLink Pass for that use.

For the purposes of this Notice, the following definitions apply:

Bus is a Motor Vehicle having more than 12 seating positions (including that of the driver);

Car is a Motor Vehicle, other than a Motor Cycle, a Light Commercial Vehicle, a Heavy Commercial Vehicle or a Taxi even if such a Motor Vehicle is towing a trailer or caravan;

CityLink Pass is a 24 Hour Pass, a Tulla Pass or a Weekend Pass;

Full Link road is the road included within both the Link road and the Extension road;

Heavy Commercial Vehicle or **HCV** is a Motor Vehicle, other than a Taxi, which is:

- (a) a rigid Truck with three or more axles;
- (b) an articulated Truck;
- (c) a Bus; or
- (d) a two axle rigid Truck having a gross vehicle mass which exceeds 4.5 tonnes;

Light Commercial Vehicle or **LCV** is a Motor Vehicle, other than a Taxi, which is a two axle rigid Truck having a gross vehicle mass which exceeds 1.5 tonnes, but does not exceed 4.5 tonnes;

Motor Cycle is a two wheeled Motor Vehicle (and includes such a Motor Vehicle even if it has a trailer, fore car or side car attached) other than a Taxi;

Motor Vehicle is a vehicle which is used or intended to be used on a highway or in a public place and which has its own motive power (other than human or animal power) but does not include:

- (a) a vehicle intended to be used on a railway or tramway; or
- (b) a motorised wheel chair capable of a speed of not more than 10 kilometres per hour which is used solely for the conveyance of an injured or disabled person;

Taxi is, at any particular time, a Motor Vehicle in relation to which a commercial passenger vehicle licence (issued under the **Transport Act 1983**) then subsists, being a licence allowing for the operation of the Motor Vehicle as a Taxi-Cab (within the meaning of the **Transport Act 1983**);

the Agreement has the same meaning as in the Act;

the Integration and Facilitation Agreement has the same meaning as in the Act;

Trip is the passage of a vehicle on one or more toll zones:

- (a) uninterrupted by exit and subsequent re-entry; or
- (b) if so interrupted, consists only of travel directly between:
 - (i) that part of the Link road between Bulla Road and the West Gate Freeway; and
 - (ii) that part of the Link road between Sturt Street and Glenferrie Road

Truck is a Motor Vehicle other than a Bus which has a cab-chassis construction and a gross vehicle mass which exceeds 1.5 tonnes;

Tulla Pass is an agreement with CityLink Melbourne for CityLink Melbourne to exempt a Car or Light Commercial Vehicle from the requirement to be registered under Part 4 of the Act for use only on that part of the Link road being the Tullamarine Freeway Upgrade, between Bulla Road and Flemington Road including the toll zone between Moreland Road and Brunswick Road, for a fixed 24 hour period commencing at the time of the first Tulla Trip by that Car or Light Commercial Vehicle on a specified day;

Tulla Trip is the passage of a Car or Light Commercial Vehicle on that part of the Link road being the toll zone between Moreland Road and Brunswick Road;

24 Hour Pass is an agreement with CityLink Melbourne to exempt a vehicle (other than a Taxi) from the requirement to be registered under Part 4 of the Act for use of any or all toll zones comprising the Full Link road for a fixed 24 hour period commencing at the time of the first Trip by the vehicle on a specified day;

vehicle has the same meaning as in the Act; and

Weekend Pass is an agreement with CityLink Melbourne to exempt a Car or Light Commercial Vehicle from the requirement to be registered under Part 4 of the Act for use of any or all toll zones comprising the Full Link road for a fixed period commencing at 12.00 pm on the Friday immediately before a specified Saturday and ending at midnight on the Sunday immediately following that specified Saturday. The fact that CityLink Melbourne also exempts a Car or Light Commercial Vehicle for an additional period at no extra charge does not prevent the agreement from being a Weekend Pass.

Under section 71(1)(b) of the Act and in accordance with the Agreement, the tolls listed in Table One are payable in respect of the use of vehicles on toll zones on the Link road where the vehicle is the subject of a 24 Hour Pass for that use.

Table One			
24 Hour Pass	Toll		
	Car	LCV	HCV
	\$9.30	\$14.90	\$17.75

Under section 71(1)(b) of the Act and in accordance with the Agreement, the tolls listed in Table Two are payable in respect of the use of vehicles on toll zones on the Link road where the vehicle is the subject of a Weekend Pass for that use.

Table Two		
Weekend Pass	Toll	
	Car	LCV
	\$9.30	\$14.90

Under section 71(1)(b) of the Act and in accordance with the Agreement, the tolls listed in Table Three are payable in respect of the use of Cars or Light Commercial Vehicles on the toll zone, consisting of that part of the Link road between Moreland Road and Brunswick Road, where the Car or Light Commercial Vehicle is the subject of a Tulla Pass for that use.

Table Three		
Tulla Pass	Toll	
	Car	LCV
	\$ 3.30	\$ 5.30

For the avoidance of doubt, this Notice does not set Charge Tolls or Day Tolls for the purpose of Schedule 3 (the Toll Calculation Schedule) of the Agreement or Schedule 4 (the Toll Calculation Schedule) of the Integration and Facilitation Agreement.

For the avoidance of doubt, this Notice also:

- (i) revokes or repeals; or, in the alternative
- (ii) amends –

the NOTICE UNDER SECTION 71(1) dated 21 March 2003 and published in the Victoria Government Gazette No. G 13 (599 to 601), dated 27 March 2003 (“the Last Notice”).

This Notice takes effect on 1 July 2003, and for the avoidance of doubt, the Last Notice ceases to have effect when this Notice takes effect, and the revocation, repeal, amendment or ceasing to have effect of the Last Notice shall not:

- (a) revive anything not in force or existing at the time at which the revocation, repeal, amendment or ceasing to have effect becomes operative;
- (b) affect the previous operation of the Last Notice or anything duly done or suffered under the Last Notice;
- (c) affect any right, privilege, obligation or liability acquired, accrued or incurred under the Last Notice;
- (d) affect any penalty, forfeiture or punishment incurred in respect of any offence committed relating (directly or indirectly) to or in respect of the Last Notice; or
- (e) affect any investigation, legal proceeding or remedy in respect of any such right, privilege, obligation, liability, penalty, forfeiture or punishment as is mentioned in paragraphs (c) and (d) -

and any such investigation, legal proceeding or remedy may be instituted, continued or enforced, and any such penalty, forfeiture or punishment may be imposed, as if the Last Notice had not been revoked or repealed or amended or had not expired, lapsed or otherwise ceased to have effect.

For the avoidance of doubt, the revocation, repeal, amendment or ceasing to have effect of the Last Notice does not in any way affect the direct amendments made in or by the Last Notice to, or the operation or effect of those amendments to, any NOTICE UNDER SECTION 71(1) published in the Victoria Government Gazette prior to the publication of the Last Notice.

Dated 23 June 2003

The common seal of

CITYLINK MELBOURNE LIMITED

is fixed to this document by:

A K CARNEGIE
Company Secretary
CityLink Melbourne Limited
(ABN 65 070 810 678)

K EDWARDS
Director
CityLink Melbourne Limited
(ABN 65 070 810 678)

Melbourne City Link Act 1995

NOTICE UNDER SECTION 71(1)

Under section 71(1)(b) of the **Melbourne City Link Act 1995** ("the Act"), City Link Extension Pty Limited ABN 40 082 058 615 (the relevant corporation in relation to the Extension road) hereby fixes tolls which are payable in respect of the use of vehicles (as set out herein) on the toll zone on the Extension road.

For the purposes of this Notice, the following definitions apply:

Bus is a Motor Vehicle having more than 12 seating positions (including that of the driver);

Car is a Motor Vehicle, other than:

- (a) a Motor Cycle;
- (b) a Light Commercial Vehicle;
- (c) a Heavy Commercial Vehicle; or
- (d) a Taxi;

even if such a Motor Vehicle is towing a trailer or caravan;

Heavy Commercial Vehicle or **HCV** is a Motor Vehicle, other than a Taxi, which is:

- (a) a rigid Truck with three or more axles;
- (b) an articulated Truck;
- (c) a Bus; or
- (d) a two axle rigid Truck having a gross vehicle mass which exceeds 4.5 tonnes;

Light Commercial Vehicle or **LCV** is a Motor Vehicle, other than a Taxi, which is a two axle rigid Truck having a gross vehicle mass which exceeds 1.5 tonnes, but does not exceed 4.5 tonnes;

Motor Cycle is a two wheeled Motor Vehicle (and includes such a Motor Vehicle even if it has a trailer, fore car or side car attached) other than a Taxi;

Motor Vehicle is a vehicle which is used or intended to be used on a highway or in a public place and which has its own motive power (other than human or animal power) but does not include:

- (a) a vehicle intended to be used on a railway or tramway; or
- (b) a motorised wheel chair capable of a speed of not more than 10 kilometres per hour which is used solely for the conveyance of an injured or disabled person;

Taxi is, at any particular time, a Motor Vehicle in relation to which a commercial passenger vehicle licence (issued under the **Transport Act 1983**) then subsists, being a licence allowing for the operation of the Motor Vehicle as a Taxi-Cab (within the meaning of the **Transport Act 1983**);

the Extension Agreement has the same meaning as in the Act;

the Integration and Facilitation Agreement has the same meaning as in the Act;

Truck is a Motor Vehicle other than a Bus which has a cab-chassis construction and a gross vehicle mass which exceeds 1.5 tonnes; and

vehicle has the same meaning as in the Act.

Under section 71(1)(b) of the Act and in accordance with the Extension Agreement, the tolls listed in Table One are payable in respect of the use of vehicles on the toll zone on the Extension road, where those vehicles are a Car, a LCV or a HCV:

Table One			
Toll Zone	Toll		
	Car	LCV	HCV
12. The Extension road	0.81	1.30	1.54

For the avoidance of doubt, this Notice does not set Charge Tolls for the purposes of Schedule 1 (the Toll Calculation Schedule) of the Extension Agreement, or Schedule 4 (the Toll Calculation Schedule) of the Integration and Facilitation Agreement.

For the avoidance of doubt, this Notice also:

- (i) revokes or repeals; or, in the alternative
- (ii) amends –

the NOTICE UNDER SECTION 71(1) dated 21 March 2003 and published in the Victoria Government Gazette No. G 13 (pages 610 to 611), dated 27 March 2003 (“the Last Notice”).

This Notice takes effect on 1 July 2003, and for the avoidance of doubt, the Last Notice ceases to have effect when this Notice takes effect, and the revocation, repeal, amendment or ceasing to have effect of the Last Notice shall not:

- (a) revive anything not in force or existing at the time at which the revocation, repeal, amendment or ceasing to have effect becomes operative;
- (b) affect the previous operation of the Last Notice or anything duly done or suffered under the Last Notice;
- (c) affect any right, privilege, obligation or liability acquired, accrued or incurred under the Last Notice;
- (d) affect any penalty, forfeiture or punishment incurred in respect of any offence committed relating (directly or indirectly) to or in respect of the Last Notice; or
- (e) affect any investigation, legal proceeding or remedy in respect of any such right, privilege, obligation, liability, penalty, forfeiture or punishment as is mentioned in paragraphs (c) and (d) –

and any such investigation, legal proceeding or remedy may be instituted, continued or enforced, and any such penalty, forfeiture or punishment may be imposed, as if the Last Notice had not been revoked or repealed or amended or had not expired, lapsed or otherwise ceased to have effect.

For the avoidance of doubt, the revocation, repeal, amendment or ceasing to have effect of the Last Notice does not in any way affect the direct amendments made in or by the Last Notice to, or the operation or effect of those amendments to, any NOTICE UNDER SECTION 71(1) published in the Victoria Government Gazette prior to the publication of the Last Notice.

Dated 23 June 2003

The common seal of
CITY LINK EXTENSION PTY LIMITED
is fixed to this document by:

A K CARNEGIE
Company Secretary
City Link Extension Pty Limited
(ABN 40 082 058 615)

K EDWARDS
Director
City Link Extension Pty Limited
(ABN 40 082 058 615)

Melbourne City Link Act 1995

NOTICE UNDER SECTION 71(1)

Under section 71(1)(b) of the **Melbourne City Link Act 1995** ("the Act"), CityLink Melbourne Limited ABN 65 070 810 678 (the relevant corporation in relation to the Link road) hereby fixes tolls which are payable in respect of the use of vehicles (as set out herein) on toll zones on the Link road.

For the purposes of this Notice, the following definitions apply:

Boulton Parade includes the off-ramp connecting the rest of the Link road to Boulton Parade;

Burnley Tunnel means the eastbound tunnel between Sturt Street and Burnley Street;

Bus is a Motor Vehicle having more than 12 seating positions (including that of the driver);

Car is a Motor Vehicle, other than:

- (a) a Motor Cycle;
- (b) a Light Commercial Vehicle;
- (c) a Heavy Commercial Vehicle; or
- (d) a Taxi;

even if such a Motor Vehicle is towing a trailer or caravan;

Domain Tunnel means the westbound tunnel between Punt Road and Sturt Street;

Full Link road is the road included within both the Link road and the Extension road;

Full Link Taxi Trip is a Trip by a Taxi on:

- (a) one or more of the toll zones described in this Notice as toll zones 1, 2 and 3; and
- (b) one or more of the toll zones described in this Notice as toll zones 4, 5, 6, 7, 8, 9, 10 and 11;

Half Link Taxi Trip is a Trip by a Taxi on:

- (a) one or more of the toll zones described in this Notice as toll zones 1, 2 and 3; or
- (b) one or more of the toll zones described in this Notice as toll zones 4, 5, 6, 7, 8, 9, 10 and 11,

and no other toll zone;

Heavy Commercial Vehicle or **HCV** is a Motor Vehicle, other than a Taxi, which is:

- (a) a rigid Truck with three or more axles;
- (b) an articulated Truck;
- (c) a Bus; or
- (d) a two axle rigid Truck having a gross vehicle mass which exceeds 4.5 tonnes;

Light Commercial Vehicle or **LCV** is a Motor Vehicle, other than a Taxi, which is a two axle rigid Truck having a gross vehicle mass which exceeds 1.5 tonnes, but does not exceed 4.5 tonnes;

Motor Cycle is a two wheeled Motor Vehicle (and includes such a Motor Vehicle even if it has a trailer, fore car or side car attached) other than a Taxi;

Motor Vehicle is a vehicle which is used or intended to be used on a highway or in a public place and which has its own motive power (other than human or animal power) but does not include:

- (a) a vehicle intended to be used on a railway or tramway; or
- (b) a motorised wheel chair capable of a speed of not more than 10 kilometres per hour which is used solely for the conveyance of an injured or disabled person;

Swan Street Intersection means the intersection between Swan Street and Batman Avenue;

Taxi is, at any particular time, a Motor Vehicle in relation to which a commercial passenger vehicle licence (issued under the **Transport Act 1983**) then subsists, being a licence allowing for the operation of the Motor Vehicle as a Taxi-Cab (within the meaning of the **Transport Act 1983**);

the Agreement has the same meaning as in the Act;

the Integration and Facilitation Agreement has the same meaning as in the Act;

Trip is the passage of a vehicle on one or more toll zones:

- (a) uninterrupted by exit and subsequent re-entry; or
- (b) if so interrupted, the interruption consists only of travel directly between:
 - (i) that part of the Link road between Bulla Road and the West Gate Freeway; and
 - (ii) that part of the Link road between Sturt Street and Glenferrie Road;

Truck is a Motor Vehicle other than a Bus which has a cab-chassis construction and a gross vehicle mass which exceeds 1.5 tonnes; and

vehicle has the same meaning as in the Act.

Under section 71(1)(b) of the Act and in accordance with the Agreement, the tolls listed in Table One are payable in respect of the use of vehicles on toll zones on the Link road, where those vehicles are a Car, a LCV or a HCV:

Table One			
Toll Zone	Toll		
	Car	LCV	HCV
1. That part of the Link road between Moreland Road and Brunswick Road.	1.30	2.08	2.47
2. That part of the Link road between Racecourse Road and Dynon Road.	1.30	2.08	2.47
3. That part of the Link road between Footscray Road and the West Gate Freeway.	1.62	2.60	3.08
4. That part of the Link road being the Domain Tunnel and that part of the Link road leading into that Tunnel between the eastern portal of that Tunnel and Punt Road, other than that part of the Link road – (a) being the eastbound carriageways of the Link road; (b) between Punt Road and the exit to Boulton Parade; and (c) comprising Boulton Parade.	1.62	2.60	3.08
5. That part of the Link road being the Burnley Tunnel and that part of the Link road leading out of that Tunnel between the eastern portal of that Tunnel and Burnley Street.	2.92	4.67	5.55
6. That part of the Link road being the eastbound carriageways between Punt Road and Burnley Street other than that part of the Link road being the Burnley Tunnel and that part of the Link road leading out of that Tunnel between the eastern portal of that Tunnel and Burnley Street.	1.30	2.08	2.47

<p>7. That part of the Link road between Burnley Street and Punt Road and including that part of the Link road –</p> <p>(a) between Punt Road and the exit to Boulton Parade, other than the eastbound carriageways; and</p> <p>(b) comprising Boulton Parade, other than:</p> <p>(i) the eastbound carriageways between Burnley Street and Punt Road; and</p> <p>(ii) that part of the Link road being the Burnley Tunnel and that part of the Link road leading out of that Tunnel between the eastern portal of that Tunnel and Burnley Street.</p>	1.30	2.08	2.47
<p>8. That part of the Link road being the eastbound carriageways between Burnley Street and Glenferrie Road.</p>	1.30	2.08	2.47
<p>9. That part of the Link road between Glenferrie Road and Burnley Street, other than the eastbound carriageways.</p>	1.30	2.08	2.47
<p>10. That part of the Link road being the eastbound carriageways between Swan Street Intersection and Punt Road, other than –</p> <p>(a) that part of the Link road being the Burnley Tunnel; and</p> <p>(b) that part of the Link road comprising Boulton Parade.</p>	0.81	1.30	1.54
<p>11. That part of the Link road between Punt Road and Swan Street Intersection, other than–</p> <p>(a) the eastbound carriageways;</p> <p>(b) that part of the Link road being the Burnley Tunnel;</p> <p>(c) that part of the Link road:</p> <p>(1) between Punt Road and the exit to Boulton Parade; and</p> <p>(2) comprising Boulton Parade; and</p> <p>(d) that part of the Link road being the Domain Tunnel and that part of the Link road leading into that Tunnel between the eastern portal of that Tunnel and Punt Road.</p>	0.81	1.30	1.54

For the avoidance of doubt, a reference in this Notice to the specification of a toll zone by reference to Burnley Street refers to that point on the Link road where Burnley Street would cross the Link road if Burnley Street continued in a straight southerly direction from its southernmost extremity. For the avoidance of doubt, a reference in this Notice to "eastbound" means in a general easterly direction from the eastern end of the West Gate Freeway towards Glenferrie Road.

Notwithstanding anything to the contrary in Table One, under section 71(1) (b) of the Act and in accordance with the Agreement, the maximum tolls payable in respect of the use of a vehicle on a toll zone on the Link road where that vehicle is a Car, a LCV or a HCV for a Trip are as listed in Table Two:

Table Two			
Trip Cap	Toll		
	Car	LCV	HCV
1. Where the passage of the vehicle on the last toll zone comprising the Trip before exiting the Full Link road occurs between 6 am and 8 pm on the same day.	4.87	6.49	6.49
2. Where the passage of the vehicle on the last toll zone comprising the Trip before exiting the Full Link road occurs between 8 pm on the one day and 6 am on the next.	4.87	4.87	4.87

Under Section 71(1)(b) of the Act, and in accordance with the Agreement, the tolls listed in Table Three are payable in respect of the use of vehicles on toll zones on the Link road where those vehicles are Taxis:

Table Three	
Taxis	Toll
Each Half Link Taxi Trip	2.20
Each Full Link Taxi Trip	3.85

For the avoidance of doubt, this Notice does not set Charge Tolls, Maximum Charge Tolls or Taxi Tolls for the purposes of Schedule 3 (the Toll Calculation Schedule) of the Agreement, or Schedule 4 (the Toll Calculation Schedule) of the Integration and Facilitation Agreement.

For the avoidance of doubt, this Notice also:

- (i) revokes or repeals; or, in the alternative
- (ii) amends –

the NOTICE UNDER SECTION 71(1) dated 21 March 2003 and published in the Victoria Government Gazette No. G 13 (pages 602 to 606), dated 27 March 2003 ("the Last Notice").

This notice takes effect on 1 July 2003 and for the avoidance of doubt, the Last Notice ceases to have effect when this Notice takes effect, and the revocation, repeal, amendment or ceasing to have effect of the Last Notice shall not:

- (a) revive anything not in force or existing at the time at which the revocation, repeal, amendment or ceasing to have effect becomes operative;
- (b) affect the previous operation of the Last Notice or anything duly done or suffered under the Last Notice;

- (c) affect any right, privilege, obligation or liability acquired, accrued or incurred under the Last Notice;
- (d) affect any penalty, forfeiture or punishment incurred in respect of any offence committed relating (directly or indirectly) to or in respect of the Last Notice; or
- (e) affect any investigation, legal proceeding or remedy in respect of any such right, privilege, obligation, liability, penalty, forfeiture or punishment as is mentioned in paragraphs (c) and (d) –

and any such investigation, legal proceeding or remedy may be instituted, continued or enforced, and any such penalty, forfeiture or punishment may be imposed, as if the Last Notice had not been revoked or repealed or amended or had not expired, lapsed or otherwise ceased to have effect.

For the avoidance of doubt, the revocation, repeal, amendment or ceasing to have effect of the Last Notice does not in any way affect the direct amendments made in or by the Last Notice to, or the operation or effect of those amendments to, any NOTICE UNDER SECTION 71(1) published in the Victoria Government Gazette prior to the publication of the Last Notice.

Dated 23 June 2003

The common seal of
CITYLINK MELBOURNE LIMITED
is fixed to this document by:

A K CARNEGIE
Company Secretary
CityLink Melbourne Limited
(ABN 65 070 810 678)

K EDWARDS
Director
CityLink Melbourne Limited
(ABN 65 070 810 678)



PUBLIC COMMENT INVITED

Otway Gas Project

Environment Effects Statement/Environmental
Impact StatementNotice of Preparation of Amendment C2
Corangamite Planning SchemeEPA Works Approval
Application No. WA 52899

The proponent, Woodside Energy Ltd (Woodside), proposes to develop gas resources in the Thylacine and Geographe gas fields located in the offshore Otway Basin approximately 70km and 55km respectively south of Port Campbell, off the Victorian Coast. The proposed Otway Gas Project will involve:

- the drilling and operation of several production wells supported by either surface or subsea collection facilities at the two gas fields;
- construction and operation of an offshore pipeline between the Thylacine gas field and the south western Victorian coast, with a sub-surface shore crossing at the Port Campbell Rifle Range, near Port Campbell;
- construction and operation of a buried high pressure onshore pipeline from the shore crossing point to a gas plant;
- construction and operation of a gas processing plant and associated infrastructure located in Waarre Road, Waarre, approximately 6km from Port Campbell.

The project will require separate planning, environmental, pipeline and other approvals under Commonwealth and Victorian legislation. The two governments have agreed to a coordinated environmental assessment process for the project including the preparation of an integrated environment assessment document (Environment Effects Statement/Environmental Impact Statement or EES/EIS) to satisfy the requirements of each jurisdiction.

The Part 3, Division 1 controlling provisions under the **Environment Protection and Biodiversity Conservation Act 1999** (EPBC Act) are:

- Sections 18 and 18A (Listed threatened species and communities); and
- Sections 20 and 20A (Listed migratory species); and
- Sections 23 and 24A (Marine environment).

The Part 3, Division 2, controlling provisions are:

- Sections 26 and 27A (Protection of the environment from actions involving Commonwealth land).

The Minister for Planning has prepared Amendment C2 to the Corangamite Planning Scheme.

The land affected by the Amendment is Waarre Road, Port Campbell comprising land within Certificates of Title Volume 6238, Folio 564; Volume 10677, Folio 854 and Volume 7717, Folio 167. The Amendment rezones the land from part Rural Zone and part Special Use Zone Schedule 1 (Waarre Road, Port Campbell – Gas Processing Plant) to Special Use Zone Schedule 4 (Waarre Road, Port Campbell, Woodside Gas Processing Plant). The Amendment also amends the Municipal Strategic Statement to refer to the importance of gas processing plants and storage facilities within the Corangamite Shire.

The following documents relating to the project have been placed on public exhibition as indicated.

- EES/EIS – An integrated document to meet the respective environmental and planning assessment requirements of Victorian and Commonwealth legislation has been prepared by the project proponent. (Cth/Vic);
- Amendment C2 to the Corangamite Planning Scheme, including documents that support the Amendment and the explanatory report about the Amendment;
- an EPA Works Approval Application No. WA 52899 – For the onshore gas processing plant and onsite bulk storage of propane, autogas and condensate (jointly advertised pursuant to Section 20AA of the **Environment Protection Act 1970**).

An Onshore Pipeline Permit Application under the **Pipelines Act 1967** is being advertised concurrently with the EES/EIS and EPA Works Approval Application (Vic only).

The documents are available for public inspection from 26 June 2003 until 29 August 2003 and may be examined during normal business hours at the following locations:

VICTORIA

- Department of Sustainability and Environment, Planning Information Centre, Nauru House, Upper Plaza, 80 Collins Street, Melbourne;
- Department of Sustainability and Environment (South Western Region), 180 Fyans Street, South Geelong;
- Department of Sustainability and Environment (Colac), 83 Gellibrand Street, Colac;
- Department of Sustainability and Environment (Warrnambool), 78 Henna Street, Warrnambool;
- Environment Protection Authority (Information Centre), Ground Floor, Herald & Weekly Times Tower, Southbank;
- Environment Protection Authority (South-West Region), corner of Little Malop and Fenwick Streets, Geelong;
- Mineral Resources Tasmania, 30 Gordons Hill Road, Rosny Park, Tasmania;
- State Library, 328 Swanston Street, Melbourne;
- Corangamite Shire, 181 Manifold Street, Camperdown;
- Warrnambool City Council, 25 Liebig Street, Warrnambool;
- Warrnambool Library, Liebig Street, Warrnambool;
- Port Campbell Visitor Information Centre, 26 Morris Street, Port Campbell;
- Moyne Shire, Princes Street, Port Fairy;
- Camperdown Library, 212 Manifold Street, Camperdown;
- Cobden Library, Victoria Street, Cobden;
- Colac Library, 99 Gellibrand Street, Colac;
- Corangamite Shire Mobile Library, (Contact Council on 5226 4825 for dates and times in your area);
- Timboon Library, 82 Curdie Vale Road, Timboon.

ACT

- Environment Australia Library, John Gorton Building, King Edward Terrace, Parkes, ACT.

The EES/EIS can also be viewed on the following websites: www.doi.vic.gov.au, www.woodside.com.au, and www.otway.woodside.com.au.

The Planning Scheme Amendment can be viewed at www.doi.vic.gov.au/planning.

Copies of the EES/EIS Summary document are available for free at all display locations in Victoria and from Woodside Energy Ltd. A CD-ROM version of the full document is available free of charge from Woodside.

Copies of the EES/EIS may be purchased from Woodside Energy Ltd ('toll free' telephone 1800 678 151). The cost of documentation is \$30 for the EES/EIS (Main Document and Technical Reports).

Copies of the Works Approval Application may be purchased for \$10 from the EPA offices listed above.

Public submissions – Victoria

Interested persons and organisations wishing to comment on the EES/EIS, Planning Scheme Amendment C2 and Works Approval Application WA 52899 are invited to make written submissions by 5 pm, 29 August 2003.

Submissions will be treated as public documents. Any submission lodged in relation to the EES/EIS, Planning Scheme Amendment and Works Approval Application will be considered as a submission on the Pipeline Permit Application. Following the public exhibition and receipt of submissions it is anticipated that a panel inquiry will be convened at which persons may be heard in respect of their submissions. The Panel will be appointed under the **Environment Effects Act 1978** and the **Planning and Environment Act 1987** and may also be appointed under the **Pipelines Act 1967**. Persons or organisations lodging submissions should state whether or not they wish to be heard at the inquiry hearings.

Submissions should be forwarded to: Mr Adrian Williams, Co-ordinator Panels Victoria, Department of Sustainability and Environment, Level 11, 80 Collins Street, Melbourne, Vic. 3000. Telephone: (03) 9655 8742. Fax: (03) 9655 8740.

Email: adrian.williams@doi.vic.gov.au

Copies of all submissions received will be forwarded to Woodside Energy Ltd, Environment Australia, Department of Sustainability and Environment, EPA, and the Department of Primary Industries.

Planning and Environment Act 1987
MANNINGHAM PLANNING SCHEME

Notice of Approval of Amendment
Amendment C14

The Minister for Planning has approved Amendment C14 to the Manningham Planning Scheme.

The Amendment comes into operation on the date this notice is published in the Government Gazette.

The Amendment corrects a number of mapping and typographical errors that have been identified within the new format Manningham Planning Scheme since it came into operation on 29 June 2000.

A copy of the Amendment can be inspected, free of charge, during office hours, at the Department of Sustainability and Environment, Planning Information Centre, Upper Plaza, Nauru House, 80 Collins Street, Melbourne and at the offices of the Manningham City Council, Municipal Offices, 699 Doncaster Road, Doncaster.

PAUL JEROME
General Manager
Planning, Land and
Environment Regulation
Department of Sustainability
and Environment

Planning and Environment Act 1987
MOIRA PLANNING SCHEME

Notice of Approval of Amendment
Amendment C12

The Minister for Planning has approved Amendment C12 to the Moira Planning Scheme.

The Amendment comes into operation on the date this notice is published in the Government Gazette.

The Amendment:

- rezones land adjacent to the south of Barooga Road, Cobram from Public Conservation and Resource Zone to Road Zone Category 1 to facilitate the construction of an approach to the new river crossing for Barooga Road over the Murray River;

- amends the Schedule to Clause 44.03 (Floodway Overlay) to provide that works or earthworks associated with the construction of the new crossing of the Murray River does not require a planning permit;
- amends the Schedule to Clause 52.17 (Native Vegetation) to provide that the removal, destruction or lopping of native vegetation does not require a planning permit in the Road Zone Category 1.

A copy of the Amendment can be inspected, free of charge, during office hours, at the Department of Sustainability and Environment, Customer Service Centre, Upper Plaza, Nauru House, 80 Collins Street, Melbourne; Department of Sustainability and Environment North-eastern Regional Office, 50–52 Clarke Street, Benalla, and at the offices of Moira Shire Council, 44 Station Street, Cobram.

PAUL JEROME
General Manager
Planning, Land and
Environment Regulation
Department of Sustainability
and Environment

Planning and Environment Act 1987
MORELAND PLANNING SCHEME

Notice of Approval of Amendment
Amendment C25

The Minister for Planning has approved Amendment C25 to the Moreland Planning Scheme.

The Amendment comes into operation on the date this notice is published in the Government Gazette.

The Amendment rezones land at 13–17 Duggan Street, Brunswick West (Certificates of Title Volume 8858, Folio 652; Volume 8997, Folio 826; Volume 6537, Folio 222; Volume 6207, Folio 343) from Industrial 3 Zone to Mixed Use Zone; replaces the Schedule to the Mixed Use Zone; applies the Environmental Audit Overlay and Incorporated Plan Overlay to the site; and updates the list of incorporated documents to include an Incorporated Plan, prepared in accordance with the requirements of the Incorporated Plan Overlay.

A copy of the Amendment can be inspected, free of charge, during office hours, at the Department of Sustainability and Environment, Planning Information Centre, Upper Plaza, Nauru House, 80 Collins Street, Melbourne and at the offices of the Moreland City Council, 90 Bell Street, Coburg.

PAUL JEROME
General Manager
Planning, Land and
Environment Regulation
Department of Sustainability
and Environment

Planning and Environment Act 1987

WODONGA PLANNING SCHEME

Notice of Approval of Amendment

Amendment C18

The Minister for Planning has approved Amendment C18 to the Wodonga Planning Scheme.

The Amendment comes into operation on the date this notice is published in the Government Gazette.

The Amendment rezones 69 hectares of land located on the north western corner of Baranduda Boulevard and Boyes Road, Baranduda from a Rural Zone to a Business 1 Zone and 68 hectares of land from a Business 1 Zone to a Rural Zone on land bounded by the Kiewa Valley Highway, Baranduda Boulevard, Boyes Road and John Boyes Drive, Baranduda.

A copy of the Amendment can be inspected, free of charge, during office hours, at the Department of Sustainability and Environment, Planning Information Centre, Upper Plaza, Nauru House, 80 Collins Street, Melbourne; the North Eastern Regional Office, 50–52 Clarke Street, Benalla and at the offices of the Wodonga City Council, Hovell Street, Wodonga.

PAUL JEROME
General Manager
Planning, Land and
Environment Regulation
Department of Sustainability
and Environment

ORDERS IN COUNCIL

Administrative Arrangements Act 1983

ADMINISTRATIVE ARRANGEMENTS ORDER (NO.187) 2003

The Governor in Council makes the following Order:

Dated 24 June 2003

Responsible Minister

J. THWAITES

Acting Premier

HELEN DOYE

Clerk of the Executive Council

1. Title

The Order is called the Administrative Arrangements Order (No. 187) 2003.

2. Authorising provision

This Order is made under section 3 of the **Administrative Arrangements Act 1983**.

3. Commencement

This Order takes effect on 5 December 2002.

4. Amendment of Administrative Arrangements Order (No. 183) 2002

In Administrative Arrangements Order (No. 183) 2002, after clause 6 insert-

"7. Keeping financial accounts and reports

- (1) The Secretary to the Department of Sustainability and Environment must ensure that financial accounts are kept and reports are provided for the purposes of the **Financial Management Act 1994** until 31 December 2002 in respect of any function under an Act specified in item 11, 13, 15, 17 or 19 in the Schedule that is transferred from the Department of Natural Resources and Environment to a New Body as if the function had not been transferred.
- (2) The Secretary to the Department of Human Services must ensure that financial accounts are kept and reports are provided for the purposes of the **Financial Management Act 1994** until 31 December 2002 in respect of any function under an Act specified in item 22, 25 or 28 in the Schedule that is transferred from the Department of Human Services to a New Body as if the function had not been transferred.
- (3) The Secretary to the Department of Justice must ensure that financial accounts are kept and reports are provided for the purposes of the **Financial Management Act 1994** until 31 December 2002 in respect of any function under the Act specified in item 31 in the Schedule that is transferred from the Department of Justice to a New Body as if the function had not been transferred.
- (4) The Secretary to the Department of Infrastructure must ensure that financial accounts are kept and reports are provided for the purposes of the **Financial Management Act 1994** until 31 December 2002 in respect of any function under an Act specified in item 36, 38 or 40 in the Schedule that is transferred from the Department of Infrastructure to a New Body as if the function had not been transferred.
- (5) The Secretary to the Department of Premier and Cabinet must ensure that financial accounts are kept and reports are provided for the purposes of the **Financial Management Act 1994** until 31 December 2002 in respect of any function under an Act specified in item 45, 48, 50 or 52 in the Schedule that is transferred from the Department of Premier and Cabinet to a New Body as if the function had not been transferred.

- (6) The Secretary to the Department of Treasury and Finance must ensure that financial accounts are kept and reports are provided for the purposes of the **Financial Management Act 1994** until 31 December 2002 in respect of any function under an Act specified in item 55 or 58 in the Schedule that is transferred from the Department of Treasury and Finance to a New Body as if the function had not been transferred.
- (7) The Secretary to the Department for Victorian Communities must ensure that financial accounts are kept and reports are provided for the purposes of the **Financial Management Act 1994** until 31 December 2002 in respect of any function under an Act specified in item 60, 62 or 64 in the Schedule that is transferred from the Department of Tourism, Sport and the Commonwealth Games to a New Body as if the function had not been transferred.
- (8) The Secretary to the Department of Innovation, Industry and Regional Development must ensure that financial accounts are kept and reports are provided for the purposes of the **Financial Management Act 1994** until 31 December 2002 in respect of any function under an Act specified in item 68 or 71 in the Schedule that is transferred from the Department of Innovation, Industry and Regional Development to a New Body as if the function had not been transferred.

8. Providing financial accounts and reports

The Secretary of a Department to which a function is transferred must, if so requested by the Secretary to a Department referred to in clause 7, provide the second-mentioned Secretary with any financial accounts and records or other information required to enable that Secretary to comply with clause 7.”

Cemeteries Act 1958

SCALE OF FEES

Order in Council

Under Section 17(1) of the **Cemeteries Act 1958**, and on the recommendation of the Minister for Health, the Governor in Council consents to the making of the Scales of Fees in respect of the following Public Cemetery Trusts:

Cathcart
Cobram
Maryborough
Nirranda
San Remo
Tongala
Wonthaggi
Yackandandah
Yea

Cemeteries Act 1958

SCALE OF FEES

By resolution of the Trust, the following fees will apply in the Cathcart Public Cemetery from the date of approval by the Governor in Council. All other fees are rescinded to the extent to which they conflict with this scale.

	\$
Land & interment	100.00
Placement of ashes in niche wall	100.00
Reservations for above	25.00
Exhumation charge	1,030.00
Permission to erect monument	25.00

JOHN BILLETT, trustee
JOHN McDONALD, trustee
RON BAXTER, trustee

Cemeteries Act 1958

SCALE OF FEES

By resolution of the Trust, the following fees will apply in the Cobram Public Cemetery from the date of approval by the Governor in Council. All other fees are rescinded to the extent to which they conflict with this scale.

	\$
Administration fee of \$100.00 per burial in the lawn, General and mausoleum (will not apply to a child under 5 years).	
Interment fee per child under 5 years	26.50
Interment fee in the general cemetery	100.00
Interment fee for ashes	100.00

JESSIE WOODS, trustee
MAX WOODS, trustee
RACHEL McKAY, trustee

Cemeteries Act 1958

SCALE OF FEES

By resolution of the Trust, the following fees will apply in the Maryborough Public Cemetery from the date of approval by the Governor in Council. All other fees are rescinded to the extent to which they conflict with this scale.

	\$
LAWN SECTION	
Land 2.44 m x 1.22 m	557.00
RE-OPEN GRAVES	
Lawn section	546.00
Monumental section	546.00
WALL NICHES	
In walls of memory	275.00

WAYNE KELLY, trustee
NOEL QUAIFFE, trustee
JOHN STEWART, trustee

Cemeteries Act 1958**SCALE OF FEES**

By resolution of the Trust, the following fees will apply in the Nirranda Public Cemetery from the date of approval by the Governor in Council. All other fees are rescinded to the extent to which they conflict with this scale.

	\$
Land 2.44 m x 1.22 m	150.00
Administrative fee per interment	50.00
Permission to erect headstone or monument	10% of cost with a minimum of \$50.00
Exhumation fee (when authorised)	500.00
	RAYMOND STANLEY LANE, trustee
	WALTER LYLE BURLEIGH, trustee
	ROBERT G. MOREY, trustee

Cemeteries Act 1958**SCALE OF FEES**

By resolution of the Trust, the following fees will apply in the San Remo Public Cemetery from the date of approval by the Governor in Council. All other fees are rescinded to the extent to which they conflict with this scale.

	NEW FEE
PRIVATE GRAVES	\$
Lawn grave 2.44 m x 1.22 m	660.00
Monumental section grave 2.44 m x 1.22 m	660.00
Each interment in monumental or lawn grave	330.00
Each interment in monumental or lawn grave – for child under 3 years	220.00
Bronze plaque and installation 382 mm x 280 mm	Contract cost plus 20%
Installation only of plaque by Trust	Contract cost plus 20%
NICHE WALL	
Niche wall – interment	385.00
Bronze plaque and installation	Contract price plus 20%
Interment and installation of plaque only	132.00
Niche wall – reservation	165.00
Niche wall – vase and installation	Contract price plus 20%
Transfer of ashes from another cemetery	132.00
MEMORIAL WALL	
Bronze plaque and installation 136 mm x 102 mm	Contract price plus 20%
Bronze Plaque and installation 382 mm x 280 mm	Contract price plus 20%
Installation of plaque only	132.00

MISCELLANEOUS CHARGES

Sinking grave for an oversize casket	110.00
Interment on a Saturday	66.00
Interment of ashes into grave	165.00
Permission to construct a brick, stone or concrete grave (monumental section only)	88.00
Permission to erect a headstone or monument (monumental section only)	88.00
Exhuming the remains of a body (when authorised)	990.00
Administration fee – records searching and on-site grave locations	22.00
All prices are GST inclusive	

JOHN GAINS, trustee
JOHN HULLEY, trustee
MIRANDA SAGE, trustee

Cemeteries Act 1958

SCALE OF FEES

By resolution of the Trust, the following fees will apply in the Tongala Public Cemetery from the date of approval by the Governor in Council. All other fees are rescinded to the extent to which they conflict with this scale.

	\$
Land 2.44 m x 1.22 m	400.00
Grave digging	240.00
Oversize grave	290.00

K. W. CHAPMAN, trustee
P. I. HAWKER, trustee
J. E. ANDREW, trustee

Cemeteries Act 1958

SCALE OF FEES

By resolution of the Trust, the following fees will apply in the Wonthaggi Public Cemetery from the date of approval by the Governor in Council. All other fees are rescinded to the extent to which they conflict with this scale.

	NEW FEE
	\$
PRIVATE GRAVES	
Lawn grave 2.44 m x 1.22 m	660.00
Monumental section grave 2.44 m x 1.22 m	660.00
Each interment in monumental or lawn grave	330.00
Each interment in monumental or lawn grave – for child under 3 years	220.00

Bronze plaque and installation 382 mm x 280 mm	Contract cost plus 20%
Installation only of plaque by trust	Contract cost plus 20%
NICHE WALL	
Niche wall – Interment	385.00
Bronze plaque and installation	Contract price plus 20%
Interment and installation of plaque only	132.00
Niche wall – reservation	165.00
Niche wall – vase and installation	Contract price plus 20%
Transfer of ashes from another cemetery	132.00
MEMORIAL WALL	
Bronze plaque and installation 136 mm x 102 mm	Contract price plus 20%
Bronze plaque and installation 382 mm x 280 mm	Contract price plus 20%
Installation of plaque only	132.00
MISCELLANEOUS CHARGES	
Sinking grave for an oversize casket	110.00
Interment on a Saturday	66.00
Interment of ashes into grave	165.00
Permission to construct a brick, stone or concrete grave (monumental section only)	88.00
Permission to erect a headstone or monument (monumental section only)	88.00
Exhuming the remains of a body (when authorised)	990.00
Administration fee – records searching and on site grave locations	22.00
All prices are GST inclusive	

JOHN GAINS, trustee
JOHN HULLEY, trustee
MIRANDA SAGE, trustee

Cemeteries Act 1958

SCALE OF FEES

By resolution of the Trust, the following fees will apply in the Yackandandah Public Cemetery from the date of approval by the Governor in Council. All other fees are rescinded to the extent to which they conflict with this scale.

PUBLIC GRAVES	\$
Land 2.44 m x 1.22 m	250.00
Administration fee per interment	75.00
PRIVATE GRAVES	
Land 2.44 m x 1.22 m	250.00
Own selection of land (extra)	130.00
Administration fee per interment	75.00
Interment of ashes in private grave	75.00

BUSH LAWN SECTION	
Land 2.44 m x 1.22 m	250.00
Administration fee per interment	75.00
MEMORIAL NICHE WALL	
Niche wall	250.00
Administration fee per interment	75.00
ROSE GARDEN	
Land 2.44 m x 1.22 m	250.00
Administration fee per interment	75.00
MISCELLANEOUS CHARGES	
Reservation fee (all areas except bush lawn)	75.00
Exhumation charge (when authorised)	1,030.00
Search fee	25.00
GRAVE DIGGING	Contract price
Permission to erect a headstone, monument or construct a brick grave, erect any stone, kerb, brick, tile work or concrete	50.00

PETER BRUCE McCLURG, trustee
 HAROLD LESLIE SCHOLZ, trustee
 K. WAITE, trustee

Cemeteries Act 1958

SCALE OF FEES

By resolution of the Trust, the following fees will apply in the Yea Public Cemetery from the date of approval by the Governor in Council. All other fees are rescinded to the extent to which they conflict with this scale.

The proposed fees are as follows:

DESCRIPTION OF FEE	NEW FEE
	\$
Purchase of land	520.00
Administration fee for prepaid funerals	100.00
Private selection of site (at time of burial)	115.00
Sinking of grave charge 2.13 m	GST inclusive contract price plus 10%
Single grave	GST inclusive contract price plus 10%
Re-open	GST inclusive contract price plus 10%
Any other services provided which are outside the scope of standard fees	GST inclusive contract price plus 10%
Child grave	GST inclusive contract price plus 10%
Oversize grave (width or length)	GST inclusive contract price plus 10%
Interment fee	220.00
Interment on Saturday, Sunday & Public Holidays	290.00

Re-opening of grave (no cover)	GST inclusive contract price plus 10%
Permission to erect monument	Minimum of \$95.00 GST inclusive contract price plus 10%
Reservation and Certificate of Right of Burial (includes purchase of land and private selection of site)	640.00
Placement of ashes in grave	115.00
Placement of plaques	60.00
Exhumation fee (when authorised)	1,030.00
COLUMBARIUM	
Purchase of niche	345.00
Pre-payment fee (per transaction)	100.00
Private selection of niche (at time of interment)	115.00
Reservation (includes purchase of niche and private selection of niche)	465.00
Interment fee	220.00
Purchase of plaque	GST inclusive contract price plus 10%
Placement of Pplaque	60.00

FRED PRYOR, trustee
MIKE DALMAN, trustee
G. R. MATTHEWS, trustee

Dated 17 June 2003
Responsible Minister:
HON BRONWYN PIKE MP
Minister for Health

BRIAN TUKE
Acting Clerk of the Executive Council

Cemeteries Act 1958

SCALE OF FEES

Order in Council

Under Section 17(1) of the **Cemeteries Act 1958**, and on the recommendation of the Minister for Health, the Governor in Council consents to the making of the Scales of Fees in respect of the following Public Cemetery Trusts:

Brighton
Hazelwood
Kyneton
Linton
Merbein
Queenscliff
Violet Town

Cemeteries Act 1958

SCALE OF FEES

By resolution of the Trust, the following fees will apply in the Brighton Public Cemetery from the date of approval by the Governor in Council. All other fees are rescinded to the extent to which they conflict with this scale.

	new fee includes GST
1 RIGHT TO BURIAL	\$
a) Lawn/monumental	3,300.00
b) Child under five	750.00
2 INTERMENT—PRIVATE	
a) Adult—lawn/monumental	1,060.00
b) Child—under five	410.00
c) Cremated remains	315.00
3 INTERMENT—PUBLIC	
a) Adult—lawn/monumental	335.00
b) Child—under five	95.00
4 MISCELLANEOUS	
a) Extra depth fee	145.00
b) Ledger removal—minimum	145.00
c) Oversize coffin/casket	160.00
d) Exhumation fee	1,745.00
e) Research fee	30.00
5 CREMATED REMAINS INTERMENT	
5.1 Individual Niche Wall	
a) Top two rows	375.00
b) Middle two rows	335.00
c) Remaining rows	305.00
5.2 Double Niche Wall	
a) Top two rows	750.00
b) Middle two rows	695.00
c) Remaining rows	655.00
5.3 Memorial Wall	
Cremated remains scattered memorial plaque on wall	125.00
5.4 Memorial Roses	
a) Roses—two interments	1,695.00
b) Additional interments	750.00
c) Garden—two interments	1,115.00
d) Additional interments	570.00
5.5 Memorial Gardens	
a) Rock—two interments	1,445.00
b) Additional interments	325.00
c) Tree—two interments	1,605.00
6 OTHER FEES	
a) Granite slab	725.00
b) Flower vase	45.00
c) Right to Burial certificate	40.00
d) Reservation for pre-need	65.00
e) Concrete-lined vaults	6,845.00
f) Placement of cremated remains in memorials	65.00

7 PLAQUE FEES

a) 559 mm x 305 mm	645.00
b) 380 mm x 280 mm	420.00
c) 275 mm x 205 mm	365.00
d) 152 mm x 114 mm	205.00
e) Recondition fee	215.00
f) Detachable plates	130.00
g) Plaque placement	30.00

JANET L. HANDS, trustee
R. S. FRANKLIN, trustee
KERRY MARTIN, trustee

Cemeteries Act 1958

SCALE OF FEES

By resolution of the Trust, the following fees will apply in the Hazelwood Public Cemetery from the date of approval by the Governor in Council. All other fees are rescinded to the extent to which they conflict with this scale.

LAND	\$
2.44 m x 1.22 m (8 ft x 4 ft)	495.00
1.22 m x 0.6 m (4 ft x 2 ft)	247.00
PLAQUES	
Plaques and fixing 380 mm x 215 mm (15 ft x 8 ¹ / ₂ ft)	330.00
Plaques and fixing 229 mm x 184 mm (9 ft x 7 ¹ / ₂ ft)	165.00
INTERMENT FEE	
Each interment	121.00
Each interment child section	60.50
RE-OPENING FEE	
For second interment	121.00
Flower containers	Cost plus 20%

All other prices remain as gazetted. All prices include GST.

L. BOND, trustee
M. J. WILLIS, trustee
TANJILEEN PERCIVALL, trustee

Cemeteries Act 1958

SCALE OF FEES

By resolution of the Trust, the following fees will apply in the Kyneton Public Cemetery from the date of approval by the Governor in Council. All other fees are rescinded to the extent to which they conflict with this scale.

MEMORIAL WALL	\$
Wall niche position (includes installation)	250.00
Supply and installation of bronze plaque	Contract price plus 50%

Flower container for memorial wall (includes installation)	35.00
Attendance fee when mourners wish to be present for interment of cremated remains into memorial wall, rose garden and graves	150.00
Exhumation fee (when authorised)	1,030.00

JOHN WILLMOTT, chairman
EDWARD WILLIAM JOLLY, trustee
CARL WILLIAM NIELSEN, trustee

Cemeteries Act 1958

SCALE OF FEES

By resolution of the Trust, the following fees will apply in the Linton Public Cemetery from the date of approval by the Governor in Council. All other fees are rescinded to the extent to which they conflict with this scale.

	\$
Administration fee—per interment	80.00
GRAVE SITE FEE	
Monumental section	120.00
Ashes memorial garden	300.00

PHILLIP E. LOMAS, trustee
ROD O'BEIRNE, trustee
KEVIN KNIGHT, trustee

Cemeteries Act 1958

SCALE OF FEES

By resolution of the Trust, the following fees will apply in the Merbein Public Cemetery from the date of approval by the Governor in Council. All other fees are rescinded to the extent to which they conflict with this scale.

LAWN SECTION AND MONUMENTAL SECTION	\$
Land 2.44 m x 1.22 m	250.00
First interment	290.00
Second interment	290.00
Interment of ashes in grave	100.00
Interment of ashes under trees/in grave	125.00
MISCELLANEOUS CHARGES	
Sinking oversize grave	70.00
Interment/administration fee	30.00
Interment on weekends/public holidays	50.00
Exhumation	1,030.00
Shelving of infant	175.00
Shelving of ashes	175.00
Monumental permit	75.00

ASHES IN LAWN SITES

Lawn site for interment of ashes only	110.00
Interment of ashes in ashes site	100.00

GEORGE WORTHINGTON, trustee
 BEN HOLLIS, trustee
 ELIZABETH MAFFEI, trustee

Cemeteries Act 1958

SCALE OF FEES

By resolution of the Trust, the following fees will apply in the Queenscliff Public Cemetery from the date of approval by the Governor in Council. All other fees are rescinded to the extent to which they conflict with this scale.

PRIVATE GRAVES	\$
Land 2.44 m x 1.22 m	550.00
Own selection of site (extra)	143.00
Compulsory pre-digging of sites (extra) (all sections except 2A & 3A)	297.00
Compulsory pre-digging of sites (extra) (sections 2A & 3A)	363.00
Land—reservation of non-specified graves	550.00
LAWN SECTION	
Land—first burial	616.00
Land—first burial, including plaque	880.00
Land—second burial including interment fee	297.00
Land—second burial including interment fee and plaque	561.00
Land—reservations	616.00
Land—reservations in lawn section (non specified graves—inc. plaque)	880.00
ROSE GARDEN SECTION	
First interment of ashes	286.00
First interment of ashes (including plaque and interment fee)	506.00
Second interment of ashes	209.00
Second interment of ashes (including plaque and interment fee)	429.00
PLAQUES	
For lawn section and rose garden—	
Fees quoted include cost of standard plaque	
Additional lines and motifs extra (at cost)	
Plaques must be to Trust standard where not supplied by Trust	
MONUMENT PERMIT FEES (INCLUDING RENOVATION WORK)	
Headstone up to \$1000 value	10% of cost
Headstone over \$1000 value	7% of cost—minimum \$154.00
Additional inscription	10% of cost—minimum \$44.00
Permission to construct a brick grave or any kerb, brick tilework or concrete must be obtained from the Trust	Fee \$88.00

MISCELLANEOUS CHARGES

Interment fee	154.00
Interment not in prescribed hours and Saturdays, Sundays or public holidays	176.00
Interment of ashes in a monument or lawn grave	132.00
Exhumation charge when authorised	1,100.00
Search Fees (per item)	minimum \$33.00

(Note: All fees are inclusive of Goods and Services Tax—GST)

BETTY E. SPRINGALL, trustee
 ARNOLD J. BENCH, trustee
 ALBERT G. BULLOCK, trustee

Cemeteries Act 1958

SCALE OF FEES

By resolution of the Trust, the following fees will apply in the Violet Town Public Cemetery from the date of approval by the Governor in Council. All other fees are rescinded to the extent to which they conflict with this scale.

	\$
LAWN SECTION	
Land 2.44 m x 1.22 m	420.00
Administrative fee per interment	420.00
Re-opening	315.00
OLD SECTION	
Re-opening	315.00
Interment	265.00
Grave digger	395.00
Sinking oversized grave	75.00
Exhumation	945.00
Ashes scattered or interred	90.00
Search fee	30.00
Land—right to be buried—single	1,120.00
—double	1,845.00

JOHN EDWARD DUNN, trustee
 KEITH LEWIS PLOZZA, trustee
 IAN ANGUS ERRY, trustee

Dated 24 June 2003

Responsible Minister:
 HON BRONWYN PIKE MP
 Minister for Health

HELEN DOYE
 Clerk of the Executive Council

Cemeteries Act 1958

SCALE OF FEES

Order in Council

Under Section 17(1) of the **Cemeteries Act 1958**, and on the recommendation of the Minister for Health, the Governor in Council consents to the making of the Scales of Fees in respect of the following public cemetery trusts:

Anderson's Creek

Dowling Forest

Hawkesdale

Leongatha

Marlo

Wangaratta

Warracknabeal

Yarragon

Cemeteries Act 1958

SCALE OF FEES

By resolution of the Trust, the following fees will apply to the Anderson's Creek Cemetery from the date of approval of the Governor in Council. All other fees are recinded to the extent to which they conflict with this scale.

	\$
Lawn grave 2.44 m x 1.22 m	1,396.00
Sinking new lawn grave to 1.5 m	1,048.00
Sinking new lawn grave to 2.1 m	1,280.00
Sinking new lawn grave to 2.7 m	1,512.00
Re-open lawn grave to 1.5 m	1,164.00
Re-open lawn grave to 2.1 m	1,396.00
Children's lawn grave maximum coffin length 1 m	1,047.00
Monumental grave 2.44 m x 1.22 m	2,127.00
Re-open monumental grave to 1.5 m	1,571.00
Re-open monumental grave to 2.1 m	1,802.00
Remove ledger and replace	291.00
Interment fee for vault	619.00
CREMATED REMAINS	
Memorial rose garden single plot	1,512.00
Memorial Rose Garden second interment or reserved prior to 1.10.1996	814.00
Garden/pathway single plot	1,280.00
Garden/pathway second interment or reserved prior to 1996	814.00
Children's ashes section	798.00
Niche wall single niche	1,047.00
Bence rock section	1,931.00

Transfer of cremated remains from ACCT – 50% of original cost refunded. Transaction is subject to an administration fee of	53.00
Relocation of cremated remains within the cemetery, 75% of original cost refunded. Transaction is subject to an administration fee of	53.00
The relocation of cremated remains is subject to purchase of a new plot at current rate.	
Placement of cremated remains in a private grave	206.00
Scattering of cremated remains in scattering area	232.00
Memorial rose garden in perpetuity	2,646.00
Garden/pathway in perpetuity	2,241.00
Niche wall in perpetuity	1,833.00
Bence Rock section in perpetuity	3,282.00
Children's section in perpetuity	1,396.00
EXTRAS	
Coffin or casket over 630 mm wide an extra	320.00
Flower container	34.00
Placement of plaque if supplied by family	232.00
Cancellation fee under 24 hours notice	349.00
Exhumation fee (plus re-opening fee)	1,746.00
Interment not in usual hours: before 9.00 & after 4.00pm weekdays an extra	516.00
Interment fee for a Saturday burial an extra	516.00

JOHN CHAPMAN, trustee
JOHN INGRAM, trustee
TERENCE SLOAN, trustee

Cemeteries Act 1958

SCALE OF FEES

By resolution of the Trust, the following fees will apply in the Dowling Forest Public Cemetery from the date of approval by the Governor in Council. All other fees are rescinded to the extent to which they conflict with this scale.

MONUMENTAL SECTION	\$
Land 2.44 m x 1.22 m	210.00
Reservation fee (Includes cost of land for first interment)	210.00
Administration fee per interment	82.00
Sinking grave 1.83 m deep	Contract price plus 10% surcharge
Re-opening grave (no cover)	220.00 (no change)
Re-opening grave (with cover) (Plus cost for monumental mason to remove and replace cover)	240.00 (no change)
Permission to erect headstone or monument or improvements to existing headstones or monuments	10% of the cost with a minimum 65.00
LAWN SECTION	
Land 2.44 m x 1.22 m (Includes first interment and administration fee)	350.00

Reservation fee includes cost of land for first interment and administration fee.	350.00
Second interment includes administration fee	230.00
Bronze plaque (381 mm x 279 mm) for above	At cost
Sinking grave 1.83 m deep	Contract price plus 10% surcharge
GENERAL	
Exhumation charge (including digging)	1,000.00
Search fee per request	22.00
Interment of ashes	90.00 (no change)
To any existing grave in the monumental or any existing grave in the lawn section plus the cost of a single bronze plaque in the lawn section (if required)	

JOHN PHILIPS, trustee
 MICHAEL IRVIN, trustee
 MICHAEL DAVEY, trustee

Cemeteries Act 1958

SCALE OF FEES

By resolution of the Trust, the following fees will apply in the Hawkesdale Public Cemetery from the date of approval by the Governor in Council. All other fees are rescinded to the extent to which they conflict with this scale.

	\$
Interment in grave without exclusive rights — stillborn	50.00
Interment in grave without exclusive rights — others	100.00
Peg or label	30.00
Private grave sites — old section 2.44 m x 1.22 m	100.00
Private grave sites — lawn section 2.44 m x 1.22 m	220.00
Grave digging — sinking & re-open sinking 1.83 m	Contract price + 10%
Each additional 0.3 m	Contract price + 10%
Re-open grave	Contract price + 10%
Oversize grave	Contract price + 10%
EXTRA CHARGES	
Interment on weekend	100.00
In private grave without notice	100.00
MISCELLANEOUS FEES	
Interment fee	75.00
Monument fee	50.00
Exhumation fee	950.00
Interment of ashes in existing private grave	75.00

PETER FRANCIS MURNANE, trustee
 ALLAN GORDON GOW, trustee
 DOUGLAS RICHMOND RALPH MALSEED, trustee

Cemeteries Act 1958**SCALE OF FEES**

By resolution of the Trust, the following fees will apply in the Leongatha Public Cemetery from the date of approval by the Governor in Council. All other fees are rescinded to the extent to which they conflict with this scale.

	\$
New lawn grave	1,600.00
Re-open lawn grave	1,400.00
New monumental grave	1,400.00
Re-open monumental	1,200.00
Children's grave	800.00
Niche for ashes	700.00
Tree or garden site for burial of ashes	800.00
The fees all include GST	

JESSIE ELIZABETH SPENCER, trustee
SHIRLEYANNE WRIGHT, trustee
ROBERT ARTHUR ATKIN, trustee

Cemeteries Act 1958**SCALE OF FEES**

By resolution of the Trust, the following fees will apply in the Marlo Public Cemetery from the date of approval by the Governor in Council. All other fees are rescinded to the extent to which they conflict with this scale.

	\$
LAWN OR MEMORIAL	
Adult	700.00
Child	455.00
Infant	200.00
Niche wall	300.00
Reserve	130.00
Admin/weekends, public holidays etc	195.00
RE-OPENING	
Large memorial	700.00
Medium	600.00
Interment of ashes in proposed memorial garden	325.00
Removal of ashes	130.00
Exhumation	1,300.00
Administration fee	50.00
Cancellation of order to sink if commenced	

Cost of backhoe hire plus 10%
ROBERT E. REDMAN, trustee
JUDY VAN DER VLUGT, trustee
ANITA M. PIKE, trustee

Cemeteries Act 1958**SCALE OF FEES**

By resolution of the trust, the following fees will apply in the Wangaratta Public Cemetery from the date of approval by the Governor in Council. All other fees are rescinded to the extent to which they conflict with this scale.

	\$
GRAVESITE	
General and lawn	715.00
Children under 12 months	132.00
Vault 1.5 blocks	1,100.00
INTERMENT FEES	
First, second, third interments	660.00
Children	385.00
Vault sealing	770.00
Extra charge Saturday or public holiday	550.00
LAWN PLAQUES (including installations)	
Single 380 mm x 280 mm	} Cost + 50% admin & handling fee
Dual	
Dual — detachable plate	
Memorial plaque	
INTERMENT OF ASHES	
Niche wall	550.00
Rose garden	550.00
Shrub/tree	770.00
Private gravesite	187.00
Disposal of ashes other than interment	110.00
Permission to erect headstone or monument	(min)
General cemetery 10% of cost	220.00
Lawn excluding flower containers	132.00
Second inscriptions	100.00
MISCELLANEOUS	
Search fee	44.00
Removal of cover (at owner's risk)	110.00
Exhumation fee	1,100.00
Use of canopy and chairs	30.00
Extra depth (to allow for third interment)	50.00
Certificate of Right of Burial	25.00
Cancellation of order	100.00
After scheduled burial hours per half-hour	50.00
Oversize grave	50.00

IRENE GRANT, trustee
 KEIRAN A. KLEMM, trustee
 ANTHONY GRIFFITHS, trustee
 GEOFFREY N. DINNING, trustee

Cemeteries Act 1958

SCALE OF FEES

By resolution of the Trust, the following fees will apply in the Warracknabeal Public Cemetery from the date of approval by the Governor in Council. All other fees are rescinded to the extent to which they conflict with this scale.

LAWN SECTION	\$
Land	602.00
Sinking grave 1.83 m	319.00
Sinking grave 2.13 m	361.00
Re-open	319.00
MONUMENT SECTION	
Land	301.00
Sinking grave 1.83 m	319.00
Sinking grave 2.13 m	361.00
Re-open	319.00
MISCELLANEOUS CHARGES	
Sinking child's grave	187.00
Administration fee per interment	90.00
Weekend interment (extra)	132.00
Weekend, public holiday digging (extra)	127.00
Removal of slab	80.00
Digging inside curb	42.00
Oversize grave	91.00
Exhumation of body (when authorised)	860.00
Interment of ashes in niche wall	246.00
Interment of ashes in general section	132.00
Markets certificate	24.00

ROBERT K. STREETER, trustee

GARY D. FARRAH, trustee

LINDSAY TAYLOR V. P. trustee

Cemeteries Act 1958

SCALE OF FEES

By resolution of the Trust, the following fees will apply in the Yarragon Public Cemetery from the date of approval by the Governor in Council. All other fees are rescinded to the extent to which they conflict with this scale.

	\$
Circle for ashes, lawn	500.00
Second interment	300.00
Ashes wall	350.00
Land for graves	610.00

Grave excavation	300.00
Removal of slab	300.00
Baby grave	150.00
Interment	200.00
Public grave	150.00
Reservation	200.00
Interment, weekends or public holidays	300.00
Exhumation	860.00
All plaques at wholesale price plus 50%	

STUART JOHN NICHOLAS, trustee
GRAEME GRANT ROBERTS, trustee
HARRY LANGRES, trustee

Dated 24 June 2003
Responsible Minister:
HON BRONWYN PIKE MP
Minister for Health

HELEN DOYE
Clerk of the Executive Council

Cemeteries Act 1958

SCALE OF FEES

Order in Council

Under Section 17(1) of the **Cemeteries Act 1958**, and on the recommendation of the Minister for Health, the Governor in Council consents to the making of the Scales of Fees in respect of the following Public Cemetery Trusts:

Avoca
Bairnsdale
Devenish
Drouin
Greta
Hamilton
Harrow

Cemeteries Act 1958

SCALE OF FEES

By resolution of the Trust, the following fees will apply in the Avoca Cemetery from the date of approval by the Governor in Council. All other fees are rescinded to the extent to which they conflict with this scale.

LAWN SECTION	\$
Land 2.44 m x 1.22 m	500.00
Sinking	250.00
Interment fee	50.00

Total	800.00
RE-OPEN LAWN SECTION	
Sinking	250.00
Interment fee	50.00
Total	300.00
MEMORIAL WALL	
Niche	150.00
Installation of plaque 152 mm x 152 mm Plus cost of plaque as ordered	25.00
Total	175.00
GENERAL SECTION	
New ground	200.00
Sinking	250.00
Interment fee	50.00
Total	500.00
RE-OPEN GENERAL SECTION	
Removal of slab	50.00
Sinking	250.00
Interment fee	50.00
Total	350.00
Exhumation fee when authorised	800.00

JOHN T. CHAPMAN, trustee
 KEITH ASTBURY, trustee
 JOHN A. CHAPMAN, trustee

Cemeteries Act 1958

SCALE OF FEES

By resolution of the Trust, the following fees will apply in the Bairnsdale Public Cemetery from the date of approval by the Governor in Council. All other fees are rescinded to the extent to which they conflict with this scale.

CHILDREN'S LAWN	\$
Length 1.4 m—site, digging and maintenance	554.00
MEMORIAL GARDEN	
Site and interment of ashes	333.00
Opening and re-sealing of concrete-lined grave	603.00
Land	744.00
Interment	373.00
Re-open	588.00
Western niche wall	310.00
Eastern niche wall	245.00
Grave dug extra depth, or less than 24 hours notice or public holiday	260.00

Supply and installation concrete-lined grave	4,342.00
Opening and re-sealing concrete-lined grave	651.00
Interment of ashes in private grave	142.00
Exhumation fee	1,240.00

TIM GIBSON, trustee

DARREN GOODMAN, trustee

MARGARET HANNINGTON, trustee

Cemeteries Act 1958

SCALE OF FEES

By resolution of the Trust, the following fees will apply in the Devenish Public Cemetery from the date of approval by the Governor in Council. All other fees are rescinded to the extent to which they conflict with this scale.

GENERAL MONUMENTAL SECTION	\$
Land	145.00
Interment fee	110.00
Permission to erect headstone/monument	55.00
NICHE WALL	
Interment fee	110.00
Site	80.00
NEW SECTION/SCORIA	
Gravesite	275.00
First interment fee	120.00
Second interment fee	275.00
Grave digging	360.00
Headstone (as prescribed by Trust)	780.00

BRIAN CHARLES HARKER, trustee

WILLIAM JOHN SHARP, trustee

KIRSTY LOUISE HARKER, trustee

Cemeteries Act 1958

SCALE OF FEES

By resolution of the Trust, the following fees will apply in the Drouin Public Cemetery from the date of approval by the Governor in Council. All other fees are rescinded to the extent to which they conflict with this scale.

LAWN SECTION AND MONUMENTAL SECTION	\$
Land 2.44 x 1.22 m, new grave or reservation	570.00
Sinking grave to 185 cm	345.00
Sinking grave for child	140.00
Interment fee	255.00

To re-open grave (includes interment fee)	600.00
Standard plaque can be arranged through the Trust	GST inclusive price plus 10%
To erect headstones	GST inclusive price plus 10%
To remove and replace ledger	330.00
Weekend or public holiday interment: extra	250.00
Sinking grave for each extra 0.3 m	80.00
MONUMENTAL BEAM SECTION	
Land 2.44 x 1.22 m, new grave or reservation	640.00
Sinking grave to 185 cm	345.00
Sinking grave for child	140.00
Interment fee	245.00
To re-open grave (includes interment fee)	600.00
To erect headstones	GST inclusive price plus 10%
Weekend or public holiday interment: extra	250.00
Sinking grave for each extra 0.3 m	80.00

DESMOND C. EYLES, trustee
IAN THOMAS GAFFNEY, trustee
DONALD R. BLACKLEY, trustee

Cemeteries Act 1958

SCALE OF FEES

By resolution of the Trust, the following fees will apply in the Greta Public Cemetery from the date of approval by the Governor in Council. All other fees are rescinded to the extent to which they conflict with this scale.

	\$
Interment in grave without exclusive right—stillborn child	45.00
Interment in grave without exclusive right—others	90.00
Private grave	90.00
Sinking (each additional 0.3 m)	45.00
Cancellation of order to sink (if commenced)	30.00
Re-opening grave (no cover)	60.00
Re-opening grave (with cover)	70.00
Interment outside prescribed hours	40.00
Interment of ashes	40.00
Search fee per request	16.00

KENNETH ELLIS, trustee
NOELEEN LLOYD-SMITH, trustee
DAWN SALAD, trustee

Cemeteries Act 1958

SCALE OF FEES

By resolution of the Trust, the following fees will apply in the Hamilton Public Cemetery from the date of approval by the Governor in Council. All other fees are rescinded to the extent to which they conflict with this scale.

INTERMENT IN GENERAL CEMETERY	\$
Land	415.00
Interment	250.00
Digging—2.13 M (7ft)	553.00
Extra charge—interment Saturday of gazetted holiday	314.00
Additional fee—for second interment in a grave with slab	62.00
Installation of commemorative plaque on ancestral grave	200.00
Interment of ashes in private grave with a slab	250.00
Exhumation	1,700.00
INTERMENT IN LAWN CEMETERY	
Land	723.00
Interment	250.00
Digging—2.13 M (7ft)	553.00
Oversize coffins—additional	50.00
Caskets—additional	100.00
Interment in babies section	200.00
Interment in youth section	460.00
Interment of ashes in private grave	250.00
Interment of ashes in niche wall	92.00
Interment of ashes in rose garden	150.00
Extra charge—interment Saturday or gazetted holiday	314.00
PLAQUES	
Single plaque—up to six lines (381 mm x 216 mm)	316.25
Extra inscription—per line	23.00
Motif—type A, B or C attached to plaque	34.50
Motif—type D attached to plaque	69.00
Double plaque—two lines on plaque (381 mm x 216 mm) —five lines on detachable plaque	442.75
Detachable plate for second interment	143.75
Milled ceramic tile with initial plaque order (5 cm x 7 cm)	327.75
Milled ceramic tile after plaque on grave (5 cm x 7 cm)	425.50
Tree plaque for rose garden (229 mm x 184 mm)	161.00
Plaque for ashes wall (137 mm x 102 mm)	143.75
Niche vase with screw attachment (Code M121)	113.85
Plaque cleaning	85.00

KEVIN BERTRAM JOHN THOMAS, trustee
KEVIN DAVID BAILEY, trustee
WILLIAM RANDOLPH MALLINSON, trustee

Cemeteries Act 1958**SCALE OF FEES**

By resolution of the Trust, the following fees will apply in the Harrow Public Cemetery from the date of approval by the Governor in Council. All other fees are rescinded to the extent to which they conflict with this scale.

MONUMENTAL SECTION	\$
Plot	90.00
Digging single depth	305.00
Digging double depth	325.00
Interment	100.00
Re-opening grave (no cover)	310.00
Re-opening grave (with cover)	350.00
Exhumation	1,030.00
Cancellation of order to sink	80.00
Sinking oversize grave extra	50.00
Interment of ashes	60.00
LAWN SECTION	
Plot	90.00
Digging single depth	305.00
Digging double depth	325.00
Interment	100.00
Plaque	220.00
Exhumation	1,030.00
Cancellation of order to sink	80.00
Sinking oversize grave extra	50.00
Interment of ashes	60.00

JOHN SANDIFORD STAUSE, trustee
 WILLIAM R. AMON, trustee
 THOMAS GORDON PENNY, trustee

Dated 24 June 2003
 Responsible Minister:
 HON BRONWYN PIKE MP
 Minister for Health

HELEN DOYE
 Clerk of the Executive Council

Cemeteries Act 1958

SCALE OF FEES

Order in Council

Under Section 17(1) of the **Cemeteries Act 1958**, and on the recommendation of the Minister for Health, the Governor-in-Council consents to the making of the Scales of Fees in respect of the following public cemetery trusts:

Carngham
Colac
Creswick
Eltham
Frankston
Lilydale
Meeniyan
Nhill

Cemeteries Act 1958

SCALE OF FEES

By resolution of the Trust, the following fees will apply in the Carngham Cemetery from the date of approval by the Governor in Council. All other fees are rescinded to the extent to which they conflict with this scale.

NEW GRAVE	\$
Land	150.00
Right of Burial	10.00
Marker	16.50
Interment fee	80.00
Grave digging	Contract price
GRAVE OPENING	
Grave digging	Contract price
Removal of cover if needed — Done by monumental mason at their cost	
Interment fee	80.00
LAWN CEMETERY	
Land	650.00
Interment fee	80.00
Headstone	350.00
Grave digging	Contract price
WALL NICHE	
Niche	200.00
Interment fee	80.00
Installation	50.00
Plaque	Approximately 160.00

LIN GERARD BRUTY, trustee
COLIN MORRIS WILLIAMS, trustee
DAVID MORCOMBE, trustee

Cemeteries Act 1958

SCALE OF FEES

By resolution of the Trust, the following fees will apply in the Colac Public Cemetery from the date of approval by the Governor in Council. All other fees are rescinded to the extent to which they conflict with this scale. (GST inclusive).

MONUMENTAL AREA	\$
Land 2.44 m x 1.22 m	411.00
Re-opening grave	581.00
Ashes in grave	182.00
Pre-sunk vault*	4,400.00
LAWN AREA	
Land 2.44 m x 1.22 m	750.00
Re-opening grave	508.00
Small grave – one child	97.00
Interment of ashes in grave	182.00
BOTH AREAS	
Sinking grave 1.69 m deep	508.00
Right of Burial Certificate	48.00
Interment administration fee	145.00
MEMORIAL WALL	
Wall niche	302.00
Garden niche (New area)	423.00
Placing ashes and affixing plaque	170.00
OTHER	
Exhuming remains of body	605.00
Shelving a coffin	70.00
Interment on Saturday, Sunday or public holidays (extra)	121.00
Permission to erect a headstone, slab, etc	30.00
Monumental masons registration fee	60.00
Search fee	17.00

* New area presently being established

PETER DEVINE, trustee
 STEWART OBORNE, trustee
 MAX MARRINER, trustee

Cemeteries Act 1958

SCALE OF FEES

By resolution of the Trust, the following fees will apply in the Creswick Public Cemetery from the date of approval by the Governor in Council. All other fees are rescinded to the extent to which they conflict with this scale.

LAWN AREA	\$
Land	595.00
Headstone (no lettering)	Contract price plus 10%
Grave digging	Contract price plus 10%
Administration	110.00
Re-opening grave	Contract price plus 10%
DENOMINATIONAL AREA	
Land 2.44 m x 1.22 m	396.00
Grave digging or re-opening private grave	Contract price plus 10%
Administration	110.00
CHILDREN'S LAWN SINGLE INTERMENT	
Land 0.93 x 0.61 m child to 3 months	220.00
land 2.44 x 1.22 m child to 4 months to 12 years	320.00
Grave digging	Contract price plus 10%
Plaque	Contract price plus 10%
MEMORIAL WALL	
Wall niche	100.00
Plaque	Contract price plus 10%
Fitting ashes & plaques	72.00
MISCELLANEOUS CHARGES	
Grave digging — Weekend, public holiday digging (extra)	110.00
Grave digging or re-opening oversized grave (extra)	110.00
Burial of ashes in grave	110.00
MONUMENTAL FEES	
Headstone for lawn grave includes first and additional inscription	33.00
Regilding original inscription	Contract price plus 10%
Research fee	20.00
Exhumation of body (when authorised)	1,030.00
All other monumental work including improvements	Contract price plus 10%
All fees GST inclusive	

KIERAN JOSEPH MOORE, trustee
STEPHEN ATKINSON, trustee
WENDY JOAN OHLSEN, trustee

Cemeteries Act 1958

SCALE OF FEES

By resolution of the Trust, the following fees will apply in the Eltham Public Cemetery from the date of approval by the Governor in Council. Previous fees for these services are rescinded to the extent to which they conflict with this scale.

LAWN & MONUMENTAL SECTIONS:	\$
Land 2.4 m x 1.3 m — at need	1,800.00
Land 2.4 m x 1.3 m — preneed	2,500.00

SINKING & INTERMENT CHARGES

Interment fee to 2.00 m for standard coffin*	1,150.00
Interment fee to 2.50 m for standard coffin*	1,250.00
Re-open grave for second or further interment — standard coffin*	1,150.00
Sinking or re-opening for oversized coffin or casket — additional	325.00

*Standard coffin measurements do not exceed 2050 mm x 630 mm

ADDITIONAL & MISCELLANEOUS CHARGES

Additional inscription of headstone/authorization of inscription	60.00
------------------------------------------------------------------	-------

All fees are GST inclusive

TERRY WOOLLEY, trustee
GEOFF WATT, trustee
FRED HARRINGTON, trustee

Cemeteries Act 1958**SCALE OF FEES**

By resolution of the Trust, the following fees will apply in the Frankston Memorial Park Public Cemetery from the date of approval by the Governor in Council. All other fees are rescinded to the extent to which they conflict with this scale.

	Recommended
SINKING AND INTERMENT CHARGES	\$
Standard grave size to 2.13 m (first/second interment)	911.00
2.43 m (for 3 interments)	982.00
Oversize grave (casket) (Monumental area only)	982.00
RE-OPENING CHARGES	
Re-opening and interment (no cover)	911.00
Re-opening and interment (with cover)	982.00
Re-opening and interment (Lawn)	911.00
LAWN SECTION	
Bronze plaque first/second interment	303.00
Second detachable plate (4 – 5 lines)	88.00
(Single plaque 6 lines) (D/C base plate 2 lines) (1* D/C plate 4 – 5 lines)	
Pre-need monumental graves (when available)	1,807.00
MEMORIAL NICHE WALLS NOS. 1 AND 2	
Niche in wall 40 year tenure	297.00
Interment fee	105.00
Bronze plaque (NW 1 — 3 lines) (NW 2 — 5 lines)	140.00
Niche wall vase	34.00
EXTRA CHARGES	
Interment not in usual hours	351.00
Interment on Saturdays, Sundays, Public holidays	584.00
Interment in grave without due notice	—

MEMORIAL TREES (25 YEAR TENURE)	
Main Drive (maximum 4 persons each, sold individually)	
Reservation and interment	380.00
Reservation only	253.00
Bronze plaque (8 lines)	140.00
Vase	34.00
ARBOUR WALK (25 YEAR TENURE)	
Large & small planter and pillars	
Ashes recoverable	690.00
Ashes non recoverable	572.00
Bronze plaque (5 lines)	140.00
Vase	34.00
CARPET ROSE GARDEN (25 YEAR TENURE)	
Reservation and interment	526.00
Bronze plaque (8 lines)	140.00
Reservation only	351.00
MEMORIAL TREE — GOVERNMENT ROAD	
Reservation and interment	655.00
Bronze plaque (8 lines)	140.00
Vase	34.00
Reservation only	479.00
MEMORIAL ROCK	
Reservation and interment	760.00
Bronze plaque (8 lines)	140.00
Second interment	380.00
STANDARD ROSE	
Reservation and interment	625.00
Plaque	140.00
Plaque with vase	174.00
Reservation only	469.00
MISCELLANEOUS CHARGES	
Duplicate Certificate Right of Burial	46.00
Placing of plaques (Monumental)	140.00
Interment of ashes in private grave	193.00
With family in attendance (additional)	76.00
Exhuming of remains of a body (when authorised)	1,520.00
Late fee (per half hour or part thereof in excess of first 15 minutes)	41.00
Additional lines are \$14.00 each for single and dual conversion plaques	
Additional lines for all other plaques are \$11.00 each	
All prices listed are inclusive of GST	

BARRY PRIESTLEY, trustee
 CATHY WILSON, trustee
 VICKI McCLELLAND, trustee

Cemeteries Act 1958**SCALE OF FEES**

By resolution of the Trust, the following fees will apply in the Lilydale Lawn, Lilydale Memorial Park, Yarra Glen & Healesville Public Cemeteries from the date of approval by the Governor in Council. All other fees are rescinded to the extent to which they conflict with this scale.

MONUMENTAL GRAVES

MONUMENTAL GRAVE	\$
Includes site and sinking to 2.1 m	
Lilydale Lawn Cemetery	2,046.00
Healesville Cemetery	1,710.00
Yarra Glen Cemetery	1,710.00
MONUMENTAL GRAVE	
Sinking pre-purchased grave to 2.1 m	1,108.00
MONUMENTAL GRAVE	
Re-open grave	1,108.00
PRE-PURCHASE MONUMENTAL GRAVE	
Healesville Cemetery	602.00
Yarra Glen Cemetery	602.00

LAWN GRAVES

LAWN GRAVE	
Includes site and sinking to 2.1 m	
Lilydale Memorial Park	1,925.00
Healesville Cemetery	1,590.00
Yarra Glen Cemetery	1,590.00
LAWN GRAVE	
Sinking pre-purchased grave to 2.1 m	988.00
LAWN GRAVES	
Re-open all lawn graves	940.00
PRE-PURCHASE LAWN GRAVE	
Lilydale Memorial park	1,213.00
Healesville	876.00
Yarra Glen	876.00
GARDEN LAWN GRAVE (Headstone not included)	
Includes site and sinking to 2.1 m	3,600.00
Pre-purchase Garden Lawn Grave	2,935.00
PAVILION LAWN GRAVE	
Includes site and sinking to 2.1 m	3,000.00
Pre-purchase Pavilion Lawn Grave	2,287.00
CONCRETE LINED GRAVE	
CONCRETE LINED GRAVE (VAULT)	
Includes site concrete liner and first interment	
Lilydale Memorial Park	8,063.00
Healesville Cemetery	7,461.00

CONCRETE LINE GRAVE	
Re-open concrete lined grave	1,204.00
PRE-PURCHASED CONCRETE LINED GRAVE	
Lilydale Memorial Park	6,833.00
Healesville Cemetery	6,531.00
CHILDREN'S LAWN GRAVE	
CHILDREN'S LAWN GRAVE	
Includes site, sinking and vase receptacle, No plaque included (maximum coffin length 1.10 m)	
Lilydale Memorial Park	736.00
Healesville Cemetery	736.00
Remove ledger, replace and reseal	319.00
Extra sinking depth to 2.7 m	217.00
Lilydale Lawn Cemetery	
Lilydale Memorial Park	
Yarra Glen Cemetery	
Healesville Cemetery	
INTERMENT OF CREMATED REMAINS	
Includes interment of the cremated remains (No plaque)	
WALL NICHE	
Includes interment of the cremated remains (No plaque)	675.00
GRANITE MEMORIAL	
Includes interment of the cremated remains (No plaque)	2,642.00
GRANITE EDGE MEMORIAL	
Includes interment of the cremated remains (No plaque) (Section EE)	2,010.00
CHILDREN'S CREMATED REMAINS MEMORIAL	
Includes interment of the cremated remains (No plaque)	265.00
CHILDREN'S REMEMBRANCE	
VINE	
(no interment)	
Includes memorial sales and leaf shape plaque	231.00
REMEMBRANCE VINE	
(no interment)	
Includes memorial sales and leaf shape plaque	316.00
Interment of cremated remains in lawn/monumental grave	180.00
Second interment of cremated remains in Cremated Remains Memorial	121.00
ROSE GARDEN MEMORIAL	
Includes interment of the cremated remains (No plaque)	987.00
COORING YERING MEMORIAL	
Includes interment of the cremated remains (No plaque)	1,760.00
NATIVE SHRUB MEMORIAL	
Includes interment of the cremated remains (No plaque)	572.00
MEMORIAL LAWN	
Includes interment of the cremated remains (No plaque)	465.00

EXTENDED CHAPEL TIME	
Additional 1 hour in chapel	153.00
CATERING CHARGES	
Menu 1 — Up to 60 guests Tea, coffee, cordial & assorted biscuits	180.00
Menu 2 — Minimum 40 guests Tea, coffee, cordial, assorted biscuits & platter of mixed cakes (1 piece per head)	180.00
Additional \$4.50 per head	
Menu 3 — Minimum 40 guests Tea, coffee, cordial, assorted biscuits, sandwiches (3 pieces per head), Platter of mixed cakes (1 piece per head)	214.00
Additional \$5.50 per head	
Menu 4 — Minimum 40 guests Tea, coffee, cordial, assorted biscuits, hot finger food (3 pieces per head), Platter of mixed cakes (1 piece per head)	300.00
Additional \$7.50 per head	
Menu 5 — Minimum 40 guests Tea, coffee, cordial, hot finger food (3 pieces per head), Sandwiches (3 pieces per head), Platter of mixed cakes (1 piece per head)	380.00
Additional \$9.50 per head	
ADDITIONAL OPTIONS	
Mini muffins (3 pieces per head)	2.00
Cheese or Gourmet Dip Platter	55.00
Fresh fruit platter	66.00
Soft drinks (per 2 litre bottle)	3.50
Catering items by special request	Cost + 100%
ADDITIONAL INFORMATION	
Items by special request not listed in account list	Contractor fee + 80%
	Mr ROD BLACKBURN, trustee
	Mr JIM SAWYER, trustee
	Mrs EILEEN TRENKNER, trustee

Cemeteries Act 1958

SCALE OF FEES

By resolution of the Trust, the following fees will apply in the Meeniyan Public Cemetery from the date of approval by the Governor in Council. All other fees are rescinded to the extent to which they conflict with this scale.

	\$
Exhumation charge (when authorised)	1,030.00
	NEVILLE MEIKLE, trustee
	PHILIP R. BENSON, trustee
	WAYNE G. COOK, trustee

Cemeteries Act 1958

SCALE OF FEES

By resolution of the Trust, the following fees will apply in the Nhill Public Cemetery from the date of approval by the Governor in Council. All other fees are rescinded to the extent to which they conflict with this scale.

	\$
Exhumation charge (when authorised)	1,030.00
LAWN CEMETERY OR SECTION	
Lawn grave (land) 2.44 m x 1.22 m	700.00
Bronze plaque, base, headstone	550.00
Small niche on bronze plaque	110.00

WILFRED A. REICHEL, (chair)

FREDERICK JOHN SMITH, trustee

MICHAEL LAWRENCE LYNCH, trustee

Dated 24 June 2003
Responsible Minister:
HON BRONWYN PIKE MP
Minister for Health

HELEN DOYE
Clerk of the Executive Council

Control of Weapons Act 1990**Act No. 24/1990**

ORDER IN COUNCIL

The Governor-in-Council, pursuant to section 8B of the **Control of Weapons Act 1990**, grants an exemption to Authorised Fisheries Officers from the operation of section 5(1) of the **Control of Weapons Act 1990** in relation to bringing into Victoria, causing to be brought into or sent into Victoria, purchasing, possessing, using or carrying oleoresin capsicum spray in the performance of their official duties.

For the purposes of this Order, "Authorised Fisheries Officers" means those persons appointed as authorised officers under the **Conservation, Forests and Lands Act 1987** for the purposes of the **Fisheries Act 1995** and whose official duties involve the enforcement of the provisions of the **Fisheries Act 1995**.

Under section 8B of the **Control of Weapons Act 1990**, this exemption applies only to Authorised Fisheries Officers who:

- (a) have successfully completed the training requirements set out in the training manual issued by the Secretary of the Department of Primary Industries and endorsed by the Minister for Police and Emergency Services, in relation to oleoresin capsicum spray; and
- (b) comply at all times with the instructions set out in the policy and operating procedures issued by the Secretary of the Department of Primary Industries and endorsed by the Minister for Police and Emergency Services in relation to the issue, carriage, use and storage of oleoresin capsicum spray.

This Order comes into operation on 29 June 2003.

Dated 24 June 2003
ANDRÉ HAERMMEYER
Minister for Police
and Emergency Services

HELEN DOYE
Clerk of the Executive Council

Crown Land (Reserves) Act 1978NOTICE OF INTENTION TO REVOKE
TEMPORARY RESERVATIONS

The Governor in Council under section 10 of the **Crown Land (Reserves) Act 1978** gives notice of intention to revoke the following temporary reservations:

BROADFORD — The temporary reservation by Order in Council of 14 April, 1885 of an area of 4.568 hectares of land in the Parish of Broadford (formerly being Crown Allotment 11, Section 5) as a site for a Quarry. — (06/07537).

COONOOER EAST — The temporary reservation by Order in Council of 16 March, 1880 of an area of 8.627 hectares, of land in Section A, Parish of Coonooer East as a site for a Quarry. — (2002327).

LETHBRIDGE — The temporary reservation by Order in Council of 20 January, 1915 of an area of 658 square metres of land in two separate portions in Sections 17 and 18, Township of Lethbridge (formerly Town of Lethbridge), Parish of Wabdallah as a site for a Pipe Track. — (Rs 492).

VIOLET TOWN — The temporary reservation by Order in Council of 22 April, 1969 of an area of 3794 square metres more or less, of land in Section 17, Township of Violet Town, Parish of Shadforth as a site for Public purposes (Police purposes). — (Rs 9114).

This Order is effective from the date on which it is published in the Government Gazette.

Dated 24 June 2003

Responsible Minister
MARY DELAHUNTY
Minister for Planning

HELEN DOYE
Clerk of the Executive Council

Crown Land (Reserves) Act 1978REVOCATION OF TEMPORARY
RESERVATIONS

The Governor in Council under section 10 of the **Crown Land (Reserves) Act 1978** revokes the following temporary reservations:

KOO-WEE-RUP EAST — The temporary reservation by Order in Council of 30 April, 1957 of an area of 7841 square metres, more or

less, of land in the Parish of Koo-wee-rup East as a site for a Municipal Depot. — (Rs 7564).

SAN REMO — The temporary reservation by Order in Council of 22 April, 1969 of an area of 3.845 hectares of land in the Township of San Remo, Parish of Woolamai as a site for Public Recreation, so far only as the portion containing 2932 square metres being Crown Allotment 2002, Township of San Remo as indicated by hatching on plan published in the Government Gazette on 22 May, 2003 page – 1222. — (Rs 9152).

SCORESBY — The temporary reservation by Order in Council of 4 December, 2001 of an area of 747.3 hectares, more or less, of land in the Parishes of Nunawading, Scoresby, Mulgrave and Narree Worran as a site for conservation, recreation, leisure and tourism purposes, so far only as the portions containing a total of 9127 square metres shown as Crown Allotments 2017, 2018, 2019 and 2020, Parish of Scoresby on Plan No. LEGL./03–002 lodged in the Central Plan Office. — (LA/24/0011).

This Order is effective from the date on which it is published in the Government Gazette.

Dated 24 June 2003

Responsible Minister
MARY DELAHUNTY
Minister for Planning

HELEN DOYE
Clerk of the Executive Council

Crown Land (Reserves) Act 1978TEMPORARY RESERVATION OF
CROWN LAND

The Governor in Council under Section 4(1) of the **Crown Land (Reserves) Act 1978** temporarily reserves the following Crown land which in his opinion is required for the purpose mentioned:–

MUNICIPAL DISTRICT OF THE
BANYULE CITY COUNCIL

KEELBUNDORA — Public Purposes and for the Study of Art, 5533 square metres being Crown Allotment 2004, Parish of Keelbundora shown as Lot 1 on Plan of Subdivision No. 302641C lodged in the Office of Titles. — (LA/20/0164).

This Order is effective from the date on which it is published in the Government Gazette.

Dated 24 June 2003

Responsible Minister
MARY DELAHUNTY
Minister for Planning

HELEN DOYE
Clerk of the Executive Council

Crown Land (Reserves) Act 1978
TEMPORARY RESERVATION OF
CROWN LANDS

The Governor in Council under section 4(1) of the **Crown Land (Reserves) Act 1978** temporarily reserves the following Crown lands which in his opinion are required for the purposes mentioned:-

MUNICIPAL DISTRICT OF THE
GOLDEN PLAINS SHIRE COUNCIL

CLARKESDALE — Public Recreation, 2.769 hectares being Crown Allotment 17C, Section B, Parish of Clarkesdale as shown on Original Plan No. 120920 lodged in the Central Plan Office. — (05P103972).

MUNICIPAL DISTRICT OF THE
BANULE CITY COUNCIL

HEIDELBERG — Hospital purposes, 9200 square metres, more or less, being Crown Allotment 2001, Township of Heidelberg, Parish of Keelbundora as indicated by hatching on plan hereunder. — (GP1191) — (Rs 1297).

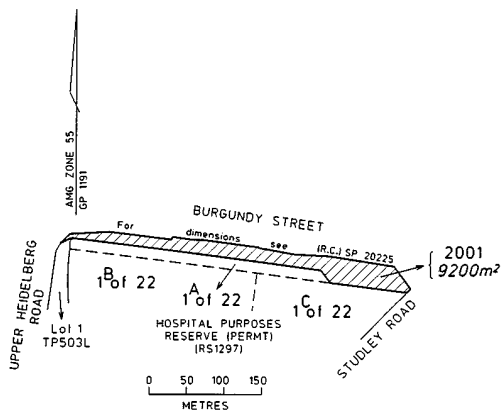

MUNICIPAL DISTRICT OF THE
WEST WIMMERA SHIRE COUNCIL

KANIVA — State School purposes, 6768 square metres, being Crown Allotment 2005, Township of Kaniva, Parish of Kaniva as shown on Original Plan No. 121966 lodged in the Central Plan Office. — (Rs 4906).

MUNICIPAL DISTRICT OF THE
GREATER GEELONG CITY COUNCIL

LITTLE RIVER — Public purposes, 3825 square metres being Crown Allotment 2003, Township of Little River, Parish of Murteaim shown as Reserve No. 2 on Plan of Subdivision No. 448595Q lodged in the Office of Titles. — (07/L1-4838).

MUNICIPAL DISTRICT OF THE
LATROBE CITY COUNCIL

MARYVALE — Public purposes (Police Station and Courthouse), 1.3 hectares, being Crown Allotment 2010, Parish of Maryvale as indicated by hatching on plan hereunder. — (GP1098) — (P371289).

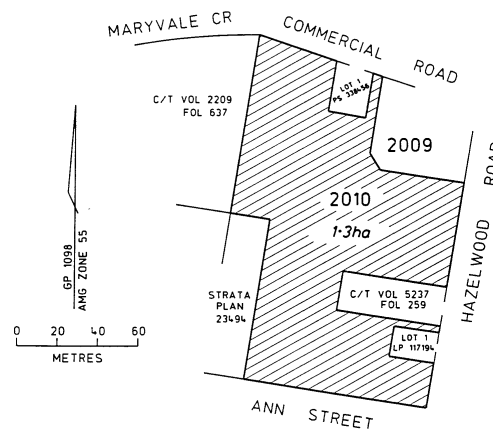

This Order is effective from the date on which it is published in the Government Gazette.

Dated 24 June 2003

Responsible Minister
MARY DELAHUNTY
Minister for Planning

HELEN DOYE
Clerk of the Executive Council

Land Act 1958

CLOSURE OF UNUSED ROAD

The Governor in Council under section 349 of the **Land Act 1958** and with the concurrence in writing of the municipality in which the road is situated closes the following unused road:

MUNICIPAL DISTRICT OF THE STRATHBOGIE SHIRE COUNCIL

RUFFY — The roads in the Parish of Ruffy being Crown Allotments 2001 and 2002 as indicated by hatching on plan hereunder. — (GP1205) — (09/P180107).

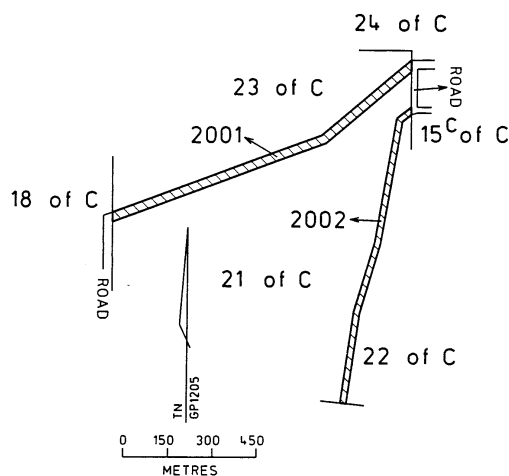

This Order is effective from the date on which it is published in the Government Gazette.

Dated 24 June 2003
 Responsible Minister
MARY DELAHUNTY
 Minister for Planning

HELEN DOYE
 Clerk of the Executive Council

VICTORIA

State Aid to Religion Abolition Act 1871

ACT NO. 391/1871 — SECOND SCHEDULE

A statement of trusts having been submitted by the head or authorised representative of the Uniting Church in Australia under the provisions of the “Act to provide for the abolition of State Aid to Religion” for allowance by the Governor in Council, the same was allowed by him on the twenty-fourth day of June, 2003 and the following is the form in which such statement of trusts has been allowed.

STATEMENT OF TRUSTS

DESCRIPTION OF LAND:—

Site for Presbyterian Church purposes temporarily reserved by Order in Council of 18 December, 1865 being 4046 square metres, Township of Lake Bolac, Parish of Parupa being Crown Allotment 40.

Commencing at the north-eastern angle of Allotment 39, bounded thence by Allotment 39 bearing 184° 30' 40.35 metres; thence by a line bearing 90° 00' 100.58 metres, thence by roads bearing 4° 30' 40.35 metres; and bearing 270° 00' 100.58 metres to the point of commencement.

Site for Presbyterian Church purposes temporarily reserved by Order in Council of 18 December, 1865 being 4046 square metres, Township of Lake Bolac, Parish of Parupa being Crown Allotment 41.

Commencing at the north-western angle of Allotment 42, bounded thence by Allotment 42 bearing 90° 00' 100.58 metres; thence by a road bearing 4° 30' 40.35 metres, thence by a line bearing 270° 00' 100.58 metres; and thence by Allotment 39 bearing 184° 30' 40.35 metres to the point of commencement.

NAME OF TRUSTEES:—

The Uniting Church in Australia Property Trust (Victoria).

POWERS OF DISPOSITION:—

Such powers of disposition including powers of sale, lease or mortgage as are given to the Trustees by the **Uniting Church in Australia Act No. 9021 of 1977** as amended.

PURPOSES TOWARDS WHICH PROCEEDS OF DISPOSITION ARE TO BE APPLIED:—

To such Uniting Church in Australia purposes as shall be approved by the Synod of Victoria of the Uniting Church in Australia.

This Order is effective from the date on which it is published in the Government Gazette.

Dated 24 June 2003
 Responsible Minister
MARY DELAHUNTY
 Minister for Planning

HELEN DOYE
 Clerk of the Executive Council

VICTORIA

State Aid to Religion Abolition Act 1871

ACT NO. 391/1871 — SECOND SCHEDULE

A statement of trusts having been submitted by the head or authorised representative of the Uniting Church in Australia under the provisions of the “Act to provide for the abolition of State Aid to Religion” for allowance by the Governor in Council, the same was allowed by him on the twenty-fourth day of June, 2003 and the following is the form in which such statement of trusts has been allowed.

STATEMENT OF TRUSTS

DESCRIPTION OF LAND:—

Site for Wesleyan Place of Public Worship temporarily reserved by Order in Council of 25 January, 1870 being 4047 square metres, Parish of Conewarre being Crown Allotment B5, Section 21.

Commencing at the north-western angle of allotment B6, section 21; bounded thence by a road bearing 338° 30' 50.29 metres; thence by allotment B1, bearing 68° 30' 80.47 metres; thence by that allotment and a road bearing 158° 30' 50.29 metres, and thence by allotment B6 bearing 248° 30' 80.47 metres to the point of commencement.

NAME OF TRUSTEES:—

The Uniting Church in Australia Property Trust (Victoria).

POWERS OF DISPOSITION:—

Such powers of disposition including powers of sale, lease or mortgage as are given to the Trustees by the **Uniting Church in Australia Act No. 9021 of 1977** as amended.

PURPOSES TOWARDS WHICH PROCEEDS OF DISPOSITION ARE TO BE APPLIED:—

To such Uniting Church in Australia purposes as shall be approved by the Synod of Victoria of the Uniting Church in Australia.

This Order is effective from the date on which it is published in the Government Gazette.

Dated 24 June 2003

Responsible Minister
MARY DELAHUNTY
Minister for Planning

HELEN DOYE
Clerk of the Executive Council

South Melbourne Land Act 1986

CLOSURE OF ROAD

The Governor in Council under section 4(2) of the **South Melbourne Land Act 1986** closes the following road:

MUNICIPAL DISTRICT OF THE
MELBOURNE CITY COUNCIL

SOUTH MELBOURNE — The road in the City of South Melbourne, Parish of Melbourne South being Crown Allotment 2035 as indicated by hatching on plan hereunder. — (GP1197) — (DTF/2001/01791).

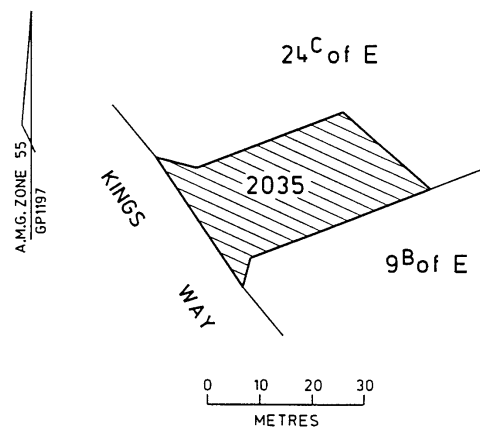

This Order is effective from the date on which it is published in the Government Gazette.

Dated 24 June 2003

Responsible Minister
MARY DELAHUNTY
Minister for Planning

HELEN DOYE
Clerk of the Executive Council

Electricity Industry Act 2000

ORDER UNDER SECTION 14(3)(aa)

Order in Council

The Governor in Council, acting under section 14(3)(aa) of the **Electricity Industry Act 2000** (“the Act”), and on the recommendation of the Minister for Energy Industries, amends the Victorian Electricity Supply Industry Tariff Order made under section 158A(1) of the **Electricity Industry Act 1993** on 20 June 1995 as follows:

- (i) for clause 4.5.1 of the Victorian Electricity Supply Industry Tariff Order substitute:

“4.5.1 Clauses 4.1 to 4.4 and clause 4.6, and this clause 4.5, cease to have effect on 30 June 2003.”

The amendment set out in paragraph (i) comes into operation on the day this Order is published in the Government Gazette.

Dated 24 June 2003

Responsible Minister
THEO THEOPHANOUS
Minister for Energy Industries

HELEN DOYE
Clerk of the Executive Council

Electricity Safety Act 1998

ACCEPTANCE OF ELECTRICITY SAFETY MANAGEMENT SCHEME

Order in Council

The Governor in Council in the exercise of the powers under section 111 (2) of the **Electricity Safety Act 1998**, hereby accepts the Electricity Safety Management Scheme submitted by BHP Steel Limited (application number E4) as provided to the Office of the Chief Electrical Inspector.

Dated 24 June 2003

Responsible Minister:
THEO THEOPHANOUS
Minister for Energy Industries

HELEN DOYE
Clerk of the Executive Council

Electricity Safety Act 1998

ACCEPTANCE OF ELECTRICITY SAFETY MANAGEMENT SCHEME

Order in Council

The Governor in Council in the exercise of the powers under section 111 (2) of the **Electricity Safety Act 1998**, hereby accepts the Electricity Safety Management Scheme submitted by PPG Industries Australia Pty Ltd (application number E7) as provided to the Office of the Chief Electrical Inspector.

Dated 24 June 2003

Responsible Minister:
THEO THEOPHANOUS
Minister for Energy Industries

HELEN DOYE
Clerk of the Executive Council

Gas Industry Act 2001

EXEMPTION FROM REQUIREMENT TO OBTAIN LICENCE TO SELL GAS

Order in Council

The Governor in Council in the exercise of the powers under section 24 of the **Gas Industry Act 2001**, hereby exempts Wesfarmers Kleenheat Gas Pty. Ltd. ABN 40 008 679 543 (Kleenheat) from the requirement to obtain a licence to sell gas by retail, either as a principle or agent. This Order is limited to the sale of liquified natural gas (“LNG”), and is subject to the following conditions that Kleenheat:

1. does not introduce or offer LNG for injection into the principal transmission system for natural gas in Victoria;
2. sells LNG only to customers who dispense LNG to their own fleet vehicles, and deliver such LNG by road tanker;
3. will not prevent any other person from entering into commercial arrangements to purchase or sell LNG; and
4. must provide (whether or not through an agent) to the Minister or the Essential Services Commission, any information either entity may require for the reasonable administration of this Order.

This Order comes into effect on the day after it appears in the Victoria Government Gazette.

Dated 24 June 2003

Responsible Minister:
THEO THEOPHANOUS
Minister for Energy Industries

HELEN DOYE
Clerk of the Executive Council

Estate Agents Act 1980

DECLARATION UNDER SECTION 61

The Governor in Council acting under section 61(2) of the **Estate Agents Act 1980** declares North West Country Credit Union Co-operative Ltd (ABN 25 087 651 625) to be an authorised financial institution for the purposes of section 60 of the **Estate Agents Act 1980**.

Dated 17 June 2003

Responsible Minister:
JOHN LENDERS MLC
Minister for Consumer Affairs

BRIAN TUKE
Acting Clerk of the Executive Council

Land Act 1958

CONSENT TO SURRENDER OF LAND VESTED IN A PUBLIC AUTHORITY

Order in Council

The Governor-in-Council, pursuant to Section 22A(1)(a) of the **Land Act 1958** consents to the surrender to the Crown by Victorian Rail Track of the land in the City of Melbourne, Parish of Melbourne North, shown as Lots 2010, 2011 and 2012 on Title Plan TP812195R (copy attached).

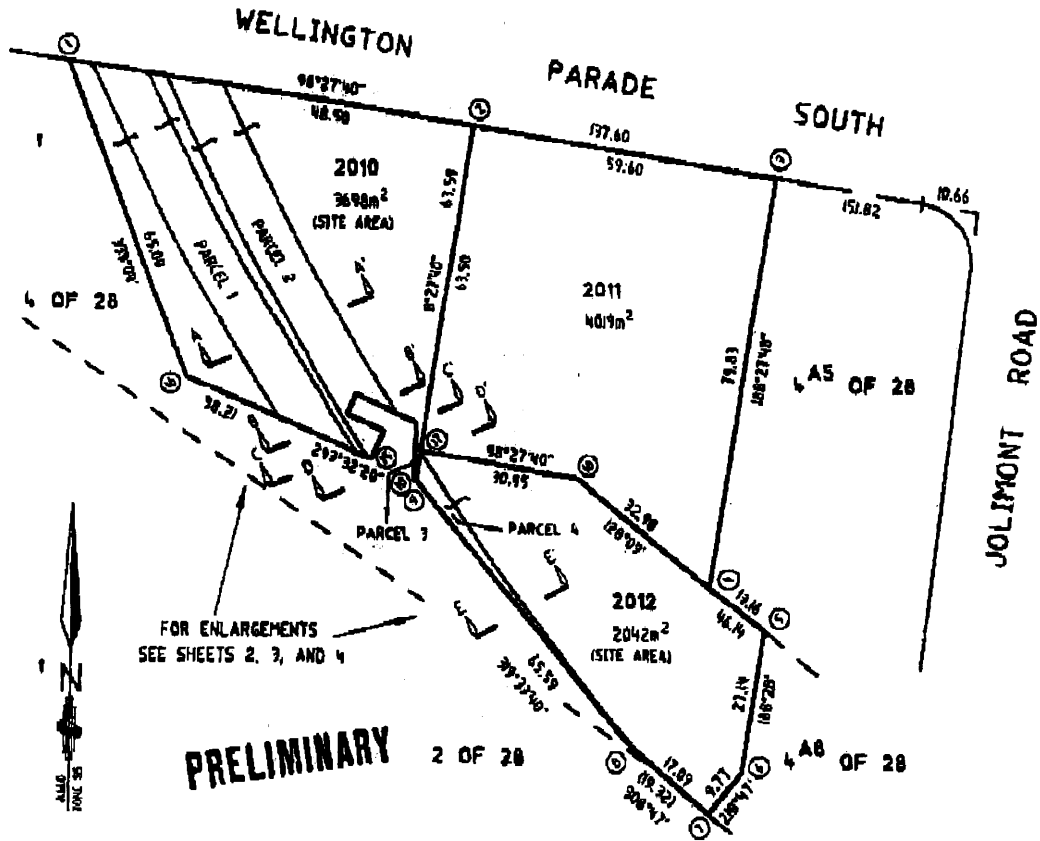

Dated 24 June 2003
Responsible Minister:
JOHN THWAITES, MP
Acting Minister for Planning

HELEN DOYE
Clerk of the Executive Council

Health Services Act 1988

ORDER IN COUNCIL

An Order pursuant to Sections 8(1), 33(7), 34(1) and 65 of the **Health Services Act 1988** ('the Act') in relation to the Amalgamation of Portland and District Hospital and Portland and District Community Health Centre to be known as Portland District Health

The Governor in Council by this Order –

- (a) **directs**, pursuant to section 65(1) of the Act, that Portland and District Hospital and Portland and District Community Health Centre be amalgamated;
- (b) **declares**, pursuant to section 65(4), that the new registered funded agency named Portland District Health shall be a Schedule 1 public hospital;
- (c) **amends** Schedule 1 of the Act such that the name of Portland and District Hospital be removed under section 8(1)(b) of the Act and the name of Portland District Health be added under section 8(1)(a) of the Act and This Order is to take effect on 1 July 2003.

Dated 24 June 2003

Responsible Minister:
HON BRONWYN PIKE MP,
Minister for Health

HELEN DOYE
Clerk of the Executive Council

Pipelines Act 1967

CANCELLATION OF PERMITS AND LICENCES

Order in Council

The Governor in Council cancels the following permits and licences under sections 19 and 29A(c) of the **Pipelines Act 1967** from the date of the Order–

- (a) a Permit to Use and Own a Pipeline 13; and
- (b) a Licence to Construct and Operate a Pipeline 13; and
- (c) a Permit to Use and Own a Pipeline 14; and
- (d) a Licence to Construct and Operate a Pipeline 14; and

- (e) a Permit to Use and Own a Pipeline 56; and
- (f) a Licence to Construct and Operate a Pipeline 56.

Dated 24 June 2003

Responsible Minister
Minister for Resources

HELEN DOYE
Clerk of the Executive Council

Water Industry Act 1994

ORDER SPECIFYING THE AREA WITHIN WHICH A RATE MAY BE MADE AND LEVIED IN RELATION TO LAND

Order in Council

The Governor in Council, under section 139(1A) of the **Water Industry Act 1994**, specifies, for the purpose of section 139(1A) of the **Water Industry Act 1994**, the area described in the Schedule below as the area within which land may be subject to a rate made by the Governor in Council and levied by the Minister responsible for administering the **Water Industry Act 1994**, in respect of the 2003–2004 financial year.

SCHEDULE

The area which is delineated by a heavy black line on the plan numbered LEGL./95-1 and lodged in the Central Plan Office of the Department of Sustainability and Environment, with parts of the boundary of the area being more particularly defined by heavy black delineation on the plans numbered –

LEGL./95-2	LEGL./95-20
LEGL./95-3	LEGL./95-21
LEGL./95-4	LEGL./95-22
LEGL./95-5	LEGL./95-23
LEGL./95-6	LEGL./95-24
LEGL./95-7	LEGL./95-25
LEGL./95-8	LEGL./95-26
LEGL./95-9	LEGL./95-27
LEGL./95-10	LEGL./95-28
LEGL./95-11	LEGL./95-29
LEGL./95-12	LEGL./95-30
LEGL./95-13	LEGL./95-31
LEGL./95-14	LEGL./95-32
LEGL./95-15	LEGL./95-33
LEGL./95-16	LEGL./95-34
LEGL./95-17	LEGL./95-35
LEGL./95-18	LEGL./95-36
LEGL./95-19	LEGL./95-37

– and lodged in the Central Plan Office of the Department of Sustainability and Environment.

Dated 24 June 2003

Responsible Minister:
JOHN THWAITES MP
Minister for Environment

HELEN DOYE
Clerk of the Executive Council

Water Industry Act 1994

ORDER SPECIFYING THE RATE WHICH
THE MINISTER MAY LEVY

Order in Council

The Governor in Council, under section 139(1A) of the **Water Industry Act 1994**, specifies, in respect of the 2003–2004 financial year, 0.29 cents per dollar net annual value or \$46.70 (whichever is the greater amount) as the rate that the Minister responsible for administering the **Water Industry Act 1994** may levy in relation to land within any area or areas specified under section 139(1A) of the **Water Industry Act 1994**.

Dated 24 June 2003

Responsible Minister:
JOHN THWAITES MP
Minister for Environment

HELEN DOYE
Clerk of the Executive Council

This page left blank intentionally

**SUBORDINATE LEGISLATION ACT 1994
NOTICE OF MAKING OF STATUTORY
RULES**

Notice is hereby given under Section 17 (2) of the **Subordinate Legislation Act 1994** of the making of the following Statutory Rules:

69. *Statutory Rule:* Supreme Court (Sheriff's Fees) (Amendment) Regulations 2003
Authorising Act: Supreme Court Act 1986
Date of making: 24 June 2003
70. *Statutory Rule:* County Court (Bailiff's Fees) (Amendment) Order 2003
Authorising Act: County Court Act 1958
Date of making: 24 June 2003
71. *Statutory Rule:* Magistrates' Court (Civil Jurisdiction) (Sheriff's Fees) (Amendment) Regulations 2003
Authorising Act: Magistrates' Court Act 1989
Date of making: 24 June 2003
72. *Statutory Rule:* Electricity Safety (Bushfire Mitigation) Regulations 2003
Authorising Act: Electricity Safety Act 1998
Date of making: 24 June 2003
73. *Statutory Rule:* Electricity Industry (Prohibited Interest) Regulations 2003
Authorising Act: Electricity Industry Act 2000
Date of making: 24 June 2003
74. *Statutory Rule:* National Parks (Park) Regulations 2003
Authorising Act: National Parks Act 1975
Date of making: 24 June 2003
75. *Statutory Rule:* Environment Protection (Fees) (Amendment) Regulations 2003
Authorising Act: Environment Protection Act 1970
Date of making: 24 June 2003
76. *Statutory Rule:* Gaming Machine Control (Loyalty Schemes) Regulations 2003
Authorising Act: Gaming Machine Control Act 1991
Date of making: 24 June 2003
77. *Statutory Rule:* Pathology Services (Exempted Tests) (Amendment) Regulations 2003
Authorising Act: Pathology Services Accreditation Act 1984
Date of making: 24 June 2003
78. *Statutory Rule:* Pathology Services Accreditation (General) (Amendment) Regulations 2003
Authorising Act: Pathology Services Accreditation Act 1984
Date of making: 24 June 2003
79. *Statutory Rule:* Building (Application of Siting Requirements) Regulations 2003
Authorising Act: Building Act 1993
Date of making: 24 June 2003
80. *Statutory Rule:* Land Tax (Amendment) Regulations 2003
Authorising Act: Land Tax Act 1958
Date of making: 24 June 2003
81. *Statutory Rule:* Victorian Civil and Administrative Tribunal (Amendment No. 11) Rules 2003
Authorising Act: Victorian Civil and Administrative Tribunal Act 1998
Date of making: 25 June 2003

**SUBORDINATE LEGISLATION ACT 1994
NOTICE THAT STATUTORY RULES ARE
OBTAINABLE**

Notice is hereby given under Section 17 (3) of the **Subordinate Legislation Act 1994** that the following Statutory Rules were first obtainable from Information Victoria, 356 Collins Street, Melbourne on the date specified:

- | | | | | | | | |
|----------------------------|------------------------------------------------------------------------------------------------------------------------------|-------------------------|---------------------------------------------------|-------------------------------|--------------|---------------|--|
| 61. <i>Statutory Rule:</i> | Magistrates' Court (Arbitration) (Professional Costs) Regulations 2003 | <i>Authorising Act:</i> | Magistrates' Court Act 1989 | <i>Date first obtainable:</i> | 26 June 2003 | <i>Code A</i> | |
| 62. <i>Statutory Rule:</i> | Subordinate Legislation (Freedom of Information (Access Charges) Regulations 1993 – Extension of Operation) Regulations 2003 | <i>Authorising Act:</i> | Subordinate Legislation Act 1994 | <i>Date first obtainable:</i> | 26 June 2003 | <i>Code A</i> | |
| 63. <i>Statutory Rule:</i> | Liquor Control Reform (Prohibited Class of Liquor) Regulations 2003 | <i>Authorising Act:</i> | Liquor Control Reform Act 1998 | <i>Date first obtainable:</i> | 26 June 2003 | <i>Code A</i> | |
| 64. <i>Statutory Rule:</i> | Health (Pest Control) (Fees) Regulations 2003 | <i>Authorising Act:</i> | Health Act 1958 | <i>Date first obtainable:</i> | 26 June 2003 | <i>Code A</i> | |
| 65. <i>Statutory Rule:</i> | Health (Radiation Safety) (Fees) Regulations 2003 | <i>Authorising Act:</i> | Health Act 1958 | <i>Date first obtainable:</i> | 26 June 2003 | <i>Code A</i> | |
| 66. <i>Statutory Rule:</i> | Health (Medical Radiation Technologists) (Fees) Regulations 2003 | <i>Authorising Act:</i> | Health Act 1958 | <i>Date first obtainable:</i> | 26 June 2003 | <i>Code A</i> | |
| 67. <i>Statutory Rule:</i> | Drugs, Poisons and Controlled Substances (Fees) Regulations 2003 | <i>Authorising Act:</i> | Drugs, Poisons and Controlled Substances Act 1981 | <i>Date first obtainable:</i> | 26 June 2003 | <i>Code A</i> | |
| 68. <i>Statutory Rule:</i> | Health Services (Supported Residential Services) (Fees) Regulations 2003 | <i>Authorising Act:</i> | Health Services Act 1988 | <i>Date first obtainable:</i> | 26 June 2003 | <i>Code A</i> | |

**PRICING FOR SPECIAL GAZETTE,
PERIODICAL GAZETTE AND VICTORIAN
LEGISLATION**

Retail price varies according to the number of pages in each Victoria Government Special Gazette, Victoria Government Periodical Gazette and Victorian legislation. The table below sets out the prices that apply.

<i>Price Code</i>	<i>No. of Pages (Including cover and blank pages)</i>	<i>Price*</i>
A	1–16	\$3.65
B	17–32	\$5.40
C	33–48	\$7.40
D	49–96	\$11.50
E	97–144	\$14.85
F	145–192	\$17.55
G	193–240	\$20.25
H	241–288	\$21.55
I	289–352	\$24.25
J	353–416	\$28.35
K	417–480	\$32.35
L	481–544	\$37.75
M	545–608	\$43.15
N	609–672	\$48.55
O	673–736	\$53.90
P	737–800	\$59.30

**All Prices Include GST*

ADVERTISERS PLEASE NOTE

As from 26 June 2003

The last Special Gazette was No. 123 dated 25 June 2003

The last Periodical Gazette was No. 1 dated 12 June 2003

CONTENTS

	Page
Estates of Deceased Persons	1481
Government and Outer Budget Sector	
Agencies Notices	1549
Orders in Council	1600
Acts — Administrative Arrangements;	
Cemeteries; Control of Weapons;	
Crown Land (Reserves);	
Electricity Industry; Electricity Safety;	
Estate Agents; Gas Industry;	
Health Services; Land; Pipelines;	
South Melbourne Land;	
State Aid to Religion Abolition;	
Water	
Private Advertisements	1481
Proclamations	1548

The Victoria Government Gazette is published by The Craftsman Press Pty. Ltd. with the authority of the Government Printer for the State of Victoria
© State of Victoria 2003

ISSN 0819-5471

This publication is copyright. No parts may be reproduced by any process except in accordance with the provisions of the Copyright Act.

Products and services advertised in this publication are not endorsed by The Craftsman Press Pty. Ltd. or the State of Victoria and neither of them accepts any responsibility for the content or the quality of reproduction. The Craftsman Press Pty. Ltd. reserves the right to reject any advertising material it considers unsuitable for government publication.

Address all enquiries to the
Government Printer for the State of Victoria
Level 2 1 Macarthur Street
Melbourne 3002
Victoria Australia

RETAIL SALES

Information Victoria Bookshop
356 Collins Street Melbourne 3000.
Telephone enquiries 1300 366 356

City Graphics
Level 1, 520 Bourke Street
Melbourne 3000
Telephone enquiries (03) 9600 0977

Recommended Retail Price \$1.95 (includes GST)

Government and Outer Budget Sector Agencies please note:
STYLE REQUIREMENTS.

To ensure that material received can be reproduced, and that errors are minimised, the following guidelines are to be observed when submitting material by fax.

Fax resolution:

Material sent by fax should be transmitted using Fine Resolution (200 dots per inch by 200 dpi).

Font size:

Use 12 point (10 pitch) or larger.

Font Style:

Clear plain font styles, such as Helvetica, should be used.

Graphics:

Line drawings should be transmitted as large as possible to ensure clarity. Drawings up to A4 size sent by fax using Fine Resolution provide a good quality for reproduction.

Avoid:

Italics, underlining and full justification.

Ensure document is square when sending as documents that are sent skewed are difficult to read and process.

ISSN 0819-5471



9 770819 549816