



# Victoria Government Gazette

By Authority of Victorian Government Printer

**No. G 14 Thursday 1 April 2004**

[www.gazette.vic.gov.au](http://www.gazette.vic.gov.au)

**GENERAL**

---

**TABLE OF PROVISIONS**

Private Advertisements	704	Unclaimed Moneys	
Dissolution of Partnerships		Berklee Limited	709
One Zach Bright	704	UCA Funds Management Victoria	709
Lighthouse Stables Tea Room and Gallery	704	Troy Resources NL	710
Estates of Deceased Persons		Proclamations	714
Chessell Williams	704	Government and Outer Budget Sector	
Ellinghaus Weill	704	Agencies Notices	715
Garden & Green	704	Orders in Council	739
Gray Friend & Long	704	Acts: Children and Young Persons;	
Harris & Chambers	705	Crown Land (Reserves);	
J.P. Donald & Ryan	705	Electricity Industry;	
John Stewart	705	Land;	
Kelly & Chapman	705	Parliamentary Committees;	
Littleton Hackford	705	Racing;	
Mark G. Bramich	706	Taxation (Reciprocal Powers)	
Pearce Webster Dugdales	706	Victorian Plantations	
Pietrzak	706	Corporation	
Rennick & Gaynor	706		
Stidston & Williams Weblaw	706		
Taylor Whelan & Whelan	706		
Tolhurst Druce & Emmerson	707		
Sales by the Sheriff			
Francesco (Frank) Pascuzzi	707		
Thomas Lee	707		
Bradley Stewart	707		
Denis Roy Shaw	707		
Judith Leanne Hawes	708		
Henry Hey	708		
Leonard Alfred Teelow	708		

---

**Advertisers Please Note**

As from 1 April 2004

The last Special Gazette was No. 80 dated 31 March 2004.

The last Periodical Gazette was No. 1 dated 12 June 2003.

---



---

**How To Submit Copy**

- See our webpage [www.craftpress.com.au](http://www.craftpress.com.au)
  - or contact our office on 9926 1233  
between 8.30 am and 5.30 pm Monday to Friday
- 

---

**Copies of recent Special Gazettes can now be viewed at the following display cabinets:**

- 1 Treasury Place, Melbourne (behind the Old Treasury Building), and
  - Craftsman Press Pty Ltd, 125 Highbury Road, Burwood 3125 (front of building).
-

**PUBLICATION OF THE VICTORIA GOVERNMENT GAZETTE (GENERAL)  
EASTER HOLIDAYS**

**Please Note:**

The Victoria Government Gazette for Easter week will be published on **Thursday 15 April 2004.**

**Copy deadlines:**

Private Advertisements **9.30 am on Thursday 8 April 2004.**

Government and Outer  
Budget Sector Agencies Notices **9.30 am on Tuesday 13 April 2004.**

Where urgent gazettal is required after hours, arrangements should be made with the Government Gazette Officer on 0419 327 321.

JENNY NOAKES  
Government Gazette Officer

---

### PRIVATE ADVERTISEMENTS

#### DISSOLUTION OF PARTNERSHIP

Neil Robert James McDonald, Aileen June McDonald, William Gerard Melbourne, Jennifer May Melbourne and Shelley Lee Payne wish to advise in accordance with Section 41 of the **Partnership Act 1958**, that the partnership formerly conducted by them under the name of ONE ZACH BRIGHT has been dissolved effective as at 19 March 2004, and that Neil Robert James McDonald, Aileen June McDonald, William Gerard Melbourne, and Jennifer May Melbourne have entered into a new partnership and will continue to operate under the name of ONE ZACH BRIGHT.

HARGRAVES, solicitors,  
81 Belmore Street, Yarrowonga.

---

#### DISSOLUTION OF PARTNERSHIP

Notice is hereby given in accordance with the provisions of the **Partnership Act 1958** that the partnership between Lindy Whelan of 17 Robertson Crescent, Boronia, Victoria 3155 and Duane Cambell Whelan of 21 Amaroo Crescent, Aireys Inlet, Victoria 3231 carrying on a tea room and gallery business at 7 Federal Street, Aireys Inlet, Victoria 3231 under the name of "Lighthouse Stables" Tea Room and Gallery was dissolved on 30 September 2003. Duane Cambell Whelan will continue to carry on the partnership business as Lindy Whelan resigned from the partnership.

---

Re: VICTORIA MARTHA MACKENZIE.

Creditors, next-of-kin and others having claims against the estate of VICTORIA MARTHA MACKENZIE, late of 55 Inverness Way, North Balwyn, Victoria, widow, deceased, who died on 1 May 2002, are requested to send particulars of their claims to the executor care of the undermentioned solicitors by 10 June 2004, after which date he will distribute the assets having regard only to the claims on which date he then has notice.

CHESSELL WILLIAMS, solicitors,  
379 Collins Street, Melbourne 3000.

---

Re: Estate of MARGERY JOYCE PHILPOTT.

Creditors, next-of-kin and others having claims against the estate of MARGERY JOYCE PHILPOTT, late of Darnlee Aged Care, 33 Lansell Road, Toorak, Victoria, widow, deceased, who died on 6 December 2003, are requested to send particulars of their claims to the executor care of the undermentioned solicitors by 1 June 2004, after which date he will distribute the assets having regard only to the claims on which date he then has notice.

CHESSELL WILLIAMS, solicitors,  
379 Collins Street, Melbourne 3000.

---

IVA MARGARET HOLT, late of 1 Laurel Court, Hawthorn East, analytical chemist, deceased. Creditors, next-of-kin and others having claims in respect of the estate of the deceased, who died on 27 November 2003, are required by the personal representative, James Holt of 1 Laurel Court, Hawthorn East, to send particulars to him care of the undermentioned solicitors by 9 June 2004 after which date the personal representative may convey or distribute the assets having regard only to the claims of which he then has notice.

ELLINGHAUS WEILL, solicitors,  
79-81 Franklin Street, Melbourne 3000.

---

Re: THELMA MARGARET LEECH, deceased.

Creditors, next-of-kin and others having claims in respect of the estate of the deceased, who died on 2 December 2001, are required by the trustee, Hugh George Leech, to send particulars to him by 2 June 2004 after which date the trustee may convey or distribute the assets, having regard only to the claims of which he then has notice.

GARDEN & GREEN, solicitors,  
4 McCallum Street, Swan Hill 3585.

---

JAMES PATRICK FAWKNER, late of 7 Campbell Street, Garfield, Victoria, retired butcher, deceased.

Creditors, next-of-kin and others having claims in respect of the estate of the deceased, who died on 23 December 2003, are required by the trustee, Carmel Patricia Fawkner, the executrix of the Will of the deceased, to send particulars of their claims to her care of the undersigned solicitors by 31 May 2004 after which date the trustee may convey or distribute the assets having regard only to the claims of which she then has notice.

GRAY FRIEND & LONG, solicitors,  
70 Queen Street, Warragul 3820.

---

DOROTHY ANNE FITZGERALD, late of 22 Spicer Street, Beaumaris, home duties, deceased.

Creditors, next-of-kin and others having claims in respect of the estate of the deceased, who died on 10 December 2003, are required by the trustee, care of Harris & Chambers lawyers of 338 Charman Road, Cheltenham, to send particulars to him by 2 June 2004 after which date the trustee may convey or distribute the assets, having regard only to the claims of which he then has notice.

HARRIS & CHAMBERS, lawyers,  
338 Charman Road, Cheltenham 3192.

---

Creditors, next-of-kin and others having claims in respect of the estate of LLOYD EDWIN BRIGGS, late of 139 Fordham Avenue, Camberwell, in the said State, retired carpenter, deceased, who died on 15 June 2003, are required by the executor, Albert John Bowden of 70 Jenkins Road, Whittlesea, in the State of Victoria, retired teacher, to send particulars of their claim to him c/- the undermentioned solicitors by 2 June 2004 after which date the said executor will distribute the assets of the deceased having regard only to the claims of which he then shall have notice.

J. P. DONALD & RYAN, solicitors,  
304 High Street, Kew 3101.

---

Creditors, next-of-kin and others having claims in respect of the Will of ALBEIN EMANUEL JOHNSSON, late of 16 Crown Street, Flemington, Victoria, retired, deceased, who died on 15 January 2004, are requested to

send particulars of their claims to the executor, Irene Ursula Johnsson, care of the undermentioned legal practitioner by 2 June 2004 after which date she will distribute the assets having regard only as to the claims of which she then has notice.

JOHN STEWART, legal practitioner,  
290 Racecourse Road, Newmarket.

---

Creditors, next-of-kin and others having claims in respect of the estate of CRAIG LEIGH HOLTON, late of 25 Middleton Street, Highett, in the State of Victoria, construction worker, deceased, who died on 26 November 2003, are required by Elizabeth Lea Morrow of Unit 42, No. 61 Hughes Avenue, Edithvale, in the said State, information technology administrator, an executrix nominated in the deceased's last Will and Testament dated 12 November 2003, who is applying to the Supreme Court for a Grant of Probate of the said last Will and Testament, to send particulars of such claims to the solicitors acting for the said executrix namely Kelly & Chapman, 300 Centre Road, Bentleigh by 10 June 2004, after which date the said executrix may convey or distribute the assets of the deceased, having regard only to the claims of which she or her solicitors then have notice.

KELLY & CHAPMAN, lawyers,  
300 Centre Road, Bentleigh.

---

Creditors, next-of-kin and others having claims in respect of the estate of JOHN DOUGLAS BLACK, late of Mattingley Hill Road, Traralgon South, Victoria, farmer, deceased, who died on 10 May 2003, are to send their claims to the trustees, John Phillip Black of Mattingley Hill Road, Traralgon South, Peter Anthony Black of Hazelwood Road, Traralgon South and Elizabeth Jean Dowling of Andrew Street, Morwell, Victoria, care of the below mentioned solicitors by 31 May 2004 after which date they will distribute the assets of the deceased having regard only to the claims of which they then have notice.

LITTLETON HACKFORD, solicitors,  
Law Chambers,  
115-119 Hotham Street, Traralgon, Vic. 3844.

---

Re: Estate of SHEILA MARGARET SLEEP, deceased.

Creditors, next-of-kin and others having claims in respect of the estate of SHEILA MARGARET SLEEP, late of Unit 165 "Parkglen", 360 Cheltenham Road, Keysborough, in the State of Victoria, retired, deceased, who died on 16 November 2002, are required to send particulars of their claims to the executor, Stanley Francis Jordan, care of the undermentioned lawyer by 1 June 2004 after which date the executor will distribute the assets having regard only to the claims of which he then has notice.

MARK G. BRAMICH, lawyer,  
22 Spring Square, Hallam, Victoria 3803.

Re: CLEMENT JAMES RYAN, late of "Sheridan Hall", 16-24 Castlebar Road, Chadstone, Victoria, but formerly of 2 Alamar Avenue, Glenhuntly, gentleman, deceased.

Creditors, next-of-kin and others having claims in respect of the estate of the deceased, who died on 12 December 2003, are required by the trustee, Hugh Graham Latimer of 83 Neerim Road, Glenhuntly, Victoria, teacher, to send particulars to the trustee by 7 June 2004 after which date the trustee may convey or distribute the assets, having regard only to the claims of which the trustee has notice.

PEARCE WEBSTER DUGDALES, solicitors,  
24 High Street, Glen Iris 3146.

Creditors, next-of-kin and others having claims in respect of the estate of JANINA BALKO-NIWSKI, late of 15 Cluden Street, East Brighton, in the State of Victoria, retired machinist, deceased, who died on 23 February 2004, are required to send particulars of such claims to the administrators care of the undermentioned solicitors by 2 June 2004 after which date the administrators will convey or distribute the assets having regard only to the claims of which the administrators then have notice.

PIETRZAK, solicitors,  
222 La Trobe Street, Melbourne.

DAPHNE MARY JACKETT, late of Samarinda Lodge, 286 High Street, Ashburton, Victoria, home duties, deceased.

Creditors, next-of-kin and others having claims in respect of the estate of the deceased, who died on 17 January 2004, are required by the executors, Barrie Scott Jackett of 35 Milverton Street, Camberwell, Victoria and David Anthony Rush of 431 Riversdale Road, Hawthorn East, Victoria, to send particulars to them (care of the undersigned) by 1 June 2004 after which date the executors may convey or distribute the assets having regard only to the claims of which they then have notice.

RENNICK & GAYNOR, solicitors,  
431 Riversdale Road, Hawthorn East.

MARGARET GERTRUDE KELLY, late of 10 Allen Drive, Mount Eliza, Victoria, deceased.

Creditors, next-of-kin and others having claims in respect of the estate of the deceased, who died on 21 November 2003, are required by the trustee, Elizabeth Mary Kelly of 5/58 Crisp Street, Hampton, Victoria to send particulars to her by 4 June 2004 after which date the trustee may convey or distribute the assets, having regard only to the claims of which she then has notice.

STIDSTON & WILLIAMS WEBLAW,  
solicitors,  
Suite 1, 10 Blamey Place, Mornington.

Re: RUBY EILEEN ALLISON, deceased.

Creditors, next-of-kin or others having claims in respect of the estate of RUBY EILEEN ALLISON, deceased, late of Bethlehem Home for the Aged, Taylor Street, Golden Square, Victoria, retired school teacher, who died on 29 December 2003, are to send particulars of their claim to John Francis Whelan, the executor, care of the undermentioned solicitors by 15 June 2004 after which date the executor will distribute the assets having regard only to the claims of which the executor then has notice.

TAYLOR WHELAN & WHELAN, solicitors,  
13 View Point, Bendigo.  
Telephone: (03) 5441 8766.

Creditors, next-of-kin and others having claims against the estate of JOYCE LILIAN PATTERSON (also known as Joyce Lillian Patterson), late of Goonawarra Nursing Home, 23–25 Anderson Road, Sunbury, Victoria, retired, deceased, who died on 15 January 2004, are required by Patrick Francis Toohey of 23 Epping Street, East Malvern, Victoria, in the said State, to send particulars of their claims to the said Patrick Francis Toohey by 2 June 2004 after which date he will convey or distribute the assets having regard only to the claims of which he then has notice.

TOLHURST DRUCE & EMMERSON,  
solicitors,  
520 Bourke Street, Melbourne

In the County Court of the State of Victoria  
SALE BY THE SHERIFF

To the Highest Bidder at the Best Price Offered

On Wednesday 5 May 2004 at 2.30 p.m. at the Sheriff's Office, 8–20 King Street, Oakleigh. (Unless process be stayed or satisfied).

All the estate and interest (if any) of Francesco (Frank) Pascuzzi of 33 Vanessa Crescent, Mulgrave as shown on Certificate of Title as Francesco Pascuzzi, joint proprietor with Maria Pascuzzi of an estate in fee simple in the land described on Certificate of Title Volume 8970, Folio 395 upon which is erected a residence known as 33 Vanessa Crescent, Mulgrave.

Registered Mortgage No. X433644Y and Caveat No. AB565383W affect the said estate and interest.

No Reserve Set

Terms – Cash/Eftpos

(Debit Card only. No Credit Cards).

CW-03-008265-3

Dated 1 April 2004

V. PARKIN  
Sheriff's Office

In the Supreme Court of the State of Victoria  
SALE BY THE SHERIFF

On Wednesday 5 May 2004 at 2.30 p.m. at the Sheriff's Office, 8–20 King Street, Oakleigh. (Unless process be stayed or satisfied).

All the estate and interest (if any) of Thomas Lee of 2 Yandell Close, Vermont South, as shown on Certificate of Title as Siew Pham Lee, proprietor of an estate in fee simple in the land described on Certificate of Title Volume 9194, Folio 320 upon which is erected a house known as 2 Yandell Close, Vermont South.

Registered Mortgage No. AB570004E affects the said estate and interest.

Terms – Cash/Eftpos

(Debit Cards only. No Credit Cards).

SW-03-009450-0

Dated 1 April 2004

V. PARKIN  
Sheriff's Office

In the Supreme Court of the State of Victoria  
SALE BY THE SHERIFF

On Wednesday 5 May 2004 at 2.30 p.m. at the Sheriff's Office, 8–20 King Street, Oakleigh. (Unless process be stayed or satisfied).

All the estate and interest (if any) of Bradley Stewart of 6 Joyce Court, Bayswater, as shown on Certificate of Title as Bradley Charles Stewart, joint proprietor with Marlene Dawn Smith of an estate in fee simple in land described on Certificate of Title Volume 10357, Folio 861 upon which is erected a dwelling known as 6 Joyce Court, Bayswater.

Registered Mortgage No. V260289V and Planning Agreement U187254H affect the said estate and interest.

Terms – Cash/Eftpos

(Debit Cards only. No Credit Cards).

SW-03-004361-4

Dated 1 April 2004

V. PARKIN  
Sheriff's Office

In the Supreme Court of the State of Victoria  
SALE BY THE SHERIFF

On Wednesday 5 May 2004 at 2.30 p.m. at the Sheriff's Office, 8–20 King Street, Oakleigh. (Unless process be stayed or satisfied).

All the estate and interest (if any) of Denis Roy Shaw of 3 Chestfield Court, Frankston, proprietor of an estate in fee simple in the land described on Certificate of Title Volume 8890,

Folio 114 upon which is erected a house known as 3 Chestfield Court, Frankston.

Registered Mortgage No. T929950F affects the said estate and interest.

Terms – Cash/Eftpos  
(Debit Card only. No Credit Cards).  
SW-03-009478-6

Dated 1 April 2004

V. PARKIN  
Sheriff's Office

In the Supreme Court of the State of Victoria

SALE BY THE SHERIFF

On Thursday 6 May 2004 at 11.00 a.m. at the Sheriff's Office, 3/148 Welsford Street, Shepparton. (Unless process be stayed or satisfied).

All the estate and interest (if any) of Judith Leanne Hawes of 70 Stanhope Road, Rushworth, joint proprietor with Barry Lauchlan Hawes of an estate in fee simple in the land described on Certificate of Title Volume 10442, Folio 218 upon which is erected a house known as 70 Stanhope Road, Rushworth.

Registered Mortgage No. V898717D affects the said estate and interest.

Terms – Cash only  
SW-03-009302-6

Dated 1 April 2004

V. PARKIN  
Sheriff's Office

In the Supreme Court of the State of Victoria

SALE BY THE SHERIFF

On Friday 7 May 2004 at 11.00 a.m. at the Sheriff's Office, corner of Little Malop & Fenwick Streets, Geelong. (Unless process be stayed or satisfied).

All the estate and interest (if any) of Henry Hey of 675 Ballarat Road, Batesford as shown on Certificate of Title as Henry Carl Hey, proprietor of an estate in fee simple in the land described on Certificate of Title Volume 9617, Folio 451 upon which is erected a dwelling known as 14 Warrak Drive, Bannockburn.

Registered Covenant M100454G affects the said estate and interest.

Travel to the township of Bannockburn then travel in a northerly direction along Clyde Road turning left into Lowndes Road, then right into Warrak Drive, the property is located on the western side of Warrak Drive.

Refer RACV VicRoads Edition 4, Map 295 M2.

Terms – Cash only  
SW-03-005415-2

Dated 1 April 2004

V. PARKIN  
Sheriff's Office

In the Supreme Court of the State of Victoria

SALE BY THE SHERIFF

On Friday 7 May 2004 at 11.00 a.m. at the Sheriff's Office, corner of Little Malop & Fenwick Streets, Geelong. (Unless process be stayed or satisfied).

All the estate and interest (if any) of Henry Carl Hey of 675 Ballarat Road, Batesford, joint proprietor with Werner Karl Hey, Elsa Maria Annette Hey and Marion Jane Hey of an estate in fee simple in the land described on Certificate of Title Volume 9042, Folio 982 upon which is erected a dwelling known as 675 Ballarat Road, Batesford.

Terms – Cash only  
SW-03-006856-2

Dated 1 April 2004

V. PARKIN  
Sheriff's Office

In the Supreme Court of the State of Victoria

SALE BY THE SHERIFF

On Friday 7 May 2004 at 11.00 a.m. at the Sheriff's Office, corner of Fenwick & Little Malop Streets, Geelong. (Unless process be stayed or satisfied).

All the estate and interest (if any) of Leonard Alfred Teelow of 83 Cox Street, Penshurst, joint proprietor with Pauline June Teelow of an estate in fee simple in the land described on Certificate of Title Volume 9489, Folio 356 upon which is erected a house known as 83 Cox Street, Penshurst.

The property can be located by travelling from Geelong in a westerly direction along the



Hamilton Highway to Mortlake, continue in a north westerly direction along the Hamilton Highway to Penshurst, the property is located in the township of Penshurst.

Registered Mortgage No. T682660T affects the said estate and interest.

Terms – Cash only

SW-01-010712-8

Dated 1 April 2004

V. PARKIN  
Sheriff's Office

### Unclaimed Moneys Act 1962

Register of Unclaimed Moneys held by the —

<i>Name of Owner on Books and Last Known Address</i>	<i>Total Amount Due to Owner</i>	<i>Description Of Unclaimed Money</i>	<i>Date when Amount first became Payable</i>
BERKLEE LIMITED			
	\$		
Throsby Investments Pty Ltd, 5 St Mervyns Avenue, Point Piper, NSW	700.00	Cheque	30/04/02
Suleikha Prior, 96 Mann Street, Armidale, NSW	160.00	"	"
Michael Burt, 7/52 Canterbury Road, Middle Park	120.00	"	"
Throsby Investments Pty Ltd, 5 St Mervyns Avenue, Point Piper, NSW	700.00	"	28/10/02
Michael Burt, 7/52 Canterbury Road, Middle Park	120.00	"	"

04051

CONTACT: WAYNE LAWES. PHONE: (03) 5338 1110.

### Unclaimed Moneys Act 1962

Register of Unclaimed Moneys held by the —

<i>Name of Owner on Books and Last Known Address</i>	<i>Total Amount Due to Owner</i>	<i>Description Of Unclaimed Money</i>	<i>Date when Amount first became Payable</i>
UCA FUNDS MANAGEMENT VICTORIA			
	\$		
Estate of Janet Saxe, 19 Ballymore Court, Frankston	360.05	Cheque	01/01/03

04046

CONTACT: PAULINE GIBBS, PHONE: (03) 9251 5225.

**Unclaimed Moneys Act 1962**

Register of Unclaimed Moneys held by the —

<i>Name of Owner on Books and Last Known Address</i>	<i>Total Amount Due to Owner</i>	<i>Description Of Unclaimed Money</i>	<i>Date when Amount first became Payable</i>
TROY RESOURCES NL			
	\$		
Herser Investments Ltd, 108 Brighton Road, Scarborough, WA	1,911.00	Cheque	31/03/01
Alan Weller, Embassy Hotel, Edward Street, Brisbane, Qld	292.74	"	11/03/00
Allan Robert Wilson, 42/68 McMaster Street, Victoria Park, WA	292.74	"	"
Alwyn Arthur, 8 Nyorie Place, Frenchs Forest, NSW	312.42	"	"
Andrew David Bennier, 29 Rand Avenue, Safety Bay, WA	292.74	"	"
Andrew Pakioufakis, 1/276 Cambridge Street, Wembley, WA	190.50	"	"
Angela May Phipps, Unit 2, 76 Waverley Road, Chadstone	292.74	"	"
B. C. Barron, 17 Suelin Street, Boondall, Qld	146.05	"	"
Bert Bradley Scally, Lot 26 Hadrill Road, Baskerville, WA	116.84	"	"
Bradley Grant Tanner, 70 Eucalyptus Avenue, Annandale, Qld	305.44	"	"
Brian Alwyn Rogers, 204 London Road, Belmont, Qld	175.90	"	"
Brian David Weller, C/- Embassy Hotel, corner of Edward & Elizabeth Streets, Brisbane, Qld	292.74	"	"
Brian Edward Henneker, 2 Hartrey Lane, Kalgoorlie, WA	234.32	"	"
Brian James Drysdale, C/- Smith Martis Cork & Rajan, PO Box 844, Subiaco, WA	351.79	"	"
Carol K. Temple, 20 Autumnwood Ct, The Woodlands, Texas 77380, United States of America	194.95	"	"
Carolyn Maree Matera, 11 Bowman Court, Kardinya, WA	468.63	"	"
Cheryl Rei & Trevor Simpson, 18 Berryman Street, North Ryde, NSW	468.63	"	"
Chong Jin Wee, 1 Colombo Court, 617 Singapore	273.05	"	"
Craig Douglas Wood, PO Box 398, Kalgoorlie, WA	116.84	"	"
Cynthia Cosstick, 6 Stanton Terrace North Ward, Qld	292.74	"	"
Daryl Morse-Evans & Mrs Helen Morse-Evans, 12 Lana Court, Rossmoyne, WA	317.50	"	"
David John Satchell, 7 Duxford Street, Paddington, NSW	205.11	"	"
David Jones, 8B Markham Avenue, Runaway Bay, Qld	439.42	"	"
David Potter, 24 Lewin Way, Scarborough, WA	321.95	"	"
Derek O'Connell, PO Box 407, Newman, WA	146.05	"	"
Derrick Albert Sambrook, 5 Otter Court, Willetton, WA	439.42	"	"
Domingo Martinez, 8 Burton Street, Hermit Park, Qld	208.28	"	"
Earl Owen, 1 Esther Street, Surry Hills, NSW	194.95	"	"
Eleanor Ma, 36 Arterial Road, Killara, NSW	321.95	"	"
Frank Menzies, 1 Queen Victoria Mews, 479 Elizabeth Street, Melbourne	439.42	"	"

Gacel Holdings Pty Ltd, C/- Bailey Associates, 8th Floor, 39/41 York Street, Sydney, NSW	194.95	''	''
Geoffrey Michael Luck, "The Luck Family Account", 20 Edward Street, Sorrento, WA	102.24	''	''
Geoffrey William Smiley & Margaret Maud Smiley, 35 MacDonald Street, Lota, Qld	194.95	''	''
George Edward Roberts, PO Box 1115, Geraldton, WA	292.74	''	''
Glenn Sampson & Ms Vanessa Sampson, 14 Bluestone Walk, Delahey	228.60	''	''
Gold Corporation of Australia Pty Ltd, GPO Box 1013H, Melbourne	390.53	''	''
Gordon Taylor, C/- Stegmans, Terranora Road, Terranora, NSW	292.74	''	''
Gregory David Pearce, 5 Merrigum Court, Doncaster	146.05	''	''
Ira Johnsen, 88 Arthur Street, Surry Hills, NSW	146.05	''	''
Irene Mary Jones, PO Box 246, Kalgoorlie, WA	439.42	''	''
Jean Louis Pradie, 8/178 Beach Street, Coogee, NSW	439.42	''	''
Jeffrey Dewar, C/- Box 61, Broome Hill, WA	292.74	''	''
Jeffrey Scott Davidson, 9/171 Hector Street, Osborne Park, WA	234.32	''	''
Jennifer Lynette White, 35 Marmion Street, North Perth, WA	439.42	''	''
Joanne Dore, 9 Balmoral Way, Kallaroo, WA	439.42	''	''
John Abbott, 68 Sirius Street, Southern Cross, WA	468.63	''	''
John Roger Smalley, 29 Chelmsford Road, Mount Lawley, WA	292.74	''	''
Jonathan Lechte, "Harrison Jon Lechte A/c", 15 Woodstock Street, Bondi Junction, NSW	146.05	''	''
Jonathan Lechte, "Maxwell Alexander Lechte A/c", 15 Woodstock Street, Bondi Junction, NSW	146.05	''	''
Justin Heath Ridley, 14 The Grove, Wembley, WA	146.05	''	''
Justine Lisa McArthur, 1 Ulolia Avenue, Hornsby Heights, NSW	146.05	''	''
Kathleen Anne Dillon, C/- B. Bailey & Associates, GPO Box 230, Sydney, NSW	194.95	''	''
Keith Murray, 8B Markham Avenue, Runaway Bay, Qld	439.42	''	''
Kenneth Connolly & Rita Connolly, 15 Beira Street, Aspley, Qld	130.18	''	''
Kevin John Moss & Vivian Sylvia Moss, 20 Shimmers Green, Clarkson, WA	292.74	''	''
Lee Gardner, 207 Duke Street, Scarborough, WA	234.32	''	''
Leon Denehey, 5 Campaspe Court, Kambalda, WA	439.42	''	''
Liang Gen Want, Unit 7/33 Camden Street, Dianella, WA	439.42	''	''
Lina Jinman, Unit 8, 6 Grasmere Court, Brentwood, WA	292.74	''	''
Linda Pullen, PO Box 259, Lutwyche, Qld	146.05	''	''
Luise Barnett, C/- CSFB Equities Australia, PO Box R1474, Royal Exchange, Sydney, NSW	390.53	''	''
Luke Ian Carter Wilton, PO Box 75, Gingin, WA	194.95	''	''
Lynette Marie Leunig, 21 Kanimbla Road, Nedlands, WA	234.32	''	''
M/s Sharon Noelle Clough, 35 Hefron Circle, Kalgoorlie, WA	146.05	''	''
Malcolm Dickie, PO Box 748, Nedlands, WA	439.42	''	''
Malcolm John Bush, 10 Radio Avenue, Balgowlah Heights, NSW	146.05	''	''

Marcel Dimoski, Unit 3, 2 Fintonia Road, Noble Park	175.90	''	''
Marcus Adam Cosgrave & Louis Salvagio, C/- 4/324 Edgecliff Road, Woollara, NSW	292.74	''	''
Mark Christopher Bennett, 69 Purseus Street, Silversands, WA	234.32	''	''
Mark Knebel, 3/86 Elovera Road, Cronulla, NSW	292.74	''	''
Mark Lindsay Davis, 40 Crossing Road, Aberfoyle Park, SA	439.42	''	''
Mark Tait & Diane Tait, 30 Lawrence Road, Innaloo, WA	146.05	''	''
Mary Porter Russell, 2 Malindi Street, Willetton, WA	146.05	''	''
McCouaig & Co Pty Ltd, GPO Box 1345, Brisbane, Qld	194.95	''	''
Melissa Donna White, 10 Grevillea Street, Muswellbrook, NSW	146.05	''	''
Merrilyn Smith, 7 Cantray Avenue, Applecross, WA	205.11	''	''
Michael P. Temple, 20 Autumnwood Ct, The Woodlands, Texas 77380, USA	194.95	''	''
Neil Warwick Laidler, 25 Eastern Road, Turrumurra, NSW	146.05	''	''
Nicholas Anthony Talbot Ott, PO Box 69, Broadford	234.32	''	''
Owen Joseph Fitzgerald, 25 Deacon Street, Basin Pocket, Qld	366.40	''	''
Paticoa Nominees Pty Ltd, GPO Box W2024, Perth, WA	132.08	''	''
Paul Edward Burton, 2/35 Paspaley Place, Cullen Bay, Darwin, NT	292.74	''	''
Paul Leslie Penman & Evelyn Kay Boucher, C/- Dow Corning Aust Pty Ltd, 16-18 Hall Street, Hawthorn East	317.50	''	''
Paul Martin & Martine Martin, 1 Fordham Drive, Swanview, WA	439.42	''	''
Penelope Cheng Sim Lim, 36H Dunearn Road, Chancery Crt, Singapore	292.74	''	''
Peter Craig Bleakley, Box 4258, Kalgoorlie, WA	146.05	''	''
Peter David Nayda & Mrs Geraldine Nayda, PO Box 203, Leonora, WA	292.74	''	''
Peter Francis Bevis, 9 Hawke Street, Slade Point, Mackay, Qld	307.34	''	''
Peter Preece, PO Box 402, Atherton, Qld	116.84	''	''
Peter Whitfield, 10 Radio Avenue, Balgowlah Heights, NSW	146.05	''	''
Phillip W. Barker, 6 Fraser Street, Rockingham, WA	116.84	''	''
Pont Securities Nominees No. 2 Pty Limited, GPO Box 7011, Sydney, NSW	292.74	''	''
Pynour Pty Ltd, 31 Nile Street, Woolloongabba, Qld	116.84	''	''
Ramon John Bath, PO Box 259, Lutwyche, Qld	146.05	''	''
Ray Melling, 37 Pilgrim Way, Hamilton Hill, WA	439.42	''	''
Raymond Pelham Dewson, 66 George Street, Kalgoorlie, WA	292.74	''	''
Reginald Grant Andrews, "RG Andrews Family A/c", 35 Broad Street, Marden, SA	439.42	''	''
Reginald John Forrest, 97 School Lane, Healesville	381.00	''	''
Richard John Bradfield & Delores J. Bradfield, 12 Gowdie Avenue, North Rockhampton, Qld	146.05	''	''
Robert Aley, Unit 4, 20 Princess Road, Crawley, WA	146.05	''	''
Robert Burgiel, 12 Quandong Road, Kambalda, WA	351.79	''	''
Robert Ellis, 19 Carlotta Road, Double Bay, NSW	439.42	''	''
Roger Harold Newton, 250 Amanda Dixon Park, Esperance, WA	234.32	''	''

---

Roger Hugh Dewhurst, Kaska Road, Hamurana, Rotorua, New Zealand	116.84	”	”
Ronald John McDonald, CMB 61, Deeral, Qld	146.05	”	”
Ruth Harland, 15 Coolum View Terrace Buderim, Qld	336.55	”	”
Sasha Giles-Peters, PO Box 45, Carlton North	292.74	”	”
Shane Wittmann, RMB 5840, Fingerboard Road, Yambuk	292.74	”	”
Stephen Andrew Seeto, Level 20, 56 Pitt Street, Sydney, NSW	439.42	”	”
Stephen Bret Jardine, 11 Tullamore Close, Waterford, WA	439.42	”	”
Stephen Yu, 3 Kooenba Road, Beverley Hills, NSW	194.95	”	”
Terrance John McFadyen, 16/150–152 Chuter Avenue, Ramsgate, NSW	205.11	”	”
Terry Frederick Taylor, 8B Markham Avenue, Runaway Bay, Qld	439.42	”	”
Timothy Hugh Seymour, Ridge House, Breach Lane, Shaftsbry, Dorset SP7 8LD, United Kingdom	292.74	”	”
Toni Holmes, 21 Blaxland Way, Padbury, WA	439.42	”	”
Vicki Sharon Neilsen, 357 Beckett Road, Bridgeman Downs, Qld	175.90	”	”
Wendy Wauchope, W & D Interior Design, 204 Grenfell Street, Adelaide, SA	292.74	”	”
William Henderson & Barbara Henderson, PO Box 38, Clare, SA	205.11	”	”

04025

CONTACT: LISA DOUMBOUYA, PHONE: (08) 9481 1277.

**PROCLAMATIONS**

**Port Services (Port Management  
Reform) Act 2003**

PROCLAMATION OF COMMENCEMENT

I, John Landy, Governor of Victoria, with the advice of the Executive Council and under section 2(2) of the **Port Services (Port Management Reform) Act 2003**, fix 1 April 2004 as the day on which sections 10, 24, 26(2), 30, 31, 32, 33, 34(2) and 35 of that Act come into operation.

Given under my hand and the seal of  
Victoria on the 30th March 2004.

(L.S.) JOHN LANDY  
Governor  
By His Excellency's Command

BOB CAMERON  
Acting Minister for Transport

---

**GOVERNMENT AND OUTER BUDGET  
SECTOR AGENCIES NOTICES**

MAROONDAH CITY COUNCIL

Road Discontinuance

At its meeting on 1 July 2002 and acting under Clause 3 of Schedule 10 to the **Local Government Act 1989** Maroondah City Council (Council) resolved to discontinue the road shown as Lots 1 and 2 on the plan below.

The land marked Lot 1 is to be sold subject to any right, power or interest held by Multinet Gas as to the land marked E-2 & E-4 and TXU Networks Pty Ltd as to the land marked E-3 & E-4, in the road in connection with any sewers, drains, pipes, cables or wires under the control of those authorities in or near the road.

The land marked Lot 2 is to be retained by Council for municipal purposes subject to any right, power or interest held by Yarra Valley Water Ltd as to the land marked E-1 in the road in connection with any sewers, drains or pipes under the control of this authority in or near the road.

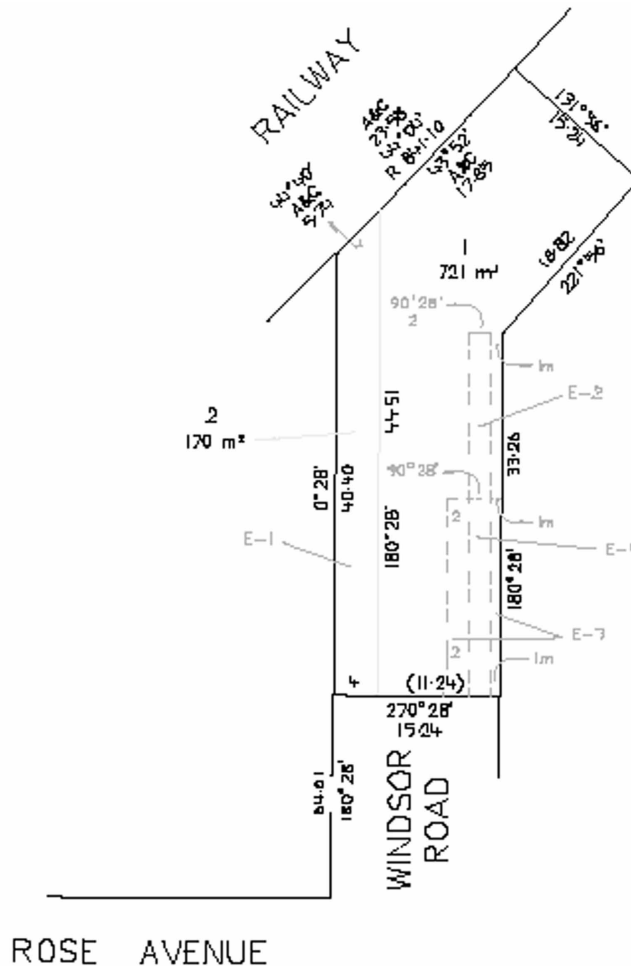

MICHAEL MARASCO  
Chief Executive

NORTHERN GRAMPIANS  
SHIRE COUNCIL

## Road Discontinuance

Pursuant to Section 206 and Schedule 10, Clause 3 of the **Local Government Act 1989**, the Northern Grampians Shire Council at its ordinary meeting held on 4 March 2004 formed the opinion that the unnamed roads shown hatched on the plan below and being parts of Government Road Reserves in the Parish of Moyreisk are not reasonably required as roads for public use and has resolved to discontinue the roads to allow implementation of LCC Recommendation 169 for Bushland Reserve.

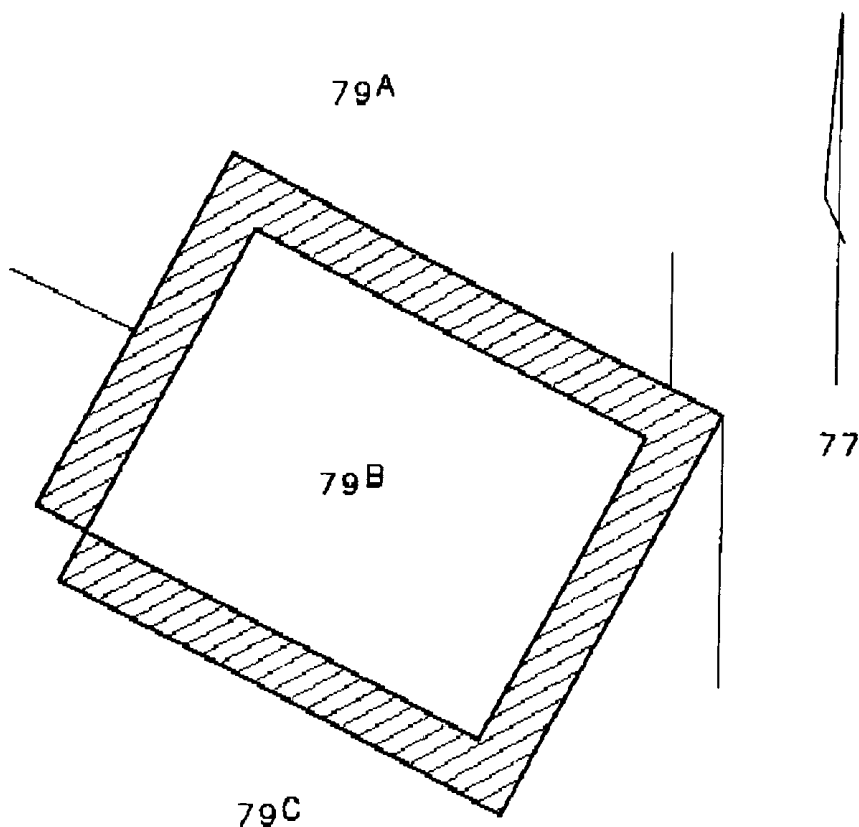

PETER BROOKS  
Chief Executive Officer

NORTHERN GRAMPIANS  
SHIRE COUNCIL

## Road Discontinuance

Pursuant to Section 206 and Schedule 10, Clause 3 of the **Local Government Act 1989**, the Northern Grampians Shire Council at its ordinary meeting held on 4 March 2004 formed the opinion that the unnamed road shown hatched on the plan below and being part of Government Road Reserve in the Parish of Riachella is not reasonably required as a road for public use and has resolved to discontinue the road to allow implementation of LCC Recommendation 13 for Bushland Reserve.



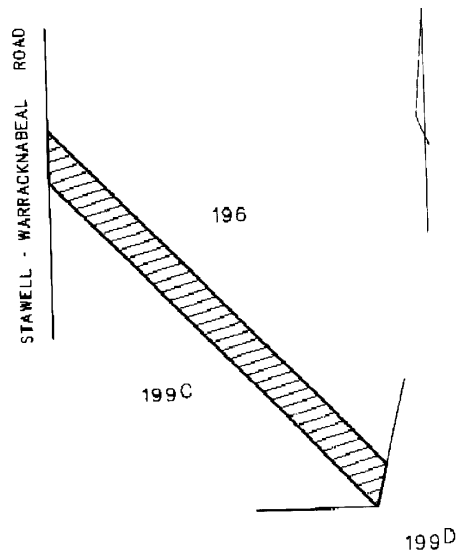

PETER BROOKS  
Chief Executive Officer

CARDINIA SHIRE COUNCIL

Road Discontinuance

At its meeting on 15 December 2003 and acting under Clause 3 of Schedule 10 to the **Local Government Act Vic. 1989**, Cardinia Shire Council:

1. formed the opinion that the unused portion of road abutting Lot 14 (No. 11) and Lot 15 (No. 7) Embrey Court and being land shown as Lot 1 on the plan below ("the road"), is not reasonably required as a road for public use; and
2. resolved to discontinue the road and when discontinued to retain or sell the land from the road.

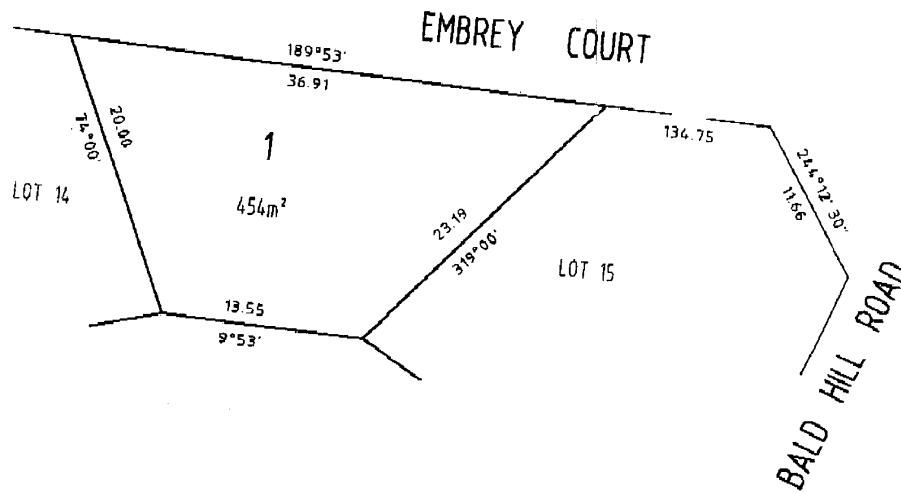

DON WELSH  
Chief Executive Officer



ROAD DISCONTINUANCE

Part of Taylor Street, Rupanyup

At its meeting held on 2 April 2002 Council acting under Section 206 and Schedule 10, Clause 3 of the **Local Government Act 1989**, Yarriambiack Shire resolved to discontinue part of the road as shown attached, as it is not reasonably required as a road for public use, and that the road be sold by private treaty subject to any right, power or interests held by Yarriambiack Shire Council in the road in connection with any sewers, drains or pipes under the control of the Shire in or near the road.

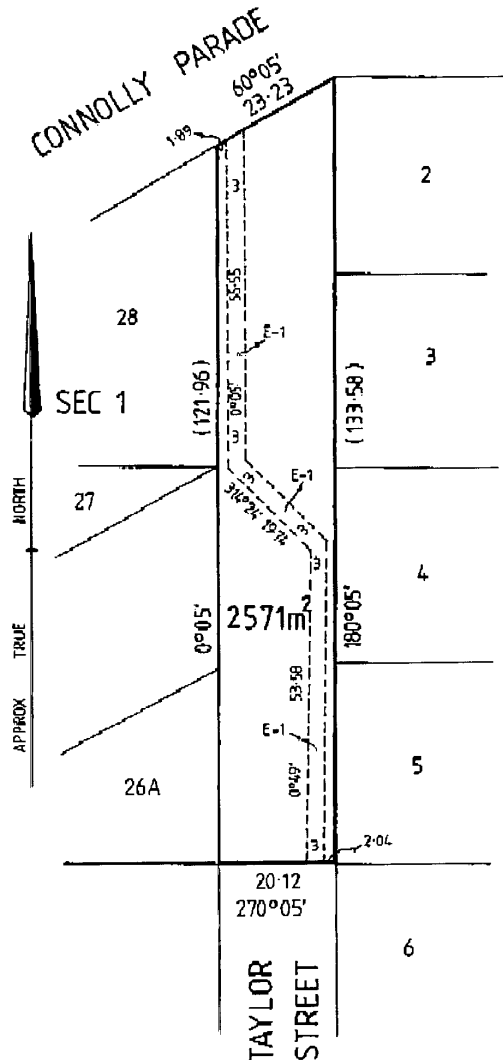

RAY CAMPLING  
Chief Executive Officer

## CITY OF WHITEHORSE

## Road Discontinuance

Under Section 206 and Schedule 10, Clause 3 of the **Local Government Act 1989** the Whitehorse City Council at its meeting held on Monday 15 December 2003 formed the opinion that the part of the road shown as Lot 1 on the plan below is not reasonably required as a road for public use and resolved to discontinue the road, and to sell the land from the road to the abutting owner, subject to any right, power or interest held by Whitehorse City Council in the road in connection with any drains or pipes under the control of that authority in or near the road, pursuant to Section 207C of the Act.

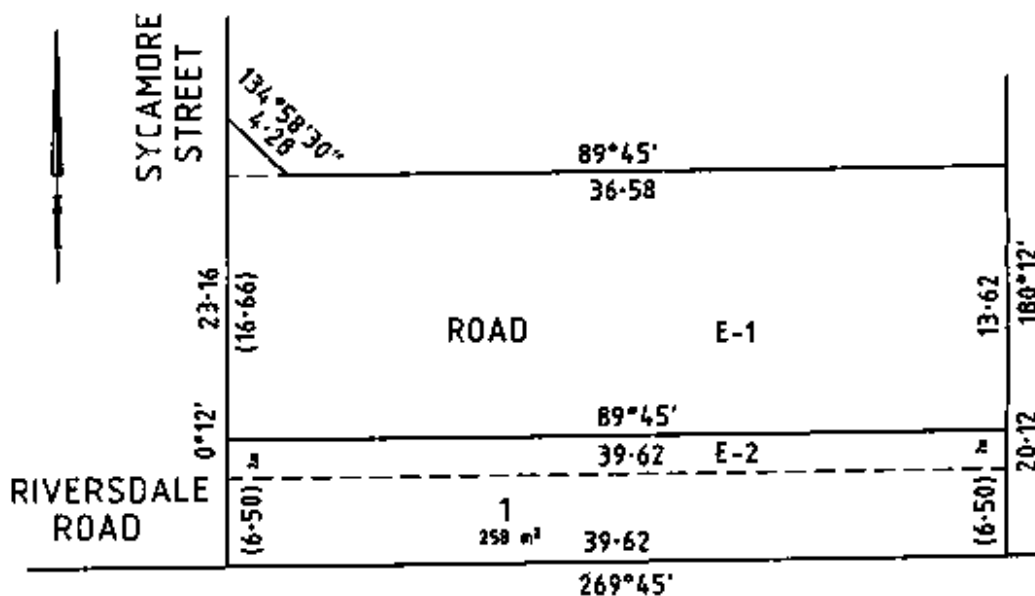

NOELENE DUFF  
Chief Executive Officer

## CITY OF MARIBYRNONG

## Roads Municipal Property and Council Land

## Local Law Number 2

Notice is given pursuant to Section 224A of the **Local Government Act 1989**, the City of Maribyrnong at its Ordinary Council meeting held on 23 February 2004 formed the opinion that the provision of Roads Municipal Property and Council Land Local Law Number 2, Clauses 39 & 40, stating:

“Unless in accordance with a permit, in a specified area, a person must not: consume alcohol; or be in possession or control of a container of alcohol unless it has not been opened; or allow another person to do so in, or on Council premises or a public area (in or on a stationary or moving vehicle situated in or on that place) except premises which are:

- licensed for that purpose under the **Liquor Control Act 1987**; or
- in an area which the consumption of alcohol is authorised in accordance with a permit under the **Liquor Control Act 1987**”

shall be extended to the following area: Walker Oval, Hansen Reserve, located on Roberts Street, West Footscray (Melway Ref: 41, G5).

This provision is to apply only between the hours of 8.00am and 5.00pm on days when official home games involving the North Footscray Football Club are occurring, from 1 April 2004 to 30 September 2004.

Notice also be given pursuant to Section 224A of the **Local Government Act 1989** that any member of the Victoria Police may enforce this provision in these specified areas.

KERRY THOMPSON  
Chief Executive Officer

#### BAYSIDE CITY COUNCIL

##### Notice of Adoption of New Meeting Procedures

##### Local Law No. 1

Notice is hereby given that Bayside City Council at its meeting held on 15 March 2004 resolved to adopt its new Meeting Procedures Local Law No. 1 entitled Meeting Procedures which repeals the existing Local Law No. 1 Meeting Procedures in its entirety and replace it with this Local Law No. 1 titled Meetings Procedures 2004.

The purpose of the Local Law is:

- a) provide a mechanism to facilitate the good government of the Municipal District of the City of Bayside through its formal meeting procedure to ensure effective and efficient Council decisions;
- b) provide mechanisms for the Council to ascertain the community's views and expectations;
- c) provide for the election of Mayor and Chairman of any Committees;
- d) regulate and control the procedures governing the conduct of meetings including:
  1. the notice required for meetings; and
  2. the keeping of minutes.
- e) regulate and control the use of Council's Seal;
- f) provide for the administration of the Council's powers and functions;
- g) provide generally for the peace, order and good government of the Municipal District.

The general purport of the Meeting Procedures Local Law will be to:

- revoke the existing Local Law No: 1 — Meeting Procedures made in August 2001 in its entirety;
- establish a law which will govern order of business, rules of debate, meeting procedure, public access and conduct of meetings;

- regulate the use and control of Council's common seal, and create an offence for a person using the common seal without authority or using a replica of the common seal without authority;
- regulate the procedure for the election of the Mayor;
- regulate the procedure of Public Question Time at Ordinary Meetings of Council;
- regulate the time limit of people making a submission to Council;
- regulate the availability of agenda papers to members of the public prior to meetings;
- regulate the procedure for amending a Notice of Motion;
- regulate the procedure for petitioners speaking to petitions;
- regulate the hearing of submissions at Committee Meetings of Council only;
- allow Council to suspend Standing Orders for a maximum period of 30 minutes;
- regulate the procedure to ensure that no discussion prior to a motion being moved;
- regulate the procedure for Points of Order.

This Local Law will come into effect from the date of gazettal.

Copies of the new Local Law are available from the Corporate Centre, 76 Royal Avenue, Sandringham.

IAN WILSON  
Chief Executive

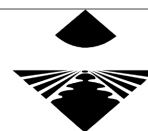

Mildura Rural City Council

#### NOTICE OF INTENTION TO MAKE A LOCAL LAW

##### Protection of Council Assets and Control of Building Sites — Local Law No. 5

Following Mildura Rural City Council's resolution at its meeting on 28 August 2003 and subsequent consultation with the community, a final draft of Local Law No. 5 has been prepared. Accordingly, Council now give notice pursuant to Section 119(2) of the **Local Government Act 1989** (the Act) and invite public submission in accordance with Section

223 of the Act regarding its intention to make a Local Law No. 5 — Protection of Council Assets and Control of Building Sites.

The purpose of the proposed Local Law is to:—

- protect public assets from damage;
- minimise hazards to health and safety;
- control the disposal of refuse, rubbish and soil on and from building sites;
- educate persons involved in building work.

Persons wishing to comment on the proposal may, pursuant to Section 223 of the Act, lodge formal written submission within 14 days of the publication of this notice to Chief Executive Officer, Mildura Rural City Council, PO Box 105, Mildura 3502.

Any person who has made a written submission to Council may request within that submission, that he or she be heard in person in support of the written submission or by a person acting on his or her behalf before a meeting of Council or a Council Committee.

Copies of the proposed Local Law are available from Mildura Rural City Council Administrative Officers in Madden Avenue, Mildura and Oke Street, Ouyen.

PHIL PEARCE  
Chief Executive Officer

#### **Planning and Environment Act 1987**

##### **GREATER BENDIGO PLANNING SCHEME**

###### **Notice of Amendment**

###### **Amendment C58**

The Minister for Planning has prepared Amendment C58 to the Greater Bendigo Planning Scheme.

The Amendment rezones land on the corner of High and Thistle Streets, Bendigo from Business 4 Zone and Public Park and Recreation Zone to Public Use Zone 7 — Other Public Use, and amends Schedule 1 to the Environment Significance Overlay to allow construction of the new Bendigo Police Station without a planning permit.

A copy of the Amendment can be inspected, free of charge, during office hours, at the Department of Sustainability and Environment, North West Regional Office, corner of Midland

Highway and Taylor Street, Epsom; at the Department of Sustainability and Environment Planning Information Centre, Upper Plaza, Nauru House, 80 Collins Street, Melbourne; and at the offices of the Greater Bendigo City Council, Hopetoun Mill, 15 Hopetoun Street, Bendigo.

Submissions about the Amendment must be sent to Minister for Planning, Attention: Prue Mansfield, Manager Planning and Development, North West Region, Department of Sustainability and Environment, Box 3100, Bendigo Delivery Centre 3554, by Monday 3 May 2004.

PAUL JEROME  
Deputy Secretary  
Built Environment  
Department of Sustainability  
and Environment

#### **Planning and Environment Act 1987**

##### **MARIBYRNONG PLANNING SCHEME**

###### **Notice of Preparation of Amendment**

###### **Amendment C41**

The Maribyrnong City Council has prepared Amendment C41 to the Maribyrnong Planning Scheme.

The land affected by the Amendment is 17–25 Hampstead Road, Maidstone (Certificate of Title Volume 9641, Folio 817).

The Amendment proposes to facilitate an integrated housing development with a mixed use component by:

- rezoning the land from an Industrial 3 Zone to part Residential 1 Zone and part Mixed Use Zone;
- applying a Development Plan Overlay (DPO8) over the land; and,
- applying an Environmental Audit Overlay over the land.

You may inspect the Amendment, any documents that support the Amendment and the explanatory report about the Amendment at the following locations: the office of the planning authority, Maribyrnong City Council, Reception Area, Municipal Offices, corner of Napier Street and Hyde Street, Footscray; the Highpoint Library, 200 Rosamond Road, Maribyrnong; the Footscray Library, 56 Paisley Street, Footscray; and the Department of Sustainability and

Environment, Planning Information Centre, Upper Plaza, Nauru House, 80 Collins Street, Melbourne.

This can be done during office hours and is free of charge.

Any person who may be affected by the Amendment may make a submission to the planning authority.

The closing date for submissions is 6 May 2004. A submission must be sent to: Mr David Walmsley, Manager Urban Planning, Maribyrnong City Council, PO Box 58, Footscray 3011.

KERRY THOMPSON  
Chief Executive Officer

### Planning and Environment Act 1987

#### WODONGA PLANNING SCHEME

#### Notice of Amendment to a Planning Scheme Amendment C35

The Wodonga Rural City Council has prepared Amendment C35 to the Wodonga Planning Scheme. The Amendment affects land, located along Elgin Boulevard, Wodonga, extending east of Watson Street through to High Street.

The Amendment proposes map and ordinance changes to the Wodonga Planning Scheme, to introduce a Design and Development Overlay and Development Plan Overlay over all of the land affected by the Amendment. The proposed Overlay controls will require development fronting Elgin Boulevard to comply with urban design guidelines aimed at revitalising the streetscape and ensuring the street remains the focus of retail activity. The controls affect the siting and design of buildings, car parking areas and advertising signs.

The Amendment can be inspected at: The City of Wodonga Offices, Hovell Street, Wodonga; Regional Office, Department of Sustainability and Environment, 35 Sydney Road, Benalla; and Department of Sustainability and Environment, Planning Information Centre, Nauru House, 80 Collins Street, Melbourne.

Submissions in writing in respect of the Amendment must be sent to the City of Wodonga, PO Box 923, Wodonga, Vic. 3689 by Friday 3 May 2004.

DARREN RUDD  
Manager Strategic Planning

Creditors, next-of-kin and others having claims against the estate of any of the undermentioned deceased persons are required to send particulars of their claims to State Trustees Limited, ABN 68 064 593 148, 168 Exhibition Street, Melbourne, Victoria 3000, the personal representative, on or before 2 June 2004 after which date State Trustees Limited may convey or distribute the assets having regard only to the claims of which State Trustees Limited then has notice.

BULLEN, Rosemary, late of Warrenvale Special Accommodation Home, 314 Reynolds Road, Donvale, pensioner and who died on 28 February 2004.

HALE, Doreen Mary, late of 8 Studley Road, Brighton East, Victoria 3187, retired, and who died on 12 March 2004.

HAMMOND, Harry James, late of Unit 14, 15 McCracken Avenue, Northcote, Victoria 3070, retired and who died on 27 January 2004.

KRISTIC, Charlotte, late of Martin Luther Home, 67 Mount View Road, The Basin, Victoria 3154, retired and who died on 29 January 2004.

McAUSLAN, Elsie Clara, late of Oakmoor Nursing Home, 352 Warrigal Road, Oakleigh South, pensioner, and who died on 21 January 2004.

SFYRIS, Varvara, also known as Barbara Sfiris, late of St Basils Home for the Aged, 24-36 Lorne Street, Fawkner, pensioner and who died on 19 January 2004.

TANNER, Harold Geoffrey, late of 23 Dry Creek Crescent, Wandong, retired and who died on 25 February 2004.

Dated 24 March 2004

LAURIE TAYLOR  
Estate Manager  
State Trustees Limited

#### STATE TRUSTEES LIMITED ACN 064 593 148 Section 79

Notice is hereby given that State Trustees Limited, ACN 064 593 148 intends administering the estate of:-

JACQUELINE MAY McEWAN, late of 86 Milton Street, Elwood, Victoria, retired, deceased intestate, who died on 13 August 2001.

Creditors, next-of-kin and others having claims against the abovementioned estate are required pursuant to Section 33 of the **Trustee Act 1958** to send particulars of their claims against the abovementioned estates to State Trustees Limited, 168 Exhibition Street, Melbourne, Victoria, on or before 4 June 2004 after which date State Trustees Limited, ACN 064 593 148, may convey or distribute the assets of the abovementioned estate having regard only to the claims of which it then has notice.

Creditors, next-of-kin and others having claims against the estate of any of the undermentioned deceased persons are required to send particulars of their claims to State Trustees Limited, ABN 68 064 593 148, 168 Exhibition Street, Melbourne, Victoria 3000, the personal representative, on or before 4 June 2004 after which date State Trustees Limited may convey or distribute the assets having regard only to the claims of which State Trustees Limited then has notice.

FILIMONOVIC, Martha, also known as Marta Filiminovic, late of 14 Grist Street, St Albans, pensioner and who died on 1 November 2003.

HENRY, Irene Isobel, formerly of 4/382 Deakin Avenue, Mildura, but late of Sunraysia Aged Care Facility, 253 Tenth Street, Mildura, pensioner and who died on 10 February 2004.

JOHNSON, Robert Morton, late of 1A Bolton Street, Beaumaris, Victoria 3193, retired and who died on 4 February 2004.

MAWHINNEY, Ernest John, late of 39 Cobden Street, Kew, retired bus driver and who died on 24 May 1985.

MAWHINNEY, Ruby Laurel, late of 11 Garibaldi Street, Healesville, pensioner and who died on 12 June 1996.

O'BRIEN, Eileen Patricia, late of Buckland House Nursing Home, 53 Highett Street, Mansfield, pensioner and who died on 16 January 2004.

QUINSEY, Albert Leslie, late of 45 Rubicon Street, Reservoir, Victoria 3073, and who died on 2 February 2004.

Dated 25 March 2004

LAURIE TAYLOR  
Estate Manager  
State Trustees Limited

#### EXEMPTION

Application No. A95/2004

The Victorian Civil & Administrative Tribunal (the Tribunal) has considered an application pursuant to Section 83 of the **Equal Opportunity Act 1995** (the Act) by the University of Melbourne (the applicant), for exemptions from Sections 13, 100 and 195 of the Act. The application for exemption is to enable the applicant to advertise for and employ a person of indigenous Australian background to the position of Director, Centre for Indigenous Education (CIE) located with the Academic Services Division.

Upon reading the material in support of the application, the Tribunal is satisfied that it is appropriate to grant an exemption from Sections 13, 100 and 195 of the Act to enable the applicant to advertise for and employ a person of indigenous Australian background to the position of Director, Centre for Indigenous Education.

The Tribunal noted that the grant of the exemption is consistent with the applicant's commitment to affirmative action to increase the number of staff of Aboriginal and Torres Strait Islander descent at the university until indigenous appointments comprise at least 1% of total staff, as outlined in the Indigenous Employment Strategy introduced by the applicant in 2003. Consistent with that commitment, it is noted that the number of indigenous staff employed at the University of Melbourne has risen from 16 in 2003 to 27 in 2003. The Tribunal also noted the importance of the position of Director, Centre for Indigenous Education, in developing and managing the recruitment and support services for Indigenous students at the university. The Tribunal is satisfied on the material that the request for an exemption under the Act is in the public interest and accords with the broad objectives of the Act which are to create equality of opportunity for disadvantaged groups in the fields of education and employment.

The Tribunal hereby grants an exemption to the applicant from the operation of Sections 13, 100 and 195 of the Act to enable the applicant to advertise for and recruit a person of indigenous Australian background to the position of Director, Centre for Indigenous Education.

This exemption is to remain in force from the day on which notice of the exemption is published in the Government Gazette until 31 March 2007.

Dated 24 March 2004.

Mrs S. DAVIS  
Deputy President

Janet Elizabeth Smith, who has resigned from the Adoption and Permanent Care Team, Department of Human Services.

JOHN LEATHERLAND  
Regional Director  
Eastern Metropolitan Region

#### Adoption Act 1984

##### APPOINTMENT OF COUNSELLORS FOR RELINQUISHMENT COUNSELLING

Under the functions and powers assigned to me by the Secretary, Department of Human Services Victoria under Section 10(2) of the **Community Services Act 1970** in relation to Section 5 of the **Adoption Act 1984**, I, John Leatherland, approve the following persons under Section 5(1) and Section 5(2)(A) of the **Adoption Act 1984** as approved counsellors for the purpose of Section 35 of the **Adoption Act 1984**.

Eastern Metropolitan Region

Blankenstein, Martine.

Ravesteyn, Ingrid.

JOHN LEATHERLAND  
Regional Director  
Eastern Metropolitan Region

#### Adoption Act 1984

Under the functions and powers assigned to me by the Secretary, Department of Human Services Victoria under Section 10(2) of the **Community Services Act 1970** in relation to Section 5 of the **Adoption Act 1984**, I, John Leatherland, revoke the following person under Section 5(1) and Section 5(2)(A) of the **Adoption Act 1984** as approved counsellor for the purposes of Section 35 and Section 87 of the **Adoption Act 1984**.

Black, Margaret Grace.

Dated 24 March 2004

JOHN LEATHERLAND  
Regional Director  
Eastern Metropolitan Region

#### Adoption Act 1984

I wish to withdraw the notice from Gazette No. G13 published on 6 April 1995. Specifically, in reference to gazetted worker,

#### Agricultural and Veterinary Chemicals (Control of Use) Act 1992

##### APPOINTMENT OF AUTHORISED OFFICERS

I, JOHN WILLIAM GALVIN, Manager Animal Health Operations in the Department of Primary Industries, pursuant to the powers, duties and functions given to me by a delegation under section 74 of the **Agricultural and Veterinary Chemicals (Control of Use) Act 1992** and of my respective powers to appoint authorised officers under section 53 of the **Agricultural and Veterinary Chemicals (Control of Use) Act 1992**, hereby appoint the following persons employed in the Public Service, as authorised officers for the purposes of all of the provisions of the **Agricultural and Veterinary Chemicals (Control of Use) Act 1992** and any Regulation or Order made under this Act.

Name of person	Position number
Stephanie Marija Andreata	507214
Andrew John Winterbottom	12659

Dated 18 March 2004

JOHN WILLIAM GALVIN  
Manager  
Animal Health Operations

#### Livestock Disease Control Act 1994

##### APPOINTMENT OF INSPECTORS

I, JOHN WILLIAM GALVIN, Manager Animal Health Operations in the Department of Primary Industries, pursuant to the powers, duties and functions given to me by a delegation under section 103 of the **Livestock Disease Control Act 1994** and of my respective powers to appoint inspectors under section 108 of the **Livestock Disease Control Act 1994**, hereby appoint the following persons, who hold positions under the provisions of the **Public Sector Management and Employment Act 1998**, as inspectors for the purposes of all of the



provisions of the **Livestock Disease Control Act 1994** and in respect of all livestock.

<b>Name of person</b>	<b>Position number</b>
Stephanie Marija Andreata	507214
Andrew John Winterbottom	12659

Dated 18 March 2004

JOHN WILLIAM GALVIN  
Manager  
Animal Health Operations

#### **Prevention of Cruelty to Animals Act 1986**

##### APPROVAL OF INSPECTORS

I, PETER JOHN BAILEY, Director Quality Assurance in the Department of Primary Industries, pursuant to the powers, duties and functions given to me by a delegation under section 38 of the **Prevention of Cruelty to Animals Act 1986** and of my respective powers to approve inspectors under section 18 of the **Prevention of Cruelty to Animals Act 1986**, hereby approve the following persons, who are inspectors of livestock under the provisions of the **Livestock Disease Control Act 1994**, as inspectors for the purposes of Part 2 of the **Prevention of Cruelty to Animals Act 1986**. These approvals remain in force until 30 June 2006.

<b>Name of person</b>	<b>Position number</b>
Stephanie Marija Andreata	507214
Andrew John Winterbottom	12659

Dated 18 March 2004

PETER JOHN BAILEY  
Director Quality Assurance

#### **Children's Services Act 1996**

##### NOTICE OF EXEMPTION

Under Section 6 of the **Children's Services Act 1996** ("the Act"), the Minister for Community Services hereby declares that Ouyen Preschool, Licence Number 3630 ("the service") is exempt from the qualified staff members requirement as set out in regulation 24 of the Children's Services Regulations 1998.

The exemption is granted subject to the conditions that the proprietor must ensure that:

- 1) whenever children are being cared for or educated by the service, the number of staff

members as set out in regulation 24 are caring and educating the children; and the staff members must include a staff member who holds a primary teaching qualification;

- 2) the staff member with the primary teacher qualification is currently enrolled and attending a course to attain an approved early childhood qualification; and
- 3) the staff member with the primary qualification receives mentoring from a person with an early childhood teaching qualification.

This exemption remains in force until 31 December 2004.

Declared at Melbourne 17 March 2004

HON SHERRYL GARBUTT MP  
Minister for Community Services

#### **Co-operatives Act 1996**

##### FISHWELL CO-OPERATIVE SOCIETY LIMITED

##### NORTH EAST RURAL EDUCATION PROJECT CO-OPERATIVE LIMITED

Notice is hereby given in pursuance of Section 316(1) of the **Co-operatives Act 1996** and Section 601AB(3)(e) of the **Corporations Act 2001** that, at the expiration of two months from the date hereof, the names of the aforementioned co-operatives will, unless cause is shown to the contrary, be struck off the register and the co-operatives will be dissolved.

Dated at Melbourne 26 March 2004

ANDREW LEVENS  
Deputy Registrar of Co-operatives

#### **Country Fire Authority Act 1958**

##### VARIATION OF FIRE DANGER PERIOD

In pursuance of the powers conferred by Section 4 of the **Country Fire Authority Act 1958**, I, Geoff Spring, Acting Chief Executive Officer of the Country Fire Authority, after consultation with the Secretary to the Department of Sustainability and Environment, hereby vary the declaration of the Fire Danger Periods previously published in the Government Gazette by declaring that such Fire Danger Periods shall end in respect of the undermentioned Municipal Districts of Municipalities or parts of Municipalities specified.

To terminate from 0100 hours 5 April 2004: Hindmarsh Shire Council (Remainder); Yarriambiack Shire Council (Remainder); Horsham Rural City Council (Northern Part) that part north of the line described by the following roads:— Bow Lake Fire Access Road, Bow Lake Road, Jallumba/Clear Lake Road, Jallumba/Mockinya Road, Wonwondah/Toolondo Road, North East Wonwondah Road, Grampians Road, Wonwondah/Dadswells Bridge Road, Fulbrooks Road to the Wimmera River; West Wimmera Shire Council (part): That part north of the line described by the following roads:— Elliot's Road, Northern Break, McDonald Highway; Baw Baw Shire Council; South Gippsland Shire Council.

G. SPRING  
Acting Chief Executive Officer

**Electricity Industry Act 2000**  
NOTIFICATION OF VARIATION  
TO LICENCE

The Essential Services Commission gives notice under section 30 of the **Electricity Industry Act 2000** that it has, pursuant to section 29(1)(b) of the Act, varied the electricity generation licence issued to AES Transpower Pty Ltd (ACN 086 589 611) by changing the name of the licensee from AES Transpower Pty Ltd (ACN 086 589 611) to Ecogen Energy Pty (ACN 086 589 611).

A copy of the licence is available on the Commission's website located at <http://www.esc.vic.gov.au> or a copy can be obtained by calling Mr Richard Bunting on (03) 9651 3657.

Dated 25 March 2004

JOHN C. TAMBLYN  
Chairperson

**Land Acquisition and Compensation Act 1986**  
FORM 7 S.21  
Reg. 16

Notice of Acquisition

Compulsory Acquisition of Interest in Land

The Roads Corporation (VicRoads) declares that by this notice it acquires the following interest in the land described as part of Lot 2 Plan of Subdivision 517635X, Parish of

Faraday, comprising 1.158 hectares and being land described in Certificate of Title Volume 10786, Folio 024, shown as Parcel 22 on Survey Plan 20661B.

**Interest Acquired:** That of Ronald James and Sarah Jane Krulow and all other interests.

Published with the authority of VicRoads.

Dated 1 April 2004

For and on behalf of VicRoads:  
BERNARD TOULET,  
Manager Property Services Department

**Land Acquisition and Compensation Act 1986**  
FORM 7 S.21  
Reg. 16

Notice of Acquisition

Compulsory Acquisition of Interest in Land

The Roads Corporation (VicRoads) declares that by this notice it acquires the following interest in the land described as part of Crown Allotment 1A, Section 2A, parish of Faraday, comprising 3.961 hectares and being land described in Certificate of Title Volume 4988, Folio 566, shown as Parcel 21 on Survey Plan 20661B.

**Interest Acquired:** That of Ronald James Krulow and all other interests.

Published with the authority of VicRoads.

Dated 1 April 2004

For and on behalf of VicRoads:  
BERNARD TOULET,  
Manager Property Services Department

**Land Acquisition and Compensation Act 1986**  
FORM 7 S.21  
Reg. 16

Notice of Acquisition

Compulsory Acquisition of Interest in Land

The Roads Corporation (VicRoads) declares that by this notice it acquires the following interest in the land described as the whole of Crown Allotments 20B and 20E, Section 5C, parish of Harcourt, comprising 9814 square metres and being land described in Certificate of Title Volume 9428, Folio 597, shown as Parcels 63 and 64 on Survey Plan MA20663.

**Interest Acquired:** That of David John Palmer and all other interests.

Published with the authority of VicRoads.

Dated 1 April 2004

For and on behalf of VicRoads:  
BERNARD TOULET,  
Manager Property Services Department

registration of JAMES PATRICK WALSH (date of birth 17 April 1960) effective from 17 February 2004.

Dated 23 March 2004

SUSAN HALLIDAY  
Chairperson of Panel  
Victorian Institute of Teaching

### Land Acquisition and Compensation Act 1986

FORM 7

S.21

Reg. 16

Notice of Acquisition

Compulsory Acquisition of Interest in Land

The Roads Corporation (VicRoads), declares that by this notice it acquires the following interest in the land described as part of Crown Allotment 6, Section 32, Parish of Ararat comprising 1724.0 square metres and being land described in Certificate of Title Volume 6622, Folio 387, shown as Parcels 10 and 11 on Survey Plan 20231.

**Interest Acquired:** That of Jamie Alan Stewart and all other interests.

Published with the authority of VicRoads.

Dated 1 April 2004

For and on behalf of VicRoads:  
BERNARD TOULET,  
Manager Property Services Department

### Victorian Managed Insurance Authority Act 1996

HEIDE MUSEUM OF MODERN ART

Pursuant to section 25A of the **Victorian Managed Insurance Authority Act 1996**, I direct the Victorian Managed Insurance Authority (VMIA) to provide insurance to Heide Museum of Modern Art (Heide). This insurance cover is to be effective from 1 July 2004, for a period of one year and should continue the existing policy terms.

JOHN LENDERS MP  
Minister for Finance

### Victorian Managed Insurance Authority Act 1996

HERITAGE AND TOURIST RAIL  
AND TRAM OPERATORS  
VICTORIAN TOURISM OPERATORS  
ASSOCIATION

Pursuant to Section 25A (1) (b) of the **Victorian Managed Insurance Authority Act 1996**, I hereby direct you to provide an indemnity to the following class of bodies:

1. Heritage and Tourist Rail and Tram Operators  
Cover for 12 months, on existing terms and conditions (other than the premium that VMIA will determine), for those operators currently covered under the existing scheme.
2. Victorian Tourism Operators Association (VTOA)  
Cover to 30 April 2004, on existing terms and conditions (other than the premium that VMIA will determine), for those operators currently covered under the existing scheme.

JOHN LENDERS MP  
Minister for Finance

### Victorian Institute of Teaching Act 2001

NOTIFICATION CANCELLING  
REGISTRATION OF A TEACHER

Pursuant to section 42 of the **Victorian Institute of Teaching Act 2001** (the Act) the Victorian Institute of Teaching (the Institute) may make a determination to cancel the registration of a teacher.

The panel of the Victorian Institute of Teaching (the Institute) appointed under section 38 of the **Victorian Institute of Teaching Act 2001** (the Act) has made a determination to cancel the registration of a teacher.

On 17 February 2004 the panel of the Institute made a decision to cancel the

**Water Act 1989**PORTLAND COAST REGION  
WATER AUTHORITY

I, Ross Davies, Director Water Resource Management, Department of Sustainability and Environment, as the delegate of the Minister for Water, make the following Order:

EXTENSION OF THE PORTLAND WATER  
DISTRICT ORDER 2004

1. This Order is called the Extension of the Portland Water District Order 2004.
2. This Order is made under sections 96 and 104 of the **Water Act 1989** and all other available powers.
3. This Order takes effect from the date it is published in the Government Gazette.
4. The proposal for an extension of the Portland Water District, submitted to the Department of Sustainability and Environment on 3 February 2004, is approved.
5. The Extension to the Portland Water District is the area of land within the broken red border on the accompanying plan No. 118, a copy of which may be inspected at the office of the Portland Coast Region Water Authority, situated at 15 Townsend Street, Portland, Victoria 3305.

Dated 16 March 2004

ROSS DAVIES  
Director, Water Resource Management  
Department of Sustainability  
and Environment  
(as delegate of the Minister for Water)

**Water Act 1989**

## SECTION 96

## Coliban Region Water Authority

## Declaration of Newstead Sewerage District

In accordance with the requirements of Section 96(7)(c) of the **Water Act 1989** notice is given of a proposed Newstead Sewerage District. This district, located in the Parishes of Strangways, Sandon and Tarrengower, and is bounded by the northern boundary of the Parish of Strangways in the north; the western boundary of the Cemetery Reserve and Cusacks Road in the east; Pound Lane in the south; and the western boundary of the Parish of Sandon and Clarke Road in the west.

A plan of the proposed district can be viewed free of charge at Coliban Water, 37–45 Bridge Street, Bendigo; at the Castlemaine Town Hall, 25 Lyttleton Street, Castlemaine, and also at the Enterprise Centre, Halford Street, Castlemaine, during office hours.

Submissions are invited from members of the public. Any person making a submission should set out the grounds for any objection raised in the submission.

Submissions should be sent to Cheryl Fitzgerald, Corporate Secretary, Coliban Region Water Authority, Box 2770, Bendigo Delivery Centre, 3554 and must be received by the Authority within one month after publication of this notice in the Government Gazette.

Submissions must be received by 1 May 2004.

**Private Agents Act 1966**NOTICE OF RECEIPT OF APPLICATION  
FOR COMMERCIAL AGENT'S  
SUB-AGENT'S LICENCE UNDER THE  
PROVISIONS OF THE  
**PRIVATE AGENTS ACT 1966**

I, the undersigned, being the Registrar of the Magistrates' Court at Dandenong hereby give notice that application, as under, has been lodged for hearing by the said Court on the date specified.

Any person desiring to object to any of such application must—

- (a) lodge with me a notice in the prescribed form of his objection and of the grounds thereof;
- (b) cause a copy of such notice to be served personally or by post upon the applicant at least three days before the hearing of the application; and
- (c) send or deliver
  - (i) where the objection is not made by the officer in charge of the police district in which the Court is situated—a copy of the notice to such officer; and
  - (ii) where the objection is not made by the Registrar or Deputy Registrar—a copy to the Registrar.

<i>Full Name of Applicant or in the case of a Firm or Corporation, of the Nominee</i>	<i>Place of Abode of Applicant or Nominee</i>	<i>Name of Firm or Corporation</i>	<i>Address for Registration</i>	<i>Type of Licence</i>	<i>Date of Hearing of Application</i>
James Kenneth Best	19 Carrington Place, Berwick, Victoria 3806			Commercial Agent's Licence	03/05/04

Dated at Dandenong 25 March 2004

KEITH TURNER  
Registrar of the  
Magistrates' Court of Victoria

### Private Agents Act 1966

#### NOTICE OF RECEIPT OF APPLICATIONS FOR LICENCES UNDER THE PROVISIONS OF THE PRIVATE AGENTS ACT 1966

I, the undersigned, being the Clerk of the Magistrates' Court at Frankston, hereby give notice that application, as under, have been lodged for hearing by the said Court on the date specified.

Any person desiring to object to any of such application must—

- (a) lodge with me a notice in the prescribed form of his objection and of the grounds thereof;
- (b) cause a copy of such notice to be served personally or by post upon the applicant at least three days before the hearing of the application; and
- (c) send or deliver
  - (i) where the objection is not made by the officer in charge of the police district in which the Court is situated—a copy of the notice to such officer; and
  - (ii) where the objection is not made by the Registrar or Deputy Registrar—a copy to the Registrar.

<i>Full Name of Applicant or in the case of a Firm or Corporation, of the Nominee</i>	<i>Place of Abode of Applicant or Nominee</i>	<i>Name of Firm or Corporation</i>	<i>Address for Registration</i>	<i>Type of Licence</i>	<i>Date of Hearing of Application</i>
Peter Anthony Prassinis	5 Ceduna Close, Wantirna		422 Warrigal Road, Moorabbin	Commercial Agent	27/04/04
Jennifer Butterworth	30 Davies Drive, Mount Eliza		422 Warrigal Road, Moorabbin	Commercial Sub-Agent	27/04/04
Leilarni Thompson	9 Tracey Street, Doncaster East		422 Warrigal Road, Moorabbin	Commercial Sub-Agent	27/04/04

Dated at Frankston 29 March 2004

STUART POPE  
Senior Registrar of the  
Frankston Magistrates' Court

**Trustee Companies Act 1984**  
**State Trustees (State Owned Company) Act 1994**  
 SCHEDULE OF FEES, COMMISSIONS & DISBURSEMENTS  
 Inclusive of GST — effective 15 January 2004

**State Trustees Limited**

<b>1. Deceased Estate, Powers of Attorney, Agencies, Court-appointed Administrations, Other Administrations and Personal Trusts</b>	
<b>Capital Commission</b>	
Once only capital commission on the gross value of any assets of estates where administration commenced after the date of this schedule	Not to exceed 5.5%
<b>Common Funds Investments Management Fee</b>	
Management fee on the capital sum invested in any of State Trustees' Common Funds	1.1% per annum
<b>Income Commission</b>	
On gross income received	Not to exceed 6.6%
On Centrelink or Department of Veterans Affairs pensions	3.3%
Where the administration of an estate commenced before the commencement of the GST on 1 July 2000, the relevant capital and income commission shall, subject to any agreement or other restriction to the contrary, be at the rate of the published schedule at the time the administration commenced, plus 10%.	
<b>2. Victorian Civil and Administrative Tribunal — Guardianship List appointed administrations</b>	
<b>Capital Commission</b>	
From 1 January 2002, a once-only capital commission on the gross Value of any assets of the estate	Not to exceed 4.4%
<b>Common Funds Investments Management Fee</b>	
Management fee on the capital sum invested in any of State Trustees' Common Funds	1.1% per annum
<b>Income Commission</b>	
On gross income received	Not to exceed 6.6%
On Centrelink or Department of Veterans Affairs pensions	3.3%
Where the administration of an estate commenced before the commencement of the GST on 1 July 2000, the relevant capital and income commission shall, subject to any agreement or other restriction to the contrary, be at the rate of the published schedule at the time the administration commenced, plus 10%.	
<b>3. Legal Services</b>	
<b>Probate Fees</b>	Charged in accordance with current Supreme Court rules
<b>Conveyancing Fees</b>	Not to exceed current Practitioner Remuneration Order 1998 charges

<b>Provision of legal advice</b>	
Senior Solicitor	\$198 per hour
Solicitor	\$137.50 per hour
<b>Litigation fees</b>	Charged in accordance with relevant Court scale
<b>4. Taxation Services</b>	
<b>Advice, returns, manual reviews and assessments</b>	\$127.60 per hour
<b>Computer assisted reviews</b>	\$63.80 per review
<b>5. State Trustees Funeral Fund</b>	
Please refer to the State Trustees Funeral Fund Disclosure Document for fees and commissions related to this product.	
<b>6. Victorian Civil and Administrative Tribunal - Guardianship List</b>	
<b>Temporary Order Administration</b>	\$132 per hour
<b>Private Administrations</b>	\$132 per hour
Examinations, review and preparation of accounts and advice on Victorian Civil and Administrative Tribunal — Guardianship List, Private Administrations.	
<b>7. Executor Advice</b>	
Advice relating to deceased estate administrations where State Trustees is not appointed Executor or Administrator	\$132 per hour
<b>8. Informal Administration</b>	
Cases where no formal grant is obtained or commission taken	\$132 per hour
<b>9. Genealogical Services</b>	
	\$132 per hour
<b>10. Discretionary Testamentary Trusts</b>	
	Negotiable with client
<b>11. Will Preparation</b>	
Commonwealth Benefits Card holders	\$44 per person
Seniors Card holders	\$100 per person
All other persons	\$125 per person
Joint or reciprocal Wills for two persons	\$195 per couple
Complex Will	Negotiable with client
<b>12. Will Alteration</b>	
Commonwealth Benefits Card holders	\$27.50 per person
Seniors Card holders	\$40 per person
All other persons	\$50 per person
Joint or reciprocal Wills for two persons	\$75 per couple

<b>13. Australia Foundation and Private Charitable Trusts</b>		
<b>Management Fee on funds held in a Common Fund</b>		1.1% p.a.
Plus either:		
(a) Administration Fee		Up to 1.056% p.a.
or:		
(b) Income Commission; and Capital Commission		6.6% p.a. Up to 5.5%
<b>14. Commercial Trusts</b>		
		Negotiable with client
<b>15. Custodial Services, Unit Registry and Asset Management Services</b>		
		Negotiable with client*
*From 1 January 2001 State Trustees is the custodian of the Premium Funds (refer to the Premium Funds section in this Schedule).		
<b>16. Business Administration Services</b>		
Contractual management of specified activities and related projects		Negotiable with client
<b>17. Financial Planning</b>		
<b>Preparation of Statement of Advice:</b>		\$550 (only if not implemented)
If plan is implemented:		
<b>Entry Fees</b>		
Based on the value of investments, individual entry fees are disclosed in the Statement of Advice. Actual entry fees will depend on investments selected and the overall value of the portfolio.		
<b>Trail Commissions</b>		
Based on the average value of investments, individual trail commissions are disclosed in the Statement of Advice. Actual trail commissions will depend on the investments selected.		
<b>Review Fee</b>		
\$330 minimum where there are no changes to the Statement of Advice (review recommended annually, effected only upon prior agreement with client).		
Note: Further fees may apply if portfolio is adjusted.		
<b>18. Financial Planning for Powers of Attorney, Agencies, Court-appointed Administrations, Statutory Administrations, Other Administrations, Personal Trusts and Deceased Estates</b>		
<b>Value of Portfolio</b>	<b>Plan Fee</b>	<b>Review Fee</b>
Less than \$100,000	\$440	\$275
\$100,001 – \$300,000	\$825	\$550



\$300,001 – \$400,000	\$1,100	\$770
\$400,001 – \$500,000	\$1,650	\$880
\$500,001 – \$750,000	\$2,200	\$1,320
\$750,001 – \$1,000,000	\$3,300	\$1,980
Over \$1,000,000	Not to exceed \$5,500	Not to exceed \$3,300
<p>*Fees are based on the complexity of the clients portfolio and personal situation, and are not to exceed the percentages shown.</p> <p>All investment entry fees received by State Trustees are rebated to the client.</p> <p>External Fund Managers may pay to State Trustees a trail commission of generally no more than 0.4% depending upon the investments selected. Where this occurs, the specific percentage will be detailed in the Statement of Advice.</p>		
<b>19. Travel (Victoria only)</b>		
<b>Travel involved in providing any service may be subject to an additional charge</b>		
To a site within a 40 kilometre radius of the Melbourne GPO		\$66 per visit
To a site beyond a 40 kilometre radius of the Melbourne GPO		\$110 per visit
<b>20. Advances</b>		
Where funds are advanced from State Trustees' General Account, interest will be charged at a rate not exceeding the rate fixed from time to time under Section 2 of the <b>Penalty Interest Rates Act 1983</b> , less 2.5%.		
<b>21. Disbursements</b>		
Disbursements may be charged to the client including the cost of GST where applicable.		
<b>22. Reduction of Waiver</b>		
The fees, commission and charges set out in this Schedule may be reduced or waived by State Trustees at its discretion.		
<b>23. Interpretation</b>		
All hourly charges taken on a pro rata basis. State Trustees has the discretion to negotiate an hourly fee for the provision of any of its services.		
<b>24. Goods &amp; Services Tax (GST)</b>		
All fees and commissions of State Trustees in this Schedule are inclusive of any GST payable. GST is not payable in respect of advances.		
If a service is provided under an existing agreement and the service is GST-free, the agreed charges for the service will remain unaffected by GST-related tax reform until the agreement is able to be reviewed by the parties, or until legislation or other regulatory change permits the adjustment of the charges.		

## STL Financial Services Limited

<b>Premium Funds</b>	<b>Application Fee@</b>	<b>Management Fee (Paid monthly)</b>	<b>Custodian Fee (Paid monthly)</b>	<b>Switching Fee*</b>
<b>Premium Cash Fund</b>	0% of your investment	0.6%p.a. of capital value of Fund		1% of switch value
<b>Premium Cash Plus Fund^</b>	0.75% of your investment	0.6%p.a. of capital value of Fund		1% of switch value
<b>Premium Fixed Interest Fund</b>	0.75%p.a. of your investment	0.8%p.a. of capital value of fund	FOR ALL FUNDS: A maximum of 0.03%p.a. of capital value of Fund	1% of switch value
<b>Premium Property Fund</b>	1.5% of your investment	1.0%p.a. of capital value of Fund		1% of switch value
<b>Premium Equity Fund</b>	1.5% of your investment	1.0%p.a. of capital value of Fund		1% of switch value
<b>Premium International Fund</b>	1.5% of your investment	1.0%p.a. of capital value of Fund		1% of switch value
<b>Premium Diversified Fund#</b>	1.5% of your investment	1.0%p.a. of capital value of Fund		1% of switch value

@ Not applicable to Regular Savings Plan contributions or reinvestment of distributions.

\* No charge for first 3 switches, 1% of switch value thereafter. Please refer to the Premium Funds Product Disclosure Statement for further information related to this product.

^ The Premium Cash Plus Fund was previously known as the Premium Mortgage Fund.

# The Premium Diversified Fund was previously known as the Premium Managed Fund.

Applications for investment can only be made on the application form attached to the current Premium Funds Product Disclosure Statement issued by STL Financial Services Limited, which has been lodged with the Australian Securities and Investments Commission.

A copy of the Product Disclosure Statement may be obtained by calling State Trustees on 9667 6444.

**Goods & Services Tax (GST)**

All fees and commissions of State Trustees in this schedule are inclusive of any GST payable. If a service is provided under an existing agreement and the service is GST-free, the agreed charges for the service will remain unaffected by GST-related tax reform until the agreement is able to be reviewed by the parties, or until legislation or other regulatory change permits the adjustment of the charges.

**Planning and Environment Act 1987****BALLARAT PLANNING SCHEME**

## Notice of Approval of Amendment

## Amendment C66

The Minister for Planning has approved Amendment C66 to the Ballarat Planning Scheme.

The Amendment comes into operation on the date this notice is published in the Government Gazette.

The Amendment affects various parcels of land within the City of Ballarat. The Amendment:

- removes privately owned land from a public zone;
- extends the boundary of a public zone to include adjoining public land;
- removes public land from a public zone and includes it within the same zoning as surrounding land where that zone is more appropriate.

A copy of the Amendment can be inspected, free of charge, during office hours, at the Department of Sustainability and Environment, Planning Information Centre, Upper Plaza, Nauru House, 80 Collins Street, Melbourne and at the offices of the Ballarat City Council, Phoenix Office, 25 Armstrong Street South, Ballarat.

PAUL JEROME  
Deputy Secretary  
Built Environment  
Department of Sustainability  
and Environment

**Planning and Environment Act 1987****BASS COAST PLANNING SCHEME**

## Notice of Approval of Amendment

## Amendment C30 Part 2

The Minister for Planning has approved Amendment C30 Part 2 to the Bass Coast Planning Scheme.

The Amendment comes into operation on the date this notice is published in the Government Gazette.

The Amendment alters the Schedule to the Rural Zone at Clause 35.01 allowing land comprising Lot 1 on PS 422683, Churchill

Road, Cape Woolamai to be subdivided to create a separate title for land accommodating the Vietnam Veterans Museum.

A copy of the Amendment can be inspected, free of charge, during office hours, at the Department of Sustainability and Environment, Planning Information Centre, Upper Plaza, Nauru House, 80 Collins Street, Melbourne; and at the offices of the Bass Coast Shire Council, Customer Service Centre, 76 McBride Avenue, Wonthaggi; Customer Service Centre, 91–97 Thompson Avenue, Cowes; Customer Service Centre, 3 Reilly Street, Inverloch; and Customer Service Centre, Shop 3, Bass Highway, Grantville.

PAUL JEROME  
Deputy Secretary  
Built Environment  
Department of Sustainability  
and Environment

**Planning and Environment Act 1987****CASEY PLANNING SCHEME**

## Notice of Approval of Amendment

## Amendment C56

The Minister for Planning has approved Amendment C56 to the Casey Planning Scheme.

The Amendment comes into operation on the date this notice is published in the Government Gazette.

The Amendment applies Public Acquisition Overlay 3 — Municipal purposes to part of the land at 230 Hallam Road, Hampton Park, being part Lot A on PS 428489C, to provide for the public acquisition of land required for the future upgrade of the Hallam Road/Ormond Road intersection.

A copy of the Amendment can be inspected, free of charge, during office hours, at the Department of Sustainability and Environment, Planning Information Centre, Upper Plaza, Nauru House, 80 Collins Street, Melbourne and at the offices of the Casey City Council, Magid Drive, Narre Warren.

PAUL JEROME  
Deputy Secretary  
Built Environment  
Department of Sustainability  
and Environment

**Planning and Environment Act 1987**GREATER DANDENONG  
PLANNING SCHEME

## Notice of Approval of Amendment

## Amendment C31 Part 1

The Minister for Planning has approved Amendment C31 Part 1 to the Greater Dandenong Planning Scheme.

The Amendment comes into operation on the date this notice is published in the Government Gazette.

## The Amendment:

- applies permanent heritage controls to various places identified in Council's heritage study, deletes interim heritage controls applying to 5 heritage places, and updates the heritage and cultural elements in the Greater Dandenong Planning Scheme's Municipal Strategic Statement (MSS);
- modifies and permanently includes 3 Incorporated Documents into the Scheme;
- includes 2 additional Incorporated Documents applying to the International Harvester Factory and Heinz Factory into the Scheme;
- includes the Incorporated Document *Bunurong Memorial Park Concept Plan (Oct 1993)* into the Scheme, after its accidental omission with the introduction of the new format Greater Dandenong Planning Scheme in 1999.

A copy of the Amendment can be inspected, free of charge, during office hours, at the Department of Sustainability and Environment, Planning Information Centre, Upper Plaza, Nauru House, 80 Collins Street, Melbourne and at the offices of the Greater Dandenong City Council, Dandenong Office, 39 Clow Street, Dandenong.

PAUL JEROME  
Deputy Secretary  
Built Environment  
Department of Sustainability  
and Environment

**Planning and Environment Act 1987**

## KNOX PLANNING SCHEME

## Notice of Approval of Amendment

## Amendment C21

The Minister for Planning has approved Amendment C21 to the Knox Planning Scheme.

The Amendment comes into operation on the date this notice is published in the Government Gazette.

## The Amendment:

- applies a Special Building Overlay (SBO) and Land Subject to Inundation Overlay (LSIO) to land throughout the municipality identified as being subject to overland flows;
- updates Clauses 21.07 and 21.08 of the Municipal Strategic Statement (MSS) to reflect the use of the SBO and LSIO as means for achieving the objectives of these Clauses, and makes consequential changes to Clauses 61.01–61.04;
- alters the planning scheme map and schedule to the Heritage Overlay to include the Templer Church Hall, 3 Wadi Street, Boronia and ensures consistency with the Victorian Heritage Register, and makes corrections to Clauses 21.04 and 21.10 of the MSS.

A copy of the Amendment can be inspected, free of charge, during office hours, at the Department of Sustainability and Environment, Planning Information Centre, Upper Plaza, Nauru House, 80 Collins Street, Melbourne and at the offices of the Knox City Council, 511 Burwood Highway, Wantirna South.

PAUL JEROME  
Deputy Secretary  
Built Environment  
Department of Sustainability  
and Environment

**Planning and Environment Act 1987**

## MANNINGHAM PLANNING SCHEME

## Notice of Approval of Amendment

## Amendment C32

The Minister for Planning has approved Amendment C32 to the Manningham Planning Scheme.

The Amendment comes into operation on the date this notice is published in the Government Gazette.

The Amendment introduces permanent heritage protection to three identified heritage places:

HO203 — 'Menlo', 17–25 Atkinson Street, Templestowe;

HO204 — 103 James Street, Templestowe; and  
 HO206 — ‘Cornwall House’, 103 Old  
 Warrandyte Road, Donvale; and  
 Deletes HO202 — ‘Orwell Park’, 15 Atkinson  
 Street, Templestowe.

A copy of the Amendment can be inspected,  
 free of charge, during office hours, at the  
 Department of Sustainability and Environment,  
 Planning Information Centre, Upper Plaza,  
 Nauru House, 80 Collins Street, Melbourne and  
 at the offices of the Manningham City Council,  
 Civic Offices, 699 Doncaster Road, Doncaster.

PAUL JEROME  
 Deputy Secretary  
 Built Environment  
 Department of Sustainability  
 and Environment

#### **Planning and Environment Act 1987**

##### **MOORABOOL PLANNING SCHEME**

###### Notice of Approval of Amendment

###### Amendment C3 Part 1

The Minister for Planning has approved  
 Amendment C3 Part 1 to the Moorabool  
 Planning Scheme.

The Amendment comes into operation on the  
 date this notice is published in the Government  
 Gazette.

The Amendment:

- corrects mapping and ordinance anomalies  
 and errors;
- makes additions to the Environmental  
 Significance Overlay Schedule 1 (Proclaimed  
 Water Catchment Areas) and the Design and  
 Development Overlay Schedule 2 (Visual  
 Amenities and Building Design); and
- introduces a new Schedule 3 to the Design  
 and Development Overlay (National Route 8  
 (Western Freeway/ Highway) Environs).

A copy of the Amendment can be inspected,  
 free of charge, during office hours at the  
 Department of Sustainability and Environment,  
 Planning Information Centre, Upper Plaza,  
 Nauru House, 80 Collins Street, Melbourne and  
 at the Moorabool Shire Council municipal  
 offices, 197 Main Street, Bacchus Marsh.

PAUL JEROME  
 Deputy Secretary  
 Built Environment  
 Department of Sustainability  
 and Environment

#### **Planning and Environment Act 1987**

##### **MOYNE PLANNING SCHEME**

###### Notice of Approval of Amendment

###### Amendment C12

The Minister for Planning has approved  
 Amendment C12 to the Moyne Planning  
 Scheme.

The Amendment comes into operation on the  
 date this notice is published in the Government  
 Gazette.

The Amendment:

- applies the Heritage Overlay to the  
 Bessiebelle Sheepwashes and Yards and the  
 Former Customs Shed site, and includes  
 them in the Schedule to the Heritage  
 Overlay;
- corrects the listing of the Former Bank of  
 Australasia and the Yambuk Inn in the  
 Schedule to the Heritage Overlay;
- corrects the mapping of the following  
 Victorian Heritage Register sites:
  - Merrang Homestead, 1830 Woolsthorpe  
 Hexham Road, Hexham
  - Tower Hill Common School, High Street,  
 Koroit
  - Mortlake Mill and Chimney, Mill Street,  
 Mortlake
  - former Merrijig Inn, 1–3 Campbell Street,  
 Port Fairy
  - Court House, 30 Gipps Street, Port Fairy
  - former Lifeboat Station, Griffith Street,  
 Port Fairy
  - Motts Cottage, 5 Sackville Street, Port  
 Fairy
  - former St Andrew’s Presbyterian Church  
 and Manse, 33 William Street, Port Fairy
  - Yambuk Inn, Princes Hwy, Yambuk
  - former Macarthur Court House, corner  
 High and Heckford Street, Macarthur.

A copy of the Amendment can be inspected,  
 free of charge, during office hours at the  
 Department of Sustainability and Environment,  
 Planning Information Centre, Upper Plaza,  
 Nauru House, 80 Collins Street, Melbourne and  
 at the Moyne Shire Council Municipal Offices,  
 Princes Street, Port Fairy.

PAUL JEROME  
 Deputy Secretary  
 Built Environment  
 Department of Sustainability  
 and Environment

**Planning and Environment Act 1987**

WHITTLESEA PLANNING SCHEME

Notice of Approval of Amendment

Amendment C55

The Minister for Planning has approved Amendment C55 to the Whittlesea Planning Scheme.

The Amendment comes into operation on the date this notice is published in the Government Gazette.

The Amendment rezones part of the land at 23-31 Plenty Road, Bundoora from Residential 1 Zone to Business 1 Zone.

The Minister has granted the following permits under Division 5 Part 4 of the Act:

Permit No.: Whittlesea Planning Scheme  
Permit No. 707987.

Description of land: Part of 23-31 Plenty Road, Bundoora (11 Nickson Street)

A copy of the Amendment and permit/s can be inspected, free of charge, during office hours, at the Department of Sustainability and Environment, Planning Information Centre, Upper Plaza, Nauru House, 80 Collins Street, Melbourne and at the offices of the Whittlesea City Council, Ferris Boulevard, South Morang.

PAUL JEROME  
Deputy Secretary  
Built Environment  
Department of Sustainability  
and Environment

---

## ORDERS IN COUNCIL

### Taxation (Reciprocal Powers) Act 1987 DECLARATION OF CORRESPONDING LAWS AND CORRESPONDING OFFICES UNDER SECTION 3(2)

#### Order in Council

The Governor in Council, acting under section 3(2) of the **Taxation (Reciprocal Powers) Act 1987** ("the Act"), declares that —

- (a) a law specified in column 2 of the Table opposite a State Taxation Act specified in column 1 of the Table is a corresponding law for the purposes of the Act in relation to that State Taxation Act; and
- (b) an office specified in column 3 of the Table under a law specified in column 2 of the Table is a corresponding office for the purposes of the Act in relation to the office of the State Commissioner under the State Taxation Act specified in column 1 of the Table opposite that office.

*TABLE*

Column 1 Victorian Taxation Act	Column 2 Corresponding Laws	Column 3 Corresponding Offices
Duties Act 2000	Stamp Amendment Act 2003 (WA)	Commissioner of State Revenue
	Stamp Act 1921 (WA)	Commissioner of State Revenue
Taxation Administration Act 1997	Debits Tax Act 2002 (WA)	Commissioner of State Revenue
	Debits Tax Assessment Act 2002 (WA)	Commissioner of State Revenue
	Land Tax Act 2002 (WA)	Commissioner of State Revenue
	Land Tax Assessment Act 2002 (WA)	Commissioner of State Revenue
	Pay-roll Tax Act 2002 (WA)	Commissioner of State Revenue
	Pay-roll Tax Assessment Act 2002 (WA)	Commissioner of State Revenue
	Taxation Administration Act 2003 (WA)	Commissioner of State Revenue
	Taxation Administration (Consequential Provisions) Act 2002 (WA)	Commissioner of State Revenue
	Taxation Administration (Consequential Provisions) (Taxing) Act 2002 (WA)	Commissioner of State Revenue
Land Tax Act 1958	Land Tax Act 2002 (WA)	Commissioner of State Revenue
	Land Tax Assessment Act 2002 (WA)	Commissioner of State Revenue
Debits Tax Act 1990	Debits Tax Act 2002 (WA)	Commissioner of State Revenue
	Debits Tax Assessment Act 2002 (WA)	Commissioner of State Revenue
Pay-roll Tax Act 1971	Pay-roll Tax Act 2002 (WA)	Commissioner of State Revenue
	Pay-roll Tax Assessment Act 2002 (WA)	Commissioner of State Revenue

<b>Column 1 Victorian Taxation Act</b>	<b>Column 2 Corresponding Laws</b>	<b>Column 3 Corresponding Offices</b>
Taxation (Reciprocal Powers) Act 1987	Taxation Administration Act 2003 (WA)	Commissioner of State Revenue

Dated 23 March 2004

Responsible Minister  
JOHN BRUMBY MP  
Treasurer

DIANE CASEY  
Clerk of the Executive Council

### **Parliamentary Committees Act 2003**

#### LAW REFORM COMMITTEE OF PARLIAMENT

#### Inquiry into Warrant Powers and Procedures Extension of Reporting Date

#### Order in Council

The Governor in Council, under section 33 of the **Parliamentary Committees Act 2003** amends the reporting date referred to in the Order in Council dated 3 June 2003 requiring the Law Reform Committee of Parliament to inquire into warrant powers and procedures by substituting the date by which the Committee must report to the Parliament on the inquiry from 31 March 2004, to the last day of the Autumn 2005 sittings of Parliament.

The Order is to be effective from the date of gazettal.

Dated 30 March 2004

Responsible Minister  
STEVE BRACKS  
Premier

DIANE CASEY  
Clerk of the Executive Council

### **Children and Young Persons Act 1989**

#### ABOLISH AND ESTABLISH YOUTH SUPERVISION UNITS

#### Order in Council

The Governor in Council under Section 249(d) of the **Children and Young Persons Act 1989** and on the recommendation of the Minister, declares that, with effect from date of publication in the Government Gazette:

1. The Bayside (Westernport) Youth Welfare Service at 68 Bardia Avenue, Seaford previously established as a youth welfare service by Order in Council on 4 November 1987 and published in the Government Gazette on 11 November 1987 is abolished; and
2. Establishes youth supervision units on the Ground Floor, 431 Nepean Highway, Frankston and at 131–147 Walker Street, Dandenong.

Dated 30 March 2004

Responsible Minister  
HON SHERRYL GARBUTT MP  
Minister for Community Services

DIANE CASEY  
Clerk of the Executive Council



**Electricity Industry Act 2000**TEMPORARY ELECTRICITY LICENCE  
EXEMPTION — YAMASA AUSTRALIA

## Order in Council

The Governor in Council acting under Section 17 of the **Electricity Industry Act 2000** (the “Act”) makes the following Order:

*Yamasa Australia Pty Ltd (ACN 77 052 859 971)* (“Yamasa”) is exempt from the requirement to obtain a licence for the sale of electricity to *Sakata Rice Snacks Australia Pty Ltd (ACN 94 064 157 026)* (“Sakata”).

This exemption is subject to the following conditions:

- a) Yamasa must take no action which prevents Sakata from purchasing electricity from any retailer of its choice;
- b) Yamasa must take no action which prevents any retailer from selling electricity to Sakata;
- c) Yamasa must provide (whether or not through an agent), to the Minister or the Essential Services Commission, any information either entity may reasonably require for the administration of this Order; and
- d) Yamasa must resolve any issues of concern raised by the Essential Services Commission, to the Essential Services Commission’s satisfaction.

This Order commences on the day on which it is published in the Government Gazette and continues in effect for one year, unless sooner revoked.

Dated 30 March 2004

Responsible Minister  
THEO THEOPHANOUS  
Minister for Energy Industries

DIANE CASEY  
Clerk of the Executive Council

**Crown Land (Reserves) Act 1978**NOTICE OF INTENTION TO REVOKE  
TEMPORARY RESERVATIONS

The Governor in Council under section 10 of the **Crown Land (Reserves) Act 1978** gives notice of intention to revoke the following temporary reservations:—

CLUNES — The temporary reservation by Order in Council of 10 April 1951 of an area of 3035 square metres, more or less, of land in the Parish of Clunes as a site for a Rubbish Depot. — (Rs 6652).

TERRINALLUM — The temporary reservation by Order in Council of 1 December 1953 of an area of 5.539 hectares of land in the Parish of Terrinallum as a site for Public Recreation. — (Rs 7139).

WALHALLA — Crown Allotments 123A and 123C, Parish of Walhalla (formerly Township of Walhalla) transferred to the Crown by transfer No. J979343 registered at the Office of Titles on 23 June 1982 and deemed to be temporarily reserved for the purpose of conservation of an area of natural and historic interest under Section 5(7) of the **Crown Land (Reserves) Act 1978**. — (Rs 12980).

WAREEK — The temporary reservation by Order in Council of 22 December 1902 of an area of 8094 square metres of land in the Township of Wareek, Parish of Wareek (formerly being part Crown Allotment 9, Section 6C) as a site for a State School. — (Rs 1167).

WAREEK — The temporary reservation by Order in Council of 13 October 1903 of an area of 5372 square metres of land in the Township of Wareek, Parish of Wareek (formerly being part Crown Allotment 9, Section 6C) as a site for a State School, in addition to and adjoining the site temporarily reserved therefor by Order in Council of 22 December 1902, revoked as to part by Orders in Council of 15 June 1915 and 27 April 1983 so far as the balance remaining containing 2453 square metres, more or less. — (Rs 1167).

This Order is effective from the date on which it is published in the Government Gazette.

Dated 30 March 2004

Responsible Minister  
MARY DELAHUNTY  
Minister for Planning

DIANE CASEY  
Clerk of the Executive Council

**Crown Land (Reserves) Act 1978**  
**TEMPORARY RESERVATION OF**  
**CROWN LANDS**

The Governor in Council under section 4(1) of the **Crown Land (Reserves) Act 1978** temporarily reserves the following Crown lands which in his opinion are required for the purposes mentioned:—

**MUNICIPAL DISTRICT OF THE**  
**GREATER BENDIGO CITY COUNCIL**

**EAGLEHAWK** — Reservoir and Public Park, 1.70 hectares, more or less, being Crown Allotments 2012, 2013, 2014 and 2015, at Eaglehawk, Parish of Sandhurst as indicated by hatching on plan hereunder. (GP1411) — (06P126388).

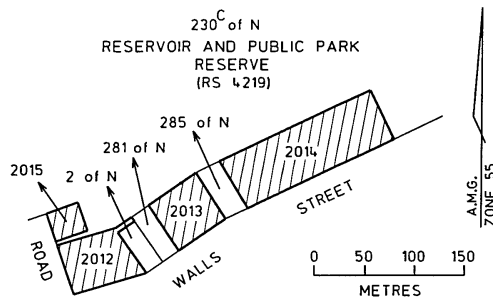

TOTAL AREA OF HATCHED PORTIONS IS 1.70ha ±

**MUNICIPAL DISTRICT OF THE**  
**MOORABOOL SHIRE COUNCIL**

**LAL LAL** — Conservation of an area of historic interest, 260.7 hectares, being Crown Allotment 16E, Section 12A, Parish of Lal Lal as indicated by hatching on plan hereunder. (GP832) — (05880902).

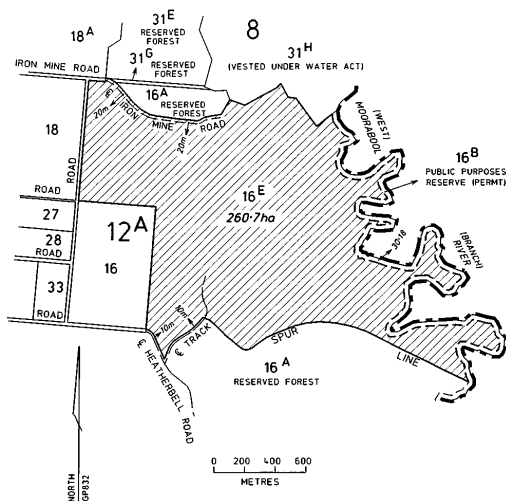

**MUNICIPAL DISTRICT OF THE**  
**WELLINGTON SHIRE COUNCIL**

**YARRAM YARRAM** — Public purposes (Municipal purposes), 830 square metres being Crown Allotment 50A, Parish of Yarram Yarram as indicated by hatching on plan hereunder. (GP1466) — (2013312).

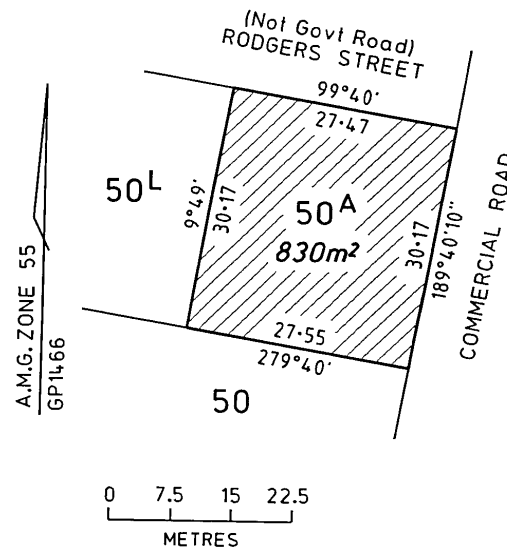

This Order is effective from the date on which it is published in the Government Gazette.

Dated 30 March 2004

Responsible Minister  
**MARY DELAHUNTY**  
 Minister for Planning

**DIANE CASEY**  
 Clerk of the Executive Council

**Land Act 1958**

**CLOSURE OF UNUSED ROAD**

The Governor in Council under section 349 of the **Land Act 1958** and with the concurrence in writing of the municipality in which the road is situated closes the following unused road:

**MUNICIPAL DISTRICT OF THE**  
**HEPBURN SHIRE COUNCIL**

**CLUNES** — The road in the Parish of Clunes being Crown Allotment 2001 as indicated by hatching on plan hereunder. (GP1243) — (0615597).

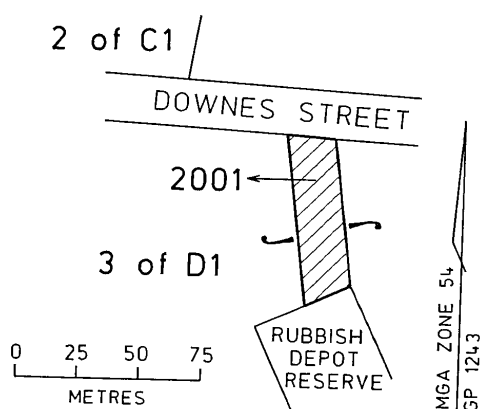

This Order is effective from the date on which it is published in the Government Gazette.

Dated 30 March 2004

Responsible Minister  
MARY DELAHUNTY  
Minister for Planning

DIANE CASEY  
Clerk of the Executive Council

**Land Act 1958**

**CLOSURE OF UNUSED ROAD**

The Governor in Council under section 349 of the **Land Act 1958** and with the concurrence in writing of the municipality in which the road is situated and the owners of land adjoining the road closes the following unused road:

**MUNICIPAL DISTRICT OF THE  
BASS COAST SHIRE COUNCIL**

**WONTHAGGI NORTH** — The road in the Parish of Wonthaggi North being Crown Allotment 2001 as indicated by hatching on plan hereunder. (GP1446) — (2003591).

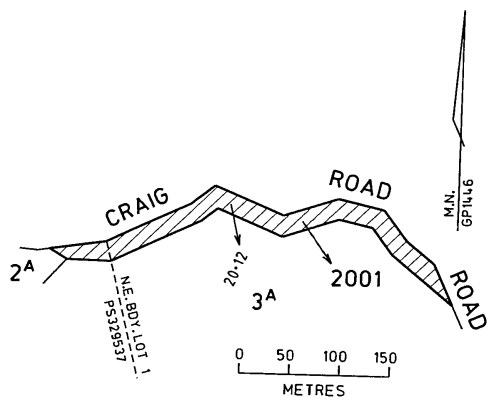

This Order is effective from the date on which it is published in the Government Gazette.

Dated 30 March 2004

Responsible Minister  
MARY DELAHUNTY  
Minister for Planning

DIANE CASEY  
Clerk of the Executive Council

**Racing Act 1958**

**GUARANTEE OF BOOKMAKERS  
AGAINST DEFAULTS IN PAYMENT  
OF WAGERS**

**Order in Council**

The Governor in Council under section 94A(2B) of the **Racing Act 1958**, and on the recommendation of the Minister for Racing amends:

the Order in Council dated 24 September 2002 by deleting the following words in Table 2

“future win/place” means—

- (i) a bet made by the nomination of a horse or greyhound on the chance that such horse or greyhound will fill first place or fill first, second or third place in a specified race providing that the race is decided at a race meeting conducted on a day after the day the bet is placed; or
- (ii) a bet made by the nomination of a horse or greyhound on the chance that such horse or greyhound will fill first place in three specified races;
- (iii) but does not include a bet made when a bookmaker is operating under a club betting permit issued by the Minister.

and inserting the following words in Table 2

“future win/place” means—

- (i) a bet made with a Bookmaker who is authorised by Racing Victoria Limited, Harness Racing Victoria or Greyhound Racing Victoria (as the case may be) to accept future win/place bets; and is
- (ii) a bet made by the nomination of a horse or greyhound on the chance that such horse or greyhound will fill first

place or fill first, second or third place in a specified race providing that the bet is made no later than 30 minutes prior to the advertised start time of the race on which the bet is decided; or

- (iii) a bet made by the nomination of a horse or greyhound on the chance that such horse or greyhound will fill first place in three specified races;
- (iv) but does not include a bet made when a bookmaker is operating under a club betting permit issued by the Minister.

This Order is effective from the day in which it appears in the Government Gazette.

Dated 30 March 2004

Responsible Minister  
JOHN PANDAZOPOULOS MP  
Minister for Racing

DIANE CASEY  
Clerk of the Executive Council

### **Victorian Plantations Corporation Act 1993**

#### VESTED LANDS TO REVERT TO THE CROWN

The Governor in Council under section 17(2) of the **Victorian Plantations Corporation Act 1993** divests the lands described in the schedule hereunder and reverts the subject lands in the Crown:

#### SCHEDULE

Crown Allotment 99M2 No Section Parish of Howqua West being 12.03 ha as shown on Plan OP117472-A lodged in the Central Plan Office.

Crown Allotment 99L2 No Section Parish of Howqua West being 3.378 ha as shown on Plan OP117472-A lodged in the Central Plan Office.

Crown Allotment 101H No Section Parish of Howqua West being 10.57 ha as shown on Plan OP117472-A lodged in the Central Plan Office.

Crown Allotment 108M14 No Section Parish of Howqua West being 49.68 ha as shown on Plan OP117472-A lodged in the Central Plan Office.

Crown Allotment 2006 No Section Parish of Howqua West being 0.026 ha as shown on Plan LEGL./03-016 lodged in the Central Plan Office.

Crown Allotment 2005 No Section Parish of Howqua West being 0.092 ha as shown on Plan LEGL./03-016 lodged in the Central Plan Office.

Crown Allotment 2004 No Section Parish of Howqua West being 0.082 ha as shown on Plan LEGL./03-016 lodged in the Central Plan Office.

Crown Allotment 108M6 No Section Parish of Howqua West being 79.12 ha as shown on Plan OP117472-A lodged in the Central Plan Office.

Crown Allotment 108M7 No Section Parish of Howqua West being 121.2 ha as shown on Plan OP117472-A lodged in the Central Plan Office.

Crown Allotment 108M9 No Section Parish of Howqua West being 0.7226 ha as shown on Plan OP117472-A lodged in the Central Plan Office.

Crown Allotment 108M10 No Section Parish of Howqua West being 52.1 ha as shown on Plan OP117472-A lodged in the Central Plan Office.

Crown Allotment 108M12 No Section Parish of Howqua West being 23.43 ha as shown on Plan OP117472-A lodged in the Central Plan Office.

Crown Allotment 2014 No Section Parish of Howqua West being 2.095 ha as shown on Plan LEGL./03-017 lodged in the Central Plan Office.

Crown Allotment 2002 No Section Parish of Howqua West being 0.099 ha as shown on Plan LEGL./03-016 lodged in the Central Plan Office.

Crown Allotment 2003 No Section Parish of Howqua West being 0.362 ha as shown on Plan LEGL./03-016 lodged in the Central Plan Office.

Crown Allotment 108M3 No Section Parish of Howqua West being 0.3937 ha as shown on Plan OP117472-A lodged in the Central Plan Office.

Crown Allotment 2001 No Section Parish of Howqua West being 0.572 ha as shown on Plan LEGL./03-016 lodged in the Central Plan Office.

Crown Allotment 108R No Section Parish of Howqua West being 8.919 ha as shown on Plan OP117472-A lodged in the Central Plan Office.

Crown Allotment 108M1 No Section Parish of Howqua West being 72.43 ha as shown on Plan OP117472-A lodged in the Central Plan Office.

Crown Allotment 108S No Section Parish of Howqua West being 193.1 ha as shown on Plan OP117472-A lodged in the Central Plan Office.

Crown Allotment 2015 No Section Parish of Howqua West being 22.2 ha as shown on Plan LEGL./03-017 lodged in the Central Plan Office.

Crown Allotment 2012 No Section Parish of Howqua West being 0.083 ha as shown on Plan LEGL./03-017 lodged in the Central Plan Office.

Crown Allotment 2016 No Section Parish of Howqua West being 0.044 ha as shown on Plan LEGL./03-017 lodged in the Central Plan Office.

Crown Allotment 2013 No Section Parish of Howqua West being 0.1185 ha as shown on Plan LEGL./03-017 lodged in the Central Plan Office.

Crown Allotment 99L3 No Section Parish of Howqua West being 0.158 ha as shown on Plan LEGL./03-017 lodged in the Central Plan Office.

This Order is effective from the date on which it is published in the Government Gazette.

Dated 30 March 2004

Responsible Minister  
JOHN THWAITES  
Minister for Environment

DIANE CASEY  
Clerk of the Executive Council

---

**SUBORDINATE LEGISLATION ACT 1994  
NOTICE OF MAKING OF STATUTORY  
RULES**

Notice is hereby given under Section 17 (2) of the **Subordinate Legislation Act 1994** of the making of the following Statutory Rules:

24. *Statutory Rule:* Electricity Safety (Equipment Efficiency) (Amendment) Regulations 2004  
*Authorising Act:* Electricity Safety Act 1998  
*Date of making:* 30 March 2004
25. *Statutory Rule:* Tobacco (Victorian Health Promotion Foundation) (Membership) Regulations 2004  
*Authorising Act:* Tobacco Act 1987  
*Date of making:* 30 March 2004

**SUBORDINATE LEGISLATION ACT 1994  
NOTICE THAT STATUTORY RULES ARE  
OBTAINABLE**

Notice is hereby given under Section 17 (3) of the **Subordinate Legislation Act 1994** that the following Statutory Rules were first obtainable from Information Victoria, 356 Collins Street, Melbourne on the date specified:

23. *Statutory Rule:* Prevention of Cruelty to Animals (Tail Docking of Dogs) Regulations 2004  
*Authorising Act:* Prevention of Cruelty to Animals Act 1986  
*Date first obtainable:* 1 April 2004  
*Code A*

**PRICING FOR SPECIAL GAZETTE,  
PERIODICAL GAZETTE AND  
VICTORIAN LEGISLATION**

Retail price varies according to the number of pages in each Victoria Government Special Gazette, Victoria Government Periodical Gazette and Victorian legislation. The table below sets out the prices that apply.

<i>Price Code</i>	<i>No. of Pages (Including cover and blank pages)</i>	<i>Price*</i>
A	1–16	\$3.70
B	17–32	\$5.50
C	33–48	\$7.55
D	49–96	\$11.75
E	97–144	\$15.20
F	145–192	\$17.95
G	193–240	\$20.70
H	241–288	\$22.05
I	289–352	\$24.80
J	353–416	\$29.00
K	417–480	\$33.10
L	481–544	\$38.60
M	545–608	\$44.10
N	609–672	\$49.65
O	673–736	\$55.10
P	737–800	\$60.65

*\*All Prices Include GST*

**craftsmanpress**

The *Victoria Government Gazette* is published by The Craftsman Press Pty Ltd with the authority of the Government Printer for the State of Victoria

© State of Victoria 2004

This publication is copyright. No part may be reproduced by any process except in accordance with the provisions of the Copyright Act.

Address all enquiries to the Government Printer for the State of Victoria  
Level 2 1 Macarthur Street  
Melbourne 3002  
Victoria Australia

**How To Order**

**Mail Order**      **Craftsman Press Pty Ltd**  
125 Highbury Road  
Burwood 3125  
DX – 32510 Burwood



**Telephone**      (03) 9926 1233



**Fax**      (03) 9926 1292

**email**      [gazette@craftpress.com.au](mailto:gazette@craftpress.com.au)



**Retail & Mail Sales**      **Information Victoria**  
356 Collins Street  
Melbourne 3000



**Telephone**      1300 366 356



**Fax**      (03) 9603 9920



**Retail Sales**      **City Graphics**  
Level 1 520 Bourke Street  
Melbourne 3000



**Telephone**      (03) 9600 0977



**Fax**      (03) 9600 0989

**Recommended Retail Price \$1.95 (includes GST)**

ISSN 0819-5471



9 770819 550218