



Victoria Government Gazette

By Authority of Victorian Government Printer

No. G 15 Thursday 8 April 2004

www.gazette.vic.gov.au

GENERAL

TABLE OF PROVISIONS

Private Advertisements	752	Sales by the Sheriff	756
Estates of Deceased Persons		Said Shaker	756
Aitken Walker & Strachan	752	Rhonda Anne Premasinghe	756
Andrew G. J. Rowan	752	Joanne Mary McLeod	756
Aughtersons	752	Unclaimed Moneys	758
Basile & Co.	752	Diners Club Pty. Ltd.	758
Browne & Co.	752	Madgwicks	787
Cole & Co.	753	Pro Medicus Limited	787
De Marco & Co.	753	Yarra Valley Water Limited	787
Ellinghaus Weill	753	Proclamations	789
Garden & Green	753	Government and Outer Budget Sector	
Gill Kane & Brophy	754	Agencies Notices	790
Gray Friend & Long	754	Orders in Council	850
Harwood Andrews	754	Acts: Crown Land (Reserves);	
John Stewart	754	Interpretation of Legislation;	
Littleton Hackford	754	Victorian Plantations Corporation	
Maddocks	755		
Rennick & Gaynor	755		
Rigby Cooke	755		
Roberts Beckwith Partners	755		
Russo Pellicano Carlei	755		
Sewells Larkins McCarthy	756		
Stidston & Williams Weblaw	756		
Wills & Probate Victoria	756		
Wisewoulds	756		

Advertisers Please Note

As from 8 April 2004

The last Special Gazette was No. 85 dated 7 April 2004.

The last Periodical Gazette was No. 1 dated 12 June 2003.

How To Submit Copy

- See our webpage www.craftpress.com.au
 - or contact our office on 9926 1233
between 8.30 am and 5.30 pm Monday to Friday
-

Copies of recent Special Gazettes can now be viewed at the following display cabinets:

- 1 Treasury Place, Melbourne (behind the Old Treasury Building), and
 - Craftsman Press Pty Ltd, 125 Highbury Road, Burwood 3125
(front of building).
-

**PUBLICATION OF THE VICTORIA GOVERNMENT GAZETTE (GENERAL)
EASTER HOLIDAYS**

Please Note:

The Victoria Government Gazette for Easter week will be published on **Thursday 15 April 2004.**

Copy deadlines:

Private Advertisements **9.30 am on Thursday 8 April 2004.**

Government and Outer
Budget Sector Agencies Notices **9.30 am on Tuesday 13 April 2004.**

Where urgent gazettal is required after hours, arrangements should be made with the Government Gazette Officer on 0419 327 321.

JENNY NOAKES
Government Gazette Officer

PRIVATE ADVERTISEMENTS

RUBY GLORIA PASSAU CRAIG, late of Carnsworth Nursing Home of 10 A'Beckett Street, Kew, Victoria, but formerly of Unit 3, 32 Clendon Road, Toorak, home duties, deceased. Creditors, next-of-kin and others having claims in respect of the estate of the deceased, who died on 16 October 2003, are required by the trustees, Helen Davey of 15B Woodside Crescent, Toorak, Victoria, social worker and Christine Buchanan of 15 Marian Street, Hawthorn, Victoria, developer, to send particulars to the trustees by 11 June 2004 after which date the trustees may convey or distribute the assets, having regard only to the claims of which the trustees have notice.

AITKEN WALKER & STRACHAN, solicitors,
2nd Floor, 114 William Street, Melbourne 3000.

Re: CHARLES EDMUND MORRISON, late of Lyndoch Nursing Home, Hopkins Road, Warrnambool, but formerly of 860 Brunswick Street, North Fitzroy, retired dentist, deceased.

Creditors, next-of-kin and others having claims in respect of the estate of the deceased, who died on 6 December 2003, are required by the trustee, Equity Trustees Limited of Level 2, 575 Bourke Street, Melbourne, Victoria, to send particulars to the trustee by 11 June 2004 after which date the trustee may convey or distribute the assets, having regard only to the claims of which the trustee has notice.

AITKEN WALKER & STRACHAN, solicitors,
2nd Floor, 114 William Street, Melbourne 3000.

MARJORIE BERICE WRAGG, late of Rosanna Views, 269-271 Lower Plenty Road, Rosanna, Victoria, retired typist stenographer, deceased.

Creditors, next-of-kin and others having claims in respect of the estate of the deceased, who died on 1 February 2004, are required by Equity Trustees Limited, ACN 004 031 298, the proving executor of the Will of the deceased, to send particulars of their claims to the executor in the care of the undermentioned solicitor by 9 June 2004 after which date the executor may convey or distribute the assets having regard only to the claims of which it then has notice.

ANDREW G. J. ROWAN, solicitor,
239 Church Street, Richmond 3121.

NORBERT KARL-HEINZ SCHAFER, also known as Norbert Karl Heinz Schafer, late of Unit 11, 67 Mount View Road, Boronia, Victoria, retired, deceased. Creditors, next-of-kin and others having claims in respect of the estate of the abovenamed deceased, who died on 13 February 2004, are required by the executors, Richard Mark De Gille of 31 Allenby Avenue, East Malvern, Peter Charles Milford of 5 The Loch, Croydon Hills, and Glen Andrew Egerton of 21 Milparinka Way, Berwick, to send particulars thereof to them care of the office of Messrs Aughtersons, 267 Maroondah Highway, Ringwood, within two calendar months from the date of publication of this notice, after which the executors will distribute the estate having regard only to the claims of which they have notice.

AUGHTERSONS,
current practitioners for the executors,
267 Maroondah Highway, Ringwood 3134.

Re: Estate of BRADLEY GORDON WHYTE, deceased.

In the estate of BRADLEY GORDON WHYTE, late of 77 Turnours Road, Leitchville, in the State of Victoria, press blenderman. Creditors, next-of-kin and all other persons having claims against the estate of the said deceased are required by Kenneth John Whyte, factory labourer of 6 Station Street, Leitchville, Victoria, the administrator of the estate of the said deceased, to send particulars of such claims to him care of the undermentioned solicitors within two months from the date of publication of this notice, after which date they will distribute the assets having regard only to the claims of which they then have notice.

BASILE & CO., barristers & solicitors,
46 Wellington Street, Kerang, Vic. 3579.

Estate of AUDREY ELLEN CRAZE, deceased.

Creditors, next-of-kin or others having claims in respect of the estate of AUDREY ELLEN CRAZE, late of Unit 2, 19 Silver Street, Cheltenham, in the State of Victoria, home duties, who died on 25 September 2003, are required by Barry Terrance Blake, the proving

executor of the Will of the deceased, to send particulars of their claims to the executor care of the undermentioned solicitors by 9 June 2004, after which date the executor will distribute the assets having regard only to the claims of which he then has notice.

BROWNE & CO., solicitors & consultants,
Level 3, 1 Collins Street, Melbourne, Vic. 3000.

Re: THOMAS HERBERT KELLOCK, late of 2A Warburton Road, East Camberwell, Victoria, bank manager, deceased.

Creditors, next-of-kin and others having claims in respect of the estate of the deceased, who died on 24 August 2003, are required by Equity Trustees Limited, ACN 004 031 298, the proving executor of the Will of the deceased, to send particulars of their claims to the executor, care of the undermentioned solicitors by 10 June 2004 after which date the executor may convey or distribute the assets having regard only to the claims of which it then has notice.

COLE & CO., solicitors,
3 Station Street, Oakleigh 3166.

Re: COLLEEN IVY ROBINSON, also known as Colleen Ivy Hollow and Colleen Ivy Eckhardt, late of Glenlyn Private Nursing Home, 34 Finchley Avenue, Glenroy, Victoria, retired private secretary, deceased.

Creditors, next-of-kin and others having claims in respect of the estate of the deceased, who died on 10 November 2003, are required by the trustee, Joseph De Marco of 209 Glenroy Road, Glenroy, Victoria, solicitor, to send particulars to the trustee within sixty days from the publication hereof, after which date the trustee may convey or distribute the assets, having regard only to the claims of which the trustee has notice.

DE MARCO & CO., solicitors,
209 Glenroy Road, Glenroy 3046.

GLADYS ROSE SINCLAIR (usually known as Jill Sinclair), late of Unit 17.1, No. 193 Domain Road, South Yarra, journalist, deceased. Creditors, next-of-kin and others having claims in respect of the estate of the

deceased, who died on 17 December 2003, are required by the personal representative, Stephen Wilson Bolton of 12 "Bracklyn", 371 Toorak Road, South Yarra, to send particulars to him care of the undermentioned solicitors by 16 June 2004 after which date the personal representative may convey or distribute the assets having regard only to the claims of which he then has notice.

ELLINGHAUS WEILL, solicitors,
79-81 Franklin Street, Melbourne 3000.

CONSTANCE ELLEN VINCENT, late of "Alexandra House", 64 Somerville Street, Bendigo, home duties, deceased. Creditors, next-of-kin and others having claims in respect of the estate of the deceased, who died on 28 September 2003, are required by the personal representative, Hubert Francis Vincent of "Alexandra House", 64 Somerville Street, Bendigo, to send particulars to him care of the undermentioned solicitors by 16 June 2004 after which date the personal representative may convey or distribute the assets having regard only to the claims of which he then has notice.

ELLINGHAUS WEILL, solicitors,
79-81 Franklin Street, Melbourne 3000.

Re: NITA JEAN ALEXANDER, deceased.

Creditors, next-of-kin and others having claims in respect of the estate of the deceased, who died on 28 January 2004, are required by the trustees, Caroline Elizabeth Hillerman and Jennifer Mary Walrton, to send particulars to them by 16 June 2004 after which date the trustees may convey or distribute the assets, having regard only to the claims of which they then have notice.

GARDEN & GREEN, solicitors,
4 McCallum Street, Swan Hill 3585.

Re: AGNES CHARLOTTE LAWSON, deceased.

Creditors, next-of-kin and others having claims in respect of the estate of the deceased, who died on 14 January 2004, are required by the trustee, Margaret Anne Toms, to send

particulars to her by 16 June 2004 after which date the trustee may convey or distribute the assets, having regard only to the claims of which she then has notice.

GARDEN & GREEN, solicitors,
4 McCallum Street, Swan Hill 3585.

Re: DOUGLAS PRESTON COOPER BEDDOW, late of 38 Fakenham Road, Ashburton, Victoria, retired insurance officer, deceased.

Creditors, next-of-kin and others having claims in respect of the estate of the deceased, who died on 27 December 2003, are required by the trustees, Mark John Attard of 34 Barrington Drive, Ashwood and Cameron Richard Roberts of 37 Harts Parade, Hawthorn East, legal practitioners, to send particulars to the trustees by 18 June 2004 after which date the trustees may convey or distribute the assets, having regard only to the claims of which the trustees have notice.

GILL KANE & BROPHY, solicitors,
1/520 Bourke Street, Melbourne 3000.

ELIZABETH CATHERINE BARRETT, late of 14 Tobruk Street, Warragul, Victoria, retired teacher, deceased. Creditors, next-of-kin and others having claims in respect of the estate of the deceased, who died on 26 October 2003, are required by the trustees, Calder Joseph Barrett and Helen Christina Gringhuls, the executors of the Will of the deceased, to send particulars of their claims to them care of the undersigned solicitors by 9 June 2004 after which date the trustees may convey or distribute the assets having regard only to the claims of which they then have notice.

GRAY FRIEND & LONG solicitors,
70 Queen Street, Warragul 3820.

RHETT TYRON JOHN DALY, late of 35 Tolson Street, Teesdale, Victoria, motor mechanic, deceased.

Creditors, next-of-kin and others having claims in respect of the estate of the deceased, who died on 4 September 2003, are required by

the executor of the deceased's estate to send particulars to him care of the undermentioned lawyers by 8 June 2004 after which date the executor may convey or distribute the assets having regard only to the claims of which he then has notice.

HARWOOD ANDREWS, lawyers,
78 Moorabool Street, Geelong 3220.

Creditors, next-of-kin and others having claims in respect of the Will of ELSIE MYRTLE BOAG, late of 44 Market Street, Kensington, Victoria, retired, deceased, who died on 20 February 2004, are requested to send particulars of their claims to the executor, Reginald Albert Boag, care of the undermentioned legal practitioner by 9 June 2004 after which date he will distribute the assets having regard only as to the claims of which he then has notice.

JOHN STEWART, legal practitioner,
290 Racecourse Road, Newmarket.

Creditors, next-of-kin and others having claims in respect of the estate of JUNE MARIE CRABTREE, late of 19 Cameron Street, Traralgon, Victoria, home duties, deceased, who died on 24 March 2004, are to send their claims to the trustee, Andrew John Crabtree of 2 Roseneath Street, Traralgon, Victoria, care of the belowmentioned solicitors by 7 June 2004 after which date he will distribute the assets of the deceased having regard only to the claims of which he then has notice.

LITTLETON HACKFORD, solicitors,
Law Chambers,
115-119 Hotham Street, Traralgon, Vic. 3844.

Re: BESSIE MAVIS WARD, late of 25 Howitt Street, South Yarra, Victoria, gentlewoman, deceased

Creditors, next-of-kin and others having claims in respect of the estate of the deceased, who died on 12 December 2003, are required by the trustees, Perpetual Trustees Victoria Limited, Kathleen Margaret Lindsay Alexander, Allison Lyndon Baensch and Daniel Joseph Ward, to send particulars to the trustees c/- 306 Collins

Street, Melbourne, Victoria by 7 June 2004 after which date the trustees may convey or distribute the assets, having regard only to the claims of which the trustees have notice.

MADDOCKS, lawyers,
140 William Street, Melbourne 3000.

STANLEY GILBERT JONES, late of Eastern Districts Private Nursing Home, 124 Maroondah Highway, Croydon, Victoria, retired, deceased.

Creditors, next-of-kin and others having claims in respect of the estate of the deceased, who died on 7 September 2003, are required by the executor, Leslie Wallace Reid of 504/7 River Street, South Yarra, Victoria, to send particulars to him (care of the undersigned) by 8 June 2004 after which date the executor may convey or distribute the assets having regard only to the claims of which he then has notice.

RENNICK & GAYNOR, solicitors,
431 Riversdale Road, Hawthorn East.

Creditors, next-of-kin or others having claims in respect of the estate of GWENYTH MAY BRAY, late of 28A Albert Street, Traralgon, Victoria, seamstress, deceased, who died on 5 January 2004, are to send particulars of their claims to the executors care of the undermentioned solicitors by 8 June 2004 after which date the executors will distribute the assets having regard only to the claims of which the executors then have notice.

RIGBY COOKE, solicitors,
469 La Trobe Street, Melbourne 3000.

Creditors, next-of-kin or others having claims in respect of the estate of STEPHANIE RUTH HUTCHISON, late of 9/17 Broughton Road, Broughtonlea Nursing Home, Surrey Hills, Victoria, but formerly of Unit 9/6 Essex Road, Surrey Hills, Victoria, retired, deceased, who died on 17 February 2004, are to send particulars of their claims to the executor care of the undermentioned solicitors by 8 June 2004 after which date the executor will distribute the assets having regard only to the claims of which the executor then has notice.

RIGBY COOKE, solicitors,
469 La Trobe Street, Melbourne 3000.

Creditors, next-of-kin or others having claims in respect of the estate of RITA MAY MADDEN, late of 957 Doncaster Road, Doncaster, Victoria, retired, deceased, who died on 9 February 2004, are to send particulars of their claims to the executor care of the undermentioned solicitors by 8 June 2004 after which date the executor will distribute the assets having regard only to the claims of which the executor then has notice.

RIGBY COOKE, solicitors,
469 La Trobe Street, Melbourne 3000.

Re: ELIZABETH SMITH SMART, late of Flat 12, 335 Main Street, Mornington, widow, deceased.

Creditors, next-of-kin and others having claims in respect of the estate of the deceased, who died on 29 December 2003, are required by the trustees, James Smart of 47 Glamorgan Crescent, Mount Martha, Victoria, postal worker, son and Grant Smart of 211 Wiltshire Drive, Kew, Victoria, loss prevention officer, son, to send particulars to the trustees by 8 June 2004 after which date the trustees may convey or distribute the assets, having regard only to the claims of which the trustees have notice.

ROBERTS BECKWITH PARTNERS,
solicitors,
216 Main Street, Mornington 3931.

Re: VARNEY JEAN MOLONEY, late of 120 Uren Road, Emerald, Victoria, home duties, deceased.

Creditors, next-of-kin and others having claims in respect of the estate of the deceased, who died on 13 December 2003, are required by the trustee, Barry James Moloney of 70 Kingston Drive, Dingley, Victoria, to send particulars to the trustee by 10 June 2004 after which date the trustee may convey or distribute the assets, having regard only to the claims of which the trustee has notice.

RUSSO PELLICANO CARLEI, solicitors,
43 Atherton Road, Oakleigh 3166.

Re: ALEXANDER LYLE REID HUGHES, late of Unit 4, 7 Forbes Street, Colac, retired farmer, deceased.

Creditors, next-of-kin and others having claims in respect of the estate of the deceased, who died on 25 December 2003, are required by the deceased's personal representatives, Dulcie Herbalene Flora Harlock, Peter Fraser Falkiner and Noel Stanley Curtis, to send particulars to them care of the undermentioned solicitors by 16 June 2004 after which date the personal representatives may convey or distribute the assets having regard only to the claims of which they then have notice.

SEWELLS LARKINS McCARTHY, lawyers,
119 Murray Street, Colac.

DIANA MOYLE DAWSON, late of 12 Woonton Street, Rosebud, Victoria, deceased. Creditors, next-of-kin and others having claims in respect of the estate of the deceased, who died on 18 November 2003, are required by the trustee, Sam Stidston of Suite 1, 10 Blamey Place, Mornington, Victoria, to send particulars to him by 11 June 2004 after which date the trustee may convey or distribute the assets, having regard only to the claims of which he then has notice.

STIDSTON & WILLIAMS WEBLAW,
solicitors,
Suite 1, 10 Blamey Place, Mornington.

Re: ALFRED VICTOR TENNANT, late of 37 Guild Street, Seymour, Victoria.

Creditors, next-of-kin and others having claims in respect of the estate of the deceased, who died on 4 September 2003, are required to send particulars of their claims to the executor, C/- Wills & Probate Victoria, GPO Box 1946, Melbourne 3001 by 15 June 2004 after which date the executor may convey or distribute the assets having regard only to the claims of which she may then have notice.

WILLS & PROBATE VICTORIA, lawyers,
Level 5, 360 Little Bourke Street, Melbourne.

LOUISA VIOLET McLENNAN, late of 440 Camberwell Road, Camberwell, Victoria, widow, deceased.

Creditors, next-of-kin and others having claims in respect of the estate of the abovenamed deceased, who died on 12 January 2004, are required by the executors Jean Marian Dunn of 282 Canning Street, Carlton North and Robert Tasman Warne Permezal of 40 West Road, Langwarrin South, to send particulars to the executors by 10 June 2004 after which date the executors intend to convey or distribute the assets of the estate having regard only to the claims of which the executors may have notice.

WISEWOULDS, solicitors,
459 Collins Street, Melbourne.

In the Supreme Court of the State of Victoria
SALE BY THE SHERIFF

On Wednesday 12 May 2004 at 2.30 p.m. at the Sheriff's Office, 8-20 King Street, Oakleigh. (Unless process be stayed or satisfied).

All the estate and interest (if any) of Said Shaker of 4 Raimeno Street, Lalor, proprietor of an estate in fee simple in the land described on Certificate of Title Volume 8481, Folio 609 upon which is erected a house known as 4 Raimeno Street, Lalor.

Registered Mortgage No. W877569X affects the said estate and interest.

Terms – Cash/Eftpos
(Debit Card only. No Credit Cards).
SW-03-007159-8

Dated 8 April 2004

V. PARKIN
Sheriff's Office

In the Supreme Court of the State of Victoria
SALE BY THE SHERIFF

On Wednesday 12 May 2004 at 2.30 p.m. at the Sheriff's Office, 8-20 King Street, Oakleigh. (Unless process be stayed or satisfied).

All the estate and interest (if any) of Rhonda Anne Premasinghe also known as Rhonda Anne Dewsnap of 19 Hardy Avenue, Cannons Creek as shown on Certificate of Title as Rhonda Ann Dewsnap, joint proprietor with Donald William

D'Olivera of an estate in fee simple in the land described on Certificate of Title Volume 9077, Folio 857 upon which is erected a house known as 19 Hardy Avenue, Cannons Creek.

Registered Mortgage No. S840513W affects the said estate and interest.

Terms – Cash/Eftpos
(Debit Cards only/No Credit Cards).

SW-03-006406-3

Dated 8 April 2004

V. PARKIN
Sheriff's Office

In the Supreme Court of the State of Victoria

SALE BY THE SHERIFF

On Wednesday 12 May 2004 at 2.30 p.m. at the Sheriff's Office, 8–20 King Street, Oakleigh. (Unless process be stayed or satisfied).

All the estate and interest (if any) of Joanne Mary McLeod of 57 Park Boulevard, Ferntree Gully, joint proprietor with Alexander McLeod of an estate in fee simple in the land described on Certificate of Title Volume 8597, Folio 328 upon which is erected a house known as 57 Park Boulevard, Ferntree Gully.

Registered Mortgage No. AB629722X and Caveat No. AC374350T affect the said estate and interest.

Terms – Cash/Eftpos
(Debit Cards only/No Credit Cards)

SW-03-009301-5

Dated 8 April 2004

V. PARKIN
Sheriff's Office

Unclaimed Moneys Act 1962

Register of Unclaimed Moneys held by the —

<i>Name of Owner on Books and Last Known Address</i>	<i>Total Amount Due to Owner</i>	<i>Description Of Unclaimed Money</i>	<i>Date when Amount first became Payable</i>
DINERS CLUB PTY LTD			
	\$		
Mr Roy Graham-Measor, 742 Andover Way, Karrathwa, WA	100.01	Cheque	05/07/98
Mr Andrew P. Newman, 5/31 Addison Road, Manly, NSW	100.02	"	10/03/96
Mr Hidetake Yamauchi, Hakuhodo Australia Pty Ltd, 4/76 Berry Street, North Sydney, NSW	100.03	"	24/07/00
Mr Mark Keohane, 27 Everview Avenue, Mosman, NSW Shell Fourways, corner of Nebo Road & Bridge Road, Mackay, Qld	100.06	"	13/04/96
Mr Geoffrey L. Leighton, GPO Box 95, Buronga, NSW	100.44	"	27/11/01
Mrs Deborah Sheldon, 19 Haven Court, Cherrybrook, NSW	100.52	"	12/08/02
BP Kawana, Nicklin Way and Wyanda Drive, Bokarina, Qld	100.54	"	22/12/02
Mr Javier Santamarta, Unit 15, 14–16 Hercules Road, Brighton Le Sands, NSW	100.65	"	26/11/01
Mr Derek A. Whithy, 39 Emerald Street, Emu Plains, NSW	100.94	"	02/04/01
Mr R. Davis, C/- Storage Tek, PO Box 725, Artarmon, NSW	100.97	"	20/03/97
Mr Fred Butt, PO Box 55, Cloncurry, Qld	101.61	"	06/08/95
Ms Mary P. Cavanough, 8 Penrose Street, Lane Cove, NSW	101.68	"	06/06/02
Mr Richard A. Cairns, 13 Ocean Road, Manly, NSW	101.79	"	29/04/99
Ms Louise Husin, GPO Box 92B, Melbourne	101.84	"	02/12/96
Mr Michael J. Webb, 1 Carter Avenue, Nunawading	101.96	"	08/04/02
Ms Meg McKnight, P. G. and E., 33/1 Eagle Street, Brisbane, Qld	102.00	"	08/10/01
Mr Stuart K. Macaree 18 Doveridge Drive, Duncraig, WA	102.06	"	09/05/98
Cairo Express, 113 Lake Street, Cairns, Qld	102.11	"	24/12/96
Mr Stephen T. Croft, 2 Sara Court, Bayswater North	102.14	"	18/11/01
Miss Joanna Finlay, 40 Rosser Street, Rozelle, NSW	102.32	"	27/01/98
Peakhurst Inn Pty Limited, 705 Forest Road, Peakhurst, NSW	102.40	"	30/09/02
Ms V. Feyen, IMR Worldwide, Level 7, 10 Queens Road, Melbourne	102.58	"	04/09/01
Matson Automotive Industries, Attn Mr B. D. Mathieson, PO Box 905, St Mary's, NSW	102.69	"	29/06/00
Mr Peter Doura-Manis, 11 Magnet Court, Sandy Bay, Tas.	103.00	"	04/12/02
Mr John A. Parker, 16 Corrie Road, North Manly, NSW	103.05	"	06/03/02
Mr Raymond L. Beven, 56 Laitwood Road, London SW12 9QJ, United Kingdom	103.10	"	08/07/02
Mr Thomas R. Seymour, Coopers & Lybrand, PO Box 5007, Gold Coast Mail Centre, Qld	103.11	"	16/12/00
Budget Eyewear, 123 Camberwell Road, Hawthorn East	103.20	"	01/06/97
Mr Simon Greig, 110 Tanjong Rhu Rd, #08.02 Camelot, Singapore 436928	103.47	"	24/01/02
Mrs C. D. Dooley, 89 Rippingale Road, Korora Basin, NSW	103.48	"	09/05/02
Mr J. Bryce, 257 Pipers Brooke Road, Lebrina, Tas.	103.75	"	21/10/00
	104.02	"	06/04/99

Mr J. N. Varigos, 5/37 High Road, Camberwell	104.06	''	03/07/94
Mr T. Hattori, C/- Opal Spectrum (Duty Free), 37 Pitt Street, Sydney, NSW	104.22	''	18/07/96
Marine Power Aust P/L, 132-140 Frankston Road, Dandenong	104.22	''	28/02/98
Mr N. Corrigan, 390 The Entrance Road, Long Jetty, NSW	104.28	''	27/02/94
Mr Timothy D. Murray, C/- Mrs Michelle Murray, 4th Floor, Wade House, Merrion Centre, Leeds, UK	104.36	''	23/12/96
Mr David L. King, 2/1422 Gregory Street, Wendouree	104.40	''	25/02/02
Mr Jag Rewal, 18 Murray Road, Ormond	104.58	''	06/11/01
Mr Mark A. Harrison, IBM GSA, 60 City Road, Southbank	104.61	''	25/10/01
Shell Roadhouse Leonora, Tower Street, Leonora, WA	104.76	''	14/12/01
Mr Allan Norton, ISSC Australia, GPO Box 2628, Sydney, NSW	104.78	''	14/10/97
Shell Roadhouse Leinster, Mainsbridge Street, Leinster, WA	104.79	''	14/12/01
Just Eat It, 300 New Street, Brighton	104.82	''	14/02/02
Dr Nedeljko Gecan, 271 Lakes Road, Greenfields, WA	104.90	''	05/01/02
Fisons Pharmaceuticals, PO Box 6263, Baulkham Hills, NSW	104.95	''	06/03/97
Mr M. Thompson, 49 Richardson Street, Lane Cove, NSW	105.22	''	22/01/01
Mr R. J. Linton, 2 Waratah Court, Drouin	105.24	''	28/04/96
Ampol Largs Bay, 26 South Terrace, Semaphore, SA	105.29	''	02/10/01
Mrs Jane M. Starr, 1/28 Stanton Road, Mosman, NSW	105.42	''	21/08/02
Mrs Katheryn Neylon, 10/1 Princess Street North, Richmond Shell Middle Swan,	105.49	''	25/11/02
45 Great Northern Highway, Middle Swan, WA	105.79	''	06/06/01
Mr Mauro Compagnoni, Mauro Compagnoni, PO Box 302, Regents Park, NSW	105.84	''	22/03/98
Mr Stafford M. Bent, 10 Cameron Avenue, Altona Meadows	106.24	''	21/04/01
Caltex Lakemba, Punchbowl & Wangee Road, Lakemba, NSW	106.40	''	06/07/01
Mrs Y. Glover, 39 Saltburn Road, Milford, Auckland, New Zealand	106.57	''	03/11/98
Cronan & Hallenan Air Conditioning, 21 Jardine Street, Fairy Meadow, NSW	106.63	''	30/01/97
Hardman Australia Pty Ltd, C/- Bowden Books P/L, 54A Fitzroy Street, Marrickville, NSW	106.63	''	27/10/97
Mrs Gail C. O'Sullivan, Ningaloo Reef Resort, Coral Bay, WA	106.70	''	12/08/98
Ms Angela V. Davies, 237 Leura Mall, Leura, NSW	106.72	''	28/04/00
Mr A. J. Young, 14th Floor, Wardell Chambers, 39 Martin Place, Sydney NSW	106.77	''	18/06/95
Mr Dan M. Becheru, 36 Kastelan Street, Blacktown, NSW	106.90	''	07/11/02
Port Smith Bottle Shop, 63 Aumuller Street, Cairns, Qld	107.10	''	21/12/01
Mr J. Arii, C/- Mitsubishi Co. Singapore, 138 Robinson Road, #09 Hong Leong Centre, Singapore	107.29	''	02/12/02
Mr Alec S. Gardner, 44 Elliot Road, Menai, NSW	107.39	''	31/08/98
Mr Wayne W. Sidwell, Show-Ads Omega Pty Ltd, 359 Plummer Street, Port Melbourne	107.41	''	17//11/99
Mr Daniel J. Tour, IBM Global Services, PO Box 4060, Croydon Hills	107.64	''	09/03/02
Mr Mark S. Bode, PO Box 184, St Ives, NSW	107.73	''	14/05/98
Mr Michael A. Muscat, Oral-B Laboratories, Locked Bag 40, Goulburn, NSW	107.92	''	02/12/98
Miss Kirsten N. Dally, 4/30 McFarlane Crescent, Epping	108.00	''	10/10/97
Ms M. Teti, 48 Edmund Road, Highbury, SA	108.01	''	03/07/99

Mr P. M. Foster, 18 Buckland Street, Holland Park, Qld	108.06	''	05/03/97
Dr Trevor M. Fayers, 1 Kalinga Street, Clayfield, Qld	108.10	''	14/02/01
Mr Kyle Mangini, 93/1 Diethelm Tower A, 13th Floor, Wireless Road, Patumwan, Bangkok, Thailand	108.65	''	19/12/96
Metric Australia Pty Ltd, Att: Valmae Cross, PO Box 232, Midland, WA	108.85	''	02/05/01
Mr David I. Higgins, 10 Baringa Avenue, Seaforth, NSW	109.24	''	17/07/00
Mr David J. Denby, IOOF Funds Management, GPO Box 246C, Melbourne	109.34	''	24/07/01
Miss Karen Jacobsen, PO Box 23, Double Bay, NSW	109.36	''	05/11/01
Mr Stephen R. Magor, The Oberoi, Dr Zakir Hussain Marg, New Delhi, India	109.37	''	19/11/96
Dr Iain G. Stewart, 75 Swan Street, Morpeth, NSW	109.80	''	31/01/97
Currie & Brown (Australia), Level 2, 441 St Kilda Road, Melbourne	109.86	''	24/06/99
Elliott P. Fyfe Concrete CU, 23-25 Dixon Street, Sunnybank, Qld	110.00	''	28/12/96
Miss Sarah E. Newcombe, 3 Slater Place, Evatt, ACT	110.00	''	06/03/97
Mr Robert J. Bremner, 48 Quiguy Crescent, Churchill	110.00	''	19/03/97
Mr Alan Schulz, 302 Sampson Avenue, Paraburdoo, WA	110.00	''	22/03/97
Mr David R. Smith, 4 Woodchester Close, Castle Hill, NSW	110.00	''	28/04/97
Mr Matthew J. Taylor, U14/11 River Street, Richmond	110.00	''	29/04/97
Mr David G. Watts, 545 Caves Road, Busselton, WA	110.00	''	23/05/97
Mr Brian F. March, 1 McGill Street, Evatt, ACT	110.00	''	25/10/97
Mr Neil F. Rooney, 1 Beaton Street, Warilla, NSW	110.00	''	06/06/98
Mr Ronald B. McKittrick, 41 Garnet Avenue, Blackwood, SA	110.00	''	31/07/98
Grifton Pty Ltd, Attn Gwen Hatton, PO Box 59, Rye	110.00	''	22/12/99
Thin Air Pty Ltd, PO Box 2479, Burleigh MDC, Qld	110.00	''	24/04/01
Mr Paul Quinlan, PO Box 1604, Nhulunbuy, NT	110.00	''	18/03/02
Mayer Krieg, Locked Bag 3, Civic Square, Croydon	110.00	''	16/12/02
Mr P. R. Annetts, 5 Nan Street, Box Hill	110.02	''	22/04/95
Becu Wool Trading Co. Pty Ltd, 7 Sandgate Road, Blackburn South	110.02	''	09/12/97
Mr David Geoffrey Berry, Trakka Pty Ltd, 3 Short Street, NSW	110.07	''	02/12/95
Mr Taneer Aiyub, 4/82 Doncaster Road, Balwyn North	110.07	''	20/07/97
Snowmaster P/L, 2 Lyons Road, Drummoyne, NSW	110.07	''	17/09/98
Mr John D. Taylor, 14A Maitland Street, Glen Iris	110.07	''	05/02/02
Miss Jennifer A. Lowe, 116 Simpson Avenue, Rockingham, WA	110.08	''	18/01/98
Mr F. Balboni, C/- Diners Club Return Mail, GPO Box 5088, Melbourne	110.20	''	07/12/02
Mr Michael Teys, GPO Box 2912, Sydney, NSW	110.42	''	16/11/01
Mr James N. Kosturos, 25 Rose Parade, Mount Ousley, NSW	110.63	''	06/05/97
Mr James N. Kosturos, Mount Ousley, NSW	110.63	''	06/05/97
Demi View Motel, 41 Front Street, Mossman, Qld	110.77	''	08/06/01
Mr John M. Turner, 111 Eyre Street, Seaview Downs, SA	110.84	''	09/07/94
Mrs Lydia Paczynski, Citibank Limited, PO Box 40, Sydney, NSW	110.87	''	01/02/02
Mrs Hilary J. Weaver, 6/25 Pacific Highway, Roseville, Sydney, NSW	111.29	''	01/10/97
Art Infusion, 562 Malvern Road, Prahran	111.49	''	07/01/02

Mr Anthony J. Chisholm, 108 /40 Stathalbyne Drive, Oatlands, NSW	111.69	”	25/04/02
Mr Roland Bruss, 20 Ardrossan Loop, Kingsley, WA	111.71	”	17/08/00
Mr R. W. Briggs, C/- Qantas, 77 St Georges Terrace, Perth, WA	112.56	”	19/07/98
Mr N. Christie-David, C/- Diners Club Return Mail, PO Box 5088, Melbourne	112.68	”	07/11/01
Mr Sam Yeates, P P M A, GPO Box 4149, Sydney, NSW	112.86	”	25/05/99
Dr Trevor J. Roberts, PO Box 4007, Marketplace Post Shop, Bendigo	113.07	”	24/08/99
Mr Stephen D. Pollock, 9/215 Alma Road, East St Kilda	113.07	”	21/06/01
Ms Catherine E. Allen, La Signy Farm, RD4 Morrinsville, New Zealand	113.13	”	12/04/00
The Gift, 49 Bermuda Street, Gold Coast Mail Centre, Broadbeach Waters, Qld	113.14	”	11/07/02
Mr Frank Cheung, Townhouse 5, 57 Garling Street, Lane Cove, NSW	113.20	”	14/01/97
Mr David Keys, 81 Lee Street, North Carlton	113.28	”	25/03/00
Shell Kardinya Car Spa, North Lake Road, Kardinya, WA	113.64	”	14/12/01
Mr Andrew D. Syme, 10 Proudfoot Street, Mont Albert	113.72	”	06/11/01
Mr Daryl D. Denny, 36 Wanaka Drive, Taylors Lakes	113.77	”	17/07/00
Mr Wayne E. Phipps, PO Box 1318, Midland, WA	114.00	”	09/12/02
Mr Ashley B. Freeman, 1/293 Camberwell Road, Camberwell	114.06	”	23/12/98
Dr H. A. Fisher, 5 Kamber Road, Terrey Hills, NSW	114.60	”	02/04/02
Applied Chemicals, Attn Shirley Halim-Harjono, Private Bag 35, Wantirna	114.78	”	10/01/02
Mr S. Toth, PO Box 146, Bentleigh	115.05	”	30/08/98
Mr Kenneth Arthur Maish, Rams Home Loans, Locked Bag 100, Royal Exchange, NSW	115.07	”	09/10/00
Better Brakes, 282 Chapel Road, Bankstown, NSW	115.09	”	06/07/01
Ms Sarah A. Mort, 28A Montague Street, Balmain, NSW	115.43	”	08/02/01
Ms Sarah E. Ropper, 8504 Browning Court, Annandale, Virginia, USA	115.45	”	10/04/02
The Canyons Restaurant, 1 Ternmby Road, Nelson Bay, NSW	115.56	”	12/07/01
Miss Lynette R. Perry, 26 Inglebar Avenue, Allambie Heights, NSW	115.58	”	09/07/02
Mr J. R. Bryant, Jillamatong Spring Drive, Corrowa, NSW	116.29	”	03/10/97
Peak Edgewater, 21 Edgewater Drive, Edgewater, WA	116.35	”	03/12/01
Mr N. J. D. Flett, Rogan Australia, Level 3, Unit 4/14 Aquatic Dr, Frenchs Forest, NSW	116.37	”	18/09/94
Mr Damian Babis, 3A 75 Blue Pool Road, Happy Valley, Hong Kong	116.63	”	19/01/02
Ms Barbara J. Jackson, 3 Wellesley Drive, Kirwan, Qld	116.90	”	24/09/02
Mr Daniel C. Binstead, 32 David Street, Thorneside, Qld	116.90	”	04/11/02
Mr Colin Matchett, Myer 1327000 Network Store Man, Megamart, 295 Lonsdale Street, Melbourne	117.00	”	01/11/01
Mr John P. Harvey, 14 Hurds Hill Road, Coromandel Valley, SA	117.00	”	24/10/02
Mrs Libbi M. Kern, PO Box 5418, Gladstone, Qld	117.00	”	22/11/02
Mr Nevene Jayatilaka, 4/194-218 Lawrence Street, Alexandria, NSW	117.00	”	25/11/02
Able Industries Pty Ltd, PO Box 132, Newport	117.00	”	04/12/02

Mr Matthew F. Hayes, Energy Developments, PO Box 83, Appin, NSW	117.57	”	18/12/01
Mr Ron Dunn, 3 Dawn Court, Glen Waverley	117.80	”	07/11/01
Ms Helen Newell, Coles Supermarkets, 800 Toorak Road, Tooronga	118.12	”	01/06/96
Mr David A. Callander, NCR Australia, 289 Burnley Street, Richmond	118.19	”	26/08/02
Mrs Immacolata Gangemi, 10 Margaret Street, Oak Park	118.57	”	05/10/99
Mr David M. Gange, Bi-Lo Pty Ltd, *Attn H. Adamson, PO Box 670, Blair Athol, SA	118.69	”	07/08/95
Mr Lance J. Farrelly, 124 Mattocks Road, Burleigh Waters, Qld	118.93	”	27/02/99
Mr D. A. J. Hull, 20 Goode Street, Dubbo, NSW	119.12	”	21/04/96
Caltex The Gap, 680 Waterworks Road, The Gap, Qld	119.15	”	01/11/01
Mr R. J. Stanley, S. J. Electric Queensland, 19 Elliot Street, Albion, Qld	119.81	”	26/01/98
Swift & Moore P/L—Vic., Attn Ann Smart, Locked Bag 11, Villawood, NSW	120.00	”	10/05/02
Simsmetal Ltd, PO Box 4155, Sydney, NSW	120.00	”	21/10/02
Mr David A. Lows, PO Box 7181, Hutt Street, Adelaide, SA	120.07	”	13/12/96
Ms Susan B. Beattie, Shell Refining (Australia), Refinery Road, Corio	120.07	”	01/10/01
Ampol Pacific Fair, 2612 Gold Coast Highway, Broadbeach, Qld	120.21	”	04/10/01
Mr Anton E. Wespe, PO Box 201, Edge Hill, Qld	120.30	”	15/05/99
Shell Highway Roadhouse, 1–3 Broadsound Road, Mackay, Qld	120.50	”	27/11/01
Mr John A. Carroll, 1 Woodford Street, Longueville, NSW	120.53	”	29/01/99
Ms Lynne M. Goldie, 10/18 Station Road, Williamstown	120.84	”	09/03/98
Mr J. Ho, 60 Cecil Street, Kew	121.15	”	06/05/97
The Oasis Road House, Bruce Highway, Guthrilungra, Qld	121.22	”	31/07/01
Mr Ulrich Kuerfgen, 54 The Boulevard, Morwell	121.44	”	24/07/01
Mr S. R. Archibald, Fuller Tool Co. of Australia, 25 Staple Street, Seventeen Mile Rocks, Qld	121.62	”	28/01/96
Ms Nicole Sann, PO Box 243, Bellingen, NSW	121.97	”	19/03/01
Mr Benjamin B. Lane, Unit 1/9 Ken Payne Place, Parkes, NSW	122.00	”	30/03/02
Shell Cairns South, 540 Mulgrave Road, Woree Cairns, Qld	122.74	”	27/11/01
Mr I. Brown, 7 Siglap Road, 22–60 Mandarin Gardens, Singapore	122.99	”	23/06/99
Mrs Hilary J. Ellis, PO Box 187, Carinbah, NSW	123.15	”	17/03/00
Mr David Scurr, 8 Warwick Street, Killara, NSW	123.21	”	22/05/94
Mr David R. Buckley, Seerpharma P/L, Suite 3, Level 1, 818 Whitehorse Road, Box Hill	123.25	”	28/09/01
Mr Martin Scollon, PO Box 170, Balwyn	123.73	”	07/06/02
Ms Patricia H. Parker, 43 Phillips Street, Alexandria, NSW	123.91	”	26/06/02
Mr Stephen Thomas Mills, RMB 2790, Numurkah	124.16	”	19/03/02
Mr C. R. Smith, C/- Readers Digest Aust P/L, PO Box 4353, Sydney, NSW	124.37	”	10/06/99
Mr W. F. Cornford, PMP Communications Limited, PO Box 758, Hawthorn	124.45	”	28/01/95
Dr Jennifer Cawson, Diners Club In House Fraud, Hartwell	124.55	”	12/01/97
Emils Hair & Beauty, 39 John Lund Drive, Hope Island, Qld	124.68	”	16/01/02

Mrs Patricia L. Simpson, 13 Ashton Crescent, Hoppers Crossing	124.71	''	22/12/02
Ms L. M. Keenan, Rowland (Qld) Pty Ltd, 18/127 Creek Street, Brisbane, Qld	124.76	''	12/06/01
Mr C. Li, 97 Canning Street, Launceston, Tas.	124.85	''	29/06/99
Mr G. F. Beveridge, 18 Leon Street, Cheltenham	125.00	''	09/07/97
Mr D. Stojanovic, 21 Queens Parade, Hillside	125.00	''	17/07/97
Mr Timothy Kasbe, 4311 Mill Village Road, Raleigh 27612, North Carolina, USA	125.00	''	08/05/98
Mr Scott H. Edwards, 56 Parramatta Road, Doubleview, WA	125.00	''	14/08/98
Mr Ronald A. Prowse, 4/32-36 Evelyn Street North, Sylvania, NSW	125.00	''	17/11/98
Estate of J. McCafferty, McCafferty Service Centre, 28-30 Neil Street, Toowoomba, Qld	125.00	''	20/03/99
Mr A. J. Phelan, 21 Chester Road, Claremont, WA	125.00	''	19/04/99
Mr Norihide Shirovani, 1/10 Clyde Street, Glen Iris	125.00	''	05/06/99
Mr Gregory B. Lambert, 60 Cliff Road, Frankston	125.00	''	26/08/99
Mr James T. Rew, 123 Haig Street, Ipswich, Qld	125.00	''	04/09/99
Mr William Luckett, 5 Oberon Court, Hillbank, SA	125.00	''	09/11/99
Mr John Eckardt, PO Box 225, Noosa Heads, Qld	125.00	''	23/11/99
Mr Yoshihiro Watabe, 5A/37 Reynolds Street, Cremorne, NSW	125.00	''	14/02/00
Mr R. L. Ives, C/- Leasecorp P/L, PO Box 2254, St Kilda West	125.00	''	13/04/00
Mr David C. Rice, PO Box 73, Midland, WA	125.00	''	28/06/02
Mr J. H. Gordon, 3/9 Jardine Street, Kingston, ACT	125.08	''	15/01/98
Mr J. Fitzhardinge, Box 3326, Manuka, ACT	125.08	''	31/03/99
Dr Hayden G. Morris, PO Box 1391, Collingwood Jag North Sydney, Shops P28-30, Greenwood Plaza, Pac. H/Way, North Sydney, NSW	125.21	''	11/06/02
Rotary Club Maribryngong Highpoint, PO Box 168, Highpoint City	125.81	''	26/06/01
Mr Malcolm Lasky, Boral Construction Materials, PO Box 42, Wentworthville, NSW	125.81	''	14/10/02
Dr Huw R. Davies, Queen Elizabeth Hospital, 28 Woodville Road, Woodville, SA	125.92	''	13/04/00
Miss Sarah M. Edwards, 2/229 Avoca Street, Randwick, NSW	125.93	''	17/10/02
Shell Cairns North, 291 Sheridan Street, Cairns, Qld	126.03	''	03/10/00
Mr B. G. Cooper, 4 Barrington Road, Terrigall, NSW	126.43	''	29/11/01
Mr Steven R. Taylor, 62 Faheys Road West, Albany Creek, Qld	126.46	''	27/11/00
Mr R. Gillen, Glenbrook, RMB694, Cherry Gardens Road, Cherry Garden, SA	126.84	''	18/05/99
Mrs Alison Butler, QBE Mercantile Mutual, 85 Harrington Street, The Rocks, Sydney, NSW	126.97	''	01/04/97
Mr Roy Jacob, ISSC Australia, 1822 Dandenong Road, Clayton	126.98	''	02/08/00
Ms Celine S. Y. Teo, IBM Australia Limited, 2/1060 Hay Street, West Perth, WA	127.06	''	27/03/99
Perri Cutten, 770 Military Road, Mosman, NSW	127.32	''	13/02/01
Mr Bosco H. L. Tran, 5 Alexander Street, Prospect, SA	127.74	''	28/10/02
Mr Phillip Troughton, 8 Camden Court, Glen Waverley	127.93	''	06/09/99
	128.19	''	11/12/00

Shell Cairns Depot Driveway, corner of Kenny & Draper Street, Cairns, Qld	128.40	''	27/11/01
Mr I. J. O. Maguire, PO Box 193, Emerald, Qld	128.41	''	10/09/00
Everything Australian, Shop 9, Mezzanine Level, Aust. Airlines Terminal, Melbourne Airport	128.42	''	09/01/02
Mr Lawrence R. Wilson, 15 Fairview Place, Mt Kuring-Gai, NSW	128.62	''	25/04/97
Mr David E. Peake, IBM Australia, Level 21/60 City Road, Southbank	128.97	''	13/11/00
Mr Alexander R. M. McFarlane, 38 Kyarra Road, Glen Iris	129.33	''	23/08/99
Classic Formal, 1256 High Street, Armadale	129.48	''	13/06/02
Ian Elcock Optometrists, Shop 60, Ground Level, Garden City, Kessels Road, Mt Gravatt, Qld	129.75	''	01/11/01
Canterbury-Bankstown Rugby, Attn Robert Snoch, PO Box 123, Belmore, NSW	130.00	''	22/11/02
Mr Peter J. Meichelboeck, Were Holdings, GPO Box 2050s, Melbourne	130.05	''	24/12/02
Remtex Pty Limited, PO Box 32, Wallsend, NSW	130.09	''	13/02/97
Miss Alexandra Zentveld, Carlson Marketing Group, PO Box 7170, St Kilda Road, Melbourne	130.16	''	14/02/01
Beach Culture Australia, Shop 314, Airside, Brisbane International Airport, Eagle Farm, Qld	130.21	''	12/06/01
Mr Leslie M. Sayers, Castlemaine Perkins, GPO Box 44, Brisbane, Qld	130.90	''	10/10/01
Mr Don Rudd, Rex Highway, Julatten, Qld	131.62	''	24/12/96
Dr E. J. Rowland, 14 Skene Street, Hamilton	131.74	''	17/11/97
BP Coffs Harbour, 136 Pacific Highway, Coffs Harbour, NSW	131.76	''	02/08/01
Mr William K. Renshaw, Lot 571 Queen Street, Muswellbrook, NSW	131.87	''	27/07/96
Dr B. Boman, 1/313 Victoria Place, Drummoyne, NSW	132.08	''	15/09/96
Miss Jodie L. Day, NCR Australia, 8-20 Napier Street, North Sydney, NSW	132.42	''	31/03/99
Ms Heather J. Ferguson, 13 Morrissey Road, Erskineville, NSW	132.68	''	20/08/02
Mrs Tania Castrissios, Myer 1220000 Network, Store Man. Blacktown, 295 Lonsdale Street, Melbourne	132.70	''	13/08/01
Rubys Arms, PO Box 248, Belgrave	132.83	''	01/05/02
Mr Richard W. Bithell, 14 Abercrombie Crescent, St Agnes, SA	132.95	''	19/03/01
Mr Michael G. Riddell, GPO Box 2429, Canberra, ACT	133.44	''	25/04/97
Ms Deborah M. Trewick, 2/9 Robertson Street, Parramatta, NSW	133.47	''	21/03/97
Ms Jeannette Lang, Transfield Holdings Pty Ltd, 437 St Kilda Road, Melbourne	133.48	''	29/05/01
Dr D. J. Cooper, Waite Agricultural Institute, Glen Osmond, SA	133.90	''	05/02/95
Mr M. R. Douglas, 90 Eucumbene Drive, Duffy, ACT	133.97	''	15/02/97
Mr Peter B. Wade, PO Box 3006, Kew	134.72	''	16/10/02
Wadkin Australia, Attn Narend Sharma, PO Box 63, Cannon Hill, Qld	135.00	''	21/03/01
Mr Keith Moss, Va Eimco Australia P/L, 30 John Street, Belmont North, NSW	135.48	''	15/06/02
Mr Peter L. Weis, 34 Baty Street, St Lucia, Qld	135.70	''	04/02/97

Mr Nick Libertone, 1/88 Dundas Street, Thornbury	135.74	''	15/01/01
Mrs Fiona M. Elliott, Australian Petroleum, C/- Ian Nicol, GPO Box 3916, Sydney, NSW	136.44	''	10/01/98
BP Express Merrimac, corner of Gold Coast & Springbrook Roads, Merrimac, Qld	136.56	''	07/01/02
Mr David J. Gale, 5 Peartree Place, Knoxfield	136.68	''	12/10/99
Mr Todd S. Wills, Unit 5/4 Paxton Street, East Malvern	137.00	''	23/11/96
Ian Elcock Optometrists, Shop 26, Centenary Shopping Centre, Dandenong Street, Mt Ommaney, Qld	137.19	''	06/07/01
Ms Athanasia Polyzos, 60 Park Crescent, Caulfield North	137.25	''	24/04/97
BP Burpengary, Bruce Highway, Burpengary, Qld	137.56	''	27/11/01
Dr D. Kahans, 672 Main Road, Eltham	137.57	''	27/03/02
Mr James M. Shean, PO Box 64, Howard Springs	137.58	''	11/12/02
Mr Stephen A. Nault, 10 Linckens Crescent, Balwyn	137.75	''	03/12/99
Mr Kym R. Pfitzner, DMB&B, 349 Bulwara Road, Ultimo, NSW	137.78	''	23/07/98
Mr A. E. Prior, 3/12 Flavell Street, Concord, NSW	138.88	''	26/05/96
Mr Garry Horner, DDB, 76 Berry Street, Sydney, NSW	138.93	''	22/10/02
Mr G. McRobert, Homat Excelsior 203, 4-11 Mita 2-Chome Minato-Ku, Tokyo, Japan	139.12	''	02/12/02
Mr Daniel M. Sackers, Ashton Mining Ltd, 21 Wynyard Street, Belmont, WA	139.91	''	08/11/99
Wye River Clothing, Shop 29, Sunbury Square, Evans Street, Sunbury	139.94	''	03/12/00
Mr B. Batchelor, Smorgon Consolidated Ind. P/L, 433-451 Somerville Road, West Footscray	140.00	''	11/06/95
Mr Romano C. Ditoro, 8 Luciella Court, North Dandenong	140.00	''	30/04/99
S. F. Construction Pty Ltd, 31 Liverpool Street, Ingleburn, NSW	140.00	''	21/08/01
The Climax Group, 10 Braun Drive, Hanndorf, SA	140.00	''	16/11/01
Taylor & Herbert P/L, 204 Willoughby Road, Crows Nest, NSW	140.00	''	21/03/02
Swift & Moore P/L-Qld, Attn Ann Smart, Locked Bag 11, Villawood NSW	140.00	''	10/05/02
Volvo Construction, Attn Melissa Walsh, PO Box 1033, Chatswood, NSW	140.00	''	04/06/02
Van Der Graaf Industries P/L, Hattam Street, Golden Square	140.00	''	25/10/02
Rand Technologies Pty Ltd, 17 Business Park Drive, Notting Hill	140.00	''	04/12/02
Don Clark Tractors P/L, 915 Castlereagh Road, Castlereagh, NSW	140.00	''	17/12/02
Howard Silvers, Locked Bag 75, Wetherill Park, NSW	140.04	''	29/07/98
Mr Craig S. Sageman, 13 Thomas Street, Eltham	140.05	''	04/07/02
Mr John Cully, L40 St Western Highway, Westmead, NSW	140.08	''	19/09/94
Mr Brett D. Adler, Tandem Computers Pty Ltd, 1/1 Napier Close, Deakin, ACT	140.61	''	21/04/96
Mr T. Crowe, Unit 1/56 Yarrimbah Drive, Nerang, Qld	140.65	''	18/11/95
Mr John A. Oulton, Iamavet, PO Box 6306, Acacia Ridge DC, Qld	141.08	''	01/03/01
Mr Tony Budge, 27 Wrigley Street, Dianella, WA	141.28	''	24/05/02
Mr Alex Butera, Ixos Software Aust Pty Ltd, Level 4, 580 St Kilda Road, Melbourne	142.43	''	24/12/02

Mr Vincenzo P. Saccone, PO Box 98, Fremantle, WA	142.65	''	31/07/01
Mrs Catherine G. Heness, 24 Rose Street, Armadale	142.69	''	17/05/00
Mr Peter Wyatt, PO Box 637, Tennant Creek, NT	142.70	''	22/01/02
Mr Michael E. Spiteri, 12 Bridle Place, Pakenham	142.98	''	25/10/99
Mrs Denise Barham, Unit 18/40–42 Houston Road, Kingsford, NSW	143.45	''	21/11/02
Mr Paul K. H. O'Young, Suite 5, Level 10, 84 Pitt Street, Sydney, NSW	143.65	''	20/11/01
Mr John K. Horsfall, 15 Hume Street, Upwey	143.85	''	10/04/02
Miss Suzanne M. Coutinho, 1 Gloria Close, Mount Colah, NSW	143.88	''	21/08/02
Mr David J. Boyle, Lion Nathan Australia, Locked Bag 14, Royal Exchange, NSW	144.00	''	09/10/01
Mr D. J. Alley, 28 Golf Avenue, Mona Vale, NSW	144.28	''	07/01/96
Mr Stephen J. Baker, 9 Pinecone Court, Bunya, Qld	144.46	''	05/02/00
Ms Pauline C. Lockwood, IMB Australia, 2 Peck Road, North Richmond, NSW	144.46	''	17/05/00
The Outdoor Furniture, Shop 9/12 Upton Road, Bundall, Qld	144.58	''	19/11/01
Ms Lisa K. O'Mara, 99/438 Forest Road, Hurstville, NSW	144.80	''	30/06/00
Mrs Diana M. Hense, 5 Mariposa Place, Port Melbourne	145.00	''	24/05/00
Mr A. V. N. Ede, Unit 30, Windermere Tower, Harbour Road, Hamilton, Qld	145.00	''	06/07/00
Mr Stewart N. Mayhew, 188 Delgado Parade, Iluka, WA	145.00	''	12/02/01
Mr Paul C. Bownas, 6 Largs Street, Seaford	145.00	''	11/07/01
Mr J. Wayne Miller, 16 Pavlovich Court, Wattleup, WA	145.00	''	30/08/01
Mr John A. Murray, 32 The Grove, Mosman, NSW	145.00	''	11/09/01
Mr P. Safe, PO Box 179, Tin Can Bay, Qld	145.00	''	22/02/02
Mr J. P. Logan, C/- Ocean Development Bank, PO Box 789, Manila, Phillipines	145.00	''	27/03/02
Mr David M. Statham, 74 Central Park Avenue, Canning Vale, WA	145.00	''	09/04/02
Mr Brendon Michael Hubble, 2/68 Southside Drive, Hillarys, WA	145.00	''	09/04/02
Mrs Joanna Bader, 80 O'Neill Street, Guildford, NSW	145.00	''	18/04/02
Mr Ronald L. Lingard, 4 Como Court, Buderim, Qld	145.00	''	30/04/02
Mr R. J. Sandry, 142 Jacobs Drive, Sussex Inlet, NSW	145.00	''	21/06/02
Mr Charles Wright, 10 Mashie Way, Wodonga	145.00	''	24/06/02
Mr Don Clark, 49 Gap Road, Riddells Creek	145.00	''	02/07/02
Mr Michael A. Hopper, 12 Henry Street, Loxton, SA	145.00	''	04/07/02
Mr John Paul Jones, 31 Gloucester Street, Victoria Park, WA	145.00	''	25/07/02
Mr Timothy P. Christie, PO Box 3576, Manuka, ACT	145.00	''	04/08/02
Dr Siva Kangaratnam, PO Box 431, Lithgow, NSW	145.00	''	30/10/02
Rick Hart Event, 58 Guthrie Street, Osborne Park, WA	145.16	''	31/08/01
Oshkosh B'Gosh Parramatta, Shop 2041, Westfield Shoppingtown, Parramatta, NSW	145.16	''	19/12/01
Mr Andrew C. Graham, 139 Brisbane Street, Bulimba, Qld	145.19	''	31/05/00
J. A. Hartley Shopfitters P/L, 154–158 Arthur Street, Fortitude Valley, Qld	145.38	''	04/12/02
Shell Select Alexander Park, Cnr of Wallcott Street & Fitzgerald Street, Mount Lawley, WA	146.52	''	14/12/01
Mr G. F. Carmody, Containers Packaging, PO Box 2398, Abbotsford	146.58	''	13/12/96
Mr Roderick C. Morris, Locked Bag 3, Parramatta, NSW	146.91	''	02/12/02

Mrs Stephanie Stach, 33 Currawong Avenue, Normanhurst, NSW Tower Service Station, Gull 45,	146.97	''	29/11/01
Cnr of Bourke & Maritana Street, Kalgoorlie, WA	147.31	''	18/12/01
Ms Donna Wang, C/- IBM, Attn Alfred Youssef, Tg 27, Level 27/300 La Trobe Street, Melbourne	147.45	''	26/08/98
Mr Dale L. Middleton, 2 First Avenue, East Kew	147.53	''	19/04/99
Mrs C. I. M. Judd, 29 Rona Street, Peakhurst, NSW	148.64	''	10/04/02
Mr Attel R. Martschinke, Flat 9, 70 Barker Street, New Farm, Qld	149.25	''	15/03/02
Miss Evelyn J. Barry, Vox Retail, 8 Hudson Avenue, Castle Hill, NSW	149.75	''	14/09/99
Hamish Drummond & Assoc., 17C Billyard Avenue, Wahroonga, NSW	150.09	''	27/09/00
Mr Geoffrey W. Sengstock, Thiess Pty Ltd, 5/40 McDougall Street, Milton, Qld	150.92	''	01/05/02
Beauty at the Bay, Shop 4, 118 Jetty Road & Cowper Street, Glenelg, SA	151.34	''	14/02/02
Mr Scott M. Bennison, GPO Box 3414, Sydney, NSW	151.36	''	29/04/02
Mr Kym Skripal, 132 Clarkes Road, Enfield	151.82	''	13/03/02
Mr G. P. Wilson, CPI Papers, PO Box 12182, Penrose, Auckland, New Zealand	151.99	''	09/11/96
Mr Ronald P. Overstreet, 1020 Church Street, 2 San Francisco, CA	152.07	''	24/06/95
City Motor Holdings Pty Ltd, Attn Tony Sitch, Cnr Huntingdale & Dandenong Roads, Oakleigh	152.13	''	31/07/02
Dr Robert J. Young, C/- Diners Club Return Mail, GPO Box 5088, Melbourne	152.34	''	31/07/02
Mr G. F. Orchard, PO Box 51, Bracken Ridge, Qld	152.64	''	30/08/98
Mr John E. Merry, 13 Dehavilland Avenue, Strathmore Inroads Fairfield,	153.40	''	06/11/02
Unit 2, 2 Claremont Avenue, Greenacre, NSW	153.70	''	23/10/02
Mr Jason L. Myers, 4 Christians Avenue, Avonsleigh	154.58	''	17/01/02
Dolly G. Toowoomba, Shop 37, Clifford Garden Shopping Centre, Toowoomba, Qld	154.74	''	16/12/02
Mr Shanker Ramamurthy, 515 East, 72 Street, Apt 3J New York, USA	154.90	''	12/05/99
Mr Mark A. Singer, 6 Lucas Street, Caulfield	155.37	''	01/08/02
Ms K. L. Welsh, 6/58 Peach Street, Greenslopes, Qld	155.77	''	31/12/98
Dr R. B. Feller, 82/177 Bellevue Road, Double Bay, NSW	155.80	''	11/10/02
Mr P. J. Shakespeare, PO Box 1242, Surfers Paradise, Qld	155.89	''	03/12/98
Mr Adam J. Watkins, 35 Farrar Street, Acacia Ridge, Qld	155.95	''	28/10/98
Mr A. Backwell, C/- Joanna Morley, 35 Linden Way, Castlecrag, NSW	156.03	''	09/07/99
Mr J. E. Potter, 9 McDowall Street, Bongaree, Bribie Island, Qld	156.34	''	22/07/97
Mr Robert J. Cameron, Trowbridge Consulting Ltd, 38/1 Macquarie Place, Sydney, NSW	156.51	''	11/07/01
Lockwood Partners, PO Box 561, Echuca	157.05	''	24/04/01
Business Park, PO Box 7082, Brighton	158.25	''	08/04/02
Shell Wattle Autoport, Corner of Hurley & Sutttons Streets, Cootamundra, NSW	158.50	''	26/05/01
Mr Alexander C. Robertson, 28 Kennedy Street, Appin, NSW	158.63	''	15/06/01

Mr Saurabh Mishra, 8/19 Redan Street, St Kilda	158.64	''	06/07/00
Forrester Parker Group Ltd, GPO Box 2447, Brisbane, Qld	159.27	''	04/12/02
Onslow Engineering, PO Box 6607, Silverwater, NSW	159.39	''	29/06/01
Mr R. T. Breen, C/- Breen Chiropractic Clinic, 148 Rundle Mall, Adelaide, SA	159.98	''	02/03/97
Mr P. D. Holmes, 132 Progress Road, Eltham	160.05	''	24/02/00
Mr K. McDonald, Apartment 78-4-6 Block A, Faber Heights, Jalan Desa Utama, Taman Desa, Kuala Lumpur	160.49	''	02/12/02
Mr Tasnor I. Bull, Trade Union Training Authority, Thomas Street, Sydney, NSW	160.59	''	18/03/97
Mr James G. B. Armstrong, AWA Defence Industries P/L, Building 233, "Industrial Area", Salisbury, SA	160.66	''	06/08/97
Mr Ross Smith, 10 Strelitz View, Beeliar, WA	160.98	''	23/01/01
IT Australia, Attn Des Smith, PO Box 445, Moorabbin	161.03	''	13/04/00
Mr B. S. Upton C/- Byrncut Mining P/L, PO Box 1669, Kalgoorlie, WA	161.20	''	09/04/95
Mr S. Ferraro, PO Box 1004, Narre Warren	161.82	''	26/07/01
Noel Long Pty Ltd, PO Box 1232, Camberwell	162.00	''	28/10/02
Yokohama Tyre Aust P/L, PO Box 247, Rydalmere, NSW	162.40	''	04/02/95
Tightrope, 3/450 Chapel Street, South Yarra	162.90	''	10/05/02
Mr Steven A. White, 5 Sydney Street, Clayton	163.29	''	28/12/99
Caltex Griffith, 2-4 Mackay Avenue, Griffith, NSW	163.72	''	19/07/01
Beach Culture, Sydney International Airport Departure, Qantas Domestic Terminal, Mascot, NSW	164.00	''	12/06/01
Mr T. Stokie, 17 Lone Pine Avenue, Umina, NSW	164.10	''	25/08/98
McArthur Management Services P/L, 1/199 Toorak Road, South Yarra	164.35	''	30/03/99
Mrs Janet M. Spurrell, PO Box 146, Warrandyte	164.36	''	02/01/01
Kevin J. Curtin & Partners, Level 2, 52 Atchison Street, St Leonards, NSW	165.00	''	13/04/98
Nadavoc Industries PO Box 166, Mitcham	165.00	''	12/10/99
Spalding Australia Pty Ltd, Attn Lorraine Gemmill, PO Box 18-24, Knoxfield MDC	165.00	''	19/02/01
Mrs Marilyn C. Leermakers, World Vision of Australia, 1 Vision Drive, East Burwood	165.10	''	25/04/97
Mr T. H. Cordwell, RSD 2010, Grove Huon, Tas.	165.21	''	29/11/98
Mr Frank Calvo, C/- Diners Club Return Mail, PO Box 5088, Melbourne	165.25	''	13/11/02
Mr Rob Wagner, IBM Global Services, 7 Valonia Drive, Eltham	165.45	''	07/05/99
International Insulation, 20 Murdoch Avenue, Mulgrave	166.12	''	24/04/01
Ms Michelle Tierney, Byvan (NSW) Pty Ltd, PO Box N366, Grosvenor Place, Sydney, NSW	166.83	''	06/09/01
Mr Robin G. Vincent, 138 Crossmaglen Road, Crossmaglen, NSW	166.84	''	26/07/02
Mr Robert C. Crowley, PO Box 218, Mittagong, NSW	167.00	''	05/11/02
Shell Brentwood Self Serve, Corner of Moolylen Road & Cranford Avenue, Brentwood, WA	167.01	''	14/12/01
Mr A. V. Parry, PO Box 435, Avalon, NSW	168.02	''	06/11/94
Target Australia Pty Ltd, Attn: Karen Smith, Target Australia, PO Box 41, North Geelong	168.07	''	18/08/99
Mr Akio Ogawa, NEC Australia, 635 Ferntree Gully Road, Glen Waverley	168.55	''	19/03/97

Mr Leo P. Rennie, Telstra Corporation, Level 13, Rialto Building, 525 Collins Street, Melbourne	168.60	''	01/12/02
Ms Sarah J. Thompson, Lion Nathan, Locked Bag 14, Royal Exchange, NSW	168.61	''	10/10/01
Beach Culture, Cairns International Airport, Cairns, Qld	168.78	''	12/06/01
D'Arcy Australia Pty Ltd, 5/349 Bulwara Road, Ultimo, NSW	168.79	''	10/04/02
Mr Paul A. McAuliffe, C/- BGM Surveys, PO Box 842399, Houston, Texas, USA	168.85	''	02/12/02
Mr David P. Bowers, PO, Box 277, Artarmon, NSW	169.10	''	15/01/95
Mr D. E. Krause, 72 Learmonth Street, Strathpine, Qld	170.00	''	07/05/98
Ms Marie Abela, 11 Wexford Court, Keilor Downs	170.00	''	30/12/98
Mr P. L. Jones, Askriegg, Gretna, Tas.	170.00	''	29/10/99
Peter Law Aust P/L, PO Box 150, Mascot, NSW	170.31	''	10/12/97
Mr Tony Mitchell, Nabalco Pty Ltd, Attn A. Avila, PO Box 21, Nhulunbuy, NT	170.50	''	28/07/96
Shell Hugh Street, 174 High Street, Currajong, Qld	170.94	''	27/11/01
Shell Griffith Self Serve, 6-10 Mackay Avenue, Griffith, NSW	171.95	''	06/06/01
Mr Max Astri, PO Box 381, Dubbo, NSW	173.68	''	30/10/02
Shell Aberdeen, 68 McQueen Street, Aberdeen, NSW	173.93	''	09/12/01
Mr Nicholas P. Eddy, 13 Clevedon Court, Kew	174.90	''	17/03/97
Mr John H. Woods, Bartercard Pty Ltd, C/- Anita Jakins, Finance, Bartercard Pty Ltd, Qld	175.33	''	01/10/01
Dr Aniket D. Patel, PO Box 676, Kensington, NSW	175.64	''	18/11/01
Ms Jennifer Meiselman, C/- Julie Fowler, 1 Neil Circle Natick, Ma, USA	175.92	''	12/04/97
Mr Lui Fraietta, IBM Global Services, 2/601 Pacific Highway, St Leonards, NSW	176.62	''	11/12/01
Shell Bicton Auto Care, 394 Canning Highway, Bicton, WA	176.72	''	04/12/01
Mr Glenn Reid, 5 Sutherland Avenue, Wahroonga, NSW	177.02	''	26/09/98
BP South Maryborough, Bruce Highway, Maryborough, Qld	177.56	''	27/11/01
Mr Bruce R. Meehan, 11 Grange Avenue, Canterbury	178.33	''	30/03/99
Mr M. Pinnock, 19 Vakuta Street, Fig Tree Pocket, Qld	178.41	''	02/04/95
Mr P. Scapens, HBA, 293 Camberwell Road, Camberwell	178.47	''	13/03/98
Mr Nigel Dolan, PO Box 500, Angaston, SA	178.52	''	26/02/02
Mr Steven Sellings, 9/2A Charlotte Place, Illawong, NSW	178.55	''	11/10/01
Dr P. K. Y. Lee, C/- Diners Club Return Mail, 1193 Toorak Road, Hartwell	178.81	''	11/12/02
Mr A. G. Hetherington, Nestle, 24 Tralee Street, Hume, ACT	179.92	''	18/01/02
Unifi Communications Aust, Attn Account Payable, PO Box K514, Haymarket, NSW	179.94	''	16/06/99
Cody Outdoor Pty Ltd, C/- Cody Outdoor Pty Ltd, Level 8, 468 St Kilda Road, Melbourne	179.97	''	25/10/02
Mr Stuart R. Carson, 1/8 Addison Road, Manly, NSW	180.79	''	15/01/97
Mr Peter Camilleri, 223 Antill Street, Watson, ACT	181.97	''	24/03/01
Vic. Indept Education Union, Attn Jaswinder Kaur, PO Box 1320, South Melbourne	182.00	''	19/12/02
Mr David Growcott, 271A Avonhead, Christchurch, New Zealand	182.16	''	12/04/00
Advantage Petroleum, Corner of Bong Bong & Bowral Streets, Bowral, NSW	182.81	''	24/05/01
Dr Peter J. Langkamp, 26 Churchill Avenue, Cheltenham	183.48	''	19/03/97
Mallesons Stephen Jaques, Level 60, Governor Phillip Tower, 1 Farrer Place, Sydney, NSW	183.67	''	14/10/99

\			
PO Box Q1496, QVB Post Shop, Sydney, NSW	198.20	''	30/07/99
Mr G. P. Thomas, 1333 Bonita Avenue, Mountain View, California, USA	198.55	''	13/01/00
Mr Ian F. Inguanez, Attn Mrs J. Conroy, Level 5, 5 Queens Road, Melbourne	199.00	''	07/07/99
Ms Simone A. Shirley, Toyota Australia, PO Box 187, Caringbah, NSW	199.35	''	07/03/01
BHP Steel—BIPD, Merchandising Head Office, Locked Bag 10, Five Dock, NSW	200.00	''	03/12/02
Dr Martin C. M. Lin, PO Box 490, Westmead, NSW	200.23	''	17/11/01
South Cronulla Cellars, 32 Ewos Parade, Cronulla, NSW	201.03	''	05/09/01
Chanel Press P/L, PO Box 568, Sunshine	201.74	''	01/10/01
BP Express Rozelle, 86 Victoria Road, Rozelle, NSW	201.80	''	04/08/01
Mr Timothy L. Congelliere, Hawker De Havilland, GPO Box 779H, Melbourne	201.90	''	05/02/02
Ms Karen M. Moore, 3/1 Cremorne Road, Cremorne Point, NSW	202.33	''	20/08/98
Mr Stephen Grealish, 6 Ashford Street, Ashfield, NSW	202.38	''	09/08/01
Mr Steven R. Riley, 39 Aristos Way, Marangaroo, WA	202.42	''	08/12/98
Mr Peter Thanopoulos, Amway of Australia, PO Box 202, Castle Hill, NSW			
Mr R. J. Rowland, Parsonage Cottage, 39 Church End, Biddenham, Bedford, England	205.79	''	18/12/96
Mr Colin Owens, Advance Funds Management, Level 1/333 Collins Street, Melbourne	206.84	''	22/07/98
Ms Nicole E. Murtagh, 26/3 Mosman Street, Mosman, NSW	207.82	''	26/11/98
Mr C. E. Peaty, 5 Luth Avenue, Daglish, WA	208.12	''	30/07/95
Indulgence by Natasha Lee, Natasha Lee, 15 Duke Street, Woonoona, NSW	208.12	''	23/08/02
Mrs W. G. Bowen-Jones, 3/83 West Esplanade, Manly, NSW	209.40	''	18/12/97
Ampol Slacks Creek, 109 Paradise, Slacks Creek, Qld	209.54	''	05/06/01
JB Hi Fi Group, 1/14 Spink Street, Brighton	209.78	''	12/06/01
Mr Richard V. Gazzard Camberwell Coal Pty Ltd, Private Mail Bag 7, Singleton, NSW	210.10	''	26/07/98
Heath Fielding Australia, Level 2, 65 Berry Street, North Sydney, NSW	210.97	''	24/04/01
Mr Geoffrey A. Sparks, IBM Global Services, PO Box 395, Castlemaine	210.97	''	14/01/02
Mrs Katherine Jackson, IBM Global Services, 12 Alfred Street, Woolwich, NSW	211.33	''	13/03/00
Hogs Breath Cafe, 5 Victoria Street, Bunbury, WA	211.67	''	19/07/01
Mr Robert Basilius, 107 Boundary Street, Rosevil, NSW	211.70	''	29/12/98
Mr James R. Wilkinson, 11 Alamav Street, Benowa, Qld	212.49	''	27/08/95
ID Tours—South Pacific, 4/30 Atchison Street, St Leonards, NSW	214.36	''	24/12/01
Franklins 126 Pagewood, Bunnerong Road & Banks Avenue, Pagewood, NSW	216.52	''	18/09/01
Mr Nicholas J. Adams, 10/2 Newlands Street, Wollstonecraft, NSW	217.84	''	20/10/00
Mr Mark Keene, C/- Bkr Walker Wayland, PO Box 1805, West Perth, WA	217.88	''	13/02/02
Allied Plant Services Pty, PO Box 243, Fairy Meadow, NSW	218.14	''	01/12/96

Mr Manoj Murugan, 199/221 Regent Street, Redfern, NSW	218.83	''	06/05/00
Melb Diagnostic Imaging Gr, Locked Bag 2000, Surrey Hills Beach Culture,	220.07	''	30/08/00
Airside Pier B, Sydney Int. Airport, Mascot, NSW	221.98	''	11/06/01
Mr Kevin R. MacKenzie, 30 The Anchorage, Noosa Waters, Noosaville, Qld	222.27	''	16/01/01
Mr Terrance Paroz, Locked Bag 3687, Brisbane, Qld	222.34	''	02/12/02
Mr August B. Lembong, Pacific View, Block 5, Flat 11A, 38 Tai Tam Road, Hong Kong	222.46	''	30/12/99
Mr M. Pailthorpe, 11 Lorne Avenue, South Penrith, NSW	222.73	''	19/12/96
Mr Peter D. Tarrant, 15A Inverleith Street, Hawthorn	223.36	''	14/12/00
Mr Danny D. Cash, 7 Frazier Close, Concord West, NSW	223.52	''	13/11/00
Ms Helen M. Noble, 65 Park Road, Naremburn, NSW	225.50	''	29/10/02
Ms Diana R. Godson, PO Box 212, North Fremantle, WA	226.61	''	04/11/99
Mr Stephen M. Brown, Locked Bag 6579, Sydney, NSW	226.99	''	17/11/97
Dymocks, 705-707 Hay Street Mall, Perth, WA	227.42	''	20/08/01
Mr Michael Van Kerckhof, 8 Templemore Drive, Templestowe Cafe Brulee, 1/28 Grimes Street, Auchenflower, Qld	228.44	''	16/07/97
Mr Shaun T. Hicks, 58 Wragby Road, London, United Kingdom E1131B	229.96	''	27/10/97
Mr Michael A. Kluczko, Sussan Corporation (Aust), GPO Box 490G, Melbourne	230.14	''	21/03/97
Mr Mark C. Cooper, Tooheys Limited, 67 Henry Lawson Avenue, Werrington, NSW	230.14	''	10/10/01
Mr Geoff Noblett, KPMG, 161 Collins Street, Melbourne	230.20	''	11/12/00
Miss Julia Sham, 22 Bruxner Place, Doonside, NSW	230.56	''	22/05/98
Fleming Consulting Pty Ltd, Watton Street, Penhurst	231.34	''	14/05/95
Advantage Petroleum, 65 Hume Hwy, Lansvale, NSW	232.92	''	08/06/01
Mr John M. Strode-Smith, 93 Amarina Avenue, Ashgrove, Qld	233.99	''	13/01/00
Mr T. Andjal, 2 Lee Court, Wodonga	234.50	''	18/11/99
Mr Bob Newey, Woolworths, Attn Anne Jensen, Locked Bag 11, Fairfield, NSW	235.81	''	07/08/01
Mr David J. Stanhope, Box 24, Robe, SA	236.73	''	19/05/00
Mr Stephane E. Thiroloix, 79 Pentecost Avenue, Pymble, NSW	237.10	''	25/03/96
Mr Peter L. Wright, 20 Gordon Crescent, Blackburn	238.16	''	03/03/01
Dr David C. Cousins, C/- KPMG(Andrea Searle), 2nd Level, 161 Collins Street, Melbourne	238.57	''	16/09/99
Mr Andrew Mitchell, 4 Heather Place, Quakers Hill, NSW	238.98	''	17/05/00
Mr Benjamin J. Reece, 23/96 Alfred Street, Milsons Point, NSW	239.12	''	21/02/00
Mr G. Cole, 2A Catalpa Crescent, Turramurra, NSW	240.00	''	05/06/02
Mr David A. Petersen, Compair Australasia Ltd, PO Box 126, Mount Waverley	241.51	''	17/11/00
BP Bribie Island, Corner of Goodwin Drive & Hornsby Road, Bribie Island, Qld	242.06	''	27/11/01
Mr J. Davey, 3 Marlborough Close, Terrigal, NSW	242.09	''	01/06/97
Mr Keith H. Collier, PO Box 490, Carnarvon, WA	244.75	''	24/11/00
Mr Mark R. Ramsey, Technology Transaction Pty Ltd, GPO Box 3354, Sydney, NSW	246.22	''	15/04/97
Ms Debra L. Connelly, Citibank, Attn Cynthia Lee, Level 26/2 Park Street, Sydney, NSW	247.33	''	06/03/02
Mrs Kerry Muharen, Bi Lo, 64 Parramatta Road, Underwood, Qld	247.55	''	13/03/01

James McManus & Associates, PO Box Z5451, St Georges Terrace, Perth, WA	247.80	''	28/02/02
Mr Leszek Maciejewski, PO Box 270, Norseman, Norseman, WA	248.60	''	05/08/02
Mr Evan Gibson, 16 George Street, Preston	248.70	''	23/07/02
Mr Patrick Michael Rafter, 295 Handford Road, Taigum, Qld	248.78	''	30/10/02
Mrs Caterina Gadaleta, Boral Energy, 60 Waymouth Street, Adelaide, SA	249.98	''	18/05/99
Mr Timothy C. S. Moore, 48 Lyons Street, Cottesloe, WA	250.00	''	06/04/98
Mr C. C. Macmillan, PO Box 37306, Winnellie, NT	250.05	''	24/09/94
Burraneer Bay Cellars, 147 Woolooware Road, Cronulla, NSW	250.25	''	05/09/01
Mr Paul A. W. Fell, 8C First Street, Bicton, WA	250.84	''	23/03/01
Mr Alan J. Morrison, 6 Kookaburra Close, Innisfail, Qld	251.15	''	08/01/02
Geoffrey R. Braimbridge P/L, 74 Ward Street, Kalgoorlie, WA	251.96	''	11/04/00
Blayne Tyre Service P/L, 19 Adelaide Street, Blayne, NSW	253.48	''	20/10/01
BP Maroochydore, 51-55 Aerodrome Road, Maroochydore, Qld	254.37	''	26/11/01
Shell Warwick Auto Care, 274 Erindale Road, Warwick, WA	254.77	''	04/12/01
Mr Jesse Das, 4 Milbanke Street, Portland	255.53	''	14/05/02
Mr Leslie P. Joyce, Locked Bag 2, Home Hill, Qld	255.58	''	02/12/02
Golden Harvest Rest, 744 North East Road, Holden Hill, SA	255.98	''	14/10/02
Mr Andrew S. Dale, 4 Bentham Street, Mount Gravatt, Qld	256.62	''	06/11/01
Mr Trevor J. Andrews, 11 Artell Close, Raymond Terrace, NSW	258.20	''	14/10/99
Lugarno Cellars, 1020 Forest Road, Lugarno, NSW	258.81	''	05/09/01
Mr John Stathouros, 3/103 Kangaroo Road, Oakleigh	259.23	''	05/03/98
Broome Checkpoint, Corner of Hamersley & Napier Streets, Broome, WA	259.76	''	14/12/01
Mrs Mary T. O'Dwyer-Smith, 48 Turriell Point Road, Lilli Pilli, NSW	260.00	''	03/12/01
Dr J. O. Knight, 32 The Boulevard, Floreat, WA	260.16	''	03/06/95
Mr B. N. Stott, 83 Charles Street, Moonah, Tas.	260.16	''	03/09/95
Mr Mark T. Fayle, 292 Edgeware Road, Newtown, NSW	260.16	''	18/12/00
Mr P. J. Furneyvall, PO Box 32, Bowraville, NSW	260.56	''	24/09/99
Mr Peter A. Kirchner, PO Box 212, Moonee Ponds	260.93	''	02/12/00
Mr Steen E. Kristensen, CRA Exploration, 4 Research Avenue, Bundoora	261.10	''	27/03/98
Mr Brian J. Blechynden, Compair (Aust.) Limited, 15 Banach Street, Maddington, WA	261.26	''	27/08/98
Mr Ian Smith, 6/212 Alison Road, Randwick, NSW	261.87	''	19/11/00
Leach Motors Service, 143 Newmarket Road, Windsor, Qld	261.92	''	01/09/01
Ms Wendy A. Chapman, PO Box 39, Como, WA	263.35	''	27/12/02
Mr David B. Moss, 5 Jenkins Close, North Ringwood	263.98	''	31/08/95
Mr Christopher R. Johnson, Dyno Wesfarmers Ltd, Locked Bag 2113, North Sydney, NSW	264.13	''	28/07/01
Ms Anna Greco, New York Bag, Locked Bag 40, Queen Victoria Terrace, Parkes, ACT	264.30	''	24/12/96
Mr Patrick J. Donohoe, 2/4 Stillman Street, Richmond	266.76	''	02/12/02
Mr Allan J. Edge, IBM Global Services, 601 Pacific Highway, St Leonards, NSW	267.59	''	11/07/00
Ms Dana K. Namir, 20 Oakley Street, North Bondi, NSW	267.86	''	20/08/02

Mr Tristram J. Gray, Coles Supermarkets Aust P/L, PO Box 480, Glen Iris	267.91	”	16/12/97
Mr Christopher J. Latham, Coopers & Lybrand (Act) P/L, 580 George Street, Sydney, NSW	268.11	”	05/05/99
Mr R. D. Butterss, Fraud, Hartwell	268.29	”	14/09/96
Mr Andrew J. K. Morrison, Rams Home Loans, Locked Bag 100, Royal Exchange, NSW	270.56	”	02/05/00
Mr Robert T. De Beer, Alfa-Laval Pty Ltd, PO Box 37, Pendle Hill, NSW	274.20	”	31/12/00
Jag Cairns, Shop C3 & C4, The Market Place, Pier Point, Cairns, Qld	274.22	”	26/06/01
Mr J. A. Terrill, RSD 1390, Browns Plains	274.34	”	16/01/97
Liberty Liquor Rouse Hill, Lot 1, Rousehill S/C, Corner of Mileend Road & Windsor Road, Rouse Hill, NSW	276.04	”	25/06/01
Mr Rodney B. Birchall, 38 Popperwell Drive, Menai, NSW	278.45	”	13/12/00
Perfect Posture Injury Mng, 800 Beaufort Street, Mt Lawley, WA	279.08	”	31/12/01
Mr John M. P. Robinson, PO Box 70, Mooloolaba, Qld	279.19	”	27/01/02
Mr Paul W. McCormack, 85 Cribbes Road, Wangaratta	279.65	”	29/09/99
Swift & Moore P/L NSW, Attn Ann Smart, Locked Bag 11, Villawood, NSW	280.00	”	10/05/02
Pony Express Holdings P/L, PO Box 180, Sydney Markets, NSW	280.00	”	13/06/02
Mr John W. Tregaskis, ALH Electrical Group, PO Box 319, Heidelberg	280.17	”	11/06/99
Mr Nathan O'Reilly, Attn Siobhan Walsh, GPO Box 557, Sydney, NSW	280.31	”	14/11/02
Mr Stephen M. Drummond, 66 Oliver Street, Harbord, NSW	280.98	”	26/01/01
Mr Edward Yue, Level 10, 2 Part Street, Sydney, NSW	283.41	”	24/09/02
Mr David R. Lucy, Origin Energy, Level 1/1 King William Street, Adelaide, SA	283.60	”	25/07/01
Mr Simon John Flowers, 123 Harold Street, Thornbury	283.69	”	02/05/99
Mr John A. Baker, Coles Myer Ltd, 800 Toorak Road, Tooronga	283.70	”	26/10/00
Mr Christopher J. Bolt, 5 Delray Avenue, Wahroonga, NSW	284.18	”	06/04/96
Odin Mining (Aust) Pty Ltd, Attn Mr S. Middlemas, 2nd Floor, CSA Centre, 445 Hay Street, Perth, WA	284.54	”	04/12/02
BP Mooloolaba, 180 Brisbane Road, Mooloolaba, Qld	285.43	”	27/11/01
Ms Jacqueline Gill, PO Box A1454, Sydney South, NSW	285.88	”	20/09/00
Summit Holiday Apartments, Corner of Leichhardt & Allenby Streets, Spring Hill, Qld	286.19	”	11/04/02
Cafe Mediterranean, Caloundra City Centre, 55 Bulcock Street, Caloundra, Qld	287.20	”	01/11/01
Design Fashion Australia, Unit G, 134–140 Old Pittwater Road, Brookvale, NSW	288.11	”	28/11/01
Mr Ian J. Bowden, Australian Federal Police, PO Box 168, Manly, NSW	288.45	”	29/08/00
Malcolm Pacific Pty Ltd, 19 Goodwood Drive, Keilor Downs	289.96	”	23/12/99
Mr Andrew D. Proud, 5/1 Avenue Road, Mosman, NSW	290.50	”	26/03/99
Mr Mark W. Stevens, 12 Ferrier Place, Kambah, ACT	291.05	”	14/01/96
Sunnybank Flight Centre, Shop 32A, Sunnybank Plaza, Mains Road, Sunnybank, Qld	293.59	”	23/07/01

Mr D. W. Squires, C/- Hagen & Co., 5 Harewood Yard, Harewood, Leeds, United Kingdom	293.85	''	13/09/02
Mr Shigeki Matsushima, 9 Prince Arthur Mews, London, NW3 1RD United Kingdom	294.76	''	17/07/94
Mrs Susan J. Warren, Level 13, 628 Bourke Street, Melbourne Outdoor Mgmt Development, 26 Mountview Road, Ferny Creek	295.00	''	27/05/98
J. & B. Petroleum, Lot 1, Windsor Road, Vineyard, NSW	295.00	''	23/12/99
Mr Matthew J. O'Brien, Huxbury Quinn Group, PO Box 1013, Milton BC, Qld	295.94	''	29/05/01
Mr M. J. Cannon-Brookes, IBM Australia (Fd41), PO Box 400, Pennant Hills, NSW	296.30	''	10/05/01
Mr D. J. Francis, Terrace 11, 22/26 Grattan Street, Carlton	296.59	''	07/10/97
Ms Cindy G. Farrelly, BP Solarex Pty Ltd (Solar), Attn Kelly Robinson, 2 Australia Ave, Homebush Bay, NSW	298.75	''	04/02/96
Beach Culture, 105 George Street, The Rocks, Sydney, NSW	299.09	''	29/04/02
Mr G. Delbridge, PO Box 971, Rockingham, WA	299.13	''	12/06/01
Mr D. Grant, 30 Hickson Road, Sydney, NSW	299.31	''	02/09/95
Mr George A. Paton, 40 Kalakau Avenue, Forrester's Beach, NSW	300.00	''	21/06/02
Mr Rick J. Phelps, 35 Wellington Street, Richmond Lagoona Pty Ltd, Box 306, Cecluna, SA	301.07	''	06/07/00
Miss D. A. Evans, Belmont Bloodstock Agency Pty, PO Box 6200, Hay Street, Perth East, WA	301.59	''	16/06/00
Raquel's Roadhouse, RMB 213, Western Highway, Tramalla	302.22	''	04/12/02
Ms Genevieve Simmonds, Provet Limited, 10 Buchanan Road, Banyo, Qld	302.28	''	01/04/98
Ms S. Pitkin, 43 Watson Street, Wilston, Qld	302.52	''	10/01/02
Mr Martin J. Forrest, Level 1/4 Park Road, Qld	302.98	''	06/10/01
Miss Joanne Ching-Yi Leung, 28 Knighbridge Avenue, Nunawading	303.01	''	09/11/96
Kellyderm Pty Ltd, 243 Kooyong Road, Toorak	303.18	''	05/12/97
Mrs Kirsten A. Brebner, Flight Centre, 1/134 Racecourse Road, Ascot, Qld	303.60	''	04/12/00
Mr Charlie T. Salloum, 14 Thames Street, Glenroy Ambition Clothing Co., Shop 116, Paradise Centre, Surfers Paradise, Qld	306.33	''	03/04/02
Mr Ross M. Lisle, PO Box 7841, Toowoomba, Qld	308.09	''	20/02/01
Mr Marcus C. Blackmore, Blackmores Ltd, PO Box 258, Balgowlah, NSW	308.15	''	12/05/98
Mr A. Cuthbertson, Centre for Intern Economics, GPO Box 2203, Canberra, ACT	308.25	''	27/06/01
Mr Aron Walles, 20 Denman Avenue, East St Kilda Jag Chatswood, Shop 4237, Chatswood Chase Shopping Centre, 345 Victoria Avenue, Chatswood, NSW	308.73	''	29/07/01
Mr Tony Dorevski, 9 Chaucer Street, Wetherill Park, NSW	309.19	''	17/07/97
Jag Miranda, Shop 2108, Westfield Shopping Town, The Kingsway, Miranda, NSW	309.20	''	13/02/01
Mr S. L. Djunaedi, 24 Barellan Avenue, Carlingford, NSW	309.41	''	05/08/95
Mr M. J. Kelly, Unit 8, Banora Palms, Darlington Drive, Banora Point, NSW	309.49	''	25/06/01
Mr J. P. Rooney, 31 Blundy Way, Littlehampton, SA	310.25	''	15/12/00
	310.27	''	26/06/01
	312.62	''	15/02/99
	312.67	''	02/03/96
	312.88	''	11/05/00

Mr Gary J Hutchinson, PO Box 130, Redcliffe, Qld	313.50	''	09/09/02
Ms Merryl Rothenbury, Settlers Landing, Villa 8, 4 Johnson Road, Maylands, WA	315.55	''	26/04/01
Mr Matthew Lobb, Telstra Corporation, 11/231 Elizabeth Street, Sydney, NSW	316.24	''	02/12/02
Shell Northgate, 346 Ingham Road, Garbutt, Townsville, Qld	319.04	''	28/11/01
Armada Shipping Pty Ltd, Attn Annette S. Miller, Suite 1, 36 The Esplanade, Brighton	320.68	''	24/09/95
Mr John A. Thomas, C/- Holden's Engine Company, 600 Lorimer Street, Port Melbourne	320.80	''	27/06/99
Mr John A. Alsop, 4 Paris Street, Balgowlah, NSW	320.83	''	31/10/98
Mr Steve Cooper, Lion Nathan Australia, 15/20 Hunter Street, Sydney, NSW	321.12	''	10/10/01
Mr M. J. Walder, 66 Kentwood Drive, Bray Park, Qld	321.22	''	06/05/00
Shell Jolimont, Corner of Hay Street & Jersey Street, Jolimont, WA	322.20	''	14/12/01
Mr J. Alexander, Castrol Australia, 132 McCredie Road, Guildford, NSW	324.75	''	14/02/96
Mr Minh N. Nguyen, 39 Doris Street, Picnic Point, NSW	325.94	''	10/10/01
Mr Jimmie Harris, Unit 18, 112-118 Talavera Road, North Ryde, NSW	326.10	''	13/08/96
Mr Paul L. Fraley, Level 20, 100 Miller Street, North Sydney, NSW	327.13	''	22/08/00
Newport Motors, Corner of Kalinya Street & Queens Park, Newport, NSW	327.56	''	23/05/01
Mr Scott E. Melville, 7 Trimmer Place, Canbah, ACT	327.64	''	20/10/99
Mr E. Stanton, 41 Greenacre Avenue, Lake Munmorah, NSW	329.88	''	06/04/96
Mr Michael E. W. Massey, Coles Myer Limited, Level 2, 246 Bourke Street, Melbourne	330.70	''	04/04/02
Mr Louis Dupe, Telstra Corporation, Level 15, 525 Collins Street, Melbourne	331.63	''	02/12/02
Ward Howell International, Journey's Unlimited, Attn Dennis Jones, GPO Box 208, Sydney, NSW	332.04	''	12/08/99
Miss Aliky Kouroupis, 4/144 Ocean Street, Narabeenm NSW	332.68	''	07/01/02
Woolford Jewellery, 1 Hirst Street, Jesmond, NSW	332.76	''	10/01/02
Mr Peter J. Madigan, Tandem Computers Pty Ltd, Level 6/76 Berry Street, North Sydney, NSW	333.65	''	03/12/97
Shell Cloverdale Self Services, Corner of Belmont Avenue & Wright Street, Cloverdale, WA	335.20	''	14/12/01
Mr Christopher W. Lees, Attn Joan Allan, PO Box 40, Sydney, NSW	335.27	''	21/03/01
Mr Robert B. Costello, Compair (Aust) Ltd, 17 Bareena Road, Tarooma, Tas.	336.80	''	09/06/96
Mr Steven J. Ober, Attn Lynne Holden, PO Box 1053, Spring Hill, Qld	337.79	''	29/08/02
Mr Michael J. Garbett, 26 Wollstonecraft Avenue, Avalon, NSW	338.00	''	06/09/01
Sydneyscope, Shop 103, Harbourside, Darling Harbour, NSW	338.33	''	02/04/02
Wyatt Gallagher Bassett, GPO Box 14, Brisbane, Qld	339.90	''	22/11/02
Casuarina Guns N. Tackle, Casuarina Shopping Centre, Trower Road, Casuarina, NT	341.00	''	19/12/01
Nader Petroleum, 651 Princes Highway, Rockdale, NSW	341.75	''	15/10/01
Mr David J. Gilbert, PO Box 95, Crafers, SA	346.72	''	08/04/01

Pioneer Road Services, Attn Dilys Bartholomeusz, PO Box 390, Melbourne	346.94	''	02/05/02
Jonties Cafe, 13 Commercial Street East, Mt Gambier, SA	347.85	''	24/04/02
Mr David J. Ferrall, Attn Nadine Smith, GPO Box Sydney 557, NSW	348.00	''	12/11/01
Mr Trevor C. Rowe, Salomon Smith Barney, Attn Stephanie Ceo, Level 16/225 George Street, Sydney, NSW	348.16	''	20/04/00
Mr Andrew Jarrett, IMR Worldwide, 7/10 Queens Road, Melbourne	349.22	''	03/12/00
Shell Roadhouse Carnarvon, North West Coastal Highway, Carnarvon, WA	352.12	''	18/09/01
Mr Mark J. Dickson, Saville Systems Australia, Level 9, 1 Elizabeth Plaza, North Sydney, NSW	352.54	''	31/05/99
Mr Peter C. Hughes, PO Box 288, Menai Central, NSW	354.00	''	18/09/02
Mr Gregory M. A. Williams, Tenix Defence Systems P/L, GPO Box 5113BB, Melbourne	356.29	''	18/06/01
Ms Penelope R. Boyce, 20 Elwood Street, Surrey Hills	357.79	''	24/12/02
Miss Hayley Squires, 3/23 Christie Street, St Leonards, NSW	358.78	''	11/12/00
Sovereign Motor Inn, 309 Maitland Road, Mayfield, NSW	359.67	''	01/10/02
The Estate of Dr J. Booth, 12A Coolibah Avenue, Kensington Gardens, SA	360.20	''	19/03/02
Jag Queen Victoria Bldg, Shop 10–12 Queen Victoria Bldg, 455 George Street, Sydney, NSW	361.70	''	26/06/01
Ms Nicola Milne, McDonald's Australia Ltd, Attn Account Support Group, PO Box 392, Pennant Hills, NSW	362.22	''	27/09/00
Inroads Fairfield, Unit 2, 2 Claremont Avenue, Greenacre, NSW	365.20	''	23/04/02
The Lobby Espresso Bar, 400 George Street, Sydney, NSW	366.18	''	08/06/01
Beach Culture, Ansett Terminal, Sydney Domestic Airport, Mascot, NSW	366.68	''	12/06/01
Mr Ron Westwood, Shell Co of Australia, GPO Box M934, Perth, WA	368.40	''	01/02/02
Shell Fremantle Self Serve, 101 Hampton Road, Fremantle, WA	368.61	''	14/12/01
Mr Mark J. Noakes, 13 Naranga Avenue, Engadine, NSW	371.21	''	30/08/00
Wilke Color, Attn Melinda Donovan, 37 Browns Road, Clayton	371.81	''	29/09/99
Mr Dennis J. Bright, Sampoerna Ji Rungkut Industries Raya No. 18 Surabaya 60293, Indonesia	372.55	''	13/02/02
Mr Laurence W. Davies, PO Box 8108, Wooloongabba, Qld	372.56	''	06/07/00
Franklins 011 Rose Bay, 5 Dover Road, Rose Bay, NSW	373.12	''	18/09/01
Mr Nicolas D. Leutwiler, 560 Church Street, Richmond	373.22	''	04/06/95
The Zoo Bar, 40 York Street, Sydney, NSW	374.04	''	12/11/01
Miss Chanpen Chanwanitwit, 5/307 Victoria Avenue, Chatswood, NSW	374.64	''	09/03/98
Ms Anne M. Birsa, Motorola House, Level 8/601 Pacific Highway, St Leonards, NSW	375.12	''	06/03/01
J. & R. Enigma Consulting, 1411/197 Castlereagh Street, Sydney, NSW	376.80	''	31/12/01
Mr Simon Crabtree, 1st Floor, Flat 120, High Road, East Finchley, London N2 9ED, United Kingdom	379.93	''	21/12/01
Mr Anthony C. Miller, PO Box 1455, East Malvern	380.83	''	09/04/02

Mr Nicholas J. Rimmer, 5/MTP 2550, 246 Bourke Street, Melbourne	380.96	”	12/02/02
Dr John R. Hunter, CSIRO Aust— Attn Pam Reid, GPO Box 1538, Hobart, Tas.	381.09	”	11/06/99
Rotary Club Maribryngong Highpoint, PO Box 168, Highpoint City	381.30	”	12/07/02
Mr Garry R. Morrison, The Salmat Group, 152 Miller Road, Chester Hill, NSW	384.10	”	27/07/99
Miss A. Wilmot, 15 Burton Street, Mosman, NSW	385.55	”	19/10/01
Mr Jacobus P. Barnard, Box 472, Edgecliff, NSW	387.49	”	29/04/99
Dr Susan J. Dann, PO Box 511, Virginia, Qld	387.70	”	07/06/02
A.F.D.A. (Funeral Directors), Attn Mr Bob Richardson, PO Box 291, Kew East	392.97	”	17/07/97
Mrs Margaret L. Judge, Simplot Australia, Private Bag 4, Flemington	393.90	”	15/02/02
Ampol Chullora, Corner of Hume Highway & Waterloo, Chullora, NSW	396.51	”	04/11/01
Ms Karen L. Noud, Coopers & Lybrand (Act) P/L GPO Box 150, Brisbane, Qld	396.84	”	10/05/99
Mr H. D. Calder, 28 Upper Watt Street, Wadestown, Wellington, New Zealand	398.47	”	07/05/98
Mr Martin Stuhldreher, IBM Global Services, 14/459 Collins Street, Melbourne	399.14	”	13/11/02
Jag, Shop 1068, Carindale S/C, Creek Road, Carindale, Qld	399.99	”	26/06/01
Mr Garry A. Denny, 1/6 Rheanva Street, Berwick	408.91	”	03/08/99
Mr Neil S. White, CSIRO Aust, Attn Maria Barrett, GPO Box 284, Canberra, ACT	410.94	”	24/12/99
Mr Terence T. Ho, 5/3 Hendy Avenue, Coogee, NSW	412.20	”	02/12/96
Mr Paul Brown, Boral Building Products, PO Box 571, Elizabeth, SA	412.80	”	17/12/01
Mr Jose-Luis Ilabaca, Consulate General of Chile, Level 18, 44 Market Street, Sydney, NSW	415.45	”	25/01/00
Mr M. A. White, 3 Austin Street, Wavell Heights, Qld	417.55	”	05/11/99
Pioneer Road Services, PO Box 390, World Trade Centre, Melbourne	418.92	”	02/05/02
Mr Fabian P. McKenna, PO Box 8117, Angelo Street, South Perth, WA	420.00	”	04/12/99
Gazelle Foods Pty Ltd, 25 Smith Street, Hillsdale, NSW	420.00	”	06/08/02
Ms Jacqueline K. Mein, PO Box 40596, Casuarina, NT	420.25	”	25/07/99
Mr D. Ablett, 215 Heatherhill Road, Frankston	421.09	”	11/10/02
Mr Paul R. Talay, C/- Leanne Brammer, Unit 33/7 Hale Street, North Ward, Qld	423.95	”	04/02/00
Mr F. R. Kent, 26 John Savage Crescent, West Pennant Hills, NSW	423.97	”	15/07/98
Mr A. Crivelli, Coffex Coffee P/L, 221 Moreland Road, Coburg	426.81	”	12/01/98
Mr Nigel Scott, Melwire Pty Ltd, PO Box 63 S.P.C. Welshpool, WA	428.48	”	01/07/97
Mr David Marko, 71 Wentworth Street, Randwick, NSW	438.80	”	08/10/98
Shell Kewdale, Corner of Abernethy & Kewdale Roads, Kewdale, WA	438.80	”	14/12/01
Pioneer Road Services, PO Box 390, World Trade Centre, Melbourne	441.98	”	02/05/02

Mr Stephen A. Trist, Norwich Union Navigator Ltd, GPO Box 2567W, Melbourne	443.74	”	20/03/02
Mr Samuel D. Wood, The Australian Workers Union, Suite 1, Level 3, 377–383 Sussex Street, Sydney, NSW	444.13	”	15/10/01
BP Bellbowrie, 3198 Moggill Road, Bellbowrie, Qld	447.50	”	04/09/01
Mr P. U. Ciavarra, Telstra, Locked Bag 4960, Melbourne	449.16	”	01/12/02
Mr Mathew Collett, C/- Diners Club Return Mail, PO Box 5088, Melbourne	449.25	”	01/07/02
Mr Oliver Rosenthal, 16 Bayside Crescent, Hampton	452.07	”	18/05/99
Mr Simon Lim, 8/269 Riley Street, Surry Hills, NSW	452.54	”	22/12/02
Shell Kewdale Trans Term, Corner of Kewdale Abernathy Road, Kewdale, WA	452.57	”	29/09/01
QBE Mercantile Mutual, Ms Lara Young, 85 Harrington Street, The Rocks, Sydney, NSW	454.92	”	31/10/02
Mr Rodney J. Allen, Telstra Corporation, 1/6 770 Blackburn Road, Clayton	458.51	”	25/03/00
Ms Bridget T. Quirk, Lion Nathan Australia, Locked Bag 14, Royal Exchange, NSW	459.68	”	08/11/00
Mr Reginald A. McNee, Tidewater Port, Jackson Marine, Private Bag 122, Abbotsford	460.58	”	05/02/97
Miss Yee M. Lau, 1st Floor, 70–76 Princes Highway, Arncliffe, NSW	460.72	”	29/07/98
Shell Service Dampier, Church Road, Dampier, WA	460.87	”	18/09/01
Shell Bicton Self Serve, 394 Canning Hwy, Bicton, WA	461.20	”	30/11/01
Mr David F. Fishwick, PPMA, 19/39–49 Martin Place, Sydney, NSW	462.90	”	25/05/99
Ms Kirstie N. Davidson, The Fourth Wave (Aust.) Pty Ltd, PO Box 78, Neutral Bay, NSW	464.28	”	18/04/97
Shell Smithfield, Cook Highway, Smithfield, Qld	466.18	”	28/11/01
Mr K. W. Barron, Human Synergistics Australia, 128 Kippax Street, Surry Hills, NSW	466.29	”	08/02/02
Mr John O’Meara, C/- Foursee, 3 Avon Road, North Ryde, NSW	467.13	”	29/04/02
Mr Andrew Green, Coles Supermarkets—NSW Office, 436–484 Victoria Road, Gladesville, NSW	471.85	”	19/11/99
Mr C. Pickering, Sedgwick Ltd, Attn Paul Robinson, GPO Box 1229L, Melbourne	472.27	”	30/05/97
Mobil, Corner Hillsborough & Macquarie Roads, Warners Bay, NSW	475.85	”	29/07/02
Mr J. C. Barnes, Sedgwick Ltd, Attn Paul Robinson, GPO Box 1229L, Melbourne	475.87	”	22/03/97
Mr John R. C. Gordon, Slater & Gordon, PO Box 1094, West Perth, WA	481.50	”	24/02/99
Mr Troy Suda, Myer 1025669 Loyalty Programme, 3/MTP 2504, 295 Lonsdale Street, Melbourne	484.13	”	08/08/00
Dr David J. Allardice, Attn Joanne Boldiston, 677 Springvale Road, Mulgrave	485.92	”	21/09/99
Mr Peter T. Black, 38 Vincent Street, Sandringham	487.17	”	23/10/97
Mr Martin B. Grubb, 1/6 Greville Street, Essendon North	491.36	”	30/05/00
Mr Peter J. Meehan, Sally Park, 1320 Malvern Road, Malvern	494.45	”	09/10/01
Mr Peter A. Manz, C/- Australian Defence Staff, Aust. High Commission, Locked Bag 129, Waigani, Port Moresby	494.45	”	03//12/02

Mr Masanao Asai, 3-39-7 Shimotakaido, Suginami-Ku 168-0073, Tokyo, Japan	495.00	''	22/03/01
Shell Leinster, Mainsbridge Road, Leinster, WA	496.92	''	28/09/01
Mr Grahame Booth, 5 Palmerston Crescent, Wheelers Hill	499.70	''	03/09/98
Mr John K. Durie, Melwire Pty Ltd, Private Bag 1, Rosebank MDC, Clayton	500.49	''	12/05/96
Mr Darren Schwedes, 17 Manchester Grove, Glenhuntly	505.65	''	07/10/02
Paul Beaumont Pty Ltd, 6/187 Macquarie Street, Sydney, NSW	507.48	''	04/12/02
Halliburton Aust.—Sale, Attn Marian Waugh, 62 Lygon Street, Carlton	508.30	''	06/03/97
Mrs Susi Nicklisch, Myer 1025560 Furniture, 4/MTP 2560, 295 Lonsdale Street, Melbourne	514.99	''	01/11/01
Mr Steve Marshall, Clayton UTZ, PO Box H3, Australia Square, Sydney, NSW	520.01	''	22/11/02
Mr John J. Harman, C/- Public Trustees Office, 565 Hay Street, Perth, WA	522.71	''	07/04/98
Mr Theng D. Teng, 22 The Ridge, Canterbury	529.09	''	18/07/00
Miss Julie A. Harrison, 3/2 Wetherill Street, Narrabeen NSW	531.04	''	04/06/01
Mr Richard J. Smith, Transfield Investments, Level 33, AMP Centre, 50 Bridge Street, Sydney, NSW	531.42	''	22/09/00
Mr Graham Kidner, Telstra Enterprise Services, GPO Box 9936, Adelaide, SA	531.69	''	18/06/02
Pioneer Road Services, PO Box 390, World Trade Centre, Melbourne	538.14	''	02/05/02
Mr Tom Manolakos, TPG Architects Pty Ltd, GPO Box 3769, Darwin, NT	544.05	''	10/03/99
Miss Catherine Lewis, C/- Prudential Portfolio Mgrs, Level 19, 39-49 Martin Place, Sydney, NSW	545.66	''	25/05/99
Mr William H. Garson Jr, Dyno Nobel Inc., 11th Floor, Crossroads Tower, Salt Lake City, Utah, USA	545.67	''	16/03/96
Mr Donald G. Martin, PO Box 537, South Windsor, NSW	547.43	''	07/05/95
National Convention Centre, Constitution Avenue, Canberra, NSW	549.65	''	18/06/01
BP Forest Glen, Mons Road, Forest Glen, Qld	549.67	''	27/11/01
Mr Stephen J. Williams, Big W, 3 City View Road, Pennant Hills, NSW	549.92	''	15/04/02
Mr D. I. Weste, Unit 7, 397 Murray Road, Preston	550.40	''	13/01/97
Mr Sanjay D. Samuel, 20 Dent Street, Glen Iris	551.73	''	22/04/98
Ms Helen J. O'Neil, News Limited, PO Box 100, Strawberry Hills, NSW	555.39	''	05/02/98
Mr Craig Maddison, Tidewater Port, Jackson Marine, 6/663 Victoria Street, Abbotsford	555.73	''	16/12/97
Mr Peter D. Barre, Coles Supermarkets, L4/M6, 800 Toorak Road, Tooronga	555.73	''	16/04/98
Miss Deborah C. Huber, IE Australia, 11 National Circuit, Barton, ACT	557.48	''	03/10/02
Mr Russ Beynon, John Holland Pty Ltd, PO Box 201, Toowong, Qld	561.90	''	22/07/02
Mrs Natasha Scott, 103/59-61 Ridge Street, North Sydney, NSW	565.51	''	22/10/02
Miss Tina M. Townsend, Lion Nathan Australia, 30/363 George Street, Sydney, NSW	566.54	''	05/11/01
Alexander & Alexander Ltd, PO Box 4157, Sydney, NSW	569.27	''	12/01/98

Ms Gemma Hogan, 105 Malop Street, Geelong	576.52	''	25/03/02
Margot Pickering, Canon Australia Pty Ltd, PO Box 313, North Ryde, NSW	577.62	''	11/04/02
Ms Sonya Szell, KPMG Management Consulting, 161 Collins Street, Melbourne	579.75	''	07/09/99
Mr Peter Fisher, Collection, RMG	582.35	''	23/07/93
Mr Anthony L. Crouch, C/- Hawker De Havilland Vic., GPO Box 779, Melbourne	583.30	''	12/12/00
Mr Timothy L. Congelliere, C/- Hawker De Havilland Vic., GPO Box 779H, Melbourne	583.30	''	12/12/00
Shell Karratha Truck, North West Coastal Highway, Karratha, WA	589.45	''	14/12/01
Mr Paul V. Taylor, 16 Lisbon Court, Parkwood, WA	593.36	''	23/11/98
Prof Andrew G. Ostor, 48 Anderson Road, Hawthorn East	594.35	''	09/07/01
Miss Melanie E. Hardman, 12/7 Wylde Street, Potts Point, NSW	600.00	''	17/10/00
Ms Sharon M. Cheah, The Old Forge—Ashford, Ballynahinch, County Wicklow, Ireland	600.82	''	27/02/99
Mr James Thorpe, 6 Evelyn Avenue, Turramurra, NSW	601.38	''	24/05/99
Ms Catherine D. Leahy, KPMG, GPO Box 2291U, Melbourne	607.56	''	29/11/00
Mr P. Robinson, 21 Ash Grove, Malvern East	614.11	''	25/11/02
Pica Group Limited, Attn Mr. A. G. Taylor, Level 34/385 Bourke Street, Melbourne	614.37	''	14/01/00
Ms Alexandra Cannon, Castlemaine Perkins, GPO Box 44, Brisbane, Qld	615.37	''	22/01/99
Mr Reginald A. McNee, Attn Jane Marr, Tidewater Port Jackson, PO Box 6007, West Perth, WA	617.53	''	01/10/98
Ms Jean L McCullough, Pacific Star Communications, Level 11/179 Elizabeth Street, Sydney, NSW	621.51	''	10/08/96
Mr Martin McGuinness, 120 Virgilia Drive, Hoppers Crossing	624.36	''	29/08/01
Fisher & Paykel Glenroy, 32 Wheatsheaf Road, Glenroy	638.74	''	16/01/02
Mr Rick Jackson, NRMA, Attn Jan Scott, 26/388 George Street, Sydney, NSW	639.02	''	11/02/02
JDR Automotive, 154 Creek Road, Mount Gravatt, Qld	639.52	''	04/01/02
Mr G. Russo, Level 10, 1 Collins Street, Melbourne	640.11	''	19/12/96
Lion Nathan Aust Pty Ltd, Locked Bag 14, Royal Exchange, Sydney, NSW	643.87	''	19/12/02
Mr Douglas R. Hindson, Kinnears Pty Ltd, PO Box 162, Footscray	645.39	''	28/09/98
Mr Stephen Robertson, Attn Maureen Ellis, Level 16/120 Collins Street, Melbourne	645.74	''	03/09/02
Ronald J. C. Dark, C/- Diners Club Return Mail, GPO Box 5088, Melbourne	647.85	''	10/12/02
Mr Paul E. Prass, Attn Jan Scott, Level 26, 388 George Street, Sydney, NSW	652.39	''	13/01/99
Mr John Raams, 3 Rolls Court, Happy Valley, SA	652.51	''	23/07/98
Mr Geoffrey R. Hamblin, Containers Cartons, PO Box 105, Belfield, NSW	652.86	''	18/08/96
Mrs Amanda J. Williams, PO Box 453, Parkholme, SA	655.20	''	19/12/02
Mr Robert J. McKenzie, Locked Bag 14, Royal Exchange, NSW	657.98	''	05/11/01
Mr Klaus Anton, 31 Wooddale Grove, Mitcham	659.28	''	17/03/99

Siemens Process Instrument, PO Box 339, South Melbourne	660.00	''	15/11/01
Mr Colin Samson, Cadbury Confectionery Group, PO Box 6159, Acacia Ridge, Qld	660.40	''	02/06/01
Tech Pacific Australia, Private Bag 20, Rosebery, NSW	662.08	''	15/04/02
Mr R. W. Woodbridge, QBE Insurance, Level 16, 100 Edward Street, Brisbane, Qld	666.93	''	10/04/00
Bailey Road Discount Fuel, 165 Bailey Road, Deception Bay, Qld	669.81	''	26/04/02
Mr Trevor J. Tucker, Mglieri Wines RSD, 295 Douglas Gully Road, McLaren Flat, SA	676.27	''	26/02/02
Mr Tim Shaw, The Shell Co. Australia, GPO Box 872K, Melbourne	680.40	''	21/08/02
Mr John Houston, 14 Wall Avenue, Panania, NSW	686.69	''	12/12/02
Mr Neil A. Behrens, 64 Nicholson Street, Fitzroy	688.69	''	29/04/99
Mr Keith Berry, Telstra Corporation, Locked Bag 3684, Brisbane, Qld	691.63	''	02/12/02
Mr David J. Bull, 6 Dodson Crescent, Winston Hills, NSW	693.15	''	19/02/02
Mr Jochen Bonitz, C/- Ansett Australia, Level 9/501 Swanston Street, Melbourne	694.42	''	10/04/02
Mr Robert D. McKerrow, Thiess Pty Ltd, Locked Bag 2009, South Brisbane, Qld	696.14	''	01/05/02
Mr Ian A. Bertram, C/- Diners Club, Return Mail, NSW	697.72	''	23/10/98
Mr Christopher J. Hatcher, Mildura Blass Ltd, 21 College Street, Tanunda, SA	700.55	''	26/02/02
Mobile Choice, Shop 3/134 The Parade, Norwood, SA	709.58	''	02/03/02
Bob Jane T. Mart, corner of Hume Hwy & Townsend Street, Albury, NSW	711.31	''	29/04/02
Mr Garry Graham, Myer 1025550 Leisure, 5/MTP 2550, 295 Lonsdale Street, Melbourne	715.07	''	01/11/01
Mr Christopher J. Forbes, Du Pont (Australia) Ltd, PO Box 930, North Sydney, NSW	716.83	''	18/09/97
Mr A. Vidoni, PO Box 167, Welshpool, WA	717.71	''	04/10/02
Mr Adrian Ciccotosto, Shell Australia Company Ltd, GPO Box M 934, Perth, WA	719.06	''	08/01/02
Advantage Petroleum-Bala, Old Hume Hwy, Mittagong, NSW	719.42	''	31/05/01
Ms Dawn King, 1 Berkeley Grove, Brighton East	719.59	''	01/04/00
Mr Gregory R. Davis, Thiess Pty Ltd, Locked Bag 2009, Brisbane South, Qld	720.28	''	18/01/02
Advantage Petroleum-Sutton, Hume Hwy, Sutton Forest, NSW	722.37	''	04/06/01
Mr Glenn W. Wheatland, Dairy Vale Foods Ltd, PO Box 121, Edwards Town, SA	729.44	''	09/07/98
Mr Matthew Coulson, 17 Welwyn Avenue, Brighton East	731.80	''	04/05/01
Frattini, 122 Marion Street, Leichhardt, NSW	732.28	''	12/03/02
CNH Australia Pty Ltd, 31/67 Kurrajong Road, St Marys, NSW	732.42	''	10/06/02
Mrs N. A. Bessell-Brown, 157 Rochdale Road, Mount Claremont, WA	734.00	''	09/10/00
Mr Keith B. Bashford, CSIRI Aust., Attn Ms L. Farnell, GPO Box 1538, Hobart, Tas	734.54	''	08/10/97
Kellys, 521 Stanley Street, Woolloongabba, Qld	739.27	''	02/10/01
Sedgwick Ltd, Attn Sarah Taylor, GPO Box 1229L, Melbourne	739.57	''	24/09/97
Ms Karen J. Pickering, AE Conventions Pty Ltd, PO Box G181 Queen, Vic. Terrace, Canberra, ACT	744.77	''	30/10/95

Mr David Mylius, Tidewater Port Jackson Marine, Private Bag 122, Abbotsford	744.83	''	18/03/97
Mr Jeffery M. Hall, M. S. Industries Pty Ltd, PO Box 232, Midland, WA	745.20	''	14/12/00
Mobil Surfers Paradise, 100 Ferny Avenue, Surfers Paradise, Qld	746.33	''	16/07/01
Hye Won, 1 Kellette Way, Kings Cross, NSW	748.08	''	27/09/01
Mr Graham J. Correy, 5 Mildred Ave, Manly Vale, NSW	750.06	''	30/04/99
Mr Noel T. McAuliffe, Ewl Sciences Pty Ltd, PO Box 39443, Winnellie, NT	755.49	''	02/12/00
Flying Stone Port Douglas, Shop 2, Calypso Plaza, Corner of Shield Street–Esplanade, Cairns, Qld	759.32	''	13/07/01
Mr David Mylius, Tidewater Port Jackson Marine, PO Box 122, Abbotsford	777.47	''	18/03/97
Mr Roger M. Blachut, Attn Ian Duncan, LH/M6 800 Tooronga Road, Tooronga	778.16	''	20/04/96
Castrol Optilube Admin–NSW, Optilube, 2 Chiswick Road, Auburn, NSW	779.87	''	17/06/96
Mr Dugald McWilliams, 19/55 Market Street, Sydney, NSW	799.06	''	04/06/98
Mr Gavin A. Abbott, #2 Mini House, 5–17 Itaewon-Dong/Yongsan-Gu, Seoul 140–202 South Korea	825.67	''	04/12/02
Mr Peter A. Noone, Berkley Fenwick Aust Pty Ltd, Malaga, WA	829.50	''	03/09/95
Mr Geoff Squires, 71 Remington Drive, Highland Village, Texas 75077, USA	835.99	''	12/03/01
Miss Thricia Goves, Results Accountants, PO Box 306, Roma Street, Qld	838.84	''	28/10/98
Shell Claremont, 269 Stirling Highway, Claremont, WA	842.13	''	14/12/01
BZW–Corporate Finance, Attn Debbie Bennett Accounts, BZW Australia Ltd, GPO Box 4675, Sydney, NSW	858.14	''	28/01/97
Miss Lynne Walker, 38 Maltings Close, Alton, Hampshire GU341DT, United Kingdom	860.32	''	30/11/99
Mr Michael Blinco, Associated Water Equipment PL, PO Box 1300, Eagle Farm, Qld	864.88	''	19/03/98
Mr Ross J. Magee, IBM, Corner of Sussex & Market Streets, Sydney, NSW	870.79	''	02/08/00
Mr Geoffrey C. Hosking, Berri Ltd, PO Box 301, East Melbourne	879.53	''	03/09/98
Mr Peter Walden, 15/201 Kent Street, Sydney, NSW	887.53	''	25/05/99
Liberty Liquor 15, 9 Short Street (Lot 50), Broome, WA	894.89	''	26/06/01
Margot Pickering, Canon Australia Pty Ltd, PO Box 313, North Ryde, NSW	904.02	''	11/04/02
Mr D. Dempster-Smith, 5 Hinkler Street, Greenwick, NSW	909.94	''	19/11/95
Mr Gareth H. Cope, Attn Joan Allan, PO Box 40, Sydney, NSW	910.16	''	18/07/01
Be Tempted Agency, 568 Railway Parade, Hurstville, NSW	917.83	''	20/05/02
Shell Bullcreek Self Serve, Corner of Benningfield Road, & Leichardt Street, Bull Creek, WA	923.44	''	30/11/01
Armstrongs Bar Restaurant, Shop 213, Manly Wharf, Manly, NSW	932.46	''	01/08/01
PA Corp—Test Account 1, Attn Shareen Dayal, Accts Payable, 181–189 Victoria Parade, Collingwood	937.94	''	31/12/02

Mr Graham R. Stuart, 3 Victoria Avenue, Chatswood, NSW	942.04	''	09/09/99
Private Health Services P/L, Attn Mr Peter Freeleagus, 36 Palm Avenue, Ascot, Qld	942.18	''	02/08/02
Ms Nicole G. Sievert, Pepsi Co., 27 Huntingwood Drive, Huntingwood, NSW	945.65	''	20/11/00
Mr Graham S. Patton, 9/19 Redmyre Road, Strathfield, NSW	945.75	''	11/05/99
Mr P. D. Evans, Freehills Accounts Dept, GPO Box U1942, Perth, WA	965.19	''	30/08/02
Mr Maurice Byok, 101 Victoria Avenue, Chatswood, NSW	967.31	''	12/02/02
Wyatt Gallagher Bassett PL, PO Box 14, Brisbane, Qld	989.35	''	04/12/02
Mr Jon K. Sturgess, 5 Snowden Place, Wantirna South	991.03	''	20/01/00
Mr Kerry G. Parkin, Suite 8/8 Phipps Close, Deakin, ACT	996.69	''	08/10/02,
Mr R. W. McFarlane, PO Box 270, Archerfield, Qld	1,000.00	''	21/12/01
Mr Alexander S. Crossley, 95 Chandof Street, Crows Nest, NSW	1,027.44	''	21/06/96
Charles Casuarina Restaurant, No 8, 1st Floor, Little Street, Forster, NSW	1,028.21	''	20/01/02
Mr Chris L. Barnes, 98 Gurrang Avenue, Ngunnawal, ACT	1,033.99	''	31/01/01
Mrs Julie Phillips, Coloplast, 88 Logan Road, Woolloongabba, Qld	1,038.87	''	17/08/96
Mr Ronald D. Clark, Attn Jan Scott, Level 26, 388 George Street, Sydney, NSW	1,048.97	''	16/11/01
Mr Richard S. Duerden, Goodman Cannington Prince, 23-31 Gheringham Street, Geelong	1,052.55	''	27/12/00
Mr Garry B. Shaw, PO Box 12, South Hobart, Tas.	1,055.52	''	06/09/00
Mr Sean M. Vaughan, Attn Stephanie Ceo, Level 16/225 George Street, Sydney, NSW	1,062.79	''	28/08/01
Mr Jeffrey M. Keech, C/- 74 Charlotte Street, Aitkenvale, Qld	1,063.42	''	06/01/99
Mr Hiroshi Ishihara, Nippon Oil Australia, Level 27, 2 Chifley Square, Sydney, NSW	1,070.32	''	05/04/02
TDG Distribution Pty Ltd, Attn Ilona Schilen, PO Box 4019, Glenway MDC	1,079.50	''	10/05/00
Advantage Petroleum—Bowr, PO Box 770, Fyshwick, NSW	1,083.25	''	28/05/01
Mr Eckhard Kemmerer, Sanitarium Health Food Co., Locked Bag 7, Central Coast Mail Centre, NSW	1,089.86	''	13/10/99
Mr Paul J. Miller, Campbell Cleantec, PO Box 490, Sumner Park BC, Qld	1,157.06	''	18/06/02
Mr Alan S. Markham, Attn Jrhiannon Martin, 677 Springvale Road, Mulgrave	1,158.81	''	22/08/02
Mr James Gough, Locked Bag 14, Royal Exchange, Sydney, NSW	1,158.91	''	02/11/01
Dr Ian Bartlett, PO Box 128, Crows Nest, NSW	1,158.96	''	13/12/01
Mr Gary A. Scott, 11 Krueger Street, Baranduda	1,171.23	''	26/07/01
Mr Richard Bridgman, PO Box 515, Balcatta, WA	1,171.77	''	01/12/98
Ms Justine Siegel, Compuware Asia-Pacific P/L, Level 16/607 Bourke Street, Melbourne	1,176.11	''	01/02/01
Snow Bunny Ski Lodge, PO Box 552, Jindabyne, NSW	1,177.27	''	06/09/01
Miss Kari E. Pitkin, Attn Joan Allan, Level 16, 225 George Street, Sydney, NSW	1,203.64	''	12/12/00
Mr Edward J. Gregory, 180 Bank Street, South Melbourne	1,205.48	''	10/11/01
Mr K. Hamish MacGowan, C/- Diners Club Return Mail, PO Box 5088, Melbourne	1,224.54	''	05/08/02

Mr Barry Grisdale, Telstra Enterprise Services, Level 4, 201 Sussex Street, Sydney, NSW	1,232.88	''	26/06/02
Mr Gareth Jones, OAMPS Insurance Brokers Ltd, PO Box 542, Kewotsford	1,234.86	''	13/06/01
Shell West Perth Auto Care, Corner of Thomas & Wellington Streets, West Perth, WA	1,257.79	''	04/12/01
Mr R. J. Heterick, PO Box Q993, Queen Victoria Post Office, Sydney, NSW	1,264.28	''	02/04/01
Dr C. G. McLoughlin, 508 Anzac Parade, Kingsford, NSW	1,277.06	''	29/11/02
Ms Kerry K. O'Regan, 16 Fulton Crescent, Burwood	1,316.17	''	13/02/98
Mrs E. Dangar, C/- Diners Club Intl, 1193 Toorak Road, Hartwell	1,325.91	''	30/08/02
Mr James A. Gordon, Price Waterhouse, 215 Spring Street, Melbourne	1,360.82	''	03/05/99
Miss Emmaline L. Fairthorne, Kmart Australia, 800 Toorak Road, Tooronga	1,361.63	''	26/09/02
Mr Colin G. Partington, Thiess Pty Ltd, Level 5, 40 McDougall Street, Milton, Qld	1,365.15	''	01/05/02
Mr Charles H. Humphrey, Level 26, 580 George Street, Sydney NSW	1,369.82	''	19/01/99
Miss J. R. Firkin, Clayton UTZ, Level 28/No. 1 O'Connell Street, Sydney, NSW	1,393.40	''	20/05/02
Mr Raymond I. Walker Tandem, 147 Cross Road, Alamo, California 94507, USA	1,407.22	''	08/03/00
Woodhead International P/L, Attn John Wenzel, 26 Chesser Street, Adelaide, SA	1,424.25	''	31/08/99
Ms Bridget Powell, NRMA, Attn Jan Scott, 26/388 George Street, Sydney, NSW	1,438.51	''	16/11/01
Ms Hema Mani, 6 Way Street, Kingsgrove, NSW	1,454.27	''	06/08/98
Nylec Products Pty Ltd, PO Box 312, Bayswater	1,455.30	''	04/12/02
Mr Kerry J. Duggan, Hunter Control Pty Ltd, PO Box 516, Mayfield, NSW	1,456.85	''	22/11/02
George Keskerides Pharmacy, 1160 Nepean Highway, Cheltenham	1,487.68	''	04/12/02
Shell West Perth, Corner of Thomas Street & Wellington Streets, West Perth, WA	1,496.76	''	10/12/01
Vysarn Pty Ltd, PO Box 174, Melville, WA	1,498.20	''	09/07/98
Mr Mark Thomy, Castrol Australia P/L, 13th Floor, ADC House, 189 Kent Street, Sydney, NSW	1,504.72	''	27/02/96
Neil Grigg Millinery, 123 Manning Road, Woollahra, NSW	1,510.54	''	22/10/01
Ms Tanya V. Walters, 5 Phoebe Street, Balmain, NSW	1,513.66	''	04/01/00
Mr Richard M. Parish, Tidewater Port Jackson, 6/ 663 Victoria Street, Abbotsford	1,556.66	''	03/02/97
Mr Stephen Murray, C/- Diners Club Return Mail, PO Box 5088, Melbourne	1,568.13	''	11/11/02
Mr Peter F. Campbell, 18 Prospect Terrace, Highgate Hill, Qld	1,570.38	''	05/02/97
Mr Mark F. Gerus, 138 Eight Avenue, Maylands, WA	1,571.79	''	05/11/02
Die Rule Supply Co. Ltd, 50 Kolora Road, West Heidelberg	1,587.35	''	04/12/02
Allen Jack & Cottier, Attn Alban Yuen, 59 Buckingham Street, Surry Hills, NSW	1,598.23	''	31/12/97

Miss Melanie Forbes, Coles Myer Limited, Level 2, 246 Bourke Street, Melbourne	1,609.63	”	05/04/02
Mrs Lynette Innes, Goudriaanstraat 16, 1222 SG Hiversum, The Netherlands	1,611.26	”	05/04/02
Mr Alan Mehrten, C/- Hayes International, PO Box 3377, Robina Town Centre, Robina, Qld	1,617.66	”	11/08/00
Palm Centre Pharmacy, Palm Centre, Coffs City Mall, Coffs Harbour, NSW	1,640.69	”	30/01/02
Dr Alan J. Parsley, Shell Development (Aust) P/L, L28, QVL Bldg, 250 St Georges Terrace, Perth, WA	1,651.62	”	17/09/02
Mr Paul Raftery, 14 Houghton Street, Red Hill, Qld	1,684.51	”	03/04/01
Swarovski Shop, Shop 1, Westfield Shopping Town, West Lakes, SA	1,711.96	”	10/01/02
Mr Eric W. Clapp, Attn Penny Alcock, GPO Box 557, Sydney, NSW	1,761.98	”	24/09/01
Mr Michael D. Hamer, 11 Bodrum Crescent, Mindarie, WA	1,764.19	”	01/11/02
Ms Sue E. Wilson, CSIRO Australia, 723 Swanston Street, Carlton	1,780.14	”	07/10/97
Mr Elio Franco, 1 Clydesdale Court, Athelstone, SA	1,808.16	”	06/07/01
Cognos Pty Ltd, Level 3, 110 Pacific Highway, St Leonards NSW	1,840.00	”	11/10/00
BZW—Administration, Attn Debbie Bennett, Accounts, BZW Australia Ltd, GPO Box 4675, Sydney, NSW	1,894.22	”	26/02/97
S.V.P.H. Health Assessment, Patient Accounts, Locked Bag 5, Darlinghurst, NSW	1,911.83	”	17/04/02
Mr Paul W. Lindstrom, C/- Coopers & Lybrand, GPO Box 150, Brisbane, Qld	1,911.98	”	13/09/97
Knox Case Place, 5 Stafford Street, Midland, WA	1,919.53	”	13/07/01
South Gundagai Truck, Hume Highway, Gundagai, NSW	1,965.36	”	06/06/01
Miss Michelle S. Hullett, Freehills Accounts Dept, GPO Box U1942, Perth, WA	1,998.31	”	30/08/02
Mrs Maria Butler, Attn Jan Scott, Level 26, 388 George Street, Sydney, NSW	2,029.72	”	16/11/01
Mr Christopher P. Jones, Alesco Corporation Ltd, PO Box 304, Cloverdale, WA	2,040.29	”	23/06/01
St George Commercial Bank, Attn Belinda Hui, Level 12/182 George Street, Sydney, NSW	2,122.28	”	08/11/00
Del Vecchio's Restaurant, 32 Flushcombe Road, Blacktown, NSW	2,147.88	”	22/11/01
Mr John W. Cook, Gas Corporation of Qld Ltd, GPO Box 484, Brisbane, Qld	2,174.64	”	27/09/97
Mr Philippe Odouard, Thomson Sintra Pacific, PO Box 326, North Ryde, NSW	2,177.01	”	13/08/96
Miss Michelle Lock, 9 Ibsley Square, Eltham	2,199.84	”	07/07/99
Miss Lisa M. Nash, 19/4 Stokes Street, Lane Cove, NSW	2,206.64	”	15/01/97
Miss Alison J. Badger, 5A/201 Kent Street, Sydney, NSW	2,211.06	”	22/04/99
Mr Grant R. White, 94 Sixth Avenue, Bardonia, Qld	2,275.49	”	09/10/01
Conoflex Packaging, Attn Shirley Holland, PO Box 77, Preston	2,289.05	”	12/01/97
Mr John Davis, Private Bag 10, Sth Eastern Mail Centre	2,297.04	”	27/05/98
Dr Surjit S. Rana, C/- Diners Club Return Mail, PO Box 5088, Melbourne	2,328.97	”	29/07/02

Miss Marie L. Bulzomi, 402/318 Harris Street, Pyrmont, NSW	2,362.71	”	31/12/97
A. Gregory Associates, 23 Zaara Street, Newcastle, NSW	2,494.16	”	04/07/01
Mr Phil Preston, 102 Otford Road, Otford, NSW	2,542.46	”	18/06/99
Mr K. W. Catlow, Attn K. Prestney, Accounts Dept, PO Box 758, Hawthorn	2,558.73	”	14/01/99
Mr Paul Blackman, 55 Keane Street, Peppermint Grove, WA	2,562.19	”	25/07/02
Mr Scott A. Lowther, Attn Susan Fogarty/Deloittes, Level 9, 473 Bourke Street, Melbourne	2,576.40	”	03/08/01
Mr D. Renshaw, 6 Kelly Road, South Cranbourne	2,749.26	”	13/07/99
Mr Matthew G. R. Taylor, 20 High Street, Haslingfield, Cambs CB3 7JW, UK	2,768.00	”	30/08/00
Mr Arnaud Labreze, GPO/PO Box 910, Sydney, NSW	2,768.40	”	18/02/99
Bremers Service Station, 77 Church Street, Mudgee, NSW	3,002.78	”	10/07/01
Mr Alistair Shaw, PO Box 563, Roma, Qld	3,004.87	”	05/11/01
Mr Richard M. Parish, Tidewater, Port Jackson, 6/663 Victoria Street, Abbotsford	3,013.98	”	11/12/96
Mr Paul L. Treverton, 97 Spring Street, Melbourne	3,204.40	”	08/02/99
Treasury Control Pty Ltd, Attn Mr Peter McLean, Level 10/499 St Kilda Road, Melbourne	3,263.76	”	11/06/95
Caribbean Gardens P/L, Ferntree Gully Road, Scoresby	3,274.85	”	04/12/02
Mr Michael A. Peters, Attn Jan Scott, Level 26, 388 George Street, Sydney, NSW	3,288.18	”	16/11/01
Mr David A. Hood, Institution of Engineers, 11 National Circuit, Barton, ACT	3,393.70	”	10/10/00
Ms Sandra N. Feletti, Deloitte & Touche Consulting, PO Box N250, Sydney, NSW	3,617.42	”	13/03/00
Mr David R. Mackay, 5 Deborah Place, Annangrove, NSW	4,172.68	”	20/06/00
Ms Stephanie Radcliff, 46 Bower Street, Manly, NSW	4,223.85	”	15/06/01
Miss Katherine Oliver, NCR Australia, 8–20 Napier Street, North Sydney, NSW	4,274.73	”	03/09/02
Mr Marimuthu Palaniswami, Blk 914, Jurong West Street, 91 #06-216 Singapore	4,337.37	”	08/07/99
Mr Peter St George, Attn Glenise Anderson, GPO Box 557, Sydney, NSW	4,753.08	”	04/07/01
Mr Stuart A. Dreves, Deloitte Touche Tohmatsu, Level 5/225 George Street, Sydney, NSW	6,323.14	”	02/07/02
Deloitte Touche, Trowbridge Consulting Ltd, Level 39, 140 William Street, Melbourne	6,737.70	”	05/06/02
Salomon Brothers Aust Ltd, Level 26/9 Castlereagh Street, Sydney, NSW	7,860.05	”	30/01/98
Internet Name Group, 1/222 St Kilda Road, St Kilda	9,319.63	”	09/08/02
Gordon R. Campbell Pty Ltd, PO Box 393, Wahroonga, NSW	15,489.03	”	14/04/01
Mrs Marie C. Zundel, Colonial Mutual Life Assurance, 14th Floor, 330 Collins Street, Melbourne	28,457.86	”	17/06/00

04017

CONTACT: KATHRYN MARCUS (03) 9805 4444.

Unclaimed Moneys Act 1962

Register of Unclaimed Moneys held by the —

<i>Name of Owner on Books and Last Known Address</i>	<i>Total Amount Due to Owner</i>	<i>Description Of Unclaimed Money</i>	<i>Date when Amount first became Payable</i>
MADGWICKS			
	\$		
Brightstar Information Technology Inc., C/- Mr Donald W. Rowley, 950 Tower Lane, Suite 1850, Foster City, California, USA	753.96	Cheque	27/10/00
03286 CONTACT: RHIANNON JONES, PHONE: (03) 9242 4743.			

Unclaimed Moneys Act 1962

Register of Unclaimed Moneys held by the —

<i>Name of Owner on Books and Last Known Address</i>	<i>Total Amount Due to Owner</i>	<i>Description Of Unclaimed Money</i>	<i>Date when Amount first became Payable</i>
PRO MEDICUS LIMITED			
	\$		
Mr Leon Unglik, 51 Somers Avenue, Malvern	150.00	Cheque	21/10/02
04022 CONTACT: ASX PERPETUAL REGISTRARS CUSTOMER SERVICE, PHONE: 1300 554 474, (03) 9615 9999.			

Unclaimed Moneys Act 1962

Register of Unclaimed Moneys held by the —

<i>Name of Owner on Books and Last Known Address</i>	<i>Total Amount Due to Owner</i>	<i>Description Of Unclaimed Money</i>	<i>Date when Amount first became Payable</i>
YARRA VALLEY WATER LTD			
	\$		
Mr D. Naylor, 5 Blyton Court, Templestowe	100.80	Cheque	01/02/02
Ms E. J. Alexander, 233 Victoria Road, Northcote	102.55	"	05/09/02
Mrs K. D. Wendt, 5 Crossman Drive, Croydon Hills	103.60	"	29/05/97
Mr R. W. M. Brown, 8 Halifax Street, Box Hill North	104.10	"	14/11/02

Megatron Electronic Industries Pty Ltd, 46–54 Centre Way, Croydon	105.41	”	08/04/03
Mrs L. G. Green, 96 Dundas Street, Thornbury	106.90	”	28/08/02
Mr L. McFarlane, Unit 4, 9 Egginton Street, Brunswick West	108.45	”	12/06/02
Mr B. Galati, 52 Dandallo Drive, Eltham	110.14	”	04/07/02
Ms E. Sutherland, 26 Riverside Drive, Warburton	110.80	”	23/10/02
Mr C. H. Cheng & Mrs S. W. Cheung, 27 Pelham Drive, Vermont	112.45	”	28/10/02
Estate of Mrs I. V. Lawrie, 1 Edgecombe Street, Kew	118.70	”	02/04/01
Mr S. Cook, 1191 Dandenong Road, Malvern East	119.95	”	30/05/02
Australian Gas Products, 489 High Street, Northcote	121.90	”	18/06/99
Mr L. & Mrs M. Parker, 109A Pearson Street, Brunswick West	125.85	”	30/12/02
Mr S. Bover Groen & Ms E. Maleckas, 314 Maroondah Highway, Healesville	127.30	”	17/04/02
Mr R. Rivett, Unit 4, 10 Macartney Street, Reservoir	130.60	”	30/10/02
Ms R. E. Spicer, 9 Warwick Road, Greensborough	139.40	”	27/03/02
Mr D. N. Sibel, Unit 4, 203 Station Street, Fairfield	140.63	”	31/10/02
Mr V. E. Woolf, 38 Cecil Street, Kew	141.55	”	15/11/02
Mr G. & Mrs J. Reed, 6 Beatrice Court, Blackburn	142.00	”	26/03/02
Ms Y. Zhao & Mr X. Tang, 34 The Crest, Bulleen	144.75	”	20/12/02
Mr & Mrs D. Shenck, 114 Gordon Street, Balwyn	145.75	”	26/08/02
Ms C. J. Williams, 23 Carlisle Street, Preston	148.10	”	22/08/02
Mrs T. A. Bleumink, 171 Cambridge Road, Mooroolbark	148.34	”	30/05/02
Mr D. E. H. & Mrs M. P. Hansen, 9 Coram Court, Coolaroo	151.80	”	06/11/02
Ms Y. M. Rodgers, 11 Forster Street, Heidelberg West	160.00	”	20/12/02
Quaver Software Pty Ltd, 56 Manningtree Road, Hawthorn	165.65	”	20/11/02
Mr B. Begovic, 3 Dana Court, Mulgrave	189.62	”	26/02/02
Mrs A. E. Poon, 6 Panorama Avenue, Ringwood	209.55	”	15/03/02
Ms L. Hale, 8 Mannagum Walk, South Morang	218.95	”	07/05/02
Culnair Developments Pty Ltd, Flat 3, 2 Raynes Street, Balwyn	250.36	”	13/05/02
Ms L. Barrett, Flat 3, 14 Osborne Avenue, Glen Iris	260.35	”	06/08/02
Mr A. & Mrs O. El-Rafel, 3 Shaba Court, Meadow Heights	321.51	”	04/04/02
Mr P. Vecci, 320 Manningham Road, Doncaster	404.10	”	26/10/02

04034

CONTACT: JANE CUMMING. PHONE: (03) 9872 1210

PROCLAMATIONS

ACTS OF PARLIAMENT

Proclamation

I, John Landy, Governor of Victoria, declare that I have today assented in Her Majesty's name to the following Bill:

No. 1/2004 **Nurses (Amendment) Act 2004**

Given under my hand and the seal of Victoria at Melbourne on 6 April 2004.

(L.S.) JOHN LANDY
Governor
By His Excellency's Command

STEVE BRACKS MP
Premier

No. 1/2004 **Nurses (Amendment) Act 2004**

This Act comes into operation on the day after the day on which it receives the Royal Assent.

Fisheries (Further Amendment) Act 2003

PROCLAMATION OF COMMENCEMENT

I, John Landy, Governor of Victoria, with the advice of the Executive Council and under section 2(2) of the **Fisheries (Further Amendment) Act 2003** fix 8 April 2004 as the day on which section 5 of that Act comes into operation.

Given under my hand and the seal of Victoria on 6th day of April 2004

(L.S.) JOHN LANDY
Governor
By His Excellency's Command

BOB CAMERON
Minister for Agriculture

**GOVERNMENT AND OUTER BUDGET
SECTOR AGENCIES NOTICES**



**MORNINGTON
PENINSULA**
Shire Council

**DISCONTINUANCE OF LANE AT REAR OF
11 DOUGLAS STREET, HASTINGS**

Pursuant to Section 206 and Schedule 10, Clause 3 of the **Local Government Act 1989**, the Mornington Peninsula Shire Council has formed the opinion that the section of lane at the rear of 11 Douglas Street, Hastings, as shown hatched on the plan below, is not reasonably required as a road for public use, Council has resolved to sell the land from the road to the adjoining owner by private treaty.

The land is subject to any right, power or interest held by the Mornington Peninsula Shire Council and South East Water Limited in connection with any sewers, drains, pipes, wires or plant under the control of these authorities in or near the road.

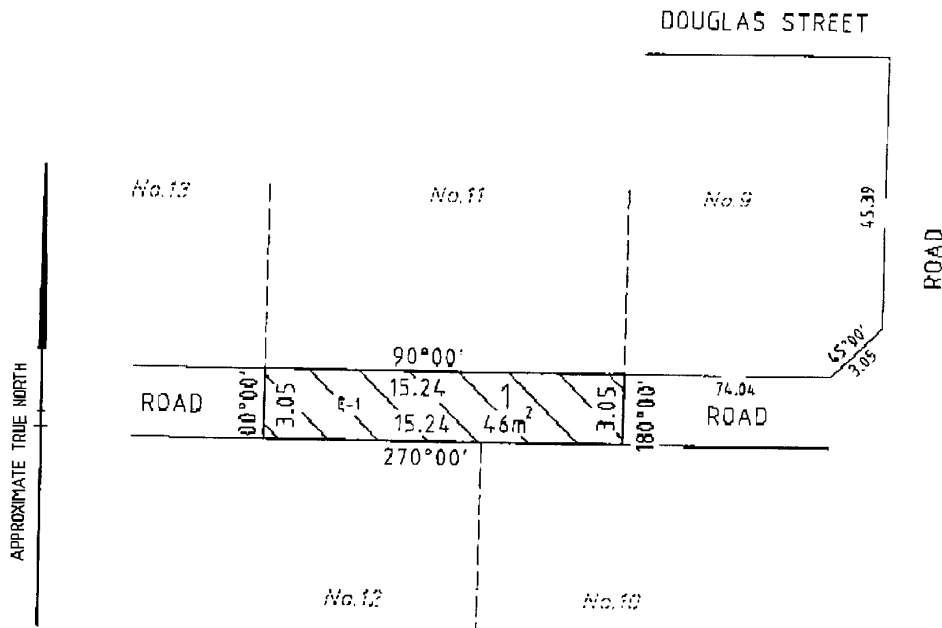

MICHAEL KENNEDY
Chief Executive Officer



**MORNINGTON
PENINSULA**
Shire Council

DISCONTINUANCE OF ROAD RESERVE — PART BENTONS ROAD, MORNINGTON

Pursuant to Section 206 and Schedule 10, Clause 3 of the **Local Government Act 1989**, the Morningson Peninsula Shire Council has formed the opinion that the portion of Bentons Road adjacent to 167 Bentons Road, Mornington, as shown hatched on the plan below, is not reasonably required as a road for public use and has resolved to discontinue the road and transfer the land from the road to the adjoining owner.

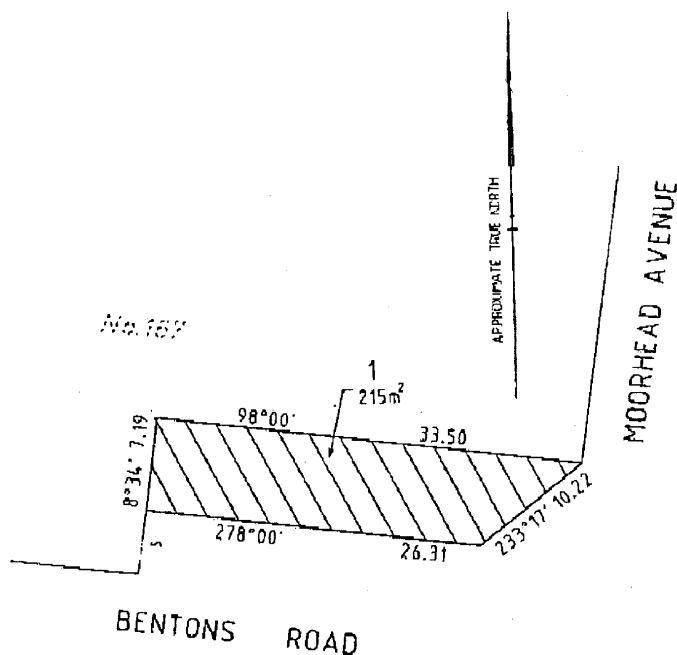

MICHAEL KENNEDY
Chief Executive Officer



ROAD DISCONTINUANCE

Under Section 206 and Schedule 10 Clause 3 of the **Local Government Act 1989** the Campaspe Shire Council at its Ordinary Meeting held on 12 August 2003 and having received no submissions under Section 223 of the Act formed the opinion that the road shown on the plan below is not reasonably required as a road for public use and resolved to discontinue the road and to sell the land from the road to abutting owners subject to any right, power or interest held by Campaspe Shire Council, Telstra, Origin Energy and Coliban Water in the road in connection with sewers, drains, pipes, wires or cables under the control of those authorities in or near the road.

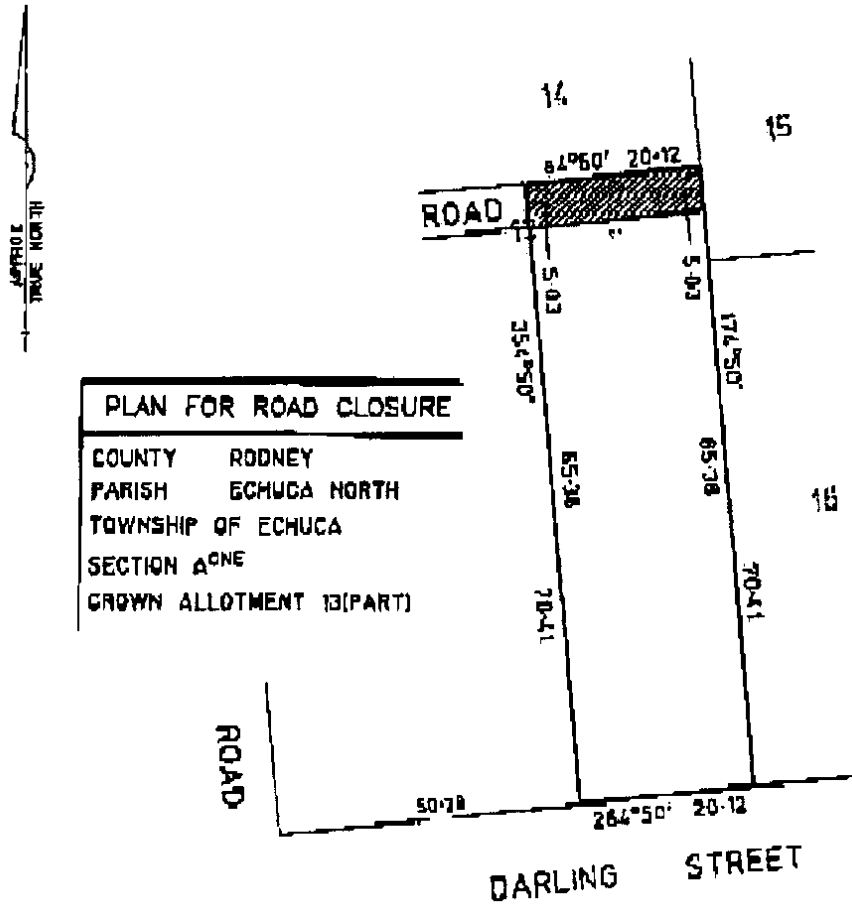

PLAN FOR ROAD CLOSURE
 COUNTY RODNEY
 PARISH ECHUCA NORTH
 TOWNSHIP OF ECHUCA
 SECTION A ONE
 GROWN ALLOTMENT 13(PART)

WAYNE HARVEY
 Chief Executive Officer

COLAC OTWAY SHIRE
 Renaming Portions of Friends Road,
 Yeo and Elliminyt

Notice is hereby given that the Colac Otway Shire on 24 March 2004 resolved:—
 that Council having advertised its intention to rename parts of Friends Road in Yeo and Elliminyt
 and considered a submission received in relation to the proposal, hereby resolves:—

1. the part extending westwards from Old Yeo Road, Yeo to the gully be renamed “Old Friends Road”;
2. that part extending westwards from Forrest Street, Elliminyt to the next gully to be renamed “Florence Road”

in accordance with the provisions of Clause 5, Schedule 10 of the **Local Government Act 1989**.

This name was assigned after a process of public consultation in accordance with the provisions of the **Local Government Act 1989**.

The name shall take effect from the date of publication of this notice.

A plan showing the location of the road is shown below.

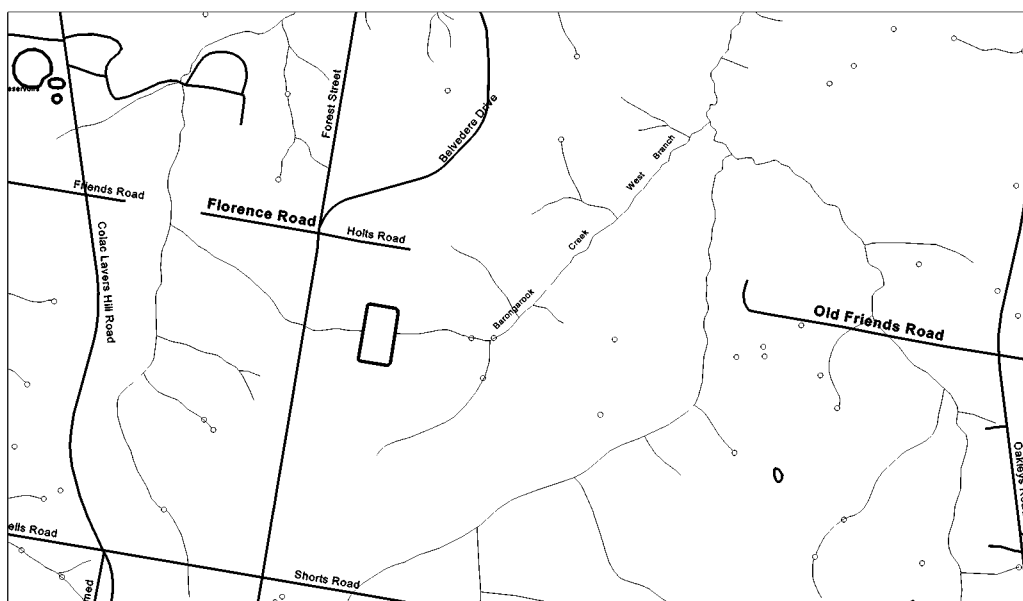

ROB SMALL
Chief Executive Officer



PROPOSED TREE PROTECTION
LOCAL LAW No. 6

Notice is hereby given pursuant to Section 119 (2) of the **Local Government Act 1989** that at a meeting of the Council of Frankston City Council held on 9 March 2004, the Council resolved to give notice of its intention to make Tree Protection Local Law No. 6.

The purpose of the Local Law is to protect trees with a circumference of 110cm at the base. The local law, if adopted, by Council will only apply to building sites where building works in excess of \$20,000 are proposed.

Copies of the proposed Local Law are available at the Civic Centre during office hours, or by contacting Michael Craighead on 9784 1813.

Council will consider written submissions received within fourteen (14) days of the publication of this notice, in accordance with section 223 of the **Local Government Act 1989**.

Any person lodging a written submission may request to be heard in support of their submission and shall be entitled to appear in person, or by a person acting on their behalf, before a meeting of Council.

Persons lodging a written submission should state whether they wish to be heard by Council.

Notice of the meeting date and time will be given to all persons lodging a submission.

STEVE GAWLER
Chief Executive Officer

GLEN EIRA CITY COUNCIL

Road Discontinuance

Acting under Section 206 and Clause 3 of Schedule 10 to the **Local Government Act 1989**, Glen Eira City Council ('Council') at an Ordinary Meeting held on 22 December 2003 has resolved that the roads shown bounded by thick lines on the plan below, be discontinued and retained by Council.

Notwithstanding the said discontinuance Melbourne Water Corporation (South East Water Ltd) shall continue to have and possess the right, power or interest in connection with any sewers, drains or pipes under control of that authority in or over the land shown E-1 on the plan below.

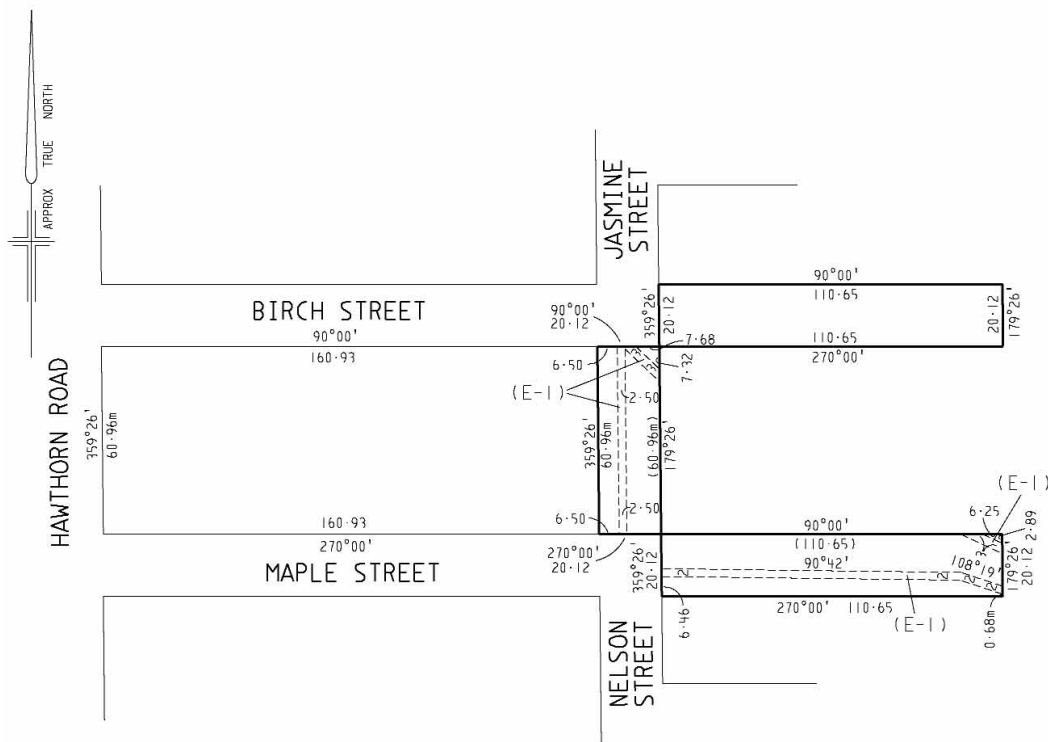

ANDREW NEWTON
Chief Executive Officer

BALLARAT CITY COUNCIL

Local Government Act 1989

Section 206, Clause 3, Schedule 10

Discontinuance of Part of Road

Ballarat City Council hereby gives notice that it has discontinued that part of the road reserve adjoining the property on Consolidated Plan 173750, Yankee Flat Road, Mt. Buninyong, being approximately 111.9m in length by varying width of 8.31m as shown on the plan hereunder.

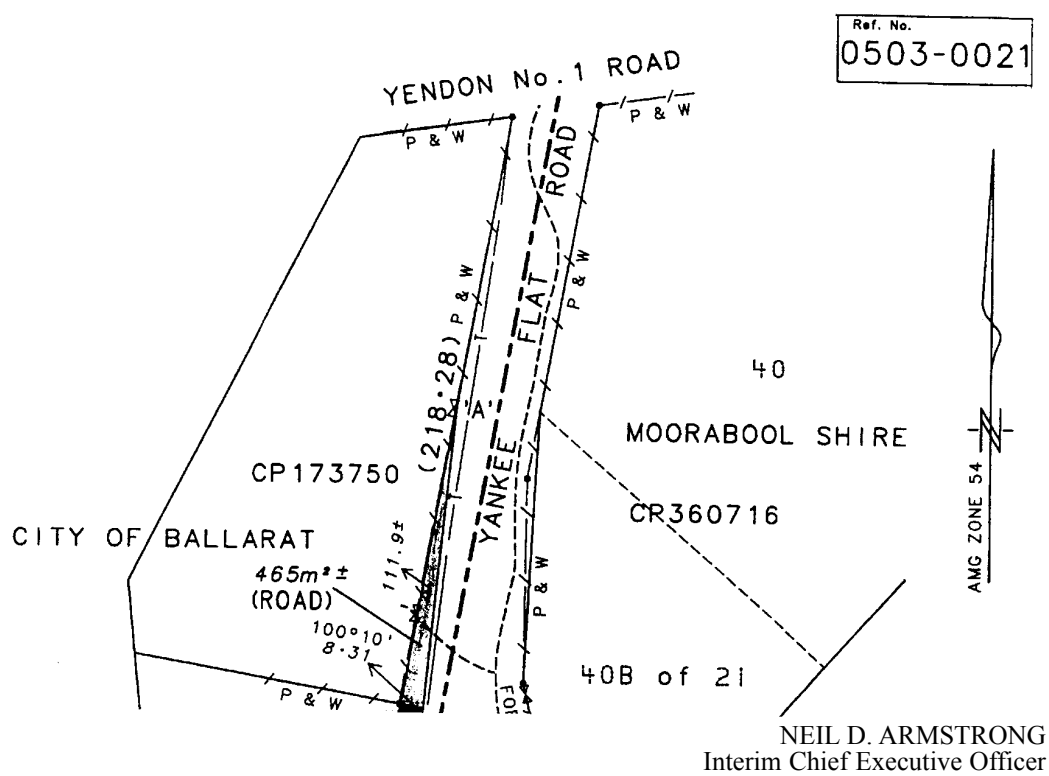

BENALLA RURAL CITY COUNCIL

Proposed Road Discontinuance

Benalla Rural City Council, pursuant to Section 206 and Schedule 10, Clause 3 of the **Local Government Act 1989** ("the Act"), proposes to discontinue the following roads subject to the approval of the Minister for Planning.

Unused road south of CA 5, 6 & 7, Parish of Goorambat.

Unused road south of CA 19A, 19B, 18A & 18B, Parish of Benalla.

Unused road north of CA 28 & 27A, Section T, Parish of Benalla.

Unused road east of CA 27A, Section S of Parish of Benalla.

Also in accordance with Section 207B and schedule 10, Clause 3 ("the Act"), Council proposes to open the section of the Northern Bypass Road passing through ADI property described as follows:

- section of land passing through CA 27A, Section S, Parish of Benalla;
- land passing through the northern part of Pt CA 28, Parish of Benalla;
- and land passing through the southern part of CA 3A, Parish of Benalla.

If the proposal is successful, Council intends to exchange the discontinued roads with the section of roads to be opened, known as the Northern Bypass Road which passes through the ADI property.

In accordance with Section 223 of the Act, any person wishing to make a submission on the above proposals must do so in writing to the undersigned within 14 days of the date of this notice.

Persons making a written submission may request to be heard by Council in support of their submission. Any person requesting to be heard is entitled to appear in person or by a person acting on their behalf, before a meeting of Council or a Committee appointed by Council. An opportunity will be given to any persons making such a submission to be heard by Benalla Rural City Council

Planning and Development Committee at its meeting scheduled for Wednesday 5 May 2004 at 5.30 pm to be held at the Council Chambers, Civic Centre, Fawckner Drive, Benalla.

All submissions will be considered in accordance with Section 223 of the Act.

Following the consideration of any submissions, Council may decide to discontinue/open either/any road, or part of either/any road, or not to discontinue/open either/any roads.

The plan of the sections of road proposed to be discontinued and opened is available for inspection at the Civic Centre Reception, Fawckner Drive, Benalla. Enquiries can be directed to Mr Bassim Girgis, Manager Engineering Services, 5760 2130.

Submissions should be addressed to the Chief Executive Officer, Benalla Rural City Council, PO Box 227, Benalla 3671, or delivered to the Civic Centre, Fawckner Drive, Benalla.

Planning and Environment Act 1987

BRIMBANK PLANNING SCHEME

Notice of Preparation of Amendment

Amendment C69

The Brimbank City Council has prepared Amendment C69 to the Brimbank Planning Scheme.

The land affected by the Amendment is a 36.7ha parcel of land known as the Sunshine Golf Club located at Fitzgerald Road, Sunshine West, and the Masonic Centre with access from Ralph Street ("the site"). The site is described on Certificates of Title Volume 9892, Folio 886 and Volume 9892, Folio 885 respectively.

The Amendment proposes to rezone the site from the Special Use Zone to the Residential 1 Zone; add a new Schedule ("Schedule 12") to the Development Plan Overlay, and make three minor amendments to the Municipal Strategic Statement of the Brimbank Planning Scheme.

You may inspect the Amendment, any documents that support the Amendment and the explanatory report about the Amendment at the following locations: at the office of the planning authority, Brimbank City Council, Keilor Office, Old Calder Highway, Keilor; Harvester Customer Service Centre, 301 Hampshire Road,

Sunshine (next to library) and at the Department of Sustainability and Environment, Planning Information Centre, Upper Plaza, Nauru House, 80 Collins Street, Melbourne.

This can be done during office hours and is free of charge.

Any person who may be affected by the Amendment may make a submission to the planning authority.

The closing date for submissions is Monday 10 May 2004. A submission must be sent to: Brimbank City Council, Attention: Mr Andrew Gray, Manager Statutory Planning, PO Box 106, Keilor, Vic. 3036.

ANDREW GRAY

Manager – Statutory Planning

Signature for the Planning Authority



Planning and Environment Act 1987

GOLDEN PLAINS PLANNING SCHEME

Notice of Preparation of Amendment

Amendment C17

The Golden Plains Shire Council has prepared Amendment C17 to the Golden Plains Planning Scheme.

The Amendment affects:

The land affected by the Amendment is known as 225 Common Road, Inverleigh or Crown Allotments 24 & 25, Parish of Carrah, Inverleigh.

The Amendment proposes to:

The Amendment proposes to rezone the land from Rural Zone (RUZ) to Low Density Residential Zone (LDRZ) and applies the Development Plan Overlay, Schedule 2 (DPO2) to the land.

Where you may inspect this Amendment:

You may inspect the Amendment, any documents that support the Amendment and the explanatory report about the Amendment at the following locations: Golden Plains Shire, Bannockburn Customer Service Centre, 2 Pope Street, Bannockburn, Vic. 3331; Department of Sustainability & Environment, South West Region Office, 180 Fyans Street, South Geelong, Vic. 3220; and Department of Sustainability & Environment, Planning Information Centre,

Upper Plaza, Nauru House, 80 Collins Street, Melbourne, Vic. 3000.

This can be done during office hours and is free of charge.

Any person who may be affected by the Amendment may make a submission to the planning authority, Golden Plains Shire Council.

The closing date for submissions is 10 May 2004. Submissions should be addressed to: Alicia te Wierik, Development Manager, Golden Plains Shire, PO Box 111, Bannockburn, Vic. 3331. Enquiries should be directed to Matt Kelleher, Strategic Planner by telephoning (03) 5220 7111 during business hours.

ROD NICHOLLS
Chief Executive Officer



Planning and Environment Act 1987

GOLDEN PLAINS PLANNING SCHEME

Notice of Preparation of Amendment Amendment C18

The Golden Plains Shire Council has prepared Amendment C18 to the Golden Plains Planning Scheme.

The Amendment affects:

The land affected by the Amendment is known as 44 Faulkner Road, Inverleigh or Lot 8 LP133642, Parish of Carrah, Inverleigh.

The Amendment proposes to:

The Amendment proposes to rezone the land from Rural Zone (RUZ) to Low Density Residential Zone (LDRZ), removes the Salinity Management Overlay (SMO) from the land and applies the Development Plan Overlay, Schedule 2 (DPO2) to the land.

Where you may inspect this Amendment:

You may inspect the Amendment, any documents that support the Amendment and the explanatory report about the Amendment at the following locations: Golden Plains Shire, Bannockburn Customer Service Centre, 2 Pope Street, Bannockburn, Vic. 3331; Department of Sustainability & Environment, South West Region Office, 180 Fyans Street, South Geelong, Vic. 3220; and Department of Sustainability &

Environment, Planning Information Centre, Upper Plaza, Nauru House, 80 Collins Street, Melbourne, Vic. 3000.

This can be done during office hours and is free of charge.

Any person who may be affected by the Amendment may make a submission to the planning authority, Golden Plains Shire Council.

The closing date for submissions is 10 May 2004. Submissions should be addressed to: Alicia te Wierik, Development Manager, Golden Plains Shire, PO Box 111, Bannockburn, Vic. 3331. Enquiries should be directed to Matt Kelleher, Strategic Planner by telephoning (03) 5220 7111 during business hours.

ROD NICHOLLS
Chief Executive Officer

Planning and Environment Act 1987 Section 96C

MOORABOOL PLANNING SCHEME

Notice of the Preparation of an Amendment to a Planning Scheme Amendment C28

The land affected by the Amendment is the site of the former Bacchus Marsh Wastewater Treatment Plant, Avenue of Honour, Bacchus Marsh, further described as Certificate of Title Volume 10208, Folio 507, known as Lot 1 on PS335977F.

The Amendment proposes to rezone the land from Public Use Zone 1 to Rural, to include the land in a Design and Development Overlay (Schedule 2) and to delete the Environmental Audit Overlay. Map 1 Sheet 1 to the Schedule to the Rural Zone will also be amended to include the land.

The authority who requested the Amendment is Western Region Water Authority, c/- Glossop Town Planning.

The Amendment is available for inspection, free of charge, during office hours at the following places: Moorabool Shire Council, 15 Stead Street, Ballan, and 197 Main Street, Bacchus Marsh; Department of Sustainability and Environment, Planning Information Centre, Upper Plaza, Nauru House, 80 Collins Street, Melbourne, and South West Region Office, 402-406 Mair Street, Ballarat.

The Amendment can also be viewed on Council's website at www.moorabool.vic.gov.au

Any person who may be affected by the Amendment may make a submission to the planning authority, Moorabool Shire Council.

The closing date for submission is Monday 10 May 2004.

A submission must be sent in writing to Moorabool Shire Council, PO Box 18, Ballan, Vic. 3342.

ROBERT DOBRZYNSKI
Chief Executive Officer

Planning and Environment Act 1987

MORELAND PLANNING SCHEME

Notice of the Preparation of an Amendment to a Planning Scheme and Notice of an Application for Planning Permit

Amendment C48

Application MPS2004/0070

The land affected by the Amendment is 66–68A Brunswick Road, Brunswick, more particularly described in Certificate of Title Volume 8092, Folio 870.

The land affected by the Application is 66–68A Brunswick Road, Brunswick.

The Amendment proposes to rezone the land from the Business 3 Zone to Business 2 Zone and apply the Environment Audit Overlay.

The Application is for a permit to construct buildings and works to develop offices and three-storey dwellings, use of the land for 8 dwellings, a reduction in the car parking requirements associated with office and dwelling uses, and alteration of access to a declared main road.

The person who requested the Amendment and the applicant for the permit is Harlock Jackson Pty Ltd.

You may inspect the Amendment and the Application, and any documents that support the Amendment and Application, and the explanatory report about the Amendment and Application, at the following locations, Moreland City Council, Moreland Civic Centre, Customer Service Counter, 90 Bell Street, Coburg 3058, and Department of Sustainability and Environment, Planning Information Centre,

Nauru House, 80 Collins Street, Melbourne, Vic. 3000.

This can be done during office hours and is free of charge.

Any person who may be affected by the Amendment or by the granting of the permit may make a submission to the planning authority.

The closing date for submission is Monday 10 May 2004. A submission must be sent to the Moreland City Council and should be addressed as follows:

SUBMISSIONS TO AMENDMENT C48,
Strategic Planning Unit, Moreland City Council,
Locked Bag 10, Moreland 3058.

Signature of Planning Authority
ROGER COLLINS
Director City Development

Planning and Environment Act 1987

MURRINDINDI PLANNING SCHEME

Notice of Amendment

Amendment C10

Murrindindi Shire Council has prepared Amendment C10 to the Murrindindi Planning Scheme.

The Amendment affects general areas throughout the municipality.

The Amendment:

- rezones various parcels of land in the municipality to make corrective changes to reflect land ownership and use, including rezoning Goulburn Valley Water sites to Public Use 1 (Service and Utility);
- reduces the application of the Environmental Significance Overlay in townships and public use sites;
- removes the Development Plan Overlay 1 from a site in The Boulevard, Eildon;
- removes the Erosion Management Overlay from public land east of the Toolangi township;
- makes minor changes to four Clause 22 policies (Agriculture and rural land, Catchment management and landcare, Remnant vegetation and grasses and Dams) to reflect current strategies, requirements and department procedures;

- replaces the schedules to the Environmental Significance Overlay, Vegetation Protection Overlay, Erosion Management Overlay and both schedules to the Significant Landscape Overlay to reduce minor planning permit requirements and referrals;
- replaces Schedule 1 to the Development Plan Overlay to introduce performance based decision guidelines for subdivision, design and development in the Residential 1 Zone.

A copy of the Amendment, supporting documents and explanatory report can be inspected, free of charge, during office hours, at: The Alexandra, Yea or Kinglake offices of the planning authority, Murrindindi Shire Council; Department of Sustainability and Environment regional office, 35 Sydney Road, Benalla; and Department of Sustainability and Environment head office (Planning and Development), Nauru House, 80 Collins Street, Melbourne.

Any person who may be affected by the Amendment may make a submission to the planning authority. The closing date for submissions is 10 May 2004. Submissions about the Amendment must be sent to D. D. Hogan, Chief Executive Officer, Murrindindi Shire Council, PO Box 138, Alexandra, 3714 by 10 May 2004.

D. D. HOGAN
Chief Executive Officer
Murrindindi Shire Council

Planning and Environment Act 1987

SOUTH GIPPSLAND PLANNING SCHEME

Notice of the Preparation of an Amendment
to a Planning Scheme

Notice of an Application for Planning Permit
Amendment C17

Application 2003/537

The land affected by the Amendment is situated along Henrys Road and Berrys Road, Nyora, being L3 PS216515C, LB PS435504U and L1 PS212480R.

The land affected by the Application for a planning permit is situated along Henrys Road and Berrys Road, Nyora, being L3 PS216515C, LB PS435504U and L1 PS212480R.

The Amendment proposes to change the Planning Scheme by rezoning land situated

along Henrys Road and Berrys Road, Nyora, being L3 PS216515C, LB PS435504U and L1 PS212480R from a Rural Zone to a Rural Living Zone to allow minimum lot sizes of 1.0 ha.

The Application is for a permit to subdivide L3 PS216515C, LB PS435504U and L1 PS212480R into 24 lots ranging in size from 1.0 ha to 3.35 ha.

The person who requested the Amendment and the applicant for the permit is Beveridge Williams & Co on behalf of WS & LL Berry.

You may inspect the Amendment and the Application, and any documents that support the Amendment and Application, and the explanatory report about the Amendment and Application, at the following offices: South Gippsland Shire Council, 9 Smith Street, Leongatha; Department of Sustainability & Environment, Planning Information Centre, 80 Collins Street, Melbourne; and Department of Sustainability & Environment Regional Office, 71 Hotham Street, Traralgon.

This can be done during office hours and is free of charge.

Any person who may be affected by the Amendment or by the granting of the permit may make a submission to the planning authority. The closing date for submissions is 10 May 2004. A submission must be sent to the Chief Executive, South Gippsland Shire Council, Private Bag 4, Leongatha 3953.

JOSEPH CULLEN
Chief Executive
South Gippsland Shire Council

Planning and Environment Act 1987

WHITTLESEA PLANNING SCHEME

Notice of Amendment

Amendment C60

Whittlesea City Council has prepared Amendment C60 to the Whittlesea Planning Scheme. The Whittlesea City Council is also the planning authority for the Amendment.

The Amendment applies to land at 2025 Merriang Road, Beveridge which is also described as Part Crown Allotments 20, 21, 28 and 29, Parish of Merriang. The land is further described as the Camoola property.

The full extent of the land is currently affected by a Heritage Overlay under the Whittlesea Planning Scheme. The Amendment proposes to remove the Heritage Overlay from areas which do not contain documented cultural heritage values.

The Amendment can be inspected free of charge during office hours at: Department of Sustainability and Environment, Planning Information Centre, Upper Plaza, Nauru House, 80 Collins Street, Melbourne, Vic. 3000; and City of Whittlesea, Civic Centre, Ferres Boulevard, South Morang, Vic. 3752.

Submissions to the Amendment must be sent to: The Chief Executive Officer, City of Whittlesea, Locked Bag 1, Bundoora, Vic. 3083 by Friday 14 May 2004.

GRAEME BRENNAN
Chief Executive Officer

Creditors, next-of-kin and others having claims against the estate of any of the undermentioned deceased persons are required to send particulars of their claims to State Trustees Limited, ABN 68 064 593 148, 168 Exhibition Street, Melbourne, Victoria 3000, the personal representative, on or before 14 June 2004 after which date State Trustees Limited may convey or distribute the assets having regard only to the claims of which State Trustees Limited then has notice.

BONIFACE, Raymond George, formerly of 65 Ormond Esplanade, Elwood, but late of St Michaels Private Nursing Home, 1 Omama Road, Murrumbeena, and who died on 20 December 2003.

BUCKLEY, George Peter, late of Unit 4, 199 McLeod Road, Patterson Lakes, retired and who died on 5 March 2004.

CLISSOLD, Donald Lee, late of 27 Webster Street, Horsham, Victoria 3400, tank cleaner, and who died on 22 August 2000.

MAINS, Lorna Hester, late of 77 Arthur Street, Fairfield, home duties, and who died on 4 February 2004.

Dated 5 April 2004

LAURIE TAYLOR
Estate Manager
State Trustees Limited

Creditors, next-of-kin and others having claims against the estate of any of the undermentioned deceased persons are required to send particulars of their claims to State Trustees Limited, ABN 68 064 593 148, 168 Exhibition Street, Melbourne, Victoria 3000, the personal representative, on or before 10 June 2004 after which date State Trustees Limited may convey or distribute the assets having regard only to the claims of which State Trustees Limited then has notice.

BAINES, Marie Alice, late of Radford Private Nursing Home, 87–93 Radford Road, Reservoir, and who died on 11 February 2004.

FRANCIS, Leo, formerly of 38 Valentine Street, Bendigo, but late of Simpkin House Nursing Home, Holdsworth Road, Bendigo, pensioner and who died on 13 December 2003.

GHIOCAS, Lidia, late of 15–17 Strettle Street, Thornbury, widow and who died on 30 November 2000.

GRANT, Marjorie Caroline, late of Lorikeet Lodge, 24–28 Moorooduc Highway, Frankston, retired and who died on 12 March 2004.

HALLIGAN, Margaret Jean, late of Arlington Private Nursing Home, 3 Collins Street, Thornbury, pensioner, and who died on 22 March 2004.

KRAUSE, Albert Victor Kevin Hamilton, formerly of 88 Liston Avenue, Keon Park, but late of Macleod Nursing Home, 118 Somers Avenue, Macleod, retired and who died on 15 March 2004.

LAURIE, Robin Bruce, late of 201 Spring Street, Melbourne, company director and who died on 8 February 2004.

MULLINS, Noelene Alma, late of 4 Woodview Place, Knoxfield, home duties, and who died on 3 July 2003.

PAAR, Laszlo, late of 1/1 Purser Avenue, Ringwood East, Victoria 3135, pensioner and who died on 3 February 2004.

ROMANYSZYN, Michael, formerly of Toorak House Nursing Home, 1011 Toorak Road, Camberwell, Victoria 3124, but late of Broughton Lea Nursing Home, 9 Broughton Road, Surrey Hills, Victoria 3127, retired and who died on 18 March 2004.

SMITH, Edna Pearl, late of Lorikeet Lodge Nursing Home, 24–28 Moorooduc Highway, Frankston, pensioner, and who died on 17 January 2004.

STORK, Betty Lorraine, late of Lyndoch Nursing Home, Hopkins Road, Warrnambool, Victoria 3280, pensioner and who died on 21 January 2004.

ZDERSKI, Kate Louise, late of Westgate Private Nursing Home, 4 William Street, Newport, pensioner and who died on 23 February 2004.

Dated 1 April 2004

Laurie Taylor
Estate Manager
State Trustees Limited

EXEMPTION

Application No A66 of 2004

The Victorian Civil & Administrative Tribunal (the Tribunal) has considered an application pursuant to Section 83 of the **Equal Opportunity Act 1995** (the Act) by WISE Employment Ltd (the applicant). The application for exemption is to enable the applicant to advertise for and offer employment as part of its "Make It Work" program to male volunteers to become mentors for adult males who are on bail.

Upon reading the material in support of the application, the Tribunal is satisfied that is appropriate to grant an exemption from Sections 13, 100 and 195 of the Act to enable the applicant to advertise for and employ male volunteers in its "Make It Work" program to become mentors for adult males who are on bail.

In granting this exemption, the Tribunal noted that the applicant is a not-for-profit organization providing vocational services for disadvantaged people, and in particular, a program entitled "Make It Work" which is directed at assisting adults on bail by providing mentors to them. The Tribunal noted that overwhelming majority (96%) of persons requiring mentoring under the "Make It Work" program offered by the applicant are males; that persons to be mentored are matched with appropriate volunteers; and that the 15 female volunteer mentors involved in the program have elected not to mentor males. The Tribunal noted that there is a critical shortage of male volunteers relative to male persons requiring mentors, and that the exemption is necessary to enable the "Make It Work" program viable.

The Tribunal hereby grants an exemption from the operation of Sections 13, 100 and 195 of the Act to enable the applicant to advertise for

and employ male volunteers to become mentors in its "Make It Work" program.

This exemption is to remain in force from the day on which notice of the exemption is published in the Government Gazette until 8 April 2007.

Dated 2 April 2004.

Mrs S. DAVIS
Deputy President

Department of Treasury and Finance

SALE OF CROWN LAND BY PUBLIC TENDER

Closing Date: Wednesday 12 May 2004 at 2.00 p.m.

Reference: 2001/03043.

Address of Property: Moore Street, Warrnambool.

Crown Description: Crown Allotments 2003, 2004, 2005 & 2006, Section A, Parish of Wangoom.

Terms of Sale: 1% on Tender Lodgement, 9% upon acceptance of Tender. Balance 90 days.

Area: 19.32 ha approximately.

Officer Co-ordinating Sale: Mark French, Victorian Government Property Group, Department of Treasury and Finance, 5/1 Treasury Place, Melbourne, Vic. 3002.

Selling Agents: Knight Frank, 360 Collins Street, Melbourne, Vic. 3000.

Ludeman Real Estate, 124 Liebig Street, Warrnambool, Vic. 3280.

JOHN LENDERS MP
Minister for Finance

Chinese Medicine Registration Act 2000

Following a formal hearing into the professional conduct of Mr Safet (Sani) BADIC, registration number A/21, registered in the division of acupuncturists, a panel appointed by the Chinese Medicine Registration of Victoria, found that Mr Badic had obtained registration with the Board by fraud or misrepresentation. As a result of this determination the board was obliged by section 16(4) of the Act to cancel Mr Badic's registration.

DEBRA GILLICK
Registrar

Co-operatives Act 1996PRIMEAT CO-OPERATIVE LIMITED
TRAFALGAR HIGH SCHOOL
CO-OPERATIVE LTD

Notice is hereby given in pursuance of Section 316(1) of the **Co-operatives Act 1996** and Section 601AB(3)(e) of the **Corporations Act 2001** that, at the expiration of two months from the date hereof, the names of the aforementioned co-operatives will, unless cause is shown to the contrary, be struck off the register and the co-operatives will be dissolved. Dated at Melbourne 6 April 2004

ANDREW LEVENS
Deputy Registrar of Co-operatives

Country Fire Authority Act 1958

VARIATION OF FIRE DANGER PERIOD

In pursuance of the powers conferred by Section 4 of the **Country Fire Authority Act 1958**, I, Neil Graeme Bibby, Chief Executive Officer of the Country Fire Authority, after consultation with the Secretary to the Department of Sustainability and Environment, hereby vary the declaration of the Fire Danger Periods previously published in the Government Gazette by declaring that such Fire Danger Periods shall end in respect of the undermentioned Municipal Districts of Municipalities or parts of Municipalities specified.

To terminate from 0100 hours 12 April 2004: Bass Coast Shire Council, Cardinia Shire Council, City of Casey, City of Frankston, City of Greater Dandenong (those portions not included in the Metropolitan Fire District), City of Kingston (those portions not included in the Metropolitan Fire District), French Island, Mornington Peninsula Shire Council, Wellington Shire Council, La Trobe City Council, City of Warnambool.

Shire of Moyne (part) that portion west and south of the line commencing at the shire boundary at the corner of Glenthompson—Caramut Road and Peterson Lane; then south along Glenthompson—Caramut Road until it intersects with Caramut—Chatsworth Road; then generally east and north east along Caramut—Chatsworth Road until it intersects with Boortkoi Road; then east along Boortkoi Road until it intersects with Boortkoi Lane; then south west along Boortkoi Lane until it

intersects with Hamilton Highway; then east and south east along Hamilton Highway until it intersects with Hopkins Highway; then south west along Hopkins Highway until it intersects with Sagnols Lane; then east from that point along the road reserve to Hood Avenue; then east along Hood Avenue, Mortlake—Terang Road and Purcells Lane until the intersection of Purcells Lane and Pound Lane; then northerly along Pound Lane until it intersects with Hamilton Highway; then east north east along Hamilton Highway until it intersects with Mount Emu Creek.

Shire of Southern Grampians (part) that part east of the following alignment:—commencing at a point on the Glenelg River at the south eastern angle of Allotment 2, Section II, Parish of Balmoral; thence generally south westerly, southerly easterly and south easterly by that river to where the eastern boundary of the Parish of Pendyk Pendyk abut there on; thence southerly and westerly by the eastern and southern boundaries of the parish to the south-western angle thereof; thence southerly by the eastern boundary of the Parish of Bil-Bil-Wyt to the south eastern angle of Allotment 133 in that parish; thence westerly by a road to the south-western angle of that allotment; thence southerly by a road to the southern boundary of the parish; thence westerly by that boundary to the north-western angle of the Parish of Gatum Gatum; thence southerly by the western boundary of the parish to the south-western angle of Allotment 5, Section 1; thence south-easterly by a road to the northern angle of Allotment 14, Section 3; thence south-westerly by the western boundaries of Allotments 14 and 16 and a line to the western boundary of the parish; thence southerly by that boundary and a line to the north-western angle of Allotment 4, Section 1, parish of Toolang; thence further southerly by the western boundary of that allotment to a point in line with the southern boundary of Allotment 5; thence easterly by a line to the south-western angle of that allotment; thence southerly by a line to the north-western angle of Allotment 1B, Section 5; thence further southerly by a road and the western boundaries of Allotments 4A and 4B, Section 17 to the northern boundary of the Parish of Redruth; thence westerly by that boundary to the eastern angle of Allotment 2B, Section 26 in that parish; thence south-westerly by a road to the southern angle of Allotment 1A; thence southerly by a line to the north-western angle of Allotment 1A, Section 15; thence further southerly by the

western boundary of the parish to the Wannon River; thence generally westerly by that river to the western boundary of the Parish of Murndal; thence southerly by that boundary and easterly, southerly and north-easterly by the northern boundary of the Parish of Branxholme and further north-easterly by the Henty Highway to the road on the northern boundary of Section 12, Parish of Audley; thence easterly by that road to the north-eastern angle of Section 13, and southerly by a road to the shire boundary.

To terminate from 0100 hours 13 April 2004: Horsham Rural City Council (remainder), West Wimmera Shire Council (part), that part north of the Mosquito Creek.

N. BIBBY
Chief Executive Officer

Forests Act 1958, No. 6254

VARIATION OF THE PROHIBITED PERIOD

In pursuance of the powers conferred by section 3, sub-section (2) of the **Forests Act 1958**, I, Gary Morgan, delegated officer for the Minister for Environment in the State of Victoria, hereby vary the Prohibited Period for all land within the Fire Protected Area (other than State forest, National park and protected public land) within the municipalities nominated in the schedule below:

SCHEDULE 1

The Prohibited Period shall terminate at 0100 hours on Monday 12 April 2004 in the following municipalities:

Baw Baw Shire Council, Latrobe Shire Council, Wellington Shire Council.

GARY MORGAN
Chief Fire Officer
Department of Sustainability
and Environment
Delegated Officer,
pursuant to section 11,
**Conservation Forests
and Land Act 1987**

Interpretation of Legislation Act 1984

ELECTRICITY SAFETY (INSTALLATIONS) REGULATIONS 1999

Notice is given under section 32(4)(a)(ii) of the **Interpretation of Legislation Act 1984** that the Standard AS/NZS 3760:2001 "In-service safety inspection and testing of electrical equipment", which is incorporated in the

Electricity Safety (Installations) Regulations 1999, has been replaced by AS/NZS 3760:2003.

A copy of the new Standard has been lodged with the Clerk of the Parliaments.

IAN K. GRAHAM
Chief Electrical Inspector

Interpretation of Legislation Act 1984

ELECTRICITY SAFETY (EQUIPMENT EFFICIENCY) REGULATIONS 1999

Notice is given under section 32(4)(a)(ii) of the **Interpretation of Legislation Act 1984** that:

- AS/NZS 2040.1:1998 "Performance of household electrical appliances — Clothes washing machines — Part 1: Energy consumption and performance";
- AS/NZS 3823.1.2:2001 "Performance of electrical appliances — Airconditioners and heat pumps — Part 1.2 Test methods — Ducted airconditioners and air-to-air heat pumps — Testing and rating for performance"; and
- AS/NZS 2442.1:1996 "Performance of household electrical appliances — Rotary clothes dryers — Part 1: Energy consumption and performance"

each of which is incorporated in the Electricity Safety (Equipment Efficiency) Regulations 1999, have been amended.

Copies of the amendments have been lodged with the Clerk of the Parliaments.

IAN K. GRAHAM
Chief Electrical Inspector



Heritage
VICTORIA

Heritage Act 1995

NOTICE OF REGISTRATION

As Executive Director for the purpose of the **Heritage Act 1995**, I give notice under section 46 that the Victorian Heritage Register is amended by including the Heritage Register Number 2049 in the category described as a Heritage place is now described as:

NYLEX Sign, Gough Street & Harcourt Parade, Richmond, Yarra City Council.

EXTENT:

All of the sky-sign known as the Nylex sign and its supporting structure marked B1 on Diagram 2049 held by the Executive Director.

Dated 8 April 2004

RAY TONKIN
Executive Director

**Heritage Act 1995**

NOTICE OF REGISTRATION

As Executive Director for the purpose of the **Heritage Act 1995**, I give notice under section 46 that the Victorian Heritage Register is amended by including the Heritage Register Number 2051 in the category described as a Heritage place:

Pavilion Classroom, Jory Street, Natimuk, Horsham Rural City Council.

EXTENT:

1. All the building marked B1 on Diagram Number 2051 held by the Executive Director.
2. All the land marked L1 on Diagram Number 2051 held by the Executive Director.

Dated 8 April 2004

RAY TONKIN
Executive Director

**Heritage Act 1995**

NOTICE OF REGISTRATION

As Executive Director for the purpose of the **Heritage Act 1995**, I give notice under section 46 that the Victorian Heritage Register is amended by including the Heritage Register Number 2059 in the category described as a Archaeological Place /Heritage place:

Hopetoun Cemetery, Western Freeway, Bacchus Marsh, Moorabool Shire Council.

EXTENT:

1. All the land marked L1 on the Diagram 2059 held by the Executive Director.
2. All archaeological deposits and relics including but not limited to the stone footings, brick scatters and other artefacts associated with the ruins of the chapel/school house built in 1850 marked F1 on the Diagram 2059 held by the Executive Director.
3. All marked and unmarked burials including grave markers, grave surrounds (cast iron and timber), footstones, headstones, altar slabs and mortuary monuments.
4. All the nineteenth century plantings and landscape features.
5. All fences, fence posts and gates.

Dated 8 April 2004

RAY TONKIN
Executive Director

**Heritage Act 1995**

NOTICE OF REGISTRATION

As Executive Director for the purpose of the **Heritage Act 1995**, I give notice under section 46 that the Victorian Heritage Register is amended by including the Heritage Register Number 172 in the category described as a Heritage place is now described as:

Royal Terrace, 50–68 Nicholson Street, Fitzroy, Yarra City Council.

EXTENT:

1. All the buildings and associated structures, stables and outbuildings known as Royal Terrace, being marked B1 on diagram H172 held by the Executive Director, and the flagstone pavement to Nicholson Street.
2. All the land labelled L1 on diagram H172 held by the Executive Director.

Dated 8 April 2004

RAY TONKIN
Executive Director

Mineral Resources Development Act 1990EXEMPTION FROM EXPLORATION
LICENCE OR MINING LICENCE

I, Richard Aldous, Executive Director Minerals and Petroleum, pursuant to section 7 of the **Mineral Resources Development Act 1990** and under delegation by the Minister for Energy Industries and Resources—

1. HEREBY EXEMPT all that Crown land situated within the boundaries of exploration licence application 4815 that has been excised from the application, from being subject to an exploration licence or mining licence.
2. Subject to paragraph 3, this exemption applies until the expiration of 2 years after the grant of the licence (if the licence is granted), or until the expiration of 28 days after the application lapses or is withdrawn or refused.
3. This exemption is REVOKED in respect of any land that ceases to lie within the boundaries of the application or licence, at the expiration of 28 days after the said land ceases to lie within the boundaries of the application or licence.

Dated 1 April 2004

RICHARD ALDOUS
Executive Director
Minerals and Petroleum

**Trans-Tasman Mutual Recognition
(Victoria) Act 1998**ENDORSEMENT OF REGULATIONS
MADE UNDER THE TRANS-TASMAN
MUTUAL RECOGNITION ACT 1997 OF
THE COMMONWEALTH

I, Stephen Phillip Bracks, as the designated person for the State of Victoria and in accordance with section 42 of the **Trans-Tasman Mutual Recognition Act 1997** of the Commonwealth, endorse the proposed regulations set out in Appendix A for the purposes of sections 43(1) and 48(5) of that Act.

Dated 2 April 2004

STEVE BRACKS
Premier

APPENDIX A

Trans-Tasman Mutual Recognition
Amendment Regulations 2004 (No.)¹

1 Name of Regulations

These Regulations are the Trans-Tasman Mutual Recognition Amendment Regulations 2004 (No.).²

2 Commencement

These Regulations commence on the date of their notification in the Gazette.

3 Amendment of Trans-Tasman Mutual Recognition Regulations 1999

Schedule 1 amends the Trans-Tasman Mutual Recognition Regulations 1999.

SCHEDULE 1

Amendment

(regulation 3)

[1] Regulation 5

omit

30 April 2004.

insert

30 April 2005.

Notes

1. These Regulations amend Statutory Rules 1999 No. 60, as amended by 2000 No. 51; 2001 No. 75; 2002 No. 78; 2003 No. 72.
2. Notified in the Commonwealth of Australia Gazette on 2004.

Victorian Institute of Teaching Act 2001NOTIFICATION CANCELLING
REGISTRATION OF A TEACHER

Pursuant to section 25 of the **Victorian Institute of Teaching Act 2001** the Victorian Institute of Teaching must disqualify a registered teacher from teaching and cancel their registration where that person has been convicted or found guilty at anytime in Victoria or elsewhere, of a sexual offence.

On 1 March 1976 RONALD THOMAS FORBES BINGHAM (date of birth: 22 October 1950) was found guilty of a sexual offence in Victoria under section 68(3A) of the **Crimes Act 1958** (Vic).

On 31 March 2004 RONALD THOMAS FORBES BINGHAM was disqualified from teaching and his registration as a teacher in Victoria was cancelled from 31 December 2002.

Dated 31 March 2004

JANET SHERRY

Chairperson

Disciplinary Proceedings Committee
Victorian Institute of Teaching

Fisheries Act 1995

FISHERIES NOTICE NO. 3/2004

I, Bob Cameron, Minister for Agriculture, after consultation with the Aquaculture Committee of the Fisheries Co-Management Council and the Victorian Aquaculture Council make the following Fisheries Notice:

Dated 24 March 2004

BOB CAMERON

Minister for Agriculture

**Aquaculture (Crown Land) Licence and Aquaculture (Crown Land) Type A Licence
Western Port/Port Phillip Bay**

1) *Title*

This notice may be cited as the Pinnacle Channel Aquaculture Fisheries Reserve Notice No. 3/2004.

2) *Objective*

The objective of this notice is to specify a measure for the protection of Aquaculture in Western Port/Port Phillip Bay as set out in paragraph 6 of this notice.

3) *Definitions*

“Pinnacle Channel Aquaculture Fisheries Reserve” otherwise referred to in this Notice as ‘the Reserve’ means the areas of Western Port/Port Phillip Bay which are defined by the following co-ordinates:

- Northern Section:

Northern Block	Datum AMG 66 (Degrees and decimal minutes)	
	Latitude South	Longitude East
North West	38° 14.347'	144° 48.785'
North East	38° 14.000'	144° 49.900'
South West	38° 15.783'	144° 49.502'
South East	38° 15.437'	144° 50.618'

- Southern Section:

Southern Block	Datum AMG 66 (Degrees and decimal minutes)	
	Latitude South	Longitude East
North West	38° 16.663'	144° 49.982'
North East	38° 16.316'	144° 51.098'
South West	38° 18.100'	144° 50.700'
South East	38° 17.753'	144° 51.816'

4) *Authorising provision*

This notice is made under section 152(1)(f) of the **Fisheries Act 1995**.

5) *Commencement*

This notice comes into operation on the day on which it is published in the Victoria Government Gazette.

6) *Measure*

- a) An Aquaculture (Crown Land) Licence or an Aquaculture (Crown Land) Type A Licence issued, varied or transferred after the commencement of this notice shall not specify a site within the Pinnacle Channel Aquaculture Fisheries Reserve to authorise aquaculture activities.

-
- b) Clause 6 will not operate to prevent a licence or licences from being issued, varied or transferred where:
- i) an Aquaculture (Crown Land) Licence or an Aquaculture (Crown Land) Type A Licence which specifies a site or sites within the Reserve is surrendered and
 - (1) an Aquaculture (Crown Land) Licence or an Aquaculture (Crown Land) Type A Licence is issued which specifies the same site or sites within the Reserve as in the surrendered licence; or
 - (2) an Aquaculture (Crown Land) Licence or an Aquaculture (Crown Land) Type A Licence which specifies a site or sites within the Reserve is varied to include a site or sites within the Reserve that are specified in the surrendered licence;
 - ii) an Aquaculture (Crown Land) Licence or an Aquaculture (Crown Land) Type A Licence which specifies a site or sites within the Reserve is varied or transferred and the same site or sites within the Reserve are specified in the varied or transferred licence, unless one or more of the sites have been sought by the licence holder to be removed.
- 7) *Application of Notice to Declared Fisheries Reserve*
This notice applies to the Fisheries (Declaration of Pinnacle Channel Aquaculture Fisheries Reserve) Order 2003.
- 8) *Revocation*
Unless sooner revoked, this fisheries notice will be revoked on the first to occur of the following:
- a) the declaration of a management plan including the Pinnacle Channel Aquaculture Fisheries Reserve; or
 - b) 12 months after the day on which this fisheries notice comes into force.
-

Fisheries Act 1995

FISHERIES NOTICE NO. 4/2004

I, Bob Cameron, Minister for Agriculture, after consultation with the Aquaculture Committee of the Fisheries Co-Management Council and the Victorian Aquaculture Council make the following Fisheries Notice:

Dated 24 March 2004

BOB CAMERON

Minister for Agriculture

**Aquaculture (Crown Land) Licence and Aquaculture (Crown Land) Type A Licence
Western Port/Port Phillip Bay**

1) *Title*

This notice may be cited as the Clifton Springs Aquaculture Fisheries Reserve Notice No. 4/2004.

2) *Objective*

The objective of this notice is to specify a measure for the protection of Aquaculture in Western Port/Port Phillip Bay as set out in paragraph 6 of this notice.

3) *Definitions*

“Clifton Springs Aquaculture Reserve” otherwise referred to in this Notice as ‘the Reserve’, means the area of Western Port/Port Phillip Bay which is defined by the following co-ordinates:

	Datum AMG 66 (Degrees and decimal minutes)	
	Latitude South	Longitude East
North West	38°07.772’	144°33.355’
North East	38°06.829’	144°35.062’
South West	38°08.231’	144°33.754’
South East	38°07.294’	144°35.477’

4) *Authorising provision*

This notice is made under section 152(1)(f) of the **Fisheries Act 1995**.

5) *Commencement*

This notice comes into operation on the day on which it is published in the Victoria Government Gazette.

6) *Measure*

- a) An Aquaculture (Crown Land) Licence or an Aquaculture (Crown Land) Type A Licence issued, varied or transferred after the commencement of this notice shall not specify a site within the Clifton Springs Aquaculture Fisheries Reserve to authorise aquaculture activities.
- b) Clause 6 will not operate to prevent a licence or licences from being issued, varied or transferred where:
 - i) an Aquaculture (Crown Land) Licence or an Aquaculture (Crown Land) Type A Licence which specifies a site or sites within the Reserve is surrendered and
 - (1) an Aquaculture (Crown Land) Licence or an Aquaculture (Crown Land) Type A Licence is issued which specifies the same site or sites within the Reserve as in the surrendered licence; or

-
- (2) an Aquaculture (Crown Land) Licence or an Aquaculture (Crown Land) Type A Licence which specifies a site or sites within the Reserve is varied to include a site or sites within the Reserve that are specified in the surrendered licence;
 - i) an Aquaculture (Crown Land) Licence or an Aquaculture (Crown Land) Type A Licence which specifies a site or sites within the Reserve is varied or transferred and the same site or sites within the Reserve are specified in the varied or transferred licence, unless one or more of the sites have been sought by the licence holder to be removed.
 - 7) *Application of Notice to Declared Fisheries Reserve*
This notice applies to the Fisheries (Declaration of Clifton Springs Aquaculture Fisheries Reserve) Order 2003.
 - 8) *Revocation*
Unless sooner revoked, this fisheries notice will be revoked on the first to occur of the following:
 - a) the declaration of a management plan including the Clifton Springs Aquaculture Fisheries Reserve; or
 - b) 12 months after the day on which this fisheries notice comes into force.
-

Fisheries Act 1995

FISHERIES NOTICE NO. 5/2004

I, Bob Cameron, Minister for Agriculture, after consultation with the Aquaculture Committee of the Fisheries Co-Management Council and the Victorian Aquaculture Council make the following Fisheries Notice:

Dated 24 March 2004

BOB CAMERON

Minister for Agriculture

**Aquaculture (Crown Land) Licence and Aquaculture (Crown Land) Type A Licence
Western Port/Port Phillip Bay**

1) *Title*

This notice may be cited as the Grassy Point Aquaculture Fisheries Reserve Notice No. 5/2004.

2) *Objective*

The objective of this notice is to specify a measure for the protection of Aquaculture in Western Port/Port Phillip Bay as set out in paragraph 6 of this notice.

3) *Definitions*

“Grassy Point Aquaculture Fisheries Reserve” otherwise referred to in this Notice as ‘the Reserve’, means the area of Western Port/Port Phillip Bay which is defined by the following co-ordinates:

	Datum AMG 66 (Degrees and decimal minutes)	
	Latitude South	Longitude East
North West	38° 06.089’	144° 40.613’
North East	38° 06.118’	144° 42.110’
South West	38° 06.711’	144° 40.588’
South East	38° 06.734’	144° 42.099’

4) *Authorising provision*

This notice is made under section 152(1)(f) of the **Fisheries Act 1995**.

5) *Commencement*

This notice comes into operation on the day on which it is published in the Victoria Government Gazette.

6) *Measure*

- a) An Aquaculture (Crown Land) Licence or an Aquaculture (Crown Land) Type A Licence issued, varied or transferred after the commencement of this notice shall not specify a site within the Grassy Point Aquaculture Fisheries Reserve to authorise aquaculture activities.
- b) Clause 6 will not operate to prevent a licence or licences from being issued, varied or transferred where:
- ii) an Aquaculture (Crown Land) Licence or an Aquaculture (Crown Land) Type A Licence which specifies a site or sites within the Reserve is surrendered and
- (1) an Aquaculture (Crown Land) Licence or an Aquaculture (Crown Land) Type A Licence is issued which specifies the same site or sites within the Reserve as in the surrendered licence; or
- (2) an Aquaculture (Crown Land) Licence or an Aquaculture (Crown Land) Type A Licence which specifies a site or sites within the Reserve is varied to include a site or sites within the Reserve that are specified in the surrendered licence; or

-
- i) an Aquaculture (Crown Land) Licence or an Aquaculture (Crown Land) Type A Licence which specifies a site or sites within the Reserve is varied or transferred and the same site or sites within the Reserve are specified in the varied or transferred licence, unless one or more of the sites have been sought by the licence holder to be removed.
 - 7) *Application of Notice to Declared Fisheries Reserve*
This notice applies to the Fisheries (Declaration of Grassy Point Aquaculture Fisheries Reserve) Order 2003.
 - 8) *Revocation*
Unless sooner revoked, this fisheries notice will be revoked on the first to occur of the following:
 - a) the declaration of a management plan including the Grassy Point Aquaculture Fisheries Reserve; or
 - b) 12 months after the day on which this fisheries notice comes into force.
-

Fisheries Act 1995

FISHERIES NOTICE NO. 6/2004

I, Bob Cameron, Minister for Agriculture, after consultation with the Aquaculture Committee of the Fisheries Co-Management Council and the Victorian Aquaculture Council make the following Fisheries Notice:

Dated 24 March 2004

BOB CAMERON

Minister for Agriculture

**Aquaculture (Crown Land) Licence and Aquaculture (Crown Land) Type A Licence
Western Port/Port Phillip Bay**

1) *Title*

This notice may be cited as the Bates Point Aquaculture Fisheries Reserve Notice No. 6/2004.

2) *Objective*

The objective of this notice is to specify a measure for the protection of Aquaculture in Western Port/Port Phillip Bay as set out in paragraph 6 of this notice.

3) *Definitions*

“Bates Point Aquaculture Fisheries Reserve” otherwise referred to in this Notice as ‘the Reserve’, means the area of Western Port/Port Phillip Bay which is defined by the following co-ordinates:

	Datum AMG 66 (Degrees and decimal minutes)	
	Latitude South	Longitude East
North West	38° 05.541’	144° 27.224’
North East	38° 05.549’	144° 27.566’
South West	38° 05.812’	144° 27.215’
South East	38° 05.819’	144° 27.557’

4) *Authorising provision*

This notice is made under section 152(1)(f) of the **Fisheries Act 1995**.

5) *Commencement*

This notice comes into operation on the day on which it is published in the Victoria Government Gazette.

6) *Measure*

a) An Aquaculture (Crown Land) Licence or an Aquaculture (Crown Land) Type A Licence issued, varied or transferred after the commencement of this notice shall not specify a site within the Bates Point Aquaculture Fisheries Reserve to authorise aquaculture activities.

b) Clause 6 will not operate to prevent a licence or licences from being issued, varied or transferred where:

iii) an Aquaculture (Crown Land) Licence or an Aquaculture (Crown Land) Type A Licence which specifies a site or sites within the Reserve is surrendered and

(1) an Aquaculture (Crown Land) Licence or an Aquaculture (Crown Land) Type A Licence is issued which specifies the same site or sites within the Reserve as in the surrendered licence; or

(2) an Aquaculture (Crown Land) Licence or an Aquaculture (Crown

Land) Type A Licence which specifies a site or sites within the Reserve is varied to include a site or sites within the Reserve that are specified in the surrendered licence;

- i) an Aquaculture (Crown Land) Licence or an Aquaculture (Crown Land) Type A Licence which specifies a site or sites within the Reserve is varied or transferred and the same site or sites within the Reserve are specified in the varied or transferred licence, unless one or more of the sites have been sought by the licence holder to be removed.

7) *Application of Notice to Declared Fisheries Reserve*

This notice applies to the Fisheries (Declaration of Bates Point Aquaculture Fisheries Reserve) Order 2003.

8) *Revocation*

Unless sooner revoked, this fisheries notice will be revoked on the first to occur of the following:

- a) the declaration of a management plan including the Bates Point Aquaculture Fisheries Reserve; or
 - b) 12 months after the day on which this fisheries notice comes into force.
-

Fisheries Act 1995

FISHERIES NOTICE NO. 7/2004

I, Bob Cameron, Minister for Agriculture, after consultation with the Aquaculture Committee of the Fisheries Co-Management Council and the Victorian Aquaculture Council make the following Fisheries Notice:

Dated 24 March 2004

BOB CAMERON

Minister for Agriculture

**Aquaculture (Crown Land) Licence and Aquaculture (Crown Land) Type A Licence
Western Port/Port Phillip Bay**

1) *Title*

This notice may be cited as the Kirk Point — Werribee Aquaculture Fisheries Reserve Notice No. 7/2004.

2) *Objective*

The objective of this notice is to specify a measure for the protection of Aquaculture in Western Port/Port Phillip Bay as set out in paragraph 6 of this notice.

3) *Definitions*

“Kirk Point — Werribee Aquaculture Fisheries Reserve” otherwise referred to in this Notice as ‘the Reserve’, means the area of Western Port/Port Phillip Bay which is defined by the following co-ordinates:

Datum AMG 66 (Degrees and decimal minutes)		
	Latitude South	Longitude East
North West	38° 03.080’	144° 37.900’
North East	38° 03.097’	144° 39.240’
South West	38° 03.631’	144° 37.888’
South East	38° 03.648’	144° 39.228’

4) *Authorising provision*

This notice is made under section 152(1)(f) of the **Fisheries Act 1995**.

5) *Commencement*

This notice comes into operation on the day on which it is published in the Victoria Government Gazette.

6) *Measure*

- a) An Aquaculture (Crown Land) Licence or an Aquaculture (Crown Land) Type A Licence issued, varied or transferred after the commencement of this notice shall not specify a site within the Kirk Point — Werribee Aquaculture Fisheries Reserve to authorise aquaculture activities.
- b) Clause 6 will not operate to prevent a licence or licences from being issued, varied or transferred where:
- iv) an Aquaculture (Crown Land) Licence or an Aquaculture (Crown Land) Type A Licence which specifies a site or sites within the Reserve is surrendered and
- (1) an Aquaculture (Crown Land) Licence or an Aquaculture (Crown Land) Type A Licence is issued which specifies the same site or sites within the Reserve as in the surrendered licence; or

-
- (2) an Aquaculture (Crown Land) Licence or an Aquaculture (Crown Land) Type A Licence which specifies a site or sites within the Reserve is varied to include a site or sites within the Reserve that are specified in the surrendered licence;
 - i) an Aquaculture (Crown Land) Licence or an Aquaculture (Crown Land) Type A Licence which specifies a site or sites within the Reserve is varied or transferred and the same site or sites within the Reserve are specified in the varied or transferred licence, unless one or more of the sites have been sought by the licence holder to be removed.
- 7) *Application of Notice to Declared Fisheries Reserve*
This notice applies to the Fisheries (Declaration of Kirk Point — Werribee Aquaculture Fisheries Reserve) Order 2003.
- 8) *Revocation*
Unless sooner revoked, this fisheries notice will be revoked on the first to occur of the following:
- a) the declaration of a management plan including the Kirk Point — Werribee Aquaculture Fisheries Reserve; or
 - b) 12 months after the day on which this fisheries notice comes into force.
-

Fisheries Act 1995

FISHERIES NOTICE NO. 8/2004

I, Bob Cameron, Minister for Agriculture, after consultation with the Aquaculture Committee of the Fisheries Co-Management Council and the Victorian Aquaculture Council make the following Fisheries Notice:

Dated 24 March 2004

BOB CAMERON

Minister for Agriculture

**Aquaculture (Crown Land) Licence and Aquaculture (Crown Land) Type A Licence
Western Port/Port Phillip Bay**

1) *Title*

This notice may be cited as the Dromana Aquaculture Fisheries Reserve Notice No. 8/2004.

2) *Objective*

The objective of this notice is to specify a measure for the protection of Aquaculture in Western Port/Port Phillip Bay as set out in paragraph 6 of this notice.

3) *Definitions*

“Dromana Aquaculture Fisheries Reserve” otherwise referred to in this Notice as ‘the Reserve’, means the area of Western Port/Port Phillip Bay which is defined by the following co-ordinates:

	Datum AMG 66 (Degrees and decimal minutes)	
	Latitude South	Longitude East
North West	38° 18.277'	144° 58.250'
North East	38° 18.282'	144° 58.556'
South West	38° 18.518'	144° 58.243'
South East	38° 18.524'	144° 58.550'

4) *Authorising provision*

This notice is made under section 152(1)(f) of the **Fisheries Act 1995**.

5) *Commencement*

This notice comes into operation on the day on which it is published in the Victoria Government Gazette.

6) *Measure*

a) An Aquaculture (Crown Land) Licence or an Aquaculture (Crown Land) Type A Licence issued, varied or transferred after the commencement of this notice shall not specify a site within the Dromana Aquaculture Fisheries Reserve to authorise aquaculture activities.

b) Clause 6 will not operate to prevent a licence or licences from being issued, varied or transferred where:

v) an Aquaculture (Crown Land) Licence or an Aquaculture (Crown Land) Type A Licence which specifies a site or sites within the Reserve is surrendered and

(1) an Aquaculture (Crown Land) Licence or an Aquaculture (Crown Land) Type A Licence is issued which specifies the same site or sites within the Reserve as in the surrendered licence; or

(2) an Aquaculture (Crown Land) Licence or an Aquaculture (Crown

Land) Type A Licence which specifies a site or sites within the Reserve is varied to include a site or sites within the Reserve that are specified in the surrendered licence;

- i) an Aquaculture (Crown Land) Licence or an Aquaculture (Crown Land) Type A Licence which specifies a site or sites within the Reserve is varied or transferred and the same site or sites within the Reserve are specified in the varied or transferred licence, unless one or more of the sites have been sought by the licence holder to be removed.

7) *Application of Notice to Declared Fisheries Reserve*

This notice applies to the Fisheries (Declaration of Dromana Aquaculture Fisheries Reserve) Order 2003.

8) *Revocation*

Unless sooner revoked, this fisheries notice will be revoked on the first to occur of the following:

- a) the declaration of a management plan including the Dromana Aquaculture Fisheries Reserve; or
 - b) 12 months after the day on which this fisheries notice comes into force.
-

Fisheries Act 1995

FISHERIES NOTICE NO. 9/2004

I, Bob Cameron, Minister for Agriculture, after consultation with the Aquaculture Committee of the Fisheries Co-Management Council and the Victorian Aquaculture Council make the following Fisheries Notice:

Dated 24 March 2004

BOB CAMERON

Minister for Agriculture

**Aquaculture (Crown Land) Licence and Aquaculture (Crown Land) Type A Licence
Western Port/Port Phillip Bay**

1) *Title*

This notice may be cited as the Mount Martha Aquaculture Fisheries Reserve Notice No. 9/2004.

2) *Objective*

The objective of this notice is to specify a measure for the protection of Aquaculture in Western Port/Port Phillip Bay as set out in paragraph 6 of this notice.

3) *Definitions*

“Mount Martha Aquaculture Fisheries Reserve” otherwise referred to in this Notice as ‘the Reserve’, means the area of Western Port/Port Phillip Bay which is defined by the following co-ordinates:

	Datum AMG 66 (Degrees and decimal minutes)	
	Latitude South	Longitude East
North West	38° 13.999'	144° 59.838'
North East	38° 14.018'	145° 00.980'
South West	38° 14.485'	144° 59.824'
South East	38° 14.505'	145° 00.967'

4) *Authorising provision*

This notice is made under section 152(1)(f) of the **Fisheries Act 1995**.

5) *Commencement*

This notice comes into operation on the day on which it is published in the Victoria Government Gazette.

6) *Measure*

a) An Aquaculture (Crown Land) Licence or an Aquaculture (Crown Land) Type A Licence issued, varied or transferred after the commencement of this notice shall not specify a site within the Mount Martha Aquaculture Fisheries Reserve to authorise aquaculture activities.

b) Clause 6 will not operate to prevent a licence or licences from being issued, varied or transferred where:

vi) an Aquaculture (Crown Land) Licence or an Aquaculture (Crown Land) Type A Licence which specifies a site or sites within the Reserve is surrendered and

(1) an Aquaculture (Crown Land) Licence or an Aquaculture (Crown Land) Type A Licence is issued which specifies the same site or sites within the Reserve as in the surrendered licence; or

(2) an Aquaculture (Crown Land) Licence or an Aquaculture (Crown

Land) Type A Licence which specifies a site or sites within the Reserve is varied to include a site or sites within the Reserve that are specified in the surrendered licence;

- i) an Aquaculture (Crown Land) Licence or an Aquaculture (Crown Land) Type A Licence which specifies a site or sites within the Reserve is varied or transferred and the same site or sites within the Reserve are specified in the varied or transferred licence, unless one or more of the sites have been sought by the licence holder to be removed.

7) *Application of Notice to Declared Fisheries Reserve*

This notice applies to the Fisheries (Declaration of Mount Martha Aquaculture Fisheries Reserve) Order 2003.

8) *Revocation*

Unless sooner revoked, this fisheries notice will be revoked on the first to occur of the following:

- a) the declaration of a management plan including the Mount Martha Aquaculture Fisheries Reserve; or
 - b) 12 months after the day on which this fisheries notice comes into force.
-

Fisheries Act 1995

FISHERIES NOTICE NO. 10/2004

I, Bob Cameron, Minister for Agriculture, after consultation with the Aquaculture Committee of the Fisheries Co-Management Council and the Victorian Aquaculture Council make the following Fisheries Notice:

Dated 24 March 2004

BOB CAMERON

Minister for Agriculture

**Aquaculture (Crown Land) Licence and Aquaculture (Crown Land) Type A Licence
Western Port/Port Phillip Bay**

1) *Title*

This notice may be cited as the Beaumaris Aquaculture Fisheries Reserve Notice No. 10/2004.

2) *Objective*

The objective of this notice is to specify a measure for the protection of Aquaculture in Western Port/Port Phillip Bay as set out in paragraph 6 of this notice.

3) *Definitions*

“Beaumaris Aquaculture Fisheries Reserve” otherwise referred to in this Notice as ‘the Reserve’, means the area of Western Port/Port Phillip Bay which is defined by the following co-ordinates:

	Datum AMG 66 (Degrees and decimal minutes)	
	Latitude South	Longitude East
North West	37° 59.783’	145° 02.683’
North East	37° 59.789’	145° 03.025’
South West	38° 00.053’	145° 02.676’
South East	38° 00.059’	145° 03.018’

4) *Authorising provision*

This notice is made under section 152(1)(f) of the **Fisheries Act 1995**.

5) *Commencement*

This notice comes into operation on the day on which it is published in the Victoria Government Gazette.

6) *Measure*

a) An Aquaculture (Crown Land) Licence or an Aquaculture (Crown Land) Type A Licence issued, varied or transferred after the commencement of this notice shall not specify a site within the Beaumaris Aquaculture Fisheries Reserve to authorise aquaculture activities.

b) Clause 6 will not operate to prevent a licence or licences from being issued, varied or transferred where:

vii) an Aquaculture (Crown Land) Licence or an Aquaculture (Crown Land) Type A Licence which specifies a site or sites within the Reserve is surrendered and

(1) an Aquaculture (Crown Land) Licence or an Aquaculture (Crown Land) Type A Licence is issued which specifies the same site or sites within the Reserve as in the surrendered licence; or

(2) an Aquaculture (Crown Land) Licence or an Aquaculture (Crown

Land) Type A Licence which specifies a site or sites within the Reserve is varied to include a site or sites within the Reserve that are specified in the surrendered licence;

- i) an Aquaculture (Crown Land) Licence or an Aquaculture (Crown Land) Type A Licence which specifies a site or sites within the Reserve is varied or transferred and the same site or sites within the Reserve are specified in the varied or transferred licence, unless one or more of the sites have been sought by the licence holder to be removed.

7) *Application of Notice to Declared Fisheries Reserve*

This notice applies to the Fisheries (Declaration of Beaumaris Aquaculture Fisheries Reserve) Order 2003.

8) *Revocation*

Unless sooner revoked, this fisheries notice will be revoked on the first to occur of the following:

- a) the declaration of a management plan including the Beaumaris Aquaculture Fisheries Reserve; or
 - b) 12 months after the day on which this fisheries notice comes into force.
-

Fisheries Act 1995

FISHERIES NOTICE NO. 11/2004

I, Bob Cameron, Minister for Agriculture, after consultation with the Aquaculture Committee of the Fisheries Co-Management Council and the Victorian Aquaculture Council make the following Fisheries Notice:

Dated 24 March 2004

BOB CAMERON

Minister for Agriculture

**Aquaculture (Crown Land) Licence and Aquaculture (Crown Land) Type A Licence
Western Port/Port Phillip Bay**

1) *Title*

This notice may be cited as the Flinders Aquaculture Fisheries Reserve Notice No. 11/2004.

2) *Objective*

The objective of this notice is to specify a measure for the protection of Aquaculture in Western Port/Port Phillip Bay as set out in paragraph 6 of this notice.

3) *Definitions*

Flinders Aquaculture Fisheries Reserve” otherwise referred to in this Notice as ‘the Reserve’, means the area of Western Port/Port Phillip Bay which is defined by the following co-ordinates:

Datum AMG 66 (Degrees and decimal minutes)		
	Latitude South	Longitude East
North West	38° 26.658’	144° 03.532’
North East	38° 27.316’	144° 04.363’
E*	38° 27.327’	144° 03.007’
F*	38° 27.214’	144° 02.773’
South West	38° 28.133’	144° 02.050’
South East	38° 28.399’	144° 02.506’

* Note: E and F are bends on the western boundary of the Flinders Aquaculture Fisheries Reserve.

4) *Authorising provision*

This notice is made under section 152(1)(f) of the **Fisheries Act 1995**.

5) *Commencement*

This notice comes into operation on the day on which it is published in the Victoria Government Gazette.

6) *Measure*

a) An Aquaculture (Crown Land) Licence or an Aquaculture (Crown Land) Type A Licence issued, varied or transferred after the commencement of this notice shall not specify a site within the Flinders Aquaculture Fisheries Reserve to authorise aquaculture activities.

b) Clause 6 will not operate to prevent a licence or licences from being issued, varied or transferred where:

viii) an Aquaculture (Crown Land) Licence or an Aquaculture (Crown Land) Type A Licence which specifies a site or sites within the Reserve is surrendered and

-
- (1) an Aquaculture (Crown Land) Licence or an Aquaculture (Crown Land) Type A Licence is issued which specifies the same site or sites within the Reserve as in the surrendered licence; or
 - (2) an Aquaculture (Crown Land) Licence or an Aquaculture (Crown Land) Type A Licence which specifies a site or sites within the Reserve is varied to include a site or sites within the Reserve that are specified in the surrendered licence;
- i) an Aquaculture (Crown Land) Licence or an Aquaculture (Crown Land) Type A Licence which specifies a site or sites within the Reserve is varied or transferred and the same site or sites within the Reserve are specified in the varied or transferred licence, unless one or more of the sites have been sought by the licence holder to be removed.
- 7) *Application of Notice to Declared Fisheries Reserve*
This notice applies to the Fisheries (Declaration of Flinders Aquaculture Fisheries Reserve) Order 2003.
- 8) *Revocation*
Unless sooner revoked, this fisheries notice will be revoked on the first to occur of the following:
- a) the declaration of a management plan including the Flinders Aquaculture Fisheries Reserve; or
 - b) 12 months after the day on which this fisheries notice comes into force
-

Petroleum Act 1998

STATE OF VICTORIA

Notice of Invitation of Application for
Onshore Murray Basins Petroleum Exploration Permits

Applications are invited for the grant of Petroleum Exploration Permits under section 19 of the **Petroleum Act 1998** in respect of the three (3) onshore areas in the Murray Basin, in the State of Victoria, to be referred to as VIC/M-04 (1), VIC/M-04 (2) and VIC/M-04 (3).

DESCRIPTION OF AREAS**SCHEDULE**

(The references hereunder are to the names of map sheets of 1:100,000 series and to the numbers of the graticular sections shown thereon.
All maps referred to are in the AGD66 datum).

Area VIC/M-04 (1)**Murray Basin, Victoria**

Map Sheet SI 54 (Adelaide)

1841(part)	1842(part)	1843(part)	1844(part)	1845(part)	1846(part)
1847(part)	1848(part)	1912	1913	1914(part)	1915(part)
1916(part)	1917	1918	1919	1920	1984
1985	1986	1987	1988	1989	1990
1991	1992	2056	2057	2058	2059
2060	2061	2062	2063	2064	2128
2129	2130	2131	2132	2133	2134
2135	2136				

Assessed to contain 44 blocks.

Area VIC/M-04 (2)**Murray Basin, Victoria**

Map Sheet SI 54 (Adelaide)

2948 (part)	2949(part)	2950(part)	3020	3021	3022(part)
3023(part)	3092	3093	3094	3095(part)	3096(part)
3164	3165	3166	3167	3168	3236
3237	3238	3239	3240	3308	3309
3310	3311	3312	3380	3381	3383
3384	3452	3453	3455	3456	

And Continue in Map Sheet SI 55 (Canberra)

3025(part)	3097(part)	3098(part)	3169	3170(part)	3171(part)
3172(part)	3241	3242	3243	3244(part)	3313
3314	3315	3316	3385	3386	3387
3388					

And Continue in Map Sheet SJ 54 (Hamilton)

68	69	70	71	72	140
141	142	143	144		

And Continue in Map Sheet SJ 55 (Melbourne)

1	2	3	4	73	74
---	---	---	---	----	----

Assessed to contain 70 blocks.

Area VIC/M-04 (3)
Murray Basin, Victoria
Map Sheet SI 55 (Canberra)

3245(part)	3254(part)	3317(part)	3318(part)	3326(part)	3389
3390(part)	3391(part)	3397	3398		

And Continue in Map Sheet SJ 55 (Melbourne)

5	6	7(part)	8(part)	9(part)	11(part)
12(part)	13	14	77	78	79
80	81(part)	82(part)	83(part)	84	85
86	149	150	151	152	153
154	155	156	157	158	221
222	223	224	225	226	227
228	229	230	293	294	295
296	297	298	299	300	301
302	365	366	367	368	369
370	371	372	373	374	

Assessed to contain 69 blocks.

APPLICATIONS

CONDITIONS OF APPLICATION

The Minister proposes to issue Petroleum Exploration Permits under the **Petroleum Act 1998** (the Act) to the successful applicant.

Applications shall be submitted in accordance with the provisions of Part 3, Exploration Permits, and Part 7, Provisions Applying to Authorities Generally of the Act.

Full details of the proposed Exploration Program being offered and covering a period of tenure of five (5) years with listings of the key objectives of the first three (3) years of the work program, for the purpose of section 27 of the Act, must be provided.

The areas are offered without implementation of the 'right to negotiate' provisions contained in Part 2, Division 3, Subdivision B of the **Native Title Act 1993** (Cth). The offer contained in this Notice does not constitute a representation by the Crown or any of its officers or employees that the offer does not affect Native Title. The offer is invalid if it impacts on Native Title. The successful applicant will be required where appropriate, to comply with Native Title processes. Information

regarding Petroleum titles and Native Title can be found at www.dpi.vic.gov.au/minpet/ then go to 'Policy and Legislation' then 'Native Title'.

If Native Title processes are applicable, the applicant will be required to resolve Native Title issues. The Department will also require periodic progress reports with respect to these processes.

Preliminary consultation with representatives of Aboriginal people has not identified any particular Native Title interests. However, advice has been received that Native Title Claims have been registered over these advertised areas. The Claims boundaries can be viewed on the National Native Title Tribunal (NNTT) website: www.nntt.gov.au. Successful applicants will be required to consult closely with the relevant Aboriginal groups/agencies and local Aboriginal organisations.

Potential permit holders should also note that:

- before conducting any exploration activities they must make themselves familiar with (and refer to) the Victorian **Petroleum Act 1998**, the **National Parks Act 1975**, **Wildlife Act 1975** and **Flora and Fauna Guarantee Act 1988**;
- they are to contact Parks Victoria, the Department of Sustainability and Environment (DSE) to obtain their views on proposed fieldwork to alleviate possible adverse impact on wetlands, native grasslands, threatened plant communities, rare and threatened flora and fauna species;
- they are not to carry out exploration work in Murray River Reserve;
- they are to contact Heritage Services of the Department for Victorian Communities for consultation with Regional Cultural Heritage Program managers. Information on relevant Aboriginal Regional Cultural Heritage Program Regions can be viewed on Aboriginal Affairs Victoria website: www.dvc.vic.gov.au; and
- to contact local Aboriginal Communities responsible for cultural heritage matters within their particular community boundaries before commencing operations in accordance with section 146 of the Act.

SELECTION CRITERIA

Full details of the proposed exploration program being offered and covering a period of tenure of five (5) years must be provided. The factors that will be considered in assessing applications will be the key objects of the work program for the first three (3) years of the five-year term, and the financial and technical resources available to the applicant. Applicants should note in particular, sections 18–27 and 96–99 of the Act.

Further details of the work program bidding system, mentioned above, including the criteria for assessment of applications and the conditions to apply following the award of the permit are available by visiting the Department's website: <http://www.dpi.vic.gov.au/minpet/> or from the Director Minerals and Petroleum Regulation.

LODGMET OF APPLICATIONS AND CLOSING DATE

Applications addressed to the Minister for Energy Industries and Resources together with the relevant data must be lodged by 4:00 PM (EST) on Thursday, 30 September 2004 and submitted to:

The Tender Box Manager
Department of Primary Industries
8 Nicholson Street
East Melbourne, Victoria, 3002
Attn. Senior Petroleum Tenement Officer
Minerals and Petroleum Regulation

The following special instructions should be observed:

- Two (2) copies of the application and supporting data must be submitted;
- The application should then be sealed and clearly marked 'Application for Area VIC/M-04'

() Commercial-in-Confidence’;

- This envelope or package should then be enclosed in a plain covering envelope or package and delivered by hand or posted to the address above, and marked — Attention: Senior Petroleum Tenements Officer, Minerals and Petroleum Regulation; and
- Each application must be accompanied by a fee of A\$3,000 payable to the Victorian Department of Primary Industries through an Australian bank or bank cheque.

AVAILABLE DATA

Limited basic exploration data (mainly airborne magnetics and gravity data) pertaining to the blocks comprising this Notice is available. It can be ordered from GeoScience Victoria (GSV) or by e-mailing Graeme Torr at: graeme.torr@dpi.vic.gov.au. GSV is currently located on the 7th Floor/250 Victoria Parade, East Melbourne, Victoria 3002. In early June 2004 the GSV will be relocated at 17th Floor/1 Spring Street, Melbourne, Victoria 3000.

Dated 3 April, 2004

RICHARD ALDOUS
Executive Director, Minerals and Petroleum Division
Pursuant to the Instrument of Delegation

Petroleum (Submerged Lands) Act 1982

STATE OF VICTORIA

Notice of Invitation of Application for Exploration Permits

Applications are hereby invited for the grant of Petroleum Exploration Permits under Section 20(1) of the **Petroleum (Submerged Lands) Act 1982** of the State of Victoria in respect of the following blocks within the areas as described in the following schedule.

SCHEDULE

(The reference hereunder is to the name of map sheet of 1:100,000 series and to the numbers of the graticular sections shown thereon).

Otway Basin, Victoria**Area 04-1(v)**

Map Sheet SJ 54 (Hamilton)

1764 part	1765 part	1836 part	1837 part	1838 part	1839 part
1910 part	1911 part	1912 part	1983 part	1984 part	1985 part

Assessed to contain 12 blocks

APPLICATIONS

Applications lodged under Section 20 of the **Petroleum (Submerged Lands) Act 1982** are required to be made in the approved form and should be accompanied by:

- (a) Details of —
- (i) the applicant's technical assessment of the petroleum potential of the area, including the concepts underlying its proposed exploration program, with sufficient detail to support that program;
 - (ii) the applicant's minimum guaranteed proposal (including indicative minimum expenditure) for exploration wells to be drilled, 3D and 2D seismic and other surveying activities, data evaluation and other work, for each year of the first three years of the permit term. This proposal, to be known as the minimum guaranteed work program, should comprise work expected to involve a substantial exploration component — normally, appraisal work should not be included;
 - (iii) the applicant's proposal (including indicative minimum expenditure) for exploration wells to be drilled, 3D and 2D seismic and other surveying activities, data evaluation and other work, for each of the three remaining years of the permit term. This proposal, to be known as the secondary work program, should comprise work expected to involve a substantial exploration component — normally, appraisal work should not be included.
- (b) Particulars of —
- (i) the technical qualifications of the applicant and of its key employees;
 - (ii) the technical advice available to the applicant;
 - (iii) the financial resources available to the applicant, including evidence of the applicant's ability to fund the work program proposed, a statement of other exploration commitments over the next six years, and a copy of the latest annual report and quarterly reports for each applicant company;
 - (iv) where relevant, the viability of the consortium lodging the application, including evidence that a satisfactory settlement has been, or can be, reached on the Joint Operating Agreement (a copy of a signed Heads of Agreement Dealing will generally suffice); and
 - (v) the percentage participation interest of each party to the application.
- (c) Such other information as the applicant wishes to be taken into account in consideration of the application.

- (d) Each application must be accompanied by a fee of A\$3,900, payable to the Department of Primary Industries through an Australian bank or bank cheque.

Further details of the work program bidding system mentioned above, including the criteria for assessment of applications and the conditions to apply following the award of the permit, are available on the DPI website: www.dpi.vic.gov.au/minpet/

A schedule of Special Requirements is appended to the end of this Notice. The figure included in the Special Requirements Schedule shows the released areas prepared based on AGD66 Datum.

While several of the Requirements related to the State Waters areas exclusively, they may be applied to the Adjacent Commonwealth release because of common boundaries. More detail on environmental issues can be obtained from Geoff Collins, Ph: 03 94125095, e-mail: geoff.collins@dpi.vic.gov.au.

Availability of Data

Available basic exploration data pertaining to the block comprising this notice can be purchased from GeoScience Victoria (GSV) or ordered by e-mail from Graeme Torr at:

graeme.torr@dpi.vic.gov.au. GSV is located on the 7th Floor/250 Victoria Parade, East Melbourne, Victoria 3002 till approximately early June 2004; after that GSV will be relocated at 17th Floor/1 Spring Street, Melbourne, Victoria 3000.

Closing Dates and Lodgment of Applications

Applications must be lodged by 4:00 PM (EST) on Thursday 30 September 2004 and submitted to:

The Tender Box Manager
Department of Primary Industries
8 Nicholson Street
East Melbourne, Victoria, 3002
Attn. Senior Petroleum Tenement Officer
Minerals and Petroleum

The following special instructions should be observed:

- Two copies of the application and supporting data, together with a fee of \$3,900, should be enclosed in an envelope or package.
- The application should then be sealed and clearly marked "Application for Area 04-1(v) Commercial-in-Confidence".
- This envelope or package should then be enclosed in a plain covering envelope or package and delivered by hand or posted to the relevant address above.

Made under the **Petroleum (Submerged Lands) Act 1982**

Dated 3 April 2004

PHILLIP ROBERTS
Manager, Minerals and Petroleum Regulation
Delegate of the Designated Authority

**SPECIAL REQUIREMENTS FOR ENVIRONMENTAL PROTECTION
(VICTORIAN LEGISLATION BUT COULD IMPACT AT THE JUNCTION BOUNDARY
WITH THE COMMONWEALTH RELEASE)**

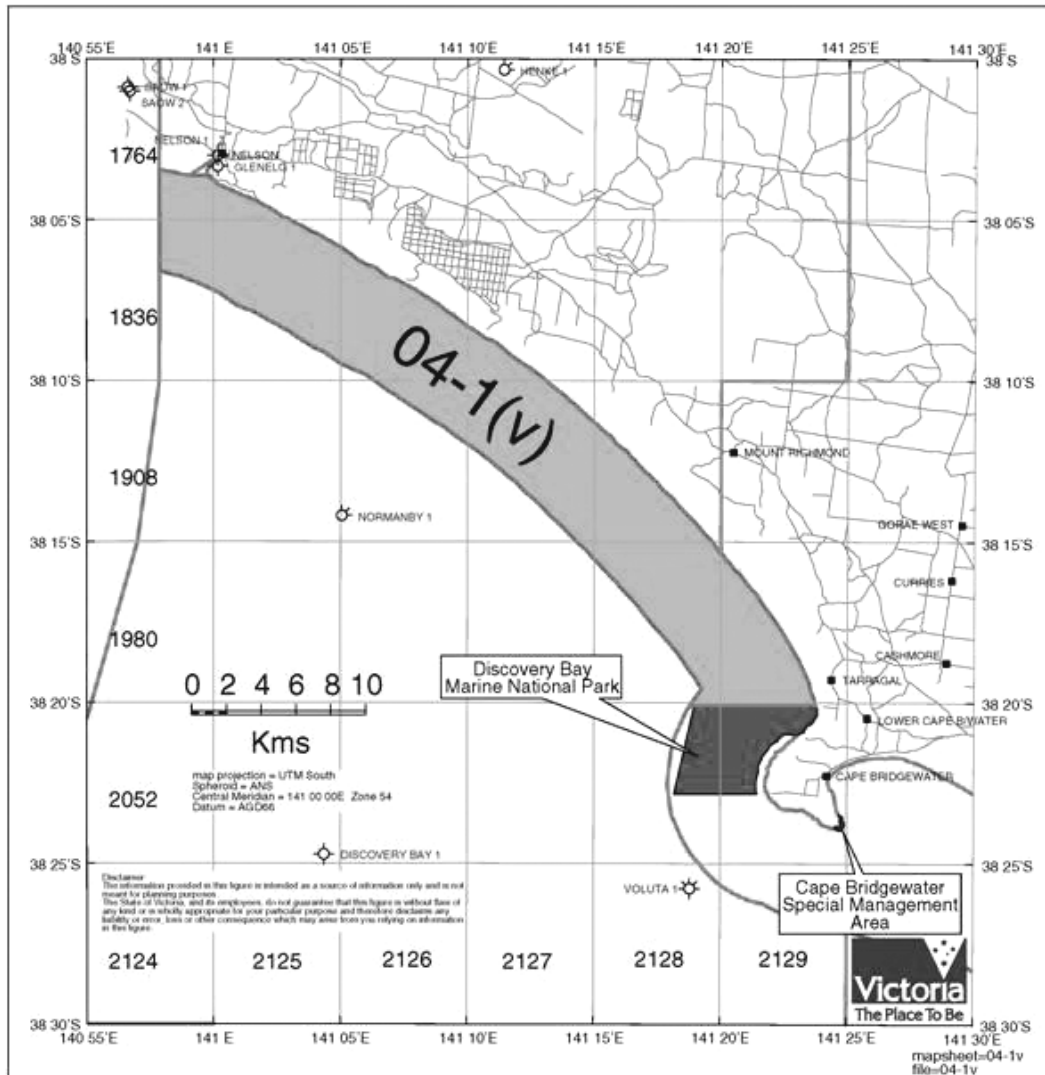

Released Near-Shore Area 04-1(v) in the Otway Basin

PROPOSED EXPLORATION PROGRAM

Should a permit be granted which requires the conduct of seismic surveys or drilling of a well, then under the requirements of the State’s **Petroleum (Submerged Lands) Act 1982** an environmental management plan is required to be submitted and approved before the commencement of the activity. Applicants are encouraged to view “Environmental Information Package for Companies Bidding on Offshore Exploration Permits in Victoria” document on DPI website: www.dpi.vic.gov.au/minpet/.

REFERRALS — ENVIRONMENT PROTECTION & BIODIVERSITY ACT

If the permit operator believes that the activity significantly impacts on a matter of national environmental significance and may need approval under the **Commonwealth Environment**

Protection & Biodiversity Act, 2000 (EPBC), a referral must be submitted to Environment Australia. The purpose of the referral is to determine whether a proposed action requires approval by the Commonwealth Environment Minister. If the Minister determines that an approval is required, then the proposed action will proceed through the assessment and approval process.

INSURANCE

Successful applicants will be required under section 97A of the **Petroleum (Submerged Lands) Act 1982** or the **Petroleum (Submerged Lands) Act 1967** to effect and maintain insurance against expenses or liabilities or specified things arising in connection with, or as a result of, the carrying out of work, or doing any other thing, under the permit, including expenses of complying with directions with respect to the clean-up or other remedying of the effects of the escape of petroleum.

NAVIGATION AND FISHERIES REQUIREMENTS

Section 124 of the **Petroleum (Submerged Lands) Act 1982** requires, inter alia, that petroleum operations be carried out in a manner that does not interfere with navigation or fishing activities.

Successful applicants are required prior to the commencement of seismic and drilling operations to ensure that:

- navigation requirements are met by maintaining regular contact with the Maritime Rescue Co-ordination Centre of the Australian Maritime Safety Authority, early and ongoing liaison to take place with commercial fishing peak bodies and recreational anglers peak bodies as well as local fishing groups and get agreement for compensation to individual fishers for any lost productivity if appropriate.
- proposed exploration activities, in accordance with normal practice, be supplemented by a Declaration of Environmental Factors and Oil Spill Contingency Plan.
- Permit holders will need to liaise with:
 - Seafood Industry Victoria (SIV) which is the peak-fishing industry representing commercial fishermen in Victoria,
 - VRFish (of this department) which is the responsible peak-body under the **Fisheries Act 1995** for recreational fishers in Victoria, and
 - Fisheries Victoria of this Department to resolve a concern by the fishing industry related to possible adverse impacts by seismic source on fish larvae close to the coast.
- Permit holders to note that DPI Queenscliff Fisheries is proposing a research to investigate the effects of seismic surveys on Southern Rock lobster and seek opportunities to support this proposal.
- V04-1 is the prime Squid fishing ground from March to July. This requires careful planning and coordination between the Squid fishing groups and seismic acquisition contractors during this season. Timing for the Squid seasons can be obtained from DPI Fisheries Victoria and from the Australian Fishing Management Authority.

HISTORIC SHIPWRECKS

Heritage Victoria has special concerns that 04-1(v) is likely to contain a number of significant wrecks.

The gazetted area is in the vicinity of remains of Historic Shipwrecks and aeroplane wrecks included on the Heritage Inventory established under the **Heritage Act 1995** and/or in some instances the **Commonwealth Historic Shipwrecks Act 1976**. The proponent permit holder must not do any work within 100m laterally of the archaeological sites and should consult with Heritage Victoria for consent to do work within 100m of such sites. Furthermore, under Sec 132 of the **Heritage Act 1995**, if a relic is discovered in the course of exploration, the permit holder must as soon as practicable report the discovery to the Executive Director, Heritage Victoria.

NATIVE TITLE

Preliminary consultation with representatives of Aboriginal people has not identified any particular interests. However, advice has been received that a Native Title Claim, No. VC99/007, over acreage 04-1(v) and on the National Native Title Tribunal (NNTT) was registered on 27/7/1997. The Claim's boundary can be viewed on the NNTT website: www.nntt.gov.au. Successful applicants will be required to consult closely with this Aboriginal group before commencing operation in this area on all heritage issues.

Petroleum (Submerged Lands) Act 1967

COMMONWEALTH OF AUSTRALIA

Notice of Invitation of Application for Exploration Permits

I, the Delegate of the Designated Authority for and on behalf of the Commonwealth–Victoria Offshore Petroleum Joint Authority, acting pursuant to Section 20(1) of the **Petroleum (Submerged Lands) Act 1967** of the Commonwealth of Australia, hereby invite applications for the grant of exploration permits in respect of the following blocks within the area as described in the following schedule.

The Commonwealth/State/Territory jurisdictional boundary in coastal waters is determined by the Australian Maritime Boundaries Information System Dataset of 2000, released in January 2001 by the Australian Surveying and Land Information Group (now part of Geoscience Australia). The block description of the areas in the 2004 release is based on this system.

Section 5AAA of the **Petroleum (Submerged Lands) Act 1967** provides that, where a change to the baseline of Australia's territorial sea would impact on the boundary of an existing petroleum title (in Commonwealth or State or Territory waters), there is in fact no such impact. The Commonwealth, State or Territory Act (as the case may be) under which the title has been granted, continues to apply to the title and the whole title area for as long as the title remains in force. Therefore, this Instrument does not apply to any such area that is already under title.

SCHEDULE

(The references hereunder are to the names of map sheets of 1:100,000 series and to the numbers of the graticular sections shown thereon).

Area V04-1**Otway Basin, Victoria**

Map Sheet SJ 54 (Hamilton)

2281	2353	2354	2355	2425	2426
2427	2428	2497	2498	2499	2500
2501	2502	2571	2572	2573	2574
2575	2645	2646	2647	2648	2718
2719	2720	2721	2791(part)	2792(part)	2793(part)

Assessed to contain 30 blocks

Area V04-2**Torquay Sub-basin, Otway Basin, Victoria**

Map Sheet SJ 54 (Hamilton)

2304(part)	2374(part)	2375(part)	2376(part)	2445(part)	2446(part)
2447	2448	2517(part)	2518	2519	2520
2589	2590	2591	2592	2661	2662
2663	2733	2734	2735	2805(part)	2806(part)
2807(part)					

And Continue in Map Sheet SJ 55 (Melbourne), Victoria

1951(part)	2020(part)	2021(part)	2022(part)	2023(part)	2024(part)
2090(part)	2091(part)	2092(part)	2093	2094	2095
2096	2161(part)	2162(part)	2163	2164	2165
2166	2167	2168	2233(part)	2234	2235
2236	2237	2238	2239	2240	2305
2306	2307	2308	2309	2310	2311
2312	2377	2378	2379	2380	2381
2382	2383	2449	2450	2451	2452
2453	2454	2521	2522	2523	2524
2525					

Assessed to contain 80 blocks

APPLICATIONS

Applications lodged under Section 20 of the **Petroleum (Submerged Lands) Act 1967** are required to be made in the approved form and should be accompanied by:

- (a) Details of —
 - (i) the applicant's technical assessment of the petroleum potential of the area, including the concepts underlying its proposed exploration program, with sufficient detail to support that program;
 - (ii) the applicant's minimum guaranteed proposal (including indicative minimum expenditure) for exploration wells to be drilled, 3D and 2D seismic and other surveying activities, data evaluation and other work, for each year of the first three years of the permit term. This proposal, to be known as the minimum guaranteed work program, should comprise work expected to involve a substantial exploration component – normally, appraisal work should not be included;
 - (iii) the applicant's proposal (including indicative minimum expenditure) for exploration wells to be drilled, 3D and 2D seismic and other surveying activities, data evaluation and other work, for each of the three remaining years of the permit term. This proposal, to be known as the secondary work program, should comprise work expected to involve a substantial exploration component — normally, appraisal work should not be included.
- (b) Particulars of —
 - (i) the technical qualifications of the applicant and of its key employees;
 - (ii) the technical advice available to the applicant;
 - (iii) the financial resources available to the applicant, including evidence of the applicant's ability to fund the work program proposed, a statement of other exploration commitments over the next six years, and a copy of the latest annual report and quarterly reports for each applicant company;
 - (iv) where relevant, the viability of the consortium lodging the application, including evidence that a satisfactory settlement has been, or can be, reached on the Joint Operating Agreement (a copy of a signed Heads of Agreement Dealing will generally suffice); and
 - (v) the percentage participation interest of each party to the application.
- (c) Such other information as the applicant wishes to be taken into account in consideration of the application.
- (d) Each application must be accompanied by a fee of A\$3,900, payable to Commonwealth of Australia through an Australian bank or bank cheque.

Further details of the work program bidding system outlined above, including the criteria for assessment of applications and the conditions to apply following the award of the permit, are available from ITR website: <http://www.industry.gov.au/resources/petroleum.html> or from DPI website: <http://www.dpi.vic.gov.au/minpet/>.

It should be noted that any income derived in the future from the recovery of petroleum from this area would be subject to the Commonwealth Government's Resource Rent Tax.

Availability of Data

Copies of the basic exploration data as well as the Department of Primary Industries' prepared prospectivity package pertaining to the blocks comprising this notice can be purchased from GeoScience Victoria (GSV) or ordered by e-mail from Graeme Torr at: graeme.torr@dpi.vic.gov.au. GSV is located on the 7th Floor/250 Victoria Parade, East Melbourne, Victoria 3002 till approximately early June 2004; after that date GSV will be relocated at 17th Floor/1 Spring Street, Melbourne, Victoria 3000.

Closing Dates and Lodgment of Applications

Applications must be lodged by 4:00 PM on Thursday 30 September 2004 for area V04-1 and Thursday 31 March 2005 for areas V04-2 and submitted to:

The Tender Box Manager
Department of Primary Industries
8 Nicholson Street
East Melbourne, Victoria, 3002
Attn. Senior Petroleum Tenement Officer
Minerals and Petroleum

The following special instructions should be observed:

- Two copies of the application and supporting data, together with the \$3,900 fee, should be enclosed in an envelope or package.
- The application should then be sealed and clearly marked "Application for Area V04-Commercial-in-Confidence".
- This envelope or package should then be enclosed in a plain covering envelope or package and delivered by hand or posted to the relevant address above.

Made under the **Petroleum (Submerged Lands) Act 1967** of the Commonwealth of Australia

Dated 3 April 2004

PHILLIP ROBERTS
Manager, Minerals and Petroleum Regulation
Delegate of the Designated Authority

Water Act 1989

FIRST MILDURA IRRIGATION TRUST

Excision of Land from Trust District

Pursuant to Section 104 Parts (1) and (2) of the **Water Act 1989**, notice is hereby given of the intention to excise the following land lots as detailed in the plans below.

Corner 15th Street & Deakin Avenue, Mildura

Subdivision	Plan No.	Lots
	PS 440752U Ver 4	Lots 1 & 2

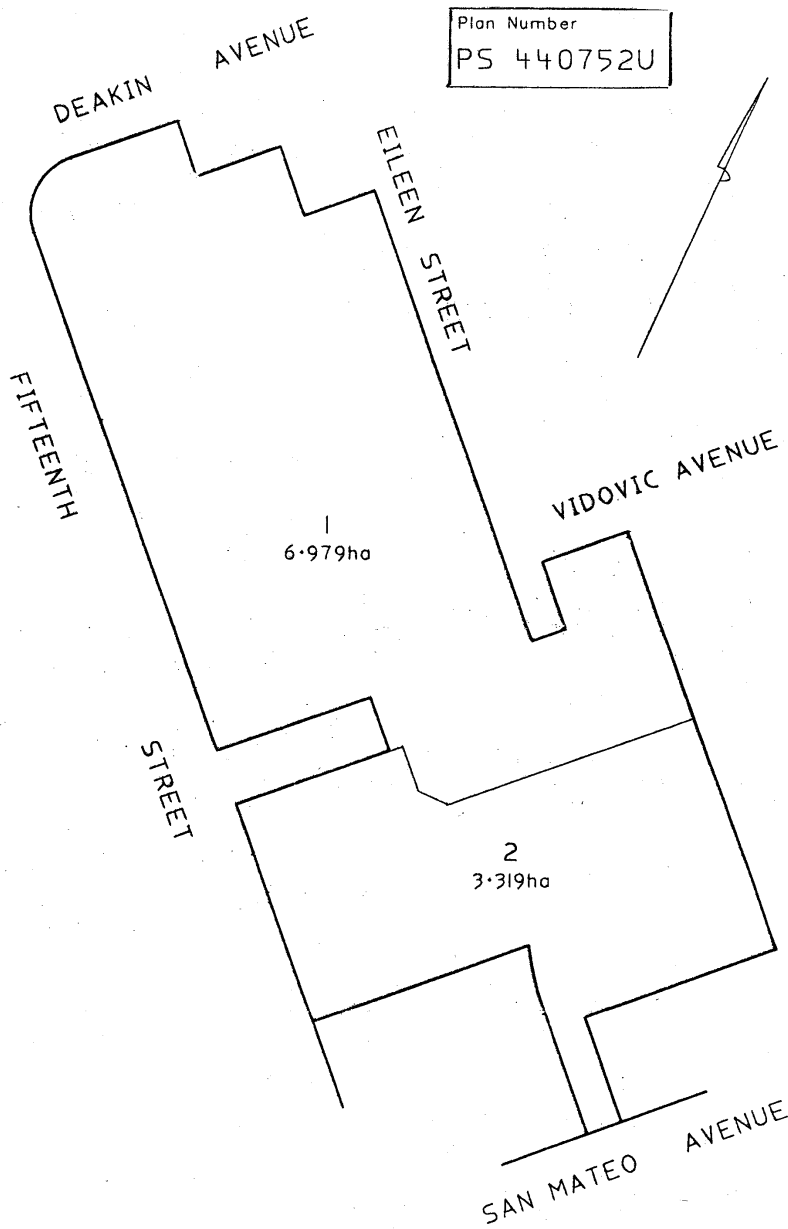

Richcorp Developments & DMcK Developments Pty Ltd
Karadoc Avenue & Francesca Drive, Irymple

Subdivision

Plan No.

Lots

PS 500325J Ver 2

1-43

PS 500325J

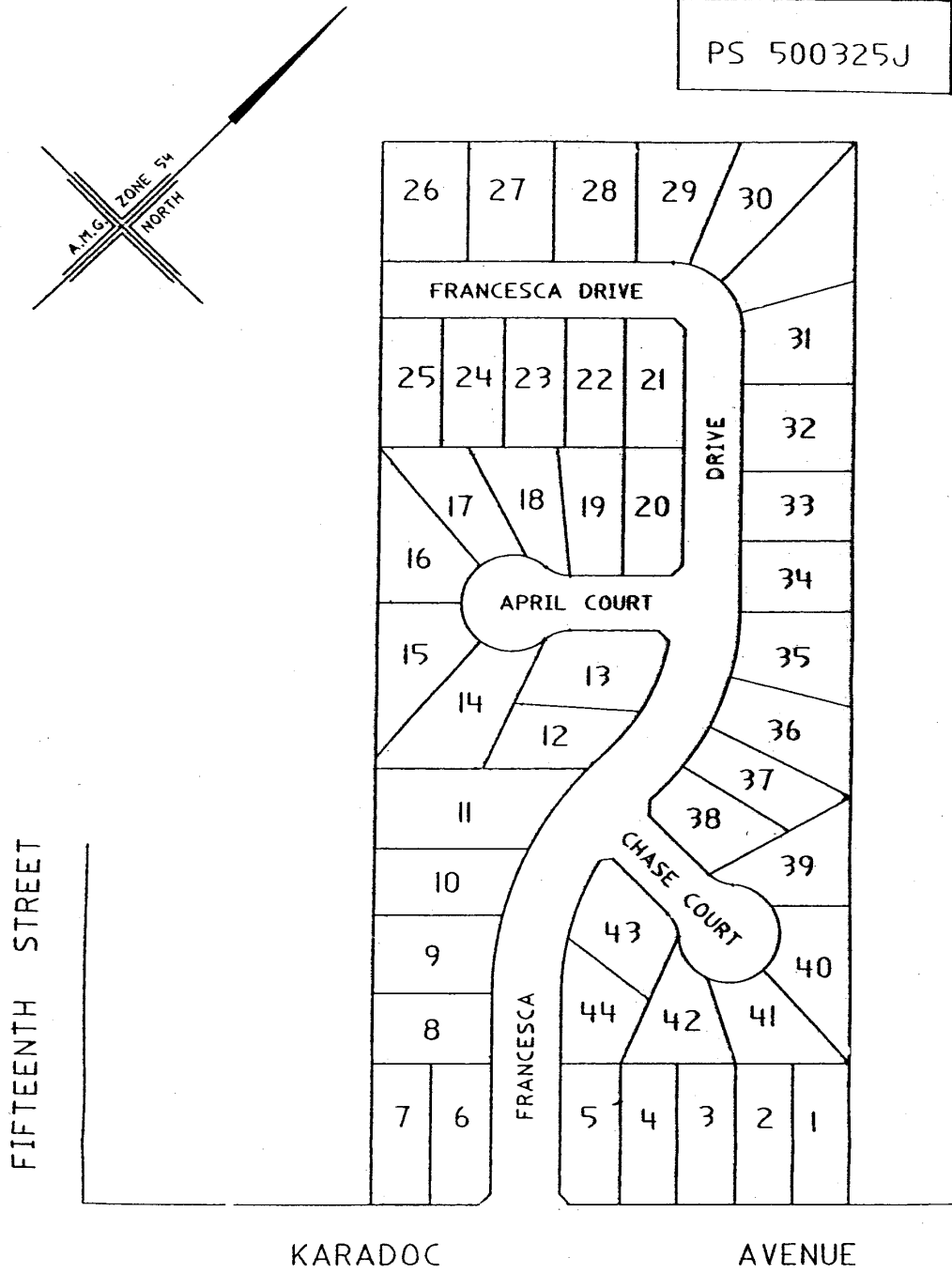

Alessi F & T – Alessi Rise
San Mateo Avenue, Mildura South

Subdivision

Plan No.

Lots

PS 507100W Ver 5

Lots 1–11 & 36–41 Stage 1

PS 509528U Ver 2

Lots 12–35 – Stage 2

PS 507100W
PS 509528U

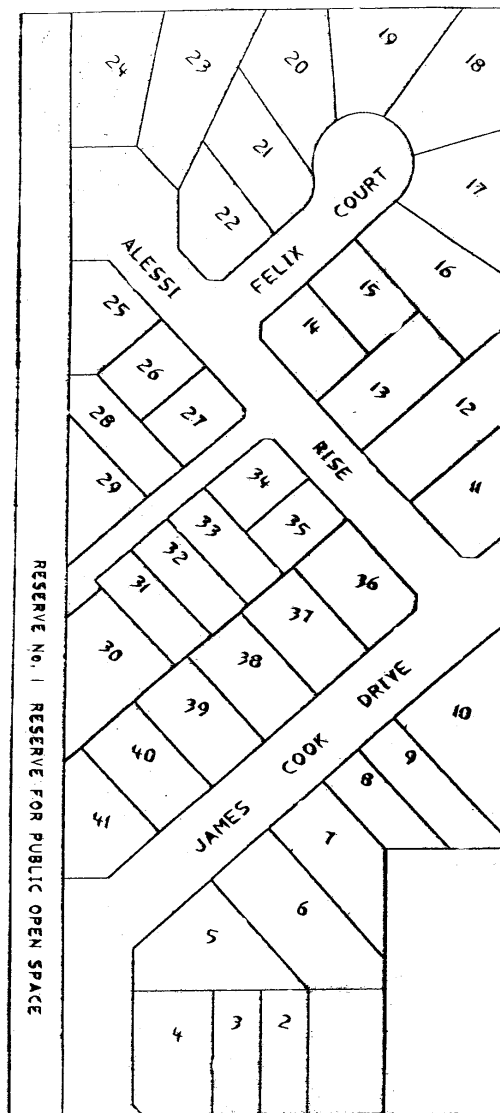

SAN MATEO AVENUE

Villiva Drive – Dyar Avenue, Mildura
Petrucci Investments

Subdivision

Plan No.
PS 505005B Ver 3

Lots
Lots 166–178 & 223–228
Stage 1

Stage No.	Plan Number
1	PS 505005B



Belar Avenue & Cureton Avenue

Subdivision

Plan No.

Lots

PS 429215M Ver 4

Lots 1, 2 & 3

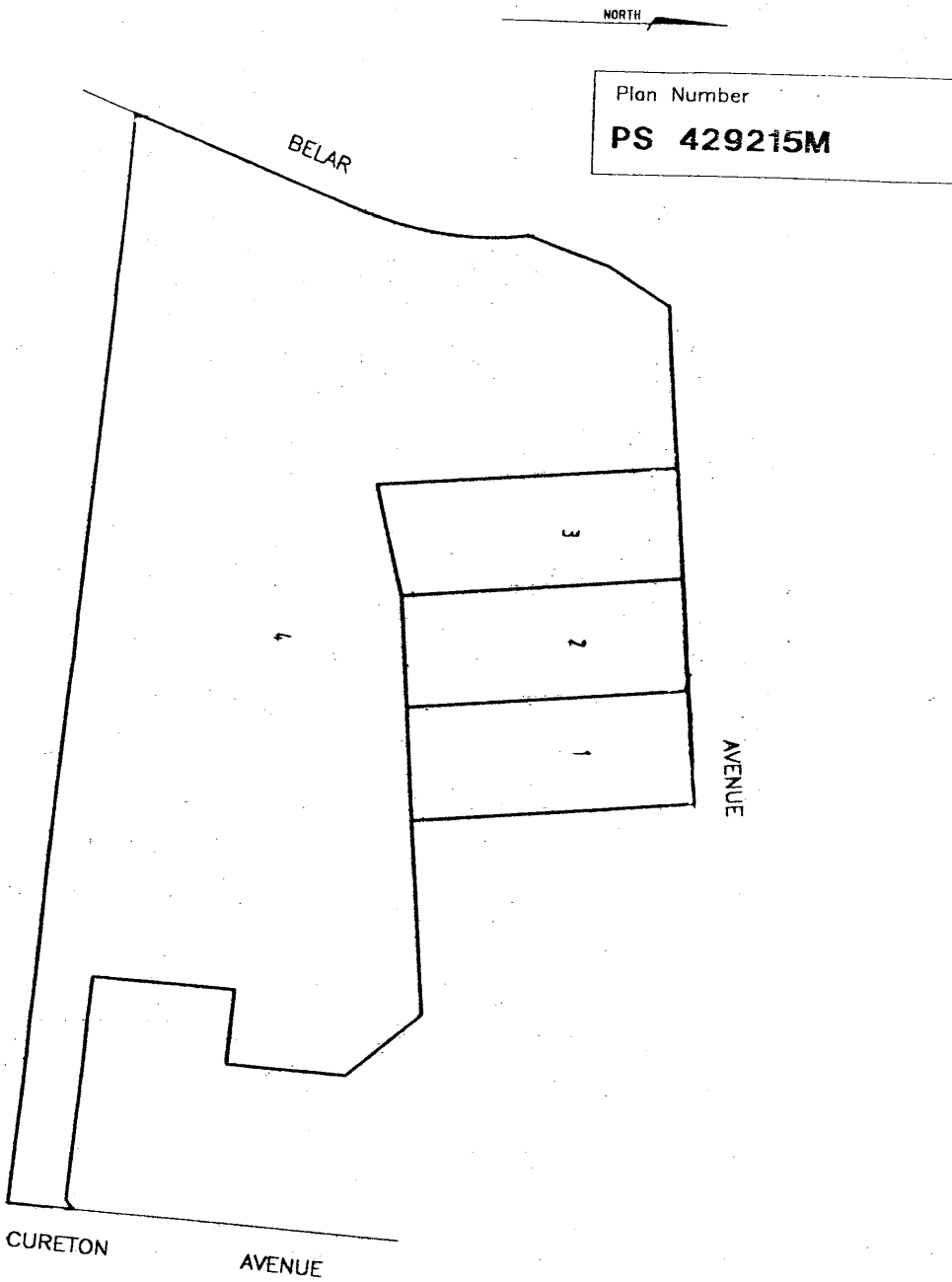

Koorlong Avenue, Irymple

Subdivision

Plan No.

Lots

PS 436046T Ver 43

Lots 1 & 2 Common Property

Plan Number
PS 436046T

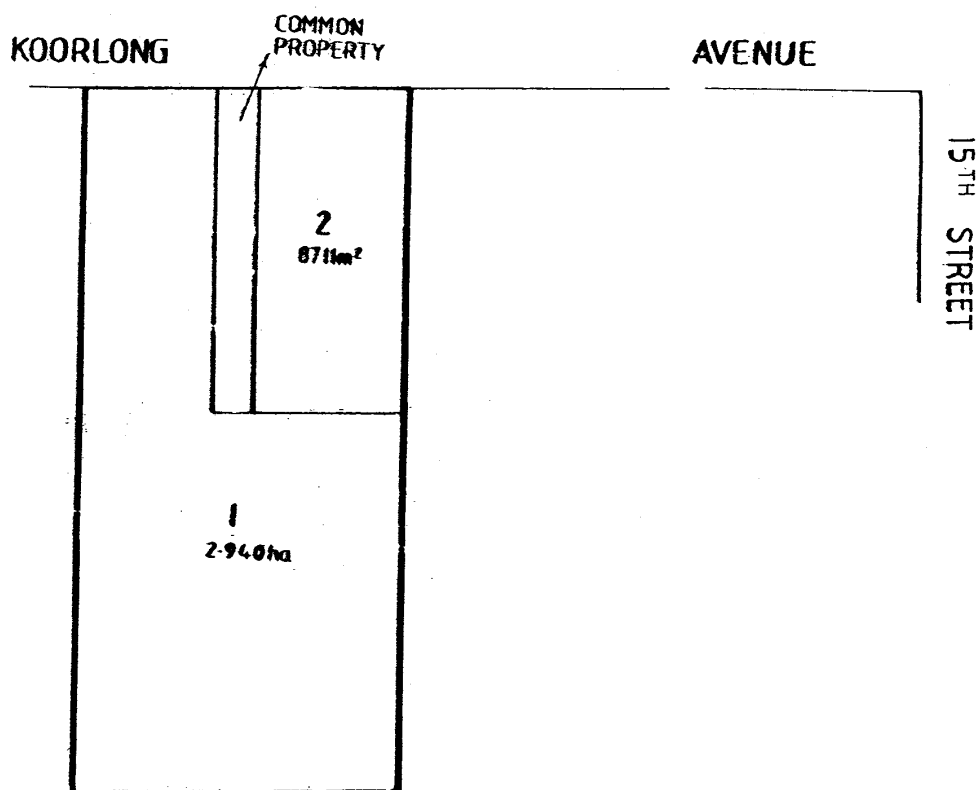

Industrial Drive/Benetook Avenue/Cureton Avenue

Subdivision	Plan No.	Lots
	PS 505003F Ver 2	Lots 1-3 & 9-11 & Reserve No. 1
	PS 505004D Ver 2	Lots 4-8 & 12-16

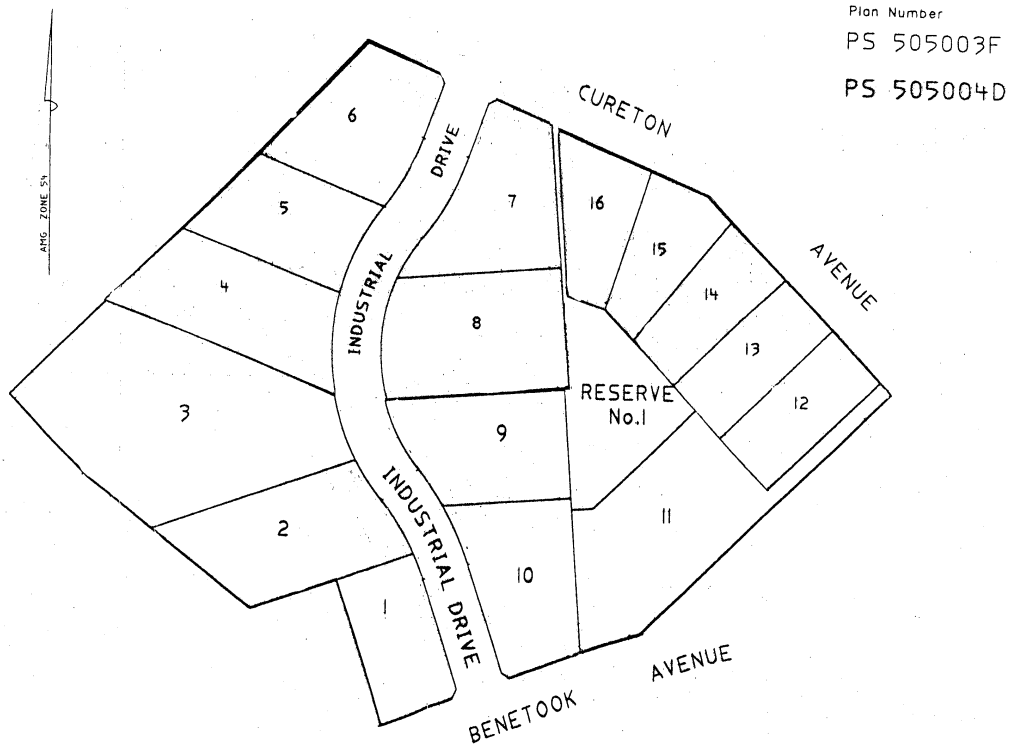

Any person who believes that they may be affected by the proposed excisions may lodge an objection in relation to excisions.

Written submissions setting out grounds for objection must be received by the Trust within 4 weeks of the publication of this notice.

The boundaries of the said excised lots as per survey are marked on plans which are available for inspection at the Trust office during working hours.

ROD RALPH
Chief Executive Officer

Private Agents Act 1966**NOTICE OF RECEIPT OF APPLICATIONS FOR LICENCES
UNDER THE PROVISIONS OF THE PRIVATE AGENTS ACT 1966**

I, the undersigned, being the Registrar of the Magistrates' Court at Melbourne hereby give notice that applications as under, have been lodged for hearing by the said Court on the date specified.

Any person desiring to object to any of such applications must:—

- (a) lodge with me a notice in the prescribed form of his objection and of the grounds thereof;
- (b) cause a copy of such notice to be served personally or by post upon the applicant at least three days before the hearing of the application; and
- (c) send or deliver
 - (i) where the objection is not made by the officer in charge of the police district in which the Court is situated — a copy of the notice to such officer; and
 - (ii) where the objection is not made by the Registrar or Deputy Registrar — a copy to the Registrar.

<i>Full name of Applicant or in the case of a Firm or Corporation, of the Nominee</i>	<i>Place of Abode of Applicant or Nominee</i>	<i>Name of Firm or Corporation</i>	<i>Address for Registration</i>	<i>Type of Licence</i>
Peter Lawrence Rollingson	3/6 Mulga Street, Altona 3018	Advanced Credit Management Ltd	Level 3, 63 Exhibition Street, Melbourne 3000	Commercial Sub-Agents Licence
Richard Robert Grigg	19B Gavan Street, Camberwell 3124	Accounts Receivable Management P/L	Level 2, 85 Queen Street, Melbourne 3000	Commercial Sub-Agents Licence
Katrina Leanne Elliott	18 Classic Court, Altona Meadows 3020	Receivables Management Ltd	363 King Street, Melbourne 3000	Commercial Sub-Agents Licence
Adrian Edmond Menezes	3/689 Warrigul Road, Bentleigh East 3165	Receivables Management Ltd	363 King Street, Melbourne 3000	Commercial Sub-Agents Licence
Vera Stojcevski	9 Knightsbridge Avenue, Laverton 3026	Receivables Management Ltd	363 King Street, Melbourne 3000	Commercial Sub-Agents Licence

<i>Full name of Applicant or in the case of a Firm or Corporation, of the Nominee</i>	<i>Place of Abode of Applicant or Nominee</i>	<i>Name of Firm or Corporation</i>	<i>Address for Registration</i>	<i>Type of Licence</i>
Helen Lugg	1/7 Crawford Road, Clarinda Victoria	I.V.S Mercantile	Suite 4, 145 Wattletree Road, Malvern 3144	Commercial Sub-Agents Licence

Dated at Melbourne 30 March 2004

GRAEME J. HORSBURGH
Principal Registrar
Magistrates' Court of Victoria

Occupational Health and Safety Act 1985
VICTORIAN WORKCOVER AUTHORITY
Notice of Issue of Major Hazard Licence

On 24 March 2004, a licence under Part 8 of the Occupational Health and Safety (Major Hazard Facilities) Regulations 2000 was issued to Melbourne Water Corporation, PO Box 4342 Melbourne, Victoria 3001 and authorises the facility located at Silvan Water Treatment Plant, Stonyford Road, Silvan Victoria, to be operated as a major hazard facility.

The Major Hazard Facility Licence was issued for a term of 5 years and will expire on 19 February 2009.

The licence did not include conditions.

The following Schedule 1 materials were authorised by the licence:

From Table 1 of Schedule 1

Material	UN Nos included under name
CHLORINE	1017

From Table 2 of Schedule 1

Material	Description
Nil	Nil

GREG TWEEDLY
Chief Executive

Planning and Environment Act 1987**COLAC OTWAY PLANNING SCHEME**

Notice of Approval of Amendment

Amendment C24

The Minister for Planning has approved Amendment C24 to the Colac Otway Planning Scheme.

The Amendment comes into operation on the date this notice is published in the Government Gazette.

The Amendment rezones two parcels of land south of Colac, as follows:

- Land between Hart Street and Armstrong Street, north of Irrewillipe Road, is rezoned from Rural Zone to Low Density Residential Zone.
- Land at Hart Street, north of Irrewillipe Road, is rezoned from Rural Zone to Residential 1 Zone.

The Amendment also includes "Colac Housing and Accommodation Strategy 2002" as a reference document in Cl 21.04 of the LPPF and reformats the Clause.

A copy of the Amendment can be inspected, free of charge, during office hours, at the Department of Sustainability and Environment, Planning Information Centre, Upper Plaza, Nauru House, 80 Collins Street, Melbourne and at the offices of the Colac Otway Shire Council, Rae Street, Colac.

PETER WATKINSON
Acting Deputy Secretary
Built Environment
Department of Sustainability
and Environment

Planning and Environment Act 1987**GREATER BENDIGO PLANNING SCHEME**

Notice of Approval of Amendment

Amendment C53

The Minister for Planning has approved Amendment C53 to the Greater Bendigo Planning Scheme.

The Amendment comes into operation on the date this notice is published in the Government Gazette.

The Amendment

- rezones the former Mandurang South Primary School, Mandurang South Road, Mandurang South, from Public Use Zone 2 (Education) to Low Density Residential Zone;
- applies a Development Plan Overlay and Heritage Overlay to the site.

A copy of the Amendment can be inspected, free of charge, during office hours, at the Department of Sustainability and Environment, Planning Information Centre, Upper Plaza, Nauru House, 80 Collins Street, Melbourne, the Department of Sustainability and Environment, North West Regional Office, corner of Midland Highway and Taylor Street, Epsom, and at the offices of the City of Greater Bendigo Council, Hopetoun Mill, 15 Hopetoun Street, Bendigo.

PETER WATKINSON
Acting Deputy Secretary
Built Environment
Department of Sustainability
and Environment

Planning and Environment Act 1987**HUME PLANNING SCHEME**

Notice of Approval of Amendment

Amendment C19 Part 2

The Minister for Planning has approved Amendment C19 Part 2 to the Hume Planning Scheme.

The Amendment comes into operation on the date this notice is published in the Government Gazette.

The Amendment:

- deletes part of the Heritage Overlay (HO38) on Map 6HO from land in The Avenue, Sunbury.

A copy of the Amendment can be inspected, free of charge, during office hours, at the Department of Sustainability and Environment,

Planning Information Centre, Upper Plaza, Nauru House, 80 Collins Street, Melbourne and at the offices of Hume City Council, Broadmeadows Office, 1079 Pascoe Vale Road, Broadmeadows 3047, and the Sunbury Office, 36 Macedon Street, Sunbury 3429.

PETER WATKINSON
Acting Deputy Secretary
Built Environment
Department of Sustainability
and Environment

Planning and Environment Act 1987

HUME PLANNING SCHEME

Notice of Approval of Amendment

Amendment C21

The Minister for Planning has approved Amendment C21 to the Hume Planning Scheme.

The Amendment comes into operation on the date this notice is published in the Government Gazette.

The Amendment:

- rezones land east of Pascoe Vale and south of Somerton Roads (Lots 2, 4, 5 and S3 of Plan of Subdivision 422330A) from a Public Use Zone 1 to a Business 4 Zone; introduces a new Roxburgh Park Activity Centre — South of Somerton Road Local Policy (Clause 22.12); and amends Clauses 21.03–1, 21.03–2 and 21.03–7 of the MSS.

A copy of the Amendment can be inspected, free of charge, during office hours, at the Department of Sustainability and Environment, Planning Information Centre, Upper Plaza, Nauru House, 80 Collins Street, Melbourne; and the Hume City Council Offices: the Broadmeadows Office, 1079 Pascoe Vale Road, Broadmeadows 3047; the Sunbury Office, 36 Macedon Street, Sunbury 3429 and the Craigieburn Office, Craigieburn Road West, Craigieburn 3064.

PETER WATKINSON
Acting Deputy Secretary
Built Environment
Department of Sustainability
and Environment

Planning and Environment Act 1987

MANSFIELD PLANNING SCHEME

Notice of Approval of Amendment

Amendment C2

The Minister for Planning has approved Amendment C2 to the Mansfield Planning Scheme.

The Amendment comes into operation on the date this notice is published in the Government Gazette.

1. The Amendment rezones part Lot 2, PS119126, part Lot 2, PS110658, and part CA's 2, 17, 18, Section 2, Township of Mansfield, Ailsa Street, Mansfield from Residential 1 to Public Park and Recreation Zone (Map 12);
2. rezones Lots 4 and 5, PS126296, Parish of Beolite, Mt Battery Road, Mansfield from Rural to Rural Living (Maps 12 & 13);
3. rezones CAs 2C and 2F Section A, Parish of Boorolite, Shanks Road, Boorolite from Public Use Zone 1 to Rural (Map 13);
4. rezones part CA 13, Section A, Parish of Boorolite, Shanks Road, Boorolite from Rural to Public Use Zone 1 (Service and utility) (Map 13);
5. rezones Part CA 21, Section A, Parish of Changue, on the southern side of Mount Buller Road, Sawmill Settlement, from Public Park and Recreation to Rural (Maps 16 & 17);
6. rezones part CA 39, Parish of Howqua, Peacheys Road, Howqua from Public Park and Recreation to Environmental Rural (Map 20);
7. rezones part CAs 35, 35A, 36, 37, 169, 169A, Parish of Howqua West, Lot 3, PS 426965, and Lots 74, 75, 76, 77, 78 and 79, PS426966, Mountain Bay from Public Park and Recreation Zone to Special Use 3 (Mountain Bay) (Maps 20 & 21);
8. rezones CA 88C, Parish of Boorolite, Three Chain Road, Boorolite from Public Conservation and Resource to Rural (Map 23);
9. rezones CA 1 and part CAs 1 and 2, Section E, Parish of Jamieson, Mansfield — Woods Point Road, Jamieson from Public Park and Recreation to Environmental Rural (Map 24);

10. rezones CA 3, Section C, Parish of Jamieson, Mansfield — Wood Points Road, Jamieson from part Public Use 1 and part Public Park and Recreation to Rural Living (Map 26);
11. rezones Lots 1, 2 and 3, PS 121787, Lots 1, 2 and 3, PS 214662, CAs 11, 15 and 16, Section 19, CAs 1, 3, 4 and 7 and part CAs 2, 5, 6 and 8, Section 18, and part CAs 1, 2, 3, 4, 5, 6, 7, 8, 9 and 10, Section 25, Township of Jamieson, Bridge Street and Bank Street, Jamieson from Public Park and Recreation to Environmental Rural (Map 26);
12. rezones CA 1, Section 18, CAs 1B and 3, Section B, part CA 2, Section B and part CA 2A, Section 6, Parish of Kevington, and Lots 1 and 2, PS 89500, Mansfield — Woods Point Road, Kevington from Public Conservation and Resource to Environmental Rural (Map 29);
13. rezones CA 3, Section 3, Parish of Kevington, Mansfield — Woods Point Road, Kevington from part Road 1 and part Public Conservation and Resource to Environmental Rural (Map 29);
14. rezones CA 5, Section 22, Parish of Kevington, Mansfield — Woods Point Road, Kevington from Road 1 to Environmental Rural (Map 29);
15. applies the Significant Landscape Overlay 2 (Alpine approach significant landscape area) to areas east of Mansfield and west of Merrijig that are now indicated on planning scheme maps as having the 'Significant Landscape Overlay' applying to it (Maps 12SLO & 13SLO);
16. applies the Heritage Overlay (Heritage place No HO38) to the Woodfield railway trestle bridge over Merton Creek, Woodfield (Map 6HO);
17. applies the Heritage Overlay (Heritage place No HO71) to the Howqua Track (Howqua Hills Road), running between Mt Buller Road and Sheeppark Flat (Howqua River) (Maps 13HO, 14HO, 15HO, 17HO, 18HO & 23HO);
18. applies the Heritage Overlay (Heritage place No HO47) to the Tunnel Bend Township Conservation Area (Map 17HO);
19. applies the Development Plan Overlay 1 to

land zoned Residential 1 on the southern side of Mount Buller Road, between Alpine Ridge and Changue Roads, Sawmill Settlement that is now indicated on planning scheme maps as having the 'Development Plan Overlay' applying to it (Map 16 DPO).

A copy of the Amendment can be inspected, free of charge, during office hours, at the Department of Sustainability and Environment, Planning Information Centre, Upper Plaza, Nauru House, 80 Collins Street, Melbourne, North East Regional Office, 35 Sydney Road, Benalla and at the offices of the Mansfield Shire Council, 33 Highett Street, Mansfield 3722.

PETER WATKINSON
Acting Deputy Secretary
Built Environment
Department of Sustainability
and Environment

Planning and Environment Act 1987

MANSFIELD PLANNING SCHEME

Notice of Approval of Amendment

Amendment C3

The Minister for Planning has approved Amendment C3 to the Mansfield Planning Scheme.

The Amendment comes into operation on the date this notice is published in the Government Gazette.

The Amendment alters the planning scheme map and the schedule to the Heritage Overlay so that the Leichardt Gold crushing Battery Wye's Creek Pemburthy heritage places is shown in the Mansfield Planning Scheme and is with the Victorian Heritage Register.

A copy of the Amendment can be inspected, free of charge, during office hours at the Department of Sustainability and Environment, Planning Information Centre, Upper Plaza, Nauru House, 80 Collins Street, Melbourne and at the Mansfield Shire Council Municipal Offices, Highett Street, Mansfield.

PETER WATKINSON
Acting Deputy Secretary
Built Environment
Department of Sustainability
and Environment

Planning and Environment Act 1987**MARIBYRNONG PLANNING SCHEME**Notice of Approval of Amendment
Amendment C40

The Minister for Planning has approved Amendment C40 to the Maribyrnong Planning Scheme.

The Amendment comes into operation on the date this notice is published in the Government Gazette.

The Amendment:

- rezones land at the south-west corner of Mitchell Street and Rosamond Road, Maidstone from an Industrial 3 Zone to a Residential 1 Zone, includes most of the land in a Development Plan Overlay (DPO6), applies an Environmental Audit Overlay (EAO) to the land and a Public Acquisition Overlay (PAO2) to the north east corner of the land.

A copy of the Amendment can be inspected, free of charge, during office hours, at the Department of Sustainability and Environment, Planning Information Centre, Upper Plaza, Nauru House, 80 Collins Street, Melbourne and at the offices of Maribyrnong City Council, corner of Napier and Hyde Streets, Footscray.

PETER WATKINSON
Acting Deputy Secretary
Built Environment
Department of Sustainability
and Environment

Planning and Environment Act 1987**MILDURA PLANNING SCHEME**Notice of Approval of Amendment
Amendment C21

The Minister for Planning has approved Amendment C21 to the Mildura Planning Scheme.

The Amendment comes into operation on the date this notice is published in the Government Gazette.

The Amendment proposes to:

- rezone the Red Cliffs Caravan Park located at Lot 1, PS 428251N, Calder Highway, Red

Cliffs from Public Park and Recreation Zone to Special Use Zone; and

- introduces a new Schedule 6 to the Special Use Zone.

A copy of the Amendment can be inspected, free of charge, during office hours, at the Department of Sustainability and Environment, Planning Information Centre, Upper Plaza, Nauru House, 80 Collins Street, Melbourne and at the Department's North West Regional Office, 1 Taylor Street, Epsom and at the offices of the Mildura Rural City Council, 108–116 Madden Avenue, Mildura.

PETER WATKINSON
Acting Deputy Secretary
Built Environment
Department of Sustainability
and Environment

Planning and Environment Act 1987**MITCHELL PLANNING SCHEME**Notice of Approval of Amendment
Amendment C28

The Minister for Planning has approved Amendment C28 to the Mitchell Planning Scheme.

The Amendment comes into operation on the date this notice is published in the Government Gazette.

The Amendment introduces a Public Acquisition Overlay to land known as Lots 8 and 9 LP 6746, Parish of Merriang, County of Bourke (Cameron's Lane, Beveridge) to enable Goulburn Valley Region Water Authority to acquire the land for reuse by irrigation of reclaimed wastewater from the Wallan Wastewater Management Facility.

The Minister has granted the following permits under Division 5 Part 4 of the Act:

Permit No.: P303047.

Description of land: Lots 8 and 9, Parish of Merriang, Camerons Lane, Beveridge (re-use site), an unused government road an unused government road reserve (pipeline route) and Crown Portion 53, Parish of Wallan, Wallan (pump station site).

A copy of the Amendment and permit/s can be inspected, free of charge, during office hours, at the Department of Sustainability and Environment, Planning Information Centre, Upper Plaza, Nauru House, 80 Collins Street, Melbourne and at the offices of the Mitchell Shire Council, 113 High Street, Broadford.

PETER WATKINSON
Acting Deputy Secretary
Built Environment
Department of Sustainability
and Environment

Planning and Environment Act 1987

WARRNAMBOOL PLANNING SCHEME

Notice of Approval of Amendment

Amendment C18

The Minister for Planning has approved Amendment C18 to the Warrnambool Planning Scheme.

The Amendment comes into operation on the date this notice is published in the Government Gazette.

The Amendment introduces heritage protection to 16 sites within Allansford, Bushfield, Woodford and Farnham; and amends Clause 21.08 "Settlement and Housing Development" and Clause 22.01–2 "Sites of Heritage Interest".

A copy of the Amendment can be inspected, free of charge, during office hours, at the Department of Sustainability and Environment, Planning Information Centre, Upper Plaza, Nauru House, 80 Collins Street, Melbourne and at the offices of the Warrnambool City Council, Liebig Street, Warrnambool.

PETER WATKINSON
Acting Deputy Secretary
Built Environment
Department of Sustainability
and Environment

ORDERS IN COUNCIL

VESTED LANDS TO REVERT TO THE CROWN

The Governor in Council under section 17(2) of the **Victorian Plantations Corporation Act 1993** divests the lands described in the schedule hereunder and reverts the subject lands in the Crown:

SCHEDULE

Crown Allotment 2004 Parish of Too-rour (0.417 ha) as shown on Plan LEGL./03-010 lodged in the Central Plan Office.

Crown Allotment 2003 Parish of Too-rour (0.247 ha) as shown on Plan LEGL./03-010 lodged in the Central Plan Office.

Crown Allotment 2002 Parish of Lima (3.38 ha) as shown on Plan LEGL./02-116 lodged in the Central Plan Office.

Crown Allotment 2004 Parish of Lima (1.52 ha) as shown on Plan LEGL./02-116 lodged in the Central Plan Office.

Crown Allotment 2001 Parish of Lima (161.1 ha) as shown on Plan LEGL./02-116 lodged in the Central Plan Office.

Crown Allotment 2005 Parish of Too-rour (1.1 ha) as shown on Plan LEGL./03-009 lodged in the Central Plan Office.

Crown Allotment 2002 Parish of Boho (4.16 ha) as shown on Plan LEGL./03-009 lodged in the Central Plan Office.

Crown Allotment 2001 Parish of Boho (14.23 ha) as shown on Plan LEGL./03-009 lodged in the Central Plan Office.

Crown Allotment 2001 Parish of Dueran (42.25 ha) as shown on Plan LEGL./03-020 lodged in the Central Plan Office.

Crown Allotment 2007 Parish of Dueran (0.286 ha) as shown on Plan LEGL./03-020 lodged in the Central Plan Office.

Crown Allotment 2008 Parish of Dueran (1.23 ha) as shown on Plan LEGL./03-020 lodged in the Central Plan Office.

Crown Allotment 2003 Parish of Dueran (3.82 ha) as shown on Plan LEGL./03-020 lodged in the Central Plan Office.

Crown Allotment 2003 Parish of Whitfield South (0.38 ha) as shown on Plan LEGL./03-011 lodged in the Central Plan Office.

Crown Allotment 2001 Parish of

Toombullup (33.3 ha) as shown on Plan LEGL./03-011 lodged in the Central Plan Office.

Crown Allotment 2002 Parish of Whitfield South (0.865 ha) as shown on Plan LEGL./03-011 lodged in the Central Plan Office.

Crown Allotment 2001 Parish of Matong North (0.95 ha) as shown on Plan LEGL./03-013 lodged in the Central Plan Office.

Crown Allotment 2016 Parish of Berrigama (4.25 ha) as shown on Plan LEGL./03-012 lodged in the Central Plan Office.

Crown Allotment 2009 Parish of Granya (2.73 ha) as shown on Plan LEGL./03-012 lodged in the Central Plan Office.

Crown Allotment 2010 Parish of Granya (1.67 ha) as shown on Plan LEGL./03-012 lodged in the Central Plan Office.

Crown Allotment 2017 Parish of Berrigama (8.05 ha) as shown on Plan LEGL./03-012 lodged in the Central Plan Office.

Crown Allotment 2006 Parish of Berrigama (0.4045 ha) as shown on Plan LEGL./03-012 lodged in the Central Plan Office.

Crown Allotment 2001 Parish of Bungil East (2.6 ha) as shown on Plan LEGL./02-065 lodged in the Central Plan Office.

Crown Allotment 2007 Parish of Koetong (1.4 ha) as shown on Plan LEGL./02-065 lodged in the Central Plan Office.

Crown Allotment 2011 No Section Parish of Howqua West being 0.259 as shown on Plan LEGL./03-017 lodged in the Central Plan Office.

Crown Allotment 2019 No Section Parish of Howqua West being 0.066 as shown on Plan LEGL./03-017 lodged in the Central Plan Office.

This Order is effective from the date on which it is published in the Government Gazette
Dated 6 April 2004

Responsible Minister
JOHN THWAITES
Minister for Environment

DIANE CASEY
Clerk of the Executive Council

Crown Land (Reserves) Act 1978
Interpretation of Legislation Act 1984
 AMENDMENT OF TEMPORARY
 RESERVATIONS

The Governor in Council, under Section 4(1) of the **Crown Land (Reserves) Act 1978** and Section 27 of the **Interpretation of Legislation Act 1984** amends:—

BUNGEET — the Order in Council made on 4 September 1893 and published in the Government Gazette on 8 September 1893 — page 3778 of the temporary reservation of an area of 2.031 hectares in the Parish of Bungeet, County of Moira as a site for Supply of Gravel by the deletion of the words “Site for Supply of Gravel” and the substitution therefor of the words “Conservation of an area of natural interest”. 0804748 — (GP1262).

CHILTERN WEST — the Order in Council made on 30 January 1893 and published in the Government Gazette on 3 February 1893 — page 681 of the temporary reservation of an area of land 4.044 hectares in the Parish of Chiltern West, County of Bogong as a Site for supply of Gravel by the deletion of the words “Site for supply of Gravel” and the substitution therefor of the words “Conservation of an area of natural interest”. 1105989 — (GP1343).

MOLKA — the Order in Council made on 6 August 1883 and published in the Government Gazette on 10 August 1883 — page 1821 of the temporary reservation of an area of 31.00 hectares of land in the Parish of Molka, County of Moira as a site for affording access to water by the deletion of the words “Site for affording access to Water” and the substitution therefor of the words “Conservation of an area of natural interest”. 2003187 — (GP1279)

NEILBOROUGH — the Order in Council made on 11 March 1878 and published in the Government Gazette on 15 March 1878 — page 582 of the temporary reservation of an area of land 4.0469 hectares in the Parish of Neilborough, County of Bendigo as a site for quarry by the deletion of the words “Site for Quarry” and the substitution therefor of the words “Conservation of an area of natural interest”. — 0617305.

WARANGA — the Order in Council made on 28 January 1890 and published in the

Government Gazette on 31 January 1890 — page 359 of the temporary reservation of an area of 13.759 hectares, more or less, of land in the Parish of Waranga, County of Rodney as a site for water supply purposes by the deletion of the words “Site for Water Supply purposes” and the substitution therefor of the words “Conservation of an area of natural interest”. — 0606831.

This Order is effective from the date on which it is published in the Government Gazette.

Dated 6 April 2004

Responsible Minister
 MARY DELAHUNTY
 Minister for Planning

DIANE CASEY
 Clerk of the Executive Council

Crown Land (Reserves) Act 1978
 TEMPORARY RESERVATION OF
 CROWN LANDS

The Governor in Council under section 4(1) of the **Crown Land (Reserves) Act 1978** temporarily reserves the following Crown lands which in his opinion are required for the purposes mentioned:—

MUNICIPAL DISTRICT OF THE
 LODDON SHIRE COUNCIL

BARWO — Conservation of an area of natural interest, 6.331 hectares being Crown Allotment 1G, Section D, Parish of Barwo as indicated by hatching on plan hereunder. (GP 1348) — (2012553).

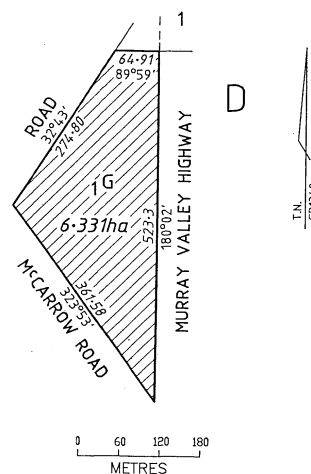

MUNICIPAL DISTRICT OF THE
CAMPASPE SHIRE COUNCIL

BURRAMBOOT EAST - Public Purposes, 7.7 hectares, more or less, being Crown Allotment 2003, Parish of Burramboot East as indicated by hatching on plan hereunder. (GP1396) — (06L6-10855).

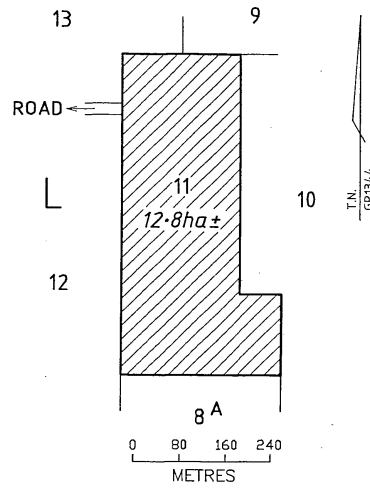
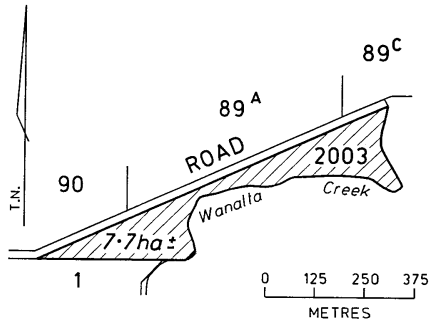

MUNICIPAL DISTRICT OF THE
INDIGO SHIRE COUNCIL

LILLIPUT — Conservation of an area of natural interest, 4.5 hectares, more or less, being Crown Allotment 25, Section L, Parish of Lilliput as indicated by hatching on plan hereunder. (GP 1345) — (1108875).

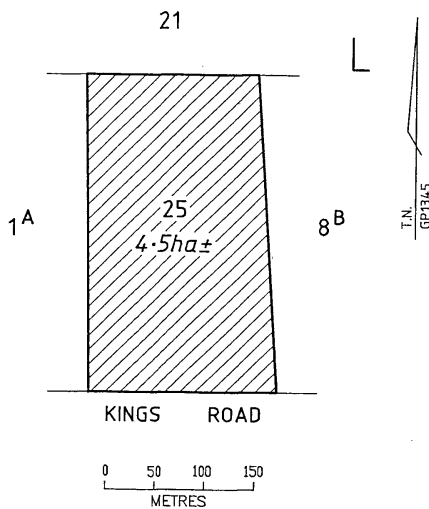

MUNICIPAL DISTRICT OF THE
RURAL CITY OF BENALLA

LURG — Conservation of an area of natural interest, 2.023 hectares, being Crown Allotment 15C, No Section, Parish of Lurg as indicated by hatching on plan hereunder. (GP 1341) — (L7/5689).

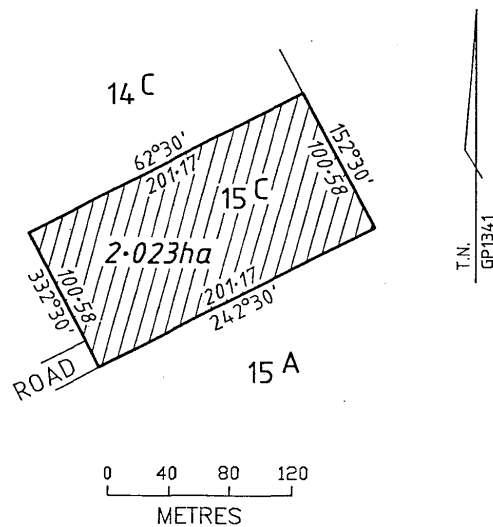

MUNICIPAL DISTRICT OF THE
INDIGO SHIRE COUNCIL

LILLIPUT — Conservation of an area of natural interest, 12.8 hectares, more or less, being Crown Allotment 11, Section L, Parish of Lilliput as indicated by hatching on plan hereunder. (GP 1344) — (P202013).

MUNICIPAL DISTRICT OF THE
RURAL CITY OF BENALLA

LURG — Conservation of an area of natural interest, 2.023 hectares, being Crown Allotment 24C, No Section, Parish of Lurg as indicated by hatching on plan hereunder. (GP 1340) — (L7/5688).

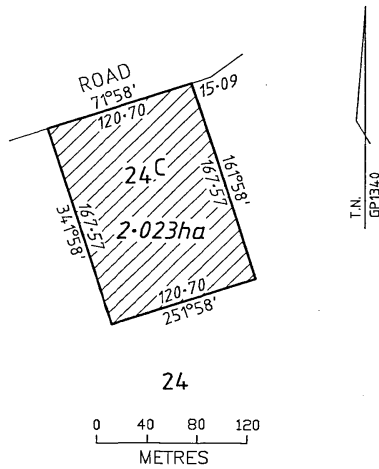

MUNICIPAL DISTRICT OF THE
MT ALEXANDER SHIRE COUNCIL

MALDON — Conservation of an area of natural interest, 15 hectares, more or less, being Crown Allotment 17A, Section M, Parish of Maldon as indicated by hatching on plan hereunder. (GP1371) — (06L6-10748).

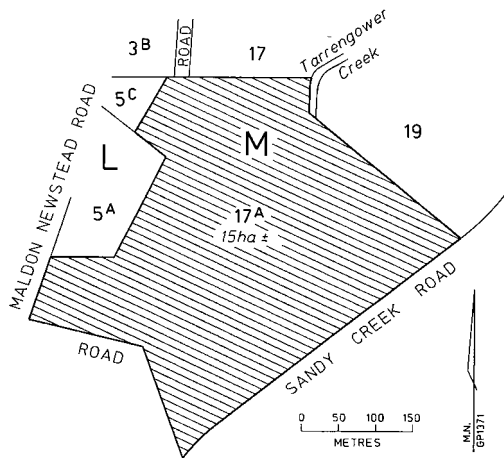

MUNICIPAL DISTRICT OF THE
MT ALEXANDER SHIRE COUNCIL

METCALFE — Conservation of an area of natural interest, total area 7.1 hectares, more or less, being Crown Allotments 30D and 30E, Section 5, Parish of Metcalfe as indicated by hatching on plan hereunder. (GP1361) — (06L6-10757).

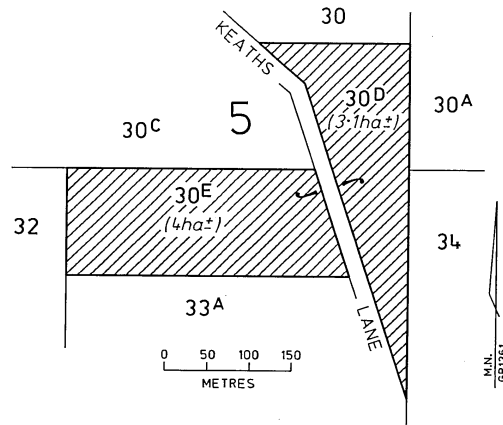

Total Area of Hatched Portions 7.1ha±

MUNICIPAL DISTRICT OF THE
STRATHBOGIE SHIRE COUNCIL

MONEA SOUTH — Conservation of an area of natural interest, 5.2 hectares, being Crown Allotment 36C, No Section, Parish of Monea South as indicated by hatching on plan hereunder. (GP 1263) — (L7/1351).



MUNICIPAL DISTRICT OF THE
STRATHBOGIE SHIRE COUNCIL

OLD LONGWOOD — Conservation of an area of natural interest, 2.487 hectares, being Crown Allotment 4 Section J, Township of Old Longwood as indicated by hatching on plan hereunder. (GP 1274) — (L7/5780).

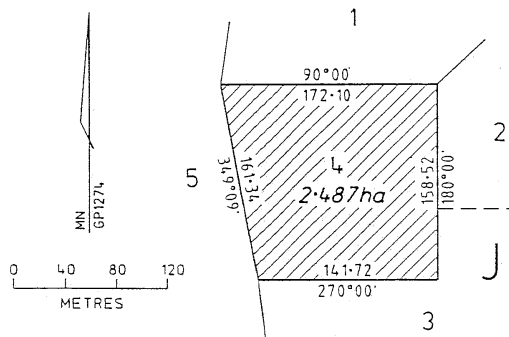

MUNICIPAL DISTRICT OF THE CENTRAL GOLDFIELDS SHIRE COUNCIL
 TALBOT — Conservation of an area of natural interest, 7.7 hectares, more or less, being Crown Allotment 6, Section 7A, Township of Talbot, Parish of Amherst as indicated by hatching on plan hereunder. (GP1432) — (06L6-10908).

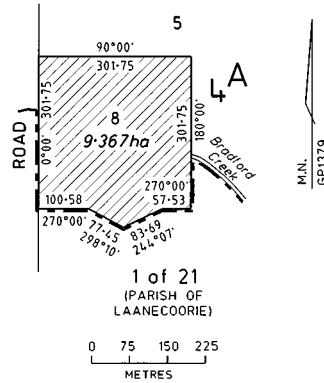

This Order is effective from the date on which it is published in the Government Gazette.

Dated 6 April 2004

Responsible Minister
 MARY DELAHUNTY
 Minister for Planning

DIANE CASEY
 Clerk of the Executive Council

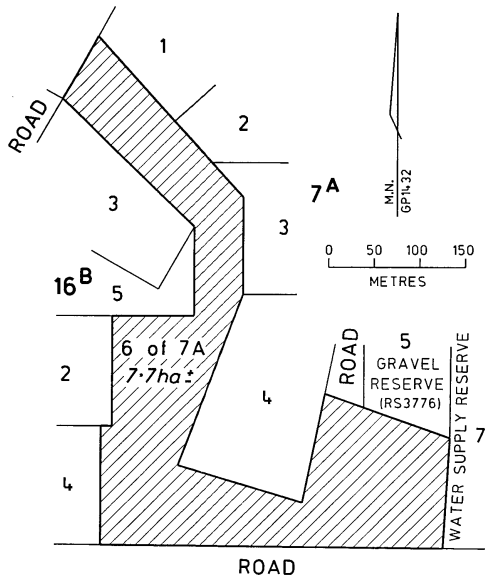

MUNICIPAL DISTRICT OF THE LODDON SHIRE COUNCIL
 WOODSTOCK — Conservation of an area of natural interest, 9.367 hectares, being Crown Allotment 8, Section 4A, Parish of Woodstock as indicated by hatching on plan hereunder. (GP1379) — (0609609).

Crown Land (Reserves) Act 1978
 TEMPORARY RESERVATION OF
 CROWN LANDS

The Governor in Council under section 4(1) of the **Crown Land (Reserves) Act 1978** temporarily reserves the following Crown lands which in his opinion are required for the purposes mentioned:—

MUNICIPAL DISTRICT OF THE CITY OF MOORABOOL SHIRE COUNCIL
 BLACKWOOD — Conservation of an area of historic interest, 398 square metres being Crown Allotment 2001, Parish of Blackwood as indicated by hatching on plan hereunder. (GP1164A) — (0702122).

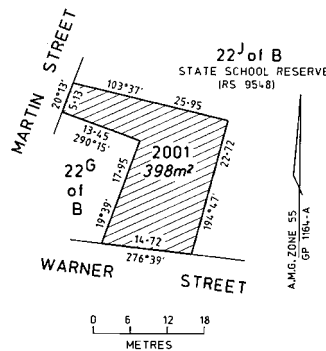

MUNICIPAL DISTRICT OF THE MOUNT ALEXANDER SHIRE COUNCIL
 CASTLEMAINE — Tourist Camping purposes, 2.765 hectares, being Crown Allotment 2006, Township of Castlemaine, Parish of Castlemaine as indicated by hatching on plan hereunder. (GP1301-A) — (0613631).

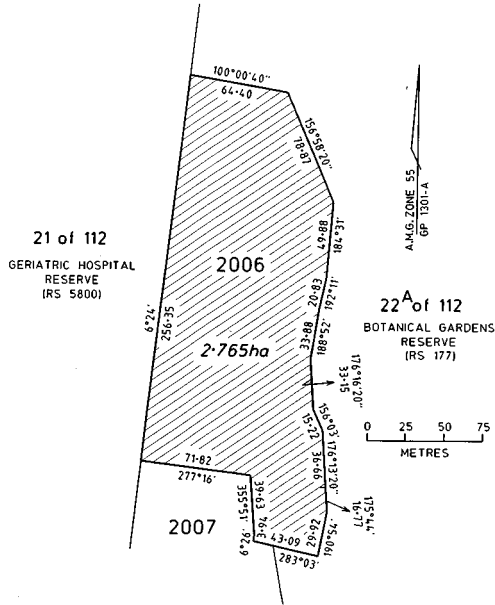

MUNICIPAL DISTRICT OF THE HINDMARSH SHIRE COUNCIL
 GERANG GERUNG — Conservation of an area of natural interest, combined area 81.28 hectares, being Crown Allotments 51 and 2001, Parish of Gerang Gerung as indicated by hatching on plan hereunder. (GP1309) — (0204635).

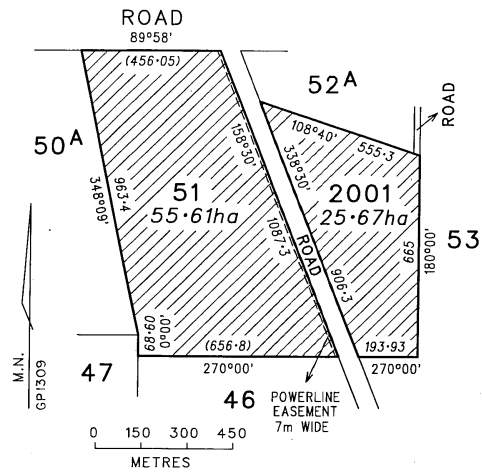

MUNICIPAL DISTRICT OF THE MOUNT ALEXANDER SHIRE COUNCIL
 CASTLEMAINE — Public Recreation, 1.798 hectares, being Crown Allotment 2007, Township of Castlemaine, Parish of Castlemaine as indicated by hatching on plan hereunder. (GP1301-B) — (2013302).

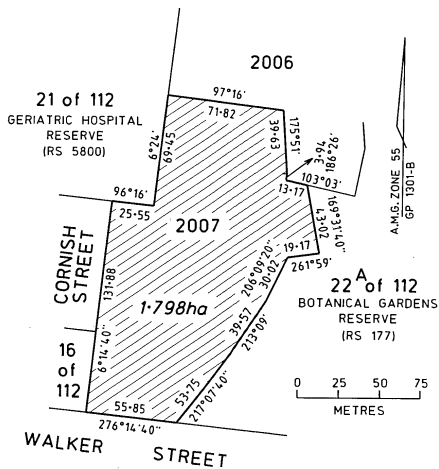

MUNICIPAL DISTRICT OF THE ARARAT RURAL CITY COUNCIL
 LEXINGTON — Conservation of an area of natural interest, 43 hectares, more or less, being Crown Allotment 9C, Section 15, Parish of Lexington as indicated by hatching on plan hereunder. (GP70) — (Rs 12929).

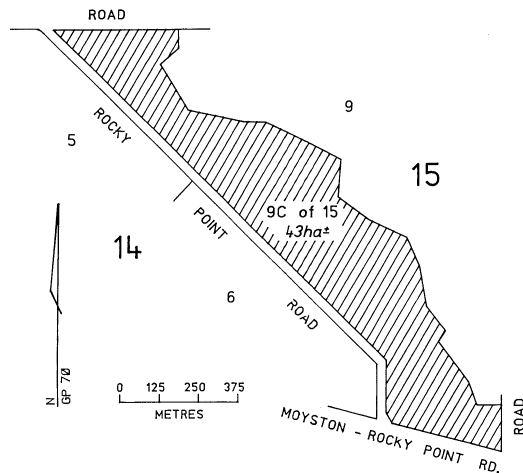

MUNICIPAL DISTRICT OF THE
HINDMARSH SHIRE COUNCIL

NI NI — Conservation of an area of natural interest, 15.76 hectares, being Crown Allotment 116A, Parish of Ni Ni as indicated by hatching on plan hereunder. (GP1320) — (026574).

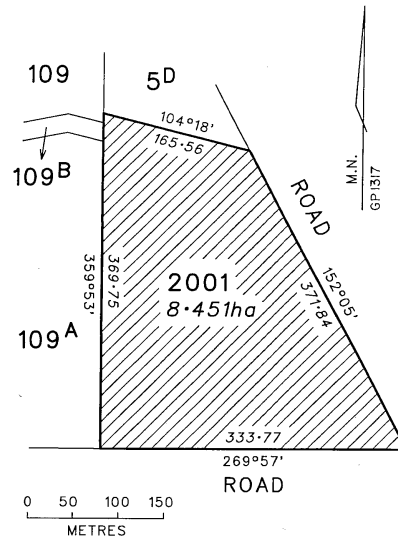
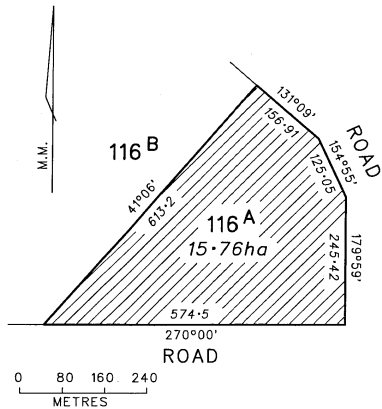

MUNICIPAL DISTRICT OF THE
GLENELG SHIRE COUNCIL

PORTLAND — Public purposes, 2280 square metres, more or less, being Crown Allotment 30E, Section C, Township of Portland, Parish of Portland as indicated by hatching on plan hereunder. (GP1414) — (Rs 5019).

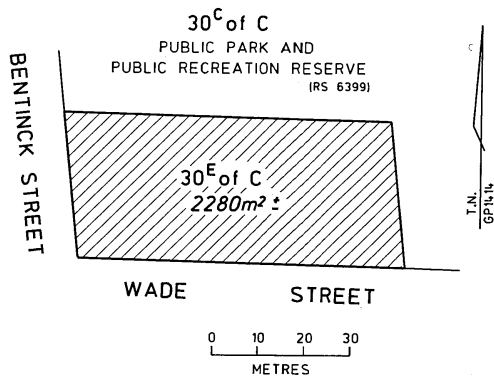

MUNICIPAL DISTRICT OF THE
WEST WIMMERA SHIRE COUNCIL

YOUPAYANG — Conservation of an area of natural interest, 20.01 hectares, being Crown Allotment 15B, Parish of Youpayang as indicated by hatching on plan hereunder. (GP1333) — (0306775).

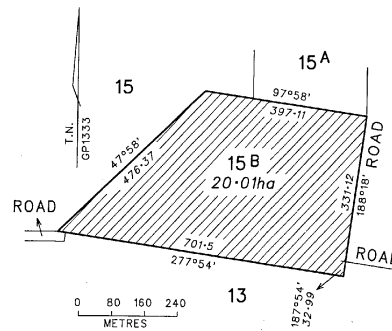

MUNICIPAL DISTRICT OF THE
YARRIAMBIAK SHIRE COUNCIL

YELLANGIP — Conservation of an area of natural interest, 8.451 hectares, being Crown Allotment 2001, Parish of Yellangip as indicated by hatching on plan hereunder. (GP1317) — (024477).

This Order is effective from the date on which it is published in the Government Gazette.

Dated 6 April 2004

Responsible Minister
MARY DELAHUNTY
Minister for Planning

DIANE CASEY
Clerk of the Executive Council

Crown Land (Reserves) Act 1978REVOCATION OF
TEMPORARY RESERVATIONS

The Governor in Council under section 10 of the **Crown Land (Reserves) Act 1978** revokes the following temporary reservations:

GERANG GERUNG — The temporary reservation by Order in Council of 15 October 1883 of an area of 116 hectares, more or less, of land in the Parish of Gerang Gerung, in two separate portions, as a site for Water Supply purposes, revoked as to part by Orders in Council of 17 March 1891 and 10 February 1915 so far as the balance remaining containing 77.237 hectares, more or less. — (Rs 05804).

GERANG GERUNG — The temporary reservation by Order in Council of 16 March 1886 of an area of 4.047 hectares, of land in the Parish of Gerang Gerung as a site for Water Supply purposes. — (Rs 05804).

HARROW — The temporary reservation by Order in Council of 18 May 1874 of an area of 1.619 hectares of land in the Township of Harrow as a site for State School purposes, revoked as to part by Order in Council of 16 October 1939 so far as the balance remaining containing 1.514 hectares, more or less. — (Rs 14230).

MOKEPILLY — The temporary reservation by Order in Council of 6 September 1880 of an area of 6.728 hectares of land in Section Y, Parish of Mokepilly as a site for affording access to Water. — (P023143).

NI NI — The temporary reservation by Order in Council of 4 November 1889 of an area of 17.619 hectares of land in the Parish of Ni Ni as a site for Water Supply purposes, revoked as to part by Order in Council of 22 October 1963 so far as the balance remaining containing 15.798 hectares, more or less. — (Rs 35043).

PORTLAND — The temporary reservation by Order in Council of 2 August 1949 of an area of 2276 square metres, more or less, of land in the Township of Portland, Parish of Portland as a site for Water Supply purposes [amended to Public Park and Recreation purposes by Order in Council of 3 October 1995]. — (Rs 5019).

ST. ARNAUD — The temporary reservation by Order in Council of 20 February 1914 of an area of 18.36 hectares of land in Section B, Parish of

St. Arnaud as a site for Supply of Gravel. — (06L6-1829).

YELLANGIP — The temporary reservation by Order in Council of 18 February 1908 of an area of 6.584 hectares of land in the Parish of Yellangip as a site for Public Recreation and Camping purposes. — (Rs 0222).

YOUPAYANG — The temporary reservation by Order in Council of 28 February 1888 of an area of 20.012 hectares of land being Crown Allotment 15B, Parish of Youpayang as a site for Camping and Watering purposes. — (Rs 43083).

This Order is effective from the date on which it is published in the Government Gazette.

Dated 6 April 2004

Responsible Minister
MARY DELAHUNTY
Minister for Planning

DIANE CASEY
Clerk of the Executive Council

Crown Land (Reserves) Act 1978NOTICE OF INTENTION TO REVOKE
TEMPORARY RESERVATIONS

The Governor in Council under section 10 of the **Crown Land (Reserves) Act 1978** gives notice of intention to revoke the following temporary reservations:

COWANGIE — The temporary reservation by Order in Council of 28 April 1927 of an area of 1.872 hectares of land in Section 14, Township of Cowangie, Parish of Tutye (formerly Crown Allotments 11–16 inclusive) as a site for a Rubbish Depot. — (Rs 3450).

COWANGIE — The temporary reservation by Order in Council of 18 September 1956 of an area of 1.437 hectares of land in Section 10, Township of Cowangie, Parish of Tutye as a site for a Rubbish Depot. — (Rs 3450).

DOOEN — The temporary reservation by Order in Council of 3 October 1950 of an area of 2.35 hectares, more or less, of land in the Parish of Dooen as a site for a Rubbish Depot. — (Rs 6588).

DOOEN — The temporary reservation by Order in Council of 9 March 1886 of an area of 30.35 hectares, more or less, of land in the

Parish of Dooen as a site for Water Supply purposes. — (Rs 6339).

DOOEN — The temporary reservation by Order in Council of 10 August 1874 of an area of 129.50 hectares of land in the Parish of Dooen as a site for Watering and Camping purposes, revoked as to part by various Orders, so far as the balance remaining. — (Rs 6340).

DOOEN — The temporary reservation by Order in Council of 14 December 1874 of an area of 78.23 hectares of land in the Parish of Dooen as a site for Watering and Camping purposes, in addition to and adjoining the site temporarily reserved therefor by Order in Council of 10 August 1874, revoked as to part by various Orders, so far as the balance remaining. — (Rs 6340).

GARIBALDI — The temporary reservation by Order in Council of 17 May 1887 of an area of 4.869 hectares of land in the Township of Garibaldi (formerly Parish of Enfield) as a site for supply of material for Road-making purposes, revoked as to part by Orders in Council of 12 July, 1909 and 23 January 1968 so far as the balance remaining containing 2.808 hectares, more or less. — (Rs 8892).

KUNAT KUNAT — The temporary reservation by Order in Council of 20 December 1900 of an area of 2.0234 hectares, more or less, of land in the Parish of Kunat Kunat (formerly Mallee Allotment 407) as a site for Manure and Night Soil Depot. — (Rs 3509).

MULLROO — The temporary reservation by Order in Council of 20 February 1962 of an area of 4.937 hectares, more or less, of land in the Parish of Mullroo as a site for a Rubbish Depot. — (Rs 8110).

TYALLA — The temporary reservation by Order in Council of 16 October 1956 of an area of 1.619 hectares, more or less, of land in the Parish of Tyalla as a site for a Rubbish Depot. — (Rs 7506).

UNDERBOOL — The temporary reservation by Order in Council of 11 November 1919 of an area of 4.057 hectares of land in the Parish of Underbool (formerly Township of Underbool) as a site for a Sanitary Depot, revoked as to part by Order in Council of 11 December 1945 so far as the balance remaining containing 3.255 hectares, more or less. — (Rs 5709).

UNDERBOOL — The temporary reservation by Order in Council of 11 December 1945 of an area of 8018 square metres of land in the Parish of Underbool as a site for a Rubbish Depot. — (Rs 2044).

This Order is effective from the date on which it is published in the Government Gazette.

Dated 6 April 2004

Responsible Minister
MARY DELAHUNTY
Minister for Planning

DIANE CASEY
Clerk of the Executive Council

This page left blank intentionally

**SUBORDINATE LEGISLATION ACT 1994
NOTICE OF MAKING OF STATUTORY
RULES**

Notice is hereby given under Section 17 (2) of the **Subordinate Legislation Act 1994** of the making of the following Statutory Rules:

26. *Statutory Rule:* Fisheries
(Amendment)
Regulations 2004
Authorising Act: Fisheries Act 1995
Date of making: 6 April 2004
27. *Statutory Rule:* Fisheries (Abalone)
Regulations 2004
Authorising Act: Fisheries Act 1995
Date of making: 6 April 2004

**SUBORDINATE LEGISLATION ACT 1994
NOTICE THAT STATUTORY RULES ARE
OBTAINABLE**

Notice is hereby given under Section 17 (3) of the **Subordinate Legislation Act 1994** that the following Statutory Rules were first obtainable from Information Victoria, 356 Collins Street, Melbourne on the date specified:

24. *Statutory Rule:* Electricity Safety
(Equipment
Efficiency)
(Amendment)
Regulations 2004
Authorising Act: Electricity Safety
Act 1998
Date first obtainable: 6 April 2004
Code A
25. *Statutory Rule:* Tobacco (Victorian
Health Promotion
Foundation)
(Membership)
Regulations 2004
Authorising Act: Tobacco Act 1987
Date first obtainable: 6 April 2004
Code A

**PRICING FOR SPECIAL GAZETTE,
PERIODICAL GAZETTE AND
VICTORIAN LEGISLATION**

Retail price varies according to the number of pages in each Victoria Government Special Gazette, Victoria Government Periodical Gazette and Victorian legislation. The table below sets out the prices that apply.

<i>Price Code</i>	<i>No. of Pages (Including cover and blank pages)</i>	<i>Price*</i>
A	1–16	\$3.70
B	17–32	\$5.50
C	33–48	\$7.55
D	49–96	\$11.75
E	97–144	\$15.20
F	145–192	\$17.95
G	193–240	\$20.70
H	241–288	\$22.05
I	289–352	\$24.80
J	353–416	\$29.00
K	417–480	\$33.10
L	481–544	\$38.60
M	545–608	\$44.10
N	609–672	\$49.65
O	673–736	\$55.10
P	737–800	\$60.65

**All Prices Include GST*

craftsmanpress

The *Victoria Government Gazette* is published by The Craftsman Press Pty Ltd with the authority of the Government Printer for the State of Victoria

© State of Victoria 2004

This publication is copyright. No part may be reproduced by any process except in accordance with the provisions of the Copyright Act.

Address all enquiries to the Government Printer for the State of Victoria
Level 2 1 Macarthur Street
Melbourne 3002
Victoria Australia

How To Order

	Mail Order	Craftsman Press Pty Ltd 125 Highbury Road Burwood 3125 DX – 32510 Burwood
	Telephone	(03) 9926 1233
	Fax	(03) 9926 1292
	email	gazette@craftpress.com.au
	Retail & Mail Sales	Information Victoria 356 Collins Street Melbourne 3000
	Telephone	1300 366 356
	Fax	(03) 9603 9920
	Retail Sales	City Graphics Level 1 520 Bourke Street Melbourne 3000
	Telephone	(03) 9600 0977
	Fax	(03) 9600 0989

Recommended Retail Price \$1.95 (includes GST)

ISSN 0819-5471



9 770819 550225