



Victoria Government Gazette

By Authority of Victorian Government Printer

No. G 21 Thursday 20 May 2004

www.gazette.vic.gov.au

GENERAL

TABLE OF PROVISIONS

Private Advertisements	1258	Proclamations	1275
Dissolution of Partnership		Government and Outer Budget Sector	
Alberto's Hair Stylist	1258	Agencies Notices	1277
C&T Bricklaying	1258	Orders in Council	1319
IRonline	1258	Acts:	
Estates of Deceased Persons		Crown Land (Reserves);	
Aitken Walker & Strachan	1258	Fuel Emergency;	
Andrew McMullan & Co.	1258	Land	
Bruce M. Cook & Associates	1258		
Dwyer Mahon & Robertson	1258		
Ellinghaus Weill	1259		
Gray, Friend & Long	1259		
G.W.P. Aarons & Co.	1259		
Harris & Chambers	1260		
John Stewart	1260		
Juliano Furletti & Scott	1260		
Leddra Westmore & Co.	1260		
Mal. Ryan & Glen	1260		
Mills Oakley	1260		
Prior & Prior	1260		
T. J. Mulvany & Co.	1261		
Tolhurst Druce & Emmerson	1261		
Sales by the Sheriff			
Eric Tom	1261		
P. Vranic	1261		
Said Shaker	1261		
Unclaimed Moneys	1262		

Advertisers Please Note

As from 20 May 2004

The last Special Gazette was No. 117 dated 19 May 2004.

The last Periodical Gazette was No. 1 dated 12 June 2003.

How To Submit Copy

- See our webpage www.craftpress.com.au
 - or contact our office on 9926 1233
between 8.30 am and 5.30 pm Monday to Friday
-

Copies of recent Special Gazettes can now be viewed at the following display cabinets:

- 1 Treasury Place, Melbourne (behind the Old Treasury Building), and
 - Craftsman Press Pty Ltd, 125 Highbury Road, Burwood 3125
(front of building).
-

**PUBLICATION OF THE VICTORIA GOVERNMENT GAZETTE (GENERAL)
QUEEN'S BIRTHDAY**

Please Note:

The Victoria Government Gazette for Melbourne Cup week will be published on **Thursday 17 June 2004**.

Copy deadlines:

Private Advertisements **9.30 am on Friday 11 June 2004.**

Government and Outer

Budget Sector Agencies Notices **9.30 am on Tuesday 15 June 2004.**

Where urgent gazettal is required after hours, arrangements should be made with the Government Gazette Officer on 0419 327 321.

JENNY NOAKES
Government Gazette Officer

PRIVATE ADVERTISEMENTS

DISSOLUTION OF PARTNERSHIP

Take notice that the partnership which formerly existed between Dean King and Shewana Heni (aka Albert Heni), trading as Alberto's Hair Stylist, has been dissolved effective 20 March 2004.

DISSOLUTION OF PARTNERSHIP

Take notice that Uwe Tanzen and Helen Tanzen retired from the partnership of C&T Bricklaying of 15 Tara Close, Croydon, on 31 January 2004.

U. & H. Tanzen and L. & J. Cardaci, C/- AlphaStream Lawyers, 5A Hartnett Close, Mulgrave.

DISSOLUTION OF PARTNERSHIP

Notice is hereby given that the partnership previously subsisting between Vincent Lazzara and Kiersty Garbett, carrying on business developing investor relations sections of corporate websites at Studio 4, 249 Chapel Street, Prahran, Victoria, 3181 under the style or firm of IRonline, has been dissolved as from 8 April 2004.

Re: GLADYS ELIZABETH JOHNSTONE, late of 834 North Road, East Bentleigh, widow, deceased.

Creditors, next-of-kin and others having claims in respect of the estate of the deceased, who died on 24 February 2004, are required by the trustee, Equity Trustees Limited of Level 2, 575 Bourke Street, Melbourne, Victoria, to send particulars to the trustee by 22 July 2004 after which date the trustee may convey or distribute the assets, having regard only to the claims of which the trustee has notice.

AITKEN WALKER & STRACHAN, solicitors, 2nd Floor, 114 William Street, Melbourne 3000.

Creditors, next-of-kin and others having claims in respect of the estate of ELSIE MARGARET HENRY, deceased, late of 29-33 Chesterville Road, Glen Waverley, in the said State, home duties, who died on 21 March

2004, are required by Gwenn Margaret Brown, the proving executor of the Will of the deceased, to send particulars of their claim to Andrew McMullan & Co., solicitors, 64 Kingsway, Glen Waverley in the said State, solicitors for the executor of the said estate, ninety days from the date of this advertisement, after after which time the appointed executor will convey or distribute the assets having regard only to the claims of which she then has notice.

ANDREW McMULLAN & CO., solicitors, 64 Kingsway, Glen Waverley, Victoria.

Re: Estate of EDUARD RODGERS, deceased.

Creditors, next-of-kin or others having claims in respect of the estate of EDUARD RODGERS of "Mungeribar", 56-58 St George's Road, Beaconsfield Upper in the State of Victoria, travel agent, who died on 5 February 2004, are to send particulars of their claims to the personal representative/s care of the undermentioned solicitors by 29 July 2004 after which date the personal representative/s will distribute the assets having regard only to the claims of which they then had notice.

BRUCE M. COOK & ASSOCIATES, barristers & solicitors, Level 19, 535 Bourke St, Melbourne, Vic. 3000.

Re: Estate of WILBUR GORDON HOWCROFT.

Creditors, next-of-kin or others having claims in respect of the estate of WILBUR GORDON HOWCROFT, late of 42 Main Street, Culgoa in the State of Victoria, author, deceased, who died on 11 April 2004, are to send particulars of their claim to the executors care of the undermentioned legal practitioners by 30 July 2004 after which the executors will distribute the assets having regard only to the claims of which they then have notice.

DWYER MAHON & ROBERTSON, legal practitioners, Beveridge Dome, 194-208 Beveridge Street, Swan Hill.

Re: Estate of ROSA MOBILIO.

Creditors, next-of-kin or others having claims in respect of the estate of ROSA MOBILIO, late of 35 Splatt Street, Swan Hill in the State of Victoria, married woman, deceased, who died on 20 July 2001, are to send particulars of their claim to the administrator care of the undermentioned legal practitioners by 16 July 2004, after which the administrator will distribute the assets having regard only to the claims of which he then has notice.

DWYER MAHON & ROBERTSON,
legal practitioners,
Beveridge Dome, 194–208 Beveridge Street,
Swan Hill.

Re: Estate of STANLEY JOHN WATSON.

Creditors, next-of-kin or others having claims in respect of the estate of STANLEY JOHN WATSON, late of Wirrim Lodge, Taverner Street, Birchip in the State of Victoria, retired farmer, deceased, who died on 2 April 2004, are to send particulars of their claim to the executrices care of the undermentioned legal practitioners by 30 July 2004 after which the executrices will distribute the assets having regard only to the claims of which they then have notice.

DWYER MAHON & ROBERTSON,
legal practitioners,
Beveridge Dome, 194–208 Beveridge Street,
Swan Hill.

PATRICIA DAWN ARCHER, late of 4 Highland Avenue, Balwyn, cytotechnologist, deceased.

Creditors, next-of-kin and others having claims in respect of the estate of the deceased, who died on 31 January 2004, are required by the personal representatives, Geoffrey Henri Archer and Nola Isabel Archer both of 37 Crown Point Ridge, Chirnside Park to send particulars to them care of the undermentioned solicitors by 28 July 2004 after which date the personal representatives may convey or distribute the assets having regard only to the claims of which they then have notice.

ELLINGHAUS WEILL, solicitors,
79–81 Franklin Street, Melbourne 3000.

ARTHUR JOSEPH MURPHY, late of Grandview Lodge, Wycheproof, retired, deceased. Creditors, next-of-kin and others having claims in respect of the estate of the deceased, who died on 22 March 2004, are required by the personal representative, Hugh Leslie Murphy, of 10 Finch Avenue, Eaglehawk, to send particulars to him care of the undermentioned solicitors by 28 July 2004 after which date the personal representative may convey or distribute the assets having regard only to the claims of which he then has notice.

ELLINGHAUS WEILL, solicitors,
79–81 Franklin Street, Melbourne 3000.

LILA ALICE WHITE, late of Fairview Homes for the Aged Inc., widow, deceased.

Creditors, next-of-kin and others having claims in respect of the estate of the deceased, who died on 29 January 2004, are required by the trustee Gordon Burvill to send particulars of their claims to him care of the undersigned solicitors by 21 July 2004 after which date the trustee may convey or distribute the assets, having regard only to the claims of which he then has notice.

GRAY, FRIEND & LONG, solicitors,
70 Queen Street, Warragul 3820.

SOO SIEN HUANG (also known as Soo Sien Wahlqvist), late of 63 Canterbury Road, Middle Park in the State of Victoria, medical practitioner.

Creditors, next-of-kin and others having claims in respect of the estate of the abovenamed deceased, who died on 29 April 2004, are required by the executor of the Will of the deceased, Mark Lawrence Wahlqvist of 63 Canterbury Road, Middle Park in the State of Victoria, to send particulars of their claims to his solicitors GWP Aarons & Co. of Level 9, 224 Queen Street, Melbourne in the State of Victoria by 23 July 2004 after which date the executor may convey or distribute the assets having regard only to the claims of which he then has notice.

G. W. P. AARONS & CO., solicitors,
Level 9, 224 Queen Street, Melbourne,
Victoria 3000.

ALICE MAY HOUGH, late of 4 Tulip Grove, Cheltenham, tailoress, deceased.

Creditors, next-of-kin and others having claims in respect of the estate of the deceased, who died on 9 April 2004, are required by the trustees care of Harris & Chambers, lawyers of 338 Charman Road, Cheltenham, to send particulars to them by 20 July 2004 after which date the trustees may convey or distribute the assets, having regard only to the claims of which they then have notice.

HARRIS & CHAMBERS, lawyers,
338 Charman Road, Cheltenham 3192.

Creditors, next-of-kin and others having claims in respect of the Will of REGINALD GEORGE SMITH, late of 61 Illawarra Road, Flemington, Victoria, retired, deceased, who died on 27 May 2003, are requested to send particulars of their claims to the executors Jeffrey Graham Smith and Trevor Howard Smith, care of the undermentioned legal practitioner by 21 July 2004 after which date they will distribute the assets having regard only as to the claims of which they then have notice.

JOHN STEWART, legal practitioner,
290 Racecourse Road, Newmarket.

Creditors, next-of-kin and others having claims against the estate of PASQUALE CIRILLO, late of 8 Suffolk Avenue, Coburg, Victoria, carpenter, who died on 6 September 2003, are required to send particulars of their claims to the executor John De Masi care of the undermentioned solicitors before the expiration of two calendar months of the date of the publication of this notice after which date the executors will distribute the assets having regard only to the claims of which they then have notice.

JULIANO FURLETTI & SCOTT, solicitors,
Level 2, 19-21 Argyle Place South, Carlton,
Vic. 3053.

EUNICE MARY HOOPER, late of 10 The Boulevard, Heathmont, Victoria, sales assistant, deceased.

Creditors, next-of-kin and others having claims in respect of the estate of the deceased, who died on 10 December 2003, are required by the trustees, Yvonne Kopicwicz and Lauren Simon care Leddra Westmore & Co., 5A Station

Street, Mooroolbark, Victoria to send particulars to them by 23 July 2004 after which date the trustees may convey or distribute the assets having regard only to the claims of which they then have notice.

LEDDRA WESTMORE & CO.,
legal practitioners,
5A Station Street, Mooroolbark.

FRANK HAMLYN BLACKMORE, late of 52 Withers Lane, Mansfield, Victoria, retired.

Creditors, next-of-kin and others having claims in respect of the estate of the deceased, who died on 31 January 2004, are required by the applicants for grant of representation in the estate, Thomas Michael Rodney Ryan of 9 High Street, Mansfield, Victoria and Kenneth James Rutherford of 80 Main Street, Mairdample, Victoria, to send particulars to them at the office of the undermentioned firm of solicitors by 22 July 2004, after which date the applicants for grant of representation may convey and distribute the assets having regard only to the claims of which they then have notice.

MAL. RYAN & GLEN, solicitors,
2 High Street, Mansfield 3722.

PHYLLIS HAMILTON JOHNSTON, late of Unit 3, 23 Trentham Street, Sandringham, Victoria, spinster, deceased.

Creditors, next-of-kin and others having claims in respect of the estate of the deceased, who died on 29 April 2004, are required by the executor, ANZ Executors & Trustee Company Limited (ABN 33 006 132 332) of 530 Collins Street, Melbourne, Victoria to send particulars to it by 20 July 2004 after which date it may convey or distribute the assets having regard only to the claims of which it then has notice.

MILLS OAKLEY, lawyers,
121 William Street, Melbourne 3000.

ADAM LEE O'BRIEN, late of 34 Castlewood Street, Bentleigh East.

Creditors, next-of-kin and others having claims in respect of the estate of the deceased, who died on 26 April 2003, in Melbourne, Victoria are required by the administratrix Colleen Farrugia of 19 Wheatley Road, Bentleigh to send particulars to her within sixty days of the date of this advertisement after

which date the administratrix may convey or distribute the assets, having regard to the claims of which they then have notice.

PRIOR & PRIOR, solicitors,
335A Centre Road, Bentleigh.

FLORENCE LILLIAN JARVIS, late of 115 Kananook Avenue, Seaford, Victoria, home duties, deceased.

Creditors, next-of-kin and others having claims in respect of the estate of the abovenamed deceased, who died on 25 February 2004, are required to send particulars of their claims to the executor, John David Jarvis care of the undermentioned solicitors by 27 July 2004 after which date the said executor will distribute the assets having regard only to the claims of which he then has notice.

T. J. MULVANY & CO., solicitors,
2nd Floor, 51 Queen Street, Melbourne 3000.

Re: JOHN JOSEPH HUGHES, deceased. Creditors, next-of-kin and others having claims against the estate of JOHN JOSEPH HUGHES, late of 42A Darling Road, Malvern, Victoria, retired, deceased, who died on 20 July 2003, are required to send particulars of their claims to Perpetual Trustees Consolidated Limited of 360 Collins Street, Melbourne, Victoria, the executor of the said deceased, on or before 22 July 2004 after which date they will distribute the assets having regard only to the claims of which they then have notice.

TOLHURST DRUCE & EMMERSON,
lawyers,
520 Bourke Street, Melbourne.

In the Supreme Court of the State of Victoria
SALE BY THE SHERIFF

On Wednesday 23 June 2004 at 2.30 p.m. at the Sheriff's Office, 8-20 King Street, Oakleigh. (Unless process be stayed or satisfied).

All the estate and interest (if any) of Eric Tom of 2 Cranwell Mews, Skye as shown on Certificate of Title as Eric Vaopaaki Tom, proprietor of an estate in fee simple in the land described on Certificate of Title Volume 10553 Folio 143, upon which is erected a dwelling known as 2 Cranwell Mews, Skye.

Registered Mortgage No. X474114C and Covenant No. X474113F affect the said estate and interest.

Terms – Cash/Eftpos
(Debit Cards only. No Credit Cards).
SW-03-000802-9

Dated 20 May 2004

V. PARKIN
Sheriff's Office

In the Supreme Court of the State of Victoria
SALE BY THE SHERIFF

To the Highest Bidder at the Best Price Offered

On Wednesday 23 June 2004 at 2.30 p.m. at the Sheriff's Office, 8-20 King Street, Oakleigh. (Unless process be stayed or satisfied).

All the estate and interest (if any) of P. Vranic of 9 Marion Street, Dandenong as shown on Certificate of Title as Peter Drago Vranic, joint proprietor with Maria Vranic of an estate in fee simple in the land described on Certificate of Title Volume 7947 Folio 072, upon which is erected a dwelling known as 9 Marion Street, Dandenong.

Registered Queens Caveat No. AC751773M affects the said estate and interest.

No reserve set.

Terms – Cash/Eftpos
(Debit Cards only. No Credit Cards).
SW-03-002682-8

Dated 20 May 2004

V. PARKIN
Sheriff's Office

In the Supreme Court of the State of Victoria
SALE BY THE SHERIFF

On Wednesday 23 June 2004 at 2.30 p.m. at the Sheriff's Office, 8-20 King Street, Oakleigh. (Unless process be stayed or satisfied).

All the estate and interest (if any) of Said Shaker of 4 Raimeno Street, Lalor, proprietor of an estate in fee simple in the land described on Certificate of Title Volume 8481 Folio 609, upon which is erected a house known as 4 Raimeno Street, Lalor.

Registered Mortgage No. W877569X affects the said estate and interest.

Terms – Cash/Eftpos
(Debit Cards only. No Credit Cards).
SW-03-007159-8

Dated 20 May 2004

V. PARKIN
Sheriff's Office

Unclaimed Moneys Act 1962

Register of Unclaimed Moneys held by the —

<i>Name of Owner on Books and Last Known Address</i>	<i>Total Amount Due to Owner</i>	<i>Description Of Unclaimed Money</i>	<i>Date when Amount first became Payable</i>
AMERICAN HOME ASSURANCE COMPANY			
	\$		
Hoenniger Rainer, 50 Biddlecombe Avenue, Corio	150.00	Cheque	02/01/02
Dvora Glick, 503 Inkerman Road, Balaclava	134.32	"	08/01/02
Joshua Maxwell, 440 Collins Street, Melbourne	150.00	"	10/01/02
Eva Richard, PO Box 5418, Gladstone, Qld	355.00	"	16/01/02
Newcrest Mining Limited, C/- Marsh Pty Ltd, 555 Lonsdale Street, Melbourne	190.30	"	02/02/02
James Davis, C/- 510 Thomson Street, NSW	226.40	"	08/04/02
Sophie Reid, 45 Charles Street, Marrickville, NSW	150.00	"	10/04/02
James McAndrew, 59 Narrah Street, Alva Beach via Ayr, Qld	1,316.26	"	15/04/02
Andrew Abbey, 120–140 Pyrmont Street, Pyrmont, NSW	164.10	"	16/04/02
Bryan Cleaver, PO Box 1331, Parramatta, NSW	420.00	"	08/05/02
Nicolas Jaccard, 76 Old South Head Road, Bondi Junction, NSW	377.25	"	27/05/02
Fabrice Sbarro, 76 Old South Head Road, Bondi Junction, NSW	168.00	"	"
Gartner Australasia, Level 7, 40 Miller Street, North Sydney, NSW	4,778.21	"	29/05/02
Fu Pang Lee, C/- Update Ins Brokers PL, PO Box 834, Indooroopilly, Qld	6,255.18	"	"
Jack Koay, 41 Marton Crescent, Kings Langley, NSW	341.92	"	05/06/02
Don Raupita, 19 Kungala Street, Saint Marys, NSW	1,099.41	"	12/06/02
Boral Ltd, 50 Bridge Street, Sydney, NSW	1,220.58	"	13/06/02
Jan Duncan, 20 Lewina Drive, Daisy Hill, Qld	1,200.00	"	28/06/02
Asbed Abouljian, 18 Holt Street, North Ryde, NSW	500.00	"	"
Frances Whiriskey, 149 Mascoma Street, Strathmore	255.00	"	01/07/02
Partyka Sherrie, 2 Kirkwood Court, Castle Hill, NSW	250.00	"	11/07/02
Peter Tow, 9 The Crescent, Vacluse, NSW	115.00	"	31/07/02
Park Hyatt Sydney, C/- K. Dickson, Marsh Pty Ltd, PO Box H176, Australia Square, NSW	1,579.00	"	"
Karen Fitzgerald, PO Box 2146, Auckland, New Zealand	561.30	"	24/09/02
Harold Stevens, 411 Dryburgh Street, North Melbourne	675.00	"	26/09/02
E. G. B. Studdy, C/- Capital Steel Pipe, Suite 305, 107 Walker Street, Sydney, NSW	2,500.00	"	"
Philip Davis, 1st Floor, 200 Victoria Parade, East Melbourne	387.72	"	29/10/02

04096

CONTACT: ELIZABETH PALMIERI, PHONE: (03) 9522 4000.

Unclaimed Moneys Act 1962

Register of Unclaimed Moneys held by the —

<i>Name of Owner on Books and Last Known Address</i>	<i>Total Amount Due to Owner</i>	<i>Description Of Unclaimed Money</i>	<i>Date when Amount first became Payable</i>
AUSTEREO GROUP LIMITED			
	\$		
Ms Margaret Brown Ash, PO Box 2055, Milton, Qld	121.86	Cheque	15/11/02
Mr Andrew Carter, "A. G. Carter Super Fund A/c", 58 O'Briens Lane, Templestowe	731.34	"	"
Dandy Thompson Pty Ltd, 1/57 Byron Street, North Melbourne	225.50	"	"
Dandy Thompson Pty Ltd, 1/57 Byron Street, North Melbourne	170.00	"	26/04/02
Ms Tara Jeanne Hannon, 2/1 Highview Avenue, Neutral Bay, NSW	270.60	"	15/11/02
Ms Tara Jeanne Hannon, 2/1 Highview Avenue, Neutral Bay, NSW	204.00	"	26/04/02
Mr Brett Heath & Mrs Penelope Heath, "Heath Super Fund A/c", 17 Hortense Street, Glen Iris	243.77	"	15/11/02
Hillingdon Investments Pty Ltd, PO Box 8092, Preston	183.77	"	26/04/02
Mrs Letitia Hodgkinson, 12 Hughes Street, Brighton East	243.77	"	15/11/02
Mrs Letitia Hodgkinson, 12 Hughes Street, Brighton East	183.77	"	26/04/02
Mr George McCann, 93 Bennetts Road, Camp Hill, Qld	121.86	"	15/11/02
Mr Michael Francis O'Regan, 13 Billeroy Avenue, Baulkham Hills, NSW	487.53	"	"
Perpetual Nominees Pty Ltd, "M/Choice Andrew King A/c", PO Box 45, Collins Street West	183.77	"	26/04/02
Mr Edward Hopetoun Raggatt, PO Box 2, Semaphore, SA	157.85	"	15/11/02
R J Chalmers & Co Pty Ltd, "RJ CERF A/c", Unit 2, 273-275 Sussex Street, Sydney, NSW	243.77	"	"
Mrs Carol Stackpoole & Mr Brian Stackpoole, "Mackay Super Fund A/c", 117 Hume Street, Wodonga	243.77	"	"
Mrs Carol Stackpoole & Mr Brian Stackpoole, "Mackay Super Fund A/c", 117 Hume Street, Wodonga	183.77	"	26/04/02
Starbright Holdings Pty Ltd, "trading as Low Family Fund A/c", C/- Ms Dalvin Tan, PO Box 1168, Cloverdale, WA	121.86	"	15/11/02
Mr Joshua Virgona, 16 Buckland Avenue, Geelong	136.00	"	26/04/02
Est Mr Stuart John Wade, C/- Public Trustee of Qld, PO Box 131, Redcliffe, Qld	183.77	"	"
Wilson & Everard Pty Ltd, "Andrew Wilson Super Fund A/c", C/- Pitcher Partners, GPO Box 4193AA, Melbourne	275.67	"	"

04151

CONTACT: BERNAND HALILI, PHONE: (03) 9415 5000. EXT. 5724.

Unclaimed Moneys Act 1962

Register of Unclaimed Moneys held by the —

<i>Name of Owner on Books and Last Known Address</i>	<i>Total Amount Due to Owner</i>	<i>Description Of Unclaimed Money</i>	<i>Date when Amount first became Payable</i>
ARB CORPORATION LIMITED			
	\$		
DSP Management Pty Ltd, "Golden Fleece A/c", 6 Orlando Avenue, Mosman, NSW	320.00	Cheque	25/10/02
Mr Claus Ostergaard Nielsen & Mrs June Mary Nielsen, Stavangerparken 39, Bogense 5400, Denmark	130.00	"	"
Mrs Lyllian Agnes Percival, PO Box 487, Moree, NSW	200.00	"	"
Estate of Late Mable Elizabeth Smith, C/- Concorde Corporate Services, Suite 10, 83-87 Dover Street, Richmond	600.00	"	"
Estate of Late Mable Elizabeth Smith, C/- Concorde Corporate Services, Suite 10, 83-87 Dover Street, Richmond	375.00	"	26/04/02
Laurence William Wilson, PO Box 223, Sunbury	311.38	"	"

04134

CONTACT: KATHY MARK, PHONE: (03) 9415 5000. EXT. 5720.

Unclaimed Moneys Act 1962

Register of Unclaimed Moneys held by the —

<i>Name of Owner on Books and Last Known Address</i>	<i>Total Amount Due to Owner</i>	<i>Description Of Unclaimed Money</i>	<i>Date when Amount first became Payable</i>
CENTRAL EQUITY LIMITED			
	\$		
Margaret Barriball & Judith Ann Groome, PO Box 47410, Ponsonby, Auckland, New Zealand	240.00	Cheque	09/04/02
Major Griffith William Teck Brook, 424 Bluff Road, Hampton	138.00	"	12/12/02
Mrs Eleanor Joy Cameron, 34 Manuka Circle, Cherrybrook, NSW	180.00	"	09/04/02
Mr James Andrew Dickson, Unit 42, 400 Victoria Parade, East Melbourne	180.00	"	12/12/02

Mr James Andrew Dickson, Unit 42, 400 Victoria Parade, East Melbourne	180.00	”	20/09/02
Estate of Late Betty Eggleton, C/- J. Eggleton, 22 Linacre Road, Hampton	240.00	”	12/12/02
Halesworth Investments Pty Ltd, 8 Belinda Crescent, Wheelers Hill	132.00	”	10/07/02
Dr David Arthur Culbertson Hope & Ms Alison Kay Hope, “Hope Superannuation Account”, 50 Hindmarsh Square, Adelaide, SA	234.00	”	09/04/02
Kearney & Tyrrell Pty Ltd, 53 Rose Street, Essendon	300.00	”	”
Kearney & Tyrrell Pty Ltd, 53 Rose Street, Essendon	315.00	”	12/12/02
Kearney & Tyrrell Pty Ltd, 53 Rose Street, Essendon	315.00	”	10/07/02
Kearney & Tyrrell Pty Ltd, 53 Rose Street, Essendon	315.00	”	20/09/02
Kearney and Tyrrell Pty Ltd, 53 Rose Street, Essendon	300.00	”	09/04/02
Kearney and Tyrrell Pty Ltd, 53 Rose Street, Essendon	315.00	”	12/12/02
Kearney and Tyrrell Pty Ltd, 53 Rose Street, Essendon	315.00	”	10/07/02
Kearney and Tyrrell Pty Ltd, 53 Rose Street, Essendon	315.00	”	20/09/02
Mr Andrew Stewart Lang & Ms Judith Lynn Buchholz, “Titanga” Hml, Lismore	270.00	”	”
Le Land Pty Ltd, “Super Fund A/c”, 2 Oxford Street, Shoreham	171.00	”	09/04/02
Le Land Pty Ltd, “Super Fund A/c”, 2 Oxford Street, Shoreham	171.00	”	12/12/02
Le Land Pty Ltd, “Super Fund A/c”, 2 Oxford Street, Shoreham	171.00	”	10/07/02
Mr Shan Kau Samuel Lee & Ms Mei Ling Karen Kan, Unit 22A, Blk 1, Elegant Garden, 409–419 Queens Road W, Sai Ying Pun, Hong Kong	210.00	”	10/07/02
Dr Eric Maxwell, 30 Mickle Crescent, Warrnambool	180.00	”	12/12/02
Dr Eric Maxwell, 30 Mickle Crescent, Warrnambool	180.00	”	20/09/02
Mr Christopher John McBride, C/- Frank Hadley Pty Ltd, PO Box 50, Wee Waa, NSW	750.00	”	09/04/02
Reardon Investments Pty Ltd, 143 Nundle Road, Dungowan, NSW	504.00	”	10/07/02
Ms Connie Sheehan, 68 Freeman Street, North Fitzroy	180.00	”	12/12/02
United Video Hire Ltd, PO Box 75 518, Manurewa, Auckland, New Zealand	300.00	”	09/04/02
United Video Hire Ltd, PO Box 75 518, Manurewa, Auckland, New Zealand	300.00	”	10/07/02
United Video Hire Ltd, PO Box 75 518, Manurewa, Auckland, New Zealand	300.00	”	20/09/02
Mr Manuel Weiskopf, MD PSP, 4001 Hayvenhurst Drive, Encino, California, USA	450.00	”	10/07/02
Mr Manuel Weiskopf, 4001 Hayvenhurst Drive, Encino, California, USA	180.00	”	”
Mrs Pauline Whitehill, 100 Serpells Road, Templestowe	900.00	”	09/04/02

04140

CONTACT: VICKI VLAHOS, PHONE: (03) 9415 5000. EXT. 5719.

Unclaimed Moneys Act 1962

Register of Unclaimed Moneys held by the —

<i>Name of Owner on Books and Last Known Address</i>	<i>Total Amount Due to Owner</i>	<i>Description Of Unclaimed Money</i>	<i>Date when Amount first became Payable</i>
CORRS CHAMBERS WESTGARTH			
	\$		
Deposit at ANZ Bank Office A/c	755.00	Cheque	05/02
Ministry of Justice	682.41	"	08/02
Commonwealth Banking Corporation	200.00	"	"
Ministry of Justice	1,079.60	"	"
AON Ltd	128.06	"	01/03

04162

CONTACT: DEBBIE PATMORE, PHONE: (03) 9672 3000.

Unclaimed Moneys Act 1962

Register of Unclaimed Moneys held by the —

<i>Name of Owner on Books and Last Known Address</i>	<i>Total Amount Due to Owner</i>	<i>Description Of Unclaimed Money</i>	<i>Date when Amount first became Payable</i>
CPI GROUP LIMITED			
	\$		
The A. L. Lane Foundation, 177 Koroit Street, Warnambool	1,324.80	Cheque	01/07/02
Mr Robert Franklin Garton & Mrs Mary Garton, 19 Wyomee Avenue, Pymble, NSW	220.80	"	31/12/02
Gelsomino Pty Limited, "Hector Retirement Fund A/c", PO Box 1180, Bathurst, NSW	772.80	"	01/07/02
Lockerbie Pty Ltd, "Slaughter Superannuation A/c", C/- P. J. Slaughter, 37 Munro Street, Auchenflower, Qld	220.80	"	31/12/02
Mr Alar Raam, PO Box 1065, Cronulla, NSW	441.60	"	"
Mr Alar Raam, PO Box 1065, Cronulla, NSW	441.60	"	01/07/02
Mr Peter James Roebig & Mr Gerald John Meyn & Mr Colin John Crow, "Sabae Super Fund A/c", 4 Cochrane Street, Paddington, Qld	220.80	"	31/12/02
Mr Peter James Roebig & Mr Gerald John Meyn & Mr Colin John Crow, "Sabae Super Fund A/c", 4 Cochrane Street, Paddington, Qld	220.80	"	01/07/02
Mr Neal Currie Watt & Mrs Aafke Gezina McPhie, "Watt & McPhie Superfund A/c", PO Box 1011, Mossman, Qld	110.40	"	31/12/02

04135

CONTACT: CONTACT: KATHY MARK, PHONE: (03) 9415 5000. EXT. 5720.

Unclaimed Moneys Act 1962

Register of Unclaimed Moneys held by the —

<i>Name of Owner on Books and Last Known Address</i>	<i>Total Amount Due to Owner</i>	<i>Description Of Unclaimed Money</i>	<i>Date when Amount first became Payable</i>
CPT GLOBAL LIMITED			
	\$		
Alphaomega Consulting Pty Ltd, 3 Silver Birch Close, Croydon Hills	153.33	Cheque	04/10/02
Ms Carrol Jane Burt, 2/297–299 St Kilda Street, Brighton	161.25	”	22/02/02
Empire Solutions Pty Ltd, PO Box 1336, Geelong	260.00	”	04/10/02
Paul Joseph Hangartner, 20 St Matthews Road, Kingsdown, Bristol B26 5TS, UK	487.70	”	”
Mr Mark Kendall, Unit 3, 787 Elgar Road, Doncaster	372.50	”	”
Mr Bill Patterson, 32 The Boulevard, Heathmont	108.75	”	22/02/02
Mr Hal Pringle, 5 Edlington Street, Hawthorn	125.01	”	”
04153			
CONTACT: BERNARD HALILI, PHONE: (03) 9415 5000. EXT: 5724.			

Unclaimed Moneys Act 1962

Register of Unclaimed Moneys held by the —

<i>Name of Owner on Books and Last Known Address</i>	<i>Total Amount Due to Owner</i>	<i>Description Of Unclaimed Money</i>	<i>Date when Amount first became Payable</i>
DIVERSIFIED UNITED INVESTMENT LTD			
	\$		
Mr Peter Andrew Barry, 15 Mileham Street, MacGregor, ACT	156.25	Cheque	11/04/02
Ms Gay Blahovec, 29 Kerferd Street, East Malvern	282.00	”	09/10/02
Ms Gay Blahovec, 29 Kerferd Street, East Malvern	176.25	”	11/04/02
Estate of Late Hans Kiehne, C/- Schweizer Kobras, PO Box H283, Australia Square, NSW	250.00	”	09/10/02
Estate of Late Hans Kiehne, C/- Schweizer Kobras, PO Box H283, Australia Square, NSW	156.25	”	11/04/02
Mrs Helen Emma Ray, PO Box 462, Benalla	125.00	”	”
Ms Joanna Ryan, Unit 102, 461 St Kilda Road, Melbourne	100.00	”	”
Mr Edward William John Wickham, 4/12 Station Street, East Kew	200.00	”	09/10/02
Mr Matthew Alexander Munro Wickham, Unit 1, Caroline Street, South Yarra	400.00	”	”

Mr Matthew Alexander Munro Wickham,
Unit 1, Caroline Street, South Yarra 250.00 " 11/04/02

04118

CONTACT: CAROL ROLLMAN, PHONE: (03) 9415 5000. EXT. 5727.

Unclaimed Moneys Act 1962

Register of Unclaimed Moneys held by the —

<i>Name of Owner on Books and Last Known Address</i>	<i>Total Amount Due to Owner</i>	<i>Description Of Unclaimed Money</i>	<i>Date when Amount first became Payable</i>
GOLDMAN SACHS JBWERE CAPITAL MARKETS LTD			
\$			
Australian-American Association Inc, Level 1, 401 Collins Street, Melbourne	368.98	Cheque	03/09/02
Mrs Shirley Jean Cameron, "Pension Fund A/c", Level 15, 309 Kent Street, Sydney, NSW	897.05	"	15/03/02
Mrs Shirley Jean Cameron, "Pension Fund A/c", Level 15, 309 Kent Street, Sydney, NSW	799.45	"	03/09/02
Mrs Shirley Jean Cameron, "Pension Fund A/c", Level 15, 309 Kent Street, Sydney, NSW	573.42	"	31/12/02
Mrs Shirley Jean Cameron, "Pension Fund A/c", Level 15, 309 Kent Street, Sydney, NSW	564.08	"	01/07/02
Mrs Sandra Jane Campbell, "Gregory W Walshe A/c", 9 Mallee Place, Rivett, ACT	697.91	"	03/09/02
Ms Elizabeth Scott Coombe, "E. S. Coombe Super A/c", GPO Box 814, Adelaide, SA	6,231.86	"	02/04/02
Ms Nora Marjorie Firth, C/- Mr Peter Bull, PO Box 292, Pymble, NSW	3,598.23	"	03/09/02
Mr Harry Kalinski & Mrs Eva Kalinski, "Superannuation Fund A/c", 2/26 Frogmore Road, Carnegie	114.68	"	31/12/02
Malvol Pty Ltd, "Male Family Super Fund A/c", PO Box 425, Wangaratta	138.01	"	15/03/02
Miss Nicole Louise Mayne, 3/2877 Gold Coast Highway, Surfers Paradise, Qld	6,231.86	"	02/04/02
Miss Muriel Lyell McAlpine, 78 Boundary Street, Roseville, NSW	966.06	"	15/03/02
Miss Muriel Lyell McAlpine, 78 Boundary Street, Roseville, NSW	860.94	"	03/09/02
Melshare Nominees Pty Ltd, GPO Box 1392M, Melbourne	9,522.57	"	15/03/02

04137

CONTACT: KATHY MARK, PHONE: 9415 5000. EXT. 5720.

Unclaimed Moneys Act 1962

Register of Unclaimed Moneys held by the —

<i>Name of Owner on Books and Last Known Address</i>	<i>Total Amount Due to Owner</i>	<i>Description Of Unclaimed Money</i>	<i>Date when Amount first became Payable</i>
GUD HOLDINGS LIMITED			
	\$		
Arcadia Bay Pty Ltd, "Arcadia Bay S/F A/c", 13 Molan Street, Ringwood	525.00	Cheque	30/04/02
Francis Peter Bannon, 18 Alexandra Street, Hunter's Hill, NSW	110.79	"	13/09/02
Miss Sally Elizabeth Bartlett, 8 Lotus Crescent, Mulgrave	135.00	"	"
Miss Sally Elizabeth Bartlett, 8 Lotus Crescent, Mulgrave	112.50	"	30/04/02
Mr Neville William Beer & Mrs June Patricia Beer, 2/8 Moonah Way, Mount Martha	225.00	"	"
Mr Richard Edward Burke, 7 Barnsbury Road, Balwyn	173.70	"	13/09/02
Mrs Tracey Lea Delandre, 2 Trevenen Court, Jan Juc	158.58	"	"
Mr Agostino Di Ruocco, 6 Rainbow Street, Wentworthville, NSW	162.00	"	"
Mr Agostino Di Ruocco, 6 Rainbow Street, Wentworthville, NSW	135.00	"	30/04/02
Mrs Maria Magdalena Edwards, 120 Woronora Parade, Oatley, NSW	110.70	"	13/09/02
G. & M. Tyquin No. 1 Pty Ltd, "Superannuation Fund A/c", 4 Venice Street, Box Hill South	135.00	"	"
Mr Alastair Garth Gibson & Mrs Leanne Margaret Gibson, "A. G. Gibson Super Fund A/c", 2 Bellaview Road, Flagstaff Hill, SA	290.50	"	30/04/02
Mr Robin Keay Grant, 64 Davey Street, Parkdale	180.00	"	13/09/02
Mrs Jean Merle Iles, C/- Lindsay Iles & Co, 2/105 Queen Street, Melbourne	450.00	"	"
Mrs Christine Margaret Jago, 60 Faye Road, Bellmere, Qld	261.00	"	"
Ms Linda Kilsby, 13 Waterhouse Street, Curtin, ACT	120.06	"	"
Ms Li Liu, 20/222 Church Street, North Parramatta, NSW	270.00	"	"
Ms Li Liu, 20/222 Church Street, North Parramatta, NSW	116.00	"	30/04/02
The MJD Holdings Pty Ltd, "Superannuation Fund A/c", 38A Epping Drive, Frenchs Forest, NSW	225.00	"	13/09/02
The MJD Holdings Pty Ltd, "Superannuation Fund A/c", 38A Epping Drive, Frenchs Forest, NSW	187.50	"	30/04/02
Mr Wayne Ronald Morgan & Mrs Lucy Morgan, "Morgan Super Fund A/c", C/- SAI Fund Administrators, PO Box 6147, Doncaster	250.92	"	13/09/02
Mr Nathaniel Neden, 4 Merton Place, Albert Park	108.00	"	"

Mr Tony Perri, 3/3 Rennison Street, Parkdale	135.00	''	''
Ms Peta Signe, The Vice Den, 12 Horton Hill, Epsom, Surrey KT19 8SS, United Kingdom	150.03	''	''
Ms Peta Signe, The Vice Den, 12 Horton Hill, Epsom, Surrey KT19 8SS, United Kingdom	107.03	''	30/04/02
Mrs Jane Francis Trevor Thompson, RMB 337, Burra Road, Gundagai, NSW	990.00	''	13/09/02
Mrs Jane Francis Trevor Thompson, RMB 337, Burra Road, Gundagai, NSW	825.00	''	30/04/02
Mr Jason Thompson & Mrs Jenny Thompson, 267 Wade Avenue, Mildura	106.20	''	13/09/02
Mr Rodney John Thorpe, 511 The Boulevard, East Ivanhoe	188.82	''	''
Mr Rodney John Thorpe, 511 The Boulevard, East Ivanhoe	157.35	''	30/04/02
W. M. Ritchie Services Pty Ltd, PO Box 222, Waterloo, NSW	2,700.00	''	13/09/02
Miss Ann Mary Woodruff, 9 Carlyle Street, East Hawthorn	185.03	''	30/04/02

04138

CONTACT: KATHY MARK, PHONE: 9415 5000. EXT. 5720.

Unclaimed Moneys Act 1962

Register of Unclaimed Moneys held by the —

<i>Name of Owner on Books and Last Known Address</i>	<i>Total Amount Due to Owner</i>	<i>Description Of Unclaimed Money</i>	<i>Date when Amount first became Payable</i>
FUNTASTIC LIMITED			
	\$		
Abacus London Limited, "T Account", PO Box 18160, Collins Street East	300.00	Cheque	15/10/02
Mrs Lucy Bond, "Lucy Ellen Bond S/Fund A/c", 15 Beluga Street, Mount Eliza	120.00	''	''
Mr William Dodds & Mrs Edwina Sinclair Dodds, 71 Bonito Street, Corlette, NSW	150.00	''	''
Mr David Graham Hendy, "Christian Hendy A/c", 65 Comer Street, East Brighton	150.00	''	''
Mr Michael Horne, 19 Beverley Street, Scoresby	150.00	''	''
Neilstock Nominees Pty Ltd, "Capital Stockbrokers A/c", GPO Box 1035, Brisbane, Qld	952.50	''	''
Mr Lance Robinson, 61-63 Knees Road, Park Orchards	150.00	''	''
Mr Anthony David Seaman, 5 Clement Street, Plympton Park, SA	118.80	''	''
Mr James Stack, 271 Harcourt Street, New Farm, Qld	120.00	''	''

04136

CONTACT: KATHY MARK, PHONE: 9415 5000. EXT. 5720.

Unclaimed Moneys Act 1962

Register of Unclaimed Moneys held by the —

<i>Name of Owner on Books and Last Known Address</i>	<i>Total Amount Due to Owner</i>	<i>Description Of Unclaimed Money</i>	<i>Date when Amount first became Payable</i>
INVESTOR GROUP LIMITED			
\$			
Apropos Pty Ltd, "Murray & Allen S/Fund A/c", C/- PO Box 660, Armidale, NSW	849.81	Cheque	05/11/02
John Richard Britton, C/- Byron Moore Journeaux Ltd, 257 Collins Street, Melbourne	412.50	"	"
John Richard Britton, C/- Byron Moore Journeaux Ltd, 257 Collins Street, Melbourne	337.50	"	03/05/02
Mr Rob Camilleri, C/- Investor Financial Planning, PO Box 1132, Camberwell	275.00	"	05/11/02
Mr Rob Camilleri, C/- Investor Financial Planning, PO Box 1132, Camberwell	225.00	"	03/05/02
Ms Abi Cleland, 35/2 Macarthur Road, Parkville	275.00	"	05/11/02
Ms Abi Cleland, 35/2 Macarthur Road, Parkville	225.00	"	03/05/02
Extol Australia Pty Ltd, 14 Lysterville Avenue, Malvern	225.00	"	"
Mr Shane Andrew Gibson & Ms Tracey Maree Gibson, "Ingodive A/c", C/- Cook Adam & Co, PO Box 1109, Invercargill, New Zealand	2,480.99	"	"
Jampac Investments Pty Ltd, C/- PPP, PO Box 47, Highett	550.00	"	05/11/02
Jampac Investments Pty Ltd, C/- PPP, PO Box 47, Highett	450.00	"	03/05/02
Johlon Pty Limited, Retireinvest, PO Box 5191, Newcastle, NSW	113.47	"	05/11/02
Ms Nadia Little, 13 Highfield Avenue, Berwick	107.42	"	"
Mrs Elizabeth Loughnan, 21 Canterbury Road, Toorak	137.50	"	"
Mrs Elizabeth Loughnan, 21 Canterbury Road, Toorak	112.50	"	03/05/02
Lucet Jan Nominees Pty Ltd, "Lucet Jan Super Fund A/c", PO Box 58, Patchewollock	139.15	"	05/11/02
Perbright Pty Ltd, "J. G. & C. M. Reid S/F A/c", 525 Raglan Parade, Warrnambool	233.20	"	"
Perbright Pty Ltd, "J. G. & C. M. Reid S/F A/c", PO Box 3103, Mildura	172.43	"	"
Perbright Pty Ltd, "J. G. & C. M. Reid S/F A/c", PO Box 3103, Mildura	141.08	"	03/05/02
Refdam Proprietary Ltd, PO Box 541, Double Bay, NSW	467.50	"	05/11/02
Slab Investments Pty Limited, "Super Fund A/c", PO Box 14, Ballina, NSW	100.16	"	"
Mrs Fiona Kim Smith, 141 Seaview Road, Tennyson, SA	110.00	"	"

Mr Mark Uchtman & Ms Cherrie Tulloch, "Uchtman Superfund A/c", PO Box 3049, Mildura	275.00	"	"
Mr Mark Uchtman & Ms Cherrie Tulloch, "Uchtman Superfund A/c", PO Box 3049, Mildura	225.00	"	03/05/02

04129

CONTACT: CAROL ROLLMANN, PHONE: (03) 9415 5000. EXT. 5727.

Unclaimed Moneys Act 1962

Register of Unclaimed Moneys held by the —

<i>Name of Owner on Books and Last Known Address</i>	<i>Total Amount Due to Owner</i>	<i>Description Of Unclaimed Money</i>	<i>Date when Amount first became Payable</i>
LATROBE CITY COUNCIL			
	\$		
Mr Kevin Mills, 2 Grant Street, Morwell	135.00	Cheque	15/04/02
Vann Fisher & Associates, PO Box 631, Lilydale	440.61	"	20/05/02
Graham Gehrke, C/- Vann Fisher & Associates, PO Box 631, Lilydale	150.00	"	"

04181

CONTACT: ROSA AGOSTINO, PHONE: (03) 5176 3517
SARAH MORGAN, PHONE: (03) 5176 3547.**Unclaimed Moneys Act 1962**

Register of Unclaimed Moneys held by the —

<i>Name of Owner on Books and Last Known Address</i>	<i>Total Amount Due to Owner</i>	<i>Description Of Unclaimed Money</i>	<i>Date when Amount first became Payable</i>
NATIONAL CAN INDUSTRIES LIMITED			
	\$		
Mr Reginald Bernard Barton, "No. 10 A/c", PO Box 484, Roseville, NSW	123.75	Cheque	31/10/02
Mrs Wendy Jane Davidson, 25 Cook Crescent, Dysart, Qld	112.50	"	"
Mr Trenton Roy McCurley, 8 Porters Road, Kenthurst, NSW	100.00	"	"
Estate of Late Ivor William Meldrum, C/- Russell Kennedy, PO Box 5146AA, Melbourne	247.50	"	"
Mr Barry Sladden Peterson, 6 Chatham Road, Canterbury	144.38	"	"

04149

CONTACT: BERNARD HALILI, PHONE: (03) 9415 5000. EXT: 5724.

Unclaimed Moneys Act 1962

Register of Unclaimed Moneys held by the —

<i>Name of Owner on Books and Last Known Address</i>	<i>Total Amount Due to Owner</i>	<i>Description Of Unclaimed Money</i>	<i>Date when Amount first became Payable</i>
PROGRAMMED MAINTENANCE SERVICES LTD			
\$			
Mr Robin Bishop & Ms Gillian Turner, "Dragon Super Fund A/c", 2/66 King Street, Sydney, NSW	100.00	Cheque	25/07/02
Mr Robin Bishop & Ms Gillian Turner, "Dragon Super Fund A/c", 2/66 King Street, Sydney, NSW	100.00	"	24/01/02
Mr Peter James Hayman, C/- J. P. Morgan Securities Aust, Level 25, Grosvenor Place, 225 George Street, Sydney, NSW	515.00	"	25/07/02
Mr Nigel Melville Raynes Houston, 2 Hean Street, South Hobart, Tas.	116.00	"	"
Lynedoch Pty Ltd, PO Box 375, Yamba, NSW	400.00	"	"
Markyle Pty Ltd, 5/96 Oxlade Drive, New Farm, Qld	1,000.00	"	"
Milai Pty Ltd, "The Milai P/L Defactor A/c", PO Box A282, Sydney South, NSW	1,592.68	"	"
Mrs Rowena Theresa Monks, 13 Alwyn Street, Croydon	140.00	"	"
Mr Bruce Patterson, 1/122 Grafton Road, Roseneath, Wellington, New Zealand	179.00	"	"
Mr Bruce Patterson, 1/122 Grafton Road, Roseneath, Wellington, New Zealand	179.00	"	24/01/02
Miss Pauline Frances Grenfell Price, PO Box 261, Prospect LPO, Prospect, SA	120.00	"	"
Mrs Wendy Tai, 69 Cairnhill Road, 14-75 229675, Singapore	340.00	"	"
Mrs Sandra Turton, 92 Trevoise Crescent, Singapore 298080	170.00	"	24/01/02
Mr Hamish Tweedy, 5/6 McDougall Street, Kirribilli, NSW	160.00	"	"
Ms Nerida White, "Nerida White S/F A/c", 1/22 Raglan Street, North Melbourne	180.00	"	25/07/02

04154

CONTACT: BERNARD HALILI, PHONE: (03) 9415 5000. EXT: 5724.

Unclaimed Moneys Act 1962

Register of Unclaimed Moneys held by the —

<i>Name of Owner on Books and Last Known Address</i>	<i>Total Amount Due to Owner</i>	<i>Description Of Unclaimed Money</i>	<i>Date when Amount first became Payable</i>
TEMPLETON GLOBAL GROWTH FUND LIMITED			
\$			
Mr Erwin Clayton & Mrs Mary Clayton, "Clayton Family A/c", 21 Cherrybrook Road, West Pennant Hills, NSW	300.00	Cheque	22/03/02
Mrs Doina Lydia Dascalu, PO Box 794, Potts Point, NSW	108.00	"	"
Mrs Jane Littleton Grose, 168 Jeffcott Street, North Adelaide, SA	270.00	"	27/09/02
Mrs Jane Littleton Grose, 168 Jeffcott Street, North Adelaide, SA	270.00	"	22/03/02
Professor Henry Paul Krips, 1117 Cathedral of Learning, Pittsburgh PA 15260, USA	266.01	"	27/09/02
Ms Patricia Ann Lawrie, C/- Tower Trust Limited, GPO Box 465, Adelaide, SA	150.00	"	22/03/02
Sister Eileen T. O'Sullivan, C/- Mr & Mrs J. Robson, "Knockwood", 1 Bents Basin Road, Wallacia, NSW	240.00	"	27/09/02
Ms Elizabeth Ann Pearson, 59 Cygnet Crescent, Red Hill, ACT	150.00	"	"
Perpetual Trustees Cons Ltd, "Larke Family S/Fund A/c", Merrills, C/- Perpetual P/Folio Services, GPO Box 5106, Sydney, NSW	417.00	"	22/03/02
Ms Daphne Ann Roberts, 5/13-17 Llewellyn Street, Rhodes, NSW	120.00	"	27/09/02

04132

CONTACT: CAROL ROLLMANN, PHONE: (03) 9415 5000. EXT. 5727.

PROCLAMATIONS

ACTS OF PARLIAMENT

Proclamation

I, John Landy, Governor of Victoria, declare that I have today assented in Her Majesty's name to the following Bills:

No. 13/2004 **Commonwealth Games Arrangements (Further Amendment) Act 2004**

No. 14/2004 **Corrections (Further Amendment) Act 2004**

No. 15/2004 **Crimes (Assumed Identities) Act 2004**

No. 16/2004 **Crimes (Controlled Operations) Act 2004**

No. 17/2004 **Estate Agents and Travel Agents Acts (Amendment) Act 2004**

No. 18/2004 **Health Services (Supported Residential Services) Act 2004**

No. 19/2004 **Heritage (Further Amendment) Act 2004**

No. 20/2004 **Justice Legislation (Sexual Offences and Bail) Act 2004**

No. 21/2004 **Land (Miscellaneous) Act 2004**

No. 22/2004 **Primary Industries Legislation (Miscellaneous Amendments) Act 2004**

No. 23/2004 **Transfer of Land (Electronic Transactions) Act 2004**

Given under my hand and the seal of Victoria at Melbourne on 18 May 2004.

(L.S.) JOHN LANDY
Governor
By His Excellency's Command
STEVE BRACKS MP
Premier

No. 13/2004 **Commonwealth Games Arrangements (Further Amendment) Act 2004**

This Act comes into operation on the day after the day on which it receives the Royal Assent.

No. 14/2004 **Corrections (Further Amendment) Act 2004**

(1) Subject to sub-section (2), this Act comes into operation on a day or days to be proclaimed.

(2) If a provision of this Act does not come into operation on or before 30 August 2004, it comes into operation on that day.

No. 15/2004 **Crimes (Assumed Identities) Act 2004**

This Act comes into operation on a day or days to be proclaimed.

No. 16/2004 **Crimes (Controlled Operations) Act 2004**

This Act comes into operation on a day or days to be proclaimed.

No. 17/2004 **Estate Agents and Travel Agents Acts (Amendment) Act 2004**

(1) This Act (other than Part 3) comes into operation on the day after the day on which it receives the Royal Assent.

(2) Part 3 comes into operation on a day to be proclaimed.

(3) If Part 3 does not come into operation before 1 January 2005, it comes into operation on that day.

No. 18/2004 **Health Services (Supported Residential Services) Act 2004**

(1) Subject to sub-section (2), this Act comes into operation on a day or days to be proclaimed.

(2) If a provision referred to in sub-section (1) does not come into operation before 31 December 2004, it comes into operation on that day.

No. 19/2004 **Heritage (Further Amendment) Act 2004**

This Act comes into operation on the day after the day on which it receives the Royal Assent.

No. 20/2004 **Justice Legislation (Sexual Offences and Bail) Act 2004**

This Act comes into operation on the day after the day on which it receives the Royal Assent.

No. 21/2004 **Land (Miscellaneous) Act 2004**

This Act comes into operation on the day after the day on which it receives the Royal Assent.

No. 22/2004 **Primary Industries Legislation (Miscellaneous Amendments) Act 2004**

- (1) This Act, except sections 22 to 26, 28 and 29, comes into operation on the day after the day on which it receives the Royal Assent.
- (2) Subject to sub-section (3), the remaining provisions of this Act come into operation on a day or days to be proclaimed.
- (3) If a provision referred to in sub-section (2) does not come into operation before 1 January 2005, it comes into operation on that day.

No. 23/2004 **Transfer of Land (Electronic Transactions) Act 2004**

This Act comes into operation on the day after the day on which it receives the Royal Assent.

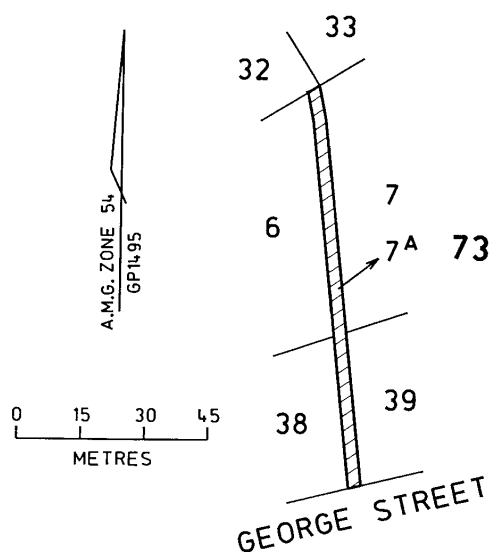

This Proclamation is effective from the date on which it is published in the Government Gazette.

Given under my hand and the seal of
Victoria on 18th May 2004.

(L.S.) JOHN LANDY
Governor
By His Excellency's Command
MARY DELAHUNTY, MP
Minister for Planning

Land Act 1958

PROCLAMATION OF ROAD

I, John Landy, Governor of Victoria with the advice of the Executive Council and under section 25(3)(c) of the **Land Act 1958** proclaim as road the following land:

MUNICIPAL DISTRICT OF THE
CITY OF BALLARAT

BALLARAT EAST — The land in the Township of Ballarat East, Parish of Ballarat, being Crown Allotment 7A, Section 73, as shown by hatching on plan hereunder. (GP1495) — (05P101533)

**GOVERNMENT AND OUTER BUDGET
SECTOR AGENCIES NOTICES**



Notice of Road Deviation

In pursuance of Section 2(2)(b) of Schedule 10 of the **Local Government Act 1989**, Council has formed the opinion that the unused Government road shown by hatching on the plan below is not reasonably required as a road and has resolved to deviate the road over the land shown cross-hatched on the plan being part of Crown Allotment 8, Section D, Township of Bairnsdale, and having complied with Section 223 of the Act and having obtained the consent of the Minister for Planning for such deviation, now declares such deviation for the purposes of the Act on and from the publication of this notice in the Government Gazette.

This notice replaces the Notice of Road Discontinuance which was published in the Victoria Government Gazette dated 17 July 2003 at page 1793 which is hereby rescinded.

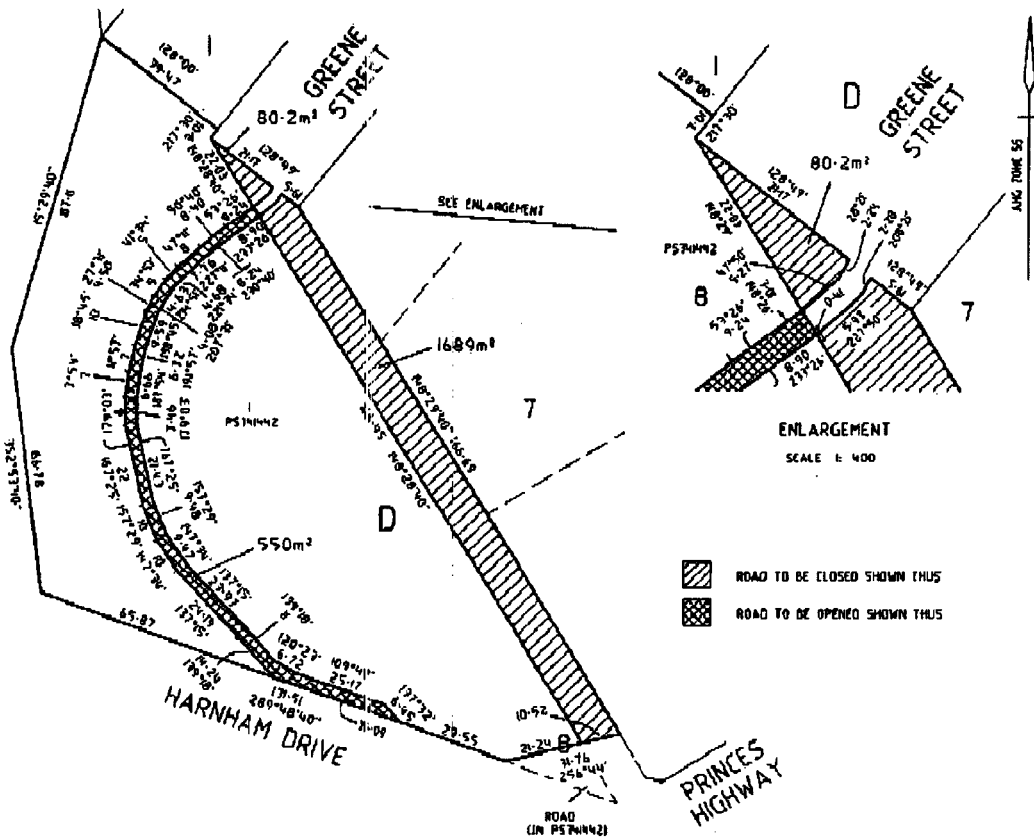

STEVE KOZLOWSKI
Chief Executive Officer



Discontinuance of Road

Pursuant to Section 206 and to Schedule 10, Clause 3 of the **Local Government Act 1989**, Greater Dandenong City Council, at its ordinary meeting of 13 April 2004, formed the opinion the road created in the Victorian Government Gazette No. 68, August 10 1977 on page 2598 and being part of Lot 17 LP 70375, contained in Certificate of Title Volume 8646 Folio 306 and shown bounded by bold lines and hatched on the plan below, is not reasonably required as a road for public use and resolved to discontinue the road. The land is to be retained by Greater Dandenong City Council.

In accordance with Section 207C of the **Local Government Act 1989** any right, power or interest held by a public authority in the discontinued road in connection with any sewer, drains, pipes, wires and cables under the control of the authority in or near the road is preserved.

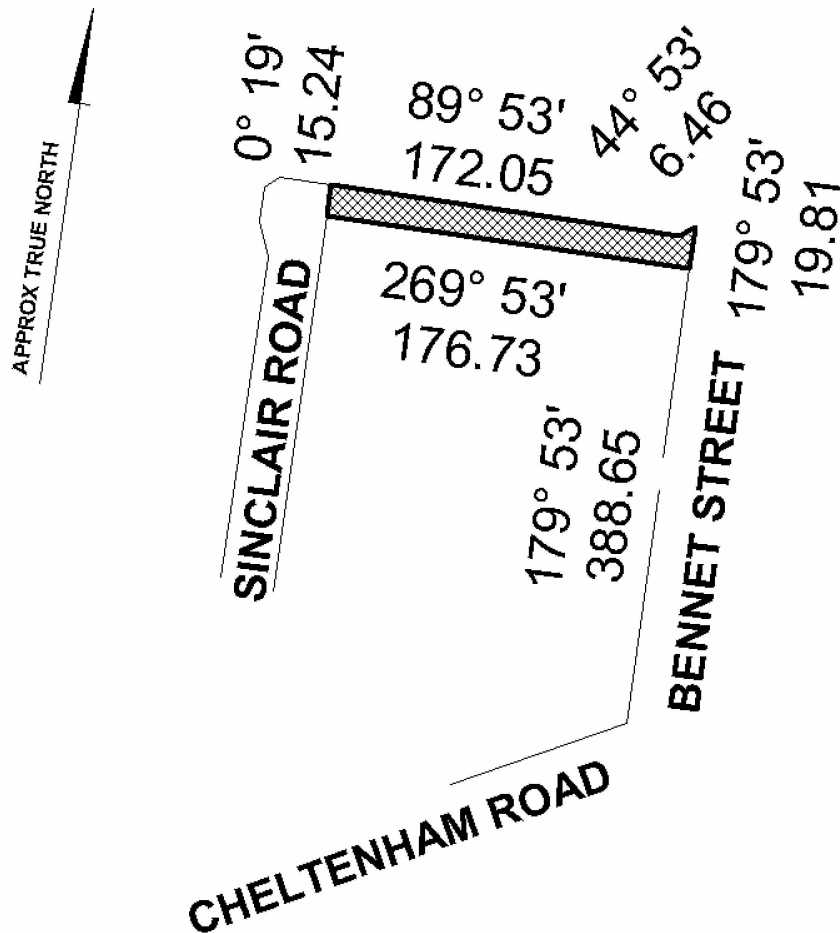

WARWICK HEINE
Chief Executive Officer



Discontinuance and Sale of a Section of
Unused Roadway between Nabilla Avenue and Railway Parade, Seaford

Notice is hereby given that the Frankston City Council being of the opinion that the section of roadway between Nabilla Avenue and Railway Parade, Seaford as shown hatched on Council Plan No. M472A below is not required for public use and having complied with the provisions of Clause 3 of Schedule 10 of the **Local Government Act 1989** (the Act) resolved that the said section of the unused roadway be discontinued and sold by private treaty to the owners of the abutting properties.

South East Water will continue to have and possess the same power, authority or interest in or in relation to the land shown on the said plan, as it had or possessed prior to such discontinuance with respect to or in connection with any pipes laid or erected in, on or over such land for sewerage purposes.

Frankston City Council will continue to have and possess the same power, authority or interest in or in relation to the land shown on the said plan, as it had or possessed prior to such discontinuance with respect to or in connection with any pipes laid or erected in, on or over such land for the purposes of drainage.

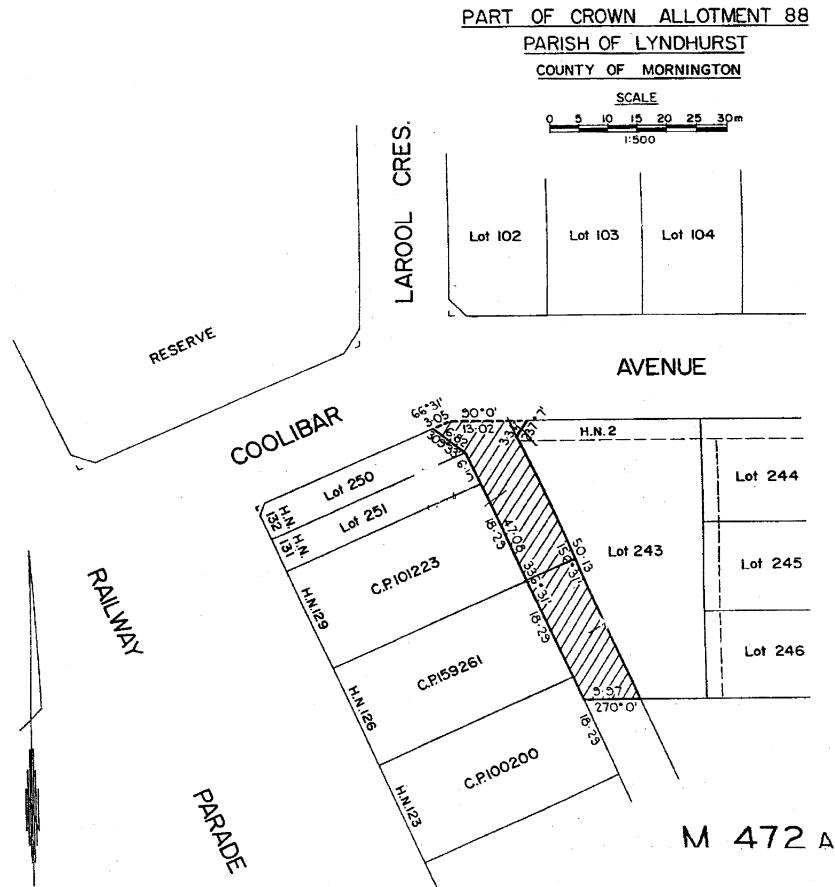

STEVE GAWLER
Chief Executive Officer



NAMING OF FORMER MONTEREY HIGH SCHOOL SITE
 Monterey Boulevard, Frankston

At its meeting on 9 March, 2004, Council resolved to name the above school site 'Monterey Community Park'.

Council also resolved to name a feature of the park, when it is developed, after Kathleen Neilsen in recognition of her longstanding community involvement.

STEVE GAWLER
 Chief Executive Officer

SOUTH GIPPSLAND SHIRE COUNCIL
 Road Deviation and
 Declaration as a Public Highway

At its meeting on 17 September 2003 and under section 206 and Schedule 10, Clause 2 of the **Local Government Act 1989** ("the Act"), the South Gippsland Shire Council formed the opinion that the road shown crosshatched on the plan below is not reasonably required as a road for public use and resolved to discontinue the road and to deviate the road through private land shown hatched on the plan, and further formed the opinion that the deviated road is required to be opened to the public for traffic as a right, and under section 204(1) of the Act declared the road to be a public highway for the purpose of the Act on and from publication of this notice in the Government Gazette.

PLAN OF ROAD EXCHANGE
 DOLLAR – WOORARRA WEST ROAD, FOSTER
 COUNTY OF BULN BULN
 PARISH OF MIRBOO SOUTH

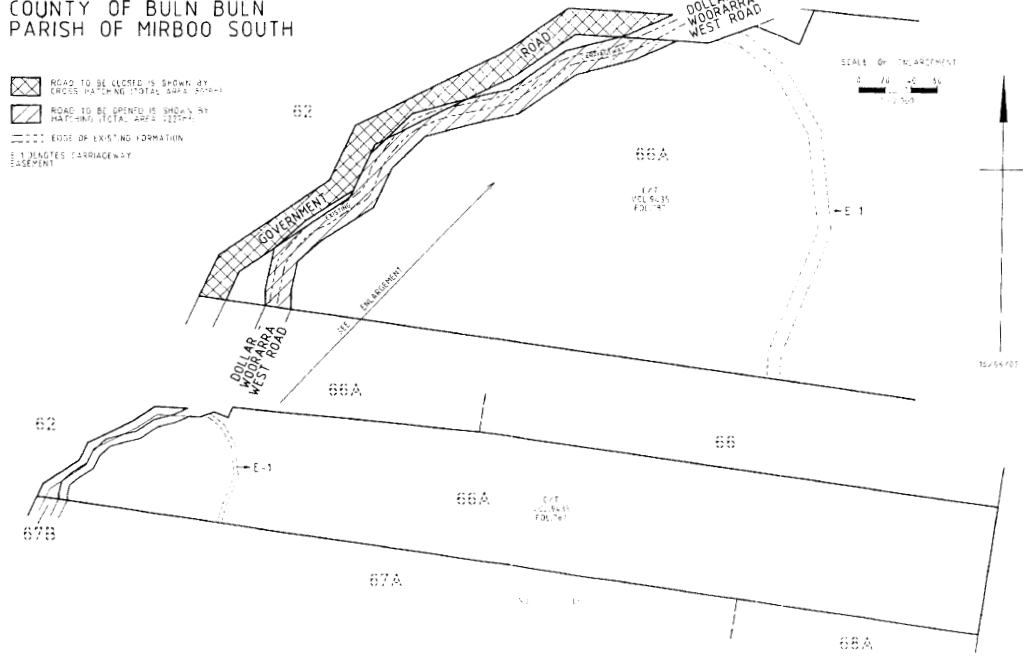

JOSEPH CULLEN
 Chief Executive

YARRA RANGES SHIRE COUNCIL

Road Discontinuance

Under Section 206 and Schedule 10, Clause 3 of the **Local Government Act 1989**, the Yarra Ranges Shire Council at its meeting held on 11 May 2004 resolved that the section of Maskell Street, Selby shown outlined in heavy lines on the plan below is not reasonably required as a road for public use and that the road be discontinued, subject to retention or any right, power or interest held by the Council, Service Authorities and Service Providers pursuant to Section 207C of the Act, and that the land from the road be retained for municipal purposes.

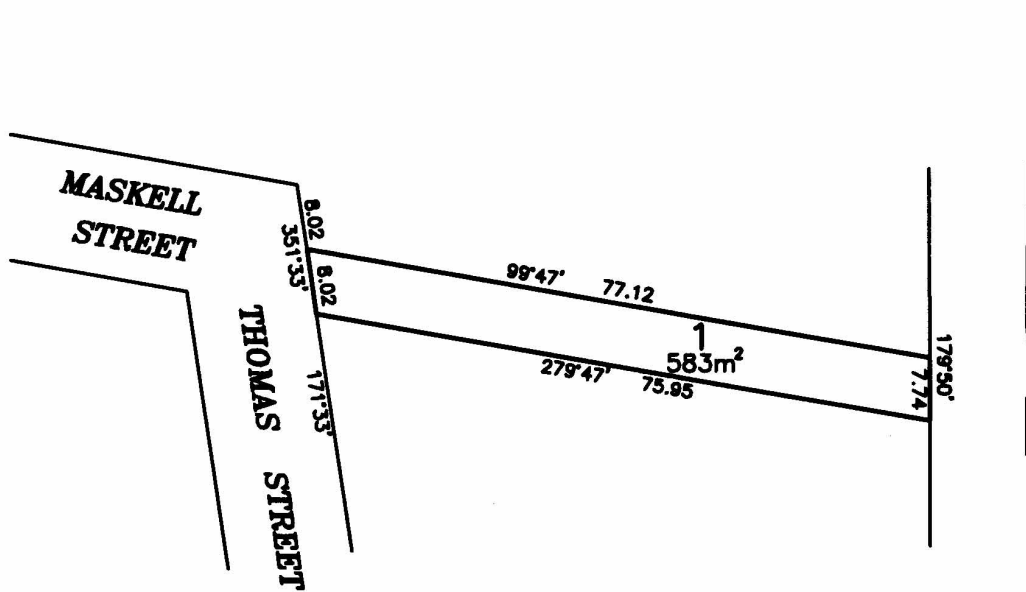

ROBERT HAUSER
Chief Executive Officer

MORELAND CITY COUNCIL

Road Discontinuance

Pursuant to Section 206 and Schedule 10, Clause 3 of the **Local Government Act 1989**, the Moreland City Council at its ordinary meeting held on 28 April 2004, formed the opinion that the road at the rear of 2 Essex Street and adjacent to 15 Bank Street, Brunswick, and shown by hatching on the plan below, is not reasonably required as a road for public use and resolved to discontinue the road and to sell the land from the road by private treaty to the abutting property owner.

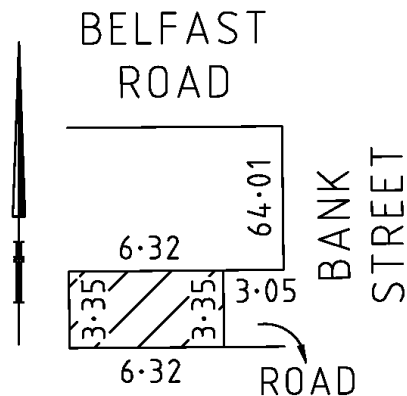

PETER BROWN
Chief Executive Officer



Planning and Environment Act 1987

CASEY PLANNING SCHEME

Notice of the Preparation of an Amendment

Amendment C73

The land affected by the Amendment is located within the Cranbourne East Development Contributions Plan, neighbourhoods A and B.

The Amendment proposes to:

Place a Public Acquisition Overlay over part of the land nominated under the Development Contributions Plan for Local Structure Plan 3 Cranbourne East as LSP3 East West Road and nominated under the Cranbourne East Development Plan as Linsell Boulevard. The Overlay provides for the future development of Linsell Boulevard as a new arterial road with a 34 metre wide road reserve and an additional 12 metre wide tree reserve directly to the north and south of it where no service roads have been provided.

Alter the Development Contributions Plan for Local Structure Plan 3, Cranbourne East 1997 to:

- Update and increase funding provision for land acquisition for the LSP3 East West Road, that is currently known as Linsell Boulevard.
- Increase land acquisition to allow for a road design consistent with Council's design objectives for the area, which requires the provision of 12m wide tree reserves where no service road is provided.
- Allow Council to regularly adjust land acquisition contributions for LSP3 East West Road, that is currently known as Linsell Boulevard, based on land valuations undertaken by an independent land valuer.
- Reduce lot density and a corresponding decrease in the estimated number of lots/households to be developed in Cranbourne East to reflect current development trends.

Alter the Development Contributions Plan for Local Structure Plan 6, Cranbourne 1997 and the Development Contributions Plan for Local Structure Plan 1, Lyndhurst 1997, to reflect the reduction in lot numbers expected within Cranbourne East and the increased land acquisition cost for LSP3 East West Road (Linsell Boulevard).

You may inspect the Amendment, any documents that support the Amendment, and the explanatory report about the Amendment, at the office of the planning authority: Casey City Council, Municipal Offices, Princes Highway, Narre Warren; Casey City Council, Customer Service Centres, Cranbourne Park Shopping Centre (opposite Post Office), Cranbourne, and Shop 8, 101 Seebeck Drive, Narre Warren South; and at Planning Information Centre, Upper Plaza, Nauru House, 80 Collins Street, Melbourne.

This can be done during office hours and is free of charge.

Any person who may be affected by the Amendment may make a submission to the planning authority. The closing date for submissions is 21 June 2004. A submission must be sent to: Manager Planning, Casey City Council, Municipal Offices, PO Box 1000, Narre Warren, 3805.

Should you have any queries about this Amendment, please contact Michelle Fleischer on 9705 5194.

Planning and Environment Act 1987

GREATER BENDIGO PLANNING SCHEME

Notice of Preparation of Amendment

Amendment C59

The City of Greater Bendigo has prepared Amendment C59 to the Greater Bendigo Planning Scheme.

The Amendment applies to land in the Township of Huntly, bounded by Burgoyne Street (on its south-western boundary), Stephensen Street (north-eastern boundary) and the Bendigo Creek (northern boundary) in the Greater Bendigo municipality.

The land affected by the Amendment is CA's 1A, 1, 2, 3, 4 and 5 Township of Huntly, Parish of Huntly.

The Amendment proposes to rezone the land from Low Density Residential (LDRZ) to Township (TZ).

You may inspect the Amendment, any documents that support the Amendment and the explanatory report about the Amendment at the following locations: at the office of the Planning Authority, City of Greater Bendigo, Planning and Building Business Unit, "The Mill", 15 Hopetoun Street, Bendigo; at the Department of Sustainability and Environment, Northern West Regional Office, corner Midland Highway & Taylor Street, Epsom; and at the Department of Sustainability and Environment, Planning Information Centre, Upper Plaza, Nauru House, 80 Collins Street, Melbourne

This can be done during office hours and is free of charge.

Any person who may be affected by the Amendment may make a submission to the planning authority.

The closing date for submissions is 21 June 2004. Submissions must be sent to: Mr John McLean, The Chief Executive Officer, City of Greater Bendigo, PO Box 733, Bendigo Vic. 3552.

Planning and Environment Act 1987

MELBOURNE PLANNING SCHEME

Notice of Amendment

Amendment C78

The City of Melbourne has prepared Melbourne Planning Scheme Amendment C78 at the request of Foresite Pty Ltd acting on behalf of the landowners.

The City of Melbourne is the planning authority for the Amendment.

Land affected by the Amendment:

The land affected by the Amendment is 2 Douglas Street and 90 Turner Street, Port Melbourne. It is situated on the southern side of Turner Street and the eastern side of Douglas Street, Port Melbourne, adjacent to the Westgate Freeway.

The Amendment proposes to rezone the land from a Public Use Zone 1 (Service and Utility) to an Industrial 1 Zone.

The Amendment is available for public inspection, free of charge, during office hours at

the following places: City of Melbourne, Development Planning Branch, 6th Floor, 200 Little Collins Street, Melbourne; and Department of Sustainability and Environment, Planning Information Centre, Upper Plaza, Nauru House, 80 Collins Street, Melbourne.

Information about the Amendment is also available on the City of Melbourne website at www.melbourne.vic.gov.au.

Any person who is affected by the Amendment may make a submission about the Amendment. Submissions must be in writing and be sent to Eloise Gucciardo, Principal Officer – Development Planning, City of Melbourne, GPO Box 1603M, Melbourne Vic. 3001.

The closing date for submissions is 21 June 2004.

ELOISE GUCCIARDO

Principal Officer – Development Planning

Planning and Environment Act 1987

MONASH PLANNING SCHEME

Notice of Amendment C44

The City of Monash has prepared Amendment C44 to the Monash Planning Scheme.

The Amendment applies to land in Monash which is subject to the existing Vegetation Protection Overlay.

The Amendment proposes to modify the criteria in the Vegetation Protection Overlay provisions and exempts specific species from protection.

The Amendment and associated documentation can be inspected free of charge, during office hours at the Department of Sustainability and Environment, Planning Information Centre, Upper Plaza, Nauru House, 80 Collins Street, Melbourne, and at the offices of the Monash City Council, 293 Springvale Road, Glen Waverley.

Submissions about the Amendment should quote Amendment C44 and be sent to the City of Monash, PO Box 1, Glen Waverley 3150 by 1 July 2004.

DAVID CONRAN

Chief Executive Officer

Planning and Environment Act 1987

MONASH PLANNING SCHEME

Notice of Amendment C54

The City of Monash has prepared Amendment C54 to the Monash Planning Scheme.

The Amendment applies to a triangular piece of land abutting the western boundary of 490 Wellington Road, Mulgrave.

The Amendment proposes to rezone the land from Road Zone 1 to Industrial 1 with Design and Development Overlay 1.

The Amendment and associated documentation can be inspected free of charge, during office hours at the Department of Sustainability and Environment, Planning Information Centre, Upper Plaza, Nauru House, 80 Collins Street, Melbourne, and at the offices of the Monash City Council, 293 Springvale Road, Glen Waverley.

Submissions about the Amendment should quote Amendment No. C54 and be sent to the City of Monash, PO Box 1, Glen Waverley 3150 by 1 July 2004.

DAVID CONRAN
Chief Executive Officer

Planning and Environment Act 1987

MONASH PLANNING SCHEME

Notice of Amendment C55

The City of Monash has prepared Amendment C55 to the Monash Planning Scheme.

The Amendment applies to residential areas in Monash.

The Amendment proposes to introduce a "Non Residential Use and Development in Residential Areas" policy with consequential changes to the Municipal Strategic Statement into the Monash Planning Scheme.

The Amendment and associated documentation can be inspected free of charge, during office hours at the Department of Sustainability and Environment, Planning Information Centre, Upper Plaza, Nauru House, 80 Collins Street, Melbourne, and at the offices of the Monash City Council, 293 Springvale Road, Glen Waverley.

Submissions about the Amendment should quote Amendment No. C55 and be sent to the City of Monash, PO Box 1, Glen Waverley 3150 by 1 July 2004.

DAVID CONRAN
Chief Executive Officer

**Planning and Environment Act 1987**MOUNT ALEXANDER
PLANNING SCHEMENotice of Preparation of an Amendment
Amendment C22

The Mount Alexander Shire Council has prepared Amendment C22 to the Mount Alexander Planning Scheme.

Land affected by the Amendment:

Lots 1, 2 and 3 LP 210919 and CA's 14B and 14G, Sect D8 Parish of Castlemaine, being land between Ireland and Martin Streets, Castlemaine.

What the Amendment does:

The Amendment rezones the subject land from Rural Living to Low Density and removes the land from the Development Plan Overlay Schedule 3.

The Amendment can be inspected at:

You may inspect the Amendment, any documents that support the Amendment and the explanatory report about the Amendment at the following locations: Mount Alexander Shire, 45 Lyttleton Street, Castlemaine; Mount Alexander Shire, 9 Halford Street, Castlemaine; Department of Sustainability and Environment, Planning Information Centre, Nauru House, 80 Collins Street, Melbourne; and Department of Sustainability and Environment, Northern Regional Office, corner Taylor Street and Midland Highway, Epsom.

The closing date for submissions is 28 June 2004.

A submission must be in writing and sent to the Chief Executive Officer, Mount Alexander Shire, PO Box 185, Castlemaine Vic. 3450.

IVAN GILBERT
Chief Executive Officer

Planning and Environment Act 1987
STRATHBOGIE PLANNING SCHEME

Notice of Amendment
Amendment C14

Strathbogie Shire Council has prepared Amendment C14 to the Strathbogie Planning Scheme.

The Amendment affects general areas throughout the municipality that have been recognised as being subject to flooding risk.

The Amendment:

- Amends boundaries of the Urban Floodway Zone in the townships of Euroa and Avenel;
- Replaces the current (Rural) Floodway Overlay and Land Subject to Inundation Overlay mapping with updated mapping for both of these overlays;
- Amends Clause 21.05-4, Environment and Heritage;
- Replaces the schedules to the Floodway Overlay and Land Subject to Inundation Overlay;
- Includes two Local Floodplain Development Plans for the Castle Creek/ Seven Creeks and Goulburn River precincts as Incorporated documents to the Strathbogie Planning Scheme.

A copy of the Amendment, supporting documents and explanatory report can be inspected, free of charge, during office hours, at: Strathbogie Shire Council, corner of Binney and Bury Streets, Euroa; Strathbogie Shire Council, corner of High and Vale Streets, Nagambie; Department of Sustainability and Environment Northeastern Region, 35 Sydney Road, Benalla; and Department of Sustainability and Environment head office, Nauru House, 80 Collins Street, Melbourne.

Any person who may be affected by the Amendment may make a submission to the planning authority. The closing date for submissions is 30 July 2004. Written submissions about the Amendment must be sent to Mr K. Hannagan, Chief Executive Officer, Strathbogie Shire Council, PO Box 177, Euroa, 3666 by 30 July 2004.

K. HANNAGAN
Chief Executive Officer

Planning and Environment Act 1987
STRATHBOGIE PLANNING SCHEME

Notice of Amendment
Amendment C17

Strathbogie Shire Council has prepared Amendment C17 to the Strathbogie Planning Scheme.

The Amendment affects general areas throughout the municipality that have been recognised as wildfire prone due to existing vegetation, land aspect and topography.

The Amendment replaces the current Wildfire Management Overlay mapping with updated mapping proposed to be designated by Strathbogie Shire Council as Bushfire Prone Areas under the **Building Act 1993**.

A copy of the Amendment, supporting documents and explanatory report can be inspected, free of charge, during office hours, at: Strathbogie Shire Council, corner of Binney and Bury Streets, Euroa; Strathbogie Shire Council, corner of High and Vale Streets, Nagambie; Department of Sustainability and Environment Northeastern Region, 35 Sydney Road, Benalla; and Department of Sustainability and Environment head office, Nauru House, 80 Collins Street, Melbourne.

Any person who may be affected by the Amendment may make a submission to the planning authority. The closing date for submissions is 30 July 2004. Written submissions about the Amendment must be sent to Mr K. Hannagan, Chief Executive Officer, Strathbogie Shire Council, PO Box 177, Euroa, 3666 by 30 July 2004.

K. HANNAGAN
Chief Executive Officer

Planning and Environment Act 1987
STRATHBOGIE PLANNING SCHEME

Notice of Amendment
Amendment C18

Strathbogie Shire Council has prepared Amendment C18 to the Strathbogie Planning Scheme.

The Amendment affects various Goulburn Valley Water sites in Avenel, Euroa, Longwood, Nagambie and Violet Town, land in Mitchell Street, Avenel and a parcel of land in McKernan Road, Balmattum.

The Amendment:

- Rezones various Goulburn Valley Water assets in Avenel, Euroa, Longwood, Nagambie and Violet Town from Rural to Public Use Zone 1 (Service and Utility);
- Removes Heritage Place HO1 from 34 Mitchell Street, Avenel, correcting the HO1 notation to apply at 26 Henry Street, Avenel;
- Applies the Heritage Overlay (HO27) to the former Balmattum blacksmith shop, McKernan Road, Balmattum.

A copy of the Amendment, supporting documents and explanatory report can be inspected, free of charge, during office hours, at: Strathbogie Shire Council, corner of Binney and Bury Streets, Euroa; Strathbogie Shire Council, corner of High and Vale Streets, Nagambie; Department of Sustainability and Environment Northeastern Region, 35 Sydney Road, Benalla; and Department of Sustainability and Environment head office, Nauru House, 80 Collins Street, Melbourne.

Any person who may be affected by the Amendment may make a submission to the planning authority. The closing date for submissions is 30 June 2004. Written submissions about the Amendment must be sent to Mr K. Hannagan, Chief Executive Officer, Strathbogie Shire Council, PO Box 177, Euroa, 3666 by 30 June 2004.

K. HANNAGAN
Chief Executive Officer

Creditors, next-of-kin and others having claims against the estate of any of the undermentioned deceased persons are required to send particulars of their claims to State Trustees Limited, ABN 68 064 593 148, 168 Exhibition Street, Melbourne, Victoria 3000, the personal representative, on or before 2 August 2004 after which date State Trustees Limited may convey or distribute the assets having regard only to the claims of which State Trustees Limited then has notice.

BOLLEN, Beryl Pearl, formerly of Flat J9, Strathalan Baptist Homes, Erskine Road, Macleod, but late of Grace Villa, 25

Grimshaw Street, Greensborough, retired and who died on 1 May 2004.

BRUCE, Jack Stanley, late of 17 Abbin Avenue, Bently East, maintenance electrician and who died on 5 February 2004.

COLEMAN, Joan Olive, formerly of Unit 1, 113 Ontario Avenue, Mildura, but late of Sunraysia Hostel For The Elderly, Calotis Street, Red Cliffs, retired and who died on 13 April 2004.

CUNNEEN, Barbara Anne, late of 41 Quinn Street, Heidelberg, Victoria, home duties and who died on 10 December 2003.

HAWTHORN, Ethel Margaret, late of 35 Harrison Street, Box Hill North, home duties and who died on 26 March 2004.

JONES, Eoin Gerard, late of Lissadell, Carrickhill Road, Upper Portmarnock County, Dublin, Ireland, retired and who died on 24 September 2003.

MATTHEWS, Alan George, late of 4 Trevor Crt, Nunawading, Victoria 3131, retired and who died on 5 March 2004.

MILSON, Betty Valerie, late of Harold McCracken House Nursing Home, 6 Church Street, Fitzroy North, pensioner and who died on 1 February 2004.

SHEIL, Victor Russell, late of Flat 3, 3 Burwood Avenue, Hawthorn East, Victoria, accountant and who died on 15 January 2004.

STERIO, Bob, also known as Bobby Sterio, late of 3/36 – 38 Kodre Street, St Albans, retired and who died on 1 May 2004.

UTTLEY, Anthony Kim, also know as Tony Uttley, late of Stratton 91 – 93 The Boulevard, Morwell and who died on 10 March 2004.

WESTON, Ronald Alexander, late of Edenvale Private Nursing Home, 188A Sterling Drive, Keilor East and who died on 27 February 2004.

Dated 17 May 2004

LAURIE TAYLOR
Estate Manager
State Trustees Limited

Department of Treasury and Finance

SALE OF CROWN LAND
BY PUBLIC AUCTION

Date of Auction: Saturday 26 June 2004 at 11.00 a.m.

Reference: 04/00583.

Crown Description: Allotment 2003, Township of Swan Hill, Parish of Castle Donnington.

Address of Property: Pritchard Street, Swan Hill.

Terms of Sale: Deposit 10%, Balance 60 days.

Area: 2621 square metres.

Officer Co-ordinating Sale: Paul Kingston, Project Manager, Victorian Government Property Group, Level 5, 1 Treasury Place, Melbourne, 3002.

Selling Agent: Noel Watson Pty Ltd, Licensed Estate Agent, 260 Campbell Street, Swan Hill, 3585.

JOHN LENDERS MP
Minister for Finance

Department of Treasury and Finance

SALE OF CROWN LAND
BY PUBLIC AUCTION

Date of Auction: Saturday 26 June 2004 at 11.00 a.m.

Reference: 04/00582.

Crown Description: Allotment 13, Section 36, Township of Swan Hill, Parish of Castle Donnington.

Address of Property: Pye Street, Swan Hill.

Terms of Sale: Deposit 10%, Balance 60 days.

Area: 1325 square metres.

Officer Co-ordinating Sale: Paul Kingston, Project Manager, Victorian Government Property Group, Level 5, 1 Treasury Place, Melbourne, 3002.

Selling Agent: Noel Watson Pty Ltd, Licensed Estate Agent, 260 Campbell Street, Swan Hill, 3585.

JOHN LENDERS MP
Minister for Finance

Department of Treasury and Finance

SALE OF CROWN LAND
BY PUBLIC AUCTION

Date of Auction: Saturday 26 June 2004 at 11.00 a.m.

Reference: 97/02696.

Crown Description: Allotment 60D, Section A, Parish of Murrabit West.

Address of Property: Murrabit Road, Murrabit.

Terms of Sale: Deposit 10%, Balance 60 days.

Area: 1.0930 hectares.

Officer Co-ordinating Sale: Paul Kingston, Project Manager, Victorian Government Property Group, Level 5, 1 Treasury Place, Melbourne, 3002.

Selling Agent: Noel Watson Pty Ltd, Licensed Estate Agent, 260 Campbell Street, Swan Hill, 3585.

JOHN LENDERS MP
Minister for Finance

Department of Treasury and Finance

SALE OF CROWN LAND
BY PUBLIC AUCTION

Date of Auction: 26 June 2004 at 11.00 a.m. on site.

Reference: 2002/01183.

Address of Property: Fraser Street, Mount Pleasant.

Crown Description: Crown Allotments 1A & 8A, Section 119, Township of Ballarat East.

Terms of Sale: Deposit 10%, Balance 60 days.

Area: 2.392 ha.

Officer Co-ordinating Sale: Garry McKenzie, Garry McKenzie & Associates Pty Ltd, 1st Floor, City Centre Arcade, 315 Sturt Street, Ballarat, Vic. 3350.

Selling Agent: Bartrop Real Estate, 50-54 Lydiard Street South, Ballarat, Vic. 3350.

JOHN LENDERS MP
Minister for Finance

Children's Services Act 1996

NOTICE OF EXEMPTION

Under Section 6 of the **Children's Services Act 1996** ("the Act"), the Minister for Community Services hereby declares that the

proprietor of the Carey Street Kindergarten, Licence No 43 ("the service") is exempt from the qualified staff members requirement as set out in regulation 24 of the Children's Services Regulations 1998.

This exemption is granted subject to the conditions that the proprietor must ensure that:

- (1) whenever children are being cared for or educated by the service the number of staff members as set out in regulation 24 are caring for or educating the children; and the staff members must include a staff member who holds a primary teaching qualification;
- (2) The nominated staff member is undertaking studies to attain a post-secondary early childhood qualification that has been approved by the Secretary to the Department of Human Services; and

Note: An early childhood qualified teacher will monitor the delivery of a preschool program.

This exemption remains in force until 31 December 2004.

Dated 28 April 2004

HON. SHERRYL GARBUTT MP
Minister for Community Services

Co-operatives Act 1996
GIPPSLAND WOOD PRODUCERS'
CO-OPERATIVE LIMITED

SALE COLLEGE CO-OPERATIVE LIMITED

Notice is hereby given in pursuance of Section 316 (1) of the **Co-operatives Act 1996** and Section 601AB(3) (e) of the **Corporations Act 2001** that, at the expiration of two months from the date hereof, the names of the aforementioned Co-operatives will, unless cause is shown to the contrary, be struck off the register and the Co-operatives will be dissolved.

Dated at Melbourne 11 May 2004

ANDREW LEVENS
Deputy Registrar of Co-operatives

Electoral Act 2002

DE-REGISTRATION OF POLITICAL PARTY

In accordance with Section 54 of the **Electoral Act 2002**, Phil Cleary – Independent Australia is hereby de-registered.

Dated 14 May 2004

C A BARRY
Electoral Commissioner

Electoral Act 2002

CHANGE TO REGISTER OF
POLITICAL PARTIES

In accordance with section 51 of the **Electoral Act 2002**, I hereby give notice of the following change to the Register of Political Parties.

Party: Australian Democrats — Victorian Division

New Address: G1 Eastbourne House,
62 Wellington Parade, East Melbourne, Victoria
3002; PO Box 135, East Melbourne, Victoria
8002.

Dated 14 May 2004

C A BARRY
Electoral Commissioner

**Drugs, Poisons and Controlled Substances
Act 1981**

SECTIONS 12G AND 12K

Notice Regarding the Amendment,
Commencement and Availability of the
Poisons Code

I, Bronwyn Pike, Minister for Health, give notice that the Poisons Code, prepared under sections 12 and 12E of the **Drugs, Poisons and Controlled Substances Act 1981**, will be amended by incorporating by reference amendments to the Commonwealth standard as prescribed by the Drugs, Poisons and Controlled Substances (Commonwealth Standard) Regulations 2001.

The Poisons Code is a document that enables certain parts of the Commonwealth standard, particularly those parts relating to the uniform scheduling, labelling and advertising of drugs and poisons, to be incorporated by reference and then applied as law in Victoria.

The Poisons Code will be amended to the extent that earlier incorporated by reference material, being the Standard for the Uniform Scheduling of Drugs and Poisons (SUSDP) No. 18, as amended by SUSDP No. 18 Amendments No.1 and 2 will be amended, varied, remade or superseded to the extent necessary by the incorporation by reference of SUSDP No. 18 Amendment No. 3.

The date fixed for the amending, varying, remaking or superseding material to take effect is 1 May 2004.

The Poisons Code may be inspected free of charge during normal business hours at the offices of the Department of Human Services situated at Level 16, 120 Spencer Street, Melbourne 3000. Contact – Duty Pharmacist, Drugs and Poisons Unit, Ph. 1300 364 545 or Level 14, 555 Collins Street, Melbourne 3000. Contact - Legislation Officer, Ph. 9616 7167. A copy of the Poisons Code may also be obtained from the Department or at www.health.vic.gov.au/dpu.

A copy of the Standard for the Uniform Scheduling of Drugs and Poisons, including amendments, may be obtained from National Mailing and Marketing Pty Ltd, PO Box 7077, CANBERRA BC, ACT 2610, ph: 02 6269 1000.

Dated 7 May 2004

HON. BRONWYN PIKE MP
Minister for Health

Mineral Resources Development Act 1990
DEPARTMENT OF PRIMARY INDUSTRIES

Exemption from Exploration Licence or
Mining Licence

I, Richard Aldous, Executive Director Minerals and Petroleum, pursuant to section 7 of the **Mineral Resources Development Act 1990** and under delegation by the Minister for Energy Industries and Resources—

1. HEREBY EXEMPT all that Crown land situated within the boundaries of exploration licence application 4817 that have been excised from the application, from being subject to an exploration licence or mining licence.
2. Subject to paragraph 3, this exemption applies until the expiration of 2 years after the grant of the licence (if the licence is granted), or until the expiration of 28 days after the application lapses or is withdrawn or refused.
3. This exemption is REVOKED in respect of any land that ceases to lie within the boundaries of the application or licence, at the expiration of 28 days after the said land ceases to lie within the boundaries of the application or licence.

Dated 17 May 2004

RICHARD ALDOUS
Executive Director
Minerals and Petroleum

Land Acquisition and Compensation Act 1986

FORM 7 S.21

Reg. 16

Notice of Acquisition

Compulsory Acquisition of Interest in Land

The Roads Corporation (VicRoads) declares that by this notice it acquires the following interest in the land described as part of Crown Allotments 32 and 33, Parish of Edgcombe comprising 12.890 hectares and being land described in Certificate of Title Volume 7390, Folio 976, shown as Parcel 130 on Survey Plan 20653.

Interest acquired: That of Robert McRae & Lorraine Elizabeth Hooppell and all other interests.

Published with the authority of VicRoads.

Dated 20 May 2004

For and on behalf of VicRoads:
BERNARD TOULET

Manager

Property Services Department

Land Acquisition and Compensation Act 1986

FORM 7 S.21

Reg. 16

Notice of Acquisition

Compulsory Acquisition of Interest in Land

The Roads Corporation (VicRoads) declares that by this notice it acquires the following interest in the land described as part of Crown Portions 35 & 36, Parish of Edgcombe, comprising 9.321 hectares and being land described in Certificate of Title Volume 5025, Folio 853, shown as Parcel 125 on Survey Plan 20652.

Interest acquired: That of Jessie Stewart & Alan Frederic Hooppell and all other interests.

Published with the authority of VicRoads.

Dated 20 May 2004

For and on behalf of VicRoads:
BERNARD TOULET

Manager

Property Services Department

Land Acquisition and Compensation Act 1986

FORM 7 S.21
Reg. 16

Notice of Acquisition

Compulsory Acquisition of Interest in Land

The Grampians Region Water Authority declares that by this notice it acquires the following interest in the land described as part of Crown Allotment 6, Parish of Ouyen, County of Mallee, comprising approx. 112,000 square metres and being land described in Certificate of Title Volume 10566, Folio 647.

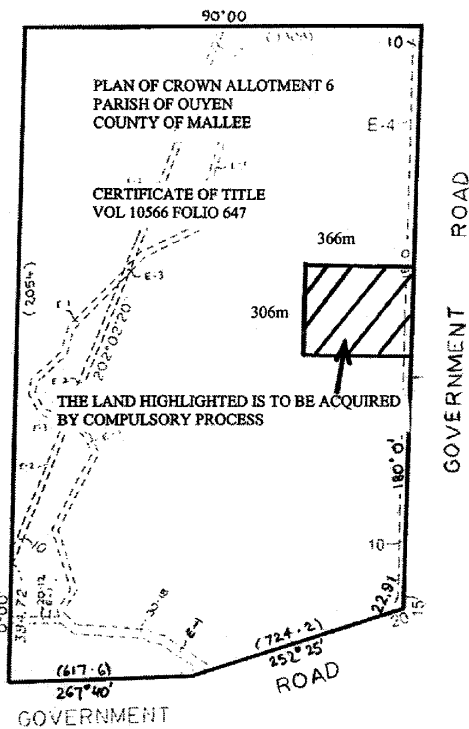

Interest Acquired: That of B.E. and C.M. O'Callaghan and all other interests.

Published with the authority of the Grampians Region Water Authority.

Dated 14 May 2004

For and on behalf of
the Grampians Region Water Authority
PETER McMANAMON
Chief Executive Officer

Road Safety Act 1986

Subordinate Legislation Act 1994

NOTICE OF INCREASE IN
DRIVER LICENCE AND
VEHICLE REGISTRATION FEES

For the purposes of section 16(3) of the **Subordinate Legislation Act 1994**, public notice is given of:

- the making of the following statutory rules under the **Road Safety Act 1986** by the Governor in Council on 18 May 2004, and
- of the purport and effect of those statutory rules.

Road Safety (Vehicles) (Registration Fees) Regulations 2004

SR No 49/2004

Effect: Among other things, these statutory rules increase the base fee for motor vehicle registration fees by 2.25% to \$160.50 in respect of registration periods commencing on or after 1 July 2004.

Road Safety (Drivers) (Fees) Regulations 2004
SR No 50/2004

Effect: Increases the fees for driver licence renewals by 2.25% in respect of periods commencing on or after 1 July 2004 to:

- \$139.00 in the case of a renewal of licence for 10 years, and
- \$41.00 in the case of a renewal of licence for 3 years.

Dated 18 May 2004

DAVID ANDERSON
Chief Executive
Roads Corporation

**Trans-Tasman Mutual Recognition
(Victoria) Act 1998**

ENDORSEMENT OF PROPOSED
REGULATIONS UNDER THE
NEW ZEALAND TRANS-TASMAN
MUTUAL RECOGNITION ACT 1997

I, Stephen Phillip Bracks, as the designated person for the State of Victoria and in accordance with section 43 of the **Trans-Tasman Mutual Recognition Act 1997** of the Commonwealth and in accordance with section 75 of the New

Zealand Trans-Tasman Mutual Recognition Act 1997 (“the New Zealand Act”), I endorse the terms of the proposed regulations set out below for the purpose of section 87(2) of the New Zealand Act.

Dated 13 May 2004

S. P. BRACKS
Premier

TRANS-TASMAN MUTUAL
RECOGNITION (REVIVAL OF
TEMPORARY EXEMPTION FOR WATER
HEATERS) REGULATIONS 2004

Governor-General

Order in Council

At Wellington this day of 2004

Present:

IN COUNCIL

Pursuant to section 87(1)(a) of the **Trans-Tasman Mutual Recognition Act 1987**, Her Excellency the Governor-General, acting on the advice and with the consent of the Executive Council, and in accordance with the recommendation of the Minister of Commerce (being satisfied as to the matters required by section 87(2) of that Act) makes the following regulations.

REGULATIONS

1. **Title**

These regulations are the Trans-Tasman Mutual Recognition (Revival of Temporary Exemption for Water Heaters) Regulations 2004.

2. **Commencement**

These regulations come into force on gazettal.

3. **Interpretation**

In these regulations, unless the context otherwise requires:

Efficiency Regulations means the Energy Efficiency (Energy Using Products) Regulations 2002

water heaters means goods in the product classes “**Low-pressure copper thermal storage electric water heaters**” or “**Storage water heaters (electrically heated)**” in Schedule 1 of the Efficiency Regulations; but does not include cylinders designed specifically for use with a solar collector or mains pressure cylinders with 3 or more heating elements.

4. **Temporary exemptions**

- (1) Regulations 4 and 5 of the Efficiency Regulations are exempted from the Act to the extent that they apply to water heaters.
- (2) The period of exemption is the period from the making of these regulations to the close of 31 January 2005.

EXPLANATORY NOTE

This note is not part of the regulations, but is intended to indicate their general effect.

These regulations, which come into force on gazettal, exempt, until the close of 31 January 2005, regulations 4 and 5 of the Energy Efficiency (Energy Using Products) Regulations 2002 from the **Trans-Tasman Mutual Recognition Act 1997** to the extent that those regulations apply to certain water heaters.

Under the Act, a product that is produced in, or imported into, Australia and that can be sold in Australia may also be sold in New Zealand, even though it may not comply with a more stringent New Zealand standard or other requirement for that product. From 1 February 2003 (when the relevant New Zealand standards came into force), Australia’s minimum energy performance standards for electric storage water heaters have been less stringent than the New Zealand standards set out in the Energy Efficiency (Energy Using Products) Regulations 2002. This potentially jeopardises the New Zealand Government’s energy efficiency objectives, with potential adverse effects on the environment. Therefore, a temporary 12-month exemption in relation to water heaters was granted under the Trans-Tasman Mutual Recognition (Temporary Exemption) Regulation 2003, with the result that all water heaters sold in New Zealand must meet the New Zealand standards set out in the Energy Efficiency (Energy Using Products) Regulations 2002.

The effect of these regulations is that for a period from the making of these regulations until the close of 31 January 2005, the exemption is revived so that the water heaters to which these regulations apply, whether capable of being sold in Australia or not, must comply with regulations 4 and 5 of the Energy Efficiency (Energy Using Products) Regulations 2002.

**Victorian Managed Insurance Authority
Act 1996**

VICTORIAN TOURISM OPERATORS
ASSOCIATION – EXTENSION OF THE
PUBLIC LIABILITY INSURANCE SCHEME

Pursuant to section 25A of the **Victorian Managed Insurance Authority Act 1996**, I direct you to provide insurance to the following adventure tourism operators:

- Adventure Guides Australia, Training Innovations;
- Bindaree Outdoor Education Services Pty Ltd;
- Grampians Bushwalking Company;
- Halls Outdoor Education & Stringy Bark Lodge;
- South West Adventures;
- The Outdoor Education Group;
- The Victorian Climbing Centre;
- Unlimited Learning Adventures; and
- Wild Side Outdoors.

The insurance should continue the existing terms and conditions (other than the premium which VMIA will determine), and will expire on 30 June 2004.

JOHN LENDERS MP
Minister for Finance

Water Act 1989

I, John Thwaites, Minister for Water, make the following Order:

MID LODDON
WATER SUPPLY PROTECTION AREA
DECLARATION ORDER 2003

1. This Order is called the Mid Loddon Water Supply Protection Area Declaration Order 2003.
2. This Order is made under the powers conferred by Division 3 of Part 3 of the **Water Act 1989** and all other available powers.
3. This Order takes effect on and from the date it is published in the Government Gazette.
4. On and from the date on which this Order takes effect—
 - (a) the area of land within the hatched border on Plan No. LEGL./03-095

and shown to be all depths, is declared to be a Water Supply Protection Area for the protection of the groundwater resources; and

- (b) the area shown shall be known as the Mid Loddon Water Supply Protection Area.

5. Plan No. LEGL./03-095 referred to in clause 4 may be inspected at the Central Plan Office, Land Registry, Department of Sustainability and Environment, 570 Bourke Street, Melbourne during business hours.

Dated 9 September 2003

JOHN THWAITES
Minister administering
the **Water Act 1989**

Private Agents Act 1966

NOTICE OF RECEIPT OF APPLICATIONS
FOR LICENCES
UNDER THE PROVISIONS OF THE
PRIVATE AGENTS ACT 1966

I, the undersigned, being the Registrar of the Magistrates' Court at Melbourne hereby give notice that applications, as under, have been lodged for hearing by the said Court on the date specified.

Any person desiring to object to any of such applications must:—

- (a) lodge with me a notice in the prescribed form of his objection and of the grounds thereof;
- (b) cause a copy of such notice to be served personally or by post upon the applicant at least three days before the hearing of the application; and
- (c) send or deliver
 - (i) where the objection is not made by the officer in charge of the police district in which the Court is situated — a copy of the notice to such officer; and
 - (ii) where the objection is not made by the Registrar or Deputy Registrar — a copy to the Registrar.

<i>Full name of Applicant or in the case of a Firm or Corporation, of the Nominee</i>	<i>Place of Abode of Applicant or Nominee</i>	<i>Name of Firm or Corporation</i>	<i>Address for Registration</i>	<i>Type of Licence</i>
Amy Louise Macarthur	109 Best Street Nth Fitzroy Vic.	Receivables Management Ltd	363 King Street, Melbourne 3000.	Commercial Sub-Agents Licence
Sayuri Phillipa Piper	1 Stortford Ave Ivanhoe Vic.	Receivables Management Ltd	363 King Street, Melbourne 3000.	Commercial Sub-Agents Licence
Catherine Jacinthajothy	11/51 Cardigan Street, Carlton Vic.	Receivables Management Ltd	363 King Street, Melbourne 3000.	Commercial Sub-Agents Licence
Peter James Tilley	21 First Ave, Strathmore Vic.	Receivables Management Ltd	363 King Street, Melbourne 3000.	Commercial Sub-Agents Licence

Dated at Melbourne 11 May 2004

GRAEME J. HORSBURGH
Principal Registrar
Magistrates' Court of Victoria

VICTORIA

Public Records Act 1973

SUB-SECTION 14(1)

WHEREAS, in accordance with the provisions of sub-section of the **Public Records Act 1978**, the Minister for Victorian Communities may appoint a place outside the Public Record Office Victoria as a place of deposit for any specified class of public records.

I, John Thwaites, Minister for Victorian Communities, hereby appoint the places specified in Schedule One to be places of deposit for public records, subject to the conditions set out in Schedule Two. This appointment applies for a period of ten (10) years, unless revoked sooner, from date gazetted.

SCHEDULE ONE

Ararat Genealogical Society Inc	Ararat Library, Barkly St, Ararat
Ballan Shire Historical Society Inc	Court House, 42 Stieglitz St, Ballan
Daylesford and District Historical Society Inc	100 Vincent St, Daylesford
Eaglehawk Heritage Society Inc	Court House, Sailors Gully Rd, Eaglehawk
Essendon Historical Society Inc	768 Mt Alexander Rd, Moonee Ponds
Huntly and Districts Historical Society Inc	Former Shire Office & Court House, Midland Highway, Huntly
Lake Bolac and District Historical Society Inc	Scotts Church, Montgomery St, Lake Bolac

Landsborough and District Historical Group Inc	McKinlay St, Landsborough
Malmsbury Historical Society Inc	Mechanics Institute, Mollison St, Malmsbury
Trentham Historical Society	5 Camp St, Trentham
Woody Yaloak Historical Society Inc	Brooke St, Smythesdale
Woodend and District Heritage Society Inc	Court House, Forest St, Woodend

SCHEDULE TWO

That—

descriptions of the records to be transferred are submitted to the Public Record Office for approval prior to transfer;

the records are transferred with the agreement of the Keeper of Public Records;

the records transferred to a community place of deposit are not considered by the Keeper of Public Records to be part of the permanent archives of the State;

there is no charge for the inspection of the public records;

the Keeper of Public Records has the right to inspect the facility at any time in accordance with section 13A of the **Public Records Act 1973**.

Dated 13 April 2004

JOHN THWAITES MP
Minister for Victorian Communities

Transport Act 1983

TOW TRUCK DIRECTORATE
OF VICTORIA

Tow Truck Application

Notice is hereby given that the following application will be considered by the Licensing Authority after 23 June 2004.

Notice of any objection to the granting of an application should be forwarded to reach the Director, Tow Truck Directorate of Victoria, Level 6, 14–20 Blackwood Street, North Melbourne (PO Box 666, North Melbourne 3051) not later than 17 June 2004.

It will not be necessary for interested parties to appear on the date specified, unless advised in writing.

Tooles Motors Pty Ltd. Application for variation of conditions of tow truck licence number TOW275 which authorises the licensed vehicle to be managed, controlled and operated from a depot situated at 32 Hovel Street, Wodonga to change the depot address to 12 Reid Street, Wodonga.

Note: This Licence is under consideration for transfer to Grealy Motors Pty Ltd.

Dated 20 May 2004

STEVE STANKO
Director

Transport Act 1983
ROAD DECLARATIONS
AND DEDICATIONS

ROAD DECLARATIONS AND DEDICATIONS –

The Roads Corporation pursuant to the **Transport Act 1983**, upon publication of this notice declares, varies or rescinds the declaration of the roads or parts of the roads, as described below and on the plans attached, and further declares that the roads or parts of the roads which are declared by this notice are fit to be used as a public highway and are now absolutely dedicated to the public for use as a public highway within the meaning of any law now or hereafter in force.

STATE HIGHWAY

- a) Those parts of the Princes Highway identified by hatching on the plans numbered GP 20093–99, GP 20099A, GP 20100, GP 20100A, GP 20101–21, GP 20232, GP 20233, GP 20235, GP 20248–50 and GP 20252 are declared as described in the legend on the said plans.

ROAD

- b) Those parts of Fernbank-Glenaladale Road, East Boundary Track, Road and Mittons Lane identified by hatching on the plans numbered GP 20099B, GP 20099C, GP 20100B, GP 20101A and GP 20251 are declared as described in the legend on the said plans.

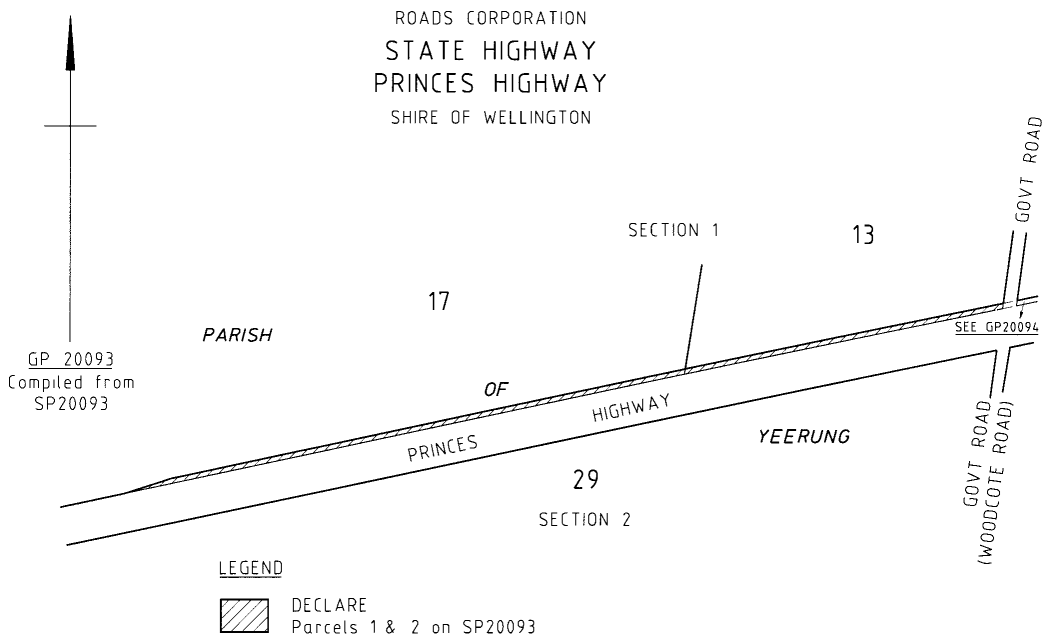

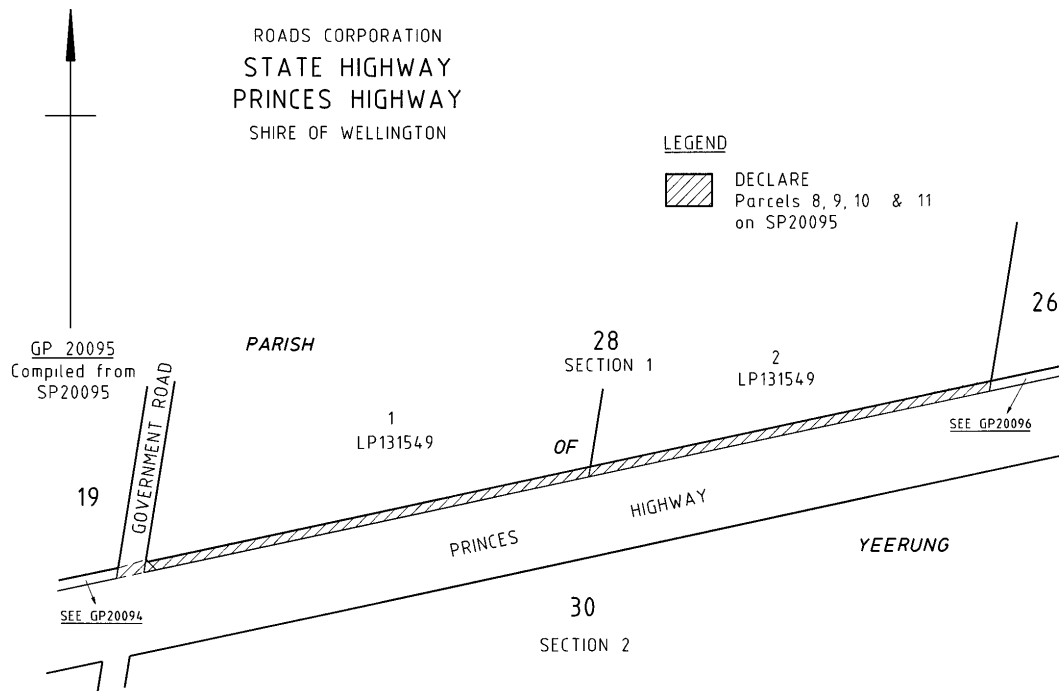
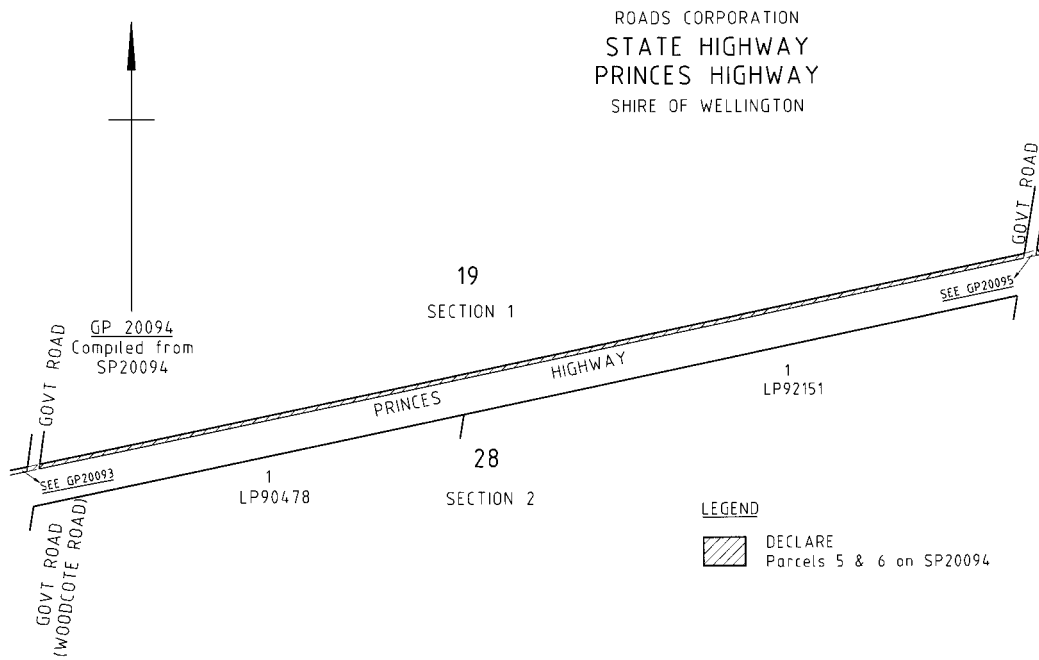

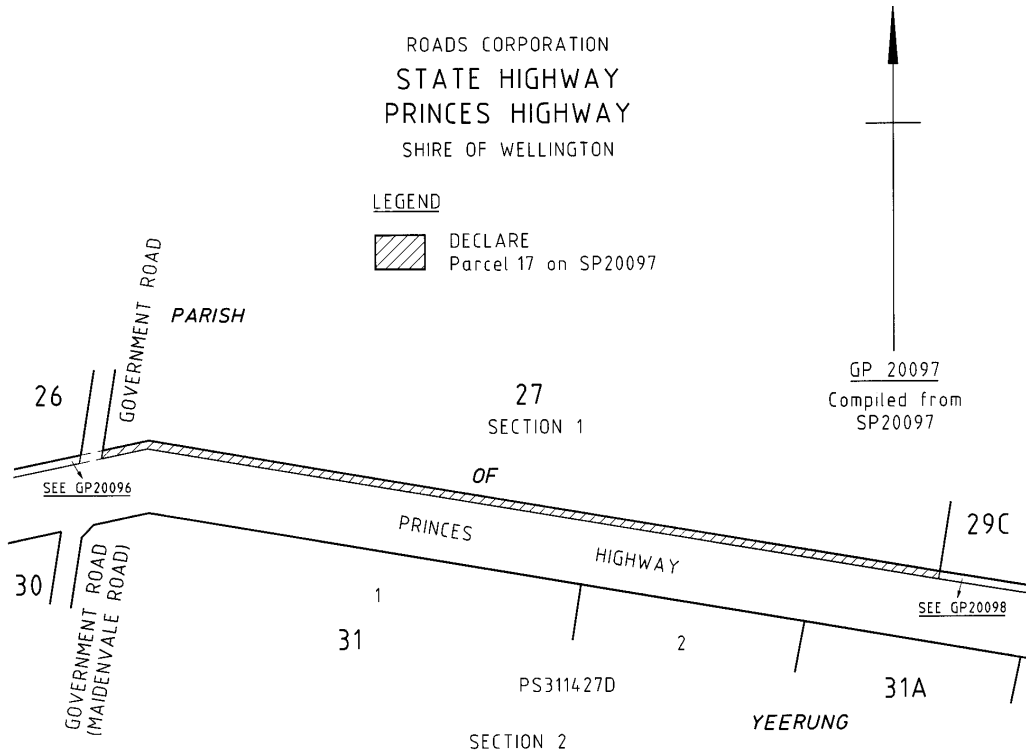
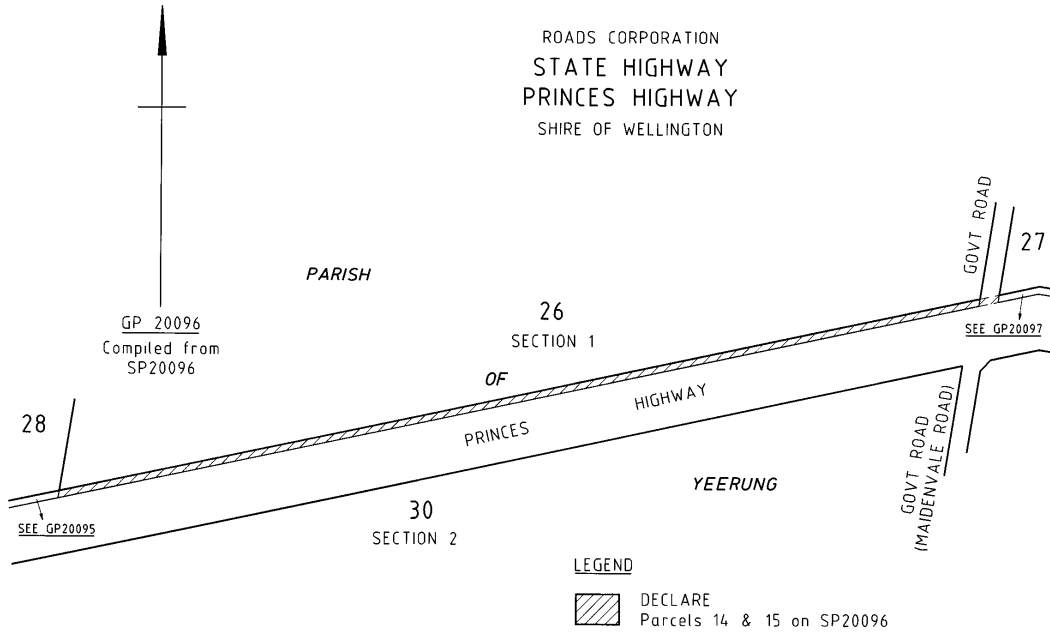

ROADS CORPORATION
STATE HIGHWAY
PRINCES HIGHWAY
SHIRE OF WELLINGTON

LEGEND

 DECLARE
Parcel 19 on SP20098A

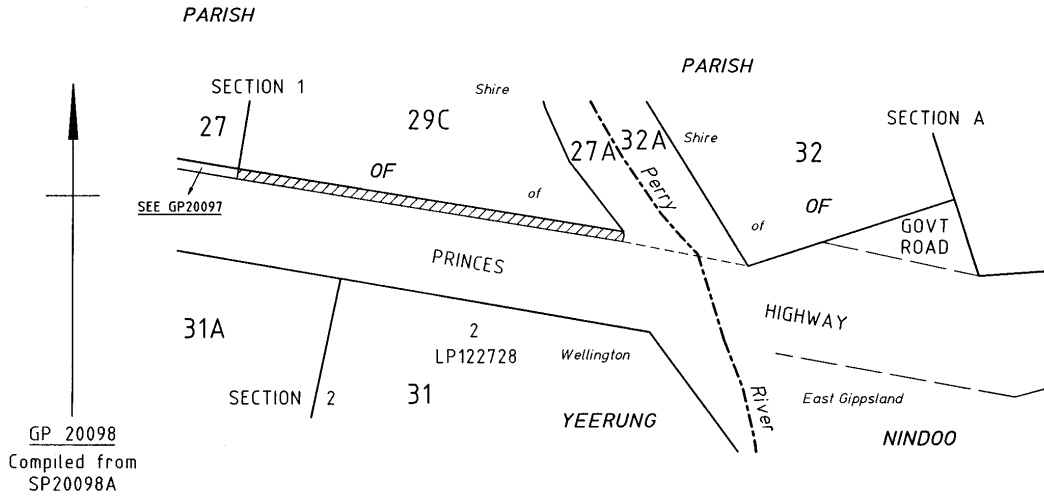

ROADS CORPORATION
STATE HIGHWAY
PRINCES HIGHWAY
SHIRE OF EAST GIPPSLAND

LEGEND

 DECLARE
Parcels 100, 102, 103,
104 & 111 on SP20099A

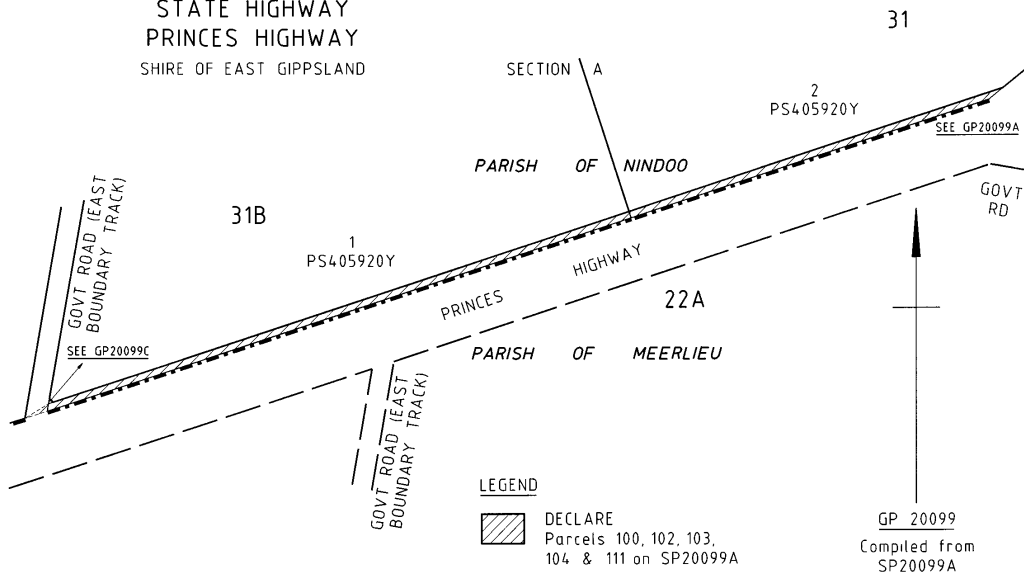

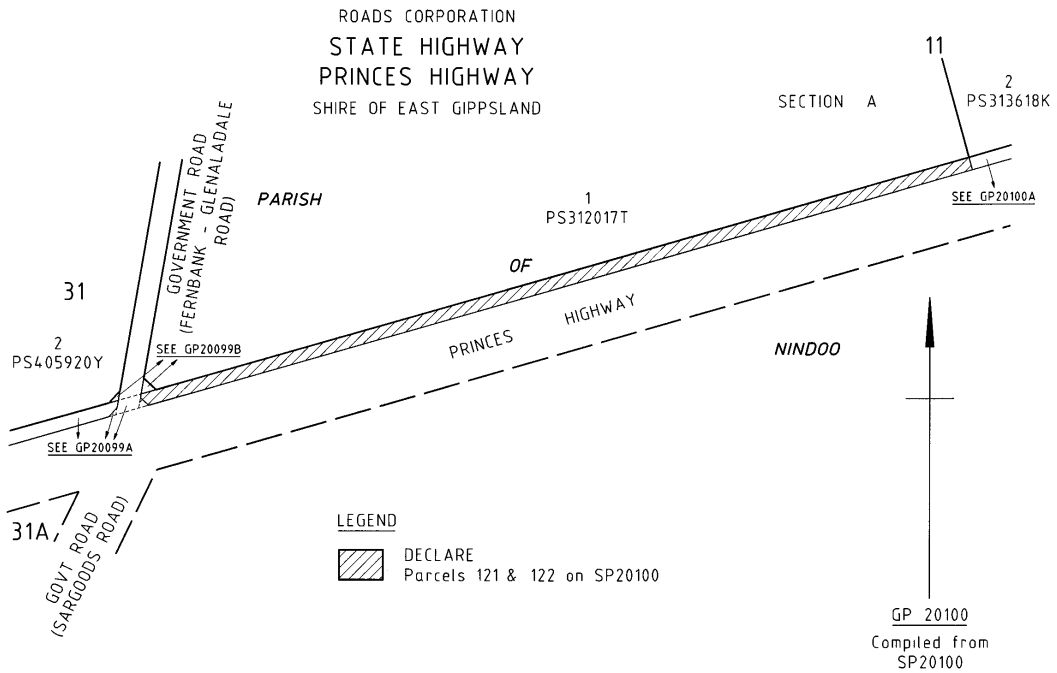
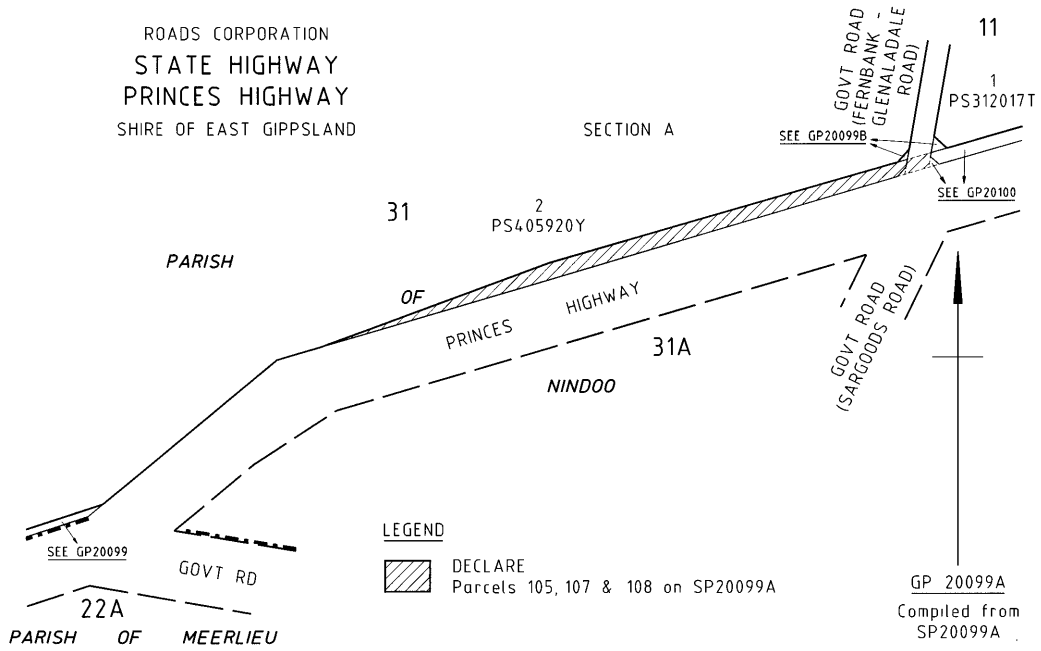

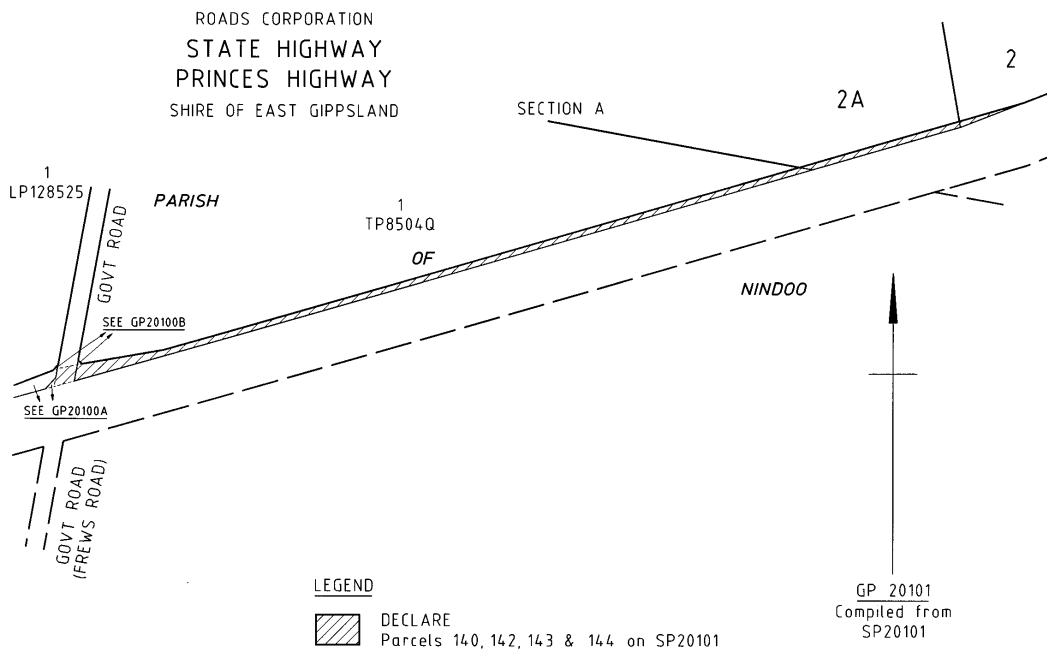
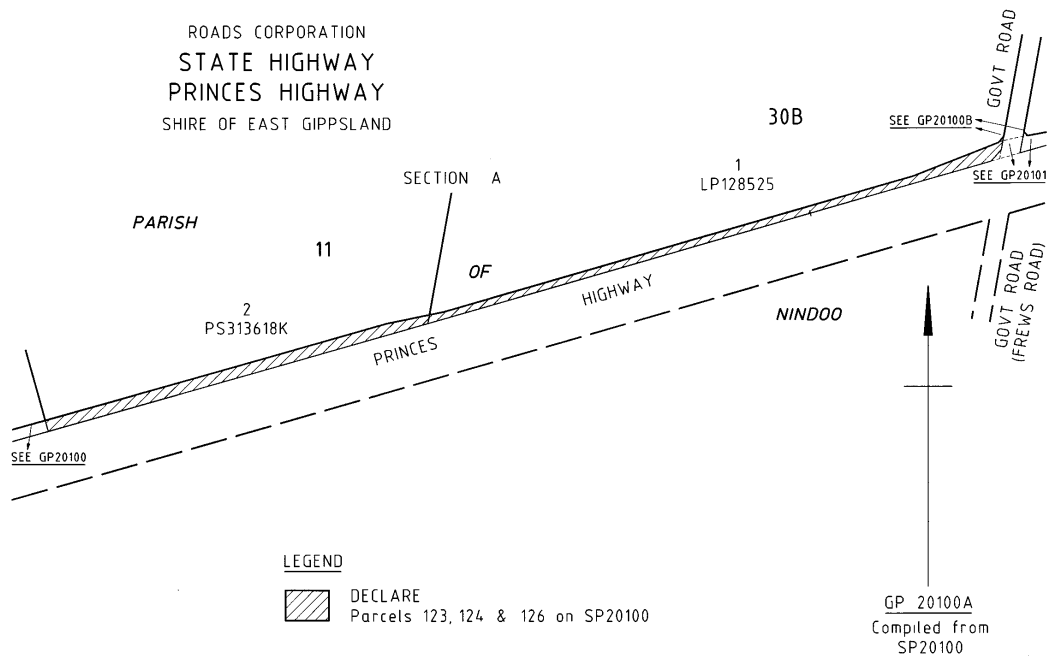

ROADS CORPORATION
STATE HIGHWAY
PRINCES HIGHWAY
SHIRE OF EAST GIPPSLAND

LEGEND

 DECLARE
Parcels 145, 151 on SP20101 &
201, 202, 204 & 207 on SP20102

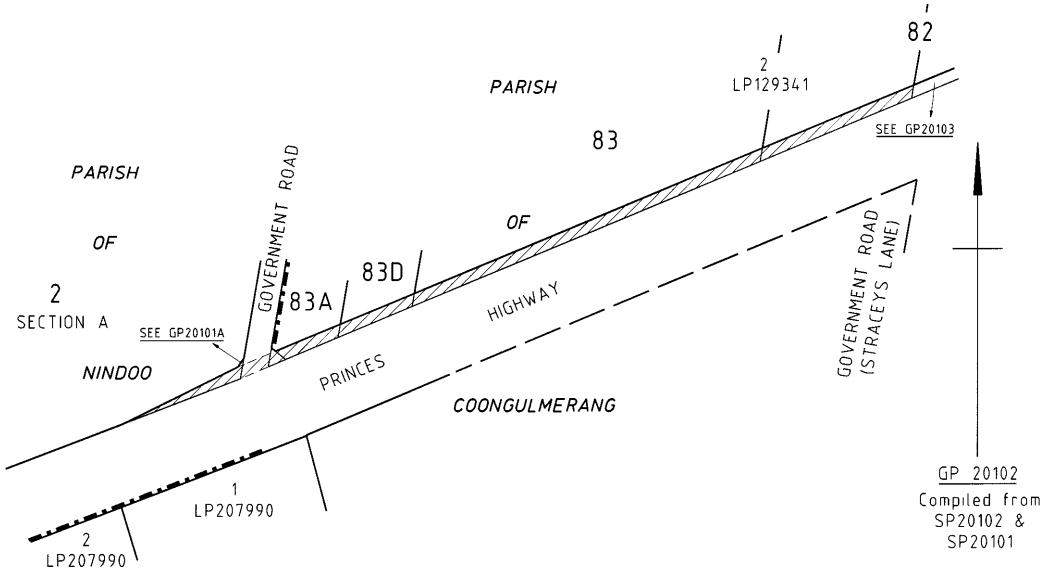

ROADS CORPORATION
STATE HIGHWAY
PRINCES HIGHWAY
SHIRE OF EAST GIPPSLAND

LEGEND

 DECLARE
Parcel 208 on SP20103

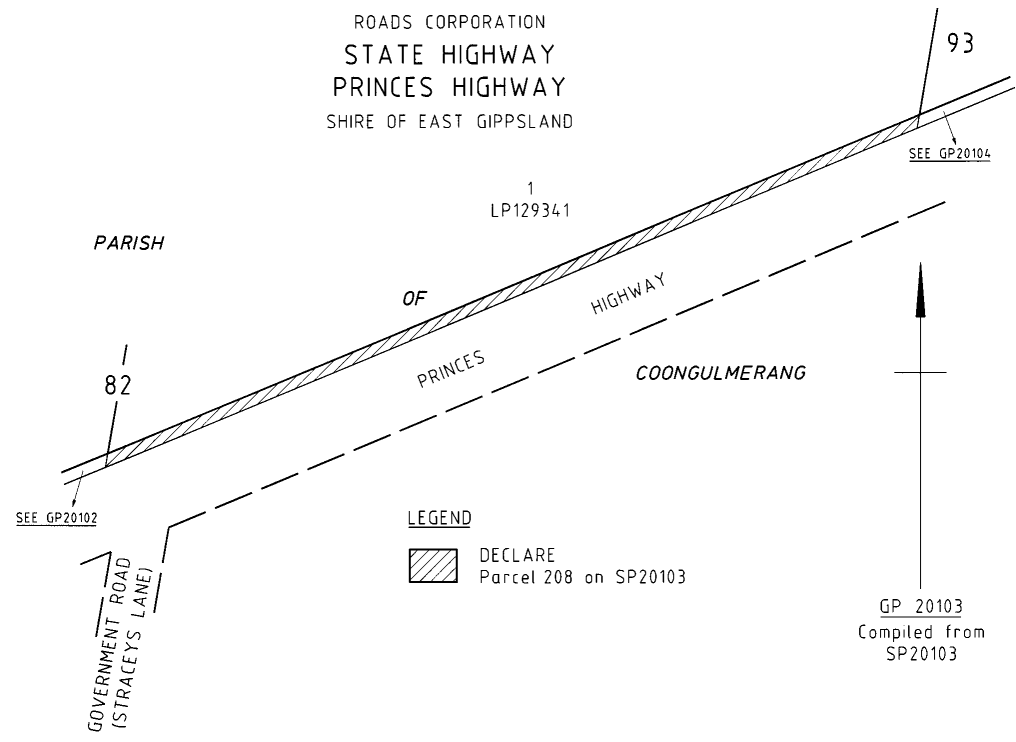

ROADS CORPORATION
STATE HIGHWAY
PRINCES HIGHWAY
SHIRE OF EAST GIPPSLAND

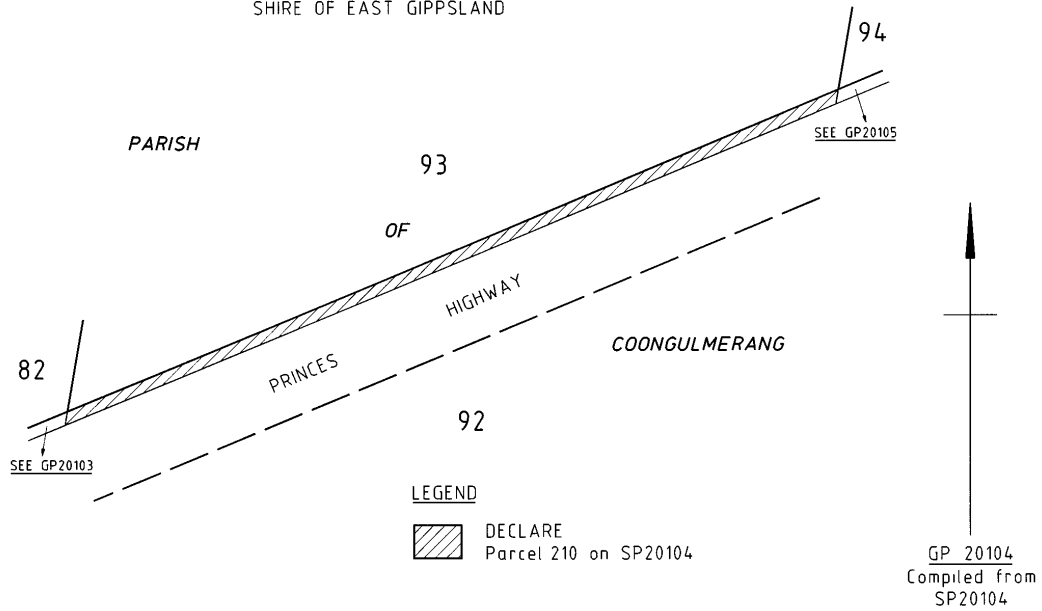

ROADS CORPORATION
STATE HIGHWAY
PRINCES HIGHWAY
SHIRE OF EAST GIPPSLAND

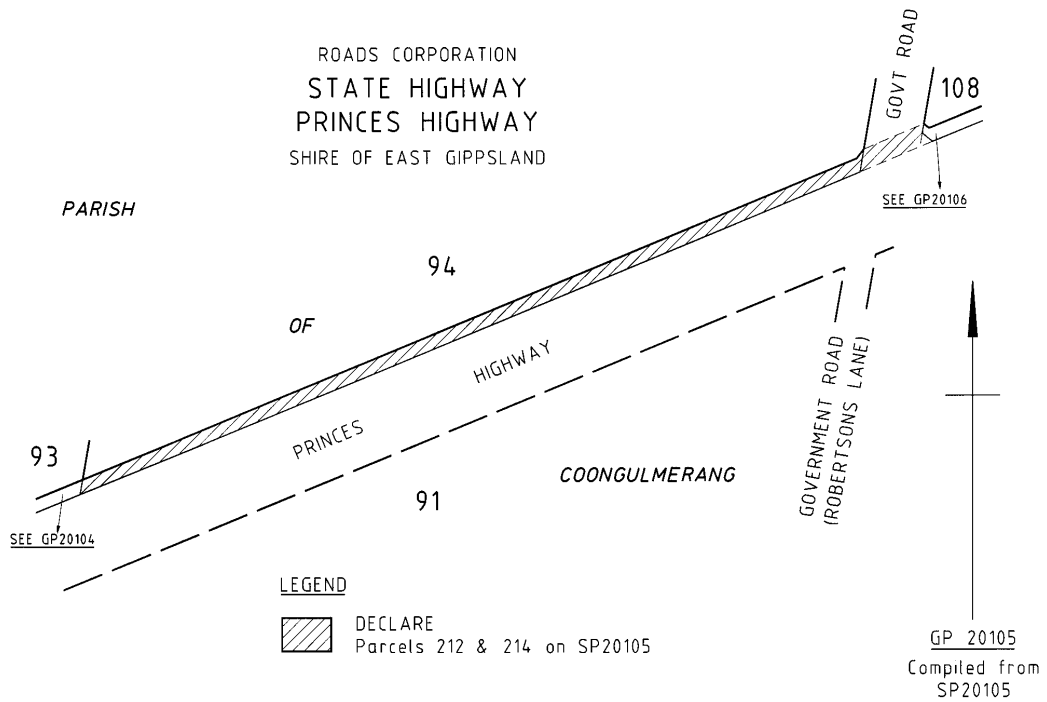

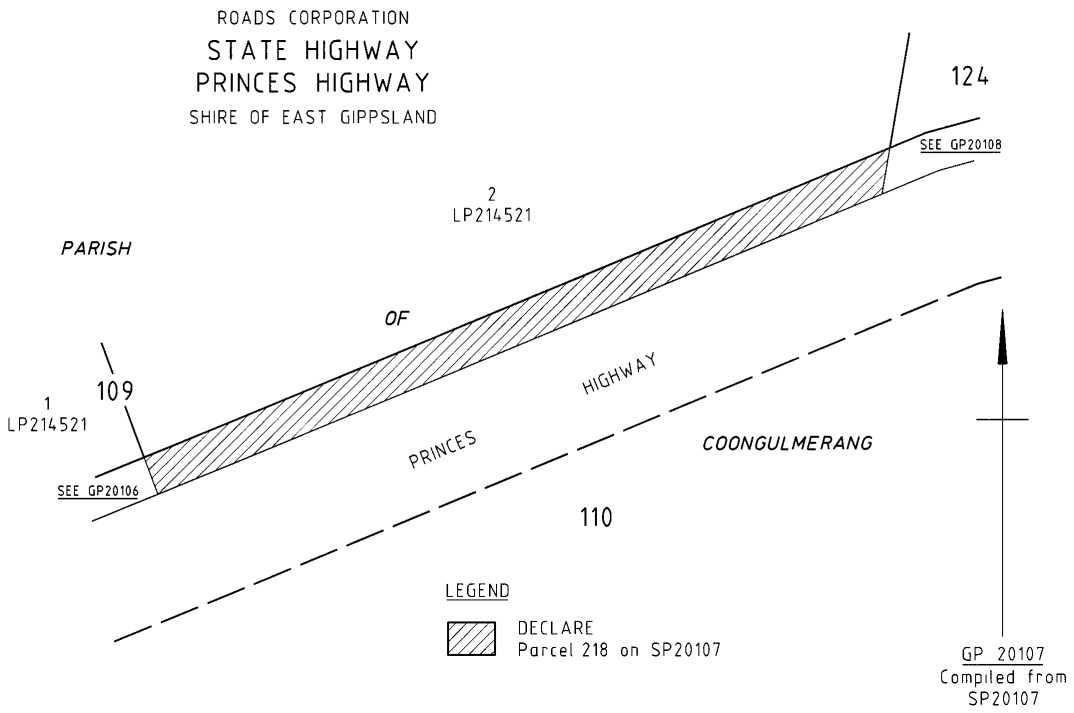
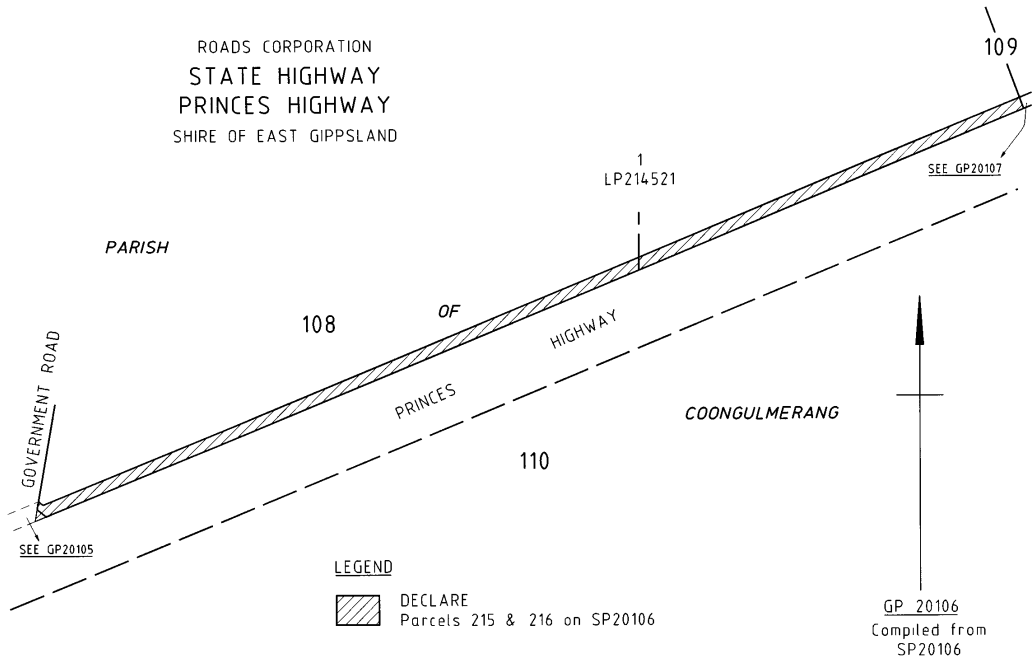

ROADS CORPORATION
STATE HIGHWAY
PRINCES HIGHWAY
SHIRE OF EAST GIPPSLAND

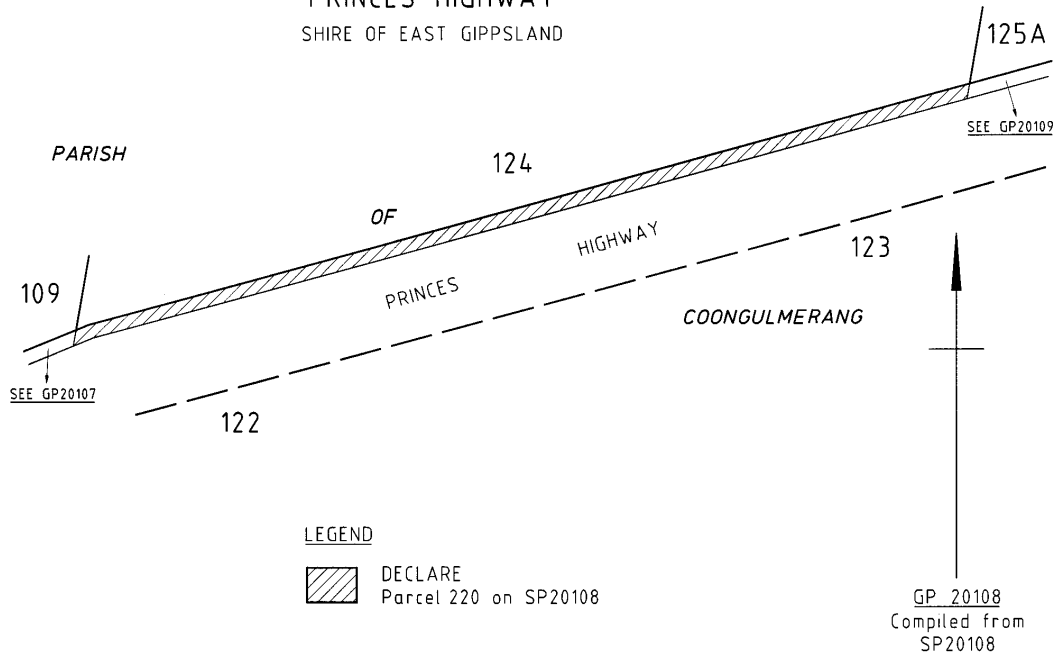

ROADS CORPORATION
STATE HIGHWAY
PRINCES HIGHWAY
SHIRE OF EAST GIPPSLAND

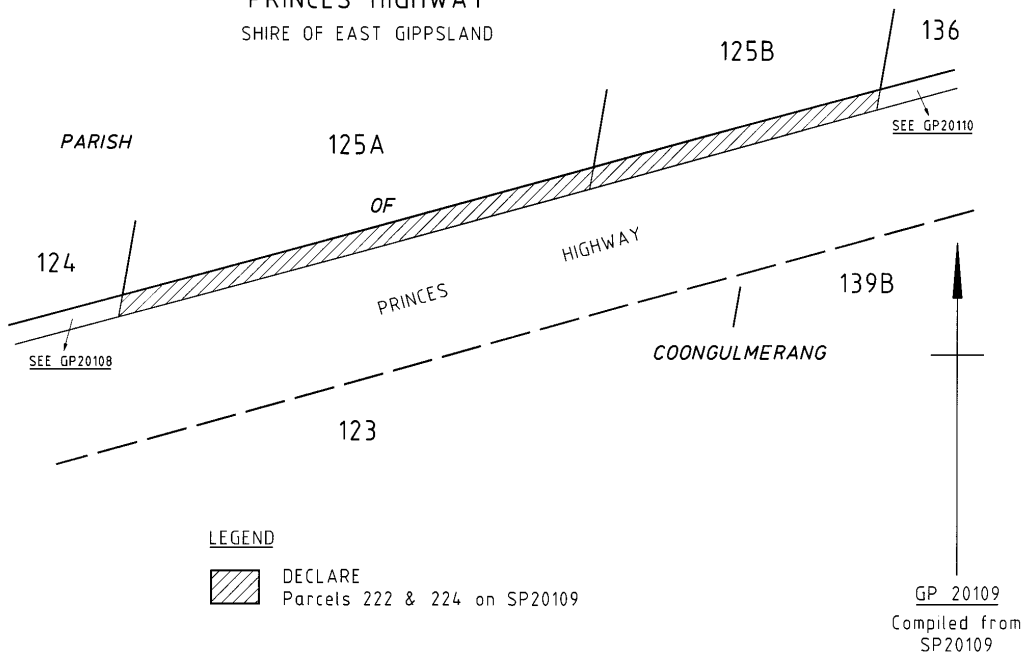

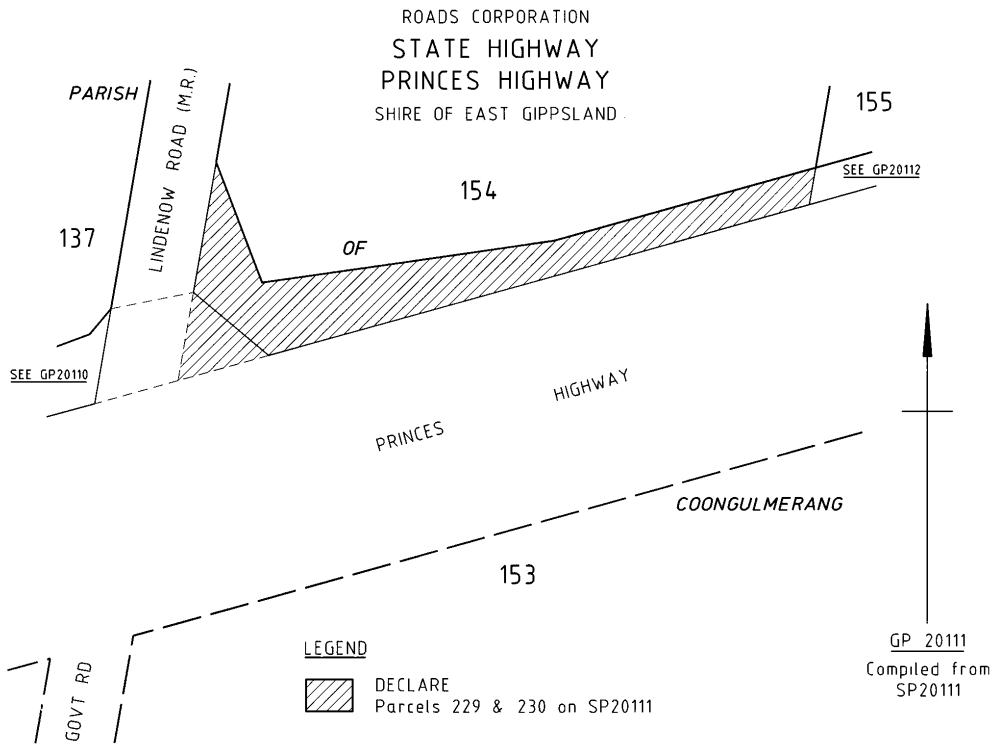
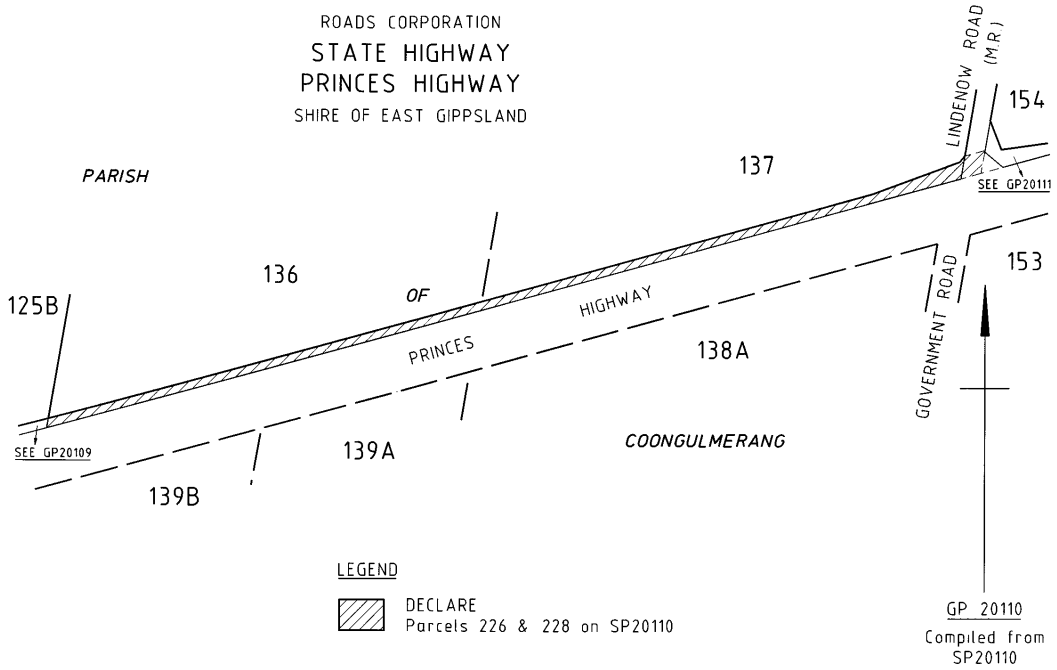

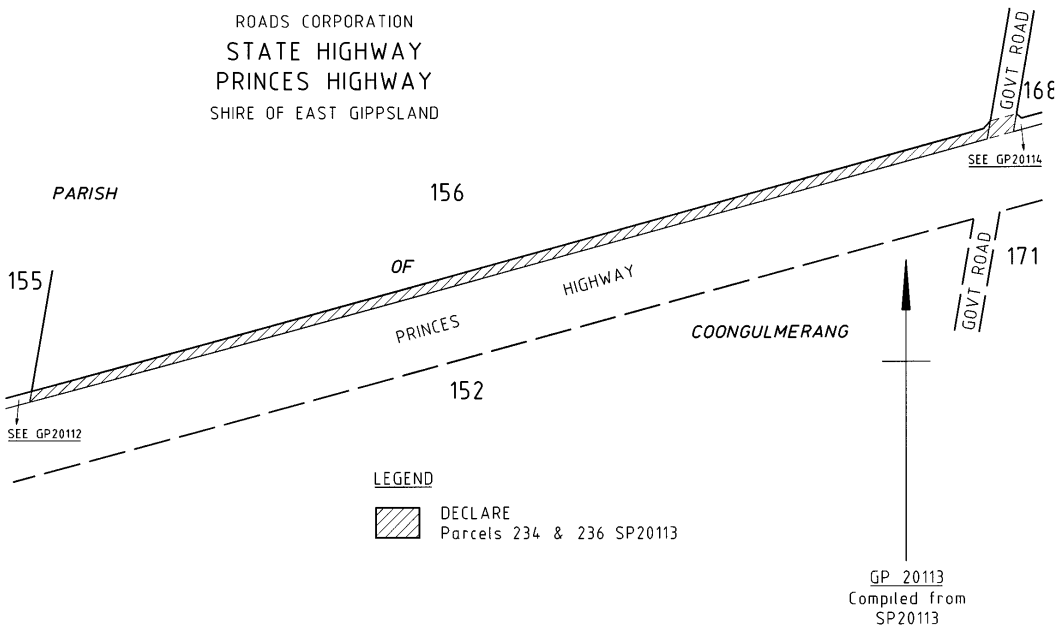
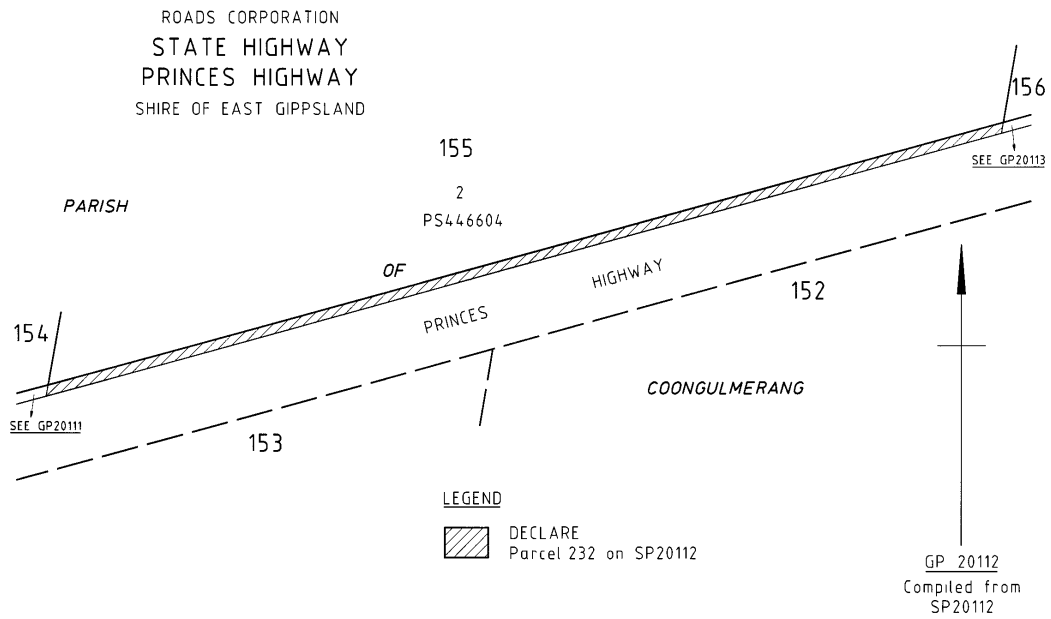

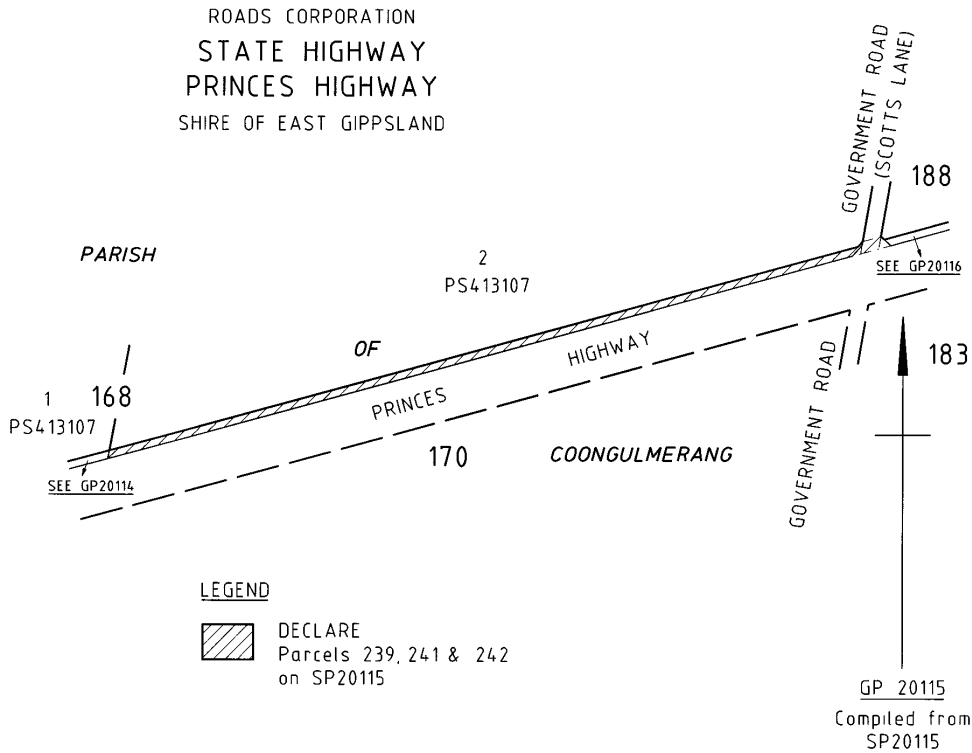
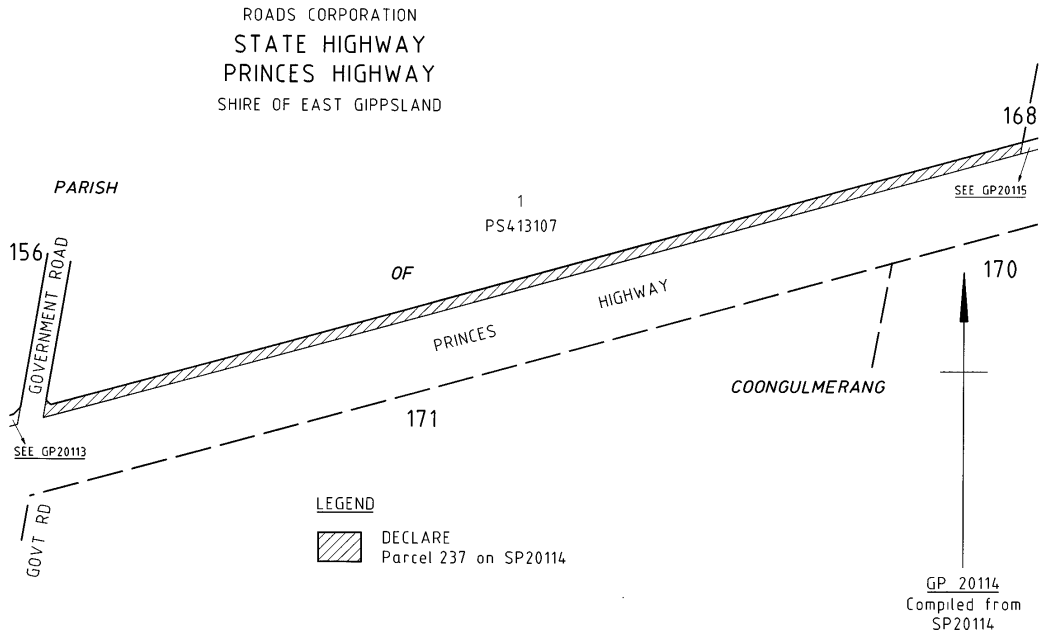

ROADS CORPORATION
STATE HIGHWAY
PRINCES HIGHWAY
SHIRE OF EAST GIPPSLAND

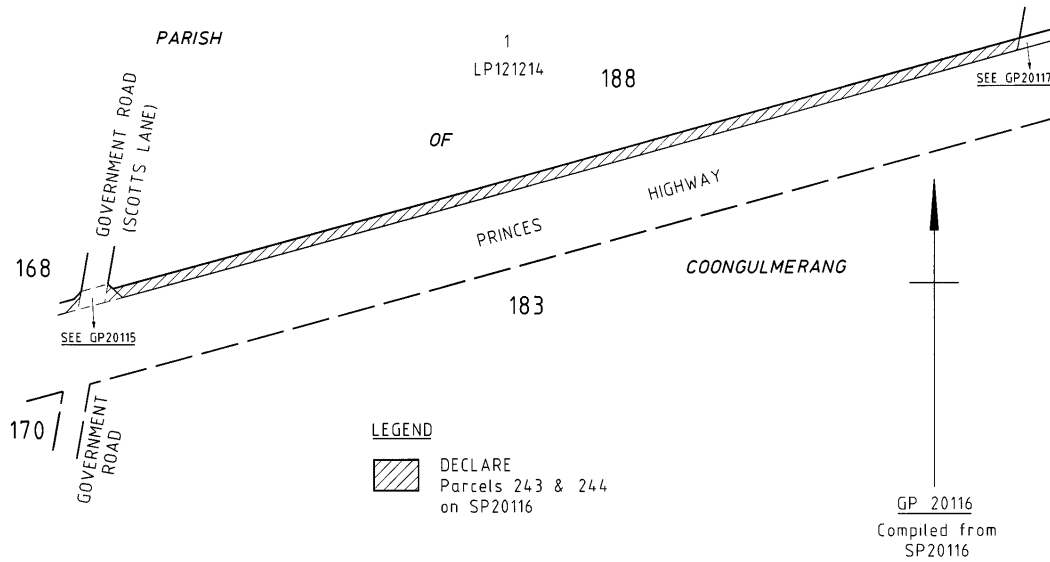

ROADS CORPORATION
STATE HIGHWAY
PRINCES HIGHWAY
SHIRE OF EAST GIPPSLAND

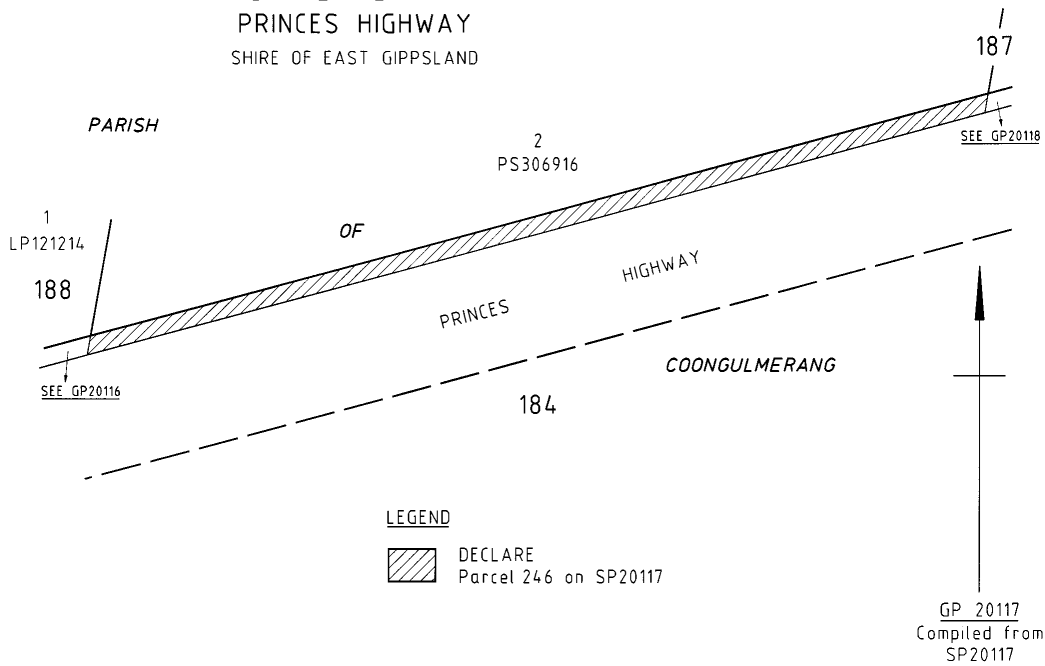

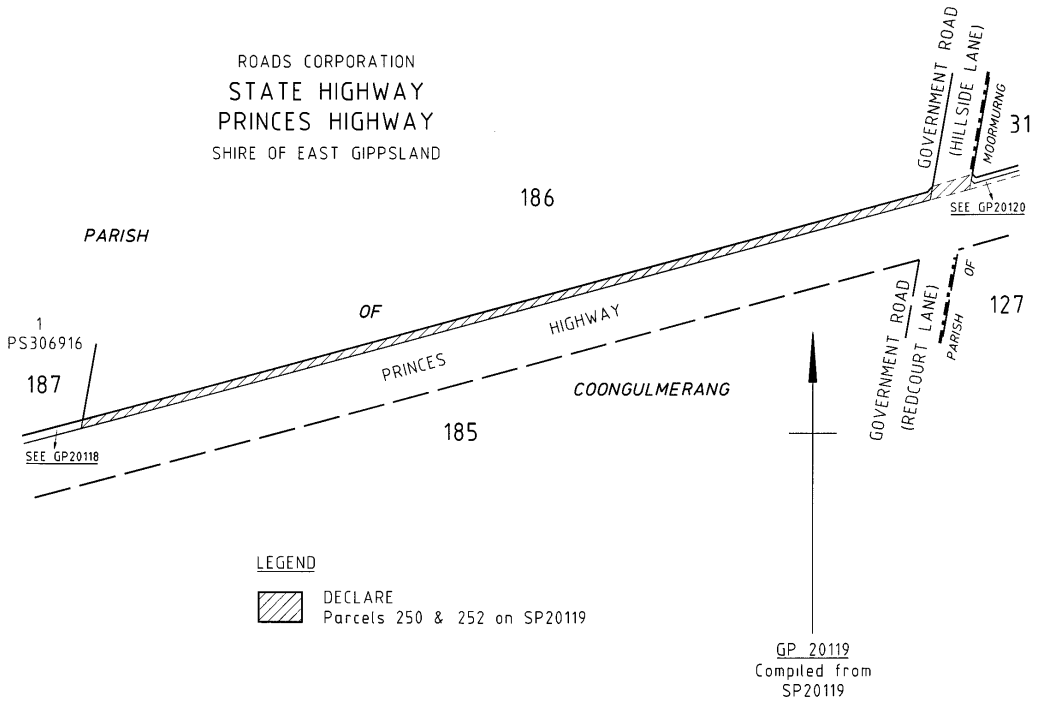
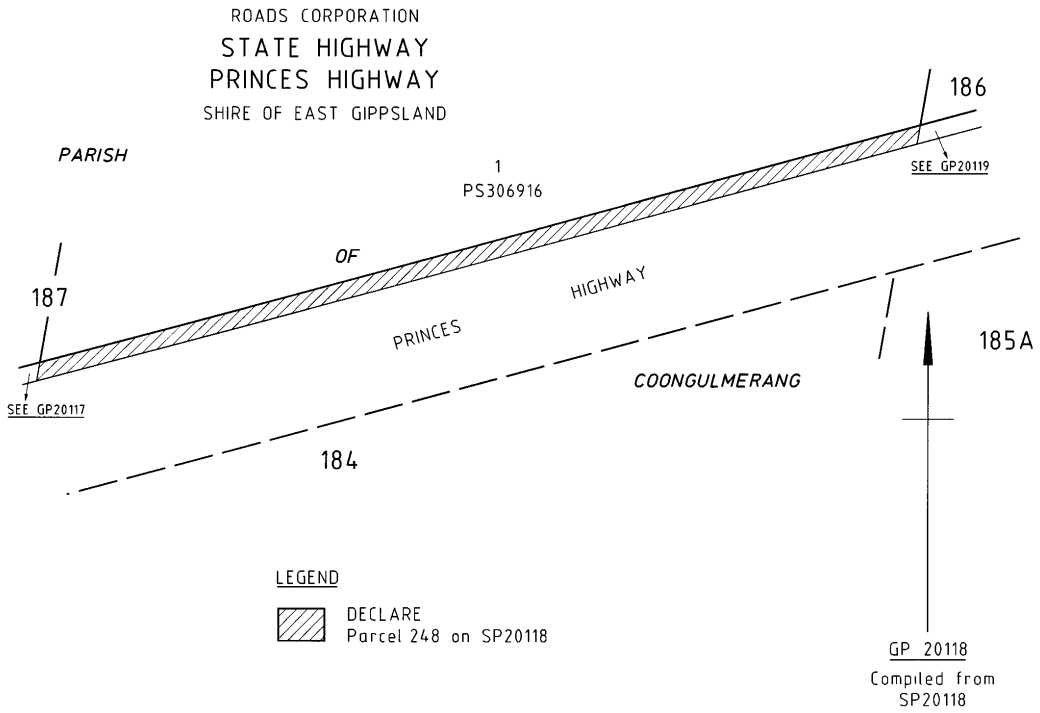

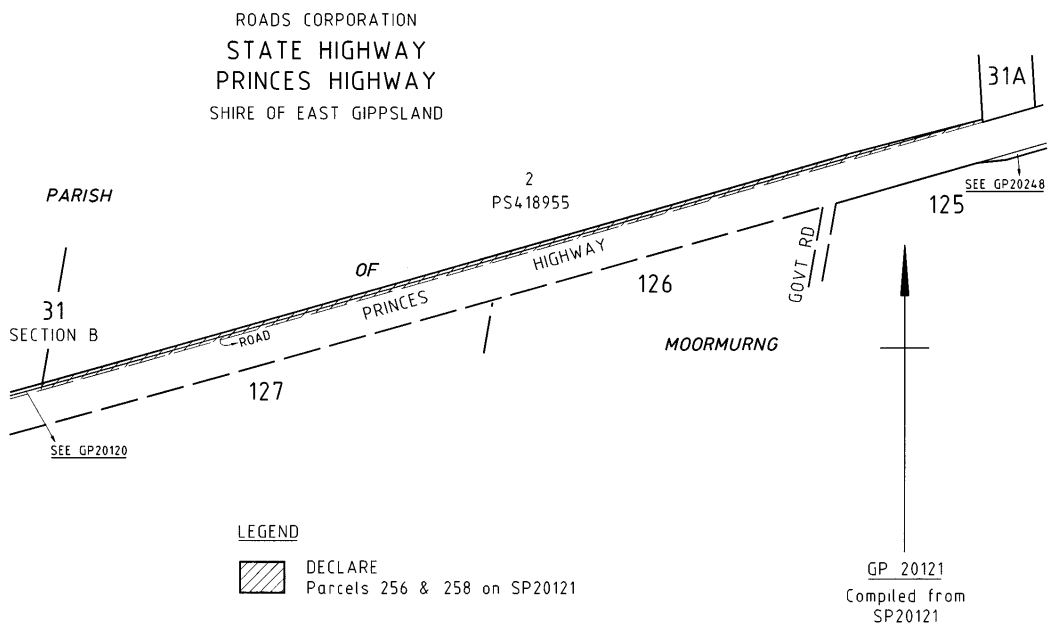
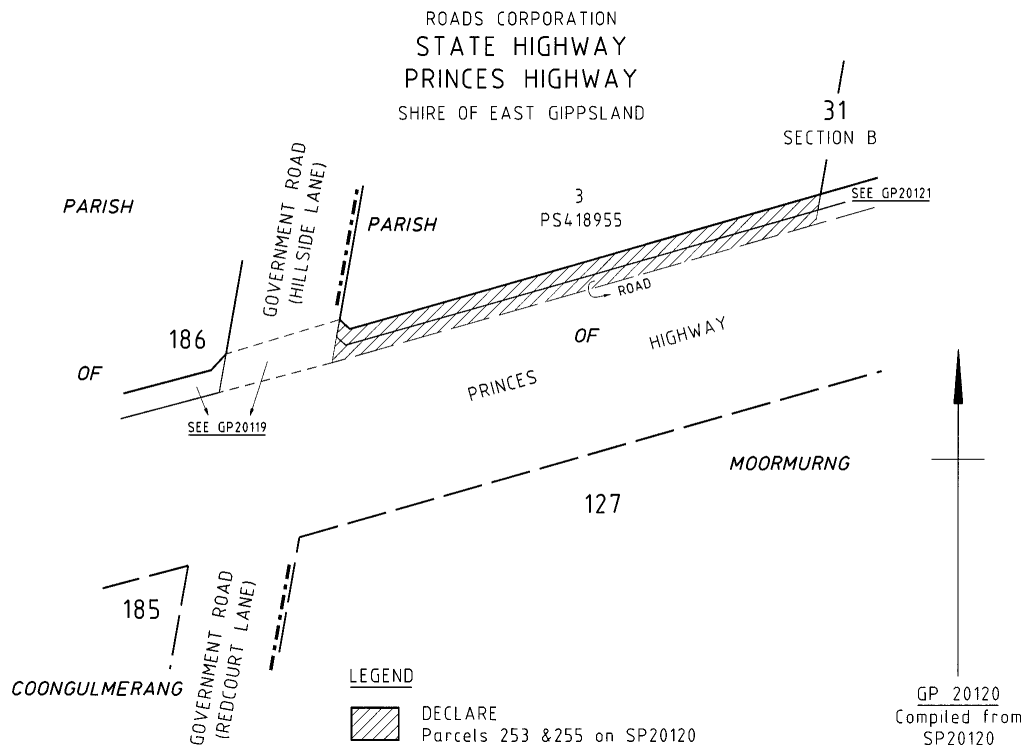

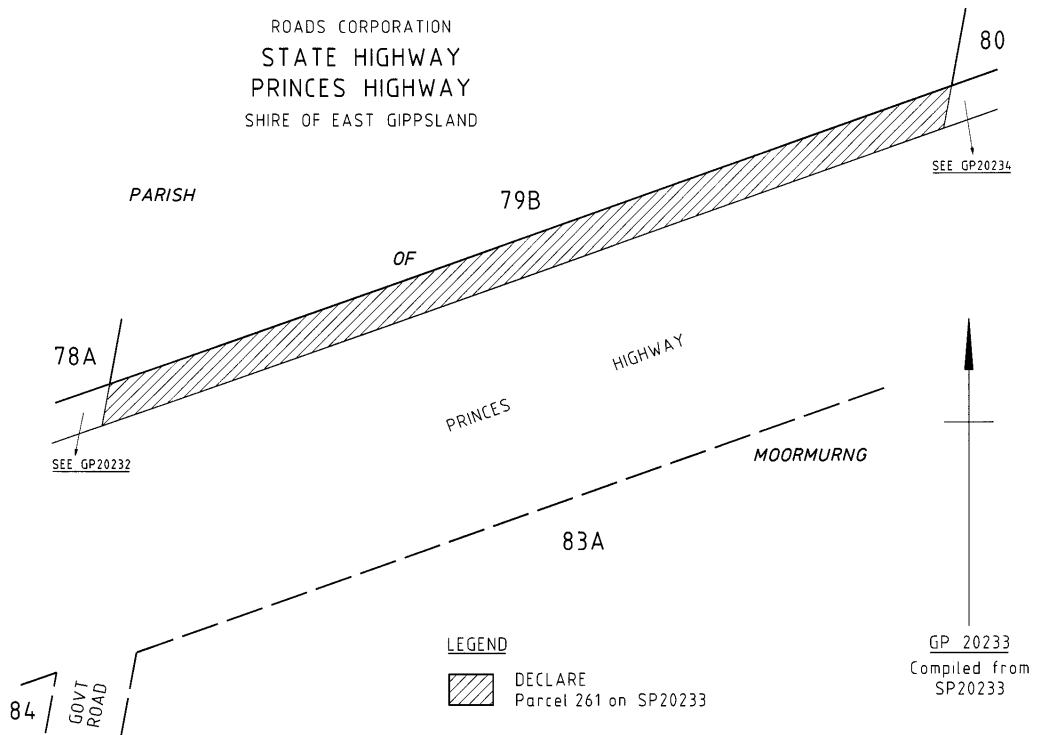
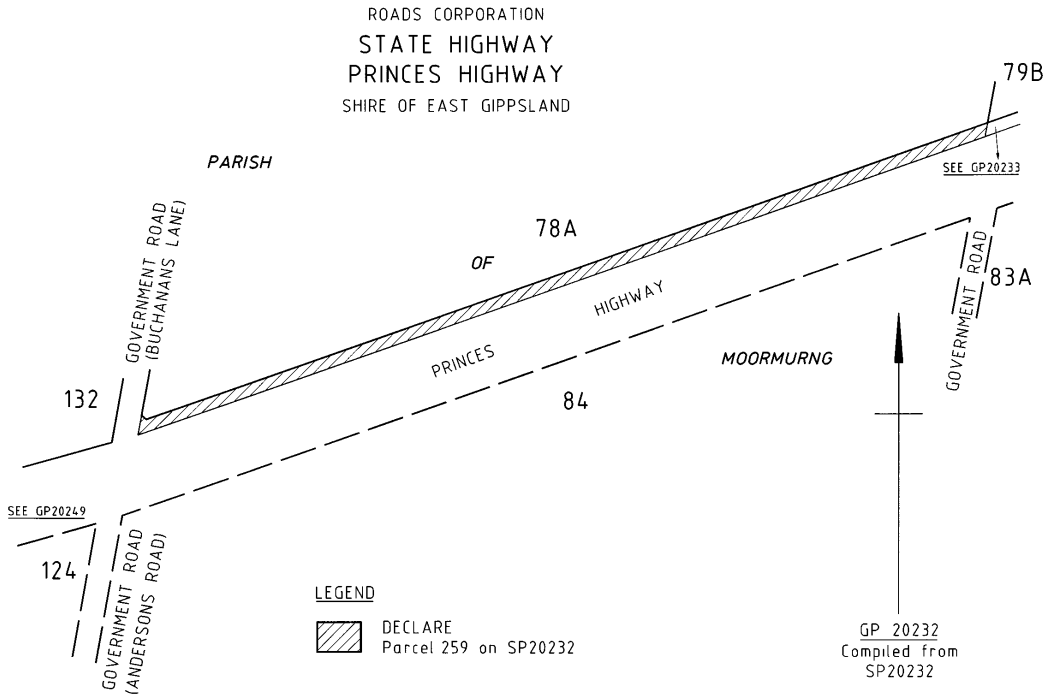

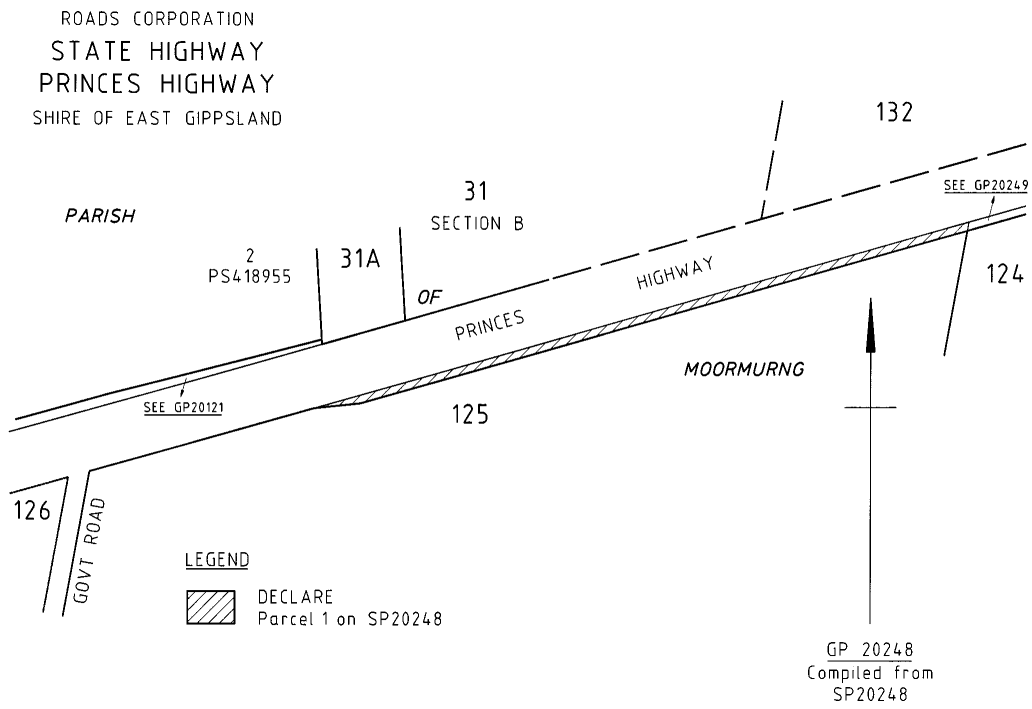
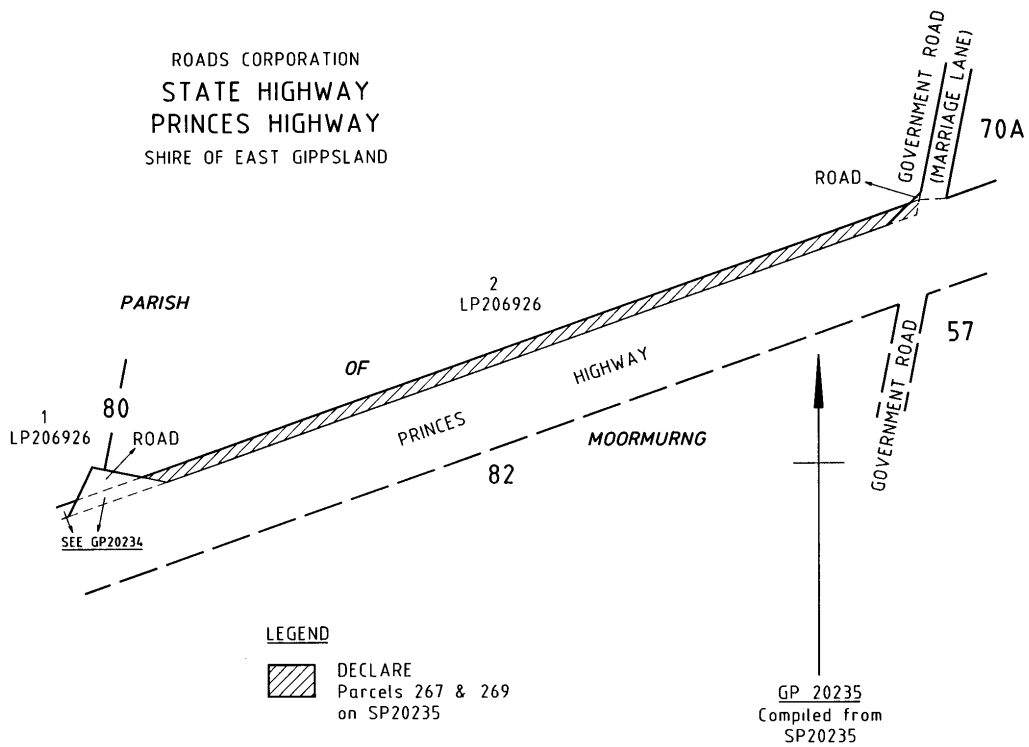



ROADS CORPORATION
STATE HIGHWAY
PRINCES HIGHWAY
SHIRE OF EAST GIPPSLAND

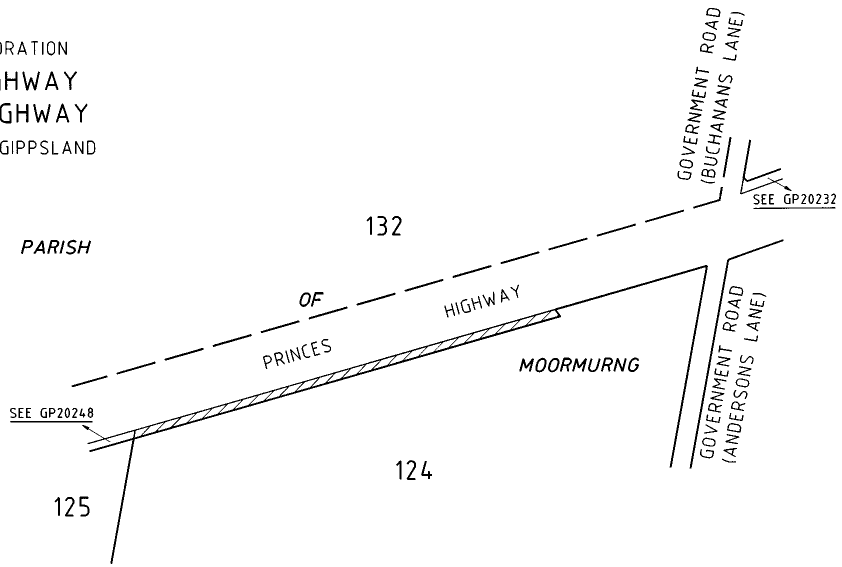

GP 20249
Compiled from
SP20249



LEGEND

 DECLARE
Parcel 3 on SP20249

ROADS CORPORATION
STATE HIGHWAY
PRINCES HIGHWAY
SHIRE OF EAST GIPPSLAND



GP 20250
Compiled from
SP20250A

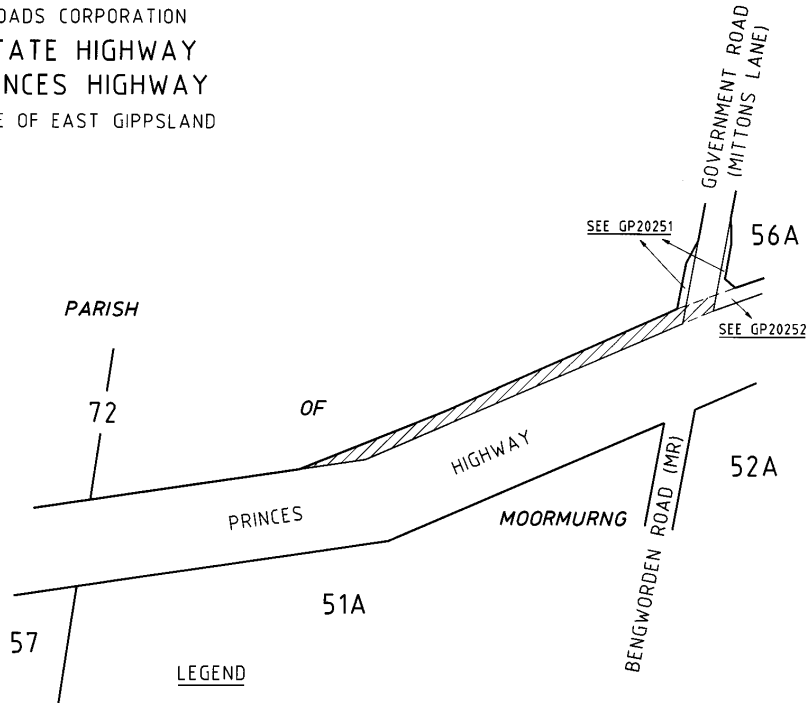

LEGEND

 DECLARE
Parcels 1A & 3 on SP20250A

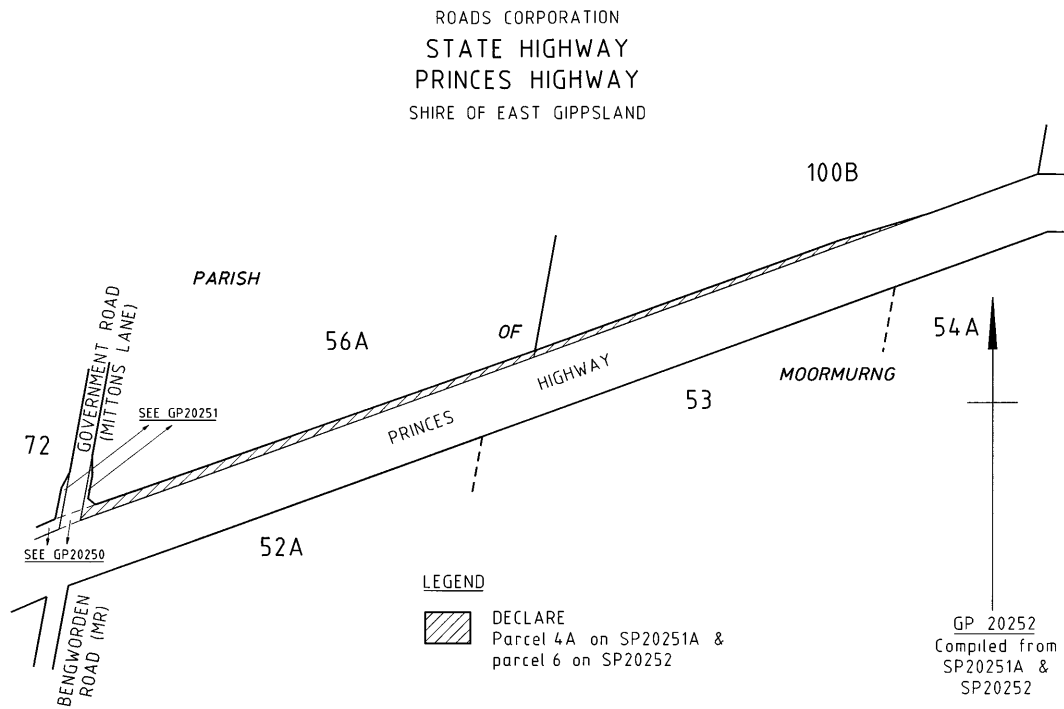

ROADS CORPORATION
FERNBANK-GLENALADALE ROAD
SHIRE OF EAST GIPPSLAND

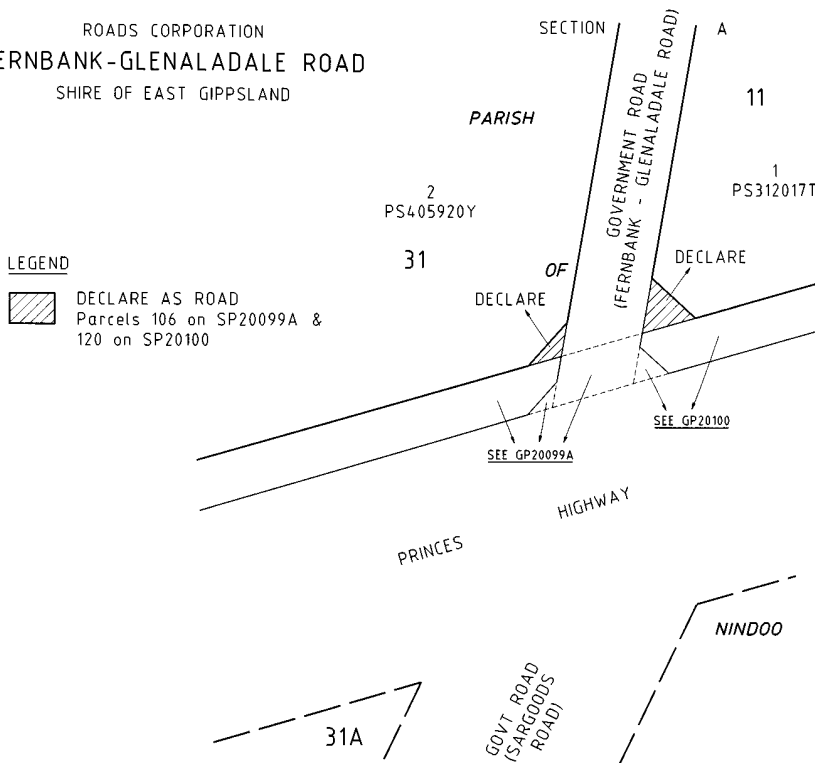

ROADS CORPORATION
EAST BOUNDARY TRACK
SHIRE OF EAST GIPPSLAND

LEGEND

 DECLARE AS ROAD
Parcel 101 on SP20099A

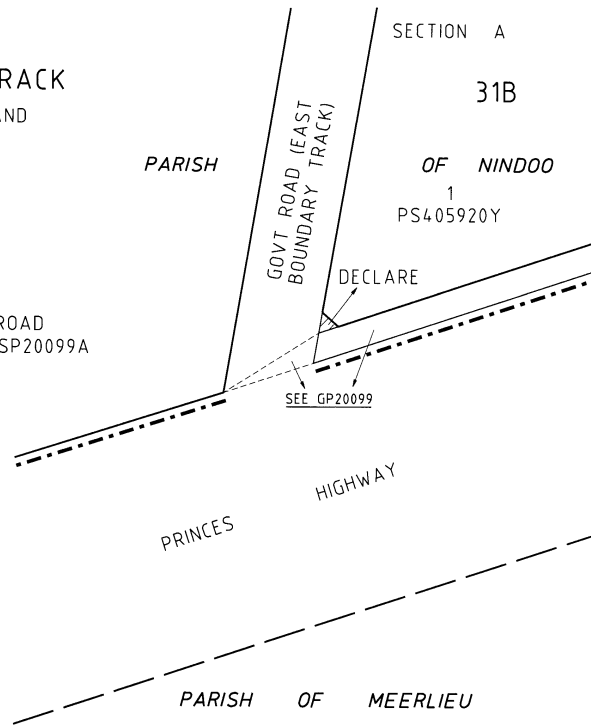

ROADS CORPORATION
ROAD
SHIRE OF EAST GIPPSLAND

LEGEND

 DECLARE AS ROAD
Parcels 125 on SP20100 &
141 on SP20101

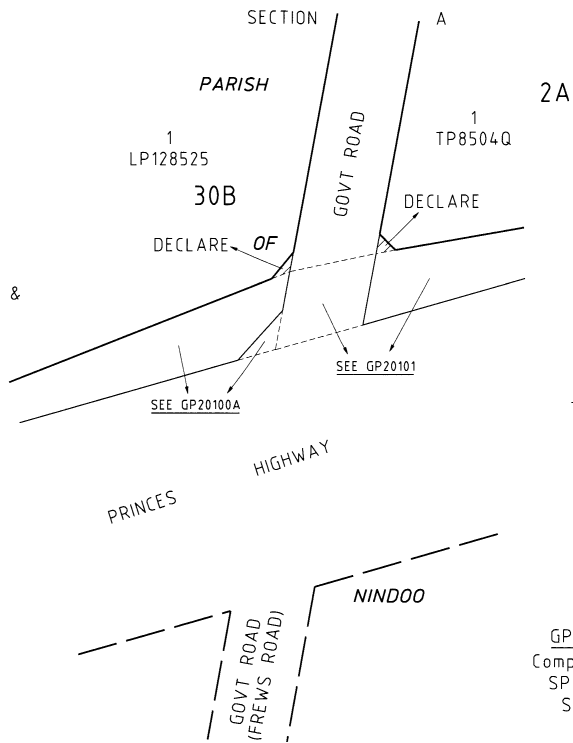

ROADS CORPORATION
ROAD
SHIRE OF EAST GIPPSLAND

LEGEND

 DECLARE AS ROAD
Parcel 146 on SP20101

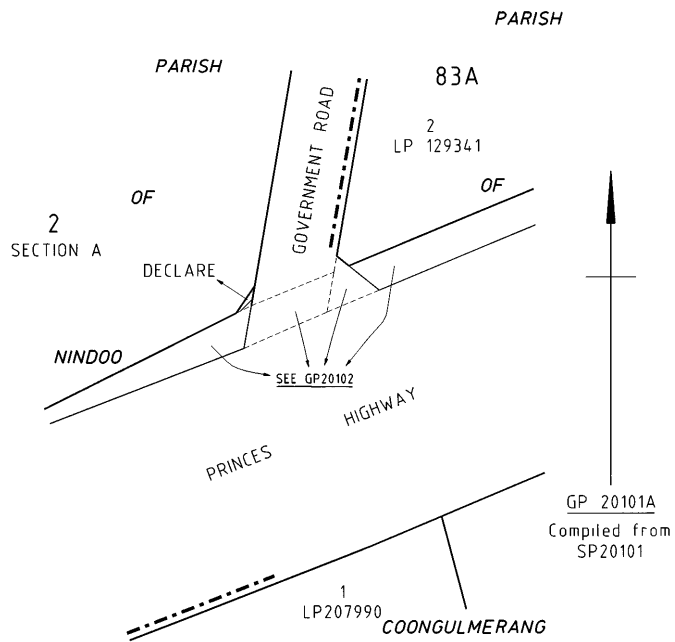

ROADS CORPORATION
MITTONS LANE
SHIRE OF EAST GIPPSLAND

GP 20251
Compiled from
SP20250A &
SP20251A

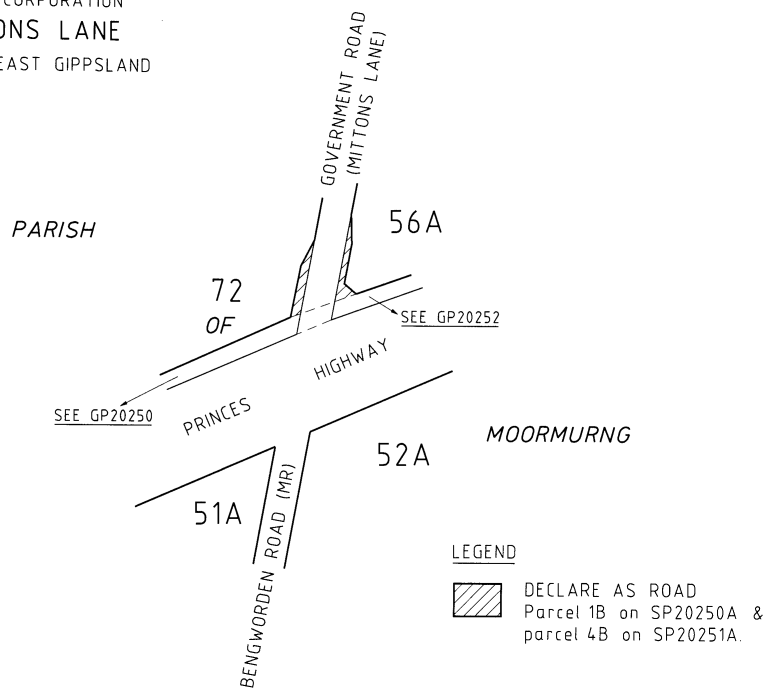

Dated 11 May 2004

DAVID ANDERSON
Chief Executive
Roads Corporation

Planning and Environment Act 1987

BAYSIDE PLANNING SCHEME

Notice of Approval of Amendment

Amendment C29 Part 2

The Minister for Planning has approved Amendment C29 Part 2 to the Bayside Planning Scheme.

The Amendment comes into operation on the date this notice is published in the Government Gazette.

The Amendment removes interim heritage controls from 8 properties and makes permanent the interim heritage controls applying to 13-15 Asling Street, Brighton ("Ithica").

A copy of the Amendment can be inspected, free of charge, during office hours, at the Department of Sustainability and Environment, Planning Information Centre, Upper Plaza, Nauru House, 80 Collins Street, Melbourne, and at the offices of the Bayside City Council, Corporate Centre, 76 Royal Avenue, Sandringham.

PAUL JEROME
Deputy Secretary
Built Environment
Department of Sustainability
and Environment

Planning and Environment Act 1987

BOROONDARA PLANNING SCHEME

Notice of Approval of Amendment

Amendment C16

The Minister for Planning has approved Amendment C16 to the Boroondara Planning Scheme.

The Amendment comes into operation on the date this notice is published in the Government Gazette.

The Amendment:

- rezones land known as 5-9 Burwood Road, Hawthorn described in Certificate of Title Volume 8730 Folio 924 to a Business 2 Zone;
- applies Design and Development Overlay Schedule 7 to the land.

The Minister has granted the following permit under Division 5 Part 4 of the Act:

Permit No *Description of land*

BOR/01/00235 5-9 Burwood Road, Hawthorn

A copy of the Amendment and permit can be inspected, free of charge, during office hours, at the Department of Sustainability and Environment, Planning Information Centre, Upper Plaza, Nauru House, 80 Collins Street, Melbourne, and at the offices of the Boroondara City Council, 8 Inglesby Road, Camberwell.

PAUL JEROME
Deputy Secretary
Built Environment
Department of Sustainability
and Environment

Planning and Environment Act 1987

GLENELG PLANNING SCHEME

Notice of Approval of Amendment

Amendment C11

The Minister for Planning has approved Amendment C11 to the Glenelg Planning Scheme.

The Amendment comes into operation on the date this notice is published in the Government Gazette.

The Amendment rezones land being part of Crown Allotments 14 and 15, Section 10, at the south-east corner of Fern and Hurd Streets, Portland from Industrial 3 Zone to Residential 1 Zone.

A copy of the Amendment can be inspected, free of charge, during office hours, at the Department of Sustainability and Environment, Planning Information Centre, Upper Plaza, Nauru House, 80 Collins Street, Melbourne, and at the offices of the Glenelg Shire Council, Customer Service Centre, Cliff Street, Portland.

PAUL JEROME
Deputy Secretary
Built Environment
Department of Sustainability
and Environment

Planning and Environment Act 1987

GLEN EIRA PLANNING SCHEME

Notice of Approval of Amendment

Amendment C35

The Minister for Planning has approved Amendment C35 to the Glen Eira Planning Scheme.

The Amendment comes into operation on the date this notice is published in the Government Gazette.

The Amendment corrects a number of anomalies and errors in the Glen Eira Planning Scheme.

A copy of the Amendment can be inspected, free of charge, during office hours, at the Department of Sustainability and Environment, Planning Information Centre, Upper Plaza, Nauru House, 80 Collins Street, Melbourne, and at the offices of the Glen Eira City Council, corner Glen Eira and Hawthorn Roads, Caulfield.

PAUL JEROME
Deputy Secretary
Built Environment
Department of Sustainability
and Environment

Planning and Environment Act 1987
WANGARATTA PLANNING SCHEME
Notice of Approval of Amendment
Amendment C13

The Minister for Planning has approved Amendment C13 to the Wangaratta Planning Scheme.

The Amendment comes into operation on the date this notice is published in the Government Gazette.

The Amendment applies a Heritage Overlay over identified properties and areas across the Wangaratta urban area, introduces a Heritage Policy to the Wangaratta Planning Scheme at Clause 22.12, and also amends Clause 21.05-1 of the Wangaratta Planning Scheme to make reference to the “Wangaratta Urban Area Heritage Study (2002)”.

A copy of the Amendment can be inspected, free of charge, during office hours, at the Department of Sustainability and Environment, Planning Information Centre, Upper Plaza, Nauru House, 80 Collins Street, Melbourne; the Department of Sustainability and Environment North Eastern regional office, 35 Sydney Road, Benalla; and at the offices of the Rural City of Wangaratta, Ovens Street, Wangaratta.

PAUL JEROME
Deputy Secretary
Built Environment
Department of Sustainability
and Environment

ORDERS IN COUNCIL

Fuel Emergency Act 1977

APPROVAL OF FORM AND TIME UNDER SECTION 8 (2)

Order in Council

The Governor in Council, acting under section 8 (2) of the **Fuel Emergency Act 1977** (the Act), hereby approves:

The form in the Schedule to this Order as the form in which every claim for compensation under the Act shall be made in respect of the state of emergency in relation to briquettes and associated fuel products declared in proclamations published in Government Gazettes S4, S7, S10, S19, S24, S30 and S37 of 2004; and

Thirty (30) days from the date on which this Order is published in the Government Gazette as the time within which every such claim for compensation shall be made.

This Order is effective from the day on which it is published in the Government Gazette.

Dated 18 May 2004

Responsible Minister
THEO THEOPHANOUS
Minister for Energy Industries

STEPHANIE LENN
Acting Clerk of the Executive Council

Schedule

APPROVED FORM UNDER SECTION 8 (2) OF THE FUEL EMERGENCY ACT 1977

Section 8 (1) of the **Fuel Emergency Act 1977** (the Act) provides that any person or body of persons who or which as the result of compliance with any direction prohibition or requisition addressed or directed under the Act to him or it or while complying with or being engaged in the carrying into effect of any such direction prohibition or requisition suffers loss damage or injury for which he is not otherwise indemnified shall be entitled to compensation under the Act.

Section 8 (2) of the Act provides that every claim for compensation under the Act shall be made in a form approved by the Governor in Council. This form has been approved by the

Governor in Council for use for claims in respect of the state of emergency in relation to briquettes and associated fuel products declared in proclamations published in Government Gazettes S4, S7, S10, S19, S24, S30 and S37 of 2004.

Section 8 (2) of the Act also provides that every claim for compensation under the Act shall be made within a time approved by the Governor in Council. The time approved by the Governor in Council for claims in respect of the state of emergency in relation to briquettes and associated fuel products declared in proclamations published in Government Gazettes S4, S7, S10, S19, S24, S30 and S37 of 2004 is thirty (30) days from the date on which the Order to which this form is the schedule is published in the Government Gazette.

In this form, "relevant direction" means a direction prohibition or requisition under the Act in respect of the state of emergency in relation to briquettes and associated fuel products declared in proclamations published in Government Gazettes S4, S7, S10, S19, S24, S30 and S37 of 2004.

Service of claim

The claim may be served by post. The address for service is:

Secretary to the Department of Infrastructure,
Department of Infrastructure, Nauru House,
80 Collins Street, Melbourne Vic. 3000

Details of claim

1. Name of claimant:
2. Address of claimant:
3. The amount of compensation claimed including a breakdown of each part:
4. The circumstances in which the loss damage or injury arose including a description of the cause of the loss damage or injury and identifying the relevant direction or directions:
5. The calculation of the compensation claimed:
6. List any right to compensation or indemnification which the claimant has, from any source other than section 8 of the Act, in relation to the loss damage or injury:

7. List any benefits which the claimant has received arising from any right to compensation or indemnification, other than pursuant to section 8 of the Act, in relation to the loss damage or injury;
8. Any supporting evidence on which the claimant relies in order to reach its assessments in relation to this claim must be attached, including, but not limited to the following:
 - business records for the past five years;
 - contracts with third parties prior to the issue of any relevant directions;
 - contracts with third parties which are entered into as a result of the issue of any relevant directions;
 - expenses incurred by the claimant as a result of the issue of any relevant directions;
 - details of any other claims for insurance or compensation which the claimant has made, other than pursuant to section 8 of the Act, in relation to the loss damage or injury;
 - details of any benefits received from any claims for insurance or compensation which the claimant has made other than pursuant to section 8 of the Act, in respect of the loss damage or injury; and
 - any other reports or documents not outlined above which the claimant intends to tender or the substance of which the claimant intends to adduce in evidence in any arbitration or court proceedings relating to this claim.

Crown Land (Reserves) Act 1978

**NOTICE OF INTENTION TO REVOKE
TEMPORARY RESERVATIONS**

The Governor in Council under section 10 of the **Crown Land (Reserves) Act 1978** gives notice of intention to revoke the following temporary reservations:

FUMINA — The temporary reservation by Order in Council of 25 January, 1984 of an area of 1.623 hectares being Crown Allotment 95A, Parish of Fumina as a site for public recreation. — (Rs 12505).

KATUNGA — The temporary reservation by Order in Council of 7 February, 1881 of an area of 6.07 hectares, more or less, of land in Section A, Parish of Katunga as a site for Water Supply purposes, revoked as to part by Orders in Council of 14 June 1967 and 2 July, 1974 so far as the balance remaining containing 4.068 hectares, more or less. — (Rs 1964).

MANSFIELD — The temporary reservation by Order in Council of 3 August, 1971 of an area of 1012 square metres of land in Section 32, Township of Mansfield, Parish of Mansfield as a site for Public purposes (Court House and Police Buildings), so far only as the portion containing 506 square metres being Crown Allotment 2001 as indicated by hatching on plan hereunder. (GP1471) — (Rs 8549).

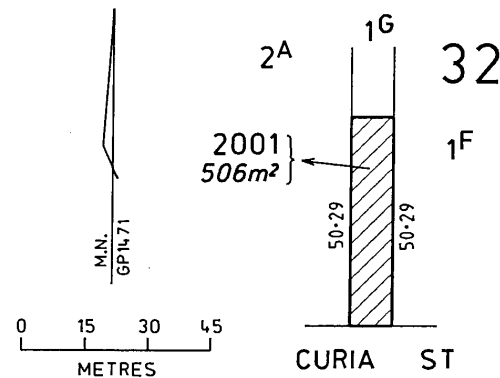

MANSFIELD — The temporary reservation by Order in Council of 6 February, 1865 of an area of 8094 square metres of land in Section 32, Township of Mansfield, (formerly Parish of Mansfield) as a site for Court House and Police Buildings, revoked as to part by various Orders, so far only as the portion containing 342 square metres being Crown Allotment 2002 as indicated by hatching on plan hereunder. (GP1471A) — (Rs 8549).

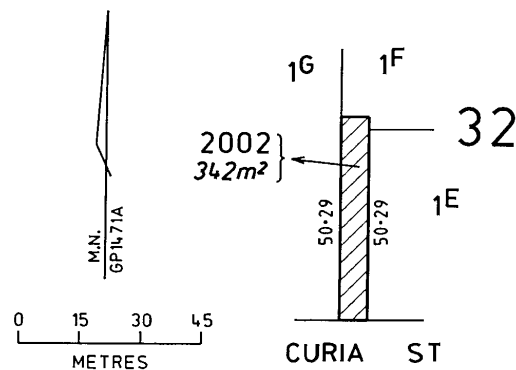

MIEPOLL — The temporary reservation by Order in Council of 5 July, 1886 of an area of 14.672 hectares of land in the Parish of Miepoll (formerly part of Crown Allotment 35) as a site for Water Supply purposes. — (Rs 13741)

WARRANTDYTE — The temporary reservation by Order in Council of 7 May, 1957 of an area of 2378 square metres of land in the Parish of Warrantdyte as a site for Police purposes. — (Rs 07549)

This Order is effective from the date on which it is published in the Government Gazette.

Dated 18 May 2004

Responsible Minister
MARY DELAHUNTY
Minister for Planning

STEPHANIE LENN
Acting Clerk of the Executive Council

Crown Land (Reserves) Act 1978

REVOCATION OF TEMPORARY RESERVATIONS

The Governor in Council under section 10 of the **Crown Land (Reserves) Act 1978** revokes the following temporary reservations:

ARCHDALE and BEALIBA — The temporary reservation by Order in Council of 15 May, 1888 of an area of 113.88 hectares of land in the Parishes of Archdale and Bealiba as a site for Water Supply purposes, revoked as to part by Order in Council of 19 June, 1911 SAVE AND EXCEPT the area containing 7687 square metres, being Crown Allotment 5A, Section A, Parish of Archdale as indicated by hatching on plan published in the Government Gazette on 25 March 2004 page 688. — (0607551).

BENDIGO — The temporary reservation by Order in Council of 25 July, 1887 of an area of 1.461 hectares of land in two separate portions in Sections 12 and 13, at Bendigo, Parish of Sandhurst (formerly City of Sandhurst, at White Hills) as a site for Public purposes, revoked as to part by Order in Council of 27 November 1979 so far only as the remaining part of northern reserve in Section 13 containing 2087 square metres, more or less. — (0617287).

COWES — The temporary reservation by Order in Council of 18 December, 1973 of an area of 859 square metres being Crown Allotment 13, Section 6, Township of Cowes, Parish of Phillip Island as a site for Public Purposes (Government Buildings). — (Rs 9855).

FRANKSTON — The temporary reservation by Order in Council of 28 February, 1876 of an area of 2.023 hectares of land in the Parish of Frankston (formerly part of portion 11) as a site for Public purposes (State School), revoked as to part by Order in Council of 10 July 1956 so far as the balance remaining containing 1.568 hectares, more or less. — (Rs 4843).

HORSHAM — The temporary reservation by Order in Council of 18 October, 1983 of an area of 5080 square metres of land being Crown Allotment 6A, Section 9, Parish of Horsham as a site for departmental depot. — (Rs 12473).

KILCUNDA — The temporary reservation by Order in Council of 21 January, 1997 of an area of 70 hectares, more or less, of the lands in the Township of Kilcunda and Parish of Woolamai as a site for Public Purposes (Rail Trail), so far only as the portions containing 9165 square metres being Crown Allotments 2002 and 2003, Township of Kilcunda as indicated by hatching on plan published in the Government Gazette on 18 March 2004, page 601. — (Rs 37146).

LILLIMUR SOUTH — The temporary reservation by Order in Council of 9 August, 1881 of an area of 42.525 hectares of land in the Township of Lillimur South, (formerly Parish of Lillimur) as a site for Camping and affording access to Water, revoked as to part by various Orders, so far as the balance remaining containing 32.934 hectares, more or less. — (Rs 5460).

LILLIMUR SOUTH — The withholding from sale, leasing and licensing and exception from occupation for residence or business under any miner's right or business license, by Order in Council of 26 February, 1877 of an area of 60.703 hectares, more or less, of land in the Township of Lillimur South (formerly Parish of Lillimur). — (Rs 5460).

LILLIPUT — The temporary reservation by Order in Council of 6 June 1892 of an area of 6.7 hectares of land in Section L, Parish of Lilliput as a site for Supply of Gravel, revoked as to part by Order in Council of 17 April, 1896 so far as the balance remaining containing 4.49 hectares, more or less. — (Rs 118875).

MANSFIELD — The temporary reservation by Order in Council of 10 May, 1983 of an area of 8094 square metres of land being Crown Allotment 23J, Parish of Mansfield as a site for Department of Crown Lands and Survey purposes, so far only as the portion containing 1500 square metres shown as Crown Allotment

2001, Parish of Mansfield on Original Plan No. 122067 lodged in the Central Plan Office. — (Rs 10573).

MILDURA — The temporary reservation by Order in Council of 16 December, 1947 of an area of 2.335 hectares of land in Section B, Parish of Mildura as a site for Hospital purposes, revoked as to part by Order in Council of 2 November 1977 so far as the balance remaining containing 8120 square metres. — (Rs 6084).

MOORNGAG — The temporary reservation by Order in Council of 28 May, 1968 of an area of 4679 square metres of land in the Parish of Moorngag as a site for Public Recreation. — (Rs 6644).

NATIMUK — The temporary reservation by Order in Council of 9 July, 1888 of an area of 4.047 hectares of land in the Parish of Natimuk (formerly portion of Crown Allotment 140) as a site for supply of Gravel. — (Rs 35148).

NURCOUNG — The temporary reservation by Order in Council of 18 November, 1889 of an area of 24.281 hectares of land in the Parish of Nurcung (formerly portion of Crown Allotment 39) as a site for Water Supply purposes, revoked as to part by Order in Council of 2 April 1963 so far as the balance remaining containing 16.175 hectares, more or less. — (Rs 01217).

WARRAGUL — The temporary reservation by Order in Council of 1 April, 1890 of an area of 6091 square metres of land in Section 3, Township of Warragul, Parish of Drouin East as a site for Police purposes, revoked as to part by Orders in Council of 30 March, 1971 and 11 June, 1997 so far as the balance remaining containing 4979 square metres, more or less. — (Rs 13845).

WICKLIFFE — The setting apart for Church of England purposes on 6 February, 1865 of an area of 4047 square metres more or less, of land being Crown Allotments 6 and 7, Section 9, Township of Wickliffe, Parish of Wickliffe South. — (0513578).

This Order is effective from the date on which it is published in the Government Gazette.

Dated 18 May 2004

Responsible Minister
MARY DELAHUNTY
Minister for Planning

STEPHANIE LENN
Acting Clerk of the Executive Council

Crown Land (Reserves) Act 1978

TEMPORARY RESERVATION
OF CROWN LANDS

The Governor in Council under section 4(1) of the **Crown Land (Reserves) Act 1978** temporarily reserves the following Crown lands which in his opinion are required for the purposes mentioned:—

MUNICIPAL DISTRICT OF THE
EAST GIPPSLAND SHIRE COUNCIL

BAIRNSDALE — Public purposes (Police purposes), 5084 square metres being Crown Allotment 2004, Township of Bairnsdale, Parish of Bairnsdale as shown on Original Plan No. 122047 lodged in the Central Plan Office. — (2013663).

MUNICIPAL DISTRICT OF THE
BASS COAST SHIRE COUNCIL

COWES — Public purposes (Community use), 864 square metres being Crown Allotment 18, Section 6, Township of Cowes, Parish of Phillip Island as shown on Original Plan No. 121654 lodged in the Central Plan Office. — (Rs 9855).

MUNICIPAL DISTRICT OF THE
FRANKSTON CITY COUNCIL

FRANKSTON — Public Recreation, 1.697 hectares, being Crown Allotment 8G, Parish of Frankston as indicated by hatching on plan hereunder. (GP1453) — (Rs 4843).

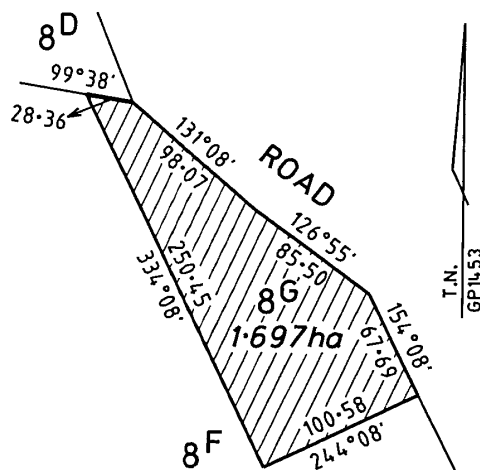

RACECOURSE AND RECREATION
RESERVE Rs 3645

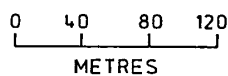

MUNICIPAL DISTRICT OF THE WEST WIMMERA SHIRE COUNCIL

LILLIMUR SOUTH — Conservation of an area of natural interest, total area 57.5 hectares, more or less, being Crown Allotments 2001, 2002 and 2003, Crown Allotment 2A of Section 1 and Crown Allotment 10 of Section 7, Township of Lillimur South, Parish of Lillimur as indicated by hatching on plan hereunder. (GP1346) — (02/L4-1728).

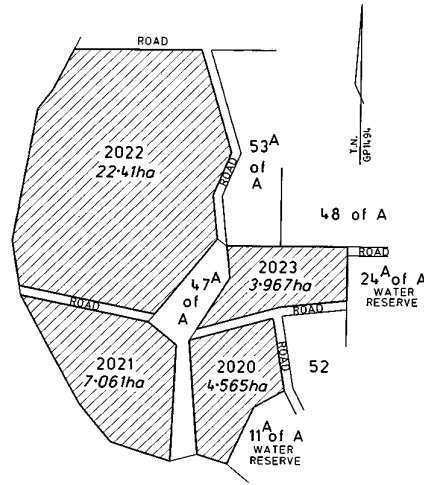
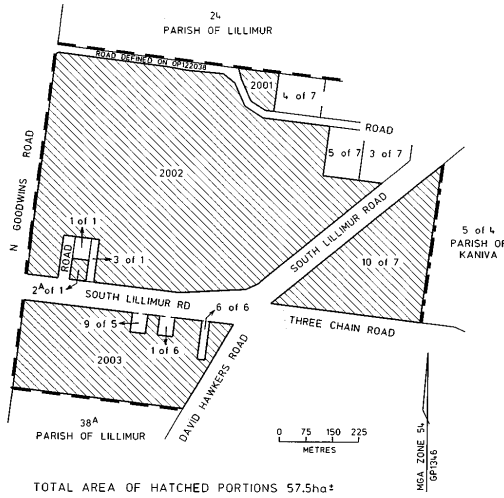

MUNICIPAL DISTRICT OF THE CITY OF WHITTLESEA

YAN YEAN — Cemetery purposes, 4.249 hectares, more or less, being Crown Allotment 2008, Parish of Yan Yeau as indicated by hatching on plan hereunder. (GP1481) — (Rs 37224).

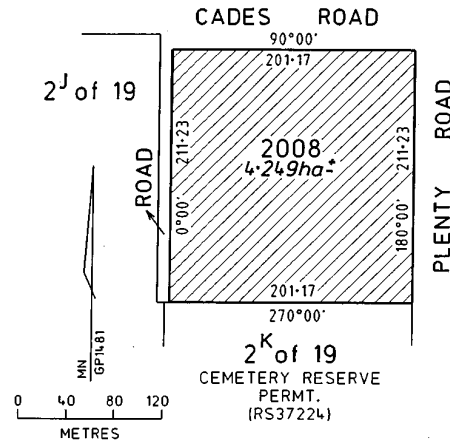

MUNICIPAL DISTRICT OF THE MILDURA RURAL CITY COUNCIL

MILDURA — Health and Aged Care purposes, 1.862 hectares, being Crown Allotment 2066, Parish of Mildura as indicated by hatching on plan hereunder. (GP1454) — (012013463).

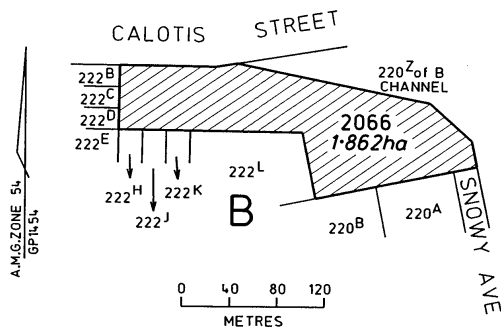

This Order is effective from the date on which it is published in the Government Gazette.

Dated 18 May 2004

Responsible Minister
MARY DELAHUNTY
Minister for Planning

STEPHANIE LENN
Acting Clerk of the Executive Council

MUNICIPAL DISTRICT OF THE GREATER SHEPPARTON CITY COUNCIL

SHEPPARTON — Management of wildlife, combined area 38 hectares, being Crown Allotments 2020, 2021, 2022 and 2023, Parish of Shepparton as indicated by hatching on plan hereunder. (GP1494) — (Rs 14003).

Land Act 1958

CLOSURE OF UNUSED ROAD

The Governor in Council under section 349 of the **Land Act 1958** and with the concurrence in writing of the municipality in which the road is situated and the owners of land adjoining the road closes the following unused road:

MUNICIPAL DISTRICT OF THE COLAC OTWAY SHIRE COUNCIL

AIRE — The road in the Parish of Aire being Crown Allotment 2011 as indicated by hatching on plan hereunder. (GP1493) — (L1-1277).

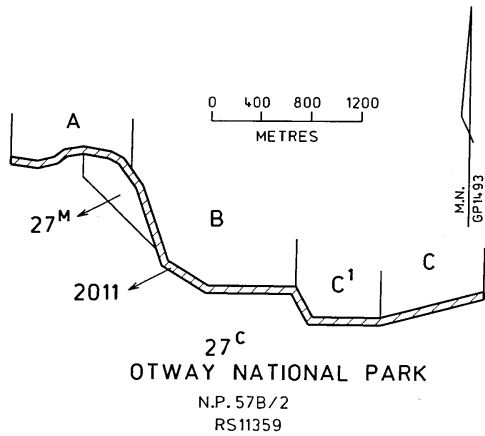

This Order is effective from the date on which it is published in the Government Gazette.

Dated 18 May 2004

Responsible Minister
MARY DELAHUNTY
 Minister for Planning

STEPHANIE LENN
 Acting Clerk of the Executive Council

Land Act 1958

CLOSURE OF UNUSED ROADS

The Governor in Council under section 349 of the **Land Act 1958** and with the concurrence in writing of the municipalities in which the roads are situated closes the following unused roads:

MUNICIPAL DISTRICT OF THE CENTRAL GOLDFIELDS SHIRE COUNCIL

ARCHDALE and BEALIBA — The roads in the Parishes of Archdale and Bealiba being Crown Allotment 2002, Parish of Archdale and

Crown Allotment 2003, Parish of Bealiba as indicated by hatching on plan hereunder. (GP1409B) — (0607551).

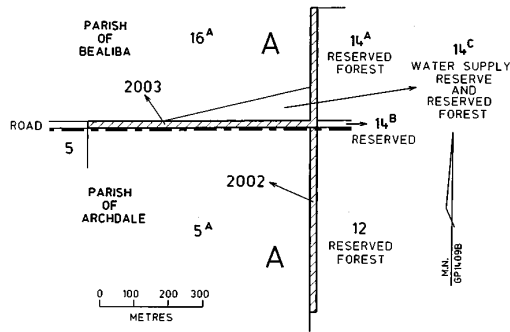

MUNICIPAL DISTRICT OF THE CITY OF WHITTLESEA

YAN YEAN — The road in the Parish of Yan Yeon being Crown Allotment 2007 as indicated by hatching on plan hereunder. (GP1479) — (Rs 37224).

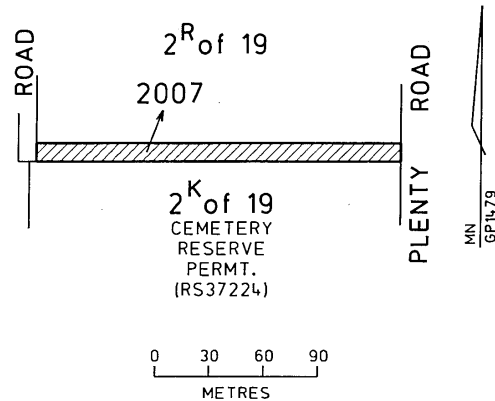

This Order is effective from the date on which it is published in the Government Gazette.

Dated 18 May 2004

Responsible Minister
MARY DELAHUNTY
 Minister for Planning

STEPHANIE LENN
 Acting Clerk of the Executive Council

This page left blank intentionally

**SUBORDINATE LEGISLATION ACT 1994
NOTICE OF MAKING OF STATUTORY
RULES**

Notice is hereby given under Section 17 (2) of the **Subordinate Legislation Act 1994** of the making of the following Statutory Rules:

- | | |
|--|--|
| <p>39. <i>Statutory Rule:</i> Associations Incorporation (Amendment) Regulations 2004</p> <p><i>Authorising Act:</i> Associations Incorporation Act 1981</p> <p><i>Date of making:</i> 18 May 2004</p> | <p>44. <i>Statutory Rule:</i> Drugs, Poisons and Controlled Substances (Division 2 Nurses Amendment) Regulations 2004</p> <p><i>Authorising Act:</i> Drugs, Poisons and Controlled Substances Act 1981</p> <p><i>Date of making:</i> 18 May 2004</p> |
| <p>40. <i>Statutory Rule:</i> Residential Tenancies (Amendment) Regulations 2004</p> <p><i>Authorising Act:</i> Residential Tenancies Act 1997</p> <p><i>Date of making:</i> 18 May 2004</p> | <p>45. <i>Statutory Rule:</i> Nurses (Amendment) Regulations 2004</p> <p><i>Authorising Act:</i> Nurses Act 1993</p> <p><i>Date of making:</i> 18 May 2004</p> |
| <p>41. <i>Statutory Rule:</i> Consumer Affairs (Product Safety) (Lighters) (Amendment) Regulations 2004</p> <p><i>Authorising Act:</i> Fair Trading Act 1999</p> <p><i>Date of making:</i> 18 May 2004</p> | <p>46. <i>Statutory Rule:</i> Building (Further Amendment) Regulations 2004</p> <p><i>Authorising Act:</i> Building Act 1993</p> <p><i>Date of making:</i> 18 May 2004</p> |
| <p>42. <i>Statutory Rule:</i> Financial Management Regulations 2004</p> <p><i>Authorising Act:</i> Financial Management Act 1994</p> <p><i>Date of making:</i> 18 May 2004</p> | <p>47. <i>Statutory Rule:</i> Subordinate Legislation (Building Regulations 1994 – Extension of Operation) Regulations 2004</p> <p><i>Authorising Act:</i> Subordinate Legislation Act 1994</p> <p><i>Date of making:</i> 18 May 2004</p> |
| <p>43. <i>Statutory Rule:</i> Drugs, Poisons and Controlled Substances (Amendment) Regulations 2004</p> <p><i>Authorising Act:</i> Drugs, Poisons and Controlled Substances Act 1981</p> <p><i>Date of making:</i> 18 May 2004</p> | <p>48. <i>Statutory Rule:</i> Road Safety (Drivers) (Demerit Points) Regulations 2004</p> <p><i>Authorising Act:</i> Road Safety Act 1986</p> <p><i>Date of making:</i> 18 May 2004</p> |
| <p>49. <i>Statutory Rule:</i> Road Safety (Vehicles) (Registration Fees) Regulations 2004</p> <p><i>Authorising Act:</i> Road Safety Act 1986</p> <p><i>Date of making:</i> 18 May 2004</p> | <p>50. <i>Statutory Rule:</i> Road Safety (Drivers) (Fees) Regulations 2004</p> <p><i>Authorising Act:</i> Road Safety Act 1986</p> <p><i>Date of making:</i> 18 May 2004</p> |

**SUBORDINATE LEGISLATION ACT 1994
NOTICE THAT STATUTORY RULES ARE
OBTAINABLE**

Notice is hereby given under Section 17 (3) of the **Subordinate Legislation Act 1994** that the following Statutory Rules were first obtainable from Information Victoria, 356 Collins Street, Melbourne on the date specified:

36. *Statutory Rule:* Fair Trading
(Amendment)
Regulations 2004
Authorising Act: Fair Trading Act
1999
Date first obtainable: 20 May 2004
Code A
37. *Statutory Rule:* Transfer of Land
(General)
Regulations 2004
Authorising Act: Transfer of Land
Act 1958
Date first obtainable: 20 May 2004
Code D
38. *Statutory Rule:* Road Safety
(Vehicles)
(Concession Fees)
Regulations 2004
Authorising Act: Road Safety Act
1986
Date first obtainable: 20 May 2004
Code A

**PRICING FOR SPECIAL GAZETTE,
PERIODICAL GAZETTE AND
VICTORIAN LEGISLATION**

Retail price varies according to the number of pages in each Victoria Government Special Gazette, Victoria Government Periodical Gazette and Victorian legislation. The table below sets out the prices that apply.

<i>Price Code</i>	<i>No. of Pages (Including cover and blank pages)</i>	<i>Price*</i>
A	1–16	\$3.70
B	17–32	\$5.50
C	33–48	\$7.55
D	49–96	\$11.75
E	97–144	\$15.20
F	145–192	\$17.95
G	193–240	\$20.70
H	241–288	\$22.05
I	289–352	\$24.80
J	353–416	\$29.00
K	417–480	\$33.10
L	481–544	\$38.60
M	545–608	\$44.10
N	609–672	\$49.65
O	673–736	\$55.10
P	737–800	\$60.65

**All Prices Include GST*

craftsmanpress

The *Victoria Government Gazette* is published by The Craftsman Press Pty Ltd with the authority of the Government Printer for the State of Victoria

© State of Victoria 2004

This publication is copyright. No part may be reproduced by any process except in accordance with the provisions of the Copyright Act.

Address all enquiries to the Government Printer for the State of Victoria
Level 2 1 Macarthur Street
Melbourne 3002
Victoria Australia

How To Order

Mail Order **Craftsman Press Pty Ltd**
125 Highbury Road
Burwood 3125
DX – 32510 Burwood



Telephone (03) 9926 1233



Fax (03) 9926 1292

email gazette@craftpress.com.au



Retail & Mail Sales **Information Victoria**
356 Collins Street
Melbourne 3000



Telephone 1300 366 356



Fax (03) 9603 9920



Retail Sales **City Graphics**
Level 1 520 Bourke Street
Melbourne 3000



Telephone (03) 9600 0977



Fax (03) 9600 0989

Recommended Retail Price \$1.95 (includes GST)

ISSN 0819-5471



9 770819 550287