



# **Victoria Government Gazette**

By Authority of Victorian Government Printer

**No. G 31 Thursday 29 July 2004**

[www.gazette.vic.gov.au](http://www.gazette.vic.gov.au)

---

**GENERAL**

---

---

**TABLE OF PROVISIONS**

Private Advertisements		National Estate Agents Pty Ltd	2118
Estates of Deceased Persons		R.A.C.V. Finance Limited – 2002	2118
A. B. Natoli Pty	2111	R.A.C.V. Finance Limited – 2003	2119
Abbott Stillman & Wilson	2111	Rennick & Gaynor Solicitors	
Aitken Walker & Strachan	2111	(Estate Joan P. Colville)	2119
Aughtersons	2111	Proclamations	2120
Borchard Moore	2112	Government and Outer Budget Sector	
Bruhn & Co.	2112	Agencies Notices	2122
Cassidys Morrison & Teare	2112	Orders in Council	2144
Chessell Williams	2112	Acts:	
Davine Fitzpatrick	2112	Crown Land (Reserves);	
Dwyer Mahon & Robertson	2112	Drugs, Poisons and	
John Stewart	2113	Controlled Substances;	
Lyttletons	2113	Land;	
Phillips & Wilkins	2113	Parliamentary Committees	
Polites & Carroll	2113		
Sengphas	2114		
Verhoeven & Curtain	2114		
Wills & Probate Victoria	2114		
Wisewoulds	2114		
Sales by the Sheriff			
Anthony Borg & Brenda Ann Borg	2114		
Sonia Pecchiari	2114		
Ian Douglas Tankard	2115		
Unclaimed Moneys			
CitiPower Pty	2116		
Crompton & Green Real Estate Pty Ltd	2116		
Daylesford Real Estate	2117		
Geoff Lewtas Real Estate Pty Ltd	2117		
Mobil Oil Australia Pty Ltd	2117		

---

**Advertisers Please Note**

As from 29 July 2004

The last Special Gazette was No. 174 dated 27 July 2004.

The last Periodical Gazette was No. 1 dated 17 June 2004.

---



---

**How To Submit Copy**

- See our webpage [www.craftpress.com.au](http://www.craftpress.com.au)
  - or contact our office on 9926 1233  
between 8.30 am and 5.30 pm Monday to Friday
- 

---

**Copies of recent Special Gazettes can now be viewed at the following display cabinets:**

- 1 Treasury Place, Melbourne (behind the Old Treasury Building), and
  - Craftsman Press Pty Ltd, 125 Highbury Road, Burwood 3125 (front of building).
-

**PRIVATE ADVERTISEMENTS**

PHILIP JOHN ARKLE, late of 124-126 Princes Highway, Port Fairy, Victoria, motelier, deceased.

Creditors, next-of-kin and others having claims in respect of the estate of the abovementioned deceased, who died on 5 August 2003, are required by Dawn Leanne-Rose Walterfang, the executor of the deceased's Will, to send particulars of their claim to the said executor care of the undermentioned solicitors by a date not later than two months from the date of publication hereof, after which date she will convey or distribute the assets, having regard only to the claims of which she then has notice.

A. B. NATOLI PTY, solicitors,  
24 Cotham Road, Kew 3101.

Re: CLARE ROSEMARY BARNES, late of 1 Woodruff Street, Kensington, student, deceased.

Creditors, next-of-kin and others having claims in respect of the estate of the deceased, who died on 14 March 2004, are required by the trustee, National Australia Trustees Limited of Level 5, 800 Bourke Street, Docklands, Victoria, to send particulars to the trustee by 2 October 2004 after which date the trustee may convey or distribute the assets, having regard only to the claims of which the trustee has notice.

ABBOTT STILLMAN & WILSON, solicitors,  
Level 4, 575 Bourke Street, Melbourne 3000.

Re: FLORENCE AGNES WILSON, late of Corrong Village Hostel, 100 Toole Street, Hopetoun, but formerly of 68 Mandeville Street, Hopetoun, widow, deceased.

Creditors, next-of-kin and others having claims in respect of the estate of the deceased, who died on 20 April 2004, are required by the trustee, Trust Company of Australia Limited in the Will called the Union-Fidelity Trustee Company of Australia, 151 Rathdowne Street, Carlton South, Victoria, trust company, to send particulars to the trustee by 2 October 2004 after which date the trustee may convey or distribute the assets, having regard only to the claims of which the trustee has notice.

ABBOTT STILLMAN & WILSON, solicitors,  
Level 4, 575 Bourke Street, Melbourne 3000.

Re: DESMOND ROBERT ALLISON, late of 9 Adam Street, Bentleigh, retired, deceased.

Creditors, next-of-kin and others having claims in respect of the estate of the deceased, who died on 27 April 2004, are required by the trustee, Equity Trustees Limited (ACN 46 004 031 298) in the Will called the Equity Trustees Executors and Agency Company Limited, of Level 2, 575 Bourke Street, Melbourne, Victoria, to send particulars to the trustee by 1 October 2004 after which date the trustee may convey or distribute the assets, having regard only to the claims of which the trustee has notice.

AITKEN WALKER & STRACHAN, solicitors,  
2nd Floor, 114 William Street, Melbourne 3000.

Re: REGINALD HAROLD YOUNG, in the Will called REGINALD YOUNG, late of 1 Patterson Street, Brunswick, Victoria, retired, deceased.

Creditors, next-of-kin and others having claims in respect of the estate of the deceased, who died on 17 April 2004, are required by the trustees, Robert Hugh Davey of 114 William Street, Melbourne, Victoria, partner, and Andrew James Moig of 3 Patterson Street, Brunswick, Victoria, IT specialist, to send particulars to the trustees by 1 October 2004 after which date the trustees may convey or distribute the assets, having regard only to the claims of which the trustees have notice.

AITKEN WALKER & STRACHAN, solicitors,  
2nd Floor, 114 William Street, Melbourne 3000.

Re: MARY LILIAN JONES, late of 13 Orana Crescent, Chelsea, Victoria, pensioner, deceased.

Creditors, next-of-kin and others having claims in respect of the estate of the abovenamed deceased, who died on 29 April 2004, are required by the executrix, Kathryn Mary Ensor of 5 Aruma Court, Chelsea, Victoria, to send particulars thereof to her care of the office of Messrs Aughtersons, 267 Maroondah Highway, Ringwood, with sixty days from the date of publication of this notice after which the executrix will distribute the

estate having regard only to claims of which she has notice.

AUGHTERSONS,  
current practitioners for the executrix,  
267 Maroondah Highway, Ringwood 3134.

---

Re: LISLE JULIAN COX, late of Waverley Hill Supportive Care Pty Ltd, Room 32, 946-952 Ferntree Gully Road, Wheelers Hill, Victoria, but formerly of 126 Albany Drive, Mulgrave, Victoria, retired fireman, deceased.

Creditors, next-of-kin and others having claims in respect of the estate of the deceased, who died on 30 April 2004, are required by the trustee, Lisle Norman Cox of 7 King Orchid Drive, Langwarrin, Victoria, printer, to send particulars to the trustee by 11 October 2004 after which date the trustee may convey or distribute the assets, having regard only to the claims of which the trustee has notice.

BORCHARD & MOORE, solicitors,  
44 Douglas Street, Noble Park 3174.

---

MARGARET ANN ELLIOTT, late of 47 Peers Crescent, Ocean Grove, Victoria, deceased. Creditors, next-of-kin and others having claims in respect of the estate of the deceased, who died on 21 February 2004, are required by the personal representatives, Deborah Doreen Gee of 157 The Avenue, Ocean Grove, Victoria, teacher's aide, and Albert Trevor Bruhn of 32 Myers Street, Geelong, Victoria, solicitor, to send particulars to them by 9 October 2004 after which date the personal representatives may convey or distribute the assets having regard only to the claims of which they then have notice.

Dated 14 July 2004

BRUHN & CO., solicitors,  
32 Myers Street, Geelong.

---

Re: CRAIG PHILLIP MORRIS, late of 8 O'Sullivan's Road, Huntly, Victoria, retired, deceased.

Creditors, next-of-kin and others having claims in respect of the estate of the deceased, who died on 7 January 2004, are required by the trustee, Timothy Cullen Stuart of 82 Melville Street, Numurkah, Victoria, solicitor, to send particulars to the trustee by 15 October 2004 after which date the trustee may convey or

distribute the assets, having regard only to the claims of which the trustee has notice.

CASSIDYS MORRISON & TEARE, solicitors,  
82 Melville Street, Numurkah 3636.

---

Re: Estate of PHYLLIS JOAN LAURITZ.

Creditors, next-of-kin and others having claims against the estate of PHYLLIS JOAN LAURITZ, late of 16A Blackwood Street, Murrumbena, Victoria, widow, deceased, who died on 5 February 2004, are requested to send particulars of their claims to the executors care of the undermentioned solicitors by 30 September 2004, after which date they will distribute the assets having regard only to the claims on which date they then have notice.

CHESSELL WILLIAMS, solicitors,  
379 Collins Street, Melbourne 3000

---

Re: DARYL JOHN HOLDSWORTH, late of 2-15 Railway Crescent, Moe, Victoria, timber mill employee, deceased.

Creditors, next-of-kin and others having claims in respect of the estate of the deceased, who died on 26 November 2003, are required by the trustee, Mary Priscilla Holdsworth of 38 Chapmans Road, Trafalgar, Victoria, home duties, mother of the deceased, to send particulars to the trustee care of the below-mentioned solicitors by 27 September 2004 after which date the trustees may convey or distribute the assets, having regard only to the claims of which the trustees have notice.

DAVINE FITZPATRICK, solicitors,  
52 Albert Street, Moe.

---

Re: Estate of ARCHIBALD McARTHUR.

Creditors, next-of-kin or others having claims in respect of the estate of ARCHIBALD McARTHUR, late of Sea Lake in the State of Victoria, farmer, deceased, who died on 11 July 1962, are to send particulars of their claim to the executor care of the undermentioned legal practitioners by 8 October 2004 after which the executor will distribute the assets having regard only to the claims of which he then has notice.

DWYER MAHON & ROBERTSON,  
legal practitioners,  
Beveridge Dome, 194-208 Beveridge Street,  
Swan Hill.

---

Re: Estate of PATRICIA MARGAUX RENNEY.

Creditors, next-of-kin or others having claims in respect of the estate of PATRICIA MARGAUX RENNEY, late of 10 Poole Boulevard, Swan Hill in the State of Victoria, married woman, deceased, who died on 25 April 2004, are to send particulars of their claim to the executors care of the undermentioned legal practitioners by 15 October 2004 after which the executors will distribute the assets having regard only to the claims of which they then have notice.

DWYER MAHON & ROBERTSON,  
legal practitioners,  
Beveridge Dome,  
194–208 Beveridge Street, Swan Hill.

---

Re: Estate of PATRICIA MERLE MCKENZIE.

Creditors, next-of-kin or others having claims in respect of the estate of PATRICIA MERLE MCKENZIE, late of 12 Jacaranda Crescent, Lake Boga in the State of Victoria, pensioner, deceased, who died on 22 June 2004, are to send particulars of their claim to the executor care of the undermentioned legal practitioners by 8 October 2004 after which the executor will distribute the assets having regard only to the claims of which he then has notice.

DWYER MAHON & ROBERTSON,  
legal practitioners,  
Beveridge Dome, 194–208 Beveridge Street,  
Swan Hill.

---

Creditors, next-of-kin and others having claims in respect of the Will of CARMELA VENTIERI, late of 2 Lauriston Court, Mulgrave, Victoria, widow, deceased, who died on 17 June 2004, are requested to send particulars of their claims to the executor, Adoro Aldo Ventieri, care of the undermentioned legal practitioner by 30 September 2004 after which date he will distribute the assets having regard only as to the claims of which he then has notice.

JOHN STEWART, legal practitioner,  
290 Racecourse Road, Newmarket.

---

RUBY OLIVE SMITH, late of 8/406 Station Street, Bonbeach, Victoria, secretary, deceased.

Creditors, next-of-kin and others having claims in respect of the estate of the deceased, who died on 21 May 2004, are required by the executor, Donald Maxwell Smith, to send particulars to him care of the undermentioned solicitors by a date not later than two months from the date of publication hereof after which date the executor may convey or distribute the assets, having regard only to the claims of which he then has notice.

LYTTLETONS, solicitors,  
53 Marcus Road, Dingley.

---

Re: FLORENCE KATHLEEN DAVIS, late of 22 Sims Street, Pascoe Vale, Victoria, widow, deceased.

Creditors, next-of-kin and others having claims in respect of the estate of the deceased, who died on 27 May 2004, are required by the trustees, Lenore Carole O'Shannassy of 1/255 Seaford Road, Victoria, home duties, daughter and Gary Leonard Davis of 22 Sims Street, Pascoe Vale, Victoria, home carer, son, to send particulars to the trustees by 29 September 2004 after which date the trustees may convey or distribute the assets, having regard only to the claims of which the trustees have notice.

PHILLIPS & WILKINS, solicitors,  
823 High Street, Thornbury 3071.

---

Creditors, next-of-kin and others having claims against the estate of NICHOLAS BUNNEY, late of 304 Springvale Road, Donvale, Victoria, who died on 22 June 2002, are required by the executors, Jacqueline Louise Whiley of 28 Glen Avenue, Randwick, New South Wales and Jane Idith Bunney of 304 Springvale Road, Donvale, Victoria, to send detailed particulars of their claim to the said executors, care of Polites & Carroll, solicitors, of Level 8, 150 Queen Street, Melbourne, Victoria by 7 October 2004, after which date the executors will proceed to distribute the estate having regard only to the claims of which they have notice.

POLITES & CARROLL, solicitors,  
Level 8, 150 Queen Street, Melbourne.

---

Re: DONALD NORMAN JOHNSTON, late of High Street, Navarre, Victoria, but formerly of Barkly, pensioner, deceased.

Creditors, next-of-kin and others having claims in respect of the estate of the deceased, who died on 26 January 2004, are required by the trustee, Evelyn Joy Kingston in the Will called Evelyn Joy Brewster of 27 Cypress Street, Stawell, Victoria, to send particulars to the trustee care of her solicitors by 28 September 2004 after which date the trustee may convey or distribute the assets, having regard only to the claims of which the trustee has notice.

SENGPHAS, solicitors,  
153 Main Street, Stawell 3380.

LESLIE ALFRED BARRETT, late of Ti Tree Gardens, 34A Balaka Street, Rosebud West in the State of Victoria, pensioner, deceased.

Creditors, next-of-kin and others having claims in respect of the estate of the deceased, who died on 18 March 2004, are required by the personal representative, Jacqueline Patricia Good of 32 Southwell Avenue, Newborough, to send particulars to her, care of the undermentioned solicitors by 28 September 2004 after which date the personal representative may convey or distribute the assets, having regard only to the claims of which she then has notice.

VERHOEVEN & CURTAIN, solicitors,  
136 Commercial Road, Morwell.  
Suite 4, 46 Haigh Street, Moe.

Re: ANNA SCHEPUREK, late of 67 Woomack Road, Carnegie, Victoria.

Creditors, next-of-kin and others having claims in respect of the estate of the deceased, who died on 12 May 2004, are required to send particulars of their claims to the executor C/- Wills & Probate Victoria, GPO Box 1946, Melbourne 3001 by 29 October 2004 after which date the executor may convey or distribute the assets having regard only to the claims of which she may then have notice.

WILLS & PROBATE VICTORIA, lawyers,  
Level 5, 360 Little Bourke Street, Melbourne.

LAVINA MARY McCANDLISH, late of 854A Centre Road, Bentleigh East, Victoria, widow, deceased.

Creditors, next-of-kin and others having claims in respect of the estate of the abovenamed deceased, who died on 27 May 2004, are required by the executors, Malcolm Alexander John McCandlish of 3 Anderson Street, Malvern East, Victoria and Diane Estelle Hunter of 5/17 Clarke Street, Bowral, New South Wales, to send particulars to the executors by 1 October 2004 after which date the executors intend to convey or distribute the assets of the estate having regard only to the claims of which the executors may have notice.

WISEWOULDS, solicitors,  
459 Collins Street, Melbourne.

In the Supreme Court of the State of Victoria  
SALE BY THE SHERIFF

On Wednesday 25 August 2004 at 2.30 p.m. at the Sheriff's Office, 8-20 King Street, Oakleigh. (Unless process be stayed or satisfied).

All the estate and interest (if any) of Anthony Borg and Brenda Ann Borg of 6 Mullum Drive, Donvale, joint proprietors of an estate in fee simple in the land described on Certificate of Title Volume 9702, Folio 669 upon which is erected a residence known as 6 Mullum Drive, Donvale.

Registered Mortgage No. X226127F and Covenant in Instrument M519313G affect the said estate and interest.

Terms – Cash/Eftpos  
(Debit Cards only – No Credit Cards).  
SW-03-008466-6

Dated 22 July 2004

V. PARKIN  
Sheriff's Office

In the Supreme Court of the State of Victoria  
SALE BY THE SHERIFF

On Wednesday 25 August 2004 at 2.30 p.m. at the Sheriff's Office, 8-20 King Street, Oakleigh. (Unless process be stayed or satisfied).

All the estate and interest (if any) of Sonia Pecchiari of 42 Stagecoach Crescent, Sydenham, joint proprietor with Brett Graeme

Walker of an estate in fee simple in the land described on Certificate of Title Volume 10242, Folio 824 upon which is erected a house known as 42 Stagecoach Crescent, Sydenham.

Registered Mortgage No. AB085723Y affects the said estate and interest.

Terms – Cash/Eftpos  
(Debit Cards only. No Credit Cards).  
SW-03-010407-0

Dated 22 July 2004

V. PARKIN  
Sheriff's Office

---

In the Supreme Court of the State of Victoria  
SALE BY THE SHERIFF

On Wednesday 25 August 2004 at 2.30 p.m. at the Sheriff's Office, 8–20 King Street, Oakleigh. (Unless process be stayed or satisfied).

All the estate and interest (if any) of Ian Douglas Tankard of 1 Creamery Road, Toolern Vale, proprietor of an estate in fee simple in the land described on Certificate of Title Volume 8113, Folio 376 upon which is erected a shed and small bungalow known as 1 Creamery Road, Toolern Vale.

Terms – Cash/Eftpos  
(Debit Cards only. No Credit Cards).  
SW-04-003865-8

Dated 22 July 2004

V. PARKIN  
Sheriff's Office

---



**Unclaimed Moneys Act 1962**

Register of Unclaimed Moneys held by the —

<i>Name of Owner on Books and Last Known Address</i>	<i>Total Amount Due to Owner</i>	<i>Description Of Unclaimed Money</i>	<i>Date when Amount first became Payable</i>
<b>CITIPOWER PTY</b>			
	\$		
Terry Rhodes, PO Box 963, Woollahra	119.15	Cheque	17/09/01
Colonial Property Management P/L, C/- Geoff Rudderham, PO Box 866J, Melbourne	145.00	"	07/05/01
Mayne Nickless Couriers Systems, PO Box 7245, St Kilda Road	199.93	"	10/08/01
Vicstate Utilities Drafting Pty Ltd, Suite19/653 Mountain Highway, Bayswater	246.40	"	13/07/01
Parks Victoria, Level 10, 535 Bourke St, Melbourne	250.85	"	24/09/01
Wright Information Technology, 19 Avondale Rd, Preston	268.00	"	30/07/01
Jim Papadimitriou, PO Box 2106, Templestowe	283.75	"	26/07/01
Mondo Victoria P/L, 4 Florence Street, Brunswick	323.50	"	27/09/01
Catherine Wilton, C/- Matthew Dudakov, 721 Toorak Road, Kooyong	368.65	"	13/09/01
E. A. Technology Ltd, C/- J-Tech Consulting, PO Box 787, Avalon Beach	780.00	"	17/05/01
TNT Australia Pty Ltd, PO Box 5003, Garden City	844.40	"	11/07/01
SAS Trustee Corporation, C/- Colliers Jardine, L32, 367 Collins Street, Melbourne	862.10	"	14/08/01
IBM Global Services, C/- Ross Litchfield, Locked Bag 1999, Ballarat	6,313.90	"	11/07/01

04239

CONTACT: CAROLINE NGUYEN, PHONE: (03) 9683 4404.

**Unclaimed Moneys Act 1962**

Register of Unclaimed Moneys held by the —

<i>Name of Owner on Books and Last Known Address</i>	<i>Total Amount Due to Owner</i>	<i>Description Of Unclaimed Money</i>	<i>Date when Amount first became Payable</i>
<b>COMPTON &amp; GREEN REAL ESTATE PTY LTD</b>			
	\$		
Anthony's Garden Maintenance Service, 1A Irwin Avenue, Altona North	125.00	Cheque	22/01/03

04241

CONTACT: DENISE FUNSTON OR SHELLEY LOUEY, PHONE: (03) 9397 1600.



**Unclaimed Moneys Act 1962**

Register of Unclaimed Moneys held by the —

<i>Name of Owner on Books and Last Known Address</i>	<i>Total Amount Due to Owner</i>	<i>Description Of Unclaimed Money</i>	<i>Date when Amount first became Payable</i>
DAYLESFORD REAL ESTATE			
	\$		
A. & A. Fistic, 35 Wahroonga Crescent, Greensborough 04247 CONTACT: PAUL JOHNSTON, PHONE: (03) 5348 1122.	264.00	Cheque	11/03/03

**Unclaimed Moneys Act 1962**

Register of Unclaimed Moneys held by the —

<i>Name of Owner on Books and Last Known Address</i>	<i>Total Amount Due to Owner</i>	<i>Description Of Unclaimed Money</i>	<i>Date when Amount first became Payable</i>
GEOFF LEWTAS REAL ESTATE PTY LTD			
	\$		
A. Sivasriamphai, 24/1 Flagstaff Lane, West Melbourne P. McLeod and F. Ansell, Apartment 17/2nd Floor, Country Appartments, Stanley Vill Road, Stanley, Hong Kong	250.00	Cheque	17/10/02
Mr Daniel Gilling, C/- 3 Anatol Place, Gordon, NSW	127.95	"	23/01/03
	250.00	"	06/03/03
04236 CONTACT: GEOFF LEWTAS, PHONE: (03) 5263 2214.			

**Unclaimed Moneys Act 1962**

Register of Unclaimed Moneys held by the —

<i>Name of Owner on Books and Last Known Address</i>	<i>Total Amount Due to Owner</i>	<i>Description Of Unclaimed Money</i>	<i>Date when Amount first became Payable</i>
MOBIL OIL AUSTRALIA PTY LTD			
	\$		
RAF#1 Mobil Minchinbury, Great Western Hwy & Angus Ave, Minchinbury, NSW 146005 (015424) Repco Auto Parts, 229 Marion Road, Marlestone, SA	8,376.17	Cheque	21/05/99
	6,000.00	"	24/12/99

v134180 UBD Business to Business, 64 Talavera Road, Macquarie Centre, NSW	2,334.64	”	04/06/99
142129 Trident Woods Pty Ltd, 2nd Floor, 2 Princes Street, Port Melbourne	1,125.00	”	08/10/99
104830 ACT Revenue Office, Locked Bag 8300, Canberra	197.09	”	29/02/00
126338 D. & E. Potter, 19–21 Settlement Road, Belmont	157.04	”	27/09/00

04235

CONTACT: ANNE BAYTON, PHONE: (07) 3213 7871.

**Unclaimed Moneys Act 1962**

Register of Unclaimed Moneys held by the —

<i>Name of Owner on Books and Last Known Address</i>	<i>Total Amount Due to Owner</i>	<i>Description Of Unclaimed Money</i>	<i>Date when Amount first became Payable</i>
NATIONAL ESTATE AGENTS PTY LTD			
	\$		
GIO Business Insurance, PO Box 364, Glen Waverley	1,126.59	Cheque	07/09/02
Pearsons Solicitors, 258 Keilor Road, Essendon	845.00	”	21/10/02

04249

CONTACT: RITA MONTALTO, PHONE: (03) 9629 7555.

**Unclaimed Moneys Act 1962**

Register of Unclaimed Moneys held by the —

<i>Name of Owner on Books and Last Known Address</i>	<i>Total Amount Due to Owner</i>	<i>Description Of Unclaimed Money</i>	<i>Date when Amount first became Payable</i>
R.A.C.V. FINANCE LIMITED – 2002			
	\$		
Mrs Audrey Matthews, Simons Hill Rd, Darraweit Guim	10,000.00	Debenture Stock	08/11/01
Estate of Rex Matthews, A. & P. Matthews Trustees, Simons Hill Road, Darraweit Guim	10,000.00	”	08/10/00
Mr Simon Dugelay, Flat 1, St James Court, 331 Bethnal Green Road, London, E2 6LG	200.00	”	29/09/96
Estate Russell-Pell, C/- Shaddick Owens, PO Box 515, Busselton, WA	200.00	”	18/10/94
Mrs Lucy Morrison, 54/20 Grant Street, East Brighton	10,000.00	”	25/02/00
Mrs Lucy Morrison, 54/20 Grant Street, East Brighton	5,000.00	”	17/09/01

Mrs Aileen Kelly, 2 Carrigal Street, Balwyn Dobie Pty Ltd,	10,000.00	''	21/08/97
C/- A. K. Wells, PO Box 61, Mortdale, NSW Estate of Pamela & Walter Power,	600.00	''	22/02/97
C/- Mahonys Solicitors, Attn: Peter Mahony, 400 Collins Street, Melbourne	3,000.00	''	04/08/01
Mr Erno Fejes, PO Box 403, South Yarra	600.00	''	12/02/00
Mr Erno Fejes, PO Box 403, South Yarra	700.00	''	12/02/00
Mr John C. & Mrs Niki Edwards, Unit 2, 22 Montgomery Avenue, Main Beach, Qld	60,000.00	''	30/03/98
Mr Graeme Addicott, 113 Dooring Street, Dickson, ACT	2,300.00	''	01/06/01

04227

CONTACT: INVESTMENT OFFICER, PHONE: (03) 9790 2939 OR 13 15 10.

**Unclaimed Moneys Act 1962**

Register of Unclaimed Moneys held by the —

<i>Name of Owner on Books and Last Known Address</i>	<i>Total Amount Due to Owner</i>	<i>Description Of Unclaimed Money</i>	<i>Date when Amount first became Payable</i>
R.A.C.V. FINANCE LIMITED – 2003			
	\$		
Aust Early Childhd Assoc., C/- B. O. O'Sullivan, 9–11 Stewart Street, Richmond	5,000.00	Debenture Stock	20/04/03
Miss Maria C. Virgona, 83 Nicholas Street, Newtown	1,000.00	''	07/06/03
Miss Maria C. Virgona, 83 Nicholas Street, Newtown	3,000.00	''	01/03/03
Mrs Purificacion Bauer, Unit 3, 18 Lydia St, Plympton, SA	5,700.00	''	19/02/03

04226

CONTACT: INVESTMENT OFFICER, PHONE: (03) 9790 2939 OR 13 15 10.

**Unclaimed Moneys Act 1962**

Register of Unclaimed Moneys held by the —

<i>Name of Owner on Books and Last Known Address</i>	<i>Total Amount Due to Owner</i>	<i>Description Of Unclaimed Money</i>	<i>Date when Amount first became Payable</i>
RENNICK & GAYNOR SOLICITORS RE: ESTATE OF JOAN PILLEY COLVILLE			
	\$		
Colville, Charles James Robertson, Chemin de Masmolene, 30700 Vallabrix, France	5,020.03	Cheque	07/07/89

04224

CONTACT: JOANNE HAZELDENE, PHONE: (03) 9813 1911.

**PROCLAMATIONS**

**Local Government  
(Democratic Reform) Act 2003**

**PROCLAMATION OF COMMENCEMENT**

I, Marigold Southey, Lieutenant-Governor of Victoria, as the Governor's deputy, with the advice of the Executive Council and under section 2(3) of the **Local Government (Democratic Reform) Act 2003**—

- (a) fix 31 July 2004 as the date on which sections 53, 57 to 60, 62, 63 and 70 of that Act come into operation; and
- (b) fix 20 August 2004 as the date on which section 81 of that Act comes into operation.

Given under my hand and the seal of Victoria on 27 July 2004.

(L.S.) **MARIGOLD SOUTHEY**  
Lieutenant-Governor,  
as the Governor's deputy  
By His Excellency's Command'

**CANDY BROAD**  
Minister for Local Government

**Sustainable Forests (Timber) Act 2004**

**PROCLAMATION OF COMMENCEMENT**

I, Marigold Southey, Lieutenant-Governor of Victoria, as the Governor's deputy, with the advice of the Executive Council and under section 2 of the **Sustainable Forests (Timber) Act 2004**, fix 1 August 2004 as the day on which—

- (a) Division 1 of Part 4, section 95(1) and Schedule 1 of that Act come into operation; and
- (b) Part 3, Divisions 3 and 4 of Part 4, Part 5, Division 1 of Part 6, Part 8, Part 9, section 96, the remaining provisions of Part 11 (except for sections 100(2) and 109) and section 130 of that Act come into operation.

Given under my hand and the seal of Victoria on 27 day of July 2004.

(L.S.) **MARIGOLD SOUTHEY**  
Lieutenant-Governor  
as the Governor's Deputy  
By His Excellency's Command

**JOHN THWAITES**  
Minister for Environment

**Land Act 1958**

**PROCLAMATION OF ROADS**

I, Marigold Southey, Lieutenant-Governor of Victoria, as the Governor's deputy, with the advice of the Executive Council and under section 25(3)(c) of the **Land Act 1958** proclaim as roads the following lands:

**MUNICIPAL DISTRICT OF THE  
TOWONG SHIRE COUNCIL**

**DORCHAP** – The land in the Parish of Dorchap being Crown Allotment 2013 as shown by hatching on plan hereunder. – (GP1152) – (L8-6826).

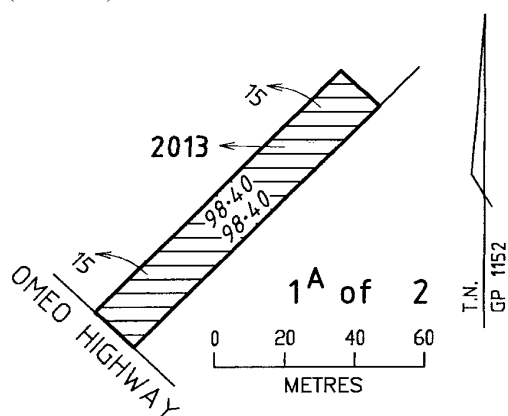

**MUNICIPAL DISTRICT OF THE  
MOIRA SHIRE COUNCIL**

**MUNDOONA** – The land in the Parish of Mundoona being Crown Allotment 2004 as shown by hatching on plan hereunder. – (GP1231A) – (2012554).

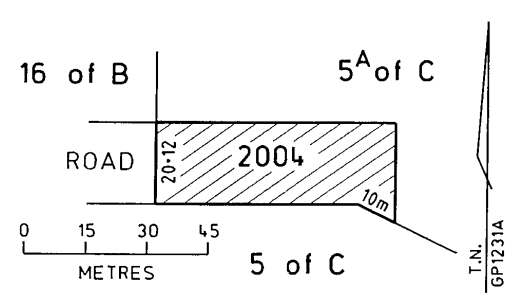

This Proclamation is effective from the date on which it is published in the Government Gazette.

Given under my hand and the seal of  
Victoria on 27 July 2004.

(L.S.)           MARIGOLD SOUTHEY  
Lieutenant-Governor  
as the Governor's Deputy  
By His Excellency's Command

MARY DELAHUNTY, MP  
Minister for Planning

---

**GOVERNMENT AND OUTER BUDGET  
SECTOR AGENCIES NOTICES**



Road Closure

Notice is hereby given that the Greater Bendigo City Council, pursuant to Section 207 of the **Local Government Act 1989**, adopted by Order, a proposal for the closure to through traffic of Hill Street at Bannerman Street.

The Council has resolved that the Order as adopted shall come into operation on 1 September 2004. The location of the road closure is shown on the diagram below.

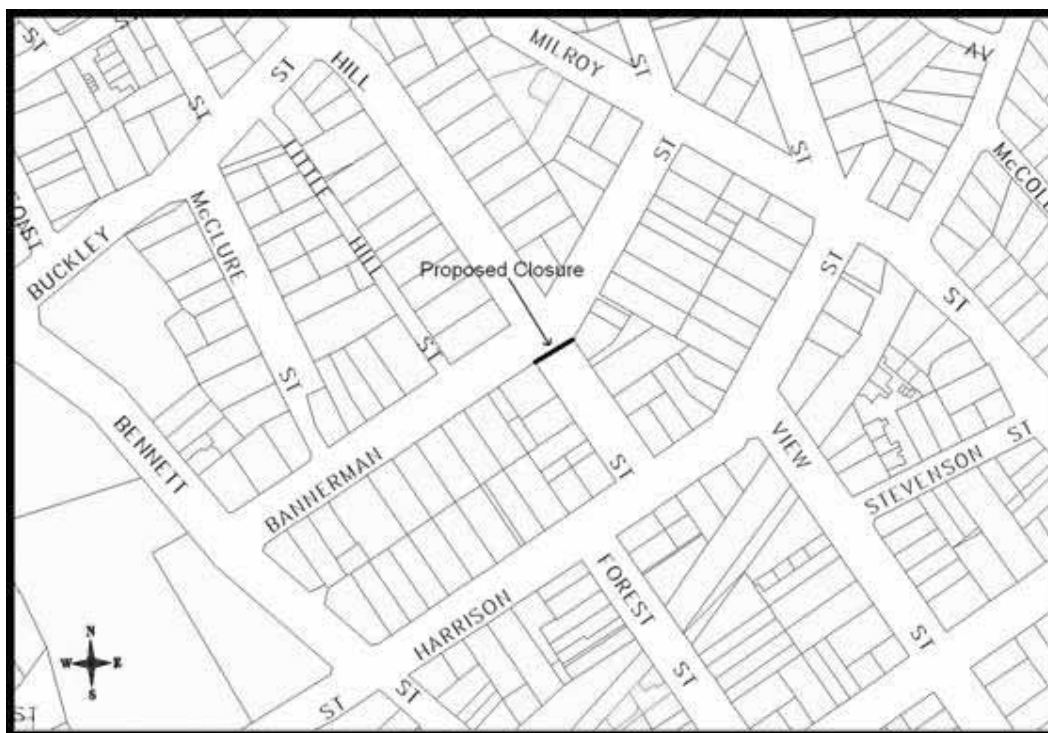

JOHN McLEAN  
Chief Executive Officer



DECLARATION OF A ROAD TO BE  
A PUBLIC HIGHWAY PURSUANT TO SECTION 204(1) OF THE  
LOCAL GOVERNMENT ACT 1989

Notice is hereby given that the section of road bounded by Elizabeth Street, Garfield Street and Shelley Street, Richmond, described on LP 13445 and LP 31784 and as shown hatched on the plan below be declared a public highway pursuant to Section 204(1) of the **Local Government Act 1989**.

The declaration will be operative from the date of publication of this notice.

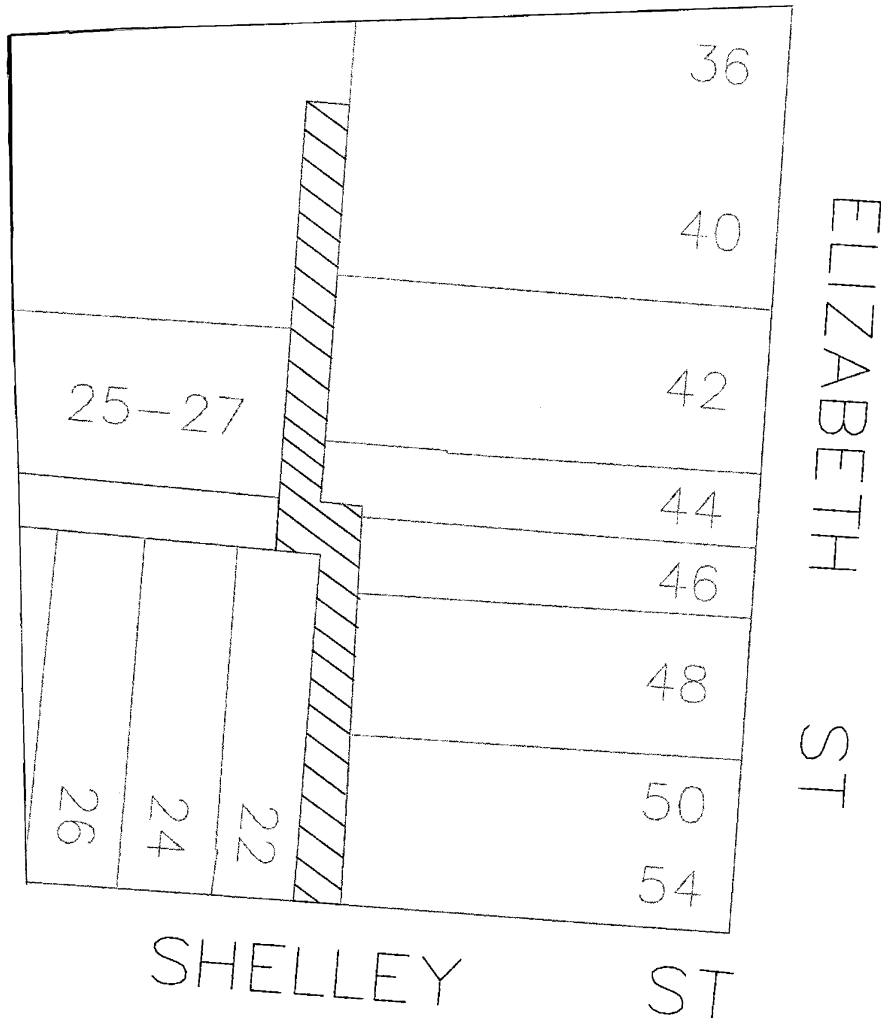

LYDIA WILSON  
Chief Executive Officer





PROPOSED 'ROADS AND COUNCIL LAND (MISCELLANEOUS PARKING AND TRAFFIC MATTERS) LOCAL LAW'  
LOCAL LAW No. 1 OF 2004

Notice is given that the Yarra City Council proposes to make the 'Roads and Council Land (Miscellaneous Parking and Traffic Matters) Local Law, No. 1 of 2004' pursuant to the **Local Government Act 1989** (the Act).

This Local Law is made for the purpose of amending the Roads and Council Land Local Law, No. 2 of 2002 and for:

- providing for the peace, order and good government of the Council;
- promoting a physical and social environment free from hazards to health, in which the residents of the Municipal District can enjoy a quality of life that meets the general expectations of the community;
- preventing and suppressing nuisances which adversely affect the use and enjoyment of recreational reserves;
- minimising and preventing damage to public assets caused by driving and parking vehicles in or on recreational reserves;
- prohibiting, regulating and controlling the parking and driving of vehicles in and on recreational reserves; and
- prohibiting, regulating and controlling the washing of vehicle windscreens on roads.

The general purport of the proposed Local Law is to clarify permitted activities on roads and Council land so as to enhance community amenity and safety.

A copy of the proposed 'Roads and Council Land (Miscellaneous Parking and Traffic Matters) Local Law, No. 1 of 2004' may be obtained from:

- the Richmond Town Hall (333 Bridge Road, Richmond), or the Collingwood Town Hall (140 Hoddle Street, Abbotsford) during normal office hours;
- Council's website: [www.yarracity.vic.gov.au](http://www.yarracity.vic.gov.au)

Any person may make a submission relating to the proposed local law. Submissions are to be received by Council no later than 5.00 pm Tuesday 17 August 2004 and will be considered in accordance with section 223 of the Act. Any person requesting to be heard in support of a written submission is entitled to appear before a meeting of the Finance and Resources Committee on Tuesday 7 September 2004 (6.30 pm Richmond Town Hall, 333 Bridge Road, Richmond) either personally or by a person acting on their behalf.

Written submissions may be lodged at the Council offices in person, posted to the Chief Executive Officer, PO Box 168, Richmond 3121, or emailed to [info@yarracity.vic.gov.au](mailto:info@yarracity.vic.gov.au)

**Privacy Statement**

Any personal information provided in relation to your submission will be used solely by Council for the primary purpose or directly related purpose pertaining to the statutory process concerning the making of the Local Law. Notice is given that your personal information may be published in Council agenda and minute documents.

For further information, contact Chris Reside on 9205 5137 or email [residec@yarracity.vic.gov.au](mailto:residec@yarracity.vic.gov.au).

LYDIA WILSON  
Chief Executive Officer

BANYULE CITY COUNCIL  
Road Discontinuance

Pursuant to Section 206 and Schedule 10, Clause 3 of the **Local Government Act 1989**, Banyule City Council, at its ordinary meeting held on 23 April 2001, having formed the opinion that the section of "road" shown shaded on the plan below is not reasonably required as "road" for public use, resolved to discontinue the section of "road" and sell the land by private treaty to the abutting owner.

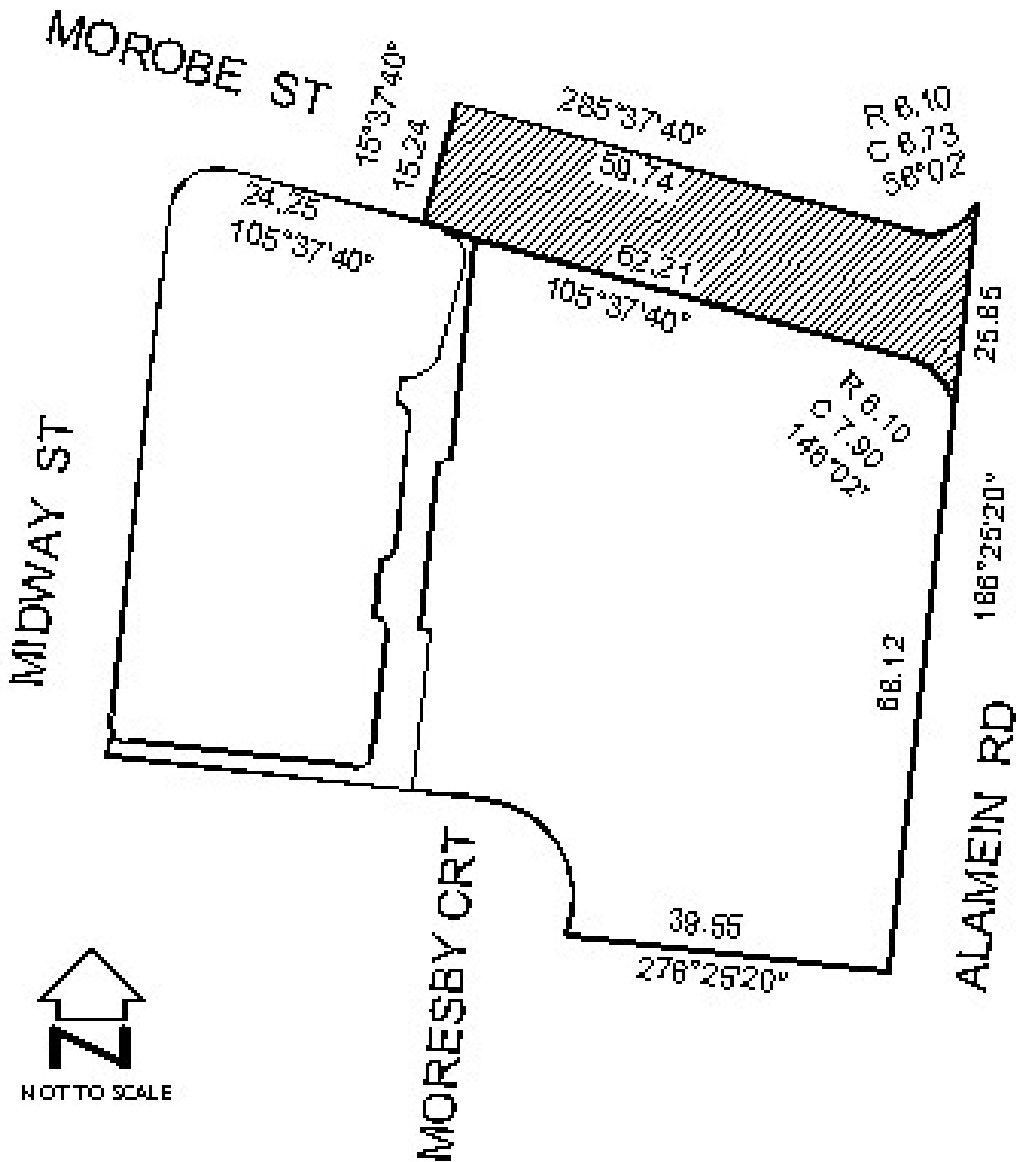

D. OWENS  
Chief Executive Officer



ERRATUM

At its meeting on 19 November 2003 and acting under clause 3 of schedule 10 to the **Local Government Act 1989** Nillumbik Shire Council resolved to discontinue the road shown hatched on the plan below.

The road is to be sold subject to any right, power or interest held by Council in the road in connection with any sewers, drains or pipes under its control that are located in or near the road.

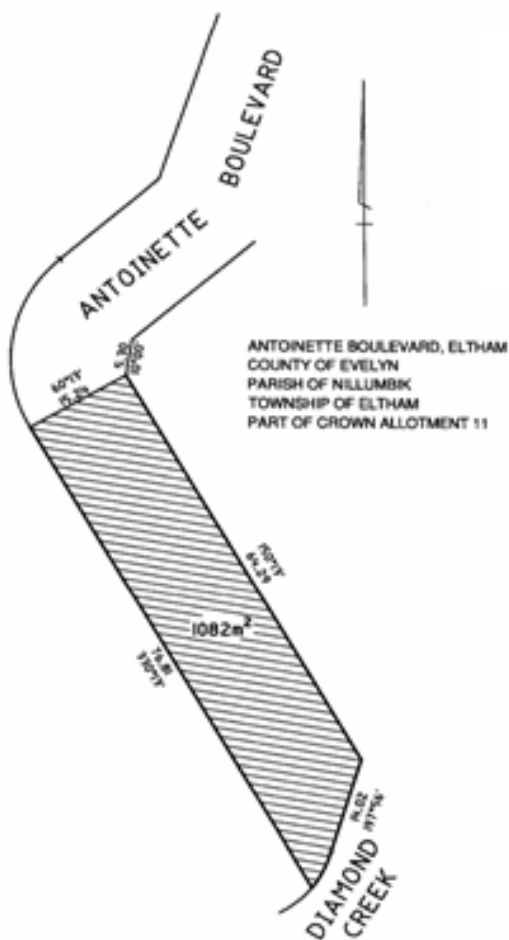

CATHERINE DALE  
Chief Executive Officer

DAREBIN CITY COUNCIL  
Road Discontinuance

Pursuant to section 206 and schedule 10, clause 3 of the **Local Government Act 1989**, the Darebin City Council at its ordinary meeting held on 19 July 2004, formed the opinion that the road at the rear of 18 to part 34 Ashley Street and part 13 to part 35 Olive Street, Reservoir, shown by cross-hatching on the plan below, is not reasonably required as a road for public use and resolved to discontinue the road and to sell the land from the road by private treaty to the abutting property owners.

The road is to be sold subject to the right, power or interest held by Yarra Valley Water and the Darebin City Council in the road in connection with any sewers, drains or pipes under the control of those authorities in or near the road.

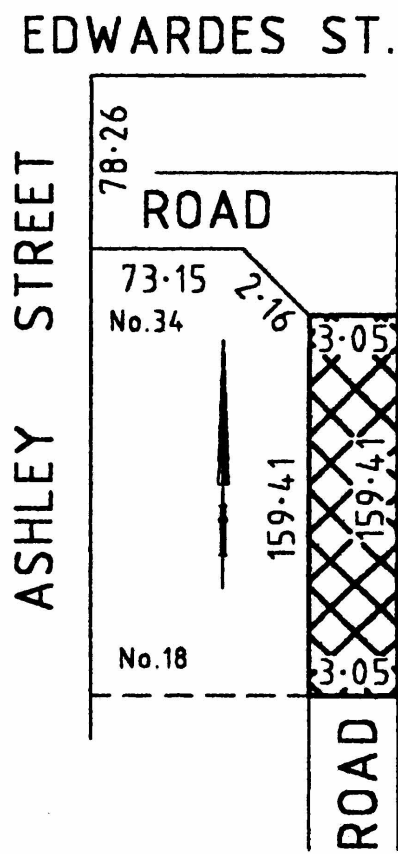

PHILIP SHANAHAN  
Chief Executive Officer

**DAREBIN CITY COUNCIL**  
Road Discontinuance

Pursuant to section 206 and schedule 10, clause 3 of the **Local Government Act 1989**, the Darebin City Council at its ordinary meeting held on 19 July 2004, formed the opinion that the road at the rear of part 17A to 37 Dunstan Street and 28 to 40 Jacka Street, Preston, and shown by hatching on the plan below, is not reasonably required as a road for public use and resolved to discontinue the road and to sell the land from the road by private treaty to the abutting property owners.

The road is to be sold subject to the right, power or interest held by the Darebin City Council in the road in connection with any sewers, drains or pipes under the control of that authority in or near the road.

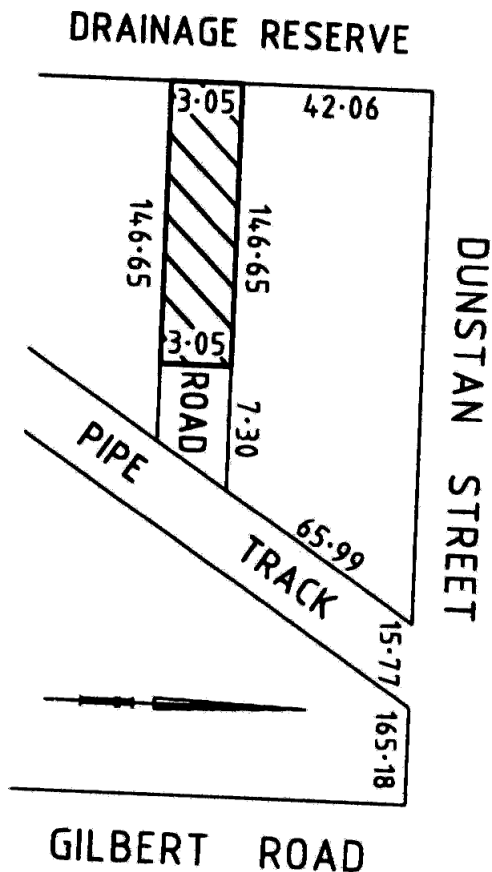

PHILIP SHANAHAN  
Chief Executive Officer

**Planning and Environment Act 1987**  
**BRIMBANK PLANNING SCHEME**

Notice of the Preparation of an Amendment  
to a Planning Scheme  
Amendment C76

This Amendment has been prepared by the Brimbank City Council. The Brimbank City Council is the planning authority for the Amendment.

The land affected by the Amendment is located at 24–32 East Esplanade and 11–27 Victoria Crescent, St Albans.

The Amendment is to rezone the subject land from a Residential 1 to a Business 2 Zone, St Albans, amend Clause 21.08 of the Municipal Strategic Statement and introduce the “St Albans Urban Design Framework, February 2003” as an Incorporated Document.

You may inspect the Amendment and the application, and any documents that support the Amendment and the explanatory report about the Amendment and the application, at the following locations: Brimbank City Council: Keilor Offices, Old Calder Highway, Keilor, or Harvester Customer Service Centre, 301 Hampshire Road, Sunshine 3020; and the Department of Sustainability and Environment, Planning Information Centre, Upper Plaza, Nauru House, 80 Collins Street, Melbourne.

This can be done during office hours and is free of charge.

Any person who may be affected by the Amendment or by the granting of the permit may make a submission to the planning authority.

The closing date for submissions is Friday 27 August 2004. A submission must be sent to: Mr Andrew Gray, Manager Statutory Planning, Brimbank City Council, PO Box 106, Keilor, Victoria 3036.

**Planning and Environment Act 1987**  
**GOLDEN PLAINS PLANNING SCHEME**  
Notice of Amendment  
Amendment C22

The Golden Plains Shire has prepared Amendment C22 to the Golden Plains Planning Scheme. The Amendment has been prepared at the request of Barwon Water.

**Land affected by the Amendment:**

The Amendment applies to a section of land, part of the parcel known as Lot 1 on PS 307324N, Parish of Wabdallah and is located at the western end of Milton Street, Bannockburn. The area in question is landlocked and is located north of the existing Bannockburn Basin site.

**What the Amendment proposes:**

The Amendment proposes to apply the Public Acquisition Overlay to a section of land adjacent to the existing Bannockburn Basin site required for future water supply infrastructure. The Amendment also includes reference to the Public Acquisition Overlay provisions and schedule previously omitted.

**Where you may inspect this Amendment:**

You may inspect this Amendment, any documents that support the Amendment and the explanatory report about the Amendment during office hours and free of charge at the following locations: Department of Sustainability and Environment, Planning Information Centre, Upper Plaza, Nauru House, 80 Collins Street, Melbourne, Victoria 3000; Department of Sustainability and Environment, Geelong Regional Office, 4th Floor, State Government Offices, corner of Little Malop and Fenwick Streets, Geelong, Victoria 3220; Department of Sustainability and Environment, Ballarat Regional Office, 402–406 Mair Street, Ballarat, Victoria 3350; and Golden Plains Shire Council, Bannockburn Customer Service Centre, 2 Pope Street, Bannockburn, Victoria 3331.

Any person who may be affected by the Amendment may make a submission to the planning authority, Golden Plains Shire Council. The closing date for submissions is 30 August 2004. Submissions should be sent to Strategic Planning, Golden Plains Shire, PO Box 111, Bannockburn, Victoria 3331. Enquiries should be directed to Matt Kelleher, Strategic Planner by telephoning (03) 5220 7111 during business hours.

ROD NICHOLLS  
Chief Executive Officer

**Planning and Environment Act 1987****MORELAND PLANNING SCHEME**

## Notice of Preparation of Amendment

## Amendment C41

The Moreland City Council has prepared Amendment C41 to the Moreland Planning Scheme.

The land affected by the Amendment is the primary school campus of the King Khalid College, located at 649–651, 653, 669 & 671 Sydney Road and 33–39, 43, 62 & 64 Ross Street, Coburg.

**The Amendment proposes to:**

- rezone the land owned and/or occupied by the King Khalid Islamic College currently zoned Industrial 3 Zone to the Business 2 Zone;
- apply the Environmental Audit Overlay to 649–651, 669 & 671 Sydney Road, Coburg;
- apply the Incorporated Plan Overlay (IPO4) over the site of College; and
- include the King Khalid College Primary School Campus Incorporated Plan, May 2004, as an incorporated document at Clause 82 of the Moreland Planning Scheme.

You may inspect the Amendment, any documents that support the Amendment and the explanatory report about the Amendment at the following locations: at the office of the planning authority, Moreland City Council, Moreland Civic Centre Planning Counter, 90 Bell Street, Coburg; and at the Department of Sustainability and Environment, Planning Information Centre, Upper Plaza, Nauru House, 80 Collins Street, Melbourne.

This can be done during office hours and is free of charge.

Any person who may be affected by the Amendment may make a submission to the planning authority.

The closing date for submissions is Monday 30 August 2004. A submission must be sent to: Moreland City Council, Strategic Planning Unit, Submission to Amendment C41, Locked Bag 10, Moreland, Vic. 3058.

ROGER COLLINS  
Director City Development

**Planning and Environment Act 1987****NILLUMBİK PLANNING SCHEME**

## Notice of Preparation of Amendment

## Amendment C26

The Nillumbik Shire Council has prepared Amendment C26 to the Nillumbik Planning Scheme. The Amendment is divided into three parts.

The land affected by the Amendment:

- All land currently designated in Environmental Significance Overlays 1, 2, 3 and 4.
- All areas affected are shown on the maps that form part of this Amendment (Amendment C26 Maps 1–14).
- All land designated in Significant Landscape Overlay Schedule 2.

The proposed Amendment:

Changes to Schedule to the Environmental Significance Overlay:

- introduces exemptions for minor buildings and works into Schedule 1 to the Environmental Significance Overlay (ESO);
- adds exemptions for the removal of identified weed species into the Environmental Significance Overlay (SLO) Schedules 1, 2, 3 and 4;
- introduces a permit requirement for fencing into Schedule 4 to the ESO; and
- incorporates the Shire of Nillumbik Environmental Weed List into the schedule to Clause 81.

Application of the Environmental Significance Overlay/Significant Landscape Overlay:

- improves the accuracy of the Environmental Significance Overlay by modifying the application of the Overlay as shown on maps Amendment C26 Sheets 1–14. The proposed modifications:
  - add areas of environmental significance including habitat for rare and endangered species;
  - remove areas where significant residential development has occurred and where there are clearly no environmental benefits to be gained from requiring a planning permit; and
  - realigns the boundary of the ESO to property boundaries to make its application clearer;
- applies the SLO to areas consistent with the Clause 22.12 Neighbourhood Character Policy.

Changes to Schedule 2 to the Significant Landscape Overlay:

- replaces the existing Statement of nature and key elements with a more detailed description that is consistent with Clause 22.12 Neighbourhood Character Policy;
- introduces exemptions for minor buildings and works into Schedule 2 to the Significant Landscape Overlay.

You may inspect the Amendment, any documents that support the Amendment and the explanatory report about the Amendment at the following locations: at the office of the planning authority, Nillumbik Shire Council, Civic Drive, Greensborough; and at the Department of Sustainability and Environment, Planning Information Centre, Upper Plaza, Nauru House, 80 Collins Street, Melbourne.

This can be done during office hours and is free of charge.

Any person who may be affected by the Amendment may make a submission to the planning authority.

The closing date for submissions is 31 August 2004. All submissions must be sent to: Margaret Abbey, Manager of Environment and Strategic Planning, PO Box 476, Greensborough 3088.

CATHERINE DALE  
Chief Executive Officer



**Planning and Environment Act 1987**  
**PORT PHILLIP PLANNING SCHEME**

Notice of the Preparation of an Amendment to  
a Planning Scheme and Notice of an  
Application for Planning Permit

Amendment C41

Application 0791/2003

The land affected by the Amendment is 113 Cecil Street, 122–130 and 132 York Street, 99, 103–107 and 109 Market Street, Browns Lane and Market Place, South Melbourne (former Red Bears site).

The land affected by the application is 113 Cecil Street, 122–130 and 132 York Street, 99, 103–107 and 109 Market Street, Browns Lane and Market Place, South Melbourne (former Red Bears site).



The Amendment proposes to rezone the subject land from a Business 3 Zone to a Business 1 Zone; introduce a new schedule (DDO15) to the Design and Development Overlay and apply the schedule to the subject land; and introduce site specific floor-space limits for shop, office and restricted retail uses into the schedule to the Business 1 Zone.

The application is for a permit to allow for the part demolition of No. 113 Cecil Street and demolition of all other buildings on the land, and the construction of alterations and additions to No. 113 Cecil Street, and a new seven (7) level building plus two (2) basement car parking levels comprising shops, including a supermarket, restricted retail premises, offices, and restaurants and a tavern including the sale and consumption of liquor, associated car parking, and part dispensation from car parking requirements and exceed the preferred maximum building height for the land.

The person who requested the Amendment and the applicant for the permit is SJB Planning Pty Ltd on behalf of the Spotlight group of companies.

You may inspect the Amendment and the application, and any documents that support the Amendment and application, and the explanatory report about the Amendment and application at City of Port Phillip Municipal Offices: South Melbourne Town Hall – Reception, 208–220 Bank Street, South Melbourne, 3205; St Kilda Town Hall – Reception, corner of Carlisle Street and Brighton Road, St Kilda, 3182; St Kilda Municipal Library, Reference Desk, 150 Carlisle Street (opposite Town Hall), St Kilda, 3182; Emerald Hill Library, 159 Bank Street, South Melbourne; Department of Sustainability and Environment, Planning Information Centre, Upper Plaza, Nauru House, 80 Collins Street, Melbourne; and Department of Sustainability and Environment, North-West Regional Office, 499 Ballarat Road, Sunshine.

This can be done during office hours and is free of charge.

The Amendment can also be viewed at the Council's website at [www.portphillip.vic.gov.au/planning\\_scheme\\_amendments\\_currently\\_on\\_exhibition.html](http://www.portphillip.vic.gov.au/planning_scheme_amendments_currently_on_exhibition.html).

Any person who may be affected by the Amendment or by the granting of the permit may make a submission to the planning authority.

The closing date for submissions is 6 September 2004. A submission must be in writing and be sent to: Sue Wilkinson, Manager, Planning and Building, City of Port Phillip, Private Bag No. 3, PO St Kilda, Victoria 3182.

Please note, all submissions will be publicly available.

Ms SUE WILKINSON  
Manager, Planning and Building

Creditors, next-of-kin and others having claims against the estate of any of the undermentioned deceased persons are required to send particulars of their claims to State Trustees Limited, ABN 68 064 593 148, 168 Exhibition Street, Melbourne, Victoria 3000, the personal representative, on or before 6 October 2004 after which date State Trustees Limited may convey or distribute the assets having regard only to the claims of which State Trustees Limited then has notice.

BALLANTYNE, Geoffrey Gordon, late of 15 Kiata Drive, Mildura, retired and who died on 22 April 2004.

CARPENTER, Alwyn Lloyd Price, late of 85 Melbourne Road, Williamstown, Victoria 3016, retired and who died on 3 May 2004.

CLEMENTS, Moira Rose, late of 4 Churchill Street, Kew, Victoria 3101, retired and who died on 2 July 2004.

COSTAR, Norman Leslie, late of Penshurst Nursing Home, Cobb Street, Penshurst, Victoria 3289, retired and who died on 26 May 2004.

CRAIG, Albert James, late of Room 18, The Sacred Heart Hostel, 101 Grey Street, St Kilda, Victoria 3182, and who died on 23 June 2004.

CURTIS, William Luke, late of Corpus Christi Community, 855 Mickleham Road, Greenvale, Victoria 3059, pensioner and who died on 11 June 2004.

DAVIES, Philippe Andrey, late of Flat 11, 70 Carlisle Street, St Kilda, Victoria 3182, retired and who died on 14 May 2004.



- FOGARTY, Thomas Francis, late of Waverley Valley Aged Care, 29–33 Chesterville Road, Glen Waverley, Victoria 3150, pensioner and who died on 18 June 2004.
- GIBBS, Leslie Howard, late of 9 Arkwright Court, Noble Park North, retired and who died on 14 July 2004.
- GRIMA, David Jason, late of 32 Scotia Crescent, Keysborough, printer and who died on 17 April 2004.
- HAMMONDS, Jeffrey Woosley Harvey, late of Unit 69, Morven Manor Retirement Village, 77 Tanti Avenue, Mornington, Victoria 3931, retired and who died on 5 June 2004.
- HURTIG, Elizabeth Agnes, late of 43 Hunt Crescent, Ascot Vale, Victoria 3032, retired and who died on 23 April 2004.
- LACIS, Jazeps, late of Apartment 8, Liela Street, Jelgava, Latvia, labourer and who died on 26 July 1993.
- MELAN, Jozsef, late of 25 Sutherland Street, Coburg, and who died on 6 May 2004.
- OHLENROTT, Mary Helena, late of Brimlea Nursing Home, 21 Railway Parade, Murrumbena, pensioner and who died on 30 January 2004.
- PEARCE, Jack Clive, late of Harold McCracken House, 6 Church Street, Fitzroy North, pensioner and who died on 2 May 2004.
- WATSON, Warren Frances, late of 1/4 Melbourne Street, Murrumbena, retired and who died on 21 July 2004.
- WHITE, Marjorie Elizabeth, late of 1/42 Grosvenor Street, Brighton, retired and who died on 22 May 2004.
- Dated 28 July 2004

LAURIE TAYLOR  
Estate Manager  
State Trustees Limited

Creditors, next-of-kin and others having claims against the estate of any of the undermentioned deceased persons are required to send particulars of their claims to State Trustees Limited, ABN 68 064 593 148, 168 Exhibition Street, Melbourne, Victoria 3000, the personal representative, on or before 30 September 2004 after which date State Trustees Limited may convey or distribute assets having regard only to the claims of which State Trustees Limited then has notice.

- ANDREWS, Mavis, late of Unit 13/63 Frankston–Flinders Road, Frankston, Victoria 3199, retired and who died on 7 July 2004.
- BOKOR, Josef, formerly of 10 Lambert Street, Richmond, but late of Glenhuntly Private Nursing Home, 5 Maroona Road, Glen Huntly, pensioner and who died on 2 June 2004.
- BREWSTER, Charles Henry Alfred, late of Unit 9, 420 Church Road, Templestowe, pensioner and who died on 3 July 2004.
- CHAPMAN, Hazel Jean, late of Bendigo Health Care, Hospice Unit, Anne Caudle Campus, corner of Mercy and Barnard Streets, Bendigo, Victoria 3550, pensioner and who died on 8 May 2004.
- CONIBEER, Sonia Tezza, late of Grace McKellar House, 19–21 Colac Grove, Belmont, Victoria 3216, retired and who died on 13 January 2004.
- HARASYMIW, Anna, late of Ukrainian Hostel, 344 Taylors Road, Delahey, retired and who died on 29 April 2004.
- ILTON, David Canet, late of Dalkeith Hostel, Marie Street, Traralgon, pensioner and who died on 8 May 2004.
- MARTIN, Mary Ruth, formerly of 52 Iluka Avenue, Aspendale 3195, but late of 2/3 Passfield Avenue, Brunswick West, Victoria 3055, retired and who died on 2 April 2004.
- RICHMOND, Donald Gordon, late of Bethlehem Hospital, 476 Kooyong Road, Caulfield, Victoria, pensioner and who died on 11 May 2004.
- SAUNDERS, Iris Paton, late of Glenroy Private Nursing Home, 85–87 Chapman Avenue, Eltham, widow and who died on 16 May 2004.
- SUFFIELD, Audrey Amelia, late of Epping Private Nursing Home, 30 Epping Road, Epping, pensioner and who died on 6 April 2004.
- TODOROVSKI, Svetozar, formerly of 4/3 Geddes Street, Ascot Vale, but late of 42 Lyle Street, Brunswick, retired and who died on 11 July 2004.
- WEBBER, Leslie Ronald, late of Kyneton Hospital, Simpson Street, Kyneton, pensioner and who died on 24 May 2004.
- Dated 22 July 2004.

LAURIE TAYLOR  
Estate Manager  
State Trustees Limited

## STATE TRUSTEES LIMITED

ACN 064 593 148

## Section 79

Notice is hereby given that State Trustees Limited, ACN 064 593 148, intends administering the estate of:-

LEON PATRICK FISH, late of Mulvra Place, 231 Dowling Street, Wendouree, Victoria, pensioner, deceased, who died on 25 June 2004 leaving a Will dated 17 March 1981.

HUGH SELBY PULLEN, late of Unit 3, 1 Campbell Road, Briar Hill, Victoria, retired, deceased, who died on 6 October 2001 leaving a Will dated 10 July 1986.

WILLIAM ARTHUR STEDWELL, late of 6 Gillingham Street, Preston, Victoria, retired, deceased, intestate, who died on 20 November 2002.

Creditors, next-of-kin and others having claims against the abovementioned estates are required pursuant to Section 33 of the **Trustee Act 1958** to send particulars of their claims against the abovementioned estates to State Trustees Limited, 168 Exhibition Street, Melbourne, Victoria on or before 30 September 2004 after which date State Trustees Limited, ACN 064 593 148, may convey or distribute the assets of the abovementioned estates having regard only to the claims of which it then has notice.

Department of Treasury and Finance

SALE OF CROWN LAND  
BY PUBLIC TENDER

**Tenders Close:** Wednesday 25 August 2004 at 2.00 p.m.

**Reference:** 2002/01643.

**Address of Property:** 69-79 Lorimer Street, Southbank.

**Crown Description:** Crown Allotment 2033, Parish of Melbourne South.

**Terms of Sale:** 1% on tender lodgement, 9% upon acceptance of tender, balance 90 days.

**Area:** 1.023 ha.

**Officer Co-ordinating Sale:** Militsa Toskovska, Victorian Government Property Group, Department of Treasury and Finance, 5/1 Treasury Place, Melbourne, Vic. 3002.

**Selling Agent:** Gross Waddell, Level 6, 180 Flinders Street, Melbourne 3000.

JOHN LENDERS MLC  
Minister for Finance

**Catchment and Land Protection Act 1994**

The North East Regional Catchment Strategy has been accredited by the Australian and Victorian Governments against the national criteria agreed by the Natural Resource Management Ministerial Council as of 21 June 2004, and signed by David Kemp, Minister for the Environment and Heritage; Warren Truss, Minister for Agriculture, Fisheries and Forestry; John Thwaites, Deputy Premier of Victoria and Victorian Minister for Environment, Water, and Victorian Communities; and Bob Cameron, Victorian Minister for Agriculture.

**Catchment and Land Protection Act 1994**

The West Gippsland Regional Catchment Strategy has been accredited by the Australian and Victorian Governments against the national criteria agreed by the Natural Resource Management Ministerial Council as of 21 June 2004, and signed by David Kemp, Minister for the Environment and Heritage; Warren Truss, Minister for Agriculture, Fisheries and Forestry; John Thwaites, Deputy Premier of Victoria and Victorian Minister for Environment, Water, and Victorian Communities; and Bob Cameron, Victorian Minister for Agriculture.

**Children's Services Act 1996**

## Notice of Exemption

Under Section 6 of the **Children's Services Act 1996** (the Act), the Minister for Community Services hereby declares that the proprietor of the Strathdale Community Centre – Licence ID 9896 (the service) is exempt from the qualified staff members requirement as set out in regulation 24 of the Children's Services Regulations 1998 (the Regulations).

The exemption is granted subject to the conditions that the proprietor must ensure that:

- whenever children are being cared for or educated by the service, the number of staff members as set out in regulation 24 are caring for or educating the children.

This exemption remains in force until 31 December 2004.

Declared at Melbourne on 15 July 2004

HON SHERRYL GARBUTT MP  
Minister For Community Services

**Co-operatives Act 1996**

BOORT COMMUNITY CENTRE  
CO-OPERATIVE LIMITED

LOCH SPORT RSL CO-OPERATIVE  
LIMITED

McKINNON SC GYM PROJECT  
CO-OPERATIVE LTD

OMEIO FINE FIBRES CO-OPERATIVE LTD

Notice is hereby given in pursuance of Section 316(1) of the **Co-operatives Act 1996** and Section 601AB(3)(e) of the **Corporations Act 2001** that, at the expiration of two months from the date hereof, the names of the aforementioned co-operatives will, unless cause is shown to the contrary, be struck off the register and the co-operatives will be dissolved.

Dated at Melbourne, 22 July 2004

ANDREW LEVENS  
Assistant Registrar of Co-operatives

**Environment Protection Act 1970**

Act No. 8056/1970

INDUSTRIAL WASTE MANAGEMENT  
POLICY (PRESCRIBED INDUSTRIAL  
WASTE) 2000

No. S 183 December 2000

Prescribed Industrial Waste Classification

1. For the purpose of clause 11(1) and in accordance with Schedule 1 of the Industrial Waste Management Policy (Prescribed Industrial Waste) the Environment Protection Authority hereby classifies grease interceptor trap effluent as having currently available<sup>1</sup> opportunities for reuse and recycling in the State of Victoria.
2. The classification applies to grease interceptor trap effluent as prescribed in Part B of Schedule 1 of the Environment Protection (Prescribed Waste) Regulations 1998.
3. For the purposes of this classification, grease interceptor trap effluent refers to the food, grease and solids captured by a grease interceptor before discharge to sewer, or any residual solids derived from the treatment of this waste.

4. This classification will come into effect upon publication in the Government Gazette.

<sup>1</sup>Currently available: The prescribed industrial waste has potential for reuse, recycling or recovery of energy and such reuse, recycling or recovery of energy is practicable. This means that the facilities required to realise this potential are available in the State of Victoria, or elsewhere in Australia in a location practicably accessible.

**Essential Services Commission Act 2001**

## NOTICE OF DETERMINATION

The Essential Services Commission ("Commission") gives notice under section 35(2) of the **Essential Services Commission Act 2001** (Vic) that it has, pursuant to section 68(8)(b)(ii) of the **Electricity Industry Act 2000** (Vic), made a determination in respect of the proposed acquisition of the electricity generation businesses of Edison Mission Energy Australia Limited (EME) – (1) Loy Yang B and (2) 60 percent of Valley Power Generating facilities by a consortium in which International Power plc (IP) is the principal partner.

The Commission has determined that it is satisfied that the Australian Competition and Consumer Commission ("ACCC") has considered the proposed acquisition of EME – (1) Loy Yang B and (2) 60 percent of Valley Power by the consortium and that the ACCC has notified IP that it does not intend to take action in relation to the acquisition under section 50 of the **Trade Practices Act 1974** (Cwlth).

The effect of this determination is that the proposed acquisition of EME – (1) Loy Yang B and (2) 60 percent of Valley Power by the consortium would not represent a prohibited interest held by IP under section 68 of the **Electricity Industry Act 2000**.

The ACCC has notified IP that its agreement not to take action under section 50 of the TPA in regard to the proposed acquisition of EME is subject to the ACCC's acceptance of certain undertakings at section 87B of the TPA by IP. The Commission has therefore noted in correspondence to IP that, pursuant to section 75(4) of the **Electricity Industry Act 2000**, the Commission may revoke or vary the

determination by notice in writing served on IP. The Commission may exercise this power if circumstances change such that the information on which the determination was based is no longer considered sufficient by the Commission.

The determination takes effect on and from the date on which this notice is published in the Government Gazette.

A copy of the determination is available on the Commission's website located at <http://www.esc.vic.gov.au> or a copy can be obtained by calling Mr Richard Bunting on (03) 9651 0222.

JOHN C. TAMBLYN  
Chairperson

#### Essential Services Commission Act 2001

##### NOTICE OF DETERMINATION

The Essential Services Commission (Commission) gives notice under section 35(2) of the **Essential Services Commission Act 2001** (Vic) that it has, pursuant to section 68(8)(b)(ii) of the **Electricity Industry Act 2000** (Vic), made a determination in respect of the proposed acquisition of a group of companies of which TXU Australia Group Pty Ltd (ACN 104 896 497) (TXUAG) is the Australian holding company by SP Energy Pty Ltd (ACN 104 896 497) (SPE), a subsidiary of Singapore Power Limited, (Acquisition). TXUAG is the holding company for TXU's Australian operations.

The Commission has determined that it is satisfied that the Australian Competition and Consumer Commission (ACCC) has considered the Acquisition. The Commission notes that the ACCC has advised SPE that the ACCC has accepted court-enforceable undertakings pursuant to section 87B of the **Trade Practices Act 1974** (TPA) and that the ACCC does not propose to intervene in the proposed acquisition pursuant to section 50 of the TPA.

The effect of this determination is that the Acquisition would not represent a prohibited interest under section 68 of the **Electricity Industry Act 2000**.

The determination takes effect on and from the date on which this notice is published in the Government Gazette.

A copy of the determination is available on the Commission's website located at <http://www.esc.vic.gov.au> or a copy can be obtained by calling Mr Richard Bunting on (03) 9651 0222.

JOHN C. TAMBLYN  
Chairperson

#### Livestock Disease Control Act 1994

##### APPOINTMENT OF INSPECTORS

I, John William Galvin, Manager Animal Health Operations in the Department of Primary Industries, pursuant to the powers, duties and functions given to me by a delegation under section 103 of the **Livestock Disease Control Act 1994** and of my respective powers to appoint inspectors under section 108 of the **Livestock Disease Control Act 1994**, hereby appoint the following person, who holds a position under the provisions of the **Public Sector Management and Employment Act 1998**, as an inspector for the purposes of all of the provisions of the **Livestock Disease Control Act 1994** in respect of fish.

Name of person	Position number
Mehdi Doroudi	9330

Dated 14 July 2004

JOHN WILLIAM GALVIN  
Manager  
Animal Health Operations

#### Livestock Disease Control Act 1994

##### APPOINTMENT OF INSPECTORS

I, John William Galvin, Manager Animal Health Operations in the Department of Primary Industries, pursuant to the powers, duties and functions given to me by a delegation under section 103 of the **Livestock Disease Control Act 1994** and of my respective powers to appoint inspectors under section 108 of the **Livestock Disease Control Act 1994**, hereby appoint the following persons, who hold positions under the provisions of the **Public Sector Management and Employment Act 1998**, as inspectors for the purposes of all of the provisions of the **Livestock Disease Control Act 1994** in respect of all livestock.

Name of person	Position number
George Mason Downing	010444
Benjamin Anthony Fahy	10439
John Douglas Ryan	437887
Allan Walter Semmler	508807

Dated 14 July 2004

JOHN WILLIAM GALVIN  
Manager  
Animal Health Operations

**Agricultural and Veterinary Chemicals  
(Control of Use) Act 1992**

APPOINTMENT OF  
AUTHORISED OFFICERS

I, John William Galvin, Manager Animal Health Operations in the Department of Primary Industries, pursuant to the powers, duties and functions given to me by a delegation under section 74 of the **Agricultural and Veterinary Chemicals (Control of Use) Act 1992** and of my respective powers to appoint authorised officers under section 53 of the **Agricultural and Veterinary Chemicals (Control of Use) Act 1992**, hereby appoint the following persons employed in the Public Service, as authorised officers for the purposes of all of the provisions of the **Agricultural and Veterinary Chemicals (Control of Use) Act 1992** and any Regulation or Order made under this Act.

Name of person	Position number
Mehdi Doroudi	9330
George Mason Downing	010444
Benjamin Anthony Fahy	10439
John Douglas Ryan	437887
Allan Walter Semmler	508807

Dated 14 July 2004

JOHN WILLIAM GALVIN  
Manager  
Animal Health Operations

**Prevention of Cruelty to Animals Act 1986**  
APPROVAL OF INSPECTORS

I, Peter John Bailey, Director Quality Assurance in the Department of Primary Industries, pursuant to the powers, duties and functions given to me by a delegation under section 38 of the **Prevention of Cruelty to**

**Animals Act 1986** and of my respective powers to approve inspectors under section 18 of the **Prevention of Cruelty to Animals Act 1986**, hereby approve the following persons, who are inspectors of livestock under the provisions of the **Livestock Disease Control Act 1994**, as inspectors for the purposes of Part 2 of the **Prevention of Cruelty to Animals Act 1986**. These approvals remain in force until 30 June 2006.

Name of person	Position number
Mehdi Doroudi	9330
George Mason Downing	010444
Benjamin Anthony Fahy	10439
John Douglas Ryan	437887
Allan Walter Semmler	508807

Dated 15 July 2004

PETER JOHN BAILEY  
Director Quality Assurance

**Local Government Act 1989**

NOTICE UNDER SECTION 219C  
**LOCAL GOVERNMENT ACT 1989** OF  
FIRST COUNCIL ELECTORAL  
REPRESENTATION REVIEWS

I, Candy Broad, Minister for Local Government, give notice under section 219C for the purposes of section 219C(1)(a) of the **Local Government Act 1989** that reviews for:

Brimbank City Council; Central Goldfields Shire Council; Glen Eira City Council; Hindmarsh Shire Council; Horsham Rural City Council; Loddon Shire Council; Maribyrnong City Council; Mildura Rural City Council; Monash City Council; Mount Alexander Shire Council; West Wimmera Shire Council; and Yariambiack Shire Council

shall take place in accordance with the following timeframes:

- the earliest date that the reviews may commence is 1 September 2004;
- the date by which each Council must appoint a reviewer is 6 September 2004; and
- the date by which the final report must be submitted to the Minister for Local Government is 31 March 2005.

CANDY BROAD, MLC  
Minister for Local Government





Land Acquisition and Compensation Act 1986

FORM 7

Section 21  
Regulation 16

Notice of Acquisition

Compulsory Acquisition of Interest in Land

Casey City Council declares that by this notice it acquires the following interest in the land described as R3 on Plan of Subdivision 524747 being part of the land in Certificate of Title Volume 6120 Folio 869 and known as 71 Craig Road, Devon Meadows, Victoria 3977:

Estate in fee simple.

Published with the authority of the Casey City Council.

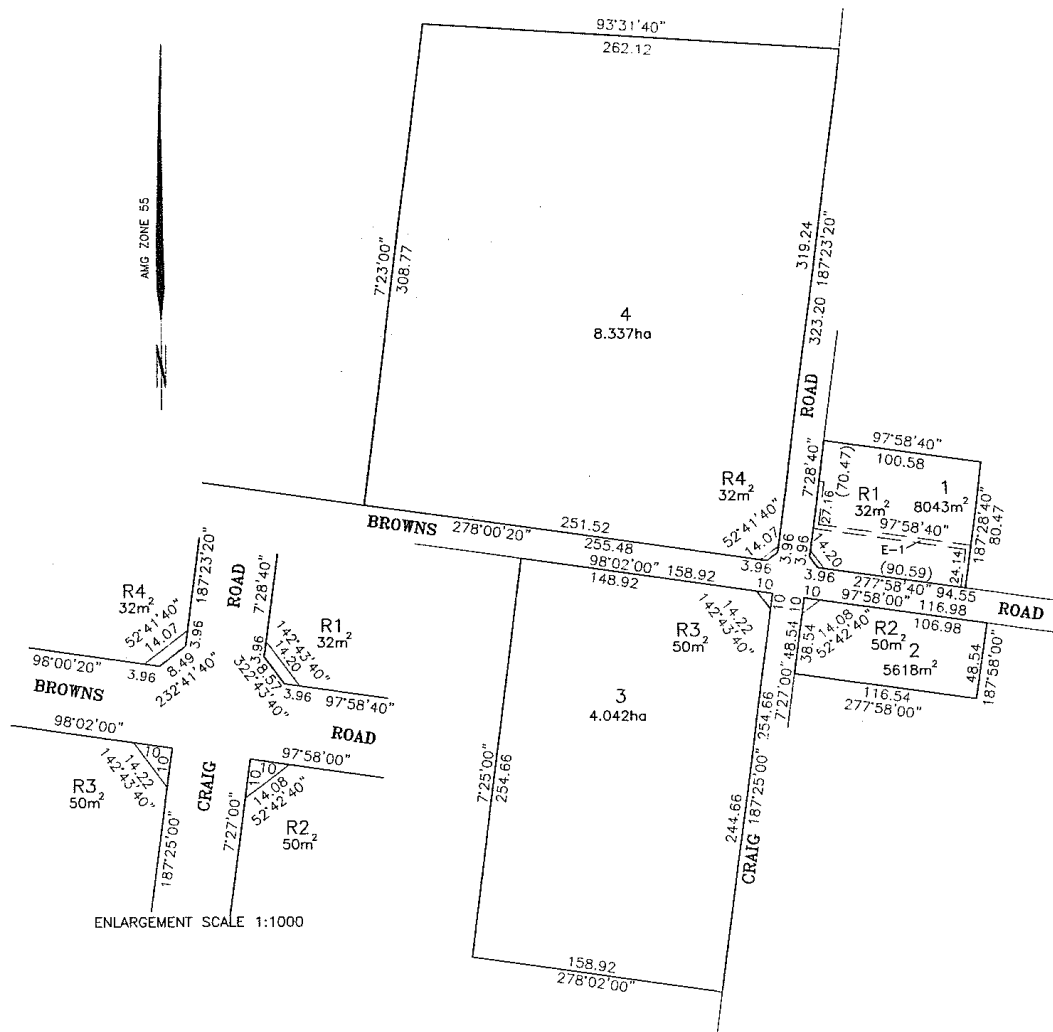

Dated 29 July 2004

For and of behalf of the  
Casey City Council





The Knox City Council thinks that the land is suitable for the provision of a permanent road, pedestrian and bicycle access from Stud Road to Stamford Park, Rowville.

The land:

- is reserved for a public purpose under the Knox Planning Scheme; or
- is not exempted from the reservation requirements under section 5 of the **Land Acquisition and Compensation Act 1986**; or
- is not in a class of land exempted from reservation under section 5 of the **Land Acquisition and Compensation Act 1986**; or
- has not been certified by the Governor in Council as land which need not be reserved; or
- is not special project land under section 201I(3) of the **Planning and Environment Act 1987**.

At the present time it is expected that the Knox City Council may require possession of the land on the date that is two months and seven days from the date this Notice of Intention to Acquire is served. This date may change.

The Knox City Council requires you to provide it with information about the following:

1. The name of any other person who has, or you think may have, an interest in the land. (Such a person might be a tenant or a mortgagee or a person to whom you have agreed to sell the land.)
2. If you have a current building permit or approval or a planning permit concerning the land.
3. If you have sold or let or in any other way dealt with the land or were intending to deal with the land immediately before you received this notice.
4. If you know of any other person proposing to do any of those things mentioned in paragraph 3.
5. Any other matters of which you are aware which will help the Knox City Council to work out what compensation you should receive for the land. (This information may include details of any mortgage, lease or other arrangement affecting the land. If you claim financial loss, please provide financial documents and other records to substantiate all losses. All documents provided will be treated in confidence).

Dated 19 July 2004

For and on behalf of  
the Knox City Council:  
Mr GRAEME EMONSON  
Chief Executive Officer

---

### **Private Agents Act 1966**

#### **NOTICE OF RECEIPT OF APPLICATIONS FOR LICENCES UNDER THE PROVISIONS OF THE PRIVATE AGENTS ACT 1966**

I, the undersigned, being the Registrar of the Magistrates' Court at Melbourne hereby give notice that applications as under have been lodged for hearing by the said Court on the date specified.

Any person desiring to object to any of such applications must—

- (a) lodge with me a notice in the prescribed form of his objection and of the grounds thereof;
- (b) cause a copy of such notice to be served personally or by post upon the applicant at least three days before the hearing of the application; and
- (c) send or deliver
  - (i) where the objection is not made by the officer in charge of the police district in which the Court is situated — a copy of the notice to such officer; and
  - (ii) where the objection is not made by the Registrar or Deputy Registrar — a copy to the Registrar.

<i>Full name of Applicant or in the case of a Firm or Corporation, of the Nominee</i>	<i>Place of Abode of Applicant or Nominee</i>	<i>Name of Firm or Corporation</i>	<i>Address for Registration</i>	<i>Type of Licence</i>
Kathryn Mary Macdonald	75 Grange Road, Caulfield East 3145	Action Mercantile P/L	Level 2, 10 Queens Road, Melbourne 3004	Commercial Sub-Agents Licence
Christiina Jovanoska	25 Davies Street, Newport 3015	Receivables Management Ltd	363 King Street, Melbourne 3000	Commercial Sub-Agents Licence
Scott Riordan	14 Hillview Rise, Gisborne South	Receivables Management Ltd	363 King Street, Melbourne 3000	Commercial Sub-Agents Licence
Donna Kristine Smith	14 Barton Street, West Footscray 3012	Reliance Recoveries	Suite 304, 22 St Kilda Road, St Kilda 3182	Commercial Agents Licence

Dated at Melbourne, 27 July 2004

GRAEME J. HORSBURGH  
Principal Registrar  
Magistrates' Court of Victoria

**Planning and Environment Act 1987**  
**EAST GIPPSLAND PLANNING SCHEME**  
 Notice of Approval of Amendment  
 Amendment C29

The Minister for Planning has approved Amendment C29 to the East Gippsland Planning Scheme.

The Amendment comes into operation on the date this notice is published in the Government Gazette.

The Amendment rezones land at the River Hill Motel site at 45–47 Main Street (including 48 Macleod Street), Bairnsdale, Certificate of Titles Vol. 9562 Folio 794, Vol. 8041 Folio 878 and Vol. 8978 Folio 649 from Business 1 Zone to Public Use Zone 7 – Other Public Use.

A copy of the Amendment can be inspected, free of charge, during office hours, at the Department of Sustainability and Environment, Planning Information Centre, Upper Plaza, Nauru House, 80 Collins Street, Melbourne, and at the offices of the East Gippsland Shire Council, 273 Main Street, Bairnsdale.

PAUL JEROME  
 Deputy Secretary  
 Built Environment  
 Department of Sustainability  
 and Environment

**Planning and Environment Act 1987**  
**LA TROBE PLANNING SCHEME**  
 Notice of Approval of Amendment  
 Amendment C31

The Minister for Planning has approved Amendment C31 to the La Trobe Planning Scheme.

The Amendment comes into operation on the date this notice is published in the Government Gazette.

The Amendment:

- reconfigures the break up of the planning scheme maps and introduces a new index and map numbering system;
- alters all the local planning provisions to change references to 'La Trobe' to 'Latrobe' and references to 'La Trobe Shire' to 'Latrobe City'.

A copy of the Amendment can be inspected, free of charge, during office hours, at the Department of Sustainability and Environment, Planning Information Centre, Upper Plaza,

Nauru House, 80 Collins Street, Melbourne, and at the offices of the Latrobe City Council, 34–38 Kay Street, Traralgon.

PAUL JEROME  
 Deputy Secretary  
 Built Environment  
 Department of Sustainability  
 and Environment

**Planning and Environment Act 1987**  
**MAROONDAH PLANNING SCHEME**  
 Notice of Approval of Amendment  
 Amendment C34

The Minister for Planning has approved Amendment C34 to the Maroondah Planning Scheme.

The Amendment comes into operation on the date this notice is published in the Government Gazette.

The Amendment introduces new Schedules 3 and 4 to Clause 42.03 (Significant Landscape Overlay), generally to require a permit to remove any tree located beyond three metres of a dwelling on land situated inside the Urban Growth Boundary and formerly affected by the SLO1 and SLO2.

The Amendment also re-instates former Clause 22.12, Ringwood town centre development policy, as Clause 22.15 and makes minor consequential changes within Clauses 21.04, 21.09 and Schedule 2 to Clause 43.04.

The Amendment also re-instates reference to Map 4IPO in the Schedule to Clauses 61.01 – 61.04 (inclusive).

A copy of the Amendment can be inspected, free of charge, during office hours, at the Department of Sustainability and Environment, Planning Information Centre, Upper Plaza, Nauru House, 80 Collins Street, Melbourne, and at the offices of the Maroondah City Council Customer Service Centres: Ringwood Civic Centre, Braeside Avenue, Ringwood; Level 2, Shop G104, Eastland Shopping Centre, Ringwood; Civic Square Customer Service Centre, Civic Square, Croydon; and Main Street Customer Service Centre, 50 Main Street, Croydon.

PAUL JEROME  
 Deputy Secretary  
 Built Environment  
 Department of Sustainability  
 and Environment

**Planning and Environment Act 1987**

## MELTON PLANNING SCHEME

## Notice of Approval of Amendment

## Amendment C27

The Minister for Planning has approved Amendment C27 to the Melton Planning Scheme.

The Amendment comes into operation on the date this notice is published in the Government Gazette.

The Amendment rezones land at 511–531 Taylors Road, Burnside from Rural Zone to Residential 1 Zone, deletes Development Plan Overlay Schedule 1 (DPO1) from the site and introduces a new Development Plan Overlay Schedule 8 (DPO8) to the whole of the land.

A copy of the Amendment can be inspected, free of charge, during office hours, at the Department of Sustainability and Environment, Planning Information Centre, Upper Plaza, Nauru House, 80 Collins Street, Melbourne, and at the offices of the Melton Shire Council, 232 High Street, Melton.

PAUL JEROME  
Deputy Secretary  
Built Environment  
Department of Sustainability  
and Environment

**Planning and Environment Act 1987**

## NORTHERN GRAMPIANS

## PLANNING SCHEME

## Notice of Approval of Amendment

## Amendment C8

The Minister for Planning has approved Amendment C8 to the Northern Grampians Planning Scheme.

The Amendment comes into operation on the date this notice is published in the Government Gazette.

The Amendment rezones land fronting Western Highway, Stawell (part lot S3 PS 319373) from Residential 1 Zone to Business 4 Zone.

A copy of the Amendment can be inspected, free of charge, during office hours, at the Department of Sustainability and Environment, Planning Information Centre, Upper Plaza, Nauru House, 80 Collins Street, Melbourne, and at the offices of the Northern Grampians Shire Council.

PAUL JEROME  
Deputy Secretary  
Built Environment  
Department of Sustainability  
and Environment

**Planning and Environment Act 1987**

## STONNINGTON PLANNING SCHEME

## Notice of Approval of Amendment

## Amendment C5 Part 1

The Minister for Planning has approved Amendment C5 Part 1 to the Stonnington Planning Scheme.

The Amendment comes into operation on the date this notice is published in the Government Gazette.

The Amendment:

- deletes properties that have been assessed as not having heritage significance from the Heritage Overlay Maps and the Schedule to Clause 43.01;
- applies permanent heritage controls over a number of properties that were subject to interim protection and changes the Schedule to Clause 43.01 to more clearly describe the Heritage Places for these properties.

A copy of the Amendment can be inspected, free of charge, during office hours, at the Department of Sustainability and Environment, Planning Information Centre, Upper Plaza, Nauru House, 80 Collins Street, Melbourne, and at the offices of the Stonnington City Council, corner of Greville and Chapel Streets, Prahran.

PAUL JEROME  
Deputy Secretary  
Built Environment  
Department of Sustainability  
and Environment

**Planning and Environment Act 1987**

**YARRA RANGES PLANNING SCHEME**

Notice of Approval of Amendment

Amendment C16 Part 1

The Minister for Planning has approved Amendment C16 Part 1 to the Yarra Ranges Planning Scheme.

The Amendment comes into operation on the date this notice is published in the Government Gazette.

The Amendment applies the Heritage Overlay and its associated Schedule to 260 heritage places.

A copy of the Amendment can be inspected, free of charge, during office hours, at the Department of Sustainability and Environment, Planning Information Centre, Upper Plaza, Nauru House, 80 Collins Street, Melbourne, and at the offices of the Yarra Ranges Shire Council, Anderson Street, Lilydale.

PAUL JEROME  
Deputy Secretary  
Built Environment  
Department of Sustainability  
and Environment

---

**Planning and Environment Act 1987**

**MACEDON RANGES PLANNING SCHEME**

Notice of Lapsing of Amendment

Amendment C24

The Macedon Ranges Shire Council has resolved to abandon Amendment C24 to the Macedon Ranges Planning Scheme.

The Amendment proposed to rezone the land from an Industrial 1 Zone to a Mixed Use Zone (MUZ). The existing Environmental Significance Overlay (ESO4) would have been retained on the site.

The Amendment lapsed on 28 June 2004.

PAUL JEROME  
Deputy Secretary  
Built Environment  
Department of Sustainability  
and Environment

---

**ORDERS IN COUNCIL**

**Crown Land (Reserves) Act 1978**  
**QUEENSBRIDGE SQUARE RESERVATION**  
 Order in Council

The Lieutenant-Governor as the Governor's deputy, with the advice of the Executive Council, under Section 4(1) of the **Crown Land (Reserves) Act 1978** temporarily reserves the following Crown land which in his opinion is required for the purpose mentioned:-

**MUNICIPAL DISTRICT OF THE MELBOURNE CITY COUNCIL**

**SOUTH MELBOURNE** - Public Recreation, Stratum of Crown land being Crown Allotment 2029, City of South Melbourne, Parish of Melbourne South as shown on Original Plan No. 121921 lodged in the Central Plan Office of the Department of Sustainability and Environment. (2013818)

This Order is effective from the date on which it is published in the Government Gazette.

Dated 27 July 2004

Responsible Minister  
**MARY DELAHUNTY**  
 Minister for Planning

**DIANE CASEY**  
 Clerk of the Executive Council

**Crown Land (Reserves) Act 1978**  
**NOTICE OF INTENTION TO REVOKE TEMPORARY RESERVATIONS**

The Lieutenant-Governor as the Governor's deputy, with the advice of the Executive Council, under section 10 of the **Crown Land (Reserves) Act 1978** gives notice of intention to revoke the following temporary reservations:

**SCARSDALE** - The temporary reservation by Order in Council of 14 February 1882 of an area of 8094 square metres more or less, of land in Section 50, Parish of Scarsdale as a site for conservation of Water. - (0513733).

**WARRACKNABEAL** - The temporary reservation by Order in Council of 7 September 1903 of an area of 6.66 hectares of land in Section 27, Township of Warracknabeal, Parish of Werrigar as a site for Public Recreation, so far

only as the portion containing 1127 square metres being Crown Allotment 2001, Township of Warracknabeal as indicated by hatching on plan hereunder. - (GP1557) - (Rs 02154).

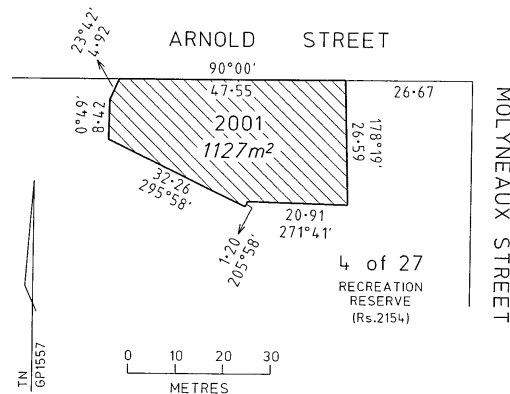

**WILL-WILL-ROOK** - The temporary reservation by Order in Council of 20 May 1997 of an area of 687 square metres of land being Crown Allotment 3F, Parish of Will-will-rook as a site for Cemetery purposes, so far only as the portion containing 562 square metres being Crown Allotment 2003, Parish of Will-will-rook as indicated by hatching on plan hereunder. - (GP1385) - (Rs 8641).

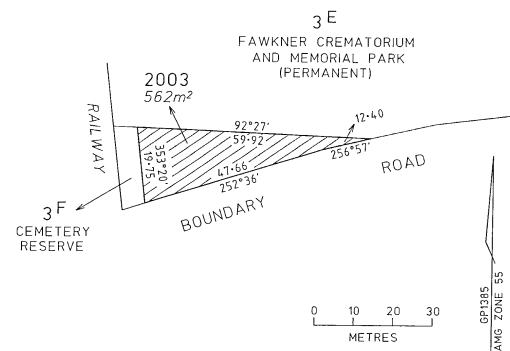

This Order is effective from the date on which it is published in the Government Gazette.

Dated 27 July 2004  
 Responsible Minister  
**MARY DELAHUNTY**  
 Minister for Planning

**DIANE CASEY**  
 Clerk of the Executive Council



**Crown Land (Reserves) Act 1978**  
**REVOCATION OF TEMPORARY**  
**RESERVATIONS**

The Lieutenant-Governor as the Governor's deputy, with the advice of the Executive Council, under section 10 of the **Crown Land (Reserves) Act 1978** revokes the following temporary reservations:

**BARRABOOL** – The temporary reservation by Order in Council of 25 May 1999 of a combined area of 1867 square metres of land being Crown Allotments 3B, 3C and 3E, Section 25, Parish of Barrabool as a site for Public Purposes (Day Program Facility), so far only as the portions containing 1286 square metres being Crown Allotments 3B and 3E, Section 25, Parish of Barrabool. – (2006597).

**KEELBUNDORA** – The temporary reservation by Order in Council of 14 March 1973 of an area of 8.324 hectares of land in the Parish of Keelbundora as a site for Public Hospital purposes. – (Rs 9721).

**MYRTLEFORD** – The temporary reservation by Order in Council of 21 January 1997 of an area of 14.20 hectares, more or less, of land in the Parish of Myrtleford as a site for Public Purposes (Rail Trail), so far only as the portion containing 895 square metres, more or less, as indicated by hatching on plan published in the Government Gazette on 10 June 2004 page 1659. – (Rs 1109905).

**RUPANYUP** – The temporary reservation by Order in Council of 28 June 1880 of an area of 8094 square metres of land in the Parish of Rupanyup (formerly part of Crown Allotment 96) as a site for a Pound. – (Rs 5986).

**RUPANYUP** – The temporary reservation by Order in Council of 8 April 1885 of an area of 1.336 hectares of land in the Parish of Rupanyup (formerly part of Crown Allotment 96) as a site for Water Supply purposes, **SAVE AND EXCEPT** the portion containing 4148 square metres shown as Crown Allotment 96P, Parish of Rupanyup on Original Plan No. 111000 lodged in the Central Plan Office. – (C43413).

**RUPANYUP** – The temporary reservation by Order in Council of 7 January 1878 of an area of 178.06 hectares, more or less, of land in

the Parish of Rupanyup (formerly Crown Allotment 96) as a site for Public purposes, revoked as to part by various Orders, so far as the balance remaining. – (Rs 6507).

**WILLENABRINA** – The temporary reservation by Order in Council of 4 November 1953 of an area of 5.944 hectares, more or less, of land in the Parish of Willenabrina as a site for Water Supply purposes. – (Rs 884).

This Order is effective from the date on which it is published in the Government Gazette.

Dated 27 July 2004

Responsible Minister  
**MARY DELAHUNTY**  
 Minister for Planning

DIANE CASEY  
 Clerk of the Executive Council

**Crown Land (Reserves) Act 1978**  
**TEMPORARY RESERVATION**  
**OF CROWN LANDS**

The Lieutenant-Governor as the Governor's deputy, with the advice of the Executive Council, under section 4(1) of the **Crown Land (Reserves) Act 1978** temporarily reserves the following Crown lands which in his opinion are required for the purposes mentioned:–

**MUNICIPAL DISTRICT OF THE**  
**CITY OF BOROONDARA**

**BOROONDARA** – Public purposes (Health and Community purposes), 4422 square metres, being Crown Allotment 101A, Parish of Boroondara as indicated by hatching on plan hereunder. – (GP1548) – (Rs 37294).

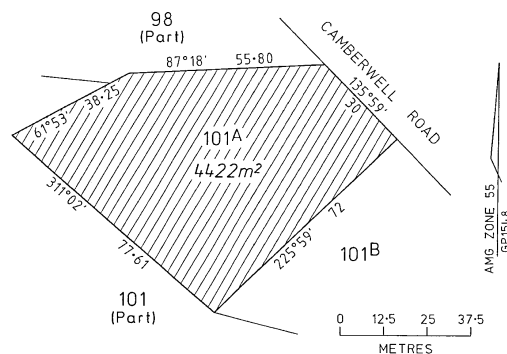

MUNICIPAL DISTRICT OF THE COLAC OTWAY SHIRE COUNCIL

CRESSY – Public purposes (Police purposes), 1211 square metres, being Crown Allotment 2001, Township of Cressy, Parish of Cressy as indicated by hatching on plan hereunder. – (GP1543) – (052013765).

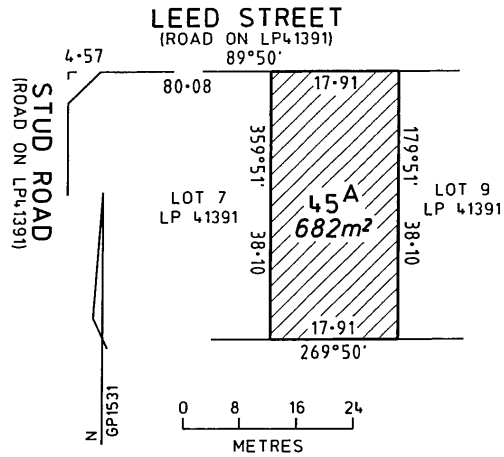

MUNICIPAL DISTRICT OF THE HORSHAM RURAL CITY COUNCIL

DOOEN – Conservation of an area of natural interest, 191 hectares, more or less, being Crown Allotment 2001, Parish of Dooen as shown on Original Plan No. 122043 lodged in the Central Plan Office of the Department of Sustainability and Environment. – (024847).

MUNICIPAL DISTRICT OF THE CITY OF BANYULE

KEELBUNDORA – Conservation of an area of natural interest, 13.66 hectares, being Crown Allotments 9H and 16T3, Parish of Keelbundora as indicated by hatching on plan hereunder. – (GP1528) – (Rs 1436).

MUNICIPAL DISTRICT OF THE GREATER DANDENONG CITY COUNCIL

DANDENONG – Public purposes (Health purposes), 620 square metres, being Crown Allotment 43M, Parish of Dandenong as indicated by hatching on plan hereunder. – (GP1530) – (C99515).

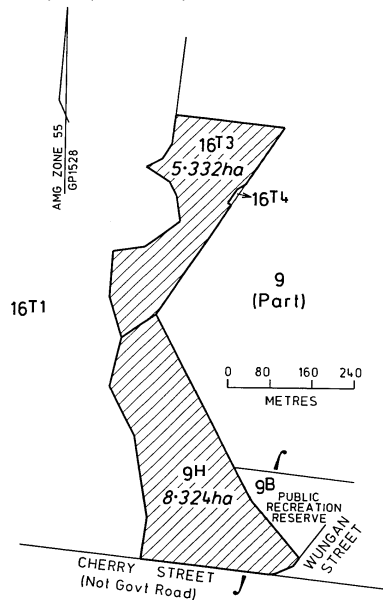
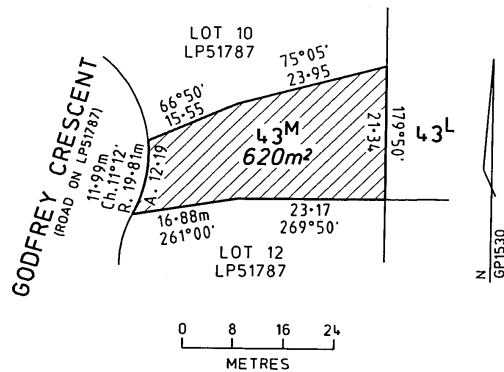

TOTAL AREA OF HATCHED PORTIONS IS 13.66ha.

MUNICIPAL DISTRICT OF THE GREATER DANDENONG CITY COUNCIL

DANDENONG – Public purposes (Health purposes), 682 square metres, being Crown Allotment 45A, Parish of Dandenong as indicated by hatching on plan hereunder. – (GP1531) – (12L12-1536).

MUNICIPAL DISTRICT OF THE  
MILDURA RURAL CITY COUNCIL

MILDURA – Public purposes (Horticultural Research purposes), 4.046 hectares being Crown Allotment 2079, Parish of Mildura as indicated by hatching on plan hereunder. – (GP1549) – (Rs 07411).

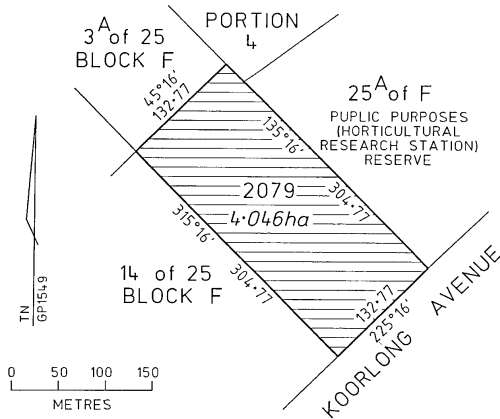

MUNICIPAL DISTRICT OF THE  
BALLARAT CITY COUNCIL

NERRINA – Public Recreation, 2.5 hectares, more or less, being Crown Allotment 52C, Section AA, Township of Nerrina, Parish of Ballarat as indicated by hatching on plan hereunder. – (GP1542) – (052013741).

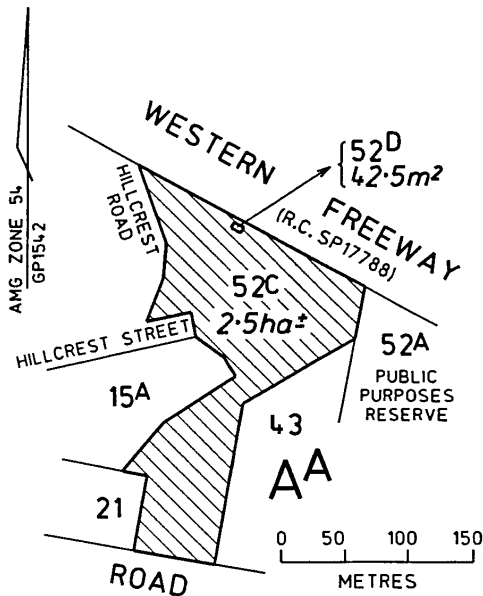

MUNICIPAL DISTRICT OF THE  
SWAN HILL RURAL CITY COUNCIL

NYAH – Public purposes (Police purposes), 1012 square metres, being Crown Allotment 2001, Township of Nyah, Parish of Tyntynder North as indicated by hatching on plan hereunder. – (GP1539) – (2013774).

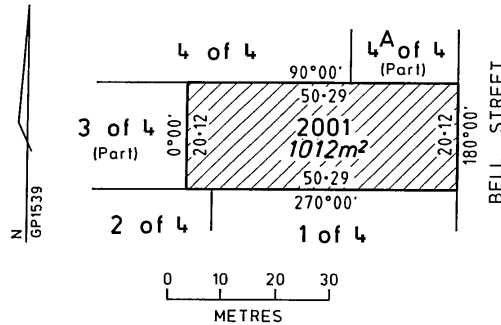

MUNICIPAL DISTRICT OF THE  
YARRIAMBIACK SHIRE COUNCIL

RUPANYUP – Management of wildlife and preservation of wildlife habitat, total area 53 hectares, more or less, being Crown Allotments 96R and 96S, Parish of Rupanyup as indicated by hatching on plan hereunder. – (GP1228) – (Rs 6507).

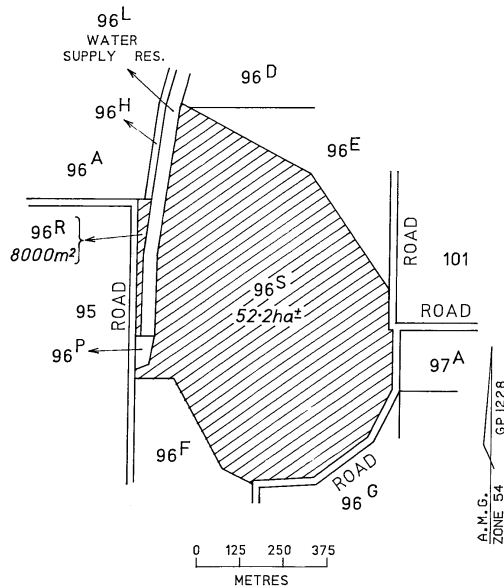

MUNICIPAL DISTRICT OF THE  
MOUNT ALEXANDER SHIRE COUNCIL

TARADALE – Public purposes (Mineral Springs), area 1.47 hectares, more or less, being

Crown Allotment 2003, Township of Taradale, Parish of Elphinstone as indicated by hatching on plan hereunder. – (GP1534) – (Rs 3760).

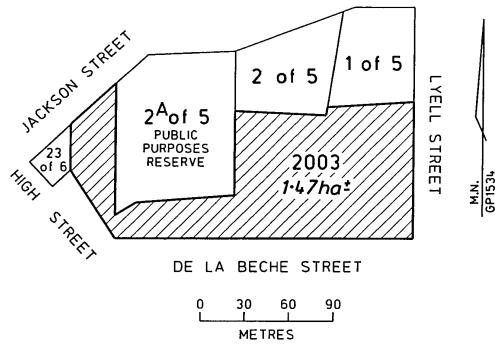

MUNICIPAL DISTRICT OF THE SWAN HILL RURAL CITY COUNCIL

TYNTYNDER NORTH – Conservation of an area of natural interest, combined area 29.5 hectares, more or less, being Crown Allotments 2002, 2003 and 2004, and Crown Allotment 6D, Section 1, Parish of Tyntynder North as shown hatched on Plan No. LEGL./04-205 lodged in the Central Plan Office of the Department of Sustainability and Environment. – (Rs 13782).

MUNICIPAL DISTRICT OF THE YARRIAMBIAK SHIRE COUNCIL

WILLENABRINA – Conservation of an area of natural interest, 5.90 hectares, more or less, being Crown Allotment 2B, Parish of Willenabrina as indicated by hatching on plan hereunder. – (GP1438) – (024503).

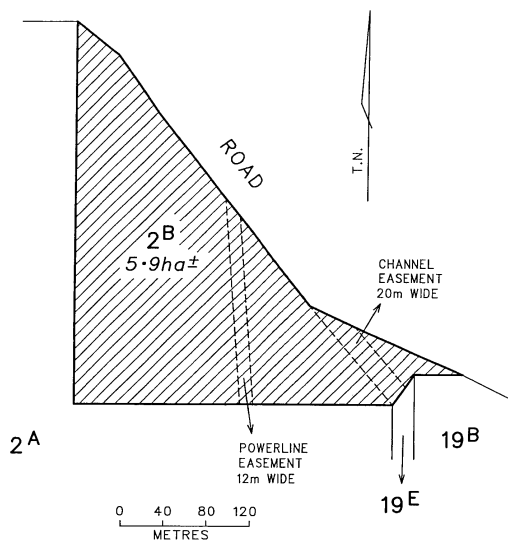

This Order is effective from the date on which it is published in the Government Gazette.

Dated 27 July 2004

Responsible Minister  
MARY DELAHUNTY  
Minister for Planning

DIANE CASEY  
Clerk of the Executive Council

Land Act 1958

CLOSURE OF UNUSED ROAD

The Lieutenant-Governor as the Governor's deputy, with the advice of the Executive Council, under section 349 of the Land Act 1958 and with the concurrence in writing of the municipality in which the road is situated closes the following unused road:

MUNICIPAL DISTRICT OF THE NORTHERN GRAMPIANS SHIRE COUNCIL

GLYNWYLLN – The road in the Parish of Glynwylln being Crown Allotment 2002 as indicated by hatching on plan hereunder. – (GP1319) – (02P022086).

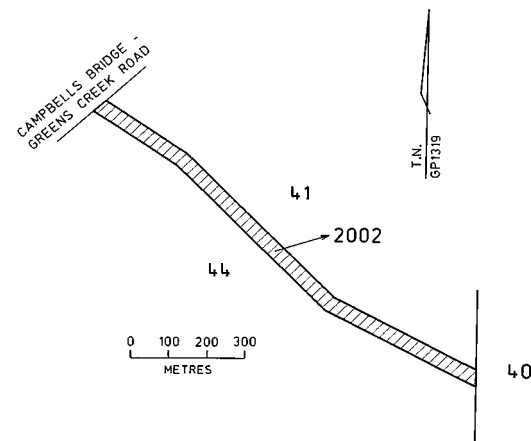

This Order is effective from the date on which it is published in the Government Gazette.

Dated 27 July 2004

Responsible Minister  
MARY DELAHUNTY  
Minister for Planning

DIANE CASEY  
Clerk of the Executive Council

**Land Act 1958**

**CLOSURE OF UNUSED ROADS**

The Lieutenant-Governor as the Governor's deputy, with the advice of the Executive Council, under section 349 of the **Land Act 1958** and with the concurrence in writing of the municipalities in which the roads are situated and the owners of land adjoining those roads closes the following unused roads:

**MUNICIPAL DISTRICT OF THE PYRENEES SHIRE COUNCIL**

**GLENDHU** – The road in the Parish of Glendhu being Crown Allotment 2001 as indicated by hatching on plan hereunder. – (GP1294) – (06L6-10291).

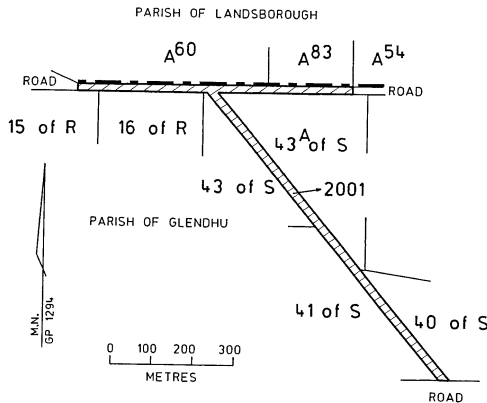

**MUNICIPAL DISTRICT OF THE MOUNT ALEXANDER SHIRE COUNCIL**

**TARADALE** – The road in the Township of Taradale, Parish of Elphinstone, being Crown Allotment 2002 as indicated by hatching on plan hereunder. – (GP1533) – (06P131124).

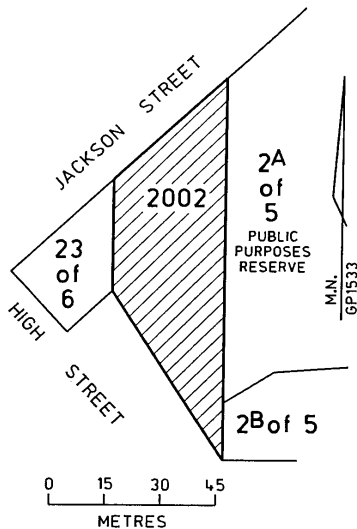

This Order is effective from the date on which it is published in the Government Gazette.

Dated 27 July 2004

Responsible Minister  
**MARY DELAHUNTY**  
Minister for Planning

**DIANE CASEY**  
Clerk of the Executive Council

**Crown Land (Reserves) Act 1978**

**NOTICE OF INTENTION TO REVOKE TEMPORARY RESERVATION**

**Order in Council**

The Lieutenant-Governor as the Governor's deputy, with the advice of the Executive Council, under section 10 of the **Crown Land (Reserves) Act 1978** gives notice of intention to revoke the following temporary reservation:

**MELBOURNE** – The temporary reservation by Order in Council of 22 April 1936 of an area of 2.833 hectares, more or less, of land in the City of Melbourne, Parish of Melbourne North as a site for Public Purposes, revoked as to part by Orders in Council of 28 February 1950 and 30 September 1980 and further revoked as to various parts pursuant the **Melbourne City Link Act 1995** so far only as the portion containing 1.170 hectares, more or less, shown as Crown Allotment 2043, City of Melbourne, Parish of Melbourne North on Plan LEGL./04-027 lodged in the Central Plan Office of the Department of Sustainability and Environment. – (Rs 4551).

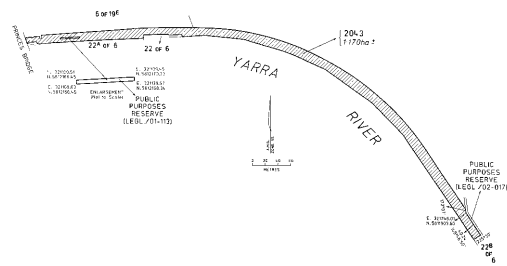

This Order is effective from the date on which it is published in the Government Gazette.

Dated 27 July 2004

Responsible Minister  
**MARY DELAHUNTY**  
Minister for Planning

**DIANE CASEY**  
Clerk of the Executive Council

**Parliamentary Committees Act 2003**REFERRAL OF INQUIRY INTO PROMOTION  
OF MATHS AND SCIENCE EDUCATION  
TO THE EDUCATION AND TRAINING  
COMMITTEE OF PARLIAMENT

## Order in Council

The Lieutenant-Governor as the Governor's deputy, with the advice of the Executive Council, under Section 33(1)(b) of the **Parliamentary Committees Act 2003**, approves the referral of an inquiry into the Promotion of Maths and Science Education, to the Education and Training Committee of Parliament.

The terms of reference are outlined in the Schedule to this Order.

Dated 27 July 2004

Responsible Minister  
STEVE BRACKS  
Premier

DIANE CASEY

Clerk of the Executive Council

**Parliamentary Committees Act 2003**REFERRAL OF INQUIRY INTO THE  
PROMOTION OF MATHS AND SCIENCE  
EDUCATION TO THE EDUCATION AND  
TRAINING COMMITTEE OF PARLIAMENT**SCHEDULE TO THE  
ORDER IN COUNCIL**

Education and Training  
Committee of Parliament

## Terms of Reference

## Promotion of Maths and Science Education

To inquire into and report to Parliament on opportunities to promote maths and science in Victorian education.

In particular, the Committee is requested to:

1. Determine which factors will support high quality teaching and learning of mathematics and science including teaching method and environment, subject knowledge, pedagogy, and teaching expertise.
2. Examine national and international trends and report on innovative initiatives that promote the teaching and learning of maths and science.
3. Determine how best practice in teaching of maths and science can be shared among

schools and other education communities and identify other opportunities for cross government action.

4. Determine how new business, industry and research applications of mathematics and science can be integrated into schools and learning communities.
5. Examine the potential for greater cross-sectoral links between industry, tertiary and training institutions and schools in the promotion of mathematics and science education.
6. Examine gender issues in the teaching and learning of mathematics and science education.
7. Consider ways of promoting greater interest by suitably qualified people to undertake mathematics and/or science teaching careers.

The Committee is to report to Parliament by September 2005.



**Drugs, Poisons and Controlled Substances Act 1981**  
 AMENDMENT OF AUTHORITY TO SELL OR  
 SUPPLY HYPODERMIC NEEDLES AND SYRINGES

Schedule to the Order in Council

The Lieutenant-Governor as the Governor's deputy, with the advice of the Executive Council, acting under section 80(5)(b) of the **Drugs, Poisons and Controlled Substances Act 1981** ("the Act"), and on the recommendation of the Minister for Health, by this Order amends alters or varies the Order made by the Governor in Council on 6 December 1994 as amended altered or varied by the Orders made by the Governor in Council on 11 April 1995, 29 August 1995, 25 June 1996, 6 August 1996, 18 February 1997, 20 May 1997, 9 September 1997, 25 November 1997, 28 April 1998, 28 July 1998, 4 November 1998, 14 December 1999, 18 April 2000, 26 September 2000, 6 February 2002 and 12 August 2003 authorising the sale or supply of hypodermic needles and syringes by a specified person or organisation or specified class of persons or organisations in specified circumstances as follows:

- (a) by **substituting** for registration number 26

26

26	Health and welfare workers, reception and administrative staff employed by the Bass Coast Community Health Service Inc, 1 Back Beach Road, San Remo.	At the Centre between 9.00 am and 5.00 pm Monday to Friday.
----	--	---

- (b) by **substituting** for registration number 39

39

39	Community development workers employed by the Western Region Health Centre, 4-12 Buckley Street, Footscray.	From the Service between 10.00 am and 6.00 pm Monday to Friday, 10.00 am and 2.00 pm Saturday and from an outreach service within the municipalities of Brimbank, Hobsons Bay, Maribyrnong, Melbourne, Melton, Moonee Valley, Moreland and Wyndham 24 hours per day, seven days a week.
----	---	---

- (c) by **substituting** for registration number 68

68

68	Health and welfare workers, reception and administrative staff and project and special program staff employed by the Western Region Alcohol and Drug Centre (WRAD), 26 Fairy Street, Warrnambool.	At the Centre between 9.00 am and 5.30 pm Monday to Friday and from an outreach service in the municipalities of Warrnambool, Corangamite and Moyne 24 hours per day, seven days a week.
----	---	--



82 (d) by **substituting** for registration number 82

82	Health and welfare workers and reception and administrative staff employed by the Whitehorse Community Health Service, 43 Carrington Road, Box Hill.	At the Centre between 8.30 am and 5.00 pm Monday to Friday.
----	--	---

84 (e) by **substituting** for registration number 84

84	Community development workers employed by Peninsula Health (Southern Hepatitis/HIV/AIDS Resource and Prevention Service – SHARPS), 39 Ross Smith Avenue, Frankston.	At the Centre between 9.30 am and 5.00 pm Monday to Friday and from an outreach service in the municipalities of Casey, Frankston, Greater Dandenong, Kingston, Monash and Mornington Peninsula between 6.30 pm and 10.30 pm seven days a week.
----	---	---

162 (f) by **substituting** for registration number 162

162	Health and welfare workers, reception and administrative staff and managers employed by Cardinia Casey Community Health Service, 140–155 Sladen Street, Cranbourne.	At the Centre between 9.00 am and 4.30 pm Monday to Friday.
-----	---	---

220 (g) by **substituting** for registration number 220

220	Community development workers employed by the Whitehorse Community Health Service, 43 Carrington Road, Box Hill.	Outreach service in the municipalities of Boroondara, Knox, Manningham, Maroondah, Monash, Whitehorse and Yarra Ranges between 7.30 pm and 11.30 pm seven days a week.
-----	--	--

228 (h) by **inserting** after registration number 227  
Specified Persons or Class of Persons

228	Health and welfare workers employed by Swinburne University – Croydon campus, 12–50 Norton Road, Croydon.	Specified Circumstances At the Centre between 10.00 am and 3.00 pm Monday to Thursday.
-----	---	---

229 Specified Persons or Class of Persons Specified Circumstances

229	Registered nurses employed by Swinburne University – Lilydale campus, Melba Avenue, Lilydale.	At the Centre between 9.30am and 4.01 pm Monday to Friday.
-----	---	--

230	Specified Persons or Class of Persons	Specified Circumstances
230	Health and welfare workers employed by Swinburne University – Wantirna campus, 369 Stud Road, Wantirna.	At the Centre between 10.00 am and 3.00 pm Monday to Thursday.
231	Specified Persons or Class of Persons	Specified Circumstances
231	Allied health and reception staff employed by the Violet Town Bush Nursing Centre – Hume Corridor Community Outreach Health Service, Cowslip Street, Violet Town.	At the Centre between 8.30 and 1.00 pm Monday to Friday.
232	Specified Persons or Class of Persons	Specified Circumstances
232	Health and welfare workers and reception and administrative staff employed by the Western District Health Service – Frances Hewett Community Centre, cnr Roberts and Tyre Streets, Hamilton.	At the Centre between 9.00 am and 5.00 pm Monday to Friday.

This order becomes effective on the day it is published in the Government Gazette.

Dated 27 July 2004

Responsible Minister  
HON BRONWYN PIKE MP  
Minister for Health

DIANE CASEY  
Clerk of the Executive Council

**SUBORDINATE LEGISLATION ACT 1994  
NOTICE OF MAKING OF STATUTORY  
RULES**

Notice is hereby given under Section 17 (2) of the **Subordinate Legislation Act 1994** of the making of the following Statutory Rules:

94. *Statutory Rule:* Magistrates' Court General (Infringements) Regulations 2004  
*Authorising Act:* Magistrates' Court Act 1989  
*Date of making:* 27 July 2004
95. *Statutory Rule:* Court Security Regulations 2004  
*Authorising Act:* Court Security Act 1980  
*Date of making:* 27 July 2004
96. *Statutory Rule:* Wildlife (Whales) (Amendment) Regulations 2004  
*Authorising Act:* Wildlife Act 1975  
*Date of making:* 27 July 2004
97. *Statutory Rule:* Planning and Environment (Amendment) Regulations 2004  
*Authorising Act:* Planning and Environment Act 1987  
*Date of making:* 27 July 2004
98. *Statutory Rule:* Subdivision (Procedures) (Amendment) Regulations 2004  
*Authorising Act:* Subdivision Act 1988  
*Date of making:* 27 July 2004
99. *Statutory Rule:* Subordinate Legislation (Teaching Service (Merit Protection Board) (Appeal) Regulations 1994 – Extension of Operation) Regulations 2004  
*Authorising Act:* Subordinate Legislation Act 1994  
*Date of making:* 27 July 2004

**SUBORDINATE LEGISLATION ACT 1994  
NOTICE THAT STATUTORY RULES ARE  
OBTAINABLE**

Notice is hereby given under Section 17 (3) of the **Subordinate Legislation Act 1994** that the following Statutory Rules were first obtainable from Information Victoria, 356 Collins Street, Melbourne on the date specified:

92. *Statutory Rule:* Treasury Corporation of Victoria (Prescribed Agencies) Regulations 2004  
*Authorising Act:* Treasury Corporation of Victoria Act 1992  
*Date first obtainable:* 29 July 2004  
*Code A*
93. *Statutory Rule:* Subordinate Legislation (Occupational Health and Safety (Certification of Plant Users and Operators) Regulations 1994 – Extension of Operation) Regulations 2004  
*Authorising Act:* Subordinate Legislation Act 1994  
*Date first obtainable:* 29 July 2004  
*Code A*

**PRICING FOR SPECIAL GAZETTE,  
PERIODICAL GAZETTE AND  
VICTORIAN LEGISLATION**

Retail price varies according to the number of pages in each Victoria Government Special Gazette, Victoria Government Periodical Gazette and Victorian legislation. The table below sets out the prices that apply.

<i>Price Code</i>	<i>No. of Pages (Including cover and blank pages)</i>	<i>Price*</i>
A	1–16	\$3.70
B	17–32	\$5.50
C	33–48	\$7.55
D	49–96	\$11.75
E	97–144	\$15.20
F	145–192	\$17.95
G	193–240	\$20.70
H	241–288	\$22.05
I	289–352	\$24.80
J	353–416	\$29.00
K	417–480	\$33.10
L	481–544	\$38.60
M	545–608	\$44.10
N	609–672	\$49.65
O	673–736	\$55.10
P	737–800	\$60.65

*\*All Prices Include GST*

**craftsmanpress**

The *Victoria Government Gazette* is published by The Craftsman Press Pty Ltd with the authority of the Government Printer for the State of Victoria

© State of Victoria 2004

This publication is copyright. No part may be reproduced by any process except in accordance with the provisions of the Copyright Act.

Address all enquiries to the Government Printer for the State of Victoria  
Level 2 1 Macarthur Street  
Melbourne 3002  
Victoria Australia

**How To Order**

**Mail Order**      **Craftsman Press Pty Ltd**  
125 Highbury Road  
Burwood 3125  
DX – 32510 Burwood



**Telephone**      (03) 9926 1233



**Fax**      (03) 9926 1292

**email**      [gazette@craftpress.com.au](mailto:gazette@craftpress.com.au)



**Retail & Mail Sales**      **Information Victoria**  
356 Collins Street  
Melbourne 3000



**Telephone**      1300 366 356



**Fax**      (03) 9603 9920



**Retail Sales**      **City Graphics**  
Level 1 520 Bourke Street  
Melbourne 3000



**Telephone**      (03) 9600 0977



**Fax**      (03) 9600 0989

**Recommended Retail Price \$1.95 (includes GST)**

ISSN 0819-5471



9 770819 550386