



# Victoria Government Gazette

No. S 17 Wednesday 31 January 2007  
By Authority, Victorian Government Printer

## Land Acquisition and Compensation Act 1986 FORM 7

### Notice of Acquisition

#### Compulsory Acquisition of Interest in Land

To: Bryon David Francis McIntosh as Registered Proprietor  
To: Adrian Keith McIntosh as Registered Proprietor  
To: Rural Finance Corporation of Victoria as Mortgagee under Mortgage No. P761288H

COLIBAN REGION WATER AUTHORITY, ABN 96 549 082 360, of 37-45 Bridge Street, Bendigo 3550 declares that by this notice it acquires the following interest in the land described as:  
Easement for the purposes of a pipeline for water over that piece of land being portion of the land comprised and described in Certificate of Title Volume 09709, Folio 846 and being the area marked "E-1" on the Plan annexed hereto ("the land").

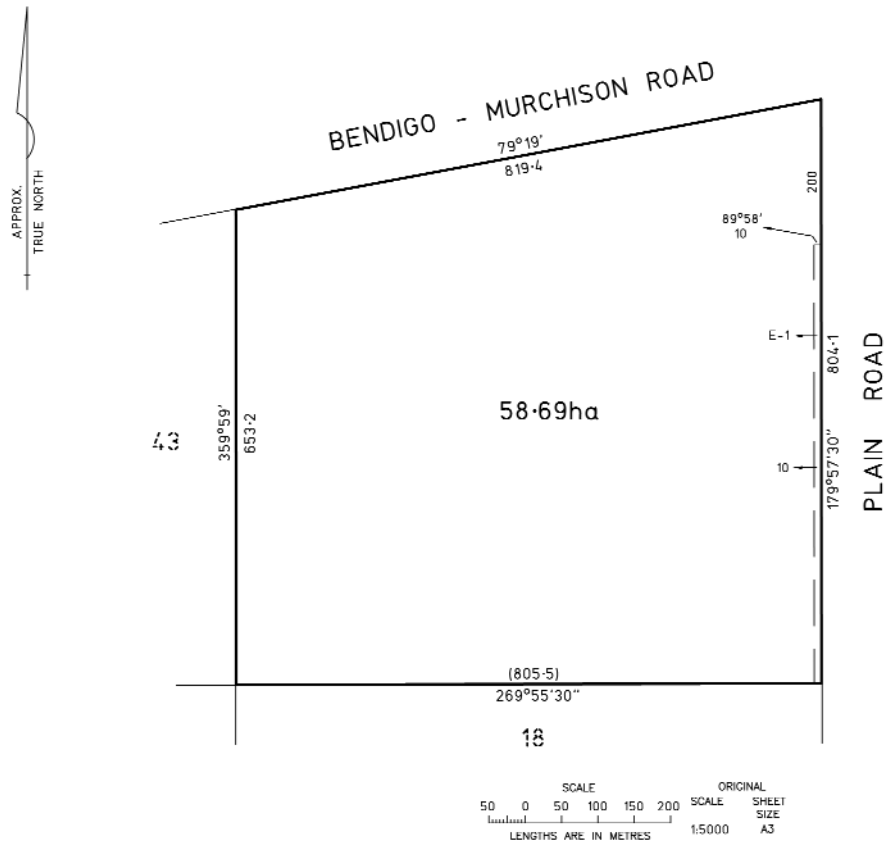

Published with the authority of COLIBAN REGION WATER AUTHORITY.  
Dated 30 January 2007

CHERYL FITZGERALD  
Corporate Secretary  
For and on behalf of  
COLIBAN REGION WATER AUTHORITY

**SPECIAL**

**Land Acquisition and Compensation Act 1986**

FORM 7

Notice of Acquisition

Compulsory Acquisition of Interest in Land

To: Darryl Gregory Rathjen as Registered Proprietor  
 To: Westpac Banking Corporation as Mortgagee under Mortgage No. U800631A

COLIBAN REGION WATER AUTHORITY, ABN 96 549 082 360, of 37-45 Bridge Street, Bendigo 3550 declares that by this notice it acquires the following interest in the land described as: Easement for the purposes of a pipeline for water over that piece of land being portion of the land comprised and described in Certificate of Title Volume 09982, Folio 279 and being the area marked "E-1" on the Plan annexed hereto ("the land").

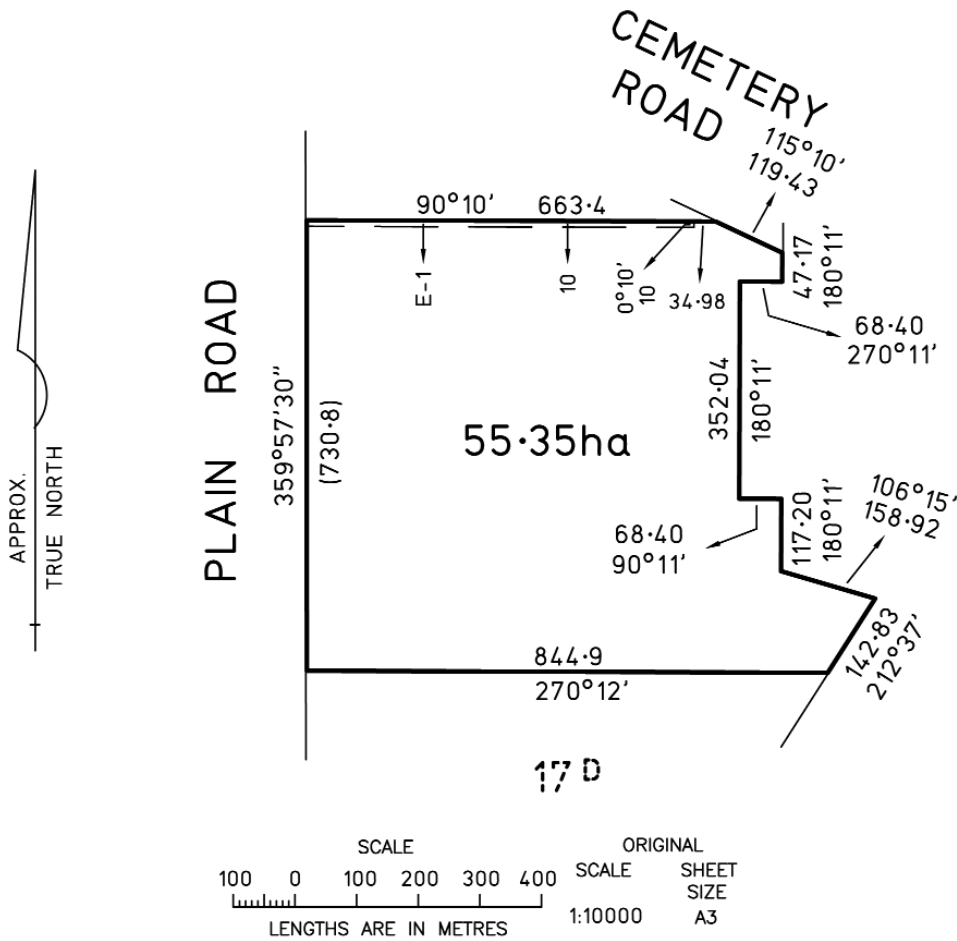

Published with the authority of COLIBAN REGION WATER AUTHORITY.  
 Dated 30 January 2007

CHERYL FITZGERALD  
 Corporate Secretary  
 For and on behalf of  
 COLIBAN REGION WATER AUTHORITY

**Land Acquisition and Compensation Act 1986**

**FORM 7**

Notice of Acquisition

Compulsory Acquisition of Interest in Land

To: Finlay Starritt Rathjen as Registered Proprietor  
To: Westpac Banking Corporation as Mortgagee under Mortgage No. 2481926Y

COLIBAN REGION WATER AUTHORITY, ABN 96 549 082 360, of 37-45 Bridge Street, Bendigo 3550 declares that by this notice it acquires the following interest in the land described as: Easement for the purposes of a pipeline for water over that piece of land being portion of the land comprised and described in Certificates of Title Volume 08067, Folio 120 and Volume 05589, Folio 785 and being the area marked "E-1" on the Plan annexed hereto ("the land").

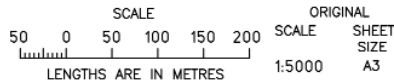
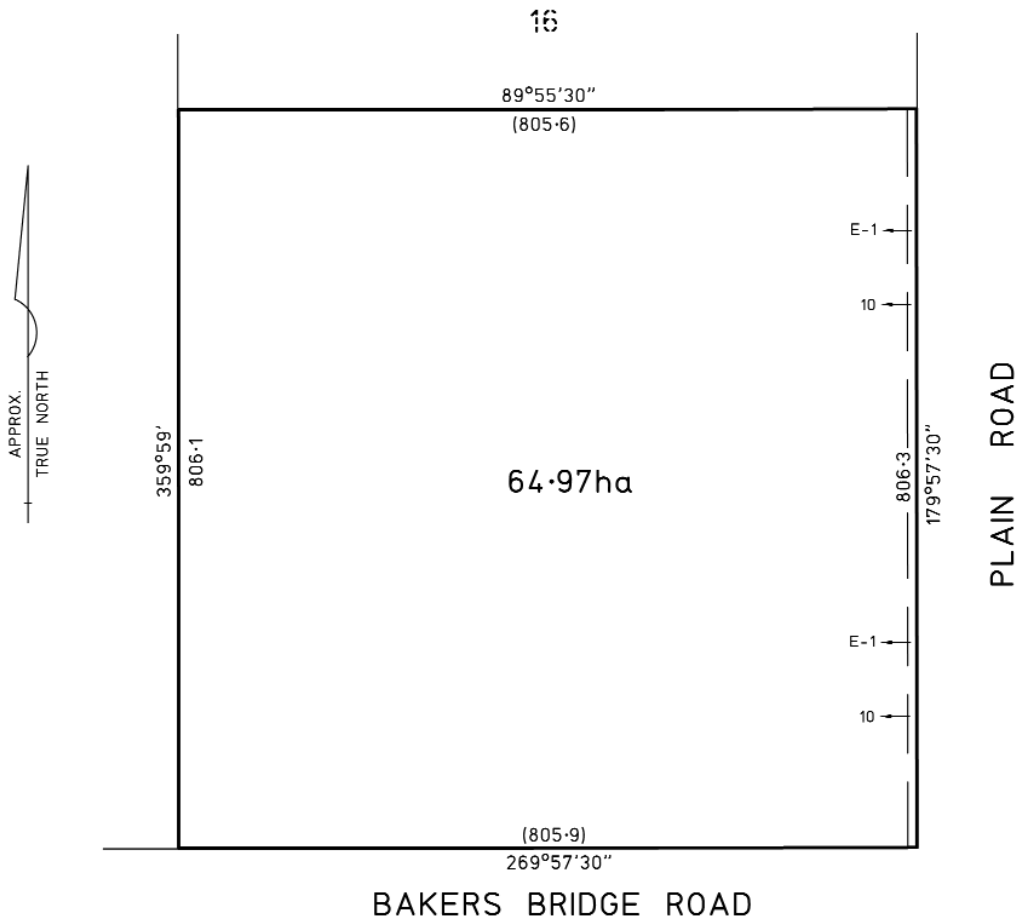

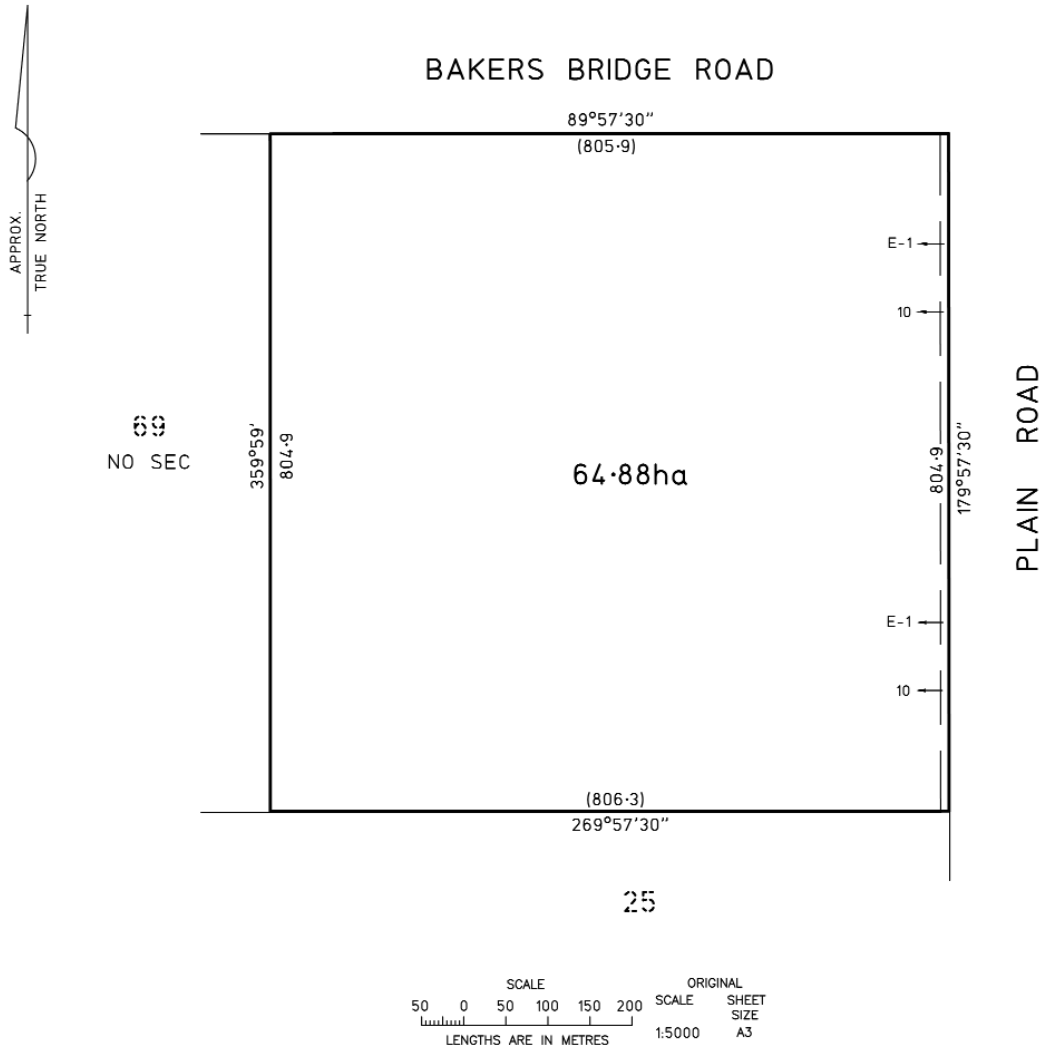

Published with the authority of COLIBAN REGION WATER AUTHORITY.  
Dated 30 January 2007

CHERYL FITZGERALD  
Corporate Secretary  
For and on behalf of  
COLIBAN REGION WATER AUTHORITY

**Land Acquisition and Compensation Act 1986****FORM 7**

## Notice of Acquisition

## Compulsory Acquisition of Interest in Land

To: Geoffrey Edward Weppner as Registered Proprietor  
 To: Johannes Leslie Weppner as Registered Proprietor  
 To: Peter Ronald Weppner as Registered Proprietor  
 To: Banksia Mortgages Ltd as Mortgagee under Mortgage No. V441195B  
 To: Banksia Securities Limited as Mortgagee under Mortgage No. V441196X

COLIBAN REGION WATER AUTHORITY, ABN 96 549 082 360, of 37-45 Bridge Street, Bendigo 3550 declares that by this notice it acquires the following interest in the land described as:  
 Easement for the purposes of a pipeline for water over that piece of land being portion of the land comprised and described in Certificate of Title Volume 10358, Folio 673 and being the area marked "E-1" on the Plan annexed hereto ("the land").

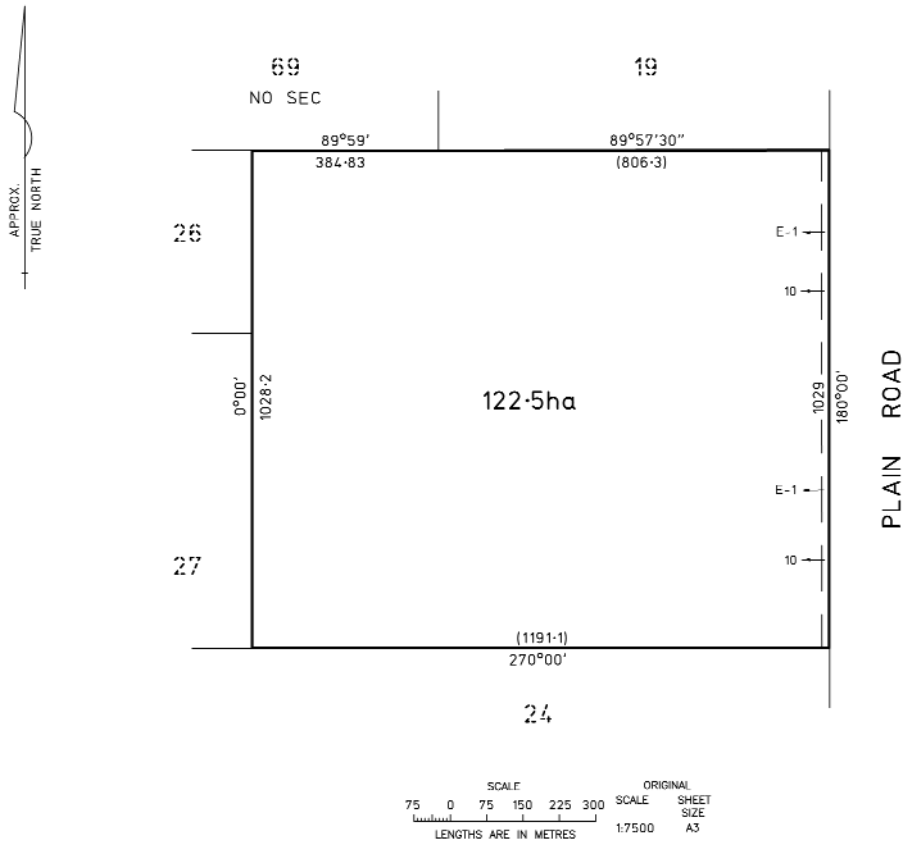

Published with the authority of COLIBAN REGION WATER AUTHORITY.  
 Dated 30 January 2007

CHERYL FITZGERALD  
 Corporate Secretary  
 For and on behalf of  
 COLIBAN REGION WATER AUTHORITY

Land Acquisition and Compensation Act 1986

FORM 7

Notice of Acquisition

Compulsory Acquisition of Interest in Land

To: Arthur David Vale as Registered Proprietor

COLIBAN REGION WATER AUTHORITY, ABN 96 549 082 360, of 37-45 Bridge Street, Bendigo 3550 declares that by this notice it acquires the following interest in the land described as: Easement for the purposes of a pipeline for water over that piece of land being portion of the land comprised and described in Certificate of Title Volume 07750, Folio 114 and being the area marked "E-1" on the Plan annexed hereto ("the land").

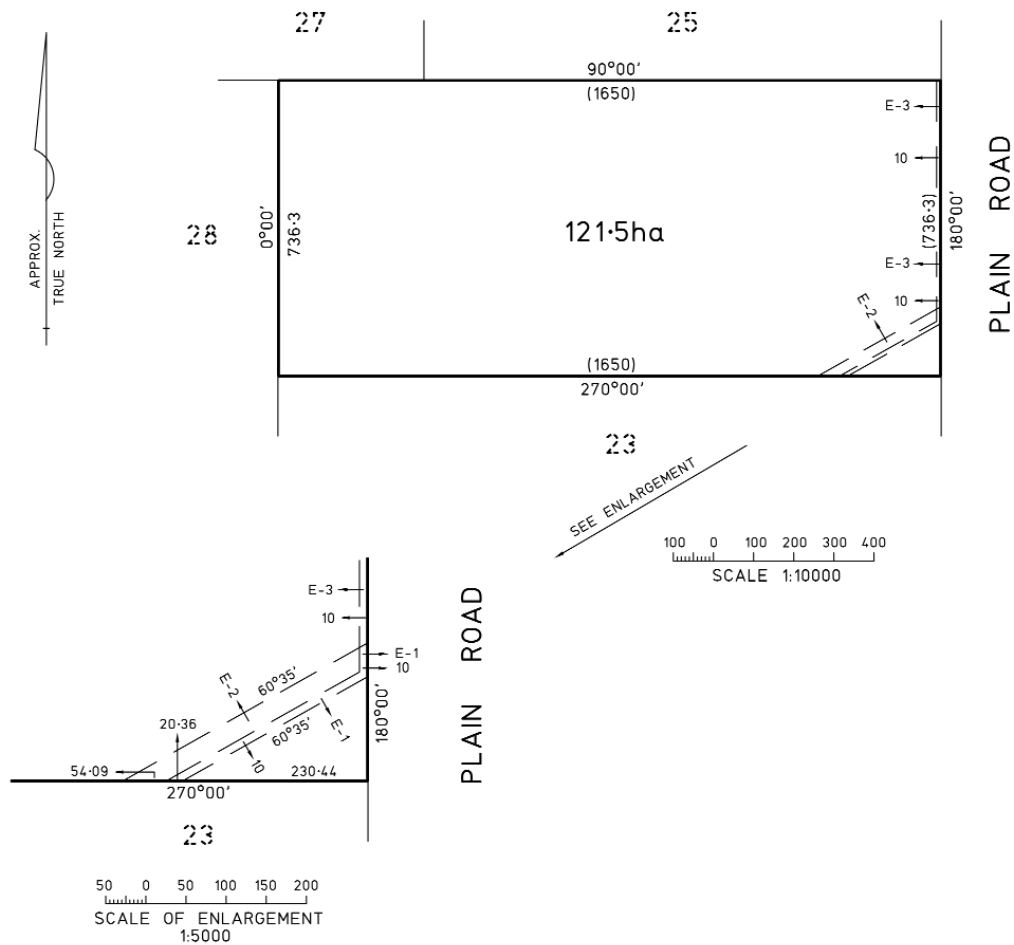

Published with the authority of COLIBAN REGION WATER AUTHORITY.  
Dated 30 January 2007

CHERYL FITZGERALD  
Corporate Secretary  
For and on behalf of  
COLIBAN REGION WATER AUTHORITY

**Land Acquisition and Compensation Act 1986**

**FORM 7**

**Notice of Acquisition**

**Compulsory Acquisition of Interest in Land**

To: Glenn Finlay Rathjen as Registered Proprietor  
 To: Catherine Maree Rathjen as Registered Proprietor  
 To: Westpac Banking Corporation as Mortgagee under Mortgage No. AC168465A

COLIBAN REGION WATER AUTHORITY, ABN 96 549 082 360, of 37-45 Bridge Street, Bendigo 3550 declares that by this notice it acquires the following interest in the land described as:  
 Easement for the purposes of a pipeline for water over that piece of land being portion of the land comprised and described in Certificate of Title Volume 09545, Folio 384 and being the area marked "E-1" on the Plan annexed hereto ("the land").

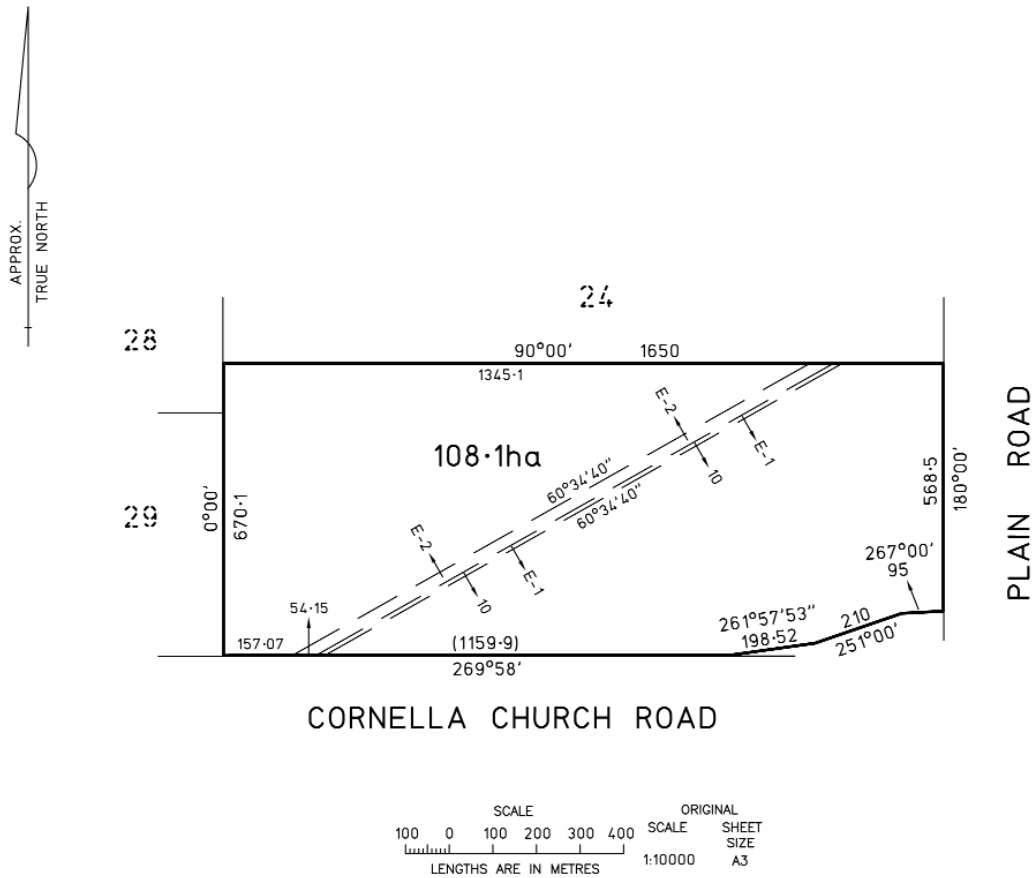

Published with the authority of COLIBAN REGION WATER AUTHORITY.  
 Dated 30 January 2007

CHERYL FITZGERALD  
 Corporate Secretary  
 For and on behalf of  
 COLIBAN REGION WATER AUTHORITY





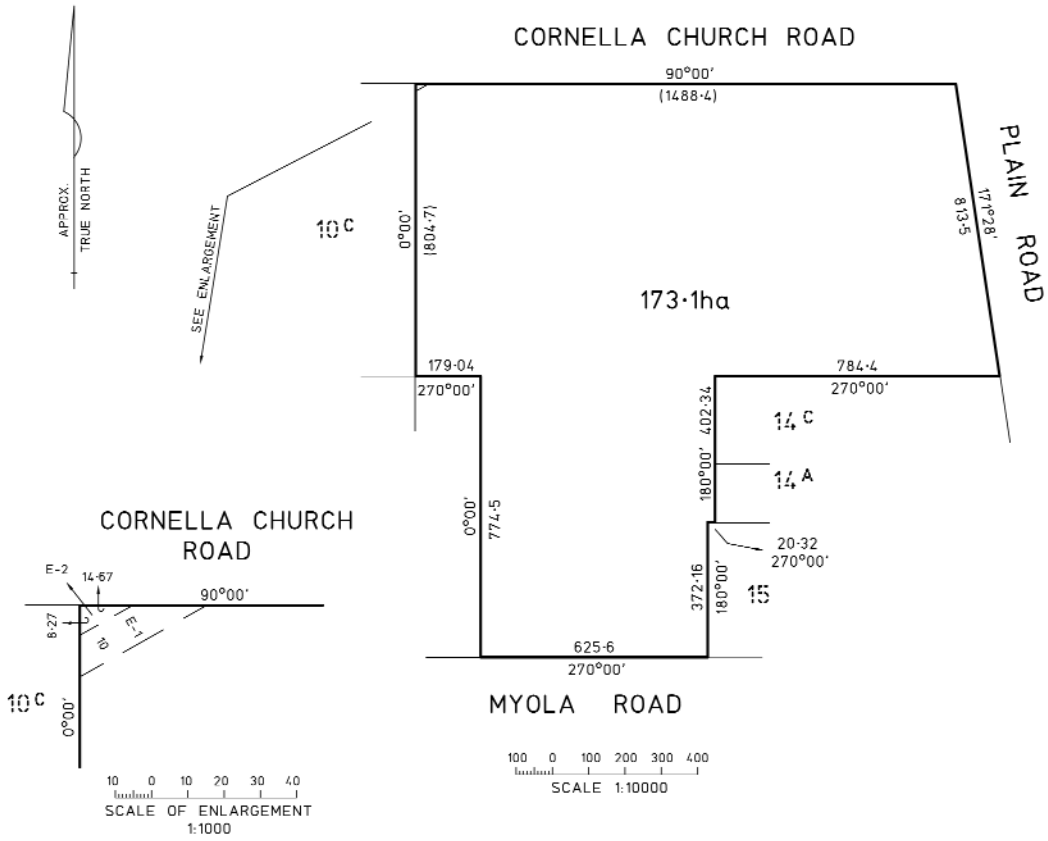

Published with the authority of COLIBAN REGION WATER AUTHORITY.  
 Dated 30 January 2007

CHERYL FITZGERALD  
 Corporate Secretary  
 For and on behalf of  
 COLIBAN REGION WATER AUTHORITY

**Land Acquisition and Compensation Act 1986**

**FORM 7**

**Notice of Acquisition**

**Compulsory Acquisition of Interest in Land**

- To: Lorraine Kerry Tuohey as Registered Proprietor
- To: Mark Joseph Tuohey as Registered Proprietor
- To: Thomas Charles Tuohey as Registered Proprietor
- To: Clem Tuohey as Registered Proprietor
- To: Donald Francis Tuohey as Registered Proprietor
- To: Peter Tuohey as Registered Proprietor

COLIBAN REGION WATER AUTHORITY, ABN 96 549 082 360, of 37-45 Bridge Street, Bendigo 3550 declares that by this notice it acquires the following interest in the land described as: Easement for the purposes of a pipeline for water over that piece of land being portion of the land comprised and described in Certificate of Title Volume 10530, Folio 163 and being the area marked "E-1" on the Plan annexed hereto ("the land").

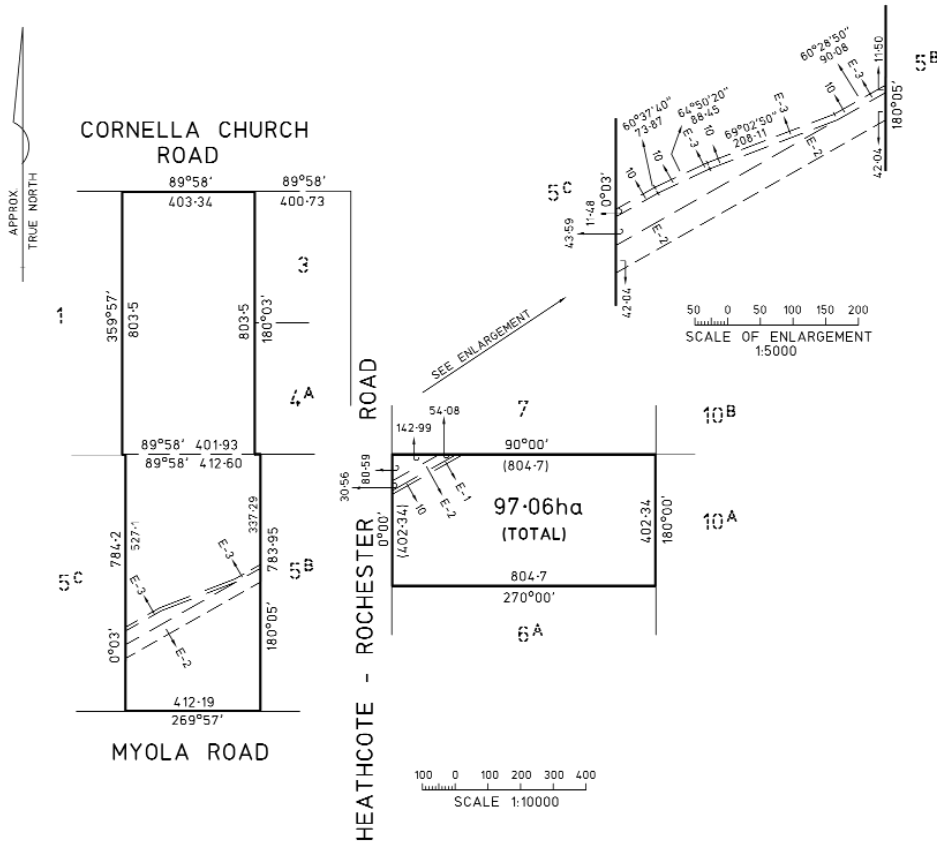

Published with the authority of COLIBAN REGION WATER AUTHORITY.  
 Dated 30 January 2007

CHERYL FITZGERALD  
 Corporate Secretary  
 For and on behalf of  
 COLIBAN REGION WATER AUTHORITY

**Land Acquisition and Compensation Act 1986**

FORM 7

Notice of Acquisition

Compulsory Acquisition of Interest in Land

To: Finlay Starritt Rathjen as Registered Proprietor

COLIBAN REGION WATER AUTHORITY, ABN 96 549 082 360, of 37–45 Bridge Street, Bendigo 3550 declares that by this notice it acquires the following interest in the land described as: Easement for the purposes of a pipeline for water over that piece of land being portion of the land comprised and described in Certificate of Title Volume 08354, Folio 937 and being the area marked “E-1” on the Plan annexed hereto (“the land”).

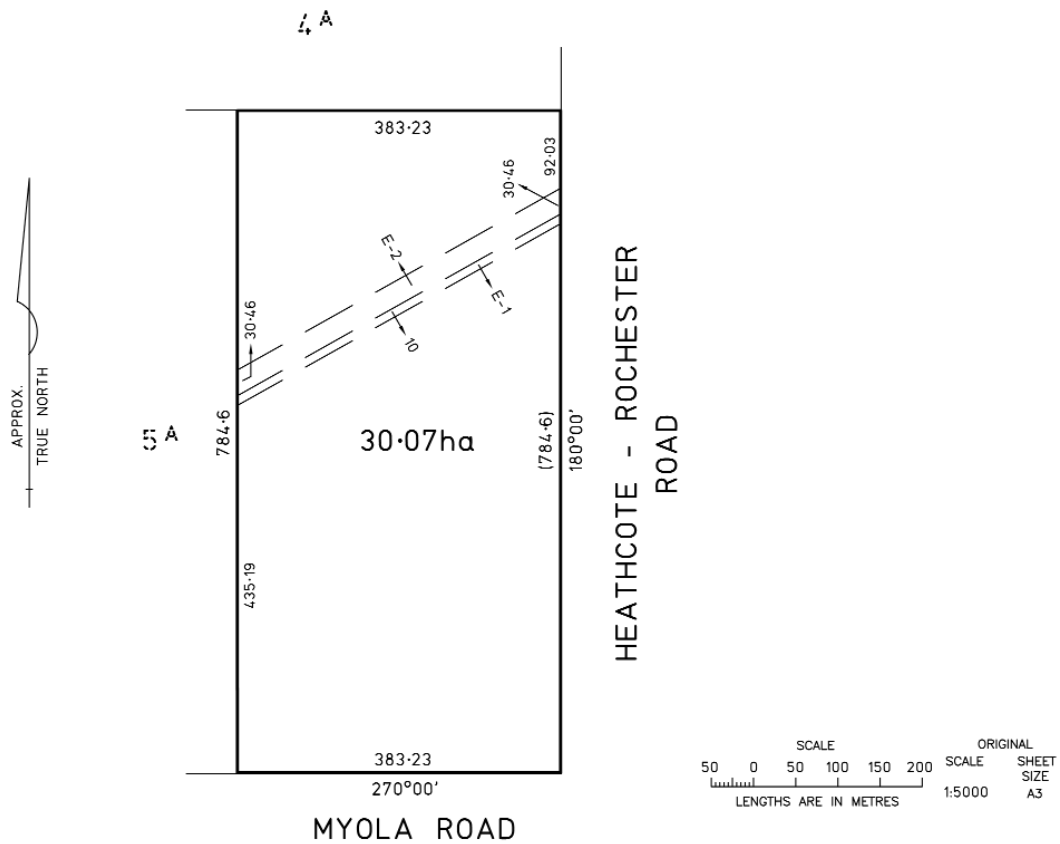

Published with the authority of COLIBAN REGION WATER AUTHORITY.  
Dated 30 January 2007

CHERYL FITZGERALD  
Corporate Secretary  
For and on behalf of  
COLIBAN REGION WATER AUTHORITY



**Land Acquisition and Compensation Act 1986**

**FORM 7**

**Notice of Acquisition**

**Compulsory Acquisition of Interest in Land**

To: Moira Margaret Dowd as Registered Proprietor

COLIBAN REGION WATER AUTHORITY, ABN 96 549 082 360, of 37-45 Bridge Street, Bendigo 3550 declares that by this notice it acquires the following interest in the land described as:

Easement for the purposes of a pipeline for water over that piece of land being portion of the land comprised and described in Certificates of Title Volume 03486, Folio 046, Volume 03486, Folio 047 and Volume 03486, Folio 049 and being the area marked "E-1" on the Plan annexed hereto ("the land").

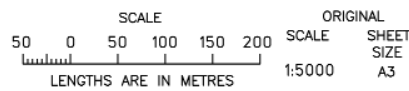
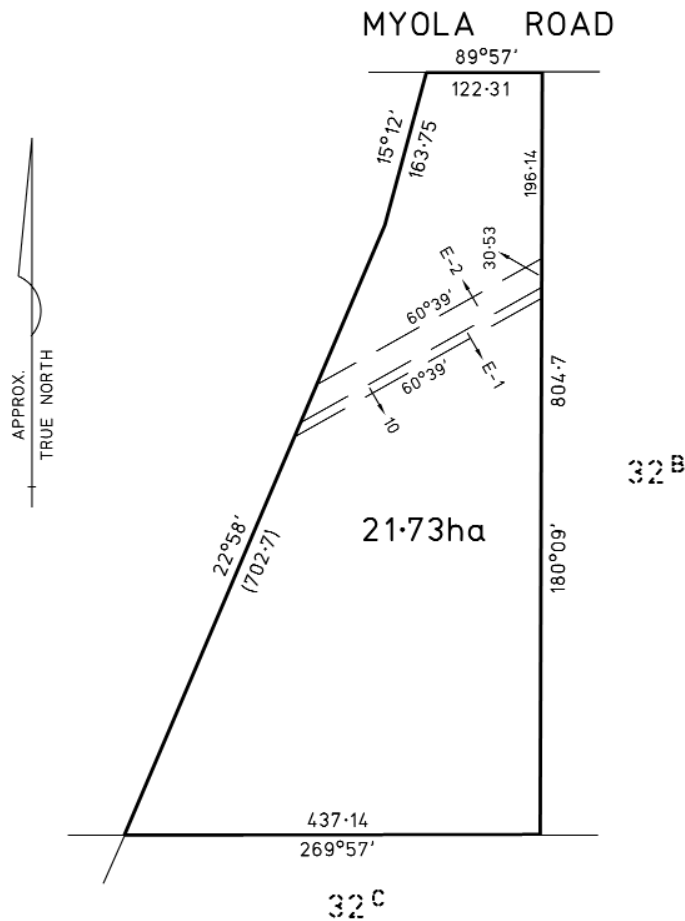

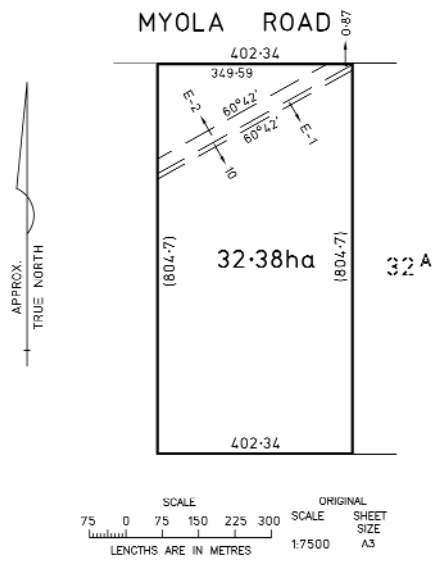
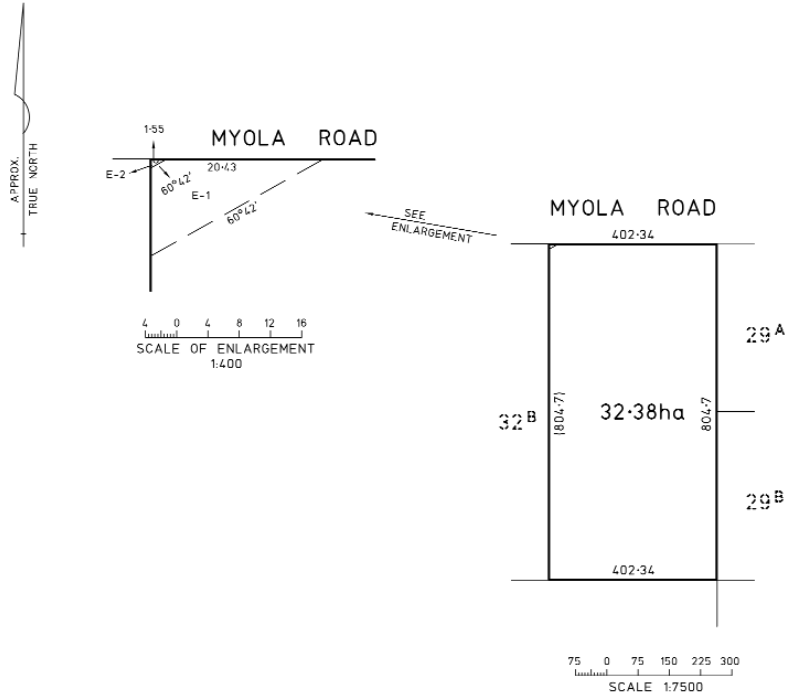

Published with the authority of COLIBAN REGION WATER AUTHORITY.  
 Dated 30 January 2007

CHERYL FITZGERALD  
 Corporate Secretary  
 For and on behalf of  
 COLIBAN REGION WATER AUTHORITY

Land Acquisition and Compensation Act 1986

FORM 7

Notice of Acquisition

Compulsory Acquisition of Interest in Land

To: Graeme Leslie Weeks as Registered Proprietor
To: Robyn Elizabeth Weeks as Registered Proprietor
To: Westpac Banking Corporation as Mortgagee under Mortgage No. G300241

COLIBAN REGION WATER AUTHORITY, ABN 96 549 082 360, of 37-45 Bridge Street, Bendigo 3550 declares that by this notice it acquires the following interest in the land described as: Easement for the purposes of a pipeline for water over that piece of land being portion of the land comprised and described in Certificates of Title Volume 09290, Folio 708 and Volume 08299, Folio 087 and being the area marked "E-1" on the Plan annexed hereto ("the land").

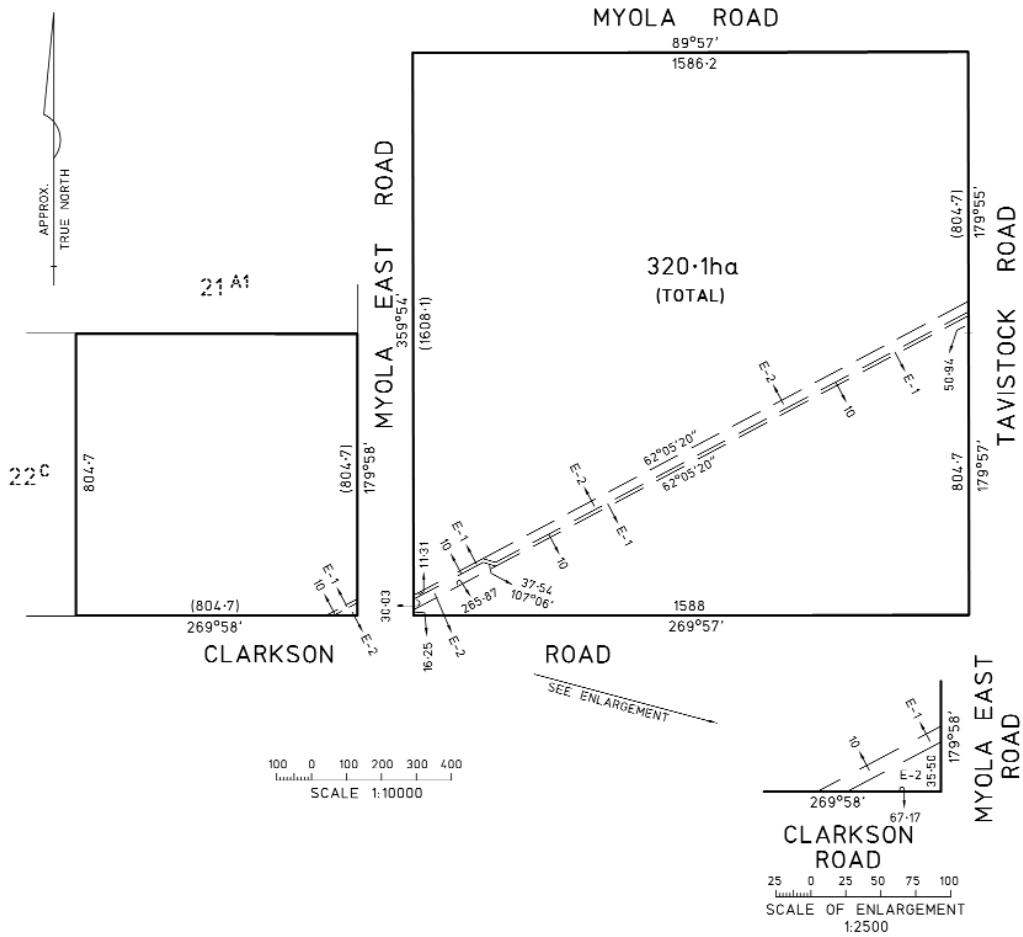

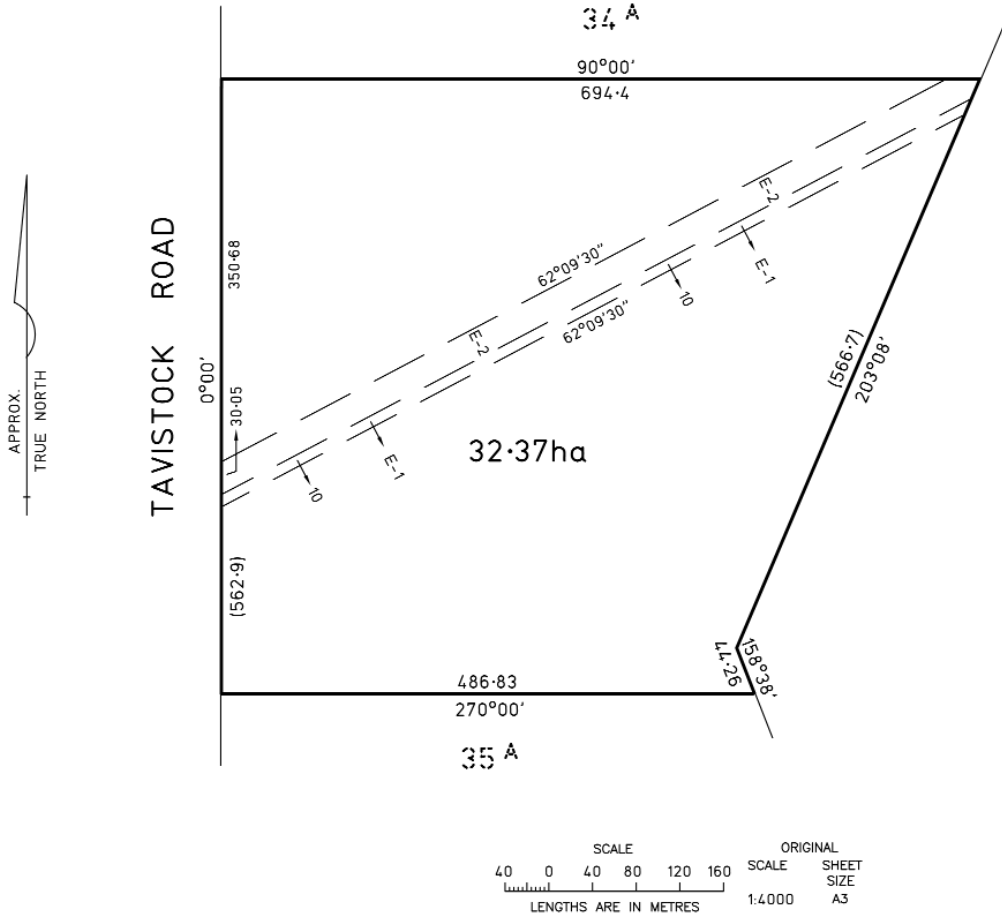

Published with the authority of COLIBAN REGION WATER AUTHORITY.  
 Dated 30 January 2007

CHERYL FITZGERALD  
 Corporate Secretary  
 For and on behalf of  
 COLIBAN REGION WATER AUTHORITY



**Land Acquisition and Compensation Act 1986**

**FORM 7**

**Notice of Acquisition**

**Compulsory Acquisition of Interest in Land**

To: Francis Victor Oliver as Registered Proprietor

To: Christine Oliver as Registered Proprietor

COLIBAN REGION WATER AUTHORITY, ABN 96 549 082 360, of 37-45 Bridge Street, Bendigo 3550 declares that by this notice it acquires the following interest in the land described as: Easement for the purposes of a pipeline for water over that piece of land being portion of the land comprised and described in Certificates of Title Volume 02861, Folio 050 and Volume 10366, Folio 449 and being the area marked "E-1" on the Plan annexed hereto ("the land").

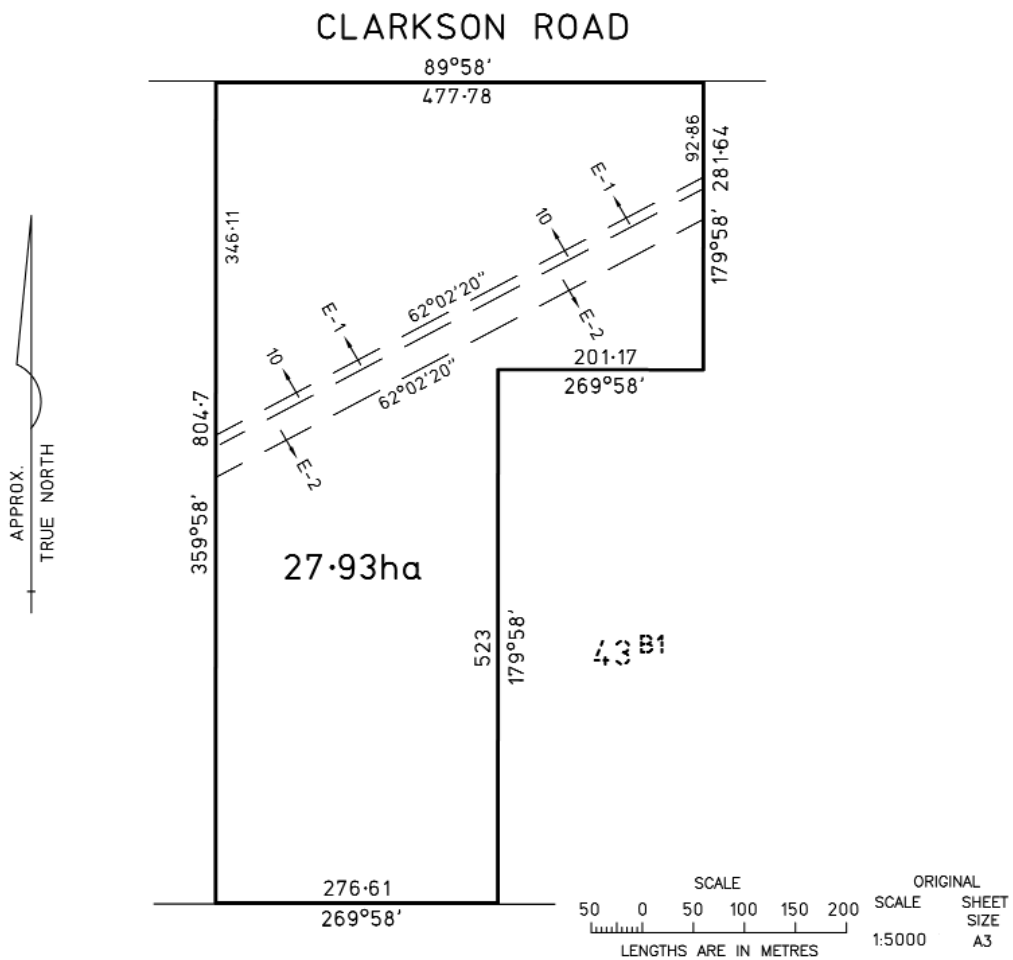

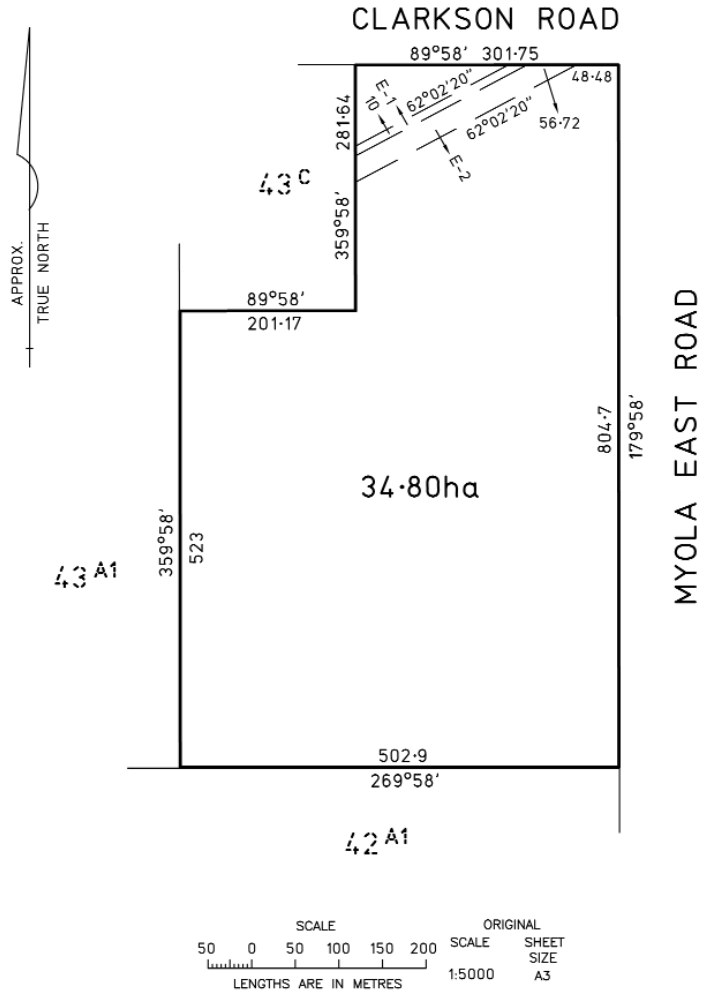

Published with the authority of COLIBAN REGION WATER AUTHORITY.  
Dated 30 January 2007

CHERYL FITZGERALD  
Corporate Secretary  
For and on behalf of  
COLIBAN REGION WATER AUTHORITY

**Land Acquisition and Compensation Act 1986**

**FORM 7**

Notice of Acquisition

Compulsory Acquisition of Interest in Land

To: Peter Henry McRobert as Registered Proprietor  
 To: Rabobank Australia Limited as Mortgagee under Mortgage No. AC962806W

COLIBAN REGION WATER AUTHORITY, ABN 96 549 082 360, of 37-45 Bridge Street, Bendigo 3550 declares that by this notice it acquires the following interest in the land described as: Easement for the purposes of a pipeline for water over that piece of land being portion of the land comprised and described in Certificate of Title Volume 10356, Folio 044 and being the area marked "E-1" on the Plan annexed hereto ("the land").

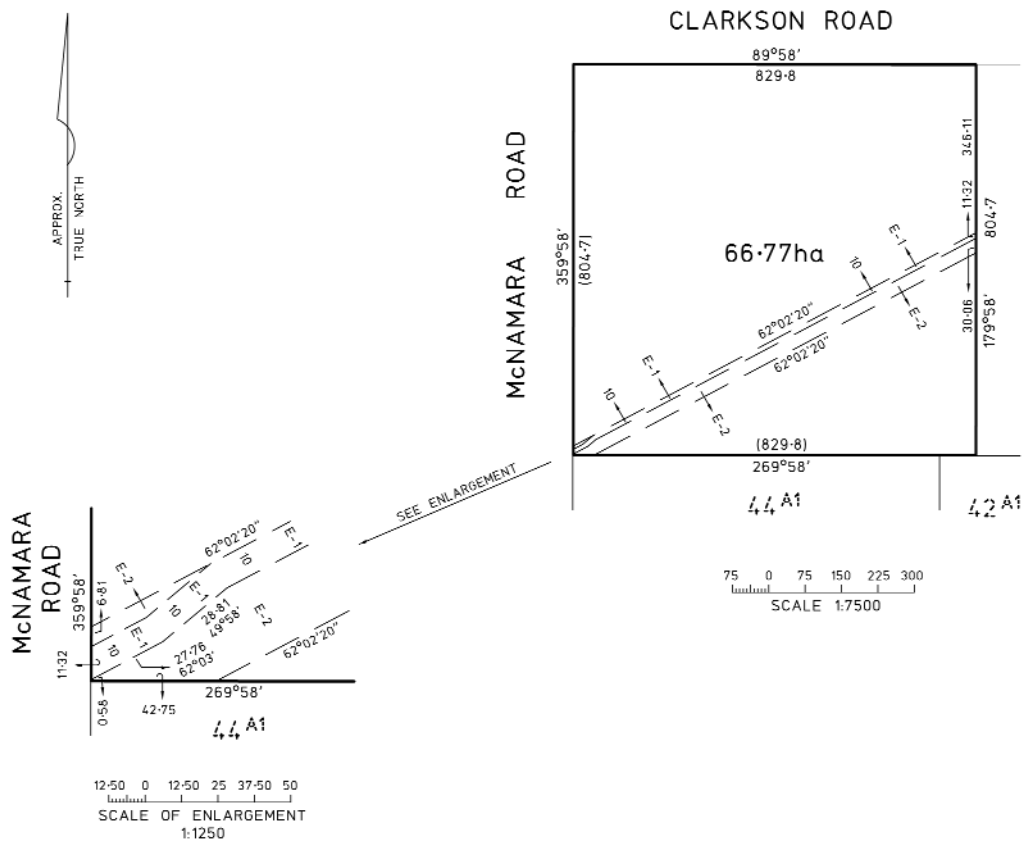

Published with the authority of COLIBAN REGION WATER AUTHORITY.  
 Dated 30 January 2007

CHERYL FITZGERALD  
 Corporate Secretary  
 For and on behalf of  
 COLIBAN REGION WATER AUTHORITY

**Land Acquisition and Compensation Act 1986**

**FORM 7**

**Notice of Acquisition**

**Compulsory Acquisition of Interest in Land**

To: Kevin Joseph Tuohey as Registered Proprietor  
 To: Jill Mary Tuohey as Registered Proprietor  
 To: Bank of Western Australia Limited as Mortgagee under Mortgage No. AC519837K

COLIBAN REGION WATER AUTHORITY, ABN 96 549 082 360, of 37-45 Bridge Street, Bendigo 3550 declares that by this notice it acquires the following interest in the land described as:  
 Easement for the purposes of a pipeline for water over that piece of land being portion of the land comprised and described in Certificate of Title Volume 09197, Folio 055 and being the area marked "E-1" on the Plan annexed hereto ("the land").

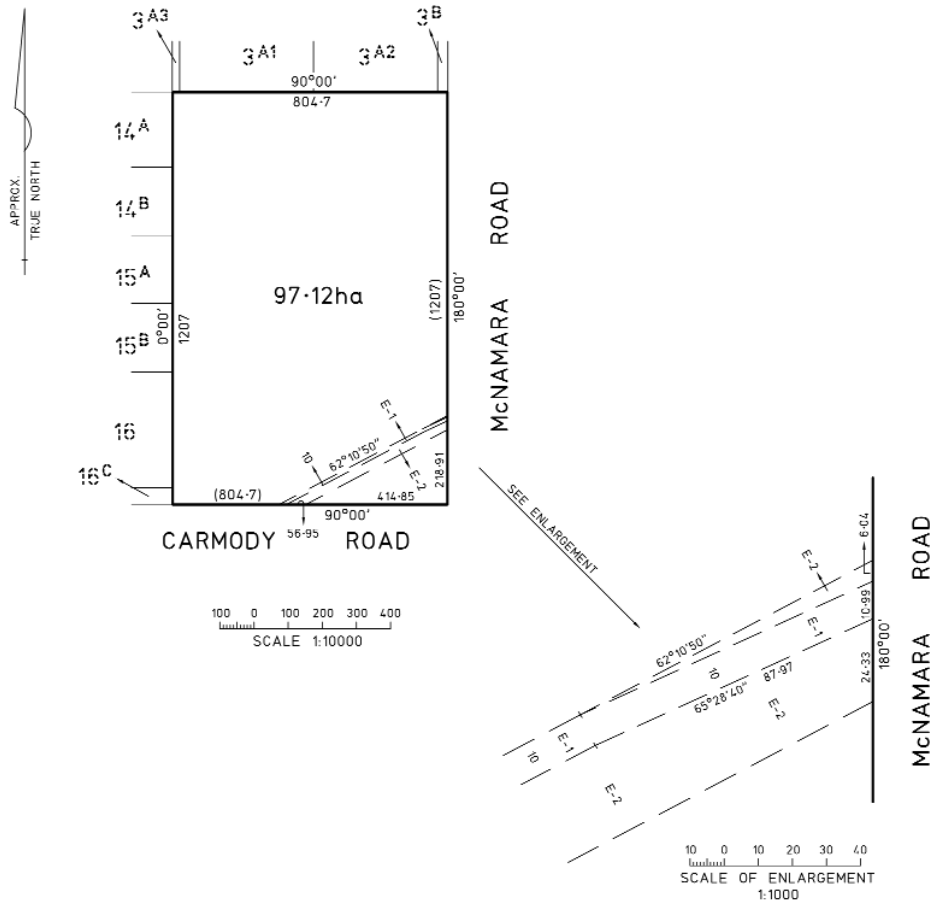

Published with the authority of COLIBAN REGION WATER AUTHORITY.  
 Dated 30 January 2007

CHERYL FITZGERALD  
 Corporate Secretary  
 For and on behalf of  
 COLIBAN REGION WATER AUTHORITY

**Land Acquisition and Compensation Act 1986**

FORM 7

Notice of Acquisition

Compulsory Acquisition of Interest in Land

- To: John Michael Burke as Registered Proprietor
- To: Alan Patrick Burke as Registered Proprietor
- To: Dorothy Margaret Burke as Registered Proprietor
- To: Richard Thomas Burke as Registered Proprietor

COLIBAN REGION WATER AUTHORITY, ABN 96 549 082 360, of 37-45 Bridge Street, Bendigo 3550 declares that by this notice it acquires the following interest in the land described as: Easement for the purposes of a pipeline for water over that piece of land being portion of the land comprised and described in Certificate of Title Volume 06100, Folio 980 and being the area marked "E-1" on the Plan annexed hereto ("the land").

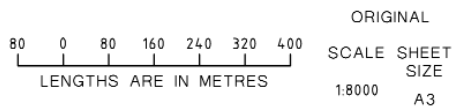
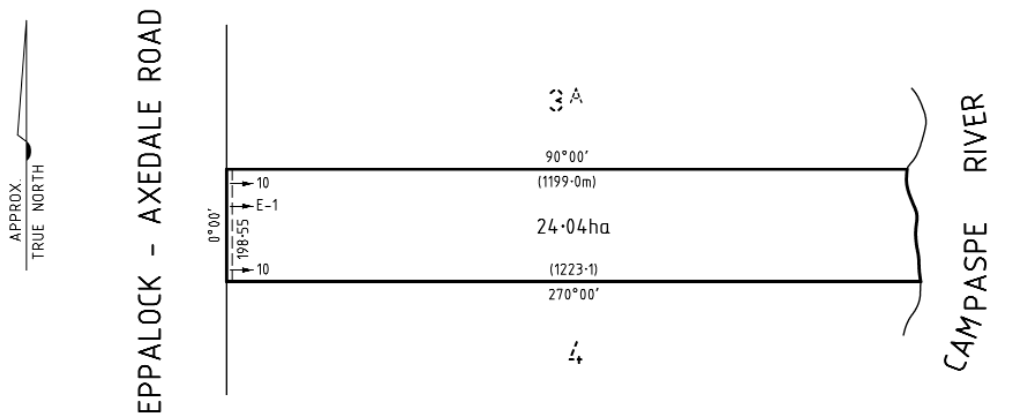

TITLE AREA:	24.04ha
EASEMENT AREA:	1986m <sup>2</sup>

Published with the authority of COLIBAN REGION WATER AUTHORITY.  
 Dated 30 January 2007

CHERYL FITZGERALD  
 Corporate Secretary  
 For and on behalf of  
 COLIBAN REGION WATER AUTHORITY

**Land Acquisition and Compensation Act 1986**

**FORM 7**

**Notice of Acquisition**

**Compulsory Acquisition of Interest in Land**

To: John Aloysius Colvin as Registered Proprietor

COLIBAN REGION WATER AUTHORITY, ABN 96 549 082 360, of 37-45 Bridge Street, Bendigo 3550 declares that by this notice it acquires the following interest in the land described as:

Easement for the purposes of a pipeline for water over that piece of land being portion of the land comprised and described in Certificates of Title Volume 10606, Folio 607, Volume 10606, Folio 608, and Volume 10606, Folio 606 and being the area marked "E-1" on the Plan annexed hereto ("the land").

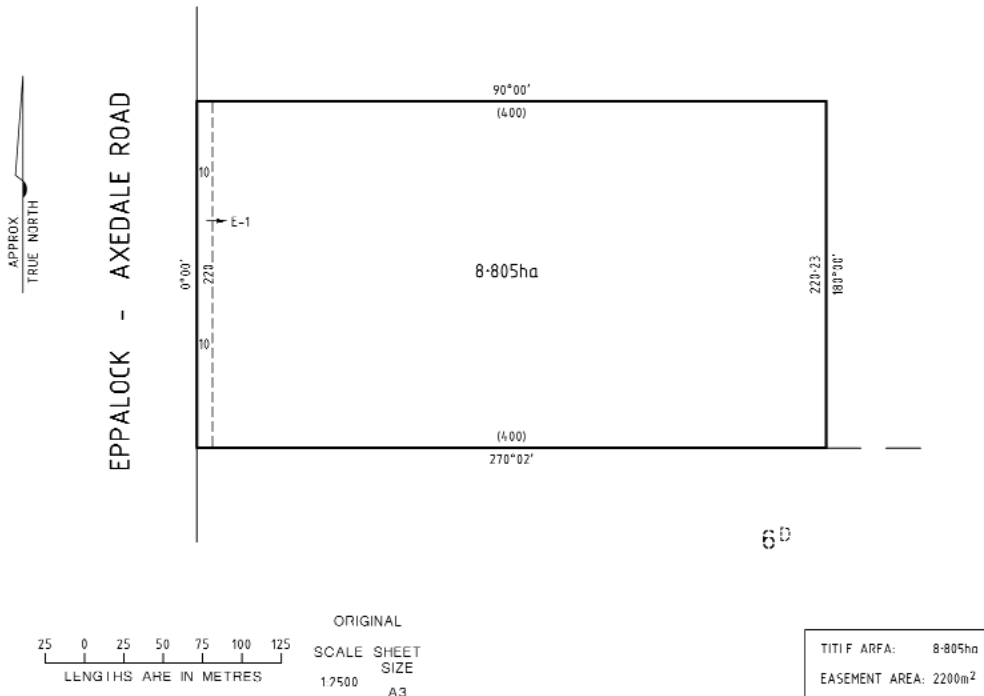

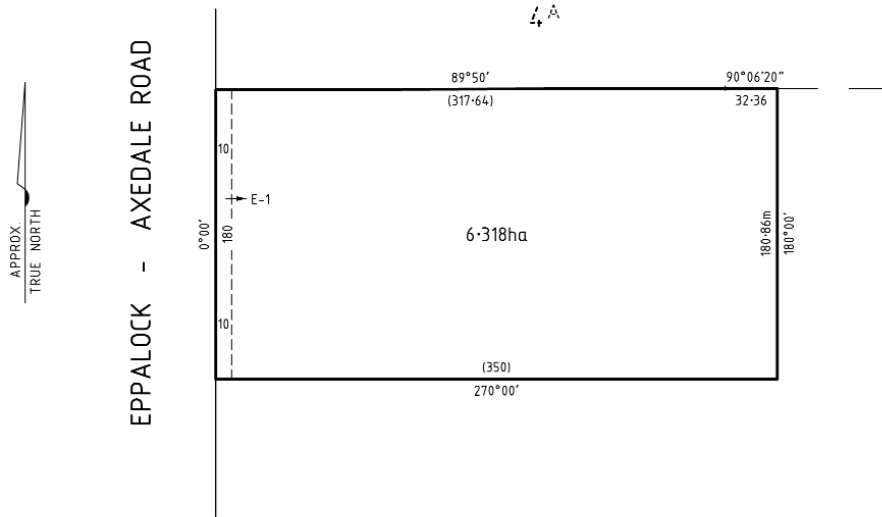

ORIGINAL  
SCALE SHEET  
SIZE  
1:2500  
A3

TITLE AREA: 6.318ha  
EASEMENT AREA: 1800m<sup>2</sup>

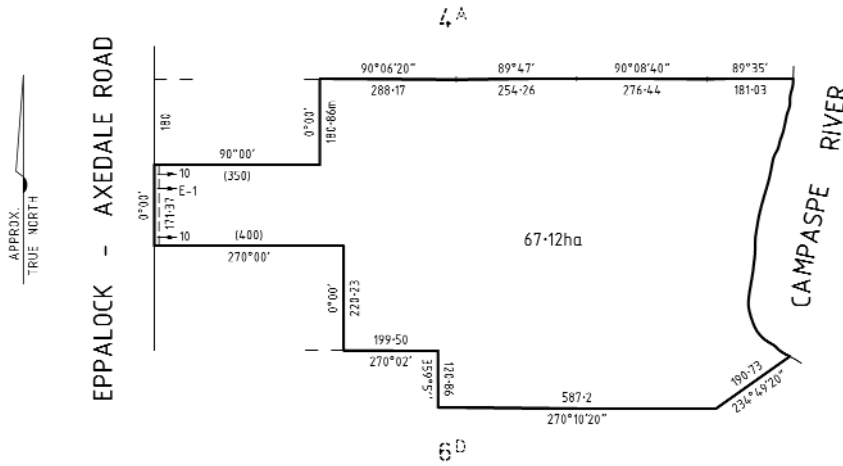

ORIGINAL  
SCALE SHEET  
SIZE  
1:8000  
A3

TITLE AREA: 67.12ha  
EASEMENT AREA: 1714m<sup>2</sup>

Published with the authority of COLIBAN REGION WATER AUTHORITY.  
Dated 30 January 2007

CHERYL FITZGERALD  
Corporate Secretary  
For and on behalf of  
COLIBAN REGION WATER AUTHORITY

**craftsmanpress**

The *Victoria Government Gazette* is published by The Craftsman Press Pty Ltd with the authority of the Government Printer for the State of Victoria

© State of Victoria 2007

This publication is copyright. No part may be reproduced by any process except in accordance with the provisions of the Copyright Act.

Address all enquiries to the Government Printer for the State of Victoria  
Level 2 1 Macarthur Street  
Melbourne 3002  
Victoria Australia

**How To Order**

	<b>Mail Order</b>	<b>Victoria Government Gazette</b> Level 1 520 Bourke Street Melbourne 3000 DX – 106 Melbourne
	<b>Telephone</b>	(03) 9642 5808
	<b>Fax</b>	(03) 9600 0478
	<b>email</b>	gazette@craftpress.com.au
	<b>Retail &amp; Mail Sales</b>	<b>Victoria Government Gazette</b> Level 1 520 Bourke Street Melbourne 3000
	<b>Telephone</b>	(03) 9642 5808
	<b>Fax</b>	(03) 9600 0478
	<b>Retail Sales</b>	<b>Information Victoria</b> 356 Collins Street Melbourne 3000
	<b>Telephone</b>	1300 366 356
	<b>Fax</b>	(03) 9603 9920

**Price Code B**