



# Victoria Government Gazette

By Authority of Victorian Government Printer

**No. G 14 Thursday 5 April 2007**

[www.gazette.vic.gov.au](http://www.gazette.vic.gov.au)

**GENERAL**

---

**TABLE OF PROVISIONS**

Private Advertisements	
Estates of Deceased Persons	
Bruce M. Cook & Associates	573
De Marco	573
Dwyer, Mahon & Robertson	573
Garden & Green	574
Goldsmiths	574
Pietrzak	574
Roberts Beckwith Partners	574
Sewells Larkins McCarthy	574
Tivey & Holland	575
Tragear & Associates Pty	575
Verna A. Cook	575
Government and Outer Budget Sector	
Agencies Notices	576
Orders in Council	606
Acts: Borrowing and Investment Powers;	
Cemeteries and Crematoria;	
Crown Land (Reserves);	
Land;	
State Aid to Religion Abolition;	
Fisheries	

---

**Advertisers Please Note**

As from 5 April 2007

The last Special Gazette was No. 78 dated 4 April 2007.

The last Periodical Gazette was No. 2 dated 27 October 2006.

---



---

**How To Submit Copy**

- See our webpage [www.craftpress.com.au](http://www.craftpress.com.au)
  - or contact our office on 9642 5808  
between 8.30 am and 5.30 pm Monday to Friday
- 

**Copies of recent Special Gazettes can now be viewed at the following display cabinet:**

- 1 Treasury Place, Melbourne (behind the Old Treasury Building)
-

---

**PUBLICATION OF THE VICTORIA GOVERNMENT GAZETTE (GENERAL)  
EASTER HOLIDAYS WEEK 2007**

**Please Note:**

The Victoria Government Gazette for Easter week (G15/07) will be published on **Thursday 12 April 2007.**

**Copy deadlines:**

Private Advertisements **9.30 am on Thursday 5 April 2007**

Government and Outer  
Budget Sector Agencies Notices **9.30 am on Tuesday 10 April 2007**

Where urgent gazettal is required after hours, arrangements should be made with the Government Gazette Officer on 0419 327 321.

JENNY NOAKES  
Government Gazette Officer

---

**PUBLICATION OF THE VICTORIA GOVERNMENT GAZETTE (GENERAL)  
ANZAC DAY WEEK 2007**

**Please Note:**

The Victoria Government Gazette for ANZAC week (G17/07) will be published on **Thursday 26 April 2007.**

**Copy deadlines:**

Private Advertisements **9.30 am on Friday 20 April 2007**

Government and Outer  
Budget Sector Agencies Notices **9.30 am on Monday 23 April 2007**

Where urgent gazettal is required after hours, arrangements should be made with the Government Gazette Officer on 0419 327 321.

JENNY NOAKES  
Government Gazette Officer

---

**VICTORIA GOVERNMENT GAZETTE**

**Subscribers and Advertisers**

Please note that the principal office of the Victoria Government Gazette, published and distributed by The Craftsman Press Pty Ltd, has changed from 28 July 2005.

**The new office and contact details are as follows:**

Victoria Government Gazette Office  
Level 1, 520 Bourke Street  
Melbourne, Victoria 3000

PO Box 1957  
Melbourne, Victoria 3001

DX 106 Melbourne

Telephone: (03) 9642 5808  
Fax: (03) 9600 0478  
Mobile (after hours): 0419 327 321

Email: [gazette@craftpress.com.au](mailto:gazette@craftpress.com.au)  
Website: [www.gazette.vic.gov.au](http://www.gazette.vic.gov.au)

JENNY NOAKES  
Government Gazette Officer

---

**PRIVATE ADVERTISEMENTS**

RE: Estate LYNETTE ANN JOHNSTONE, deceased.

Creditors, next-of-kin or others having claims in respect of the estate of Lynette Ann Johnstone, late of 1 Fitzgerald Road, Bullengarook, Victoria, gentlewoman, who died on 9 February 2007, are to send particulars of their claims to the personal representative/s care of the undermentioned solicitors by 6 June, 2007, after which date the personal representative/s will distribute the assets, having regard only to the claims of which they then had notice.

BRUCE M. COOK & ASSOCIATES,  
barristers & solicitors,  
Level 1, 114 William, Street, Melbourne 3000.

RE: Estate ROBERT LESLIE JOHNSTONE, deceased.

Creditors, next-of-kin or others having claims in respect of the estate of Robert Leslie Johnstone, late of 1 Fitzgerald Road, Bullengarook, Victoria, gentleman, who died on 5 December 2006, are to send particulars of their claims to the personal representative/s care of the undermentioned solicitors by 6 June 2007, after which date the personal representative/s will distribute the assets, having regard only to the claims of which they then had notice.

BRUCE M. COOK & ASSOCIATES,  
barristers & solicitors,  
Level 1, 114 William, Street, Melbourne 3000.

RE: Estate GLADYS WINIFRED MORRIS, deceased.

Creditors, next-of-kin or others having claims in respect of the estate of Gladys Winifred Morris, late of 35 Highfield Road, Canterbury, Victoria, retired, who died on 7 March 2007, are to send particulars of their claims to the personal representative/s care of the undermentioned solicitors by 6 June 2007, after which date the personal representative/s will distribute the assets, having regard only to the claims of which they then had notice.

BRUCE M. COOK & ASSOCIATES,  
barristers & solicitors,  
Level 1, 114 William, Street, Melbourne 3000.

Re: MARGARET EVELYN FEARNLEY, late of 24A Maude Avenue, Glenroy, Victoria, retired bookkeeper, deceased.

Creditors, next-of-kin and others having claims in respect of the estate of the deceased, who died on 8 December 2006, are required by the trustee, John Joseph Fearnley, to send particulars to the trustee care of the undermentioned solicitors within sixty days from the publication hereof, after which date the trustee may convey or distribute the assets, having regard only to the claims of which the trustee has notice.

DE MARCO, lawyers,  
794A Pascoe Vale Road, Glenroy 3046.

Re: Estate of HUGH JOHN FRANCIS BAILEY, deceased.

Creditors, next-of-kin or others having claims in respect of the estate of HUGH JOHN FRANCIS BAILEY, late of 584 Murray Valley Highway, Tyntynder, Victoria, storeman, deceased, who died on 31 January 2007, are to send particulars of their claim to the executors care of the undermentioned legal practitioners by 22 June 2007, after which date the executors will distribute the assets, having regard only to the claims of which they then have notice.

DWYER, MAHON & ROBERTSON,  
legal practitioners,  
Beveridge Dome,  
194-208 Beveridge Street, Swan Hill.

Re: Estate of DARREN GREVILLE McKENZIE.

Creditors, next-of-kin and others having claims in respect of the estate of Darren Greville McKenzie, late of 15 Wilkinson Street, Sea Lake, in the State of Victoria, patrolman, deceased, who died on 9 February 2007, are to send particulars of their claim to the executor care of the undermentioned legal practitioners by 14 June 2007, after which he will distribute the assets, having regard only to the claims of which he then has notice.

DWYER MAHON & ROBERTSON,  
legal practitioners,  
Beveridge Dome, 194-208 Beveridge Street,  
Swan Hill.

Re: JOSEPH CHARLES GROVES, deceased.

Creditors, next-of-kin and others having claims in respect of the estate of the deceased, who died on 20 November 2006, are required by the trustee, Barry Charles Groves, to send particulars to him care of the undersigned by 6 June 2007, after which date the trustee may convey or distribute the assets, having regard only to the claims of which he then has notice.

GARDEN & GREEN, solicitors,  
4 McCallum Street, Swan Hill 3585.

---

Re: OLIVE RITA THOMAS, deceased.

Creditors, next-of-kin and others having claims in respect of the estate of the deceased, who died on 28 August 2006, are required by the trustees, Paul Thomas Flanagan and Neville John Thomas, to send particulars to them care of the undersigned by 6 June 2007, after which date the trustees may convey or distribute the assets, having regard only to the claims of which they then have notice.

GARDEN & GREEN, lawyers,  
4 McCallum Street, Swan Hill 3585.

---

Re: GLADYS MARY WILLIAMS, deceased.

Creditors, next-of-kin and others having claims in respect of the estate of the deceased, who died on 9 February 2007, are required by the trustee, Diane Gardiner, to send particulars to her care of the undersigned by 6 June 2007, after which date the trustee may convey or distribute the assets, having regard only to the claims of which she then has notice.

GARDEN & GREEN, lawyers,  
4 McCallum Street, Swan Hill 3585.

---

STEVEN JOHN TULLOCH, late of 4 Rowan Street, Glenroy, in the State of Victoria.

Creditors, next-of-kin and others having claim in respect of the estate of the deceased, who died on 20 December 2007, are required by the executor, Robert Bruce Tulloch of 84 Cuthbert Street, Broadmeadows in the said State, to send particulars to him care of the undermentioned solicitors by 11 June 2007, after which date the executor may convey or distribute the assets, having regard only to the claims of which he then has notice.

GOLDSMITHS, barristers and solicitors,  
613 King Street, West Melbourne 3003.

---

Creditors, next-of-kin and others having claims in respect to the estate of BRUNO OZIMEK, also known as Bronislaw Ozimek, late of Villa Serena Nursing Home, Robina, in the State of Queensland, retired engineer, deceased, who died on 22 May 2006, are required to send particulars of such claims to the executors care of the undermentioned solicitors by 4 June 2007, after which date the executors will convey or distribute the assets, having regard only to the claims of which the executors then have notice.

PIETRZAK, solicitors,  
222 La Trobe Street, Melbourne.

---

Re: MILOS GVOZDANOVIC, late of Unit 80, 190 Osborne Drive, Mount Martha, but formerly of 51 Kent Street, Dromana, retired, deceased.

Creditors, next-of-kin and others having claims in respect of the estate of the deceased, who died on 22 June 2006, are required by the trustee, Milena Ursula Black, to send particulars of such claims to her in care of the undermentioned solicitors by 4 June 2007, after which date the trustee may convey or distribute the assets, having regard only to the claims of which the trustee has notice.

ROBERTS BECKWITH PARTNERS, lawyers,  
16 Blamey Place, Mornington 3931.

---

Re: JOHN GERARD SPROULES, late of 1529 Princes Highway, Pirron Yallock, Victoria, disability services worker, deceased.

Creditors, next-of-kin and others having claims in respect of the estate of the deceased, who died on 26 January 2007, are required by the deceased's personal representative, Esperanza Joy Sproules, to send particulars to her care of the undermentioned solicitors by 4 June 2007, after which date the personal representative may convey or distribute the assets, having regard only to the claims of which she then has notice.

SEWELLS LARKINS MCCARTHY, lawyers,  
119 Murray Street, Colac.

---

ROBERT GERRAND McCLURE, late of 15 Main Street, Stawell, deceased.

Creditors, next-of-kin and others having claims in respect of the estate of the deceased, who died on 19 August 2006, are required by the administrator, Jillian Anne Prins, care of the undermentioned solicitors to send particulars to them by 5 June 2007, after which date the administrator may convey or distribute the assets, having regard only to the claims of which she then has notice.

TIVEY & HOLLAND, solicitors,  
97 Barkly Street, Ararat.

---

Re: ARTHUR LESLIE RUSSELL, late of Centennial Lodge Nursing Home, 13 Lewis Road, Wantirna, Victoria, deceased.

Creditors, next-of-kin and others having claims in respect of the estate of the deceased, who died 15 December 2006, are required by the trustee, Kevin Stanley Tragear, solicitor, of 1/23 Melrose Street, Sandringham, Victoria, to send particulars to him care of the undermentioned solicitors by 11 June 2007, after which date the trustee may convey and distribute the assets, having regard only to the claims of which he has notice.

TRAGEAR & ASSOCIATES PTY, solicitors,  
1/23 Melrose Street, Sandringham 3191.

---

NORMAN CHARLES TIMS, deceased.

Creditors, next-of-kin and others having claims in respect of the estate of NORMAN CHARLES TIMS, late of Unit 5, 36 The Esplanade, Brighton, Victoria, retired company director, deceased, who died on 22 January 2007, are required to send particulars of their claims to the executors care of the undermentioned solicitors by 12 June 2007, after which date the executors will proceed to distribute the assets, having regard only to the claims of which they shall then have had notice.

VERNA A. COOK, solicitor,  
5/8 St Andrews Street, Brighton 3186.

---

**GOVERNMENT AND OUTER BUDGET  
SECTOR AGENCIES NOTICES**



Mildura Rural City Council

Road Discontinuance of a Section of Acacia Drive Mildura

Under Section 206 and Schedule 10, Clause 3 of the **Local Government Act 1989**, the Mildura Rural City Council under delegation formed the opinion that the above section of road (refer plan below) is not reasonably required for public use and resolved to discontinue the section of road with the sale and transfer of land to the adjoining property owners.

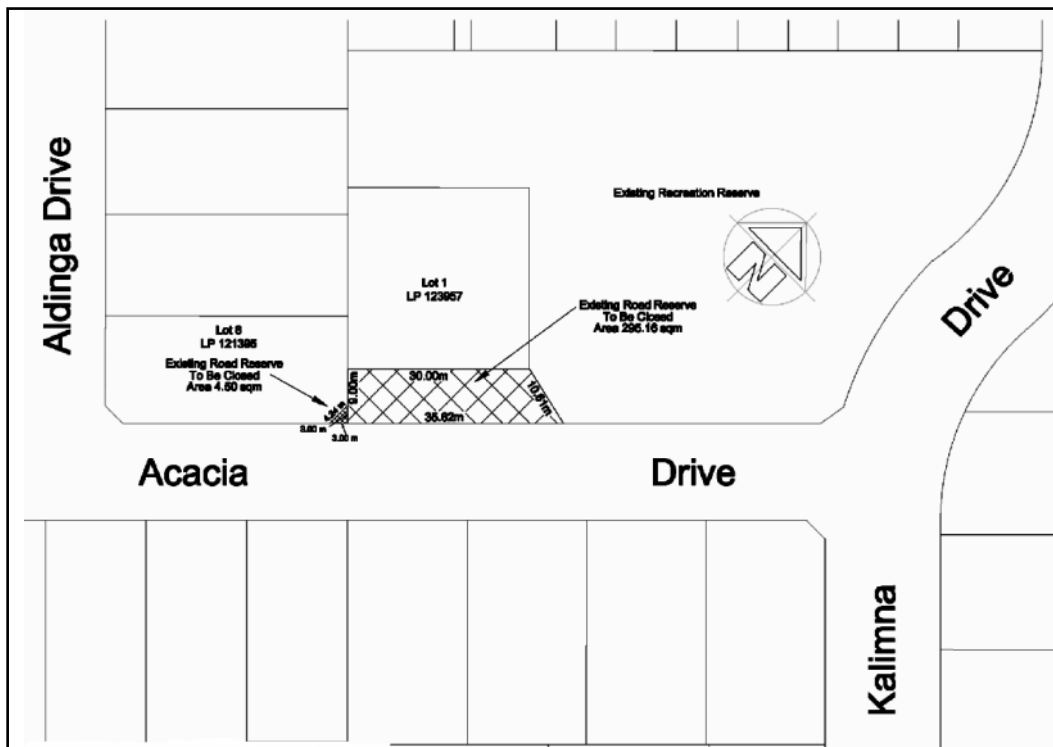

PHIL PEARCE  
Chief Executive Officer  
Mildura Rural City Council





Road Discontinuance

East, West and South of Crown Allotment 24A Parish Jung Jung

At its meeting on 13 March 2007 Council acting under clause 3 of Schedule 10 of the **Local Government Act 1989**, Yarriambiack Shire have resolved to discontinue the road as shown attached. As it is not reasonably required as a road for public use, and that the road be licensed for agricultural purposes.

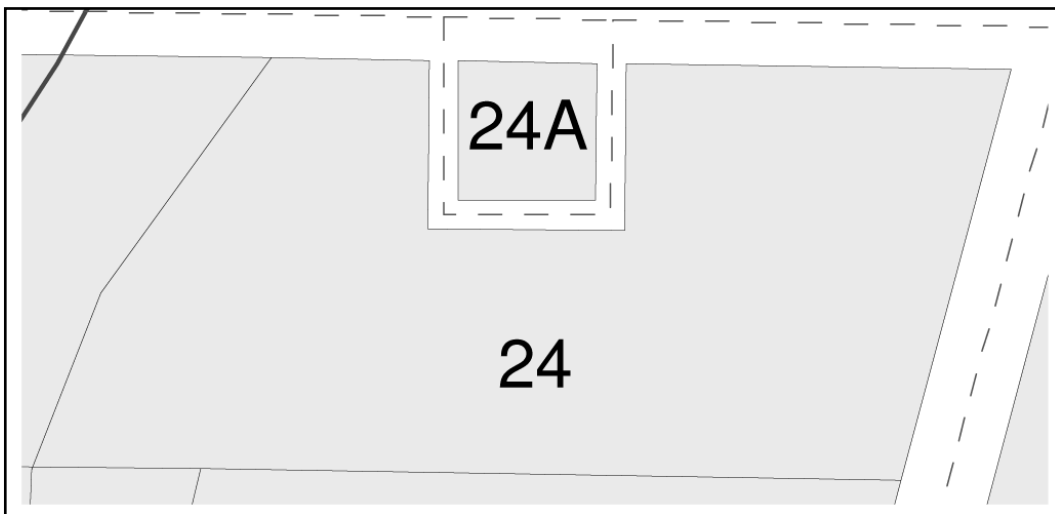

RAY CAMPLING  
Chief Executive Officer



Notice of Adoption of  
New Meeting Procedure Local Law

Notice is hereby given that the City of Boroondara, at its meeting held on 26 March 2007, resolved to adopt its new Meeting Procedure Local Law, entitled Meeting Procedure Local Law, which repeals the existing Meeting Procedure Local Law No. 3a in its entirety and replaces it with this Local Law titled Meeting Procedure Local Law.

The purpose of the Local Law is to:

- provide for the election of the Mayor;
- regulate the use of the common seal;
- prohibit unauthorised use of the common seal or any device resembling the common seal; and
- provide for the procedures governing the conduct of Council meetings and Special Committee Meetings.

The general purport of the Meeting Procedure Local Law will be to:

- revoke the existing Meeting Procedure Local Law No. 3a in its entirety;
- establish a law which will govern order of business, rules of debate, meeting procedure, public access and conduct of meetings; and
- improve and formalise governance processes when dealing with public submissions and presentations at Special Committee meetings.

This Local Law will come into effect from 6 April 2007.

Copies of the new Local Law are available at [www.boroondara.vic.gov.au](http://www.boroondara.vic.gov.au) or at the Council Office at 8 Inglesby Road, Camberwell during business hours.

PETER JOHNSTONE  
Chief Executive Officer



**Public Holidays Act 1993**

Pursuant to Section 7 of the **Public Holidays Act 1993**, the Hindmarsh Shire Council has declared the following days as Public Half Day Holidays commencing at 12 noon for the following districts:

Rainbow – Tuesday 16 October 2007 to mark the Rainbow Agricultural & Pastoral Society Show;

Jeparit – Wednesday 17 October 2007 to mark the Jeparit Agricultural & Pastoral Society Show; and

Nhill – Thursday 18 October 2007 to mark the Nhill Agricultural & Pastoral Society Show.

JOHN HICKS  
Chief Executive Officer



**Local Government Act 1989**  
GENERAL AMENDMENT  
LOCAL LAW 2007

At Moyné Shire Council's Ordinary Meeting held on the 27 March 2007, Council, under Section 119 of the **Local Government Act 1989**, resolved to make General Amendment Local Law 2007. The amending Local Law comes into operation on the 28 March 2007 and amends Council's Local Law (General) No. 3 of 2005.

The purpose of General Amendment Local Law 2007 is to provide controls over parked vehicles being used for advertising.

The amending Local Law will control the parking of any vehicle with advertising on it in such a way to be used to direct persons to a business address or function.

A copy of the Local Law may be inspected at or obtained from Council offices in Port Fairy and is available from Council's website at [www.moyné.vic.gov.au/publicnotices](http://www.moyné.vic.gov.au/publicnotices).

GRAHAM SHIELL  
Chief Executive Officer



**Northern Grampians**  
*Shire Council*

Local Law No. 10 – Meeting Procedure

Notice is hereby given that at a meeting of the Northern Grampians Shire Council held on 22 March 2007, Council made Local Law No. 10 pursuant to the **Local Government Act 1989**.

The purpose of the Local Law is to:

- regulate and control the procedures governing the conduct of meetings including:
  - the notice required for meetings;
  - the keeping of minutes; and
- regulate and control the election of Mayor and the Chairperson of any Special Committees.

The general purport of the Local Law is to provide a mechanism to facilitate the good government of the Council through its formal meeting procedures, outlining the manner in which business is to be considered and the various requirements placed on Council and Committee members in that process.

A copy of the Local Law may be inspected at or obtained from Council offices in Stawell and St Arnaud during office hours.

GLEN DAVIS  
Chief Executive Officer



#### Notice of Intention to Make a Local Law

Notice is hereby given pursuant to Section 119 of the **Local Government Act 1989** that Swan Hill Rural City Council at its Ordinary Meeting held on 20 February 2007 resolved to intend to make a new Local Law entitled Local Law No. 2 – Community.

The purpose and general purport of the proposed Local Law No. 2 is to:

- a. provide for the peace, order and good government of the municipal district;
- b. provide a safe and healthy environment, in which the residents of the municipal district enjoy a quality of life that meets the general expectations of the community;
- c. control and regulate emissions to the air in order to improve the amenity, environment and quality of life in the municipal district;
- d. ensure that the public can properly use and enjoy public reserves by regulating activities and behaviour in public reserves;

- e. prohibit, regulate and control the consumption of alcohol in designated areas within the municipal district;
- f. manage, regulate and control the different uses to which streets, roads, footpaths and Council land can be put so as to ensure that there is a proper balance between private uses and the need to maintain freedom of movement for the public; and
- g. manage, regulate and control the keeping of animals and birds.

The new law integrates and codifies the previous Local Laws:

- a. No. 2 Consumption of Liquor in Public Places;
- b. No. 5 Keeping of Animals, Birds and Poultry; and
- c. No. 6 Streets and Roads

which it is proposed that on adoption of Local Law No. 2 – Community, shall be revoked.

The Local Law No. 2 also incorporates by reference:

- a. the Waste Code of Practice, which has the objective of providing an environment where activity related to waste and recycling complement the safety, & amenity of the community.
- b. Building and Works Code of Practice, which has the objective of providing an environment where activity on and related to building sites and building works complement the safety and amenity of the public and the community.
- c. Trading Code of Practice which has the objective of providing for the peace, order, well being and safety of people and amenity of public places in the municipality
- d. Livestock Code of Practice which has the objective of:
  - i. ensuring safety of the public, farmers and stock on Council controlled roads;
  - ii. aims to prevent damage to the road structure and environs; and
  - iii. promotes the conservation of flora and fauna on roadside land.

In accordance with Section 223 of the **Local Government Act 1989**, written submissions may be made by any person affected by the proposed Local Law. Any person making a submission may request to be heard in support of their submission at a meeting of the Council. Where a person wishes to be heard by Council they must advise of such in their written submission. Submissions must be received by Council within 28 days of the publication of this notice and should be addressed to the Chief Executive Officer, Swan Hill Rural City Council, 45 Splatt Street, Swan Hill 3585.

A copy of the proposed Local Law and the Codes of Practice may be obtained free of charge from Swan Hill Rural City Council Customer Service Centres at 45 Splatt Street, Swan Hill and 68–72 Herbert Street, Robinvale during office hours or from the Council's website [www.swanhill.vic.gov.au](http://www.swanhill.vic.gov.au)

DENNIS HOVENDEN  
Chief Executive Officer



Community Local Law No. 2 2006 –  
Amending Local Law

Notice is hereby given that Whitehorse City Council at its meeting of 19 March 2007 made Community (Amendment) Local Law No. 2 – Amending Local Law.

The purpose of this Local Law is to amend various clauses of the Whitehorse City Council Community Local Law No. 1 2006.

Copies of the Local Law and the accompanying policy document are available for inspection and can be obtained from the Whitehorse City Council Service Centres at 379–397 Whitehorse Road, Nunawading; Box Hill Town Hall, Maroondah Highway, Box Hill; and Shop 130, Forest Hill Chase, Canterbury Road, Forest Hill, by phoning 9262 6333 or via our website at [www.whitehorse.vic.gov.au](http://www.whitehorse.vic.gov.au).

The Local Law will commence on 15 April 2007.

NOELENE DUFF  
Chief Executive Officer



**Planning and Environment Act 1987**  
BASS COAST PLANNING SCHEME  
Notice of Preparation of Amendment  
Amendment C71  
Authorisation A0630

The Bass Coast Shire Council has prepared Amendment C71 to the Bass Coast Planning Scheme.

In accordance with section 9(2) of the **Planning and Environment Act 1987**, the Minister for Planning authorised the Bass Coast Shire Council as planning authority to prepare the Amendment.

The land affected by the Amendment is 7 Mortimer Street, Wonthaggi.

The Amendment proposes to rezone the land from Public Use Zone Schedule 6 to Residential 1 Zone.

You may inspect the Amendment, any documents that support the Amendment and the explanatory report about the Amendment at the following locations: Bass Coast Shire Council, 76 McBride Avenue, Wonthaggi; Department of Sustainability and Environment, Gippsland Regional Office, 71 Hotham Street, Traralgon; and Planning Information Centre, Ground Floor, 8 Nicholson Street, East Melbourne.

This can be done during office hours and is free of charge.

Any person who may be affected by the Amendment may make a submission to the planning authority.

The closing date for submissions is 7 May 2007. A submission must be sent to the Strategic Planner, Bass Coast Shire Council, 76 McBride Avenue, Wonthaggi 3995.



**Planning and Environment Act 1987**  
BASS COAST PLANNING SCHEME  
Corrigendum  
Amendment C57

In Government Gazette No. G13, dated 29 March 2007 on page 538 and 539, under the notice headed "Bass Coast Planning Scheme,

Amendment C57”, the closing date for submissions was incorrect. The first sentence of the final paragraph should read:

“The closing date for all submissions is Tuesday 3 May 2007.

ALLAN BAWDEN  
Chief Executive Officer  
Bass Coast Shire Council

---

**Planning and Environment Act 1987**

**BAW BAW PLANNING SCHEME**

Notice of Preparation of Amendment

Amendment C46

Authorisation A0617

The Baw Baw Shire Council has prepared Amendment C46 to the Baw Baw Planning Scheme.

In accordance with section 9(2) of the **Planning and Environment Act 1987**, the Minister for Planning authorised the Baw Baw Council as planning authority to prepare the Amendment. The Minister also authorised the Baw Baw Shire Council to approve the Amendment under section 35B of the Act.

The land affected by the Amendment is located on the southern side of Shillinglaw Road, Drouin being:

- Land in Gardner & Holman Road, Drouin being CA 33 Section B, Township of Drouin, Parish of Drouin West
- 129 Gardner & Holman Road, Drouin, being CA 34 Section B, Township of Drouin, Parish of Drouin West
- 165 Settlement Road, Drouin, being Lot 2 LP 148356X Parish of Drouin West
- 117 Shillinglaw Road, Drouin, being Lot 1 LP 203331L Parish of Drouin West
- 111 Shillinglaw Road, Drouin, being Lot 2 LP 203331L Parish of Drouin West
- 95 Shillinglaw Road, Drouin, being CA's 43 & 44 Sec B Township of Drouin, Parish of Drouin West
- 75 Shillinglaw Road, Drouin, being CA 44 Sec B, Township of Drouin, Parish of Drouin West
- 55 Shillinglaw Road, Drouin, being Lot 1 LP 138746 Parish of Drouin West

- 45 Shillinglaw Road, Drouin, being Lot 2 LP 138746 Parish of Drouin West.

The Amendment proposes to:

- rezone the subject land from Industrial 1 Zone to Rural Living Zone 2.
- Rename the existing Rural Living Zone on the planning scheme maps to Rural Living Zone 1.
- Rename the existing schedule to clause 35.03 – Rural Living Zone to schedule 1 and introduce a new schedule 2 to the zone.
- Delete Development Plan Overlay 4 from the subject land.

You may inspect the Amendment, any documents that support the Amendment, the explanatory report about the Amendment, the planning permit application and draft permit conditions at the following locations: at the offices of the Baw Baw Shire Council, 61 Smith Street, Warragul; Young Street, Drouin and the Baw Baw Technology Centre, Princes Highway, Trafalgar; at the Department of Sustainability and Environment, Gippsland Regional Office, 71 Hotham Street, Traralgon; and at the Department of Sustainability and Environment, Planning Information Centre, Ground Floor, 8 Nicholson Street, East Melbourne.

This can be done during office hours and is free of charge.

Any person who may be affected by the Amendment may make a submission to the planning authority.

The closing date for submissions is 7 May 2007. A submission must be sent to the Baw Baw Shire Council, PO Box 304, Warragul 3820.

GLENN PATTERSON  
Chief Executive Officer  
Baw Baw Shire Council

---

**Planning and Environment Act 1987**

**DAREBIN PLANNING SCHEME**

Notice of Preparation of Amendment

Amendment C74

Authorisation A0618

The Darebin City Council has prepared Amendment C74 to the Darebin Planning Scheme.

In accordance with section 9(2) of the **Planning and Environment Act 1987**, the Minister for Planning authorised the Darebin City Council as planning authority to prepare the Amendment. The Minister also authorised the Darebin City Council to approve the Amendment under section 35B of the Act.

The land affected by the Amendment is 110–118 Chifley Drive, Preston.

The Amendment proposes to:

- rezone the land from the Industrial 3 Zone to the Business 4 Zone; and
- apply an Environmental Audit Overlay to the land.

You may inspect the Amendment, any documents that support the Amendment and the explanatory report about the Amendment at the following locations: at the office of the planning authority, Darebin City Council, Strategic Planning Unit, First Floor, 274 Gower Street, Preston; and at the Department of Sustainability and Environment, Planning Information Centre, Ground Floor, 8 Nicholson Street, East Melbourne.

This can be done during office hours and is free of charge.

Any person who may be affected by the Amendment may make a submission to the planning authority.

The closing date for submissions is 15 May 2007. A submission must be sent to the Co-ordinator Strategic Planning, City of Darebin, PO Box 91, Preston, Victoria 3072.

MICHAEL ULBRICK  
Chief Executive Officer

**Planning and Environment Act 1987**  
MAROONDAH PLANNING SCHEME  
Notice of Preparation of Amendment  
Amendment C56  
Authorisation A0469

The Maroondah City Council has prepared Amendment C56 to the Maroondah Planning Scheme.

In accordance with section 9(2) of the **Planning and Environment Act 1987**, the Minister for Planning authorised the Maroondah City Council as planning authority to prepare the Amendment.

The land affected by the Amendment is the land identified within the Croydon Town Centre Structure Plan 2006.

The Amendment proposes to:

1. Amend the Municipal Strategic Statement to incorporate the aims of the Croydon Town Centre Structure Plan, 2006, in the following clauses:
  - a. Clause 21.02 – Municipal Profile
  - b. Clause 21.03 – Maroondah Vision – The Strategic Framework
  - c. Clause 21.08 – Residential Land Use
  - d. Clause 21.09 – Retail and Commercial Activity
  - e. Clause 21.10 – Industrial Land Use
  - f. Clause 21.11 – Environment
  - g. Clause 21.12 – Protection of Ridgelines
2. Amend the Local Planning Policies to incorporate the aims of the Croydon Town Centre Structure Plan, 2006, in the following clauses:
  - a. 22.03 – Maroondah Residential Neighbourhood Character Policy
  - b. 22.06 – Retail and Commercial Development Policy
  - c. 22.09 – Industrial Urban Design And Development Policy
  - d. 22.10 – Hewish Road Mixed Use Zone Policy
  - e. 22.13 – Croydon Town Centre Residential Development Policy
3. Delete the Design and Development Overlay – Schedule 8.
4. Apply a Design and Development Overlay – Schedule 9 to include permanent height controls over the Croydon Town Centre in accordance with the Croydon Town Centre Structure Plan, 2006.
5. Minor administrative edits to the Significant Landscape Overlay – Schedule 3 and Schedule 4 for consistency.

You may inspect the Amendment, any documents that support the Amendment and the explanatory report about the Amendment at the following locations: at the office of the planning authority, Maroondah City Council: City Offices Service Centre, Braeside Avenue, Ringwood; Eastland Service Centre, Level 2,

Shop G104, Eastland Shopping Centre, Ringwood; Civic Square Service Centre, Civic Square, Croydon; Croydon Library, Civic Square, Croydon; Ringwood Library, Ringwood Plaza, Ringwood; and at the Department of Sustainability and Environment, Planning Information Centre, Ground Floor, 8 Nicholson Street, East Melbourne.

This can be done during office hours and is free of charge.

Any person who may be affected by the Amendment may make a submission to the planning authority.

The closing date for submissions is 18 May 2007. A submission must be sent in writing to Trevor Welsh, Director City Development, PO Box 156, Ringwood 3134.

### **Planning and Environment Act 1987**

#### **SURF COAST PLANNING SCHEME**

##### **Notice of Preparation of Amendment**

##### **Amendment C39**

##### **Authorisation No. A625**

The Surf Coast Shire Council has prepared Amendment C39 to the Surf Coast Planning Scheme. In accordance with section 9(2) of the **Planning and Environment Act 1987**, the Minister for Planning authorised the Surf Coast Shire Council as planning authority to prepare the Amendment.

The land affected by the Amendment is all land within the township of Winchelsea and hinterland.

The Amendment proposes to:

- update the 'Rural Residential Strategy' at clause 21.09 of the Municipal Strategic Statement.
- Refine the 'Winchelsea Strategy' at clause 21.14 of the Municipal Strategic Statement.
- Rezone land at 30 and 32–34 Main Street and land on Palmer Street to Business 1 Zone.
- Amend the Schedule to the Low Density Residential Zone to include minimum lot sizes for the existing estates on the boundaries of the town.
- Apply the Environmental Significance Overlay – Schedule 1 or Vegetation Protection

Overlay – Schedule 1 to environmental assets identified within and surrounding the Winchelsea township.

- Introduce a new Significant Landscape Overlay – Schedule to private land that adjoins the Barwon River reserve within the settlement boundary of Winchelsea.
- Introduce a new Environmental Audit Overlay to the former night soil depot on land at 235 Austin Street, Winchelsea.

You may inspect the Amendment, any documents that support the Amendment and the explanatory report about the Amendment at the following locations: at the office of the planning authority, Surf Coast Shire, 25 Grossmans Road, Torquay; at the Department of Sustainability and Environment South West Regional Office, Level 4, State Government Offices, corner of Little Malop and Fenwick Streets, Geelong; at the Department of Sustainability and Environment, Planning Information Centre, Ground Floor, 8 Nicholson Street, East Melbourne; and at Winchelsea Community House, 28 Hesse Street, Winchelsea (9.00 am to 1.00 pm Monday–Friday excluding school holidays).

This can be done during office hours and is free of charge.

Any person who may be affected by the Amendment may make a submission to the planning authority. The closing date for submissions is Monday 7 May 2007. Submissions must be sent to the Co-ordinator Strategic Planning, Surf Coast Shire, PO Box 350, Torquay, Vic. 3228.

MARK HARWOOD

Co-ordinator Strategic Planning

### **STATE TRUSTEES LIMITED**

ACN 064 593 148

Section 79

Notice is hereby given that State Trustees Limited, ACN 064 593 148, intends administering the estates of:–

ABIGAIL ANASTASIA CONNELL, late of Wesley Heights Aged Care, 27 Birkley Road, Manly, New South Wales, pensioner, deceased, who died on 4 February 2007 leaving a will dated 17 March 1992.

WILLIAM JOHN CUSHION, late of 23 Heather Street, Hamlyn Heights, Victoria, pensioner, deceased, who died on 2 October 2006 leaving a will dated 28 May 1987.

KELVA JUNE McKINNON, late of 15 Kiata Drive, Mildura, Victoria, deceased intestate, who died on 24 October 2006.

Creditors, next-of-kin and others having claims against the abovementioned estates are required pursuant to Section 33 of the **Trustee Act 1958** to send particulars of their claims against the abovementioned estates to State Trustees Limited, 168 Exhibition Street, Melbourne, Victoria, on or before 6 June 2007, after which date State Trustees Limited, ACN 064 593 148, may convey or distribute the assets of the abovementioned estates, having regard only to the claims of which it then has notice.

Creditors, next-of-kin and others having claims against the estate of any of the undermentioned deceased persons are required to send particulars of their claims to State Trustees Limited, ABN 68 064 593 148, 168 Exhibition Street, Melbourne, Victoria 3000, the personal representative, on or before 6 June 2007, after which date State Trustees Limited may convey or distribute the assets, having regard only to the claims of which State Trustees Limited then has notice.

AYLETT, Lorraine Merle, late of Flat 2, 136 St Georges Road, Northcote, Victoria 3070, retired, and who died on 25 October 2006.

BARNARD, Fiona Lee, late of PO Box 285, Colanda Training Centre, Martin Unit, Colac, Victoria 3250, who died on 1 November 2006.

DEAN, Patricia Mary, late of 11 Baxter Street, Coburg, Victoria 3058, pensioner, and who died on 5 February 2007.

DOWN, Joyce Isobel, late of Colanda Training Centre, 120 Forest Street, Colac, Victoria 3250, who died on 17 November 2006.

EVANS, Vernon Lyle, late of 28 Kwinana Street, Glen Waverley, Victoria 3150, who died on 22 December 2006.

GIBBS, Joan Margaret, late of Colbran Lodge Nursing Home, 45 Moubray Street, Melbourne, Victoria 3000, pensioner, and who died on 10 October 2006.

HARDINGE, Mavis Clarice, late of Homestead Private Nursing Home, 22 Homestead Avenue, Wallington, Victoria 3221, who died on 7 November 2006.

LOVE, Eileen Anne, late of Noel Miller Centre Nursing Home, 9–15 Kent Street, Glen Iris, Victoria 3146, pensioner, and who died on 6 January 2007.

Dated 28 March 2007

MARY AMERENA  
Manager  
Executor and Trustee Services

Creditors, next-of-kin and others having claims against the estate of any of the undermentioned deceased persons are required to send particulars of their claims to State Trustees Limited, ABN 68 064 593 148, 168 Exhibition Street, Melbourne, Victoria 3000, the personal representative, on or before 5 June 2007, after which date State Trustees Limited may convey or distribute the assets, having regard only to the claims of which State Trustees Limited then has notice.

FAUVEL, Lesley Merna, late of 90 Rathmines Road, Hawthorn East, Victoria 3123, home duties and who died on 6 December 2006.

GRAYDON, William George Eustace, late of 21 Jacksons Hill Road, Selby Victoria 3159, retired, and who died on 7 January 2007.

HASSETT, James Timothy, late of 72 Bridge Street, Northcote, Victoria 3070, and who died on 25 January 2007.

LYNCH, Edna June, formerly of 11 Wymlet Street, Fawkner, Victoria 3060, but late of Emily Lenny Aged Care, 24 Sutherland Street, Coburg, Victoria 3058, who died on 11 January 2007.

MEAD, Grace Myrtle, late of Room 20 Sheridan Hall, 16 Castlebar Road, Malvern East, Victoria 3145, retired, and who died on 24 December 2006.

MUMFORD, Lindsay, late of 34 William Street, Preston, Victoria 3072, retired, and who died on 2 February 2007.

PESEVSKI, Dusan, late of Unit 3/68 Dundas Street, Northcote, Victoria 3070, pensioner, and who died on 3 May 2006.



SLOAN, Colin Andrew, formerly of 43 Ebdon Street, Heathcote, Victoria 3523, but late of McIvor Health and Community Services, 39 Hospital Street, Heathcote, Victoria 3523, and who died on 16 March 2007.

Dated 27 March 2007

MARY AMERENA  
Manager  
Executor and Trustee Services

---

Creditors, next-of-kin and others having claims against the estate of any of the undermentioned deceased persons are required to send particulars of their claims to State Trustees Limited, ABN 68 064 593 148, 168 Exhibition Street, Melbourne, Victoria 3000, the personal representative, on or before 11 June 2007, after which date State Trustees Limited may convey or distribute the assets having regard only to the claims of which State Trustees Limited then has notice.

HANNAH, Olive Edna, late of Mentone & District Private Nursing Home, 7 Collins Street, Mentone, Victoria 3194, who died on 24 March 2007.

JAROSZEWSKI, George Patrick, late of 1 Seacombe Street, Fawkner, Victoria 3060, moulder, and who died on 5 November 2006.

YOUNG, Myrtle Otilie, late of 145 Ludstone Street, Hampton, Victoria 3188, pensioner, and who died on 18 December 2006.

WEBBER, Anne Patricia, late of Thomas Hogan Nursing Home, Caroline Chisholm Drive, Kyneton, Victoria 3444, pensioner, and who died on 11 December 2006.

WHYTE, William Crothers, formerly of 2/84 Como Parade West, Mentone, Victoria 3194, but late of Suite 859, The Village Manor, 8 Robinsons Road, Frankston South, Victoria 3199, retired, and who died on 20 March 2007.

Dated 2 April 2007

MARY AMERENA  
Manager  
Executor and Trustee Services

---

## EXEMPTION

Application No. A39/2007

The Victorian Civil and Administrative Tribunal has considered an application pursuant to section 83 of the **Equal Opportunity Act 1995** by Monash University for exemption from sections 13, 14, 37, 42, 100 and 195 of that Act. The application for exemption is to enable the applicant to advertise and offer in its Faculty of Science Women in Research Post-Doctoral Fellowships.

Upon reading the material submitted in support of the application and upon hearing submissions from Ms Amanda Lazar, solicitor, and for the Reasons for Decision given by the Tribunal on 29 March 2007, the Tribunal is satisfied that it is appropriate to grant an exemption from sections 13, 14, 37, 42, 100 and 195 of the Act to enable the applicant to advertise and offer in its Faculty of Science Women in Research Post-Doctoral Fellowships.

The Tribunal hereby grants an exemption to the applicant from the operation of sections 13, 14, 37, 42, 100 and 195 of the **Equal Opportunity Act 1995** to enable the applicant to advertise and offer in its Faculty of Science Women in Research Post-Doctoral Fellowships.

This exemption is to remain in force from the day on which notice of the exemption is published in the Government Gazette until 4 April 2010.

Dated 29 March 2007

C. McKENZIE  
Deputy President

---

## Children's Services Act 1996

### NOTICE OF EXEMPTION

Under section 6 of the **Children's Services Act 1996** ("the Act"), the Minister for Children, hereby declares that the Mallee Minors Child Care Centre Ouyen, Licence ID 10204 ("the service") is exempt from the qualified staff members requirement as set out in regulation 24 of the Children's Services Regulations 1998.

This exemption is granted subject to the conditions that the proprietor must ensure that whenever children are being cared for or educated by the service:

1. the number of staff members as set out in regulation 24 are caring for or educating the children;
2. no more than one nominated staff member is employed in place of qualified staff; and
3. the nominated staff member is undertaking a course to attain a post-secondary early childhood qualification recognised under regulation 25.

This exemption remains in force until 31 July 2007.

Dated 25 March 2007

HON LISA NEVILLE MP  
Minister for Children

#### **Coastal Management Act 1995**

##### **NOTICE OF ENDORSEMENT OF THE BOATING COASTAL ACTION PLAN FOR THE CENTRAL COASTAL REGION**

I, John Thwaites, give notice under section 27 of the **Coastal Management Act 1995**, that on 24 October 2006, on the recommendation of the Victorian Coastal Council, I endorsed, in whole and without amendment, the Boating Coastal Action Plan for the Central Coastal Region prepared by the Central Coastal Board which has been referred to me by the Victorian Coastal Council under section 26 of the Act.

JOHN THWAITES MP  
Minister for Environment

#### **Country Fire Authority Act 1958**

##### **VARIATION OF FIRE DANGER PERIOD**

In pursuance of the powers conferred by Section 4 of the **Country Fire Authority Act 1958**, I, Neil Graeme Bibby, Chief Executive Officer of the Country Fire Authority, after consultation with the Secretary to the Department of Sustainability and Environment, hereby vary the declaration of the Fire Danger Periods previously published in the Government Gazette by declaring that such Fire Danger Periods shall end in respect of the undermentioned Municipal Districts of Municipalities or parts of Municipalities specified.

To terminate from 0100 hours 10 April 2007:  
Campaspe Shire Council, Greater Shepparton City Council, Moira Shire Council, Strathbogie

Shire Council, Greater Bendigo City Council, Loddon Shire Council – remainder, Mount Alexander Shire Council, West Wimmera Shire Council – The Part North of Mosquito Creek in CFA Region 17, Mitchell Shire Council, Murrindindi Shire Council.

NEIL G. BIBBY AFSM  
Chief Executive Officer

#### **Education Act 1958**

##### **NOTICE OF MAKING OF ORDER UNDER SECTION 13 AND ADMINISTRATIVE ARRANGEMENTS ORDER (NO. 192) 2006**

An Order of the Minister for Skills, Education Services and Employment was made on 25 March 2007 under sections 13(4) and 13(11) of the **Education Act 1958** and Administrative Arrangements Order (No. 192) 2006 amending the constituting Order of Landsborough Primary School Council in respect of the membership of the school council.

JACINTA ALLAN, MP  
Minister for Skills, Education  
Services and Employment

#### **Environment Protection Act 1970**

##### **Act No. 8056/1970**

##### **INDUSTRIAL WASTE MANAGEMENT POLICY (PRESCRIBED INDUSTRIAL WASTE)**

##### **Prescribed Industrial Waste Classification**

1. For the purpose of clause 11(1) and in accordance with Schedule 1 of the Industrial Waste Management Policy (Prescribed Industrial Waste) the Authority hereby classifies used oil filters as having currently available<sup>1</sup> opportunities for recycling in the State of Victoria.
2. The classification applies to used oil filters, prescribed as 'waste oils unfit for their original intended use' in Part B of Schedule 1 to the Environment Protection (Prescribed Waste) Regulations 1998.
3. For the purposes of this classification, a used oil filter is a filter that has been used to remove debris from the lubricating oil in an engine. The filter is a paper or synthetic media that is contained in a steel enclosure. Only those used oil filters from industrial

sources are classified as prescribed industrial waste under the Environment Protection (Prescribed Waste) Regulations 1998.

4. This classification will come into effect on 1 July 2007.
1. Currently available: The prescribed industrial waste has potential for reuse, recycling or recovery of energy and such reuse, recycling or recovery of energy is practicable. This means that the facilities required to realise this potential are available in the State of Victoria, or elsewhere in Australia in a location practicably accessible.

**Environment Protection Act 1970**  
**Act No. 8056/1970**

INDUSTRIAL WASTE  
MANAGEMENT POLICY  
(PRESCRIBED INDUSTRIAL WASTE)  
Prescribed Industrial Waste Classification

1. For the purpose of clause 11(1) and in accordance with Schedule 1 of the Industrial Waste Management Policy (Prescribed Industrial Waste) the Authority hereby classifies containers greater than or equal to 200 litres in volume contaminated with prescribed industrial waste as having currently available<sup>1</sup> opportunities for reuse and recycling in the State of Victoria.
2. The classification applies to containers that are rigid steel or plastic, with an original volume greater than or equal to 200 litres, and contaminated with prescribed industrial waste as prescribed in Part B of Schedule 1 to the Environment Protection (Prescribed Waste) Regulations 1998.
3. This classification will come into effect on 1 July 2007.
1. Currently available: The prescribed industrial waste has potential for reuse, recycling or recovery of energy and such reuse, recycling or recovery of energy is practicable. This means that the facilities required to realise this potential are available in the State of Victoria, or elsewhere in Australia in a location practicably accessible.

**Forests Act 1958, No. 6254**

TERMINATION OF  
THE PROHIBITED PERIOD

In pursuance of the powers conferred by section 3 sub-section (2) of the **Forests Act 1958**, I, Stewart Bowe, delegated officer for the

Minister for Environment in the State of Victoria, hereby vary the declaration for the Prohibited Period for all land within the Fire Protected Area (other than State forest, National park and protected public land) within the municipalities nominated for the period specified in the schedule below:

SCHEDULE 1

The Prohibited Period shall terminate at 0100 hours on Tuesday 10 April 2007 in the following municipalities:

Murrindindi Shire, Mitchell Shire, Strathbogie Shire.

The Prohibited Period shall terminate at 0100 hours on Monday 16 April 2007 in the following municipalities:

Baw Baw Shire

STEWART BOWE  
Acting Chief Officer  
Department of Natural Resources  
and Environment  
Delegated Officer  
pursuant to section 11

**Conservation Forests and Land Act 1987**



**Heritage**  
VICTORIA

**Heritage Act 1995**

As Executive Director for the purpose of the **Heritage Act 1995**, I give notice under section 46 that the Victorian Heritage Register is amended by including the Heritage Register Number H276 in the category described as a Heritage Place is now described as:

Eucalyptus Distillery, 1 Brooke Street (Calder Highway), Inglewood, Loddon Shire Council.

EXTENT:

The land shown as L1 on Diagram H0276 held by the Executive Director being the land described in Volume 6479, Folio 784, Parish of Inglewood.

The following buildings marked B1–B2 on Diagram H0276 held by the Executive Director:

B1 Main boiler shelter and associated lean-tos

B2 Pump-house

All of the machinery, structures and plant on the site including the following features marked F1–F11 on Diagram H0276 held by the Executive Director:

F1 Chimney and underground flue to boiler  
 F2, F3 and F4 Brick in-ground vats and associated metal lids  
 F5 Crane  
 F6 Boiler fire chamber formerly used as condenser  
 F7 Boiler and associated brickwork and water and steam piping  
 F8 Gantry and lid for truck mounted steaming vessel, associated pipe-work  
 F9 Condensers, heat exchangers and associated pipe-work, valves, pumps and storage vessels  
 F10 Water tank  
 F11 Redistillation Plant  
 Dated 26 March 2007

RAY TONKIN  
 Executive Director

**Land Acquisition and Compensation Act 1986**

FORM 7 S.21  
 Reg. 16

Notice of Acquisition

Compulsory Acquisition of Interest in Land

The Roads Corporation (VicRoads) declares that by this notice it acquires the following interest in the land described as part of Lot 1 on Plan of Subdivision 116565, Parish of Maribyrnong comprising 343.0 square metres and being land described in Certificate of Title Volume 10313, Folio 134, shown as Parcel 3 on Survey Plan 21291A.

**Interest acquired:** That of Douglas James Borthwick and Sandra Janice Borthwick and all other interests.

Published with the authority of VicRoads.

Dated 5 April 2007

For and on behalf of VicRoads  
 BERNARD TOULET  
 Manager VicRoads Property

**Land Acquisition and Compensation Act 1986**

FORM 7 S.21  
 Reg. 16

Notice of Acquisition

Compulsory Acquisition of Interest in Land

Barwon Region Water Authority declares that by this notice it acquires the following interest in the land described as 155 Barongarook Road, Barongarook 3249 being more particularly

described as Lot 2 on Plan of Subdivision 601894D and being part of Certificates of Title Volume 10171, Folio 740 and Volume 9875, Folio 586:

An easement for water supply purposes over that part of the land shown as E-1 and E-6 comprising an area of 0.137 hectares on the plan for creation of easement dated 22 March 2007, a copy of which is available for perusal at the office of Harwood Andrews Lawyers, 70 Gheringhap Street, Geelong.

Published with the authority of Barwon Region Water Authority

Dated 5 April 2007

For and of behalf of  
 Barwon Region Water Authority

By its lawyers  
 HARWOOD ANDREWS LAWYERS  
 of 70 Gheringhap Street, Geelong 3220

**Land Acquisition and Compensation Act 1986**

FORM 7 S.21  
 Reg. 16

Notice of Acquisition

Compulsory Acquisition of Interest in Land

Barwon Region Water Authority declares that by this notice it acquires the following interest in the land described as 290 Bushbys Road, Barongarook 3249 being more particularly described as Lot 1 on Plan of Subdivision 601894D and being part of Certificates of Title Volume 10171, Folio 740 and Volume 9875, Folio 586:

An easement for water supply purposes over that part of the land shown as E-1 comprising an area of 715 square metres on the plan for creation of easement dated 22 March 2007, a copy of which is available for perusal at the office of Harwood Andrews Lawyers, 70 Gheringhap Street, Geelong.

Published with the authority of Barwon Region Water Authority.

Dated 5 April 2007

For and of behalf of  
 Barwon Region Water Authority

By its lawyers  
 HARWOOD ANDREWS LAWYERS  
 of 70 Gheringhap Street, Geelong 3220

**Monetary Units Act 2004**NOTICE UNDER SECTION 6 FIXING  
THE VALUE OF A FEE UNIT AND A  
PENALTY UNIT

I, John Brumby, Treasurer of the State of Victoria, under section 6 of the **Monetary Units Act 2004**, by notice fix the value of a fee unit and a penalty unit for the financial year commencing 1 July 2007 as follows:

- (a) The value of a fee unit is \$11.02; and
- (b) The value of a penalty unit is \$110.12.

Dated 27 February 2007

JOHN BRUMBY MP  
Treasurer

**Occupational Health and Safety Act 2004**

## VICTORIAN WORKCOVER AUTHORITY

## Notice of Issue of Major Hazard Licence

On 13 October 2006, Westgate Logistics Pty Ltd surrendered their MHF licence under part 8 of the Occupational Health and Safety (Major Hazard Facilities) Regulations 2000.

Westgate Logistics Pty Ltd no longer meets the quantity of materials required to be a Major Hazard Facility.

GREG TWEEDLY  
Chief Executive

**Pipelines Act 1967**

## VARIATION OF PIPELINE PERMIT 78

## Section 12(4)

I, the Minister for Resources, under section 12(4) of the **Pipelines Act 1967**, hereby vary the route of Pipeline Permit 78, owned by GasNet Australia (Operations) Pty Ltd of 180 Greens Road, Dandenong, Victoria 3175 by adding Drawing number T56-11-69 Rev A and T56-11-70 Rev A to the Permit.

Dated 20 March 2007

PETER BATCHELOR  
Minister for Energy and Resources

**Prevention of Cruelty To Animals Act 1986**

## POWER TO FILE CHARGES

I, Peter John Bailey, Executive Director Biosecurity Victoria in the Department of Primary Industries, pursuant to the powers, duties and functions given to me by a delegation under section 38 of **Prevention of Cruelty To**

**Animals Act 1986** and of my respective powers to authorise persons under section 24 of the **Prevention Of Cruelty To Animals Act 1986**, hereby authorise the following persons, who are employees in the Public Service in the Department of Primary Industries to file a charge for an offence under Part 2 of the Act or an offence under the regulations relating to Part 2 of the Act. These authorisations remain in force until revoked or until 30 June 2009.

**Name of person**

Anthony Gerard Britt  
Robert Lloyd Klumpp

Dated 8 March 2007

PETER JOHN BAILEY

Executive Director Biosecurity Victoria

**Subordinate Legislation Act 1994**NOTICE OF PREPARATION OF  
REGULATORY IMPACT STATEMENT

## Country Fire Authority

(Contributions) (Amendment) Regulations 2007

## Metropolitan Fire Brigades

(Contributions) (Amendment) Regulations 2007

Notice is given in accordance with section 11 of the **Subordinate Legislation Act 1994** that a Regulatory Impact Statement (RIS) has been prepared in relation to two sets of regulations: the Country Fire Authority (Contributions) (Amendment) Regulations 2007 and Metropolitan Fire Brigades (Contributions) (Amendment) Regulations 2007 (collectively, "the proposed Regulations").

The reason for the proposed Regulations is to amend the principal Regulations to vary the portion of premiums properly attributable to insurance against fire risk and to amend forms for returns. The objectives of the proposed Regulations are to redistribute fire services funding contributions between insurance companies and simplify forms for premium returns.

The RIS analyses the proposed Regulations and identifies two feasible alternatives. The RIS assesses the costs and benefits of the proposed Regulations and concludes that the benefits of the proposed Regulations outweigh the costs imposed and the proposed Regulations are the best means of achieving the objectives.

Public comments or submissions on the proposed Regulations and the RIS are invited. Copies of both documents can be obtained from: Legal Policy Officer, Strategic Policy & Legislation, Office of the Emergency Services Commissioner, GPO Box 4356, Melbourne, Vic. 3001, tel: (03) 8684 7942, fax: (03) 8684 7956, or from the Department of Justice's internet site: [www.justice.vic.gov.au](http://www.justice.vic.gov.au).

Comments or submissions must be in writing and sent to the above address or to [oesc@justice.vic.gov.au](mailto:oesc@justice.vic.gov.au). All comments or submissions must be received by 5.00pm Friday 4 May 2007. All submissions will be treated as public documents.

Dated 5 April 2007

BOB CAMERON MP  
Minister for Police & Emergency Services

**Transport Act 1983**  
TOW TRUCK DIRECTORATE  
OF VICTORIA

Tow Truck Application

Notice is hereby given that the following application will be considered by the Licensing Authority after 9 May 2007.

Notice of any objection to the granting of an application should be forwarded to reach the Director, Tow Truck Directorate of Victoria, Level 6, 14–20 Blackwood Street, North Melbourne (PO Box 666, North Melbourne 3051) not later than 3 May 2007.

It will not be necessary for interested parties to appear on the date specified, unless advised in writing.

Graham Pickering Towing Pty Ltd. Application for variation of conditions of tow truck licence numbers TOW798 and TOW347 which authorises the licensed vehicles to be managed, controlled and operated from a depot situated at 6–12 Essex Street, Moolap to change the depot address to 26–32 Gordon Avenue, Geelong West.

Note: This Licence is under consideration for transfer to Geelong Accident Repair Centre Pty Ltd.

Dated 5 April 2007

STUART SHEARER  
Director

**Victorian Institute of Teaching Act 2001**

NOTIFICATION CANCELLING  
REGISTRATION OF A TEACHER

Pursuant to section 42 of the **Victorian Institute of Teaching Act 2001**, the Victorian Institute of Teaching may find a teacher has engaged in serious misconduct, has been seriously incompetent and/or is not fit to teach and may make a determination pursuant to sub-section 42(2) including cancelling the registration of a teacher.

On 20 February 2007, Courtenay Peter Charles Baker, born 24 December 1975, was found guilty of serious misconduct and not fit to teach.

On 20 February 2007, Courtenay Peter Charles Baker's registration to teach was cancelled, effective from 20 February 2007.

Dated 28 March 2007

SUSAN HALLIDAY  
Chairperson  
– Disciplinary Proceedings Committee  
Victorian Institute of Teaching



**Water Act 1989**  
GOULBURN–MURRAY RURAL  
WATER AUTHORITY

Extension of Goulburn–Murray  
Irrigation District

Notice is hereby given that Goulburn–Murray Rural Water Authority intends to extend the boundary of its Goulburn–Murray Irrigation District, incorporating Crown Allotment 3, Section C, Parish of Drumanure.

The proposal has been advertised in accordance with the **Water Act 1989**. Submissions will be received for one month after the publication of this notice in the Victoria Government Gazette and should state grounds of objections to the proposal and will be considered at the Board of the Authority's next meeting. Copies of the proposal may be inspected free of charge at the office of Goulburn–Murray Water, 40 Casey Street, Tatura during business hours.

RUSSELL COOPER  
Chief Executive

**Geographic Place Names Act 1998**

## NOTICE OF INTENTION TO REGISTER A GEOGRAPHIC NAME

The Registrar of Geographic Names hereby gives notice of intention to register the undermentioned place name(s) and/or amendments to the boundaries of the undermentioned localities. Any objections to the proposal(s) should be made in writing (stating the reasons therefor) and lodged with the Registrar within 30 days of publication of this notice. If no objections are lodged within this period, any newly proposed names will become the official names and/or any proposed locality boundary amendments will be registered in the Register of Geographic Names.

<b>File No.</b>	<b>Naming Authority</b>	<b>Place Name</b>	<b>Location</b>
LA/12/0076	Towong Shire	Bellbridge, Bethanga, Bullioh, Burrowye, Colac Colac, Eskdale, Georges Creek, Granya, Jarvis Creek, Koetong, Mitta Mitta, Nariel Valley, Talgarno, Tallandoon, Tallangatta East, Tallangatta South, Tallangatta Valley, Thowgla Valley, Towong, Towong Upper.	As on version 4.5 of the plan showing the locality names and boundaries within the municipality. Copies of this plan may be inspected at the municipal offices or at the office of the Registrar of Geographic Names following registration.
GPN 1073	Moorabool Shire	JP Toohey Water Facility	At the Greenes Spring Water Reserve, corner of Donnellans Road and Millbrook–Egerton Road, Millbrook.

Office of the Registrar of Geographic Names

c/- **LAND VICTORIA**

17th Floor

570 Bourke Street

Melbourne 3000

JOHN E. TULLOCH  
Registrar of Geographic Names

**Mineral Resources (Sustainable Development) Act 1990**

DEPARTMENT OF PRIMARY INDUSTRIES

Exemption from Exploration Licence or Mining Licence

I, Richard Aldous, Executive Director Minerals and Petroleum, pursuant to Section 7 of the **Mineral Resources (Sustainable Development Act) 1990** and under delegation by the Minister for Energy & Resources hereby exempt all land situated within the boundaries of the hatched area on the attached map (Schedule A) from being subject to an exploration licence or mining licence.

**Schedule A**

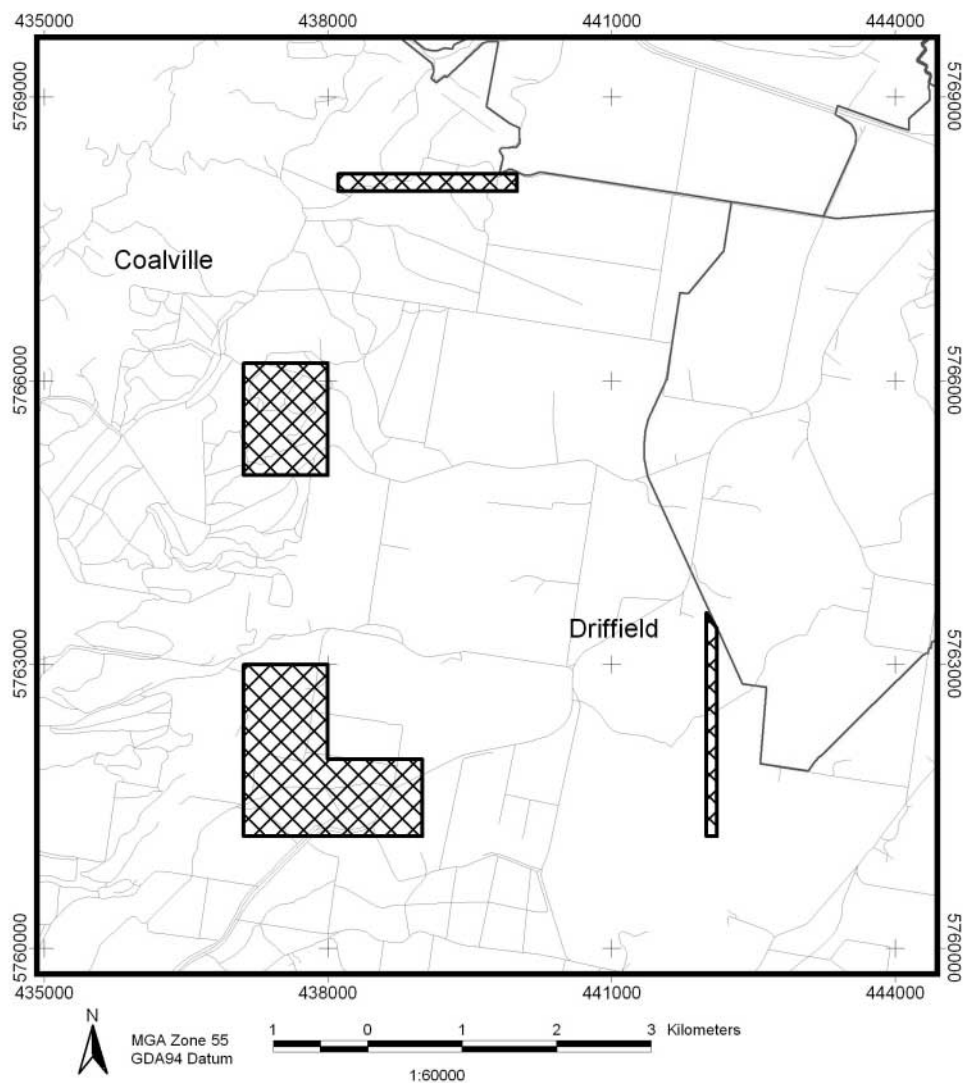

Dated 29 March 2007

RICHARD ALDOUS  
Executive Director  
Minerals and Petroleum



## COMMONWEALTH OF AUSTRALIA

**Petroleum (Submerged Lands) Act 1967**

## NOTICE OF RENEWAL OF PRODUCTION LICENCE FOR PETROLEUM VIC/L13

I, the Delegate of the Designated Authority in respect of the area specified as being adjacent to the State of Victoria, pursuant to the provisions of Section 55 of the **Petroleum (Submerged Lands) Act 1967** hereby grant the renewal of Production Licence for Petroleum VIC/L13 to Esso Australia Resources Pty Ltd and BHP Billiton Petroleum (Bass Strait) Pty Ltd.

**DESCRIPTION OF BLOCKS**

In the adjacent area of the State of Victoria on the Melbourne Map Sheet SJ55 prepared and published for the purposes of the **Petroleum (Submerged Lands) Act 1967**:

BLOCK NO.	BLOCK NO.	BLOCK NO.
2133	2205	2206

Assessed to contain 3 blocks.

Dated 15 March 2007

MADE under the **Petroleum (Submerged Lands) Act 1967** of the Commonwealth of Australia on behalf of the Commonwealth–Victoria Offshore Petroleum Joint Authority

PHILIP ROBERTS  
Director, Minerals and Petroleum Regulation  
Delegate of the Designated Authority

## COMMONWEALTH OF AUSTRALIA

**Petroleum (Submerged Lands) Act 1967**

## NOTICE OF RENEWAL OF PRODUCTION LICENCE FOR PETROLEUM VIC/L14

I, the Delegate of the Designated Authority in respect of the area specified as being adjacent to the State of Victoria, pursuant to the provisions of Section 55 of the **Petroleum (Submerged Lands) Act 1967** hereby grant the renewal of Production Licence for Petroleum VIC/L14 to Esso Australia Resources Pty Ltd and BHP Billiton Petroleum (Bass Strait) Pty Ltd.

**DESCRIPTION OF BLOCKS**

In the adjacent area of the State of Victoria on the Melbourne Map Sheet SJ55 prepared and published for the purposes of the **Petroleum (Submerged Lands) Act 1967**:

BLOCK NO.	BLOCK NO.	BLOCK NO.
2134	2135	2207

Assessed to contain 3 blocks.

Dated 15 March 2007

MADE under the **Petroleum (Submerged Lands) Act 1967** of the Commonwealth of Australia on behalf of the Commonwealth–Victoria Offshore Petroleum Joint Authority

PHILIP ROBERTS  
Director, Minerals and Petroleum Regulation  
Delegate of the Designated Authority

**Public Records Act 1973****DECLARATION OF RECORDS NOT AVAILABLE FOR PUBLIC INSPECTION**

Whereas section 10 of the **Public Records Act 1973** provides, inter alia, that:

“The Minister by notice published in the Government Gazette may declare that any specified records or records of a class transferred or to be transferred from a public office to the Public Record Office shall not be available for public inspection for a period specified in the declaration, being a period of not more than 30 years, after the date of their transfer to the Public Record Office Victoria.”

I, Lynne Janice Kosky, Minister for the Arts, do now by this notice declare that the records listed on the schedule A below shall not be available for public inspection for a period of 15 years from the date of their transfer to the Public Record Office Victoria and that the records listed on the schedule B below shall not be available for public inspection for a period of 30 years from the date of their transfer.

Dated 4 March 2007

LYNNE JANICE KOSKY  
Minister for the Arts

**SCHEDULE A**

<b>VPRS No.</b>	<b>VPRS Title</b>
12809 P8	General Files, Corporate Development Division
12770 P5	General Files, Passenger Services Division, Commercial Department – Business Planning Section
12589 P1	Board Minutes
12577 P1	Minutes (II) MET Management Group

**SCHEDULE B**

<b>VPRS No.</b>	<b>VPRS Title</b>
VPRS 12996 P1	Copies of Inwards Letters
VPRS 12772 P2	Station Development and Commercial Development Project Records
VPRS 12974 P1	Vline Freight Sale Records
VPRS 12864 P2	Project Files, Various Divisions
VPRS 12864 P3	Project Files, Various Divisions
VPRS 13546 P1	General Files, Manager, Human Services Division – Passenger Services
VPRS 13637 P1	Subject Files, Railway Vehicle Maintenance Group
VPRS 12990 P4	Project Records, Melbourne Underground Railway Loop
VPRS 12966 P1	Records Relating to the Privatisation of the Public Transport System (Legal Services Branch)
VPRS 13549 P1	Minutes, Joint Management Meetings
VPRS 12770 P1	General Files, Passenger Services Division, Commercial Department, Business Planning Section
VPRS 12770 P2	General Files, Passenger Services Division, Commercial Department, Business Planning Section
VPRS 12770 P4	General Files, Passenger Services Division, Commercial Department, Business Planning Section
VPRS 12770 P6	General Files, Passenger Services Division, Commercial Department, Business Planning Section
VPRS 12806 P3	General Files, Two Number System, Commercial Development Division

VPRS 12986 P1	General Correspondence Files, Annual Single Number System, Personnel and Organisation Development Division
VPRS 12976 P1	General Files, Multiple Number System, Planning Division
VPRS 12809 P7	General Files, Corporate Development Division
VPRS 12812 P2	General Correspondence Files, Annual Two Number System, Industrial Relations and Personnel Division
VPRS 13547 P1	General Files, Transfer of Interstate Freight Rail Business to National Rail Corporation
VPRS 12997 P1	Copies of Outward Letters
VPRS 8081 P2	Correspondence Files, Multiple Number Sequence
VPRS 12815 P2	General and Project Files, Project Resources Division
VPRS 12815 P3	General and Project Files, Project Resources Division
VPRS 12815 P5	General and Project Files, Project Resources Division
VPRS 12815 P7	General and Project Files, Project Resources Division
VPRS 12802 P3	General Manager's Files
VPRS 12802 P4	General Manager's Files
VPRS 12802 P5	General Manager's Files
VPRS 12802 P6	General Manager's Files
VPRS 12802 P8	General Manager's Files
VPRS 12802 P9	General Manager's Files
VPRS 12813 P1	General Subject Files, Manager, Customer Services, Tram and Bus Division
VPRS 12638 P3	General Correspondence Files, Multiple Number System
VPRS 12817 P2	General Files, Chief Executive Officer
VPRS 13717 P1	General Subject Files, Manager, Jolimont Workshops Depot
VPRS 13417 P1	General File, Financial Report and Manuals, Finance and Administration
VPRS 13417 P2	General File, Financial Report and Manuals, Finance and Administration
VPRS 12809 P11	General Files, Corporate Development Division
VPRS 12770 P3	General Files, Passenger Services Division – Commercial Department – Business Planning Section
VPRS 12962 P1	General Files, Marketing Division
VPRS 12820 P3	General Subject Files, Chairman
VPRS 12961 P2	General and Policy Files, Finance and Administration Branch
VPRS 12975 P1	Subject Files, Director, Planning Division
VPRS 12812 P6	General Correspondence File, Annual Two Number System – Industrial Relations and Personnel Division
VPRS 13417 P4	General Files, Financial Reports and Manuals – Finance and Administration
VPRS 13417 P7	General Files, Financial Reports and Manuals – Finance and Administration
VPRS 12766 P1	Subject Files, Technical Services Division
VPRS 12766 P2	Subject Files, Technical Services Division
VPRS 13935 P1	General Correspondence Files, Annual Single Number System with Alpha Prefix
VPRS 12574 P1	Minutes Corporate Group
VPRS 12820 P1	General Subject Files, Chairman
VPRS 12876 P1	Board Minutes and Papers

**Public Records Act 1973**

## DECLARATION OF RECORDS NOT AVAILABLE FOR PUBLIC INSPECTION

Whereas section 10 AA of the **Public Records Act 1973** provides, inter alia, that:

“The Minister by notice published in the Government Gazette may declare that any specified records or records of a class transferred or to be transferred from a public office to the Public Record Office shall not be available for public inspection for a period specified in the declaration, initially being a period of 50 years from the date of their transfer to the Public Record Office Victoria.”

I, Lynne Janice Kosky, Minister for the Arts, do now by this notice declare that the records listed on the schedule below shall not be available for public inspection for a period of fifty years from the date of their transfer to the Public Record Office Victoria.

Dated 4 March 2007

LYNNE JANICE KOSKY  
Minister for the Arts

**SCHEDULE A**

<b>VPRS No.</b>	<b>VPRS Title</b>	<b>Date Range</b>
07795/P0003	Engineers' Department Files	1952 – 1986
08081/P0004	Correspondence Files, Multiple Number Sequence	1986 – 1988
12637/P0001	General Correspondence Files, Multiple Number System	1983 – 1986
12637/P0002	General Correspondence Files, Multiple Number System	?1983 – 1986
12638/P0001	General Correspondence Files, Multiple Number System	?1983 – ?1991
12638/P0002	General Correspondence Files, Multiple Number System	?1983 – ?1991
12748/P0001	General Correspondence and Works Files, Ways and Works Branch/Engineering and Development Group, Transport Operations Division	1971 – 1983
12748/P0002	General Correspondence and Works Files, Ways and Works Branch/Engineering and Development Group, Transport Operations Division	1984 – 1984
12748/P0003	General Correspondence and Works Files, Ways and Works Branch/Engineering and Development Group, Transport Operations Division	1973 – 1988
12748/P0005	General Correspondence and Works Files, Ways and Works Branch/Engineering and Development Group, Transport Operations Division	1973 – 1985
12748/P0006	General Correspondence and Works Files, Ways and Works Branch/Engineering and Development Group, Transport Operations Division	1978 – 1986
12748/P0007	General Correspondence and Works Files, Ways and Works Branch/Engineering and Development Group, Transport Operations Division	1984 – 1991
12748/P0008	General Correspondence and Works Files, Ways and Works Branch/Engineering and Development Group, Transport Operations Division	1983 – 1990
12748/P0009	General Correspondence and Works Files, Ways and Works Branch/Engineering and Development Group, Transport Operations Division	1977 – 1990
12748/P0010	General Correspondence and Works Files, Ways and Works Branch/Engineering and Development Group, Transport Operations Divisions	1984 – 1984

12771/P0001	Subject Files, Chief General Manager, Transport Operations Division	1982 – 1989
12772/P0001	Station Development and Commercial Development Project Records	1984 – 1991
12772/P0003	Station Development and Commercial Development Project Records	1983 – 1992
12772/P0004	Station Development and Commercial Development Project Records	1983 – 1985
12772/P0005	Station Development and Commercial Development Project Records	1983 – 1988
12772/P0006	Station Development and Commercial Development Project Records	1983 – 1991
12772/P0007	Station Development and Commercial Development Project Records	1983 – 1990
12802/P0001	General Manager's Files	1983 – 1989
12806/P0001	General Files, Two Number System, Commercial Development Division	1987 – 1991
12806/P0002	General Files, Two Number System, Commercial Development Division	1983 – 1990
12808/P0001	Data Pack (Due Diligence Information Pack), Engineering Services Group, Infrastructure	1998 – 1998
12809/P0001	General Files, Corporate Development Division	1983 – 1995
12809/P0002	General Files, Corporate Development Division	1983 – 1997
12809/P0003	General Files, Corporate Development Division	1983 – 1997
12809/P0004	General Files, Corporate Development Division	1983 – 1996
12809/P0005	General Files, Corporate Development Division	1986 – 1995
12809/P0009	General Files, Corporate Development Division	1989 – 1992
12809/P0010	General Files, Corporate Development Division	1983 – 1990
12810/P0001	Capital Works Projects Files, Project Management Group, Alpha Numeric System	1983 – 1992
12810/P0002	Capital Works Projects Files, Project Management Group, Alpha Numeric System	1983 – 1996
12814/P0001	General Subject Files, Track Civil Group, Infrastructure Division	1983 – 1999
12815/P0001	General and Project Files, Projects Resources Division	1984 – 1986
12815/P0006	General and Project Files, Projects Resources Division	1985 – 1990
12857/P0001	General Correspondence Files, Overhead Design, Single Number System	1983 – 1992
12858/P0001	General Correspondence, Overhead Design, Double Number System	?1943 – ?1997
12859/P0001	Subject Files, Overhead Design Group	1955 – 1993
12859/P0004	Subject Files, Overhead Design Group	1951 – 1998
12863/P0001	Bridge Construction Project Records, Project Management Group, Infrastructure Division	1923 – 1925

12863/P0002	Bridge Construction Project Records, Project Management Group, Infrastructure Division	1923 – 1924
12863/P0003	Bridge Construction Project Records, Project Management Group, Infrastructure Division	1923 – 1947
12863/P0004	Bridge Construction Project Records, Project Management Group, Infrastructure Division	1989 – 1995
12863/P0005	Bridge Construction Project Records, Project Management Group, Infrastructure Division	1986 – 1989
12863/P0006	Bridge Construction Project Records, Project Management Group, Infrastructure Division	1986 – 1989
12863/P0007	Bridge Construction Project Records, Project Management Group, Infrastructure Division	1985 – 1992
12863/P0008	Bridge Construction Project Records, Project Management Group, Infrastructure Division	1971 – 1996
12863/P0010	Bridge Construction Project Records, Project Management Group, Infrastructure Division	1986 – 1987
12864/P0001	Project Files, Various Divisions	1992 – 1997
12864/P0009	Project Files, Various Divisions	1990 – 1996
12864/P0011	Project Files, Various Divisions	1974 – 1991
12864/P0012	Project Files, Various Divisions	1974 – 1994
12864/P0014	Project Files, Various Divisions	1982 – 1990
12864/P0016	Project Files, Various Divisions	1989 – 1996
12864/P0017	Project Files, Various Divisions	1965 – 1982
12864/P0018	Project Files, Various Divisions	1978 – 1985
12864/P0020	Project Files, Various Divisions	1984 – 1996
12864/P0022	Project Files, Various Divisions	1958 – 1986
12864/P0023	Project Files, Various Divisions	1981 – 1985
12963/P0001	General Files, Tram and Bus Traffic Operations Support Group, Alpha-Numeric System	1985 – 1993
12962/P0002	General Files, Marketing Division	1987 – 1990
12964/P0001	Subject/Project Manuals, Tram and Bus Operations Support Group	1983 – 1993
12976/P0002	General Files, Multiple Number System, Planning Division	1983 – 1989
12990/P0001	Project Records, Melbourne Underground Railway Loop	1972 – 1980
12990/P0002	Project Records, Melbourne Underground Railway Loop	1971 – 1980
12990/P0005	Project Records, Melbourne Underground Railway Loop	1961 – 1974
12990/P0006	Project Records, Melbourne Underground Railway Loop	1967 – 1982
12990/P0008	Project Records, Melbourne Underground Railway Loop	1967 – 1971
12990/P0010	Project Records, Melbourne Underground Railway Loop	1965 – 1971
12990/P0011	Project Records, Melbourne Underground Railway Loop	1971 – 1993
12990/P0012	Project Records, Melbourne Underground Railway Loop	1964 – 1979
12999/P0001	General Correspondence Files, Multiple Number System	?1971 – ?1993
13000/P0001	Subject Files, Alpha-Numeric System	1971 – 1989

13001/P0001	Contract Administration and General Files, Numerical System	1971 – 1991
13412/P0001	Structural Engineering Design Calculation Files, Single Number with Alpha Prefix, Structural Engineering Section, Civil Engineering Department, Infrastructure Division	1971 – 1995
13412/P0002	Structural Engineering Design Calculation Files, Single Number with Alpha Prefix, Structural Engineering Section, Civil Engineering Department, Infrastructure Division	1971 – 1992
13412/P0003	Structural Engineering Design Calculation Files, Single Number with Alpha Prefix, Structural Engineering Section, Civil Engineering Department, Infrastructure Division	1971 – 1996
13412/P0004	Structural Engineering Design Calculation Files, Single Number with Alpha Prefix, Structural Engineering Section, Civil Engineering Department, Infrastructure Division	1971 – 1997
13414/P0001	Structural Engineering Design Calculation Books, Structural Engineering Design Section	1907 – 1975
13414/P0002	Structural Engineering Design Calculation Books, Structural Engineering Design Section	1927 – 1967
13414/P0003	Structural Engineering Design Calculation Books, Structural Engineering Design Section	1934 – 1971
13415/P0001	Engineering Services Project and General Files, Structural Engineering Department, Infrastructure Division	1970 – 1984
13415/P0002	Engineering Services Project and General Files, Structural Engineering Department, Infrastructure Division	1979 – 1987
13415/P0003	Engineering Services Project and General Files, Structural Engineering Department, Infrastructure Division	1991 – 1992
13415/P0004	Engineering Services Project and General Files, Structural Engineering Department, Infrastructure Division	1992 – 1993
13415/P0005	Engineering Services Project and General Files, Structural Engineering Department, Infrastructure Division	1970 – 1998
13415/P0006	Engineering Services Project and General Files, Structural Engineering Department, Infrastructure Division	1979 – 1988
13415/P0007	Engineering Services Project and General Files, Structural Engineering Department, Infrastructure Division	1970 – 1998
13415/P0008	Engineering Services Project and General Files, Structural Engineering Department, Infrastructure Division	1985 – 1985

13415/P0009	Engineering Services Project and General Files, Structural Engineering Department, Infrastructure Division	1984 – 1998
13415/P0010	Engineering Services Project and General Files, Structural Engineering Department, Infrastructure Division	1970 – 1982
13415/P0011	Engineering Services Project and General Files, Structural Engineering Department, Infrastructure Division	1970 – 1990
13423/P0001	Engineering Project Files	1914 – 1953
13437/P0001	Group Managers' Files, Engineering Services Division	1987 – 1998
13438/P0001	General Managers' Files, Engineering Services, Infrastructure Division, Two Number System	1979 – 1999
13548/P0001	General Files and Capital Works Projects, Freight Services Division	1982 – 1994
13635/P0001	Signalling and Communication Drawings	1916 – 1993
13635/P0002	Signalling and Communication Drawings	1886 – 1992
13635/P0003	Signalling and Communication Drawings	1933 – 1990
13699/P0001	General Files, Vehicle Standards and Engineering Division	?1950 – 1985
13699/P0007	General Files, Vehicle Standards and Engineering Division	1958 – 1991
13699/P0011	General Files, Vehicle Standards and Engineering Division	1957 – 1992
13699/P0013	General Files, Vehicle Standards and Engineering Division	1982 – 1987
13699/P0014	General Files, Vehicle Standards and Engineering Division	1978 – 1982
13699/P0017	General Files, Vehicles Standards and Engineering Division	1978 – 1986
13700/P0003	Subject Files, Vehicle Standards and Engineering Division, Single Number System	1974 – 1991
13700/P0006	Subject Files, Vehicle Standards and Engineering Division, Single Number System	1920 – 1990
13717/P0003	General Subject Files, Manager, Jolimont Workshops Depot	1986 – 1993
13977/P0002	Melbourne Underground Railway Loop Construction and Loop Stations Redevelopment Project Records	1973 – 1992
13977/P0003	Melbourne Underground Railway Loop Construction and Loop Stations Redevelopment Project Records	1971 – 1993
13977/P0004	Melbourne Underground Railway Loop Construction and Loop Stations Redevelopment Project Records	1974 – 1991
13977/P0005	Melbourne Underground Railway Loop Construction and Loop Stations Redevelopment Project Records 1980 to 1993	1980 – 1993



---

13977/P0007	Melbourne Underground Railway Loop Construction and Loop Stations Redevelopment Project Records	1987 – 1990
13977/P0008	Melbourne Underground Railway Loop Construction and Loop Stations Redevelopment Project Records	1982 – 1984
13977/P0009	Melbourne Underground Railway Loop Construction and Loop Stations Redevelopment Project Records	1971 – 1981
13977/P0010	Melbourne Underground Railway Loop Construction and Loop Stations Redevelopment Project Records	1977 – 1983
13977/P0011	Melbourne Underground Railway Loop Construction and Loop Stations Redevelopment Project Records	1979 – 1980
13977/P0012	Melbourne Underground Railway Loop Construction and Loop Stations Redevelopment Project Records	1983 – 1983
13977/P0013	Melbourne Underground Railway Loop Construction and Loop Stations Redevelopment Project Records	1985 – 1985
6347/P0002	General Correspondence Files, Annual Single Number System	1973 – 1982

---

**Planning and Environment Act 1987**

## ALPINE PLANNING SCHEME

## Notice of Approval of Amendment

## Amendment C20

The Minister for Planning has approved Amendment C20 to the Alpine Planning Scheme.

The Amendment comes into operation on the date this notice is published in the Government Gazette.

The Amendment alters the planning scheme maps and the schedule to the Heritage Overlay so that the Alpine Planning Scheme is consistent with that as registered on the Victorian Heritage Register.

A copy of the Amendment can be inspected, free of charge, during office hours, at the Department of Sustainability and Environment, Ground Floor, 8 Nicholson Street, Melbourne; and at the offices of the Alpine Shire Council, corner of Great Alpine Road & Churchill Avenue, Bright.

GENEVIEVE OVERELL  
General Manager

Office of Planning and Urban Design  
Department of Sustainability  
and Environment

**Planning and Environment Act 1987**

## BENALLA PLANNING SCHEME

## Notice of Approval of Amendment

## Amendment C20

The Minister for Planning has approved Amendment C20 to the Benalla Planning Scheme.

The Amendment comes into operation on the date this notice is published in the Government Gazette.

The Amendment alters the planning scheme maps and the schedule to the Heritage Overlay so that the Benalla Planning Scheme is consistent with that as registered on the Victorian Heritage Register.

A copy of the Amendment can be inspected, free of charge, during office hours, at the Department of Sustainability and Environment, Ground Floor, 8 Nicholson Street, Melbourne; and at the offices of the Benalla Rural City Council, Benalla Civic Centre, Fawkner Drive, Benalla.

GENEVIEVE OVERELL

General Manager  
Office of Planning and Urban Design  
Department of Sustainability  
and Environment

**Planning and Environment Act 1987**

## CASEY PLANNING SCHEME

## Notice of Approval of Amendment

## Amendment C77 Part 1

The Minister for Planning has approved Amendment C77 Part 1 to the Casey Planning Scheme.

The Amendment comes into operation on the date this notice is published in the Government Gazette.

The Amendment rezones land known as the Cranbourne North Development Plan area, from a Rural Zone to partly a Residential 1 Zone, partly a Business 1 Zone and partly a Mixed Use Zone; applies a Development Plan Overlay, Environmental Audit Overlay and Public Acquisition Overlay over the land; and makes other consequential changes to the planning scheme.

A copy of the Amendment can be inspected, free of charge, during office hours, at the Department of Sustainability and Environment, Planning Information Centre, Ground Floor, 8 Nicholson Street, East Melbourne; and at the offices of the Casey City Council, Customer Service Centre, Magid Drive, Narre Warren.

GENEVIEVE OVERELL

General Manager  
Office of Planning and Urban Design  
Department of Sustainability  
and Environment

**Planning and Environment Act 1987**

## CASEY PLANNING SCHEME

## Notice of Approval of Amendment

## Amendment C77 Part 2

The Minister for Planning has approved Amendment C77 Part 2 to the Casey Planning Scheme.

The Amendment comes into operation on the date this notice is published in the Government Gazette.

The Amendment affects land generally north of Thompsons Road, east of Narre Warren–Cranbourne Road, generally west of Clyde Road, and south of the proposed Glasscocks Road extension alignment, Cranbourne North and:

- applies a Development Contributions Plans Overlay (DCPO11) over the land;
- inserts a new Schedule 11 to Clause 45.06 (Development Contributions Plan Overlay);
- incorporates the ‘Cranbourne North Development Contributions Plan, City of Casey, January 2007’ into the Schedule to Clause 81.01.

A copy of the Amendment can be inspected, free of charge, during office hours, at the Department of Sustainability and Environment, Planning Information Centre, Ground Floor, 8 Nicholson Street, East Melbourne; and at the offices of the Casey City Council, Magid Drive, Narre Warren.

GENEVIEVE OVERELL  
General Manager  
Office of Planning and Urban Design  
Department of Sustainability  
and Environment

**Planning and Environment Act 1987**

## GREATER GEELONG PLANNING SCHEME

## Notice of Approval of Amendment

## Amendment C120

The Greater Geelong City Council has approved Amendment C120 to the Greater Geelong Planning Scheme.

The Amendment comes into operation on the date this notice is published in the Government Gazette.

The Amendment removes the Environmental Audit Overlay (EAO) from the land at 179 Coppards Road, Moolap and modifies the Schedule to clause 61.03.

The Amendment was approved by the City of Greater Geelong on 24 January 2006 in accordance with authorisation given by the Minister under section 11(1) of the **Planning and Environment Act 1987**. The authorisation has not been withdrawn.

A copy of the Amendment can be inspected, free of charge, during office hours, at the Department of Sustainability and Environment, Planning Information Centre, Ground Floor, 8 Nicholson Street, East Melbourne; and at the offices of the Greater Geelong City Council, 131 Myers Street, Geelong.

GENEVIEVE OVERELL  
General Manager  
Office of Planning and Urban Design  
Department of Sustainability  
and Environment

**Planning and Environment Act 1987**GREATER SHEPPARTON  
PLANNING SCHEME

## Notice of Approval of Amendment

## Amendment C37

The Minister for Planning has approved Amendment C37 to the Greater Shepparton Planning Scheme.

The Amendment comes into operation on the date this notice is published in the Government Gazette.

The Amendment

- amends the Schedule to Clause 52.06–6;
- amends the Schedule to Clause 81.01.

A copy of the Amendment can be inspected, free of charge, during office hours, at the Department of Sustainability and Environment, Planning Information Centre, Ground Floor, 8 Nicholson Street, East Melbourne; North East Regional Office, 89 Sydney Road, Benalla; and at the offices of the Greater Shepparton City Council.

GENEVIEVE OVERELL  
General Manager  
Office of Planning and Urban Design  
Department of Sustainability  
and Environment

**Planning and Environment Act 1987**MORNINGTON PENINSULA  
PLANNING SCHEME

## Notice of Approval of Amendment

## Amendment C92

The Minister for Planning has approved Amendment C92 to the Mornington Peninsula Planning Scheme.

The Amendment comes into operation on the date this notice is published in the Government Gazette.

The Amendment:

- includes land that has been acquired by the Council for public reserves in a Public Park and Recreation Zone (PPRZ) (three sites);
- deletes land from a Public Acquisition Overlay where acquisition is complete and the Overlay is no longer required (three sites); and
- removes privately owned land from a public use zone (six sites).

A copy of the Amendment can be inspected, free of charge, during office hours, at the Department of Sustainability and Environment, Planning Information Centre, Ground Floor, 8 Nicholson Street, East Melbourne; and at the offices of the Mornington Peninsula Shire Municipal Offices, Besgrove Street, Rosebud.

GENEVIEVE OVERELL

General Manager

Office of Planning and Urban Design

Department of Sustainability

and Environment

**Planning and Environment Act 1987**

## MURRINDINDI PLANNING SCHEME

## Notice of Approval of Amendment

## Amendment C13

The Minister for Planning has approved Amendment C13 to the Murrindindi Planning Scheme.

The Amendment comes into operation on the date this notice is published in the Government Gazette.

The Amendment:

- rezones land on the southern side of Station Street, Yea from Business 4 (B4Z) to Mixed Use (MUZ);

- rezones land on the north east corner of Darwin and Lyell Streets, Marysville from Residential 1 (R1Z) to Business 1 Zone (B1Z);
- rezones land on Racecourse Road, Marysville from Industrial 1 (IN1Z) to Residential 1 (R1Z);
- rezones land at CA12A, Section 1, Township Marysville from Residential 1 (R1Z) to Public Conservation and Resource (PCRZ);
- rezones land in Sunds Mill court on the northern side of Sunds Road from Public Use 1 – Service and Utility (PUZ1) to Public Use 6 – Local Government (PUZ6);
- applies the Development Plan Overlay 5, Business, to land on the northern side of High Street, Yea (Planning Scheme Map 7DPO);
- applies the Development Plan Overlay 1, Residential 1, to land on the western side of Racecourse Road, Marysville (Planning Scheme Map 35DPO);
- applies the Development Plan Overlay 5, Business 1, to land in Darwin and Lyell Streets, Marysville (Planning Scheme Map 35DPO);
- applies the Environmental Audit Overlay to land on the western side of Racecourse Road, Marysville (Planning Scheme Map 35EAO); and
- deletes the Development Plan Overlay 1, from land in Darwin and Lyell Streets, Marysville.

A copy of the Amendment can be inspected, free of charge, during office hours, at the Department of Sustainability and Environment, Planning Information Centre, Ground Floor, 8 Nicholson Street, East Melbourne; at the North East Regional Office, 89 Sydney Road, Benalla; and at the offices of the Murrindindi Shire Council, Perkins Street, Alexandra.

GENEVIEVE OVERELL

General Manager

Office of Planning and Urban Design

Department of Sustainability

and Environment

**Planning and Environment Act 1987**  
**WARRNAMBOOL PLANNING SCHEME**  
 Notice of Approval of Amendment  
 Amendment C42

The Minister for Planning has approved Amendment C42 to the Warrnambool Planning Scheme.

The Amendment comes into operation on the date this notice is published in the Government Gazette.

The Amendment rezones 30 to 96 Caramut Road, 29 to 39 Coghlan Road, 1 Fotheringham Street inclusive and part Crown Allotment 34, 72 and 73 Parish of Wangoom and part 191–201 Morriss Road, Warrnambool to Business 3 Zone. This change has the effect of extending the buffer zone between existing residential land and the Warrnambool Saleyards to 300 metres. The Amendment also removes the existing Design and Development Overlay and Development Plan Overlay from the site, which applies to residential land, and applies a new Design and Development Overlay Schedule 12 to all land proposed to be zoned Business 3.

A copy of the Amendment can be inspected, free of charge, during office hours, at the Department of Sustainability and Environment, Planning Information Centre, Ground Floor, 8 Nicholson Street, East Melbourne; and at the offices of the Warrnambool City Council, 25 Liebig Street, Warrnambool 3280.

GENEVIEVE OVERELL  
 General Manager  
 Office of Planning and Urban Design  
 Department of Sustainability  
 and Environment

The Amendment implements the directions from the North Leneva Structure Plan and the Wodonga Retained Environmental Network Strategy (WRENS) by:

- updating the Municipal Strategic Statement;
- rezoning Allotment 2B, Street's Road Leneva to both a Residential 1 and Residential 2 Zone;
- applying a Development Plan Overlay on the land being rezoned;
- applying a Vegetation Protection Overlay as provided for in the WRENS strategy;
- deleting an Environmental Significance Overlay from the land to be rezoned to Residential 1; and
- including the Wodonga Retained Environmental Network Strategy September 2006 as an Incorporated Document in the schedule to clause 81.01.

A copy of the Amendment can be inspected, free of charge, during office hours, at the Department of Sustainability and Environment, Planning Information Centre, Ground Floor, 8 Nicholson Street, East Melbourne; the North East Regional Office, 89 Sydney Road, Benalla; and at the offices of the Wodonga City Council, Hovell Street, Wodonga.

GENEVIEVE OVERELL  
 General Manager  
 Office of Planning and Urban Design  
 Department of Sustainability  
 and Environment

**Planning and Environment Act 1987**  
**WODONGA PLANNING SCHEME**  
 Notice of Approval of Amendment  
 Amendment C37 Part 1

The Minister for Planning has approved Amendment C37 Part 1 to the Wodonga Planning Scheme.

The Amendment comes into operation on the date this notice is published in the Government Gazette.

## ORDERS IN COUNCIL

### **Borrowing and Investments Powers Act 1987**

#### APPROVAL BY THE GOVERNOR IN COUNCIL OF BORROWING POWERS FOR FIRST MILDURA IRRIGATION TRUST

##### Order in Council

The Governor in Council under section 17A of the **Borrowing and Investment Powers Act 1987** (the Act) hereby declares that sections 5, 8, 11, 11AA, 12, 14, 20, 20A and 21 of the Act apply to First Mildura Irrigation Trust, an "Authority" within the meaning of the Act, with effect from and including the date it is published in the Government gazette.

Dated 3 April 2007

Responsible Minister  
JOHN BRUMBY MP  
Treasurer

RUTH LEACH  
Clerk of the Executive Council

### **Borrowing and Investments Powers Act 1987**

#### APPROVAL BY THE GOVERNOR IN COUNCIL OF BORROWING POWERS FOR FIRST MILDURA IRRIGATION TRUST

##### Order in Council

The Governor in Council pursuant to Section 20 of the **Borrowing and Investment Powers Act 1987**, on the recommendation of the Treasurer, hereby approves First Mildura Irrigation Trust, with the approval of the Treasurer, investing its money in the manner described in the Schedule attached to this Order, with effect from and including the date it is published in the Government gazette.

Dated 3 April 2007

Responsible Minister  
JOHN BRUMBY MP  
Treasurer

RUTH LEACH  
Clerk of the Executive Council

#### Schedule

#### FIRST MILDURA IRRIGATION TRUST INVESTMENT POWERS

##### Approved Manner of Investment

- 1) On deposit with –
  - a) the Treasury Corporation of Victoria;
  - b) an Authorised Deposit-taking Institution.

- 2) In the purchase of, or subscription for –
  - a) any certificate of deposit issued by a bank whether negotiable, convertible or otherwise;
  - b) any bill of exchange with a maturity not exceeding 180 days that has been accepted or endorsed by a bank; and
  - c) securities issued by the Treasury Corporation of Victoria with a term to maturity of not more than 365 days from the date of purchase or subscription.

In this Order, unless a contrary intention appears:

"Authorised Deposit-taking Institution" means an Authorised Deposit-taking Institution within the meaning of the **Banking Act 1959** of the Commonwealth;

"Commonwealth" means the Commonwealth of Australia;

Reference to a statute includes references to any amendment or consolidation of, or substitution for the statute.

### **Borrowing and Investments Powers Act 1987**

#### APPROVAL BY THE GOVERNOR IN COUNCIL OF BORROWING POWERS FOR FIRST MILDURA IRRIGATION TRUST

##### Order in Council

The Governor in Council pursuant to Section 21 of the **Borrowing and Investment Powers Act 1987**, on the recommendation of the Treasurer, hereby gives approval for the purposes of that section to First Mildura Irrigation, with effect from and including the date it is published in the Government gazette.

Dated 3 April 2007

Responsible Minister  
JOHN BRUMBY MP  
Treasurer

RUTH LEACH  
Clerk of the Executive Council

**Cemeteries and Crematoria Act 2003**  
 ABOLITION OF THE BRIGHTON  
 CEMETERY TRUST AND TRANSFER  
 OF THE MANAGEMENT OF BRIGHTON  
 GENERAL CEMETERY TO THE  
 CHELTENHAM AND REGIONAL  
 CEMETERIES TRUST

Order in Council

The Governor in Council under section 8 of the **Cemeteries and Crematoria Act 2003**:

- (a) abolishes the Brighton Cemetery Trust; and  
 (b) transfers all the:
- i) assets and liabilities;
  - ii) duties and obligations in relation to staff;
  - iii) duties and obligations under contracts or other arrangements; and
  - iv) records and registers;

of the Brighton Cemetery Trust to the Cheltenham and Regional Cemeteries Trust.

This Order will be effective from the date it is published in the Government Gazette.

Dated 3 April 2007

Responsible Minister

GAVIN JENNINGS MLC

Acting Minister for Health

RUTH LEACH  
 Clerk of the Executive Council

**Crown Land (Reserves) Act 1978**

REVOCATION OF TEMPORARY  
 RESERVATIONS

Order in Council

The Governor in Council under section 10 of the **Crown Land (Reserves) Act 1978** revokes the following temporary reservations:

**BARRAKEE** – The temporary reservation by Order in Council of 29 August 1905 of an area of 3.87 hectares, more or less, of land in the Parish of Barrakee (formerly being part of Crown Allotment 50A) as a site for Public Recreation. – (Rs 4941).

**BEAUFORT** – The temporary reservation by Order in Council of 26 May 1924 of an area of 1.487 hectares, more or less, of land in Section 5, Parish of Beaufort as a site for Supply of Gravel. – (Rs 2938).

**CHARLTON WEST** – The temporary reservation by Order in Council of 3 April 1973 of an area of 93.08 hectares, more or less, of land in the Parish of Charlton West as a site for Public purposes (Public Park, Public Recreation and Trigonometrical Survey Station), revoked as to part by Order in Council of 26 June 1979 so far as the balance remaining containing 93.06 hectares, more or less. – (Rs 9341).

**CHARLTON WEST** – The temporary reservation by Order in Council of 9 February 1892 of an area of 15.378 hectares, more or less, of land in the Parish of Charlton West as a site for a Quarry. – (Rs 3666).

**CHARLTON WEST** – The temporary reservation by Order in Council of 12 June 1928 of an area of 5.327 hectares, more or less, of land in the Parish of Charlton West as a site for a Quarry, in addition to and adjoining the site temporarily reserved therefor by Order in Council of 9 February 1892. – (Rs 3666).

**CHARLTON WEST** – The temporary reservation by Order in Council of 12 June 1928 of an area of 12.141 hectares, more or less, of land in the Parish of Charlton West as a site for a Quarry. – (Rs 3665).

**EDGECOMBE** – The temporary reservation by Order in Council of 30 August 1880 of an area of 3.754 hectares, more or less, of land formerly being Crown Allotment 1 and part Crown Allotment 3 Section A, Parish of Edgcombe as a site for affording access to Water. – (Rs 8232).

**GLENMONA** – The temporary reservation by Order in Council of 2 April 1880 of an area of 4.90 hectares, more or less, of land in the Parish of Glenmona as a site for a Quarry. – (Rs 3719).

**HAWKESDALE** – The temporary reservation by Order in Council of 30 January 1865 of an area of 8094 square metres of land being Crown Allotments 7, 8, 9 and 10, Section 5, Township of Hawkesdale, Parish of Kangertong as a site for a Common School, revoked as to part by Order in Council of 24 January 1995 so far as the balance remaining containing 4487 square metres, more or less. – (C100276).

**MILLOO** – The temporary reservation by Order in Council of 13 September 1880 of an area of 3.2375 hectares of land in the Parish of Milloo (formerly being portion of allotment 20) as a site for Cricket and purposes of Public Recreation. – (Rs 4236).

MILLOO – The temporary reservation by Order in Council of 29 May 1894 of an area of 2.72 hectares of land in the Parish of Milloo (formerly being portion of allotment 20) as a site for Cricket and purposes of Public Recreation, in addition to and adjoining the site temporarily reserved therefor by Order in Council of 13 September 1880. – (Rs 4236).

MILLOO – The temporary reservation by Order in Council of 29 May 1894 of an area of 5.57 hectares of land in the Parish of Milloo (formerly being part of allotment 20) as a site for Water Supply purposes, so far only as the portions being Crown Allotments 2002 and 2003, Parish of Milloo as shown hatched on Plan No. LEGL./06–440 lodged in the Central Plan Office of the Department of Sustainability and Environment. – (Rs 4235).

OAKLEIGH – The temporary reservation by Order in Council of 21 October 1940 of an area of 17.81 hectares, more or less, of land in the Township of Oakleigh, Parish of Mulgrave as a site for Public Park and Recreation, revoked as to part by various Orders, so far only as the portion containing 406 square metres being Crown Allotment 2001, Township of Oakleigh, Parish of Mulgrave as indicated by hatching on plan published in the Government Gazette of 15 February 2007 page 281. – (Rs 1121).

RAVENSWOOD – The temporary reservation by Order in Council of 20 November 1883 of an area of 4.047 hectares, more or less, of land in Section 29, Parish of Ravenswood as a site for a Quarry. – (Rs 2813).

ST. ARNAUD – The temporary reservation by Order in Council of 22 October 1918 of an area of 510 square metres, more or less, of land in Section E1, Township of St. Arnaud, [formerly borough of St. Arnaud], Parish of St. Arnaud as a site for a Fire Brigade Station. – (Rs 01856).

YARRABERB – The temporary reservation by Order in Council of 31 August 1874 of an area of 47.97 hectares, more or less, of land in Section 32, Parish of Yarraberb (formerly being part Crown Allotment 2) as a site for Watering purposes, revoked as to part by Order in Council of 25 August 1879 so far as the balance remaining containing 24.23 hectares, more or less. – (Rs 11582).

This Order is effective from the date on which it is published in the Government Gazette.

Dated 3 April 2007

Responsible Minister  
JUSTIN MADDEN  
Minister for Planning

RUTH LEACH  
Clerk of the Executive Council

### Crown Land (Reserves) Act 1978

#### TEMPORARY RESERVATION OF CROWN LANDS

##### Order in Council

The Governor in Council under section 4(1) of the **Crown Land (Reserves) Act 1978** temporarily reserves the following Crown lands which in his opinion are required for the purposes mentioned:–

#### MUNICIPAL DISTRICT OF THE LODDON SHIRE COUNCIL

BARRAKEE – Conservation of an area of historic and cultural interest, total area 15 hectares, more or less, being Crown Allotments 50P, 2005 and 2006, Parish of Barrakee as shown hatched on Plan No. LEGL./06–474 lodged in the Central Plan Office of the Department of Sustainability and Environment. – (06L6–10927).

#### MUNICIPAL DISTRICT OF THE PYRENEES SHIRE COUNCIL

BEAUFORT – Public Recreation, total area 2.9 hectares, more or less, being Crown Allotments 32F and 32G, Section 5, Parish of Beaufort as indicated by hatching on plan hereunder. (GP2314) – (0505567).

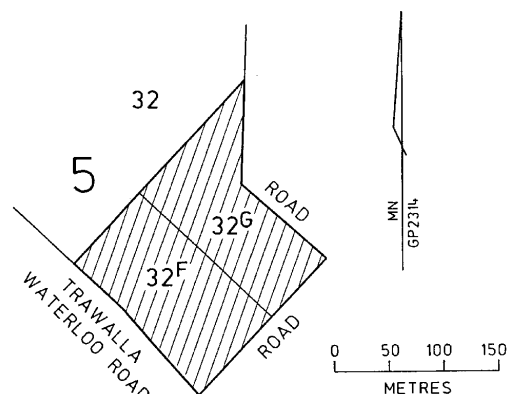

Total Area of Hatched  
Portions is 2.9ha<sup>2</sup>



**MUNICIPAL DISTRICT OF THE  
INDIGO SHIRE COUNCIL**

**CHILTERN** – Conservation of an area of natural interest, total area 7.77 hectares, more or less, being Crown Allotments 11A of Section 10A and Crown Allotment 2006, Township of Chiltern, Parish of Chiltern as shown hatched on Plan No. LEGL./06-469 lodged in the Central Plan Office of the Department of Sustainability and Environment. – (11P203385).

**MUNICIPAL DISTRICT OF THE MACEDON  
RANGES SHIRE COUNCIL**

**EDGECOMBE** – Conservation of an area of natural interest, total area 4.7 hectares, more or less, being Crown Allotment 2001 and Crown Allotment 2, Section A, Parish of Edgcombe as indicated by hatching on plan hereunder. (GP2165A) – (06015930).

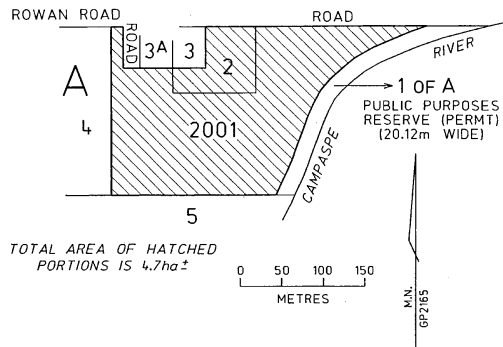

**MUNICIPAL DISTRICT OF THE PYRENEES  
SHIRE COUNCIL**

**GLENMONA** – Conservation of an area of natural interest, 4.897 hectares, being Crown Allotment 35B, Section M, Parish of Glenmona as indicated by hatching on plan hereunder. (GP1485) – (0615706).

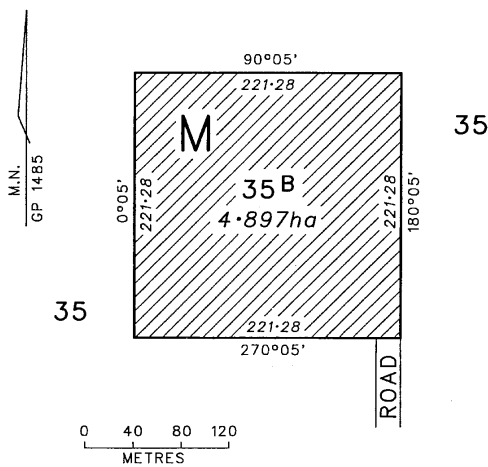

**MUNICIPAL DISTRICT OF THE  
NORTHERN GRAMPIANS SHIRE  
COUNCIL**

**ILLAWARRA** – Conservation of an area of natural interest, total area 1.5 hectares, more or less, being Crown Allotments 2024 and 2025, Parish of Illawarra as shown hatched on Plan No. LEGL./06-485 lodged in the Central Plan Office of the Department of Sustainability and Environment. – (02P022232).

**MUNICIPAL DISTRICT OF THE MACEDON  
RANGES SHIRE COUNCIL**

**LANGLEY** – Conservation of an area of natural interest, 75 hectares, more or less, being Crown Allotment 2001, Parish of Langley as shown hatched on Plan No. LEGL./07-001 lodged in the Central Plan Office of the Department of Sustainability and Environment. – (06P142256).

**MUNICIPAL DISTRICT OF THE  
CAMPASPE SHIRE COUNCIL**

**MILLOO** – Conservation of an area of natural interest, total area 10.8 hectares, more or less, being Crown Allotments 20B, 20C, 2001, 2002 and 2003, Parish of Milloo as shown hatched on Plan No. LEGL./06-440 lodged in the Central Plan Office of the Department of Sustainability and Environment. – (0613774).

**MUNICIPAL DISTRICT OF THE  
GREATER BENDIGO CITY COUNCIL**

**NERRING** – Conservation of an area of natural interest, 4019 square metres, being Crown Allotment 2004, Parish of Nerring as indicated by hatching on plan hereunder. (GP2372) – (2015293).

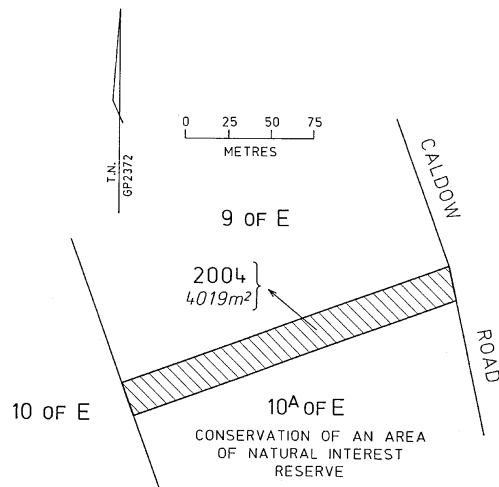

MUNICIPAL DISTRICT OF THE  
CITY OF PORT PHILLIP

ST. KILDA – Public purposes, 2.5 hectares, more or less, being Crown Allotment 2006, At St. Kilda, Parish of Melbourne South as indicated by hatching on plan hereunder. (GP2373) – (12Rs 50).

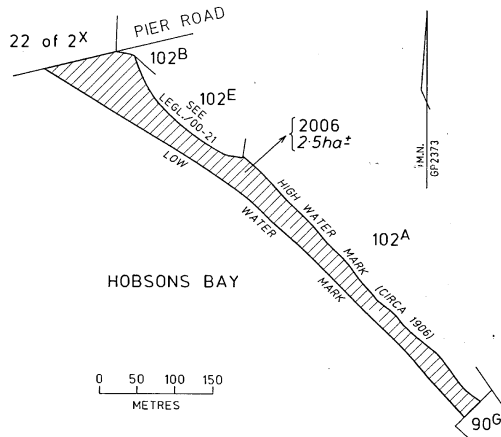

MUNICIPAL DISTRICT OF THE  
WODONGA CITY COUNCIL

WODONGA – Public purposes (Police and Court purposes), 7550 square metres, being Crown Allotment 2017, Township of Wodonga, Parish of Wodonga as shown on Original Plan No. 121979 lodged in the Central Plan Office of the Department of Sustainability and Environment. – (11P373614).

MUNICIPAL DISTRICT OF THE  
LODDON SHIRE COUNCIL

YARRABERB – Conservation of an area of natural interest, area 21.6 hectares, more or less, being Crown Allotment 2D, Section 32, Parish of Yarraberb as shown hatched on Plan No. LEGL./06-446 lodged in the Central Plan Office of the Department of Sustainability and Environment. – (0609535).

This Order is effective from the date on which it is published in the Government Gazette.

Dated 3 April 2007

Responsible Minister  
JUSTIN MADDEN  
Minister for Planning

RUTH LEACH  
Clerk of the Executive Council

**Crown Land (Reserves) Act 1978**

NOTICE OF INTENTION TO REVOKE  
TEMPORARY RESERVATIONS

Order in Council

The Governor in Council under section 10 of the **Crown Land (Reserves) Act 1978** gives notice of intention to revoke the following temporary reservations:

**BENDIGO** – The temporary reservation by Order in Council of 27 May 1980 of an area of 55.80 hectares of land being Crown Allotment 8, Section F10, Crown Allotment 2, Section F11, and Crown Allotment 3, Section F12, At Bendigo, Parish of Sandhurst as a site for the Preservation of Species of Native Plants, revoked as to part by Order in Council of 27 March 1990 so far as the balance remaining containing 55.77 hectares, more or less. – (Rs 11086).

**BENDIGO** – The temporary reservation by Order in Council of 16 July 1985 of an area of 8.761 hectares, of land being Crown Allotment 8A, Section F10, At Bendigo, Parish of Sandhurst as a site for the Preservation of Species of Native Plants. – (Rs 11086).

**BENDIGO** – The temporary reservation by Order in Council of 21 August 2001 of an area of 22.50 hectares, of land being Crown Allotments 28G and 28F, Section K1, At Bendigo, Parish of Sandhurst as a site for the Preservation of species of native plants. – (0607519).

**SOUTH MELBOURNE** – The temporary reservation by Order in Council of 16 January 1962 of an area of 7335 square metres, more or less, of land in the City of South Melbourne, Parish of Melbourne South as a site for State School purposes. – (Rs 5398).

**WATTA WELLA** – The temporary reservation by Order in Council of 26 October 1885 of an area of 4.047 hectares, more or less, of land formerly being part of Crown Allotment 7B, Parish of Watta Wella as a site for Supply of Gravel. – (Rs 13371).

This Order is effective from the date on which it is published in the Government Gazette.

Dated 3 April 2007

Responsible Minister  
JUSTIN MADDEN  
Minister for Planning

RUTH LEACH  
Clerk of the Executive Council

**Crown Land (Reserves) Act 1978**  
**DISSOLUTION OF INCORPORATED**  
**COMMITTEE OF MANAGEMENT**

Order in Council

The Governor in Council under Section 14A(7) of the **Crown Land (Reserves) Act 1978** dissolves the "Ross Creek Recreation Reserve Committee of Management Incorporated" constituted by Order in Council of 7 November, 2001 vide Government Gazette of 8 November, 2001 – page 2816. – (Rs 0457 [0512713]).

This Order is effective from the date on which it is published in the Government Gazette.

Dated 3 April 2007

Responsible Minister  
**JUSTIN MADDEN**  
 Minister for Planning

**RUTH LEACH**  
 Clerk of the Executive Council

**Land Act 1958**  
**CLOSURE OF UNUSED ROADS**  
 Order in Council

The Governor in Council under section 349 of the **Land Act 1958** and with the concurrence in writing of the municipalities in which the roads are situated and the owners of land adjoining those roads closes the following unused roads:

**MUNICIPAL DISTRICT OF THE**  
**EAST GIPPSLAND SHIRE COUNCIL**

**BENAMBRA** – The road in the Township of Benambra, Parish of Hinno–Munjie being Crown Allotment 2001 as indicated by hatching on plan hereunder. (GP2311) – (16L9–5683).

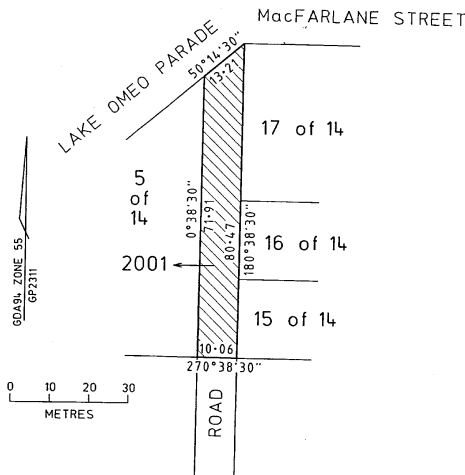

**MUNICIPAL DISTRICT OF THE**  
**INDIGO SHIRE COUNCIL**

**CHILTERN** – The road in the Township of Chiltern, Parish of Chiltern being Crown Allotment 2005 as indicated by hatching on plan hereunder. (GP2313) – (11P203385).

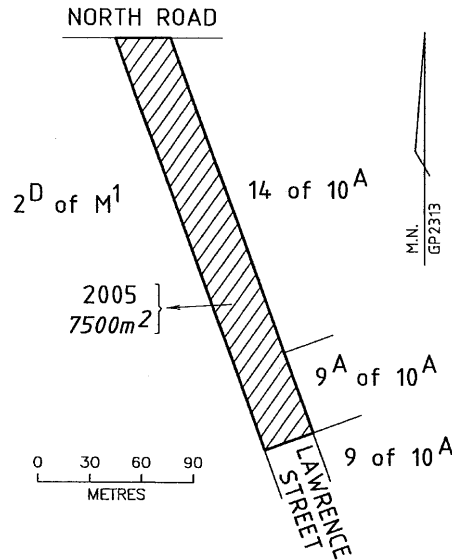

**MUNICIPAL DISTRICT OF THE**  
**WELLINGTON SHIRE COUNCIL**

**GLENCOE** – The road in the Parish of Glencoe being Crown Allotment 2003 as indicated by hatching on plan hereunder. (GP2081) – (15L10–6761).

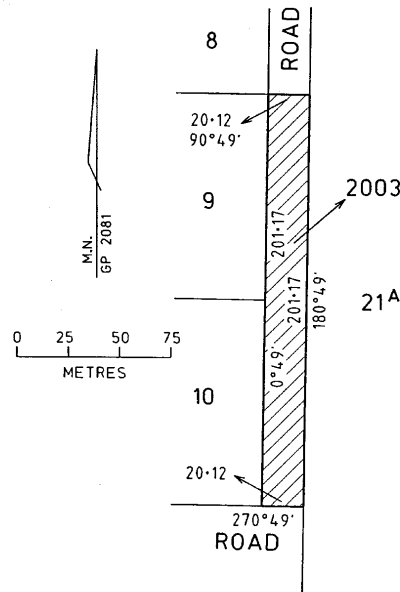

MUNICIPAL DISTRICT OF THE  
YARRA RANGES SHIRE COUNCIL

MONDA – The road in the Parish of Monda being Crown Allotment 222 as indicated by hatching on plan hereunder. (GP2371) – (12L12–1110).

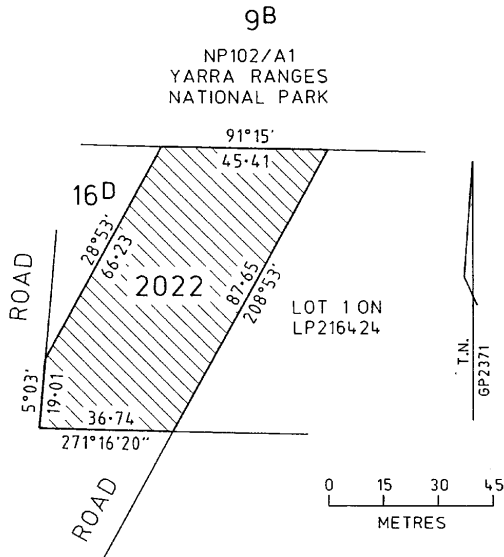

This Order is effective from the date on which it is published in the Government Gazette.

Dated 3 April 2007  
Responsible Minister  
JUSTIN MADDEN  
Minister for Planning

RUTH LEACH  
Clerk of the Executive Council

STATEMENT OF TRUSTS  
DESCRIPTION OF LAND

Site for Church of England Place of Public Worship permanently reserved by order in council 18 November 1872.

4063 square metres, Township of Dartmoor, Parish of Dartmoor, County of Follett, being Crown allotment 2 section 9.

Commencing at the north-western angle of allotment 3 section 9 Township of Dartmoor, bounded thence by the said allotment bearing 180°00' 100.58 metres; thence by a road bearing 270°00' 29.37 metres and 256°00' 11.27 metres; thence by a line bearing 0°00' 103.20 metres; thence by Lang Street bearing 90°00' 40.23 metres to the point of commencement.

NAME OF TRUSTEES

The Ballarat Diocesan Trustees.

POWERS OF DISPOSITION

Powers to sell, mortgage or lease.

PURPOSES TOWARDS WHICH PROCEEDS OF DISPOSITION ARE TO BE APPLIED

Church purposes.

This Order is effective from the date on which it is published in the Government Gazette.

Dated 3 April 2007  
Responsible Minister  
JUSTIN MADDEN  
Minister for Planning

RUTH LEACH  
Clerk of the Executive Council

VICTORIA

State Aid to Religion Abolition Act 1871

ACT NO. 391/1871 – SECOND SCHEDULE

A statement of trusts having been submitted by the head or authorised representative of the Anglican Church in Australia in the Diocese of Ballarat in Victoria under the provisions of the “Act to provide for the abolition of State Aid to Religion” for allowance by the Governor in Council, the same was allowed by him on the Third day of April 2007 and the following is the form in which such statement of trusts has been allowed.

**Fisheries Act 1995**FISHERIES (TAKING, KEEPING OR SELLING OF CERTAIN  
PROTECTED AQUATIC BIOTA) ORDER NO. 1/2007

## Order in Council

The Governor in Council makes the following Order:

**Objective**

1. The objective of this Order is to authorise, subject to conditions, the taking, keeping and selling of certain protected aquatic biota.

**Authorising provision**

2. This Order is made under section 73 of the **Fisheries Act 1995**.

**Commencement**

3. This Order comes into operation on the day on which it is published in the Victorian Government Gazette.

**Definitions**

4. In this Order, “syngnathids” means the taxa of Family *Syngnathidae* (all species including seahorses, seadragons and pipefish).

**Authorisation to sell syngnathids**

5. A person may sell syngnathids provided that the person –
  - (a) before selling the syngnathids, creates a document concerning the proposed sale which contains the following information –
    - (i) the name and address of seller;
    - (ii) the date of the sale;
    - (iii) the species of syngnathid;
    - (iv) the quantity of individual species of syngnathids sold;
    - (v) a unique identifying number generated from a sequential system of numbering the record of the sale; and
  - (b) in the case of a sale of syngnathids by consignment, ensures that a copy of the document accompanies the consignment; and
  - (c) in the case of any other sale, ensures that a copy of the document is given to the purchaser at or before the sale; and
  - (d) keeps a copy of the document; and
  - (e) if asked to do so by an authorised officer or a member of the police force, produce for inspection any document the person has created under this clause that is in his or her possession.

**Authorisation to take or keep syngnathids**

6. A person may take or keep syngnathids provided that the person –
  - (a) does not take the syngnathids from Victorian waters; and
  - (b) obtains, on taking the syngnathids, a copy of a document from the seller which contains the following information –
    - (i) the name and address of seller;
    - (ii) the date of the sale;
    - (iii) the species of syngnathid;
    - (iv) the quantity of individual species of syngnathids sold;
    - (v) a unique identifying number generated from a sequential system of numbering the record of the sale; and

- (c) keeps a copy of the document; and
- (d) if asked to do so by an authorised officer or a member of the police force, produce for inspection any document the person has created under this clause that is in his or her possession.

Notes:

1. The **Fisheries Act 1995** defines “take” to mean gain possession or control by any means. It therefore includes buying protected aquatic biota.
2. A person may take syngnathids from Victorian waters if authorised to do so by a permit issued under section 72 of the **Fisheries Act 1995**.
3. This Order does not authorise a person to display for reward or release into Victorian waters syngnathids. Section 71 of the **Fisheries Act 1995** makes it an offence to display for reward or release into Victorian waters protected aquatic biota without a permit or unless authorised by an Order in Council under section 73 of the **Fisheries Act 1995**.
4. Section 120B of the **Fisheries Act 1995** requires that a document of the sort referred to under clause 5 or 6 of this Order must be kept for at least 3 years after its creation.

Dated 3 April 2007

Responsible Minister  
JOE HELPER, MP  
Minister for Agriculture

RUTH LEACH  
Clerk of the Executive Council

---

This page was left blank intentionally

This page was left blank intentionally



This page was left blank intentionally

**SUBORDINATE LEGISLATION ACT 1994  
NOTICE THAT STATUTORY RULES ARE  
OBTAINABLE**

Notice is hereby given under Section 17(3) of the **Subordinate Legislation Act 1994** that the following Statutory Rules were first obtainable from Information Victoria, 356 Collins Street, Melbourne on the date specified:

- |     |  |     |   |
|-----|--|-----|---|
| 15. | <p><i>Statutory Rule:</i> Pipelines Regulations 2007</p> <p><i>Authorising Act:</i> Pipelines Act 2005</p> <p><i>Date first obtainable:</i> 5 April 2007</p> <p><i>Code C</i></p>  | 19. | <p><i>Statutory Rule:</i> Building and Construction Industry Security of Payment (Amendment) Regulations 2007</p> <p><i>Authorising Act:</i> Building and Construction Industry Security of Payment Act 2002</p> <p><i>Date first obtainable:</i> 5 April 2007</p> <p><i>Code A</i></p> |
| 16. | <p><i>Statutory Rule:</i> Electricity Safety (Equipment Efficiency) (Amendment) Regulations 2007</p> <p><i>Authorising Act:</i> Electricity Safety Act 1998</p> <p><i>Date first obtainable:</i> 5 April 2007</p> <p><i>Code A</i></p>       | 20. | <p><i>Statutory Rule:</i> Transport (Infringements) (Penalties) Regulations 2007</p> <p><i>Authorising Act:</i> Transport Act 1983</p> <p><i>Date first obtainable:</i> 5 April 2007</p> <p><i>Code A</i></p>   |
| 17. | <p><i>Statutory Rule:</i> Tobacco (Victorian Health Promotion Foundation) (Membership Amendment) Regulations 2007</p> <p><i>Authorising Act:</i> Tobacco Act 1987</p> <p><i>Date first obtainable:</i> 5 April 2007</p> <p><i>Code A</i></p> |     |   |
| 18. | <p><i>Statutory Rule:</i> Sex Offenders Registration (Amendment) Regulations 2007</p> <p><i>Authorising Act:</i> Sex Offenders Registration Act 2004</p> <p><i>Date first obtainable:</i> 5 April 2007</p> <p><i>Code A</i></p>              |     |   |

**PRICING FOR SPECIAL GAZETTE,  
PERIODICAL GAZETTE AND  
VICTORIAN LEGISLATION**

As from 1 January 2007 the pricing structure for the Victoria Government Gazette and Victorian Government Legislation will be as follows.

Retail price varies according to the number of pages in each Victoria Government Special Gazette, Victoria Government Periodical Gazette and Victorian legislation. The table below sets out the prices that apply.

<i>Price Code</i>	<i>No. of Pages (Including cover and blank pages)</i>	<i>Price*</i>
A	1–16	\$3.80
B	17–32	\$5.70
C	33–48	\$7.80
D	49–96	\$12.20
E	97–144	\$15.75
F	145–192	\$18.65
G	193–240	\$21.50
H	241–288	\$22.90
I	289–352	\$25.75
J	353–416	\$30.10
K	417–480	\$34.35
L	481–544	\$40.10
M	545–608	\$45.80
N	609–672	\$50.55
O	673–736	\$57.25
P	737–800	\$63.00

*\*All Prices Include GST*

**craftsmanpress**

The *Victoria Government Gazette* is published by The Craftsman Press Pty Ltd with the authority of the Government Printer for the State of Victoria

© State of Victoria 2007

This publication is copyright. No part may be reproduced by any process except in accordance with the provisions of the Copyright Act.

Address all enquiries to the Government Printer for the State of Victoria  
Level 2 1 Macarthur Street  
Melbourne 3002  
Victoria Australia

**How To Order**

**Mail Order**      **Victoria Government Gazette**  
Level 1 520 Bourke Street  
Melbourne 3000  
PO Box 1957 Melbourne 3001  
DX 106 Melbourne



**Telephone**      (03) 9642 5808



**Fax**      (03) 9600 0478

**email**      [gazette@craftpress.com.au](mailto:gazette@craftpress.com.au)



**Retail & Mail Sales**      **Victoria Government Gazette**  
Level 1 520 Bourke Street  
Melbourne 3000  
PO Box 1957 Melbourne 3001



**Telephone**      (03) 9642 5808



**Fax**      (03) 9600 0478



**Retail Sales**      **Information Victoria**  
356 Collins Street  
Melbourne 3000



**Telephone**      1300 366 356



**Fax**      (03) 9603 9920

**Recommended Retail Price \$1.95 (includes GST)**

ISSN 0819-5471



9 770819 551772