



# **Victoria Government Gazette**

By Authority of Victorian Government Printer

**No. G 2 Thursday 10 January 2008**

[www.gazette.vic.gov.au](http://www.gazette.vic.gov.au)

**GENERAL**

---

**TABLE OF PROVISIONS**

---

Estates of Deceased Persons	
Aitken Walker & Strachan	60
Andrew Gray & Associates	60
Mills Oakley Lawyers	60
Pietrzak	60
Russell Kennedy	60
Government and Outer Budget Sector	
Agencies Notices	61

---

**Advertisers Please Note**

As from 10 January 2008

The last Special Gazette was No. 4 dated 8 January 2008.

The last Periodical Gazette was No. 2 dated 26 October 2007.

---

**How To Submit Copy**

- See our webpage [www.craftpress.com.au](http://www.craftpress.com.au)
  - or contact our office on 9642 5808  
between 8.30 am and 5.30 pm Monday to Friday
- 

**Copies of recent Special Gazettes can now be viewed at the following display cabinet:**

- 1 Treasury Place, Melbourne (behind the Old Treasury Building)
-

**PUBLICATION OF THE VICTORIA GOVERNMENT GAZETTE (GENERAL)  
AUSTRALIA DAY WEEK 2008 (Thursday 31 January 2008)**

**Please Note:**

The Victoria Government Gazette for Australia Day week (G5/08) will be published on **Thursday 31 January 2008**.

**Copy deadlines:**

Private Advertisements **9.30 am on Friday 25 January 2008**

Government and Outer  
Budget Sector Agencies Notices **9.30 am on Tuesday 29 January 2008**

Where urgent gazettal is required after hours, arrangements should be made with the Government Gazette Officer on 0419 327 321.

JENNY NOAKES  
Government Gazette Officer

---

**VICTORIA GOVERNMENT GAZETTE**

**Subscribers and Advertisers**

**Our contact details are as follows:**

Victoria Government Gazette Office  
Level 1, 520 Bourke Street  
Melbourne, Victoria 3000

PO Box 1957  
Melbourne, Victoria 3001

DX 106 Melbourne

Telephone: (03) 9642 5808  
Fax: (03) 9600 0478  
Mobile (after hours): 0419 327 321

Email: [gazette@craftpress.com.au](mailto:gazette@craftpress.com.au)  
Website: [www.gazette.vic.gov.au](http://www.gazette.vic.gov.au)

JENNY NOAKES  
Government Gazette Officer

---

### PRIVATE ADVERTISEMENTS

Re: PHUOC TA, late of 26/76 Canning Street, North Melbourne, Victoria, pensioner, deceased.

Creditors, next-of-kin and others having claims in respect of the estate of the deceased, who died on 27 May 2006, are required by the trustee, Nancy Tam of 5/27 Andrews Street, Burwood, Victoria, hostel manager, to send particulars to her, care of the undersigned solicitors, by 12 March 2008, after which date the trustee may convey or distribute the assets, having regard only to the claims of which the trustee then has notice.

AITKEN WALKER & STRACHAN, solicitors,  
Level 1, 114 William Street, Melbourne 3000.

Re: MARTINUS ARNOLDUS VAN THIEL, late of Melville Grange, 80 Melville Park Drive, Berwick, Victoria.

Creditors, next-of-kin and others having claims in respect of the estate of the deceased, who died on 11 May 2007, are required by the trustee, Leanne Julie Johnson, care of the undermentioned solicitors, to send particulars to her by 11 March 2008, after which date the trustee may convey or distribute the assets, having regard only to the claims of which she then has notice.

ANDREW GRAY & ASSOCIATES, solicitors,  
Old Post Office, 102 High Street, Berwick,  
Victoria 3806.

Estate of SHEILA KATHLEEN FORRISTAL, late of Ardmillan Place, 88 Holmes Road, Moonee Ponds, Victoria, retired, deceased.

Creditors, next-of-kin and others having claims in respect of the estate of the deceased, who died on 28 November 2007, are required by the executor, ANZ Trustees Limited, ACN 006 132 332, of 100 Queen Street, Melbourne, to send particulars to it by 11 March 2008, after which date it may convey or distribute the assets, having regard only to the claims of which it then has notice.

MILLS OAKLEY LAWYERS,  
121 William Street, Melbourne 3000.

Creditors, next-of-kin and others having claims in respect of the estate of WACLAW NADOLSKI, late of 51 Vernon Street, South Kingsville, in the State of Victoria, pensioner, deceased, who died on 27 November 2007, are required to send particulars of such claims to the executors, care of the undermentioned solicitors, by 13 March 2008, after which date the executors will convey or distribute the assets, having regard only to the claims of which the executors then have notice.

PIETRZAK SOLICITORS,  
222 Latrobe Street, Melbourne 3000.

Re: ENID MAY GARDINER, deceased.

Creditors, next-of-kin and others having claims in respect of the estate of the deceased, late of 'Collins Point', 3652 Point Nepean Road, Portsea, Victoria, home duties, who died on 6 October 2007, are required by the trustees, Equity Trustees Limited, ABN 46 004 031 298, and Robert Bruce Gardiner, both care of Level 2, 575 Bourke Street, Melbourne, Victoria 3000, to send particulars to the trustees by 25 March 2008, after which date the trustees may convey or distribute the assets, having regard only to the claims of which the trustees then have notice.

RUSSELL KENNEDY, solicitors,  
Level 12, 469 La Trobe Street, Melbourne  
3000.

Re: MARGERY ISABEL PIERCE, deceased.

Creditors, next-of-kin and others having claims in respect of the estate of the deceased, late of 2 Macquarie Road, Toorak, Victoria, home duties, who died on 27 July 2007, are required by the trustees, Antonia Carole Armstrong and Martin John O'Dell Armstrong, to send particulars to the trustees, care of the solicitors named below, by 13 March 2008, after which date the trustees may convey or distribute the assets, having regard only to the claims of which the trustees have notice.

RUSSELL KENNEDY, solicitors,  
Level 12, 469 La Trobe Street, Melbourne  
3000.

**GOVERNMENT AND OUTER BUDGET  
SECTOR AGENCIES NOTICES**



Road Discontinuance

Pursuant to section 206 and schedule 10, clause 3 of the **Local Government Act 1989**, the Latrobe City Council at its Ordinary meeting held on 17 December 2007, formed the opinion that the unnamed road reserve created on LP 53583 and abutting 30, 32, 34 and 38 Queens Parade, Traralgon, shown on the plan below is not reasonably required as a road for public use, and resolved to discontinue the road and transfer the land by private treaty to the adjoining property owners.

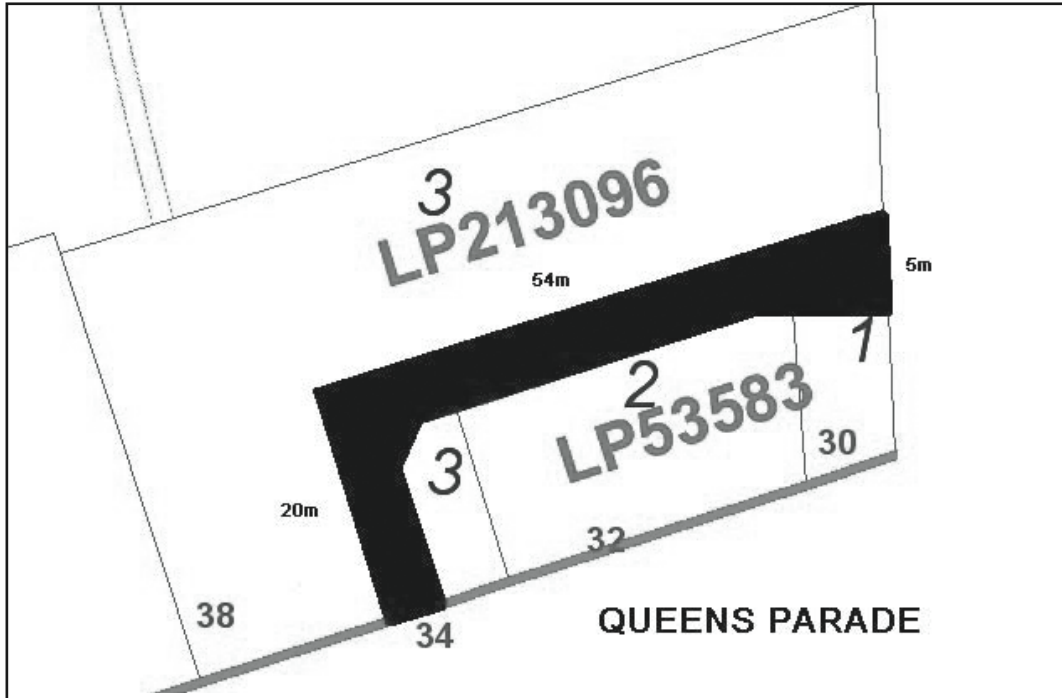

TIM JOHNSON  
Acting Chief Executive Officer



**Southern Grampians  
Shire Council**

Road Discontinuance

Notice is given pursuant to section 206 and schedule 10, clause 3 of the **Local Government Act 1989** that the Southern Grampians Shire Council, at its meeting held on 13 June 2007, resolved to discontinue the sections of road adjacent to the Henty Highway, Hamilton as shown hatched on the plans below and to sell the land from the roads by private treaty to the adjoining property owner.

The sections of road shown hatched are to be sold subject to the right, power or interest held by Powercor Australia Ltd in the roads in connection with any wires or cables under the control of that authority in or near the roads.

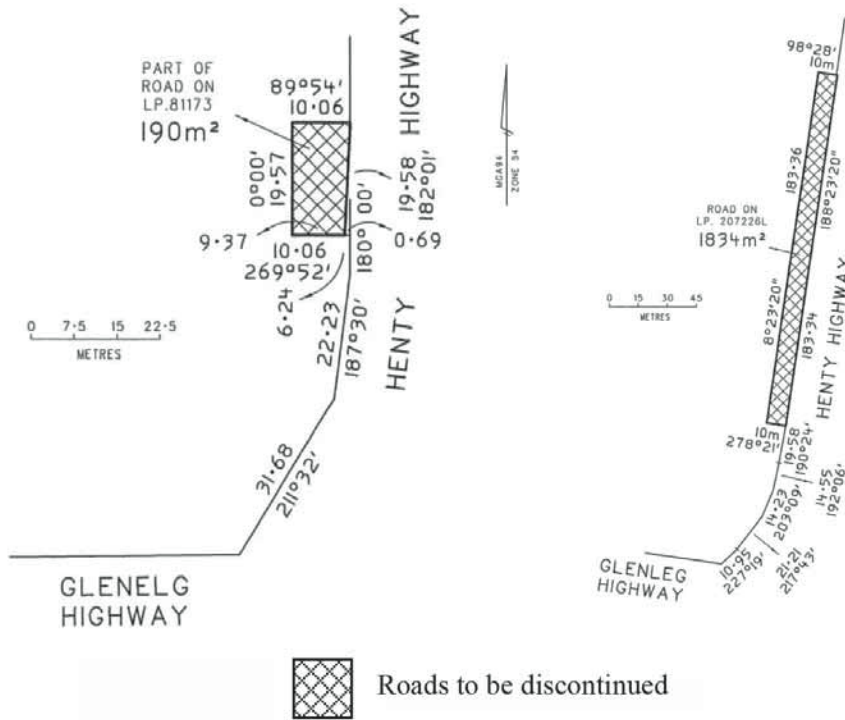

GRAHAM N. MOSTYN  
Chief Executive Officer

## MACEDON RANGES SHIRE COUNCIL

## Naming of Roads and Places Throughout Macedon Ranges Shire (Round 9)

I refer to the recent process of naming various roads and places throughout Macedon Ranges Shire.

Consultative processes were undertaken via advertisements in the local newspapers inviting comment/submissions on the naming of these roads. Various Authorities and nearby residents adjacent to the roads were also written to requesting feedback.

A number of submissions were received in response to this consultation process. A working group of Councillors has reviewed these submissions and made the following decisions.

Road	Name
Unnamed road off Gap Road, Riddles Creek.	To be named <b>Pear Lane</b> as suggested by one of the local residents as the property adjoining the road reserve was once a pear plantation.
Unnamed Government road off Cobb & Co. Road, Carlsrhue.	To be named <b>Farmer Road</b> . Early landowners of the area.
Unnamed Government road off Rutters Lane, between Three Chain Road and Carlsrhue Central Road, Carlsrhue.	To be named <b>Clerk Road</b> . Early landowners of the area.
Unnamed Government road off Salisbury Road, near Shepherds Hill Road, Lauriston.	To be named <b>Smithwick Road</b> . Early landowner of the area, former Shire Councillor, policeman, hotel owner and farmer.
Unnamed Government road off Fiddlers Green Road, Kyneton.	To be named <b>Old Station Road</b> . Close to old Redesdale Railway line and stations.

The necessary formal advertising/gazettal process will now be undertaken, relevant authorities notified and Council's records adjusted. Formal signage will also be installed shortly.

I would like to take this opportunity to thank those residents/associations who provided suggestions and should you require further information, please do not hesitate to contact me on 5422 0345.

SARAH MAYNE  
Administration Officer  
Council and Customer Service

WHITEHORSE CITY COUNCIL

Road Discontinuance

Pursuant to section 206 and schedule 10, clause 3 of the **Local Government Act 1989**, the Whitehorse City Council has formed the opinion that the road adjoining the rear of 3 to 11 Goulburn Street, 870 to 878 Station Street, 44 Shannon Street and adjacent 2B and 4 Wimmera Street, 39 and 41 Shannon Street and 42 and 44 Clyde Street, Box Hill North, as shown cross-hatched on the plans below, is not reasonably required as a road for public use and resolved to discontinue the road and to sell the land from the road by private treaty to the abutting property owners.

The road is to be sold subject to the right, power or interest held by both Whitehorse City Council and Yarra Valley Water Limited in the road in connection with any sewers, drains or pipes under the control of those authorities in or near the road.

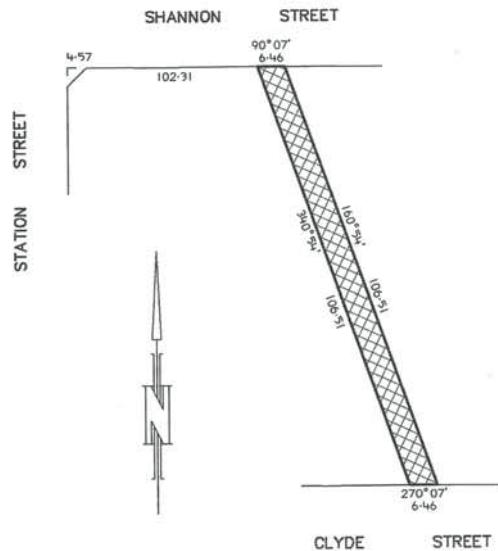

NOELENE DUFF  
Chief Executive Officer

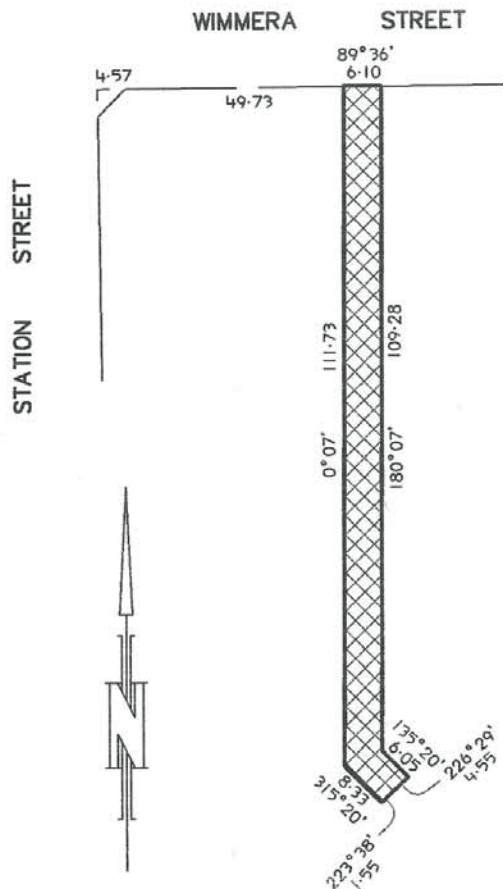

Notice of Intention to Amend the Current Hours of the Winter Foreshore Dog Restrictions

Notice is given that at its meeting on 17 December 2007, Council resolved to give public notice of its intention to amend the current hours of the Winter Foreshore Dog Restrictions. The current winter restrictions allow dogs to be off leash in Section B of the foreshore precinct before 10 am and after 3 pm. The Section B defined area is between Plummer Road, Mentone and Bay Street Car Park, Mordialloc and between the eastern sides of Mordialloc Creek to Old Post Office Lane, Carrum. The winter restrictions are in place from 1 April to 31 October each year.

It is proposed to amend the hours to allow dogs off leash daily from sunrise until 11 am and from 3 pm to sunrise.

Any person may make a written submission regarding the proposed amended hours for the Winter Foreshore Restrictions within 28 days of this notice. Submissions will be considered



in accordance with section 223 of the **Local Government Act 1989**. Submissions must be forwarded to Neil Sheppard, Team Leader Local Laws, City of Kingston, PO Box 1000, Mentone 3194. Any person who makes a written submission is entitled to make a verbal presentation in support of their submission before a Committee of Council. Any person who wishes to make such a presentation must so indicate in their submission.

JOHN NEVINS  
Chief Executive Officer

#### TOWONG SHIRE COUNCIL

##### Review of Road Management Plan

In accordance with the provisions of section 54 of the **Road Management Act 2004** and section 302 of the Road Management (General) Regulations 2005 notice is given that Towong Shire Council proposes to conduct a review of its Road Management Plan.

The Road Management Plan identifies the roads for which Council is responsible and documents the management systems required to ensure that road assets are effectively maintained to provide a safe road network for the community.

The purpose of the review is to review the inspection frequencies and response targets described in the plan and to make other amendments as appropriate.

The roads and classes of roads to which the plan applies are described in Council's Road Register and are roads that Council has determined are reasonably required for general public use.

A copy of the current Road Management Plan may be obtained from or inspected at the Towong Shire Offices, 32 Towong Street, Tallangatta 3700.

Any person may make a submission on the proposed review; submissions must be in writing and received within 28 days of the date of this notice.

Anyone wishing to obtain further information in relation to the proposed review should contact Gary Mawby, Director Technical Services, at the above address or by telephoning (02) 6071 5100 during normal office hours.

DAVID LAUGHER  
Chief Executive Officer

#### WARRNAMBOOL CITY COUNCIL

##### Full Day Public Holiday

Warrnambool City Council, pursuant to section 7(1)(b) of the **Public Holidays Act 1993**, has determined that Thursday 1 May 2008 be declared a Full Day Public Holiday in the Municipal District of the Warrnambool City Council for Warrnambool Cup Day.

BRUCE A. ANSON  
Chief Executive

#### Planning and Environment Act 1987

##### GREATER SHEPPARTON PLANNING SCHEME

##### Notice of Preparation of Amendment

##### Amendment C97

##### Authorisation A836

The Greater Shepparton City Council has prepared Amendment C97 to the Greater Shepparton Planning Scheme.

In accordance with section 9(2) of the **Planning and Environment Act 1987**, the Minister for Planning authorised the Greater Shepparton City Council as planning authority to prepare the Amendment.

The Amendment proposes to:

- rezone the land at 455 Verney Road from the Low Density Residential Zone (LDRZ) to the Special Use Zone 8 (SUZ8);
- rezone the land at 15 Grace Road and 685 New Dookie Road from the Farming Zone (FZ) to the Special Use Zone 8 (SUZ8); and
- include a new Schedule 8 to the Special Use Zone at Clause 37.01.

You may inspect the Amendment, any documents that support the Amendment and the explanatory report about the Amendment at the following locations: the office of the planning authority, 90 Welsford Street, Shepparton; the regional office of the Department of Planning and Community Development, 89 Sydney Road, Benalla; and at the Department of Planning and Community Development, Planning Information Centre, Ground Floor, 8 Nicholson Street, East Melbourne.

This can be done during office hours and is free of charge.

Any person who may be affected by the Amendment may make a submission to the planning authority.

The closing date for submissions is 11 February 2008. Submissions must be sent to the Greater Shepparton City Council, Locked Bag 1000, Shepparton 3632.

COLIN KALMS  
Manager Planning and Development

---

**Planning and Environment Act 1987**

HUME PLANNING SCHEME

Notice of Preparation of Amendment

Amendment C101

Authorisation A0880

The Hume City Council has prepared Amendment C101 to the Hume Planning Scheme.

In accordance with section 8A(3) of the **Planning and Environment Act 1987**, the Minister for Planning authorised the Hume City Council as planning authority to prepare the Amendment.

The land affected by the Amendment is located north-east of the intersection of David Munroe Drive and Somerton Road known as the Roxburgh Park Shopping Centre.

The Amendment proposes to increase the maximum combined leasable floor area for shop in the schedule to the Business 1 Zone for the site to 32,000. In addition the existing Development Plan Overlay which predominantly relates to residential development is proposed to be removed from the site. A new schedule to the Development Plan Overlay, specifically relating to the shopping centre is proposed. These changes are proposed in order to facilitate the expansion of the existing Roxburgh Park Shopping Centre.

You may inspect the Amendment, any documents that support the Amendment and the explanatory report about the Amendment at the following locations: the office of the planning authority, Hume City Council, Broadmeadows Office, 1079 Pascoe Vale Road, Broadmeadows; Hume City Council, Sunbury Office, 40 Macedon Street, Sunbury; Hume City Council, Craigieburn Office, Craigieburn Road West, Craigieburn; and at the Department

of Planning and Community Development, Planning Information Centre, Ground Floor, 8 Nicholson Street, East Melbourne.

This can be done during office hours and is free of charge.

Any person who may be affected by the Amendment may make a submission to the planning authority.

The closing date for submissions is 11 February 2008. A submission must be sent to Kim Giaquinta, Hume City Council, Strategic Planner, PO Box 119, Dallas, Vic. 3047.

DOMENIC ISOLA  
Chief Executive Officer

---

**Planning and Environment Act 1987**

MELBOURNE PLANNING SCHEME

Notice of Preparation of Amendment

Amendment C123

Authorisation A00856

The Melbourne City Council has prepared Amendment C123 to the Melbourne Planning Scheme at the request of the Department of Treasury and Finance.

In accordance with section 8A(3) of the **Planning and Environment Act 1987**, the Minister for Planning authorised the Melbourne City Council as planning authority to prepare the Amendment.

The Amendment applies to a site within Port Melbourne that is bounded by Cook Street to the north and the Westgate Freeway to the south described as Parcel 2 SP20332B.

The Amendment proposes to rezone the land from Road Zone 1 to the Industrial 1 Zone.

You may inspect the Amendment, any documents that support the Amendment and the explanatory report about the Amendment at the following locations: the office of the planning authority, City of Melbourne, Level 3, 240 Little Collins Street, Melbourne and at the Department of Planning and Community Development, Information Centre, Ground Floor, 8 Nicholson Street, East Melbourne.

This can be done during office hours and is free of charge.

Any person who may be affected by the Amendment may make a submission to the planning authority.

The closing date for submissions is 11 February 2008. A submission must be sent to David Mayes, Manager Strategic Planning and Sustainability, City of Melbourne, PO Box 1603, Melbourne, Vic. 3001.

DAVID MAYES  
Manager Strategic Planning and Sustainability

Creditors, next-of-kin and others having claims against the estate of any of the undermentioned deceased persons are required to send particulars of their claims to State Trustees Limited, ABN 68 064 593 148, 168 Exhibition Street, Melbourne, Victoria 3000, the personal representative, on or before 14 March 2008, after which date State Trustees Limited may convey or distribute the assets, having regard only to the claims of which State Trustees Limited then has notice.

BEST, Michael John, formerly of Wangaratta and District Nursing Home, 35–47 Green Street, Wangaratta, Victoria 3677, who died on 14 October 2007.

CASSAR, Vittorina, formerly of 90 Barnett Street, Kensington, but late of 9 Woodburn Place, Craigieburn, Victoria 3064, who died on 14 September 2007.

KELLER, Sarina, formerly of Villa 4, 8 Payne Street, Caulfield, but late of 33 Herbert Place, Albert Park, Victoria 3206, retired and who died on 25 February 2007.

McLEAN, Dorothy May, formerly of 138 Essex Street, West Footscray, but late of Lyrebird Village Hostel, 3 Neerim Street, Drouin, Victoria 3818, retired and who died on 2 September 2007.

REAY, Shirley Mavis, late of Unit 3, 24 Jackson Road, Highett, Victoria 3190, retired and who died on 29 August 2007.

ROBINSON, Vera Margaret, late of Eva Tilley Hostel, 24 Nicholson Street, Balwyn North, Victoria 3104, retired and who died on 30 August 2007.

ZAJEC, Thomas, late of 6 Dodds Road, Olinda, Victoria 3788, retired and who died on 10 July 2007.

Dated 4 January 2008

MARY AMERENA  
Manager  
Executor and Trustee Services

### Associations Incorporation Act 1981

#### SUB-SECTION 36E(5)

Notice is hereby given that the incorporation of the associations mentioned below is cancelled in accordance with section 36E (5) of the **Associations Incorporation Act 1981**.

Baw Baw Garden Lovers Inc.; Association of Social Clubs Inc.; Birralee Goulburn Valley Children's Festival Inc.; Weekend Wanderers Touring Club Inc.; Nyah & District Rural Badminton Association Inc.; Friends of the Mitta Valley Inc.; Floral Fields of Gippsland Inc.; Circolo Ricreativo Associazioni Dama Italiane Inc.; Westmeadows Pre-School Centre Inc.; Inner Wheel Club of Dandenong Inc.; Federation of Macedonian Travel Agents of Australia Inc.; Melbourne Model Boat Club Inc.; Cape Woolamai Residents and Ratepayers Association Inc.; Barnawartha Indigo Valley Community Action Group Inc.; Swan Hill Machine Knitters Club Inc.; Gladstone Park Pre-School Inc.; Wellington Bush Racing Carnival Inc.; Timboon Netball Association Inc.; Vipassana Insight Meditation Foundation Inc.; Master Plumbers' & Mechanical Services Association of Victoria Inc.; National Gas Contractors Association Inc.; National Metal Roofing and Wall Cladding Association Inc.; Heating & Cooling Association of Australia, Incorporated; National Plumbing and Mechanical Construction Industry Association Inc.; National Asbestos Removal and Re-Roofing Association Inc.; National Fire Services Association Inc.; Life Support International Inc.; Junior Chamber International Shepparton Inc.; Women's Lacrosse Victoria Inc.; Victorian Lacrosse Association Inc.

Dated 10 January 2008

MELANIE SABA  
Deputy Registrar of Incorporated Associations

### Cemeteries and Crematoria Act 2003

#### SECTION 41(1)

#### Notice of Approval of Cemetery Trust Fees and Charges

I, Pauline Ireland as Delegate of the Secretary to the Department of Human Services for the purposes of section 40(2) of the **Cemeteries and Crematoria Act 2003**, give notice that I have approved the scales of fees and charges

fixed by the public cemetery trusts listed in this notice. The approved scales of fees and charges will take effect from the date of publication in Government Gazette and will be published on the internet.

The Altona Memorial Park  
The Beechworth Cemetery Trust

PAULINE IRELAND  
Assistant Director  
Food Safety and Regulatory Activities

**Education and Training Reform Act 2006**

NOTICE OF MAKING OF ORDER UNDER  
SECTION 2.3.2(6)

An Order of the Minister for Education was made on 2 January 2008 under section 2.3.2(6) of the **Education and Training Reform Act 2006** to delete the election process clauses from the constituting Orders of all Government schools and provide for these in a separate Order, establishing provisions which will comprise part of the constituting Orders of the school councils of all Government schools.

BRONWYN PIKE, MP  
Minister for Education

**Education and Training Reform Act 2006**

NOTICE OF MAKING OF ORDER UNDER  
SECTION 2.3.2(6)

An Order of the Minister for Education was made on 2 January 2008 under section 2.3.2(6) of the **Education and Training Reform Act 2006** to amend the constituting Orders of the school councils of all Government schools to state the powers, duties and functions of a school council in the constituting Orders in accordance with the **Education and Training Reform Act 2006** and the Education and Training Reform Regulations 2007.

BRONWYN PIKE, MP  
Minister for Education

**Retirement Villages Act 1986**

SECTION 47

Extinguishment of Charge

I hereby declare that the Charge No. R597205N, pursuant to section 29 of the **Retirement Villages Act 1986**, registered on

17 October 1991 on Certificate of Title Volume 09858, Folio 236 under the **Transfer of Land Act 1958** is extinguished.

Dated 28 December 2007

DR DAVID COUSINS  
Director  
Consumer Affairs Victoria

**Retirement Villages Act 1986**

SECTION 48

Cancellation of Retirement Village Notice

I hereby declare that the Retirement Village Notice No. R297740L, pursuant to section 9 of the **Retirement Villages Act 1986**, registered on 15 April 1991 on Certificate of Title Volume 09858, Folio 236 under the **Transfer of Land Act 1958**, is cancelled.

Dated 28 December 2007

DR DAVID COUSINS  
Director  
Consumer Affairs Victoria

**Retirement Villages Act 1986**

SECTION 39

Cancellation of Retirement Village Notice

I hereby declare that the Retirement Village Notice number AB680432S, pursuant to section 9 of the **Retirement Villages Act 1986**, registered on 7 November 2002 on Certificate of Title Volume 10602, Folio 648 under the **Transfer of Land Act 1958** is cancelled.

Dated 28 December 2007

DR DAVID COUSINS  
Director  
Consumer Affairs Victoria

**Retirement Villages Act 1986**

SECTION 47

Extinguishment of Charge

I hereby declare that the charge No. V622338X, pursuant to section 29 of the **Retirement Villages Act 1986**, registered on 3 September 1998 on Certificate of Title Volume 10464, Folio 721 under the **Transfer of Land Act 1958** is extinguished.

Dated 28 December 2007

DR DAVID COUSINS  
Director  
Consumer Affairs Victoria

**Retirement Villages Act 1986**

SECTION 48

Cancellation of Retirement Village Notice

I hereby declare that the Retirement Village Notice No. V512184R, pursuant to section 9 of the **Retirement Villages Act 1986**, registered on 6 July 1998 on Certificate of Title Volume 10464, Folio 721 under the **Transfer of Land Act 1958**, is cancelled.

Dated 28 December 2007

DR DAVID COUSINS  
Director  
Consumer Affairs Victoria

**Land Acquisition and Compensation Act 1986**

FORM 7

S. 21  
Reg. 16

Notice of Acquisition

Compulsory Acquisition of Interest in Land

Latrobe City Council of 141 Commercial Road, Morwell ('the Authority') intends to acquire Reserve 1 on Plan of Subdivision PS601784L being part of the land in Certificate of Title Volume 10784 Folio 317. A copy of the plan in PS601784L is attached.

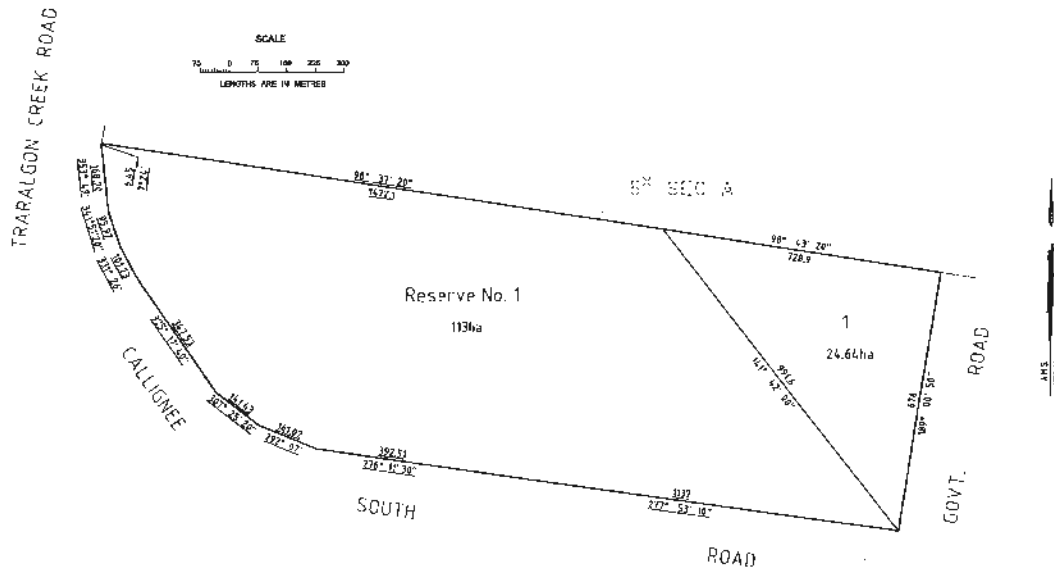

Published with the authority of Latrobe City Council.

Dated 10 January 2008

Signed for the Authority by  
PAUL BUCKLEY  
Chief Executive Officer

**Land Acquisition and Compensation Act 1986**  
FORM 7

S. 21  
Reg. 16

Notice of Acquisition  
Compulsory Acquisition of Interest in Land

Latrobe City Council of 141 Commercial Road Morwell ('the Authority') intends to acquire the leasehold interest of Grand Ridge Plantations Pty Ltd in Reserve 1 on Plan of Subdivision PS601784L, being part of the land in Certificate of Title Volume 10784 Folio 317. A copy of the plan in PS601784L is attached.

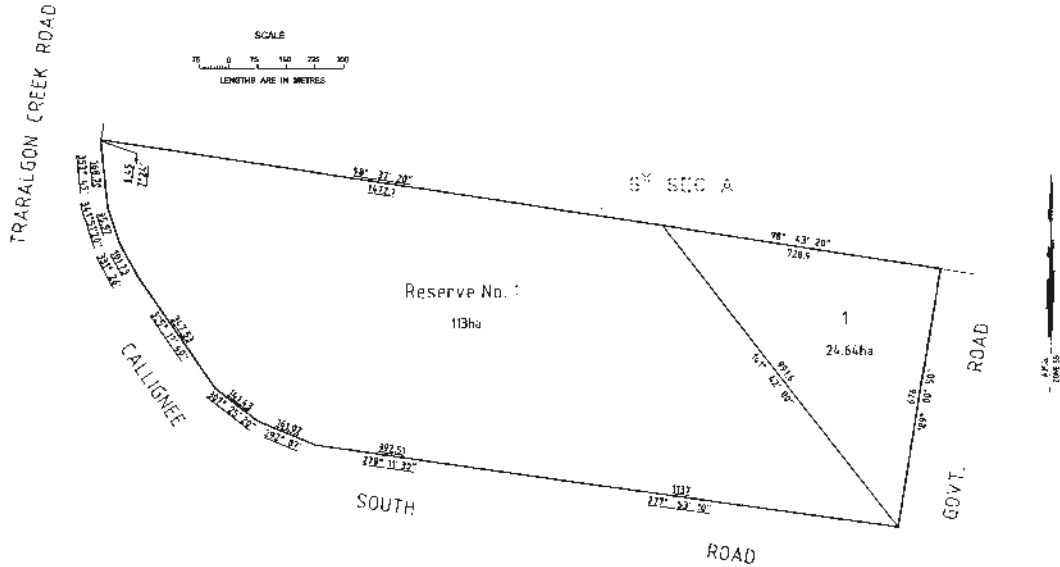

Published with the authority of Latrobe City Council.  
Dated 10 January 2008

Signed for the Authority by  
**PAUL BUCKLEY**  
Chief Executive Officer

**Land Acquisition and Compensation Act 1986**  
FORM 7

S. 21  
Reg. 16

Notice of Acquisition  
Compulsory Acquisition of Interest in Land

The Roads Corporation (VicRoads), declares that by this notice it acquires the following interest in the land described as Lot 15 on Plan of Subdivision 13051, lodged in the office of Titles and being part of Crown Portion 18, Parish of Langwarrin, comprising 5.0 square metres and being land described in Certificate of Title Volume 7267 Folio 279, shown as Parcel 1 on Survey Plan 21319B.

**Interest Acquired:** That of Pieter Johannes Minderman and all other interests.

Published with the authority of VicRoads.  
Dated 10 January 2008

For and on behalf of VicRoads  
**BERNARD TOULET**  
Director – Property Services

**Crown Land (Reserves) Act 1978**

**ORDER GIVING APPROVAL TO GRANT OF A LEASE UNDER  
SECTIONS 17D AND 17DA**

Under sections 17D and 17DA of the **Crown Land (Reserves) Act 1978**, I, Gavin Jennings MLC, Minister for Environment and Climate Change, being satisfied that there are special reasons which make the granting of a lease reasonable and appropriate in the particular circumstances and to do this will not be substantially detrimental to the use and enjoyment of any adjacent land reserved under the **Crown Land (Reserves) Act 1978**, approve the granting of a lease to Barwon Region Water Corporation by the Great Ocean Road Coast Committee Incorporated as the Committee of Management, for a term of twenty one (21) years for the purpose of Sewerage Pumping Station, Emergency Sewerage Storage Pipeline and associated Inspection Pits and Pipelines over the area of Crown land being part of the Torquay Public Purposes Reserves described in the Schedule below and, in accordance with section 17D(3)(a) of the **Crown Land (Reserves) Act 1978**, state that –

- (a) there are special reasons which make granting the lease reasonable and appropriate in the particular circumstances; and
- (b) to do this will not be substantially detrimental to the use and enjoyment of any adjacent land reserved under the **Crown Lands (Reserves) Act 1978**.

SCHEDULE

The land shown hatched, the land shown by the letters 'MH' and the land shown by the word 'PIPE' or 'PIPELINE' insofar as such 'PIPE' or 'PIPELINE' lie between the areas hatched and the areas shown as 'MH' on the following plan being part of Allotment 93A, No Section, Parish of Puebla being Crown land permanently reserved for Public purposes by Order in Council of 25 October 1880 and by Notice published in the Government Gazette of 29 October 1880, page 2661 and by further permanent reservation for the purpose of the Protection of the Coastline by Order in Council of 17 March 1981 and by Notice published in the Government Gazette of 25 March 1981, page 961.

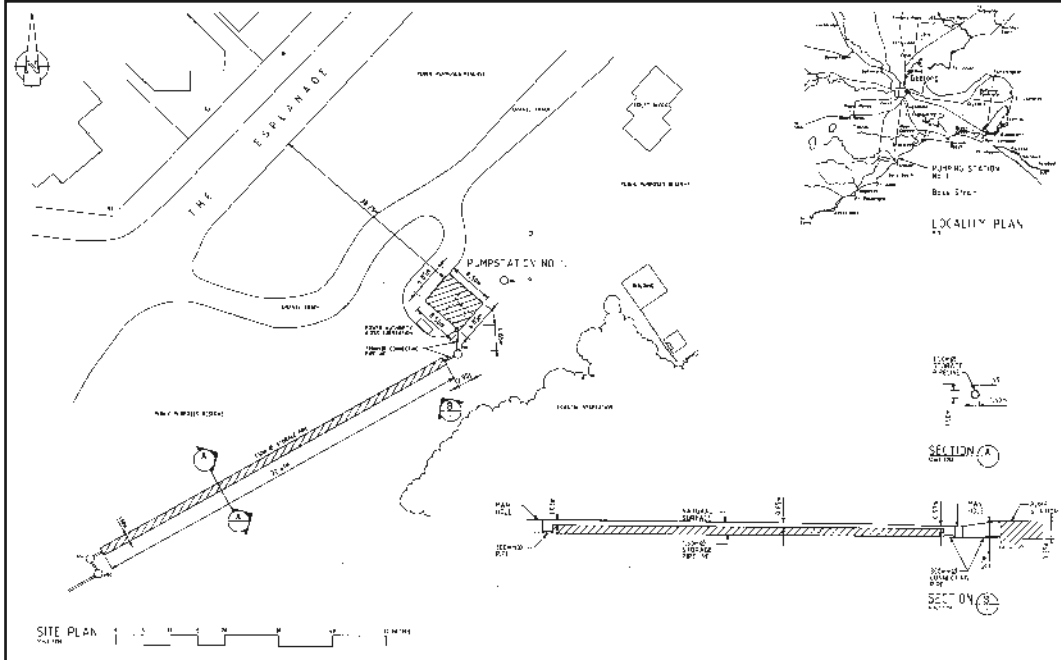

Dated 14 December 2007

File No. 0700258

GAVIN JENNINGS MLC  
Minister for Environment and Climate Change

**Geographic Place Names Act 1998**

## NOTICE OF INTENTION TO REGISTER A GEOGRAPHIC NAME

The Registrar of Geographic Names hereby gives notice of intention to register the undermentioned place name(s) and/or amendments to the boundaries of the undermentioned localities. Any objections to the proposal(s) should be made in writing (stating the reasons therefor) and lodged with the Registrar within 30 days of publication of this notice. If no objections are lodged within this period, any newly proposed names will become the official names and/or any proposed locality boundary amendments will be registered in the Register of Geographic Names.

File No.	Naming Authority	Place Name	Location
GPN 001110	Brimbank City Council	Keith Millar Oval	Located in J. R. Parsons Reserve at 30 Wright Street, Sunshine.
GPN 001111	Brimbank City Council	John McLeod Reserve	Currently named 'Deer Park Reserve' located at 783 Ballarat Road, Deer Park.

Office of the Registrar of Geographic Names

c/- **LAND VICTORIA**

17th Floor  
570 Bourke Street  
MELBOURNE 3000

JOHN E. TULLOCH  
Registrar of Geographic Names

**Geographic Place Names Act 1998**

## NOTICE OF REGISTRATION OF GEOGRAPHIC NAMES

The Registrar of Geographic Names hereby gives notice of the registration of the undermentioned place names.

File No.	Naming Authority	Place Name	Location
LA/12/0421	Minister for Environment and Climate Change	South Wharf, Southbank, Docklands	As shown on version 4.5 of the plan for the City of Melbourne and version 4.3 of the plan for the City of Port Phillip showing the locality names and boundaries. Copies of this plan may be inspected at the municipal offices or at the office of the Registrar of Geographic Names following registration.

Office of the Registrar of Geographic Names

c/- **LAND VICTORIA**

17th Floor  
570 Bourke Street  
MELBOURNE 3000

JOHN E. TULLOCH  
Registrar of Geographic Names



**Private Agents Act 1966**

NOTICE OF RECEIPT OF APPLICATIONS FOR  
COMMERCIAL SUB-AGENT'S LICENCE  
UNDER THE PROVISIONS OF THE **PRIVATE AGENTS ACT 1966**

I, the undersigned, being the Registrar of the Magistrates' Court at Dandenong hereby give notice that application, as under, has been lodged for hearing by the said Court on the date specified.

Any person desiring to object to any of such applications must:-

- (a) lodge with me a notice in the prescribed form of his/her objection and of the grounds thereof;
- (b) cause a copy of such notice to be served personally or by post upon the applicant at least three days before the hearing of the application; and
- (c) send or deliver
  - (i) where the objection is not made by the officer in charge of the police district in which the Court is situated – a copy of the notice to such officer; and
  - (ii) where the objection is not made by the Registrar or Deputy Registrar – a copy to the Registrar.

<i>Full Name of Applicant or in the case of a Firm or Corporation, of the Nominee</i>	<i>Place of Abode of Applicant or Nominee</i>	<i>Name of Firm or Corporation</i>	<i>Address for Registration</i>	<i>Type of Licence</i>	<i>Date of Hearing of Application</i>
Anthony James Wadelton	13 Marsh Grove, Berwick	Ann Elizabeth Gambetta	Suite 7, 9 Wilson Street, Berwick 3806.	Commercial Sub-Agent's Licence	21/02/08

Dated at Dandenong 3 January 2008

JULIE McCULLOCH  
Registrar  
Magistrates' Court of Victoria

**Private Agents Act 1966**

NOTICE OF RECEIPT OF APPLICATIONS FOR  
COMMERCIAL SUB-AGENT'S LICENCE  
UNDER THE PROVISIONS OF THE **PRIVATE AGENTS ACT 1966**

I, the undersigned, being the Deputy Registrar of the Magistrates' Court at Dandenong hereby give notice that applications, as under, have been lodged for hearing by the said Court on the date specified.

Any person desiring to object to any of such applications must:—

- (a) lodge with me a notice in the prescribed form of his/her objection and of the grounds thereof;
- (b) cause a copy of such notice to be served personally or by post upon the applicant at least three days before the hearing of the application; and
- (c) send or deliver
  - (i) where the objection is not made by the officer in charge of the police district in which the Court is situated – a copy of the notice to such officer; and
  - (ii) where the objection is not made by the Registrar or Deputy Registrar – a copy to the Registrar.

<i>Full Name of Applicant or in the case of a Firm or Corporation, of the Nominee</i>	<i>Place of Abode of Applicant or Nominee</i>	<i>Type of Licence</i>	<i>Date of Hearing of Application</i>
Melanie Bullard	65 Sheldon Drive, Berwick, Vic. 3806	Commercial Sub- Agents	5/03/08

Dated at Dandenong 7 January 2008

STEPHEN PAXINO  
Deputy Registrar  
Magistrates' Court of Victoria

**Planning and Environment Act 1987**  
**HOBSONS BAY PLANNING SCHEME**  
Notice of Approval of Amendment  
Amendment C64

The Minister for Planning has approved Amendment C64 to the Hobsons Bay Planning Scheme.

The Amendment comes into operation on the date this notice is published in the Government Gazette.

The Amendment makes a number of corrections to the planning scheme maps 5, 11, 18 and 19 as a result of the preparation, adoption and approval of the new format Port of Melbourne Planning Scheme amendment NPS1. The map changes include the addition and deletion of small parcels of land in the Hobsons Bay Planning Scheme and the application of appropriate zones to that land, in order to be consistent with the boundary of the 'Port of Melbourne Area', as defined under section 3 of the **Planning and Environment Act 1987**.

A copy of the Amendment can be inspected, free of charge, during office hours, at the offices of the Hobsons Bay City Council, 115 Civic Parade, Altona and at the Department of Planning and Community Development's website at [www.dpcd.vic.gov.au/planning](http://www.dpcd.vic.gov.au/planning).

GENEVIEVE OVERELL  
General Manager  
Planning, Heritage and Urban Design  
Department of Planning and  
Community Development

**Planning and Environment Act 1987**  
**LODDON PLANNING SCHEME**  
Notice of Approval of Amendment  
Amendment C21

The Minister for Planning has approved Amendment C21 to the Loddon Planning Scheme.

The Amendment comes into operation on the date this notice is published in the Government Gazette.

The Amendment is to introduce a specific provision under Clause 52.03 and apply an Incorporated Document to provide for the use and development of land for a Solar Energy Test Facility (SETF), to conduct research and development into solar energy technology and associated uses on land at the south-west

corner of the Calder Highway and Cemetery Road, Bridgewater, in accordance with the Incorporated Document.

A copy of the Amendment can be inspected, free of charge, during office hours, at the Department of Planning and Community Development, Loddon Mallee Regional Office, 1 Taylor Street, Epsom; the offices of the Loddon Shire Council, 41 High Street, Wedderburn; and at the Department of Planning and Community Development's website at [www.dpcd.vic.gov.au/planning](http://www.dpcd.vic.gov.au/planning).

GENEVIEVE OVERELL  
General Manager  
Planning, Heritage and Urban Design  
Department of Planning and  
Community Development

**Planning and Environment Act 1987**  
**MELBOURNE PLANNING SCHEME**  
Notice of Approval of Amendment  
Amendment C127

The Minister for Planning has approved Amendment C127 to the Melbourne Planning Scheme.

The Amendment comes into operation on the date this notice is published in the Government Gazette.

The Amendment makes a number of corrections to the planning scheme maps 6 and 7 as a result of the preparation, adoption and approval of the new format Port of Melbourne Planning Scheme amendment NPS1. The map changes include the addition and deletion of small parcels of land in the Melbourne Planning Scheme and the application of appropriate zones to that land, in order to be consistent with the boundary of the 'Port of Melbourne Area', as defined under section 3 of the **Planning and Environment Act 1987**.

A copy of the Amendment can be inspected, free of charge, during office hours, at the offices of the City of Melbourne, Level 3, 242 Little Collins Street, Melbourne and at the Department of Planning and Community Development's website at [www.dpcd.vic.gov.au/planning](http://www.dpcd.vic.gov.au/planning).

GENEVIEVE OVERELL  
General Manager  
Planning, Heritage and Urban Design  
Department of Planning and  
Community Development

**Planning and Environment Act 1987**  
PORT PHILLIP PLANNING SCHEME

Notice of Approval of Amendment  
Amendment C63

The Minister for Planning has approved Amendment C63 to the Port Phillip Planning Scheme.

The Amendment comes into operation on the date this notice is published in the Government Gazette.

The Amendment makes a number of corrections to Maps 1 and 2 as a result of the preparation, adoption and approval of the new format Port of Melbourne Planning Scheme amendment NPS1. The map changes include the addition and deletion of small parcels of land in the Port Phillip Planning Scheme, and the application of appropriate zones to that land, in order to be consistent with the boundary of the 'Port of Melbourne Area', as defined under section 3 of the **Planning and Environment Act 1987**.

A copy of the Amendment can be inspected, free of charge, during office hours, at the offices of the Port Phillip Council, 208–220 Bank Street, South Melbourne and at the Department of Planning and Community Development's website at [www.dpcd.vic.gov.au/planning](http://www.dpcd.vic.gov.au/planning).

GENEVIEVE OVERELL  
General Manager  
Planning, Heritage and Urban Design  
Department of Planning and  
Community Development

Area', as defined under section 3 of the **Planning and Environment Act 1987**.

A copy of the Amendment can be inspected, free of charge, during office hours, at the offices of the Melbourne City Council, 3rd Floor, Council House 2, 242 Little Collins Street, Melbourne and at the Department of Planning and Community Development's website [www.dpcd.vic.gov.au/planning](http://www.dpcd.vic.gov.au/planning).

GENEVIEVE OVERELL  
General Manager  
Planning, Heritage and Urban Design  
Department of Planning and  
Community Development

**Planning and Environment Act 1987**

PORT OF MELBOURNE  
PLANNING SCHEME

Notice of Approval of Amendment  
Amendment NPS1

The Minister for Planning has approved Amendment NPS1 to the Port of Melbourne Planning Scheme.

The Amendment comes into operation on the date this notice is published in the Government Gazette.

The Amendment NPS1 introduces a new format Port of Melbourne Planning Scheme consistent with the Victoria Planning Provisions and the boundary of the 'Port of Melbourne

This page was left blank intentionally

**SUBORDINATE LEGISLATION ACT 1994  
NOTICE THAT STATUTORY RULES ARE  
OBTAINABLE**

Notice is hereby given under Section 17(3) of the **Subordinate Legislation Act 1994** that the following Statutory Rules were first obtainable from Information Victoria, 505 Little Collins Street, Melbourne on the date specified:

- |   |   |
|---|---|
| <p>143. <i>Statutory Rule:</i> Fisheries (Western Port) (Amendment) Regulations 2007</p> <p><i>Authorising Act:</i> Fisheries Act 1995</p> <p><i>Date first obtainable:</i> 8 January 2008</p> <p><i>Code A</i></p>   | <p>147. <i>Statutory Rule:</i> Gene Technology (Further Amendment) Regulations 2007</p> <p><i>Authorising Act:</i> Gene Technology Act 2001</p> <p><i>Date first obtainable:</i> 8 January 2008</p> <p><i>Code B</i></p>                              |
| <p>144. <i>Statutory Rule:</i> Prevention of Cruelty to Animals (Amendment) Regulations 2007</p> <p><i>Authorising Act:</i> Prevention of Cruelty to Animals Act 1986</p> <p><i>Date first obtainable:</i> 8 January 2008</p> <p><i>Code A</i></p>  | <p>148. <i>Statutory Rule:</i> Radiation (Tanning Units Amendment) Interim Regulations 2007</p> <p><i>Authorising Act:</i> Radiation Act 2005</p> <p><i>Date first obtainable:</i> 8 January 2008</p> <p><i>Code A</i></p>                            |
| <p>145. <i>Statutory Rule:</i> Charter of Human Rights and Responsibilities (Public Authorities) (Interim) Regulations 2007</p> <p><i>Authorising Act:</i> Charter of Human Rights and Responsibilities Act 2006</p> <p><i>Date first obtainable:</i> 8 January 2008</p> <p><i>Code A</i></p> | <p>149. <i>Statutory Rule:</i> Transport (Taxi-cab Industry Accreditation) Regulations 2007</p> <p><i>Authorising Act:</i> Transport Act 1983</p> <p><i>Date first obtainable:</i> 8 January 2008</p> <p><i>Code C</i></p>                            |
| <p>146. <i>Statutory Rule:</i> Health (Pest Control) (Qualifications and Training) Regulations 2007</p> <p><i>Authorising Act:</i> Health Act 1958</p> <p><i>Date first obtainable:</i> 8 January 2008</p> <p><i>Code A</i></p>   | <p>150. <i>Statutory Rule:</i> Transport (Taxi-cab Network Service Provider Accreditation Exemptions) Regulations 2007</p> <p><i>Authorising Act:</i> Transport Act 1983</p> <p><i>Date first obtainable:</i> 8 January 2008</p> <p><i>Code A</i></p> |
|   | <p>151. <i>Statutory Rule:</i> Road Safety (Road Rules) (Young Drivers) Regulations 2007</p> <p><i>Authorising Act:</i> Road Safety Act 1986</p> <p><i>Date first obtainable:</i> 8 January 2008</p> <p><i>Code A</i></p>                             |
|   | <p>152. <i>Statutory Rule:</i> Road Safety (Drivers) (Young Drivers) Regulations 2007</p> <p><i>Authorising Act:</i> Road Safety Act 1986</p> <p><i>Date first obtainable:</i> 8 January 2008</p> <p><i>Code B</i></p>                                |

153. *Statutory Rule:* Road Safety (General) (Young Drivers) Regulations 2007  
*Authorising Act:* Road Safety Act 1986  
*Date first obtainable:* 8 January 2008  
*Code A*
154. *Statutory Rule:* Road Management (Works and Infrastructure) (Amendment) Regulations 2007  
*Authorising Act:* Road Management Act 2004  
*Date first obtainable:* 8 January 2008  
*Code A*
155. *Statutory Rule:* Road Safety (General) (Engine Reading Devices Amendment) Regulations 2007  
*Authorising Act:* Road Safety Act 1986  
*Date first obtainable:* 8 January 2008  
*Code A*
156. *Statutory Rule:* Road Safety (General) (Prescribed Devices and Other Amendments) Regulations 2007  
*Authorising Act:* Road Safety Act 1986  
*Date first obtainable:* 8 January 2008  
*Code A*

**PRICING FOR SPECIAL GAZETTE,  
 PERIODICAL GAZETTE AND  
 VICTORIAN LEGISLATION**

Retail price varies according to the number of pages in each Victoria Government Special Gazette, Victoria Government Periodical Gazette and Victorian legislation. The table below sets out the prices that apply.

<i>Price Code</i>	<i>No. of Pages (Including cover and blank pages)</i>	<i>Price*</i>
A	1–16	\$3.80
B	17–32	\$5.70
C	33–48	\$7.80
D	49–96	\$12.20
E	97–144	\$15.75
F	145–192	\$18.65
G	193–240	\$21.50
H	241–288	\$22.90
I	289–352	\$25.75
J	353–416	\$30.10
K	417–480	\$34.35
L	481–544	\$40.10
M	545–608	\$45.80
N	609–672	\$50.55
O	673–736	\$57.25
P	737–800	\$63.00

*\*All Prices Include GST*

**craftsmanpress**

The *Victoria Government Gazette* is published by The Craftsman Press Pty Ltd with the authority of the Government Printer for the State of Victoria

© State of Victoria 2008

This publication is copyright. No part may be reproduced by any process except in accordance with the provisions of the Copyright Act.

Address all enquiries to the Government Printer for the State of Victoria  
Level 2 1 Macarthur Street  
Melbourne 3002  
Victoria Australia

**How To Order**

	<b>Mail Order</b>	<b>Victoria Government Gazette</b> Level 1 520 Bourke Street Melbourne 3000 PO Box 1957 Melbourne 3001 DX 106 Melbourne
	<b>Telephone</b>	(03) 9642 5808
	<b>Fax</b>	(03) 9600 0478
	<b>email</b>	gazette@craftpress.com.au
	<b>Retail &amp; Mail Sales</b>	<b>Victoria Government Gazette</b> Level 1 520 Bourke Street Melbourne 3000 PO Box 1957 Melbourne 3001
	<b>Telephone</b>	(03) 9642 5808
	<b>Fax</b>	(03) 9600 0478
	<b>Retail Sales</b>	<b>Information Victoria</b> 505 Little Collins Street Melbourne 3000
	<b>Telephone</b>	1300 366 356
	<b>Fax</b>	(03) 9603 9920

Recommended Retail Price \$1.95 (includes GST)

ISSN 0819-5471



9 770819 552175