



Victoria Government Gazette

By Authority of Victorian Government Printer

No. G 1 Thursday 3 January 2013

www.gazette.vic.gov.au

GENERAL

TABLE OF PROVISIONS

Private Advertisements	
Dissolution of Partnership	
Pine Fresh Media	4
Estates of Deceased Persons	
Aitken Partners Pty Ltd	4
Anthony Rose & Mainwaring	4
Basile & Co. Pty Ltd	4
De Marco Lawyers	4
Donald & Ryan Lawyers	4
Fischer McCrae	4
Garden & Green	5
Kliger Partners	5
Lorraine Jones & Associates	5
Macpherson + Kelley	5
Septimus Jones & Lee	5
Tragear & Harris Lawyers	5
Warren, Graham & Murphy	6
Wills & Probate Victoria	6
Government and Outer Budget Sector	
Agencies Notices	7

Advertisers Please Note

As from 3 January 2013

The last Special Gazette was No. 2 dated 2 January 2013.

The last Periodical Gazette was No. 1 dated 14 June 2012.

How To Submit Copy

- See our webpage www.gazette.vic.gov.au
 - or contact our office on 8523 4601
between 8.30 am and 5.30 pm Monday to Friday
-

Copies of recent Special Gazettes can now be viewed at the following display cabinet:

- 1 Treasury Place, Melbourne (behind the Old Treasury Building)
-

**PUBLICATION OF THE VICTORIA GOVERNMENT GAZETTE (GENERAL)
AUSTRALIA DAY HOLIDAY 2013**

Please Note:

The Victoria Government Gazette (General) for AUSTRALIA DAY HOLIDAY week (G5/13) will be published on **Thursday 31 January 2013**.

Copy deadlines:

Private Advertisements **9.30 am on Friday 25 January 2013**

Government and Outer
Budget Sector Agencies Notices **9.30 am on Tuesday 29 December 2013**

Office Hours:

The Victoria Government Gazette Office is open during normal office hours over the holiday period, i.e. 8.30 am to 5.30 pm Monday to Friday, excluding public holidays.

Where urgent gazettal is required after hours, arrangements should be made with the Government Gazette Officer on 0419 327 321.

JENNY NOAKES
Government Gazette Officer

VICTORIA GOVERNMENT GAZETTE

Subscribers and Advertisers

Our contact details are as follows:

Victoria Government Gazette Office
Level 5, 460 Bourke Street
Melbourne, Victoria 3000

PO Box 1957
Melbourne, Victoria 3001

DX 106 Melbourne

Telephone: (03) 8523 4601
Fax: (03) 9600 0478
Mobile (after hours): 0419 327 321

Email: gazette@bluestargroup.com.au
Website: www.gazette.vic.gov.au

JENNY NOAKES
Government Gazette Officer

PRIVATE ADVERTISEMENTS

DISSOLUTION OF PARTNERSHIP

Notice is hereby given that the business partnership between Henry Isaac Aronsten and Lachlan Clarrie Tetlow-Stuart, trading as Pine Fresh Media, has been dissolved with effect from end of business 30 November 2012.

Re: ELAINE PEARL BUSH, deceased.

Creditors, next-of-kin and others having claims in respect of the estate of the deceased, who died on 20 September 2012, are required by the trustee, Kelly Hardstaff-Snow, to send particulars to her, care of the undersigned solicitors, by 3 March 2013, after which date the trustee may convey or distribute the assets, having regard only to the claims of which the trustee has notice.

AITKEN PARTNERS PTY LTD, solicitors,
Level 1, 114 William Street, Melbourne 3000.

IAN THOMAS FLANDERS, late of 60 Mills Street, Albert Park, Victoria, deceased.

Creditors, next-of-kin and others having claims in respect of the estate of the deceased, who died on 22 June 2012, are required by Bruce Adrian Moritz and David Ormond Owen, the executors of the Will of the deceased, to send particulars of their claims to them, care of the undermentioned solicitors, by 3 March 2013, after which date the executors may convey or distribute the assets, having regard only to the claims of which they then have notice.

ANTHONY ROSE & MAINWARING,
solicitors,
122 Bridport Street, Albert Park, Victoria 3206.

Re: Estate EMILY FRANCES MAUDSLEY, deceased.

In the estate of EMILY FRANCES MAUDSLEY, late of Northaven Home for the Aged, Shadforth Street, Kerang, Victoria, retired veterinary surgeon, deceased.

Creditors, next-of-kin and all others having claims against the estate of the said deceased are required by Charlotte Mary Brack, the executor of the Will of the said deceased, to send particulars of such claims to her, in care of the

undermentioned solicitors, within two months from the date of publication of this notice, after which date they will distribute the assets, having regard only to the claims of which they then have notice.

BASILE & CO. PTY LTD, legal practitioners,
46 Wellington Street, Kerang, Victoria 3579.

Re: VINCENZO IANNI, late of 8 Higinbotham Street, Coburg, Victoria, retired maintenance fitter, deceased.

Creditors, next-of-kin and others having claims in respect of the estate of the deceased, who died on 25 September 2011, are required by the trustee, Fortunato Ianni, to send particulars to the trustee, care of the undermentioned solicitors, within sixty days from the publication hereof, after which date the trustee may convey or distribute the assets, having regard only to the claims of which the trustee has notice.

DE MARCO LAWYERS,
794A Pascoe Vale Road, Glenroy 3046.

Re: JACQUELINE ANNE JONES, deceased.

Creditors, next-of-kin and others having claims in respect of the estate of JACQUELINE ANNE JONES, formerly of 6 Garden Street, Williamstown, and late of 657 Nepean Highway, Frankston, Victoria, merchandiser, deceased, who died on 23 June 2012, are required by the executor to send particulars of their claim to him, care of the undermentioned solicitors, by 11 June 2013, after which date the said executor will distribute the assets of the deceased, having regard only to the claims of which he then shall have notice.

DONALD & RYAN LAWYERS, solicitors,
304 High Street, Kew 3101.

MAGDALENA RUTH RUDOLPH, late of Arcare Nirvana Aged Care, 78 Nirvana Avenue, East Malvern, Victoria, home duties, deceased.

Creditors, next-of-kin and others having claims in respect of the estate of the deceased, who died on 30 July 2012, are required by the trustees, John Everard Rudolph and Craig James Crellin, to send particulars to the trustees

by 3 March 2013, care of the undermentioned solicitors, after which date the trustees may convey or distribute the assets, having regard only to the claims of which the trustees have notice.

FISCHER McCRAE, solicitors,
Level 3, 389 Lonsdale Street, Melbourne 3000.

Re: JUDITH EVELYN LONG, deceased.

Creditors, next-of-kin and others having claims in respect of the estate of the deceased, who died on 10 September 2012, are required by the trustee, Douglas Richard Long, to send particulars to him, care of the undersigned, by 28 February 2013, after which date the trustee may convey or distribute the assets, having regard only to the claims of which he then has notice.

GARDEN & GREEN, lawyers,
4 McCallum Street, Swan Hill, Victoria 3585.

Re: IAN EDWARD SMYTH, deceased.

Creditors, next-of-kin and others having claims in respect of the estate of the deceased, who died on 16 July 2012, are required by the trustees, Jo-anne Frances Moss and Bronwyn Margaret Good, to send particulars to them, care of the undersigned, by 28 February 2013, after which date the trustees may convey or distribute the assets, having regard only to the claims of which they then have notice.

GARDEN & GREEN, lawyers,
4 McCallum Street, Swan Hill, Victoria 3585.

Re: ANGELO KOUTKOS, late of 18A Palermo Street, South Yarra, Victoria 3141, deceased.

Creditors, next-of-kin and others having claims in respect of the estate of the deceased, who died on 11 December 2009, are required by Tina Tsetsenekos and Jim Koutkos, the personal representatives of the estate of the deceased, to send particulars to the undermentioned solicitors by 31 March 2013, after which date the personal representatives may convey or distribute the assets, having regard only to the claims of which they then have notice.

KLIGER PARTNERS, lawyers,
Level 2, 280 Queen Street, Melbourne,
Victoria 3000.

Re: PEGGY McWHINNEY, late of Regis Aged Care, Central Road, Blackburn, Victoria, home duties, deceased.

Creditors, next-of-kin and others having claims in respect of the estate of the deceased, who died on 26 September 2012, are required by the trustee, Brian Redmond Smyth, of 900 Main Road, Eltham, Victoria, notary public, to send particulars to the trustee by 6 June 2013, after which date the trustee may convey or distribute the assets, having regard only to the claims of which the trustee has notice.

LORRAINE JONES & ASSOCIATES, solicitors,
900 Main Road, Eltham 3095.

Re: THELMA ROSE BLACK, late of Ranelagh Gardens, 1 St Johns Lane, Mount Eliza, Victoria, retired, deceased.

Creditors, next-of-kin and others having claims in respect of the estate of the deceased, who died on 9 August 2012, are required by the trustee, Jessie Anne Williams, care of 40-42 Scott Street, Dandenong, Victoria 3175, to send particulars to the trustee by 3 March 2013, after which date the trustee may convey or distribute the assets, having regard only to the claims of which the trustee has notice.

MACPHERSON + KELLEY, lawyers,
40-42 Scott Street, Dandenong 3175.

Re: CHARLES EDWARD RAGG, deceased.

Creditors, next-of-kin and others having claims in respect of the estate of the deceased, who died on 8 July 2012, are required by Leslie Arthur Ragg, the trustee of the estate of the deceased, to send particulars of their claims to him, care of the undermentioned solicitors, by 1 March 2013, after which date the trustee may convey or distribute the assets, having regard only to the claims of which the trustee has notice.

SEPTIMUS JONES & LEE, solicitors,
Level 5/99 William Street, Melbourne 3000.

Re: KENNETH BRUCE CORNWELL, late of 46 Shasta Avenue, Brighton East, Victoria 3187, surgeon/medical doctor, deceased.

Creditors, next-of-kin and others having claims in respect of the estate of the deceased, who died on 23 October 2012, are required by the executor, Bradley James Cornwell, to send

particulars to him, care of the undermentioned solicitors, by 6 March 2013, after which date the executor may convey and distribute the assets, having regard only to the claims of which he then has notice.

TRAGEAR & HARRIS LAWYERS,
1/23 Melrose Street, Sandringham 3191.

Estate of SUZANNE MARY BOWERMAN, late of 21 Maude Street, Bairnsdale, Victoria, home duties, deceased.

Creditors, next-of-kin and others having claims in respect of the estate of the deceased, who died on 13 April 2012, are required by the administrators, Bruce Harry Doherty and Kasey Maree Bowerman, to send particulars to them, care of Warren, Graham and Murphy, 119 Main Street, Bairnsdale, Victoria 3875, by 20 March 2013, after which date the administrators may convey or distribute the assets, having regard only to the claims of which they then have notice.

Re: JOHN LAWRENCE GRAHAM, late of 54/25 Veronica Street, Northcote, Victoria.

Creditors, next-of-kin and others having claims in respect of the estate of the deceased, who died on 6 October 2012, are required to send particulars of their claims to the executor, care of Level 3, 20–22 McKillop Street, Melbourne, Victoria 3000, by 19 March 2013, after which date the executor may convey or distribute the assets, having regard only to the claims of which he may then have notice.

WILLS & PROBATE VICTORIA, lawyers,
Level 3, 20–22 McKillop Street, Melbourne 3000.

Re: VENETIA LESLIE GRAHAM, late of 54/25 Veronica Street, Northcote, Victoria.

Creditors, next-of-kin and others having claims in respect of the estate of the deceased, who died on 7 September 2012, are required to send particulars of their claims to the executor, care of Level 3, 20–22 McKillop Street, Melbourne, Victoria 3000, by 19 March 2013, after which date the executor may convey or distribute the assets, having regard only to the claims of which he may then have notice.

WILLS & PROBATE VICTORIA, lawyers,
Level 3, 20–22 McKillop Street, Melbourne 3000.

**GOVERNMENT AND OUTER BUDGET
SECTOR AGENCIES NOTICES**

Planning and Environment Act 1987

MORNINGTON PENINSULA
PLANNING SCHEME

Notice of Preparation of Amendment

Amendment C170

Authorisation A02420

The Mornington Peninsula Shire Council has prepared Amendment C170 to the Mornington Peninsula Planning Scheme.

In accordance with section 8A(3) of the **Planning and Environment Act 1987**, the Minister for Planning authorised the Mornington Peninsula Shire Council as planning authority to prepare the Amendment.

The land affected by the Amendment is 4–6 Rannoch Avenue, Mount Eliza.

The Amendment proposes to apply a Heritage Overlay to the land, insert an associated entry in the Schedule to the Heritage Overlay and include an associated heritage citation report as a reference document in the Mornington Peninsula Planning Scheme.

You may inspect the Amendment, any documents that support the Amendment and the explanatory report about the Amendment, free of charge, at the following locations: during office hours, at the offices of the planning authority, Mornington Peninsula Shire Council: 90 Besgrove Street, Rosebud; 2 Queen Street, Mornington; 21 Marine Parade, Hastings; on the Shire's website, www.mornpen.vic.gov.au; and at the Department of Planning and Community Development website, www.dpcd.vic.gov.au/planning/publicinspection (from 3 January 2013).

Any person who may be affected by the Amendment may make a submission to the planning authority.

The closing date for submissions is 4 February 2013. A submission must be sent to the Manager Strategic Planning, Mornington Peninsula Shire, Private Bag 1000, Rosebud 3939.

ALLAN COWLEY
Manager – Strategic Planning

Creditors, next-of-kin and others having claims against the estate of any of the undermentioned deceased persons are required to send particulars of their claims to State Trustees Limited, ABN 68 064 593 148, of 168 Exhibition Street, Melbourne, Victoria 3000, the personal representative, on or before 27 February 2013, after which date State Trustees Limited may convey or distribute the assets, having regard only to the claims of which State Trustees Limited then has notice.

BERRY, Stanley Arthur Ambrose, late of Bupa Bonbeach, 53–59 Broadway, Bonbeach, Victoria 3196, pensioner, deceased, who died on 29 August 2012.

DALE, Judith Ellen, late of Old Colonists Society, 20 Rushall Crescent, Fitzroy North, Victoria 3068, retired, deceased, who died on 2 September 2012.

DAVIES, Catherine, late of St Judes's Aged Care Facility, 381–403 Narre Warren Road, Narre Warren, Victoria 3805, deceased, who died on 6 November 2012.

ENDZINS, Aivars, late of Gatwick Hotel, 34 Fitzroy Street, St Kilda, Victoria 3182, deceased, who died on 19 October 2012.

HODGSON, Ronald Kenneth, late of Corangamarah, 2–28 Connor Street, Colac, Victoria 3250, deceased, who died on 14 October 2012.

JONES, Stuart Edward, late of 13 Jackson Street, South Morang, Victoria 3752, deceased, who died on 2 February 2012.

LEE, Peter Tiger, late of 13 Lorica Avenue, Broadmeadows, Victoria 3047, deceased, who died on 15 September 2012.

REEVES, Colin Arthur, late of Unit 22, 171 Kent Street, Ascot Vale, Victoria 3032, retired, deceased, who died on 19 June 2012.

SCHAMBRE, Mathias, late of 107 Maxweld Street, Ardeer, Victoria 3022, deceased, who died on 16 February 2004.

WOODS, Ethel Elizabeth, late of Victoria Grange, 502–514 Burwood Highway, Vermont South, Victoria 3133, retired, deceased, who died on 26 August 2012.

Dated 19 December 2012

STEWART MacLEOD
Manager

Creditors, next-of-kin and others having claims against the estate of any of the undermentioned deceased persons are required to send particulars of their claims to State Trustees Limited, ABN 68 064 593 148, of 168 Exhibition Street, Melbourne, Victoria 3000, the personal representative, on or before 28 February 2013, after which date State Trustees Limited may convey or distribute the assets, having regard only to the claims of which State Trustees Limited then has notice.

HARTLAND, George William, late of Unit 7, 105 Park Road, Cheltenham, Victoria 3192, retired, deceased, who died on 25 August 2012.

ARMITAGE, Joan Millard, late of Lovell House, 389 Alma Road, Caulfield North, Victoria 3161, retired, deceased, who died on 27 August 2012.

TONGE, Lenore Florance, late of Room 30, Lovell House, 389 Alma Road, Caulfield, Victoria 3162, retired, deceased, who died on 6 July 2012.

CHRETIEN, Marie Monique Doreen, late of Flat 6, 43–45 Justin Avenue, Glenroy, Victoria 3046, who died on 26 February 2012.

CAMERON, Mavis Lesley, late of Werribee Terrace Aged Care, 8 Russell Street, Werribee, Victoria 3030, deceased, who died on 20 October 2007.

CRAWLEY, Peter Francis, late of Trinity Garden Aged Care, 34 Brooklyn Road, Melton South, Victoria 3338, deceased, who died on 10 March 2012.

Dated 20 December 2012

STEWART MacLEOD
Manager

Creditors, next-of-kin and others having claims against the estate of any of the undermentioned deceased persons are required to send particulars of their claims to State Trustees Limited, ABN 68 064 593 148, of 168 Exhibition Street, Melbourne, Victoria 3000, the personal representative, on or before 3 March 2013, after which date State Trustees Limited may convey or distribute the assets, having regard only to the claims of which State Trustees Limited then has notice.

AMZALAK, Albert David, late of Sacred Heart Mission, 101 Grey Street, St Kilda, Victoria 3182, retired, deceased, who died on 8 August 2012.

BEARD, Enid Joy, late of Pattison House Hostel, 28 Britt Street, Ouyen, Victoria 3490, deceased, who died on 5 October 2012.

BERKELEY, Lorna, late of Unit 99, 6 Melville Park Drive, Berwick, Victoria 3806, deceased, who died on 10 August 2012.

CAHILL, Allan Leslie, late of 58 Darby Road, Waranga Shores, Victoria 3612, deceased, who died on 21 August 2012.

GOOCH, Amy May, late of Chaffey Aged Care, Main Avenue, Merbein, Victoria 3505, retired, deceased, who died on 10 August 2012.

HOLMES, Jack Frederick, late of 20/150 Inkerman Street, St Kilda, Victoria 3182, deceased, who died on 13 July 2012.

IROVIC, Tomas, late of Ardeer Nursing Home, 30 North Street, Ardeer, Victoria 3022, deceased, who died on 27 July 2012.

LENCH, Brian, late of Unit 2, 28 Pratt Street, Ringwood, Victoria 3134, deceased, who died on 14 December 2011.

PREZELJ, Nicolaj, late of Glen Gowrie Aged Care, 54 Box Forest Road, Glenroy, Victoria 3046, deceased, who died on 29 August 2012.

PRICE, Lorraine, late of St John's Retirement Village, 138 Williams Road, Wangaratta, Victoria 3677, Retired deceased who died on 4 October 2012.

VOUKELATOS, Peter, late of St Basil's Home For The Aged, 24–36 Lorne Street, Fawkner, Victoria 3060, deceased, who died on 20 August 2012.

WRIGHT, Dorothy Maie, late of Cabrini Ashwood, 54 Queens Parade, Ashwood, Victoria 3147, home duties, deceased, who died on 19 August 2012.

Dated 28 December 2012

STEWART MacLEOD
Manager

EXEMPTION

Application No. A221/2012

The Victorian Civil and Administrative Tribunal has considered an application pursuant to section 89 of the **Equal Opportunity Act 2010** (the Act) by the State of Victoria – Department of Early Childhood Development

(the applicant). The application for exemption is to enable the applicant to advertise for and employ only a male in the role of integration aide to work with a male student with disabilities (the exempt conduct).

Upon reading the material filed in support of this application, including affidavit material and having regard to submissions made by the applicant and the Victorian Equal Opportunity and Human Rights Commission, the Tribunal is satisfied that it is appropriate to grant an exemption from sections 16, 107 and 182 of the Act to enable the applicant to engage in the exempt conduct.

In granting this exemption the Tribunal noted:

- The school which the student attends currently employs one full time integration aide and four part time integration aides, all of whom are female. The school also employs three temporary part-time aides who currently perform the role which is the subject of this application.
- At the end of 2012 the school will have a vacancy for one integration aide and it is proposed that a male be employed to work with the male student. The integration aide's role includes providing assistance with the curriculum and learning, communication with peers and students, preparation of materials, movement around the school and other physical care such as assisting with meals and medications and changing clothes. To preserve the student's dignity and decency, it is appropriate that the personal care and assistance he requires be provided by a male integration aide.
- Since the student was enrolled at the school in 2010, his aggressive sexualised behaviour has increased in frequency and severity. He has, on a number of occasions, grabbed and inappropriately touched female integration aides and has made inappropriate sexualised comments to those aides. Some of these incidents have been very serious. Other students who have witnessed this behaviour are also adversely affected. Since male integration aides have commenced working with the student, the situation has improved and having such an arrangement continue is considered to be in the best interests of the staff and other students and consistent with the school's duty to keep staff and students safe.
- Importantly, if the school is unable to employ a male integration aide, it is possible that the student will have limited access to education as he may be removed from classes and/or from time to time be suspended due to his behaviour. Other strategies to manage the behaviour have had limited effect although they will continue to be used. The applicant believes that, if a male integration aide is available to work with the student, he will have better access to educational opportunities, learn to manage in a co-educational setting and be able to better engage with his peers and teaching staff of both genders.
- No current exemption already applies to the exempt conduct. The Act contains exceptions relating to care of children in order to protect their physical, psychological or emotional wellbeing (section 25) and where there is a genuine occupational requirement for an employee to be of one gender (section 26). Given the range of responsibilities of the integration aide, I am not satisfied that all of the aspects of the role fall within either exception. Further, on the material available, I am not satisfied that the exception regarding compliance with other laws contained in section 75 applies. In the circumstances, in the absence of an exemption the exempt conduct may amount to prohibited discrimination.
- When making decisions about exemptions, the Tribunal is required to give proper consideration to relevant human rights as set out in the **Charter of Human Rights and Responsibilities Act 2006** (Charter). Arguably, this exemption limits the right to equality and in particular the right to equal and effective protection against discrimination of women who would wish to be employed in the integration aide role. The right of children, without discrimination, to such protection as is in their best interests may also arise in respect of the student or other students at the school. I am satisfied that, in the circumstances discussed above, including the possible adverse affects on the student's education if the exemption is not granted, the limit imposed by this exemption is reasonable and justified under the Charter.

The Tribunal hereby grants an exemption from the operation of sections 16, 107 and 182 of the Act to enable the applicant to engage in the exempt conduct.

This exemption is to remain in force from the day on which notice of the exemption is published in the Government Gazette until 31 December 2015.

Dated 19 December 2012

A. DEA
Member

Aboriginal Lands Act 1970

SUB-SECTION 23C(2)

Whereas, in accordance with the provisions of sub-section 23C(2) of the **Aboriginal Lands Act 1970**, the Minister for Aboriginal Affairs may extend the period of appointment of an Administrator of the Lake Tyers Aboriginal Trust.

I, Jeanette Powell, Minister for Aboriginal Affairs, hereby extend the appointment of the following person as Administrator of the Lake Tyers Aboriginal Trust. This extension of appointment applies for a period of six (6) months, unless revoked sooner, from 31 December 2012.

Mr Simon Wallace-Smith of Deloitte, 550 Bourke Street, Melbourne, Victoria 3001.

Dated 3 January 2013

JEANETTE POWELL
Minister for Aboriginal Affairs

Adoption Act 1984

Under the functions and powers assigned to me by the Secretary to the Department of Human Services under section 21(3) of the **Adoption Act 1984** in relation to Part 2, Division 1 of the Adoption Regulations (1998), I, Mariela Diaz, give approval to the following person under section 21(2) of the **Adoption Act 1984** as Deputy Principal Officer.

Name: Ms Kathryn McLeod

MARIELA DIAZ
Director, Child Protection
South Division

Cemeteries and Crematoria Act 2003

SECTION 41(1)

Notice of Approval of Cemetery Trust Fees and Charges

I, Bryan Crampton, as Delegate of the Secretary to the Department of Health for the purposes of section 40(2) of the **Cemeteries and Crematoria Act 2003**, give notice that I have approved a scale of fees and charges fixed by the following cemetery trust. The approved scale(s) of fees and charges will take effect from the date of publication of this notice in the Government Gazette and will be published on the internet.

The Bendigo Cemeteries Trust

Dated 19 December 2012

BRYAN CRAMPTON
Manager

Cemeteries and Crematoria Regulation Unit

Cemeteries and Crematoria Act 2003

SECTION 41(1)

Notice of Approval of Cemetery Trust Fees and Charges

I, Bryan Crampton, as Delegate of the Secretary to the Department of Health for the purposes of section 40(2) of the **Cemeteries and Crematoria Act 2003**, give notice that I have approved the scale/s of fees and charges fixed by the following cemetery trust/s. The approved scale of fees and charges will take effect from the date of publication of this notice in the Government Gazette and will be published on the internet.

The Cemetery Trust/s

Nyah

Dated 20 December 2012

BRYAN CRAMPTON
Manager

Cemeteries and Crematoria Regulation Unit

Country Fire Authority Act 1958

DECLARATION OF FIRE DANGER PERIOD

In pursuance of the powers conferred by section 4 of the **Country Fire Authority Act 1958**, I, Mick Bourke, Chief Executive Officer of the Country Fire Authority, after consultation with the Secretary to the Department of

Sustainability and Environment, hereby declare the following periods to be the Fire Danger Period in the municipal districts of the municipalities or parts of municipalities specified, commencing on the dates shown and, unless varied by subsequent declaration, ending at 0100 hours on 1 May 2013.

To commence from 0100 hours on 7 January 2013:

- Yarra Ranges Shire Council (those portions not included in the Metropolitan Fire District)
- Knox City Council
- Manningham City Council (those portions not included in the Metropolitan Fire District)
- Maroondah City Council (those portions not included in the Metropolitan Fire District)
- Baw Baw Shire Council
- South Gippsland Shire Council
- Bass Coast Shire Council
- Cardinia Shire Council
- Casey City Council
- Frankston City Council
- Greater Dandenong City Council
- Kingston City Council (those portions not included in the Metropolitan Fire District)
- Mornington Peninsula Shire Council
- French Island.

MICK BOURKE
Chief Executive Officer

PUBLIC NOTICE CONCERNING NEIGHBOURHOOD SAFER PLACES

Two public land reserves established under the **Crown Land (Reserves) Act 1978** have been identified as meeting the Country Fire Authority Assessment Guidelines for neighbourhood safer places. As the Minister responsible for the **Crown Land (Reserves) Act 1978**, I consent to the use of the following reserves as Neighbourhood Safer Places.

Reserve No.	Municipality	Township Name	General Location	Description
0511871	Colac Otway Shire	Apollo Bay	Nelson Street, Apollo Bay 3233	Apollo Bay Foreshore
P020160	Hindmarsh Shire Council	Dimboola	204 High Street, Dimboola 3414	Apex Park, Dimboola

Dated 10 December 2012

JENNY PEQUIGNOT
Executive Director, Land Division

Education and Training Reform Act 2006
DIRECTION TO BOARDS OF TAFE INSTITUTES ON EXECUTIVE
REMUNERATION AND CLASSIFICATION

PURPOSE

1. The purpose of this Direction is to require boards of TAFE institutes to adjust the remuneration range payable to the Chief Executive Officer of a TAFE institute, and the classification of declared management staff positions in a TAFE institute in accordance with:
 - a) the institute Annual Income (Less Capital) Ranges; and
 - b) Remuneration Ranges in line with the 2012 executive remuneration review adjustment approved by the Premier of Victoria, as advised by the Government Sector Executive Remuneration Panel and effective from 1 July 2012.

INTERPRETATION

2. In this Direction, unless stated otherwise:

Act means the **Education and Training Reform Act 2006**;

TAFE institute does not include the TAFE division of a university with a TAFE division;

words used have the same meaning as in the Act.

APPLICATION AND REVOCATION OF PREVIOUS DIRECTIONS

3. This Direction is issued to the board of each TAFE institute established under the Act, and replaces those parts of previous Directions dealing with the subject matter in paragraph 6, which parts are hereby revoked.

FROM 1 JANUARY 2013

4. From 1 January 2013, a reference to a board of a TAFE institute in this Direction shall be read as meaning the TAFE institute.

(Note: on 1 January 2013, Parts 4 and 5 of the **Education Legislation Amendment (Governance) Act 2012** will commence operation. That Act changes the legal structure of boards and TAFE institutes, so that from that date, the institute, instead of the board, will be a legal entity vested with various functions and powers.

This clause mirrors the effect of transitional section 33 of the above Act, which in summary, vests the TAFE institute with the relevant functions and powers from 1 January 2013).

AUTHORITY FOR DIRECTION AND COMMENCEMENT

5. This Direction is issued pursuant to section 5.2.1(2)(b) of the Act, and commences on the date it is signed.

CHIEF EXECUTIVE OFFICERS OR EXECUTIVE OFFICERS

6. The board of a TAFE institute must assign one of the following classifications to each declared management staff position of the TAFE institute in accordance with the following:

Chief Executive Officer Level 1 (CEO 1)

Chief Executive Officer Level 2 (CEO 2)

Executive Officer (EO)

The board of a TAFE institute must determine the classification level of a Chief Executive Officer in accordance with the following table:

Institute Annual Income (Less Capital) Ranges	Classification Level	Remuneration Ranges		
		Minimum	Mid-Point	Maximum
Greater than \$107.7 Million	CEO 1	\$238,478	\$267,317	\$296,155
Up to \$107.7 Million	CEO 2	\$196,754	\$217,615	\$238,477
	EO	\$141,667		

Dated 21 December 2012

THE HON. PETER HALL, MLC
 Minister for Higher Education and Skills

Education and Training Reform Act 2006

**DIRECTION TO GOVERNING BOARDS OF ADULT EDUCATION INSTITUTIONS ON
EXECUTIVE REMUNERATION AND CLASSIFICATION**

PURPOSE

1. The purpose of this Direction is to require boards of adult education institutions to adjust the remuneration range payable to the Chief Executive Officer of the institution and executive officers in accordance with:
 - a) the institution Annual Income (Less Capital) Ranges; and
 - b) Remuneration Ranges in line with the 2012 executive remuneration review adjustment approved by the Premier of Victoria, as advised by the Government Sector Executive Remuneration Panel and effective from 1 July 2012.

INTERPRETATION

2. In this Direction, unless stated otherwise:

Act means the **Education and Training Reform Act 2006**;

Institution means an adult education institution established under the Act;

words used have the same meaning as in the Act.

APPLICATION AND REVOCATION OF PREVIOUS DIRECTIONS

3. This Direction is issued to the board of each institution, and replaces those parts of previous Directions dealing with the subject matter in paragraph 6, which parts are hereby revoked.

FROM 1 JANUARY 2013

4. From 1 January 2013, a reference to a board of an institution in this Direction shall be read as meaning the adult education institution.

(Note: on 1 January 2013, Parts 4 and 5 of the **Education Legislation Amendment (Governance) Act 2012** will commence operation. That Act changes the legal structure of boards and adult education institutions, so that from that date, the institution, instead of the board, will be a legal entity vested with various functions and powers.

This clause mirrors the effect of transitional section 33 of the above Act, which in summary, vests the institution with the relevant functions and powers from 1 January 2013.)

AUTHORITY FOR DIRECTION AND COMMENCEMENT

5. This Direction is issued pursuant to section 5.2.1(2)(b) of the Act, and commences on the date it is signed.

CHIEF EXECUTIVE OFFICERS OR EXECUTIVE OFFICERS

6. The board of an institution must assign one of the following classifications to each executive officer of the institution in accordance with the following:

Chief Executive Officer Level 1 (CEO 1)

Chief Executive Officer Level 2 (CEO 2)

Executive Officer (EO)

The board of an institution must determine the classification level of a Chief Executive Officer in accordance with the following table:

Institution Annual Income (Less Capital) Ranges	Classification Level	Remuneration Ranges		
		Minimum	Mid-Point	Maximum
Greater than \$107.7 Million	CEO 1	\$238,478	\$267,317	\$296,155
Up to \$107.7 Million	CEO 2	\$196,754	\$217,615	\$238,477
	EO	\$141,667		

Dated 21 December 2012

THE HON. PETER HALL, MLC
Minister for Higher Education and Skills

Education and Training Reform Act 2006

MINISTERIAL ORDERS 2012

Order No. 632

The Minister for Higher Education and Skills and the Minister responsible for the Teaching Profession, under the powers contained in sections 5.2.1, 5.2.12, 5.10.4 and 5.10.5, and clause 8 of Schedule 6 of the **Education and Training Reform Act 2006**, makes the following Order.

1 The Teaching Service (Employment Conditions, Salaries, Allowances, Selection and Conduct) Order 2009 No. 199 is amended by:

(a) inserting the following after clause 2.8.1:

‘Division 9 – Deductions from salary

2.9.1 From 1 July 2009 and at all times after 1 July 2009, the following amounts are authorised to be deducted from and may lawfully be deducted from the salary of all persons employed in the Teaching Service under Part 2.4 of the Act:

- (a) any amount that a person employed in the Teaching Service has agreed will be deducted from the person’s salary in accordance with a Notebooks for Teachers and Principals Licence Agreement entered into by that person; and
- (b) any amount that a person employed in the Teaching Service has agreed will be deducted from the person’s salary in accordance with a Notebooks for Teachers and Principals Program Recipient Agreement entered into by that person; and
- (c) any amount that a person employed in the Teaching Service has agreed will be deducted from the person’s salary in accordance with an eduStar.NTP Recipient Agreement entered into by that person; and
- (d) any amount that a person employed in the Teaching Service has agreed will be deducted from that person’s salary in accordance with an agreement entered into by the person pursuant to any program that has succeeded or succeeds the eduStar.NTP Program for the provision of information and communications technology to persons employed in the Teaching Service; and
- (e) any amount that a person employed in the Teaching Service has agreed will be deducted from that person’s salary in accordance with any agreement entered into by that person in relation to the provision of information and communications technology to persons employed in the Teaching Service.’

This Order operates and takes effect from and inclusive of 1 July 2009.

Dated 19 December 2012

THE HON PETER HALL, MLC
Minister for Higher Education and Skills
Minister responsible for the Teaching Profession

Education and Training Reform Act 2006

NOTIFICATION CANCELLING REGISTRATION OF A TEACHER

Pursuant to section 2.6.29 of the **Education and Training Reform Act 2006**, the Victorian Institute of Teaching must disqualify a registered teacher from teaching and cancel his/her registration where that person has been convicted or found guilty at any time in Victoria or elsewhere of a sexual offence.

On 20 December 2012, Adrian Michael Fennessy was convicted of the sexual offence of:

a. one count of knowingly possessing child pornography

On 20 December 2012, Adrian Michael Fennessy was disqualified from teaching and his registration as a teacher in Victoria was cancelled.

Electoral Act 2002RE-REGISTRATION OF
POLITICAL PARTY

In accordance with section 58D of the **Electoral Act 2002**, the following party is hereby re-registered:

Socialist Alliance (Victoria)

Dated 21 December 2012

E. A. WILLIAMS
Victorian Electoral Commission

SCHEDULE 1

A Prohibited Period shall commence at 0100 hours on Monday 7 January 2013, and terminate at 0100 hours on 1 May 2013, unless varied, in the following municipality:

Baw Baw Shire

ALAN GOODWIN
Chief Fire Officer

Department of Sustainability and Environment
Delegated Officer, pursuant to section 11,
Conservation, Forests and Lands Act 1987

Electricity Industry Act 2000ERM POWER RETAIL PTY LIMITED
(ABN 87 126 175 460)Notice of Variation of
Electricity Retail Licence

The Essential Services Commission gives notice under section 30 of the **Electricity Industry Act 2000** (EI Act) that at its meeting of 5 December 2012, pursuant to section 29 of the EI Act, varied the licence of ERM Power Retail Pty Limited (ABN 87 126 175 460), reference ER03/2007, to a licence to retail electricity to business customers in Victoria.

A copy of the licence is available on the Commission's website located at <http://www.esc.vic.gov.au> or a copy can be obtained by contacting the Commission's reception on (03) 9032 1300.

DR RON BEN-DAVID
Chairperson

Forests Act 1958, No. 6254DECLARATION OF THE
PROHIBITED PERIOD

In pursuance of the powers conferred by section 3 sub-section (2) of the **Forests Act 1958**, I, Alan Goodwin, delegated officer for the Minister for Environment and Climate Change in the State of Victoria, hereby declare the commencement of the Prohibited Period for all land within the Fire Protected Area (other than State forest, National Park and protected public land) within the municipalities nominated for the period specified in Schedule 1 (below):



NATIONAL RULES BOOK

- Amendments** – approved by Harness Racing Australia (HRA) 8 October 2012
 – adopted by Harness Racing Victoria 20 December 2012
 – commencement date of amendments will be advised in February/March 2013 edition of Harness Racer

DICTIONARY

Add Definitions (HRA Approved 8 October 2012)

‘**Australian Racing Board**’ means the Australian Racing Board Limited constituted in accordance with AR208 Australian Rules of Racing.

‘**Registered training establishment**’ means a property approved by a Controlling Body to be used for the purposes of conducting harness racing activities.

Amend Definition – add sub-rule (iii) (HRA Approved 8 October 2012)

‘**Drug of Abuse**’ means:

- (iii) For the purposes of determining whether a substance is a drug of abuse, any declaration by the Australian Racing Board shall prevail over any document published by Standards Australia.

2. STEWARDS

Powers

- **Add new sub-rule 15(1)(af) (HRA approved 8 October 2012)**

15. (1) (af) to direct a driver to drive in a designated number of trials and to their satisfaction prior to driving in a race other than an official trial.

3. MEETING AND RACES

Appointed times

- **Repeal existing Rule 43(1), (2), (3) (HRA approved 8 October 2012)**
- **Add new Rule 43(1), (2) (HRA approved 8 October 2012)**

43. (1) A driver engaged to drive a horse in a race shall report his attendance at the racecourse to the Stewards or the person authorised by the Stewards no later than 30 minutes prior to the official start time of the race or at such other time as prescribed by the Controlling Body.

- (2) A driver who fails to comply with sub-rule (1) is guilty of an offence.

4. LICENCES

Grant of licences and other matters – Trainers Licence

- **Amend Rule 90A(2.7)(b) (HRA approved 8 October 2012)**

- 90A (2.7) (b) Grade B, is licensed to train a horse which the person owns or partly owns or which is owned by the person’s spouse, other domestic partner, parent, sibling or child, or any horse approved by the Controlling Body upon the written application of the person.

5. HORSES

- **Add new sub-heading**
- **Add new sub-rule 119C (HRA approved 8 October 2012)**

Location of Horse

- 119C.** (1) A trainer shall not, without having made written application and obtained the consent of the Stewards, stable any horse trained by him in any location other than the address notified on the current stable return of the horse.
- (2) A trainer who fails to comply with sub-rule (1) is guilty of an offence and in addition to any other penalty that may be imposed, the nomination of the horse concerned may not be accepted or if after acceptance, be rejected and the horse withdrawn from or disqualified from the race.

7. STARTING**Outside draw**

- **Amend Rule 134A(1) (HRA approved 8 October 2012)**

- 134A.** (1) Where a horse is required to requalify pursuant to sub rules (1) or (4) of Rule 134 the Stewards may issue a notice in terms of form R134-A and give it to the trainer or authorised agent.

Starter's orders

- **Amend Rule 135(5) (HRA approved 8 October 2012)**

- 135.** (5) A driver, trainer, or other person who fails to have his or her horse in the relevant place by the times mentioned in sub rule (1) or sub rule (2) or fails to drive to the correct barrier position on the blow of the starter's whistle or as otherwise signalled, is guilty of an offence.

8. REQUIRED RACING STANDARD**Race to win or for best position**

- **Add new sub-rules 149(4), (5), (6), (7) (HRA approved 8 October 2012)**

- 149.** (4) A trainer shall not give a direction or instruction to a driver of a horse trained by him if that direction or instruction is unreasonable or is likely to prevent the driver from giving the horse full opportunity to win or obtain the best possible placing in the field.
- (5) A trainer who fails to comply with sub-rule (4) is guilty of an offence.
- (6) If a driver receives a direction or instruction that infringes sub-rule (4) he shall prior to the race notify the Stewards.
- (7) A driver who fails to comply with sub-rule (6) is guilty of an offence.

9. DRIVERS**Offences – relating to matters at the start and during the race**

- **Add new sub-rule 163(4) (HRA approved 8 October 2012)**
- **Renumber existing sub-rules 163(4) to 163(5), 163(5) to 163(6) (HRA approved 8 October 2012)**

- 163.** (4) A driver shall trail the immediately preceding horse as close as is reasonably practicable in all of the circumstances.
- (5) A driver who, in the opinion of the Stewards, fails to comply with any provision of this rule is guilty of an offence.
- (6) For the purposes of sub rule (1) 'crossing' occurs when a driver changing the position of the driver's horse, compels another runner to shorten stride or the driver of that other horse to pull it out of its stride.

14. GENERAL OFFENCES**Alcohol and related matters**

- **Add new sub-rule 252A(b) (HRA approved 8 October 2012)**
- **Renumber existing sub-rule 252A(b) to 252A(c) (HRA approved 8 October 2012)**
 - (b) A urine sample provided by a person to whom those rules apply shall only be declared free of any banned substance if the sample contains a creatinine concentration of 200 mg/L or greater. In the event that the urine sample does not contain this concentration, the person shall be required to deliver a further urine sample or samples as directed by the Stewards.
 - (c) the following substances and/or their metabolites, artifacts and isomers are declared as banned substances when their presence is detected by a breath analysing instrument at a concentration in excess of the applicable threshold level:
alcohol at a concentration in excess of 0.02%

21. GENERAL MATTERS**Singular and plural form**

- **Add new sub-rule 313(3) (HRA approved 8 October 2012)**
 - (3) Words or expressions importing the masculine gender shall be deemed and taken to include the female gender unless the contrary is expressly provided for.

Summary of Amendments – (HRA approved 8 October 2012)**RULES AMENDED**

90A(2.7)(b), 134A(1), 135(5)

NEW RULES / SUB-RULES

15(1)(af), 43(1), (2), 119C, 149(4), (5), (6), (7), 163(4), 252A(b), 313(3)

RULES REPEALED

43(1), (2), (3)

RULES RENUMBERED

163(4), (5), 252A(c)

ADD DICTIONARY DEFINITIONS

‘Australian Racing Board’

‘Registered training establishment’

AMEND DICTIONARY DEFINITIONS‘Drug of Abuse’

Land Acquisition and Compensation Act 1986

FORM 7

S. 21(a)
Reg. 16

Notice of Acquisition

Compulsory Acquisition of Interest in Land

The Coliban Region Water Corporation (ABN 96 549 082 363), of 37–45 Bridge Street, Bendigo 3550, declares that by this notice it acquires the following interest in the land described as Crown Allotment 31 Section 6 Parish of Faraday, being more particularly contained within Certificate of Title Volume 9168 Folio 458:

An Easement for a Pipeline for Water Supply purposes over that part of the land shown as 'E-1' on the Plan of Creation of Easement (Ref 2004-P068), which is annexed hereto.

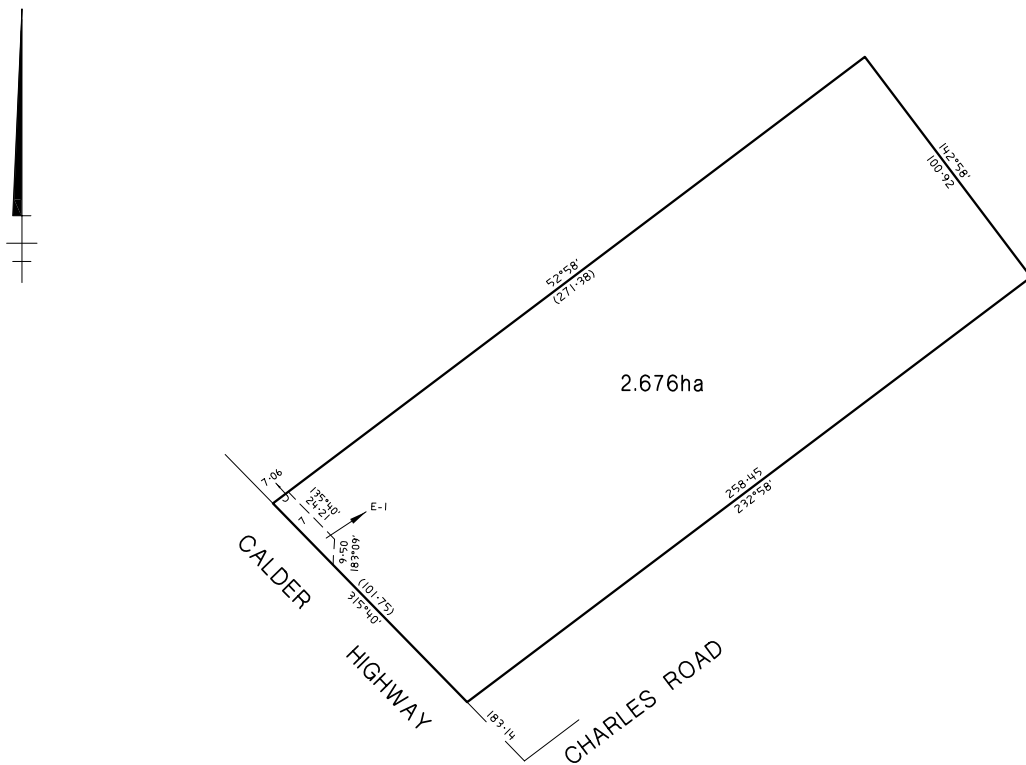

ORIGINAL		SCALE					
SCALE	SHEET SIZE	12.5	0	12.5	25	37.5	50
1:1250	A3	LENGTHS ARE IN METRES					

REF. 2004-P068

Published with the authority of the Coliban Region Water Corporation.

For and on behalf of the Coliban Region Water Corporation

Signed Andrew Cooney

Name ANDREW COONEY
Corporate Secretary

Dated 3 January 2013

Land Acquisition and Compensation Act 1986

FORM 7

S. 21(a)
Reg. 16

Notice of Acquisition

Compulsory Acquisition of Interest in Land

The Coliban Region Water Corporation (ABN 96 549 082 363), of 37–45 Bridge Street, Bendigo 3550, declares that by this notice it acquires the following interest in the land described as Crown Allotment 32 Section 6 Parish of Faraday, being more particularly contained within Certificate of Title Volume 9271 Folio 866:

An Easement for a Pipeline for Water Supply purposes over that part of the land shown as 'E-1' on the Plan of Creation of Easement (Ref 2004-P069), which is annexed hereto.

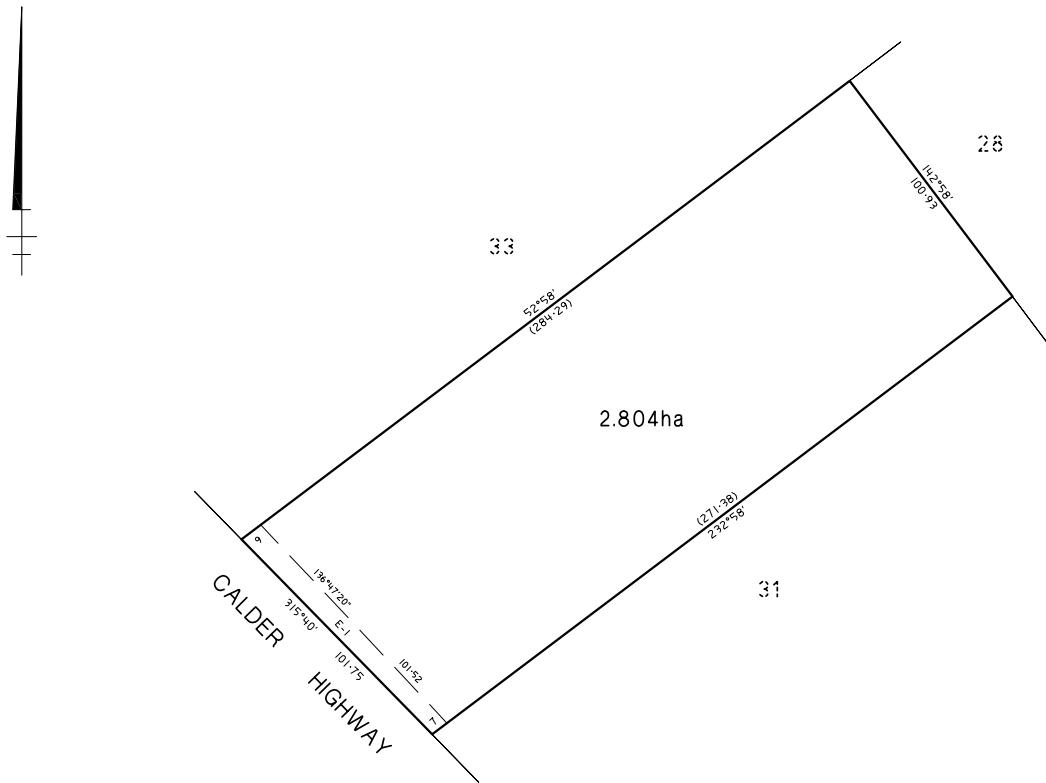

ORIGINAL		SCALE					
SCALE	SHEET SIZE	12.5	0	12.5	25	37.5	50
1:1250	A3	LENGTHS ARE IN METRES					REF. 2004-P069

Published with the authority of the Coliban Region Water Corporation.

For and on behalf of the Coliban Region Water Corporation

Signed Andrew Cooney

Name ANDREW COONEY
Corporate Secretary

Dated 3 January 2013

Land Acquisition and Compensation Act 1986

FORM 7

S. 21(a)
Reg. 16

Notice of Acquisition

Compulsory Acquisition of Interest in Land

The Coliban Region Water Corporation (ABN 96 549 082 363), of 37-45 Bridge Street, Bendigo 3550, declares that by this notice it acquires the following interest in the land described as Lots 3 and 4 on Plan of Subdivision 522846E, being more particularly contained within Certificate of Title Volume 10007 Folio 788:

An Easement for a Pipeline for Water Supply purposes over that part of the land shown as 'E-1' on the Plan of Creation of Easement (Ref 2004-P070), which is annexed hereto.

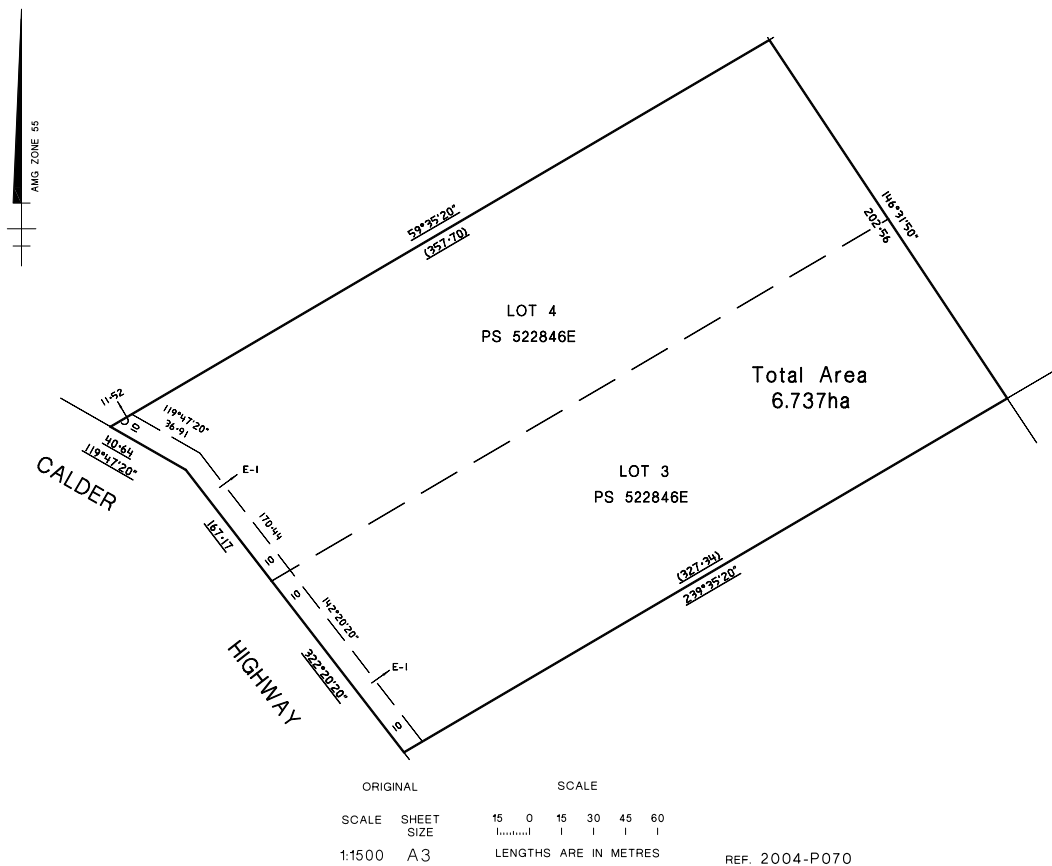

Published with the authority of the Coliban Region Water Corporation.

For and on behalf of the Coliban Region Water Corporation

Signed Andrew Cooney
Name ANDREW COONEY
Corporate Secretary

Dated 3 January 2013

Land Acquisition and Compensation Act 1986

FORM 7

S. 21(a)
Reg. 16

Notice of Acquisition

Compulsory Acquisition of Interest in Land

The Coliban Region Water Corporation (ABN 96 549 082 363), of 37-45 Bridge Street, Bendigo 3550, declares that by this notice it acquires the following interest in the land described as Lot 5 on Plan of Subdivision 522846E, being more particularly contained within Certificate of Title Volume 10816 Folio 071:

An Easement for a Pipeline for Water Supply purposes over that part of the land shown as 'E-1' on the Plan of Creation of Easement (Ref 2004-P072), which is annexed hereto.

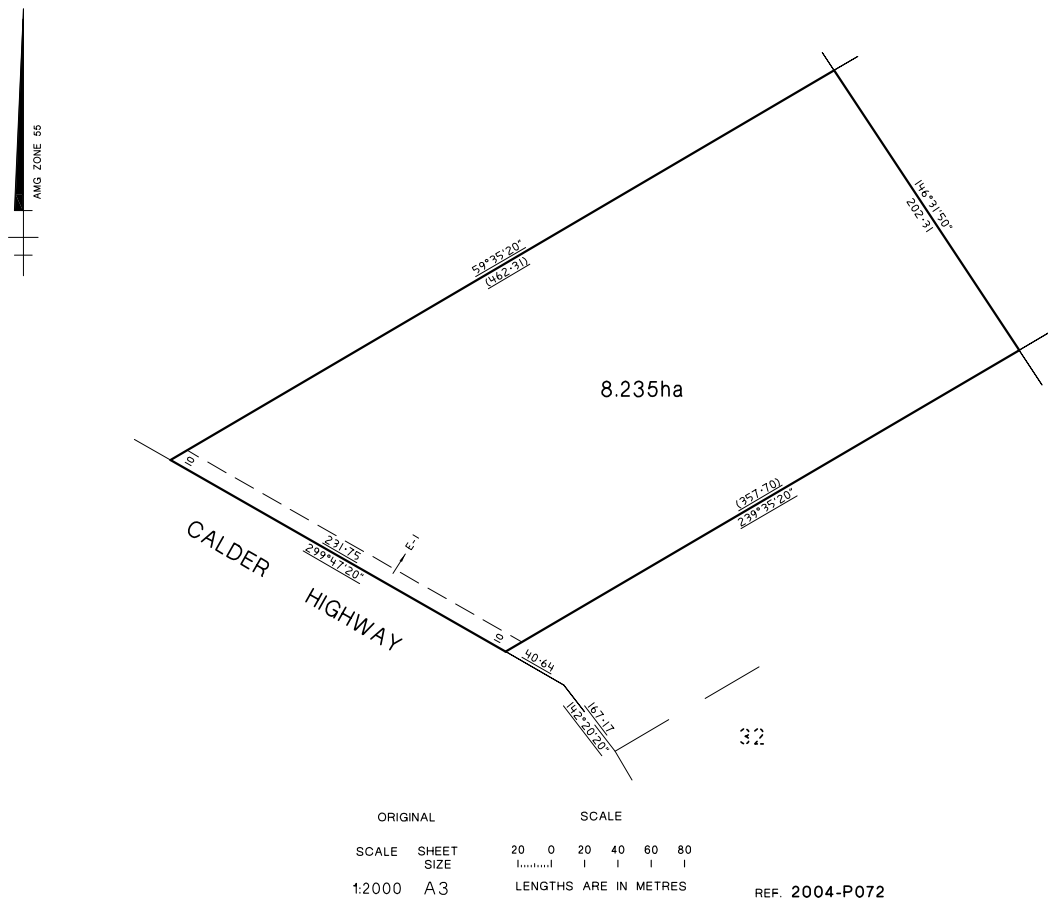

Published with the authority of the Coliban Region Water Corporation.

For and on behalf of the Coliban Region Water Corporation

Signed Andrew Cooney
Name ANDREW COONEY
Corporate Secretary
Dated 3 January 2013

Land Acquisition and Compensation Act 1986

FORM 7

S. 21(a)
Reg. 16

Notice of Acquisition

Compulsory Acquisition of Interest in Land

The Coliban Region Water Corporation (ABN 96 549 082 363), of 37–45 Bridge Street, Bendigo 3550, declares that by this notice it acquires the following interest in the land described as Lot 6 on Plan of Subdivision 522846E, being more particularly contained within Certificate of Title Volume 10839 Folio 659:

An Easement for a Pipeline for Water Supply purposes over that part of the land shown as ‘E-1’ on the Plan of Creation of Easement (Ref 2004-P073), which is annexed hereto.

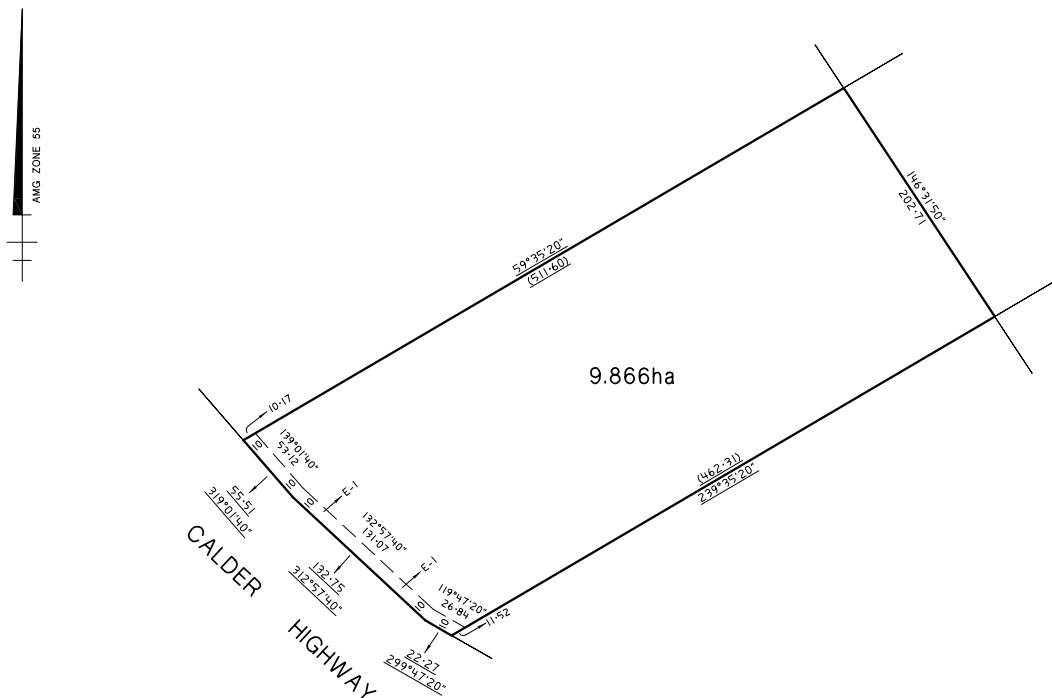

ORIGINAL	SCALE	
SCALE SHEET	25 0 25 50 75 100	
SIZE	
1:2500 A3	LENGTHS ARE IN METRES	REF. 2004-P073

Published with the authority of the Coliban Region Water Corporation.
 For and on behalf of the Coliban Region Water Corporation
 Signed Andrew Cooney
 Name ANDREW COONEY
 Corporate Secretary
 Dated 3 January 2013

Land Acquisition and Compensation Act 1986

FORM 7

S. 21(a)
Reg. 16

Notice of Acquisition

Compulsory Acquisition of Interest in Land

The Coliban Region Water Corporation (ABN 96 549 082 363), of 37–45 Bridge Street, Bendigo 3550, declares that by this notice it acquires the following interest in the land described as Lot 7 on Plan of Subdivision 522846E, being more particularly contained within Certificate of Title Volume 10816 Folio 068:

An Easement for a Pipeline for Water Supply purposes over that part of the land shown as 'E-1' on the Plan of Creation of Easement (Ref 2004-P074), which is annexed hereto.

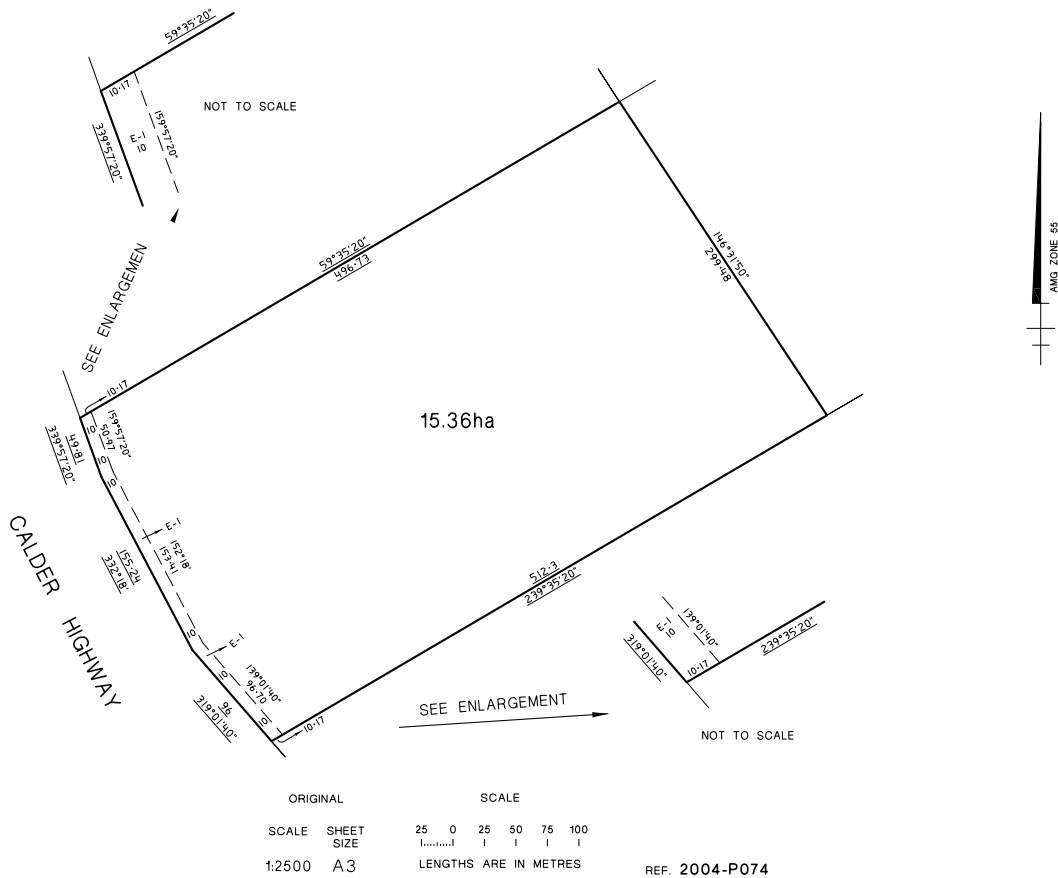

Published with the authority of the Coliban Region Water Corporation.

For and on behalf of the Coliban Region Water Corporation

Signed Andrew Cooney

Name ANDREW COONEY
Corporate Secretary

Dated 3 January 2013

Land Acquisition and Compensation Act 1986**FORM 7**S. 21(a)
Reg. 16

Notice of Acquisition

Compulsory Acquisition of Interest in Land

The Coliban Region Water Corporation (ABN 96 549 082 363), of 37–45 Bridge Street, Bendigo 3550, declares that by this notice it acquires the following interest in the land described as Land in Plan of Consolidation 352518H, being more particularly contained within Certificate of Title Volume 10957 Folio 603:

An Easement for a Pipeline for Water Supply purposes over that part of the land shown as 'E-1' on the Plan of Creation of Easement (Ref 2004-P090), which is annexed hereto.

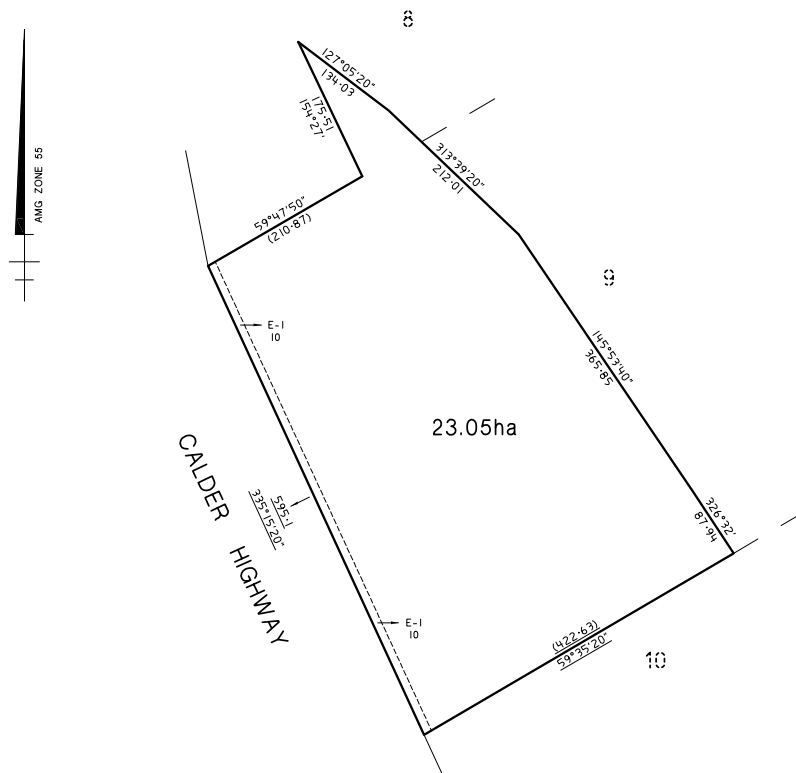

ORIGINAL SCALE
SCALE SHEET 40 0 40 80 120 160
SIZE A3 LENGTHS ARE IN METRES
1:4000 REF. 2004-P090

Published with the authority of the Coliban Region Water Corporation.

For and on behalf of the Coliban Region Water Corporation

Signed Andrew Cooney

Name ANDREW COONEY
Corporate Secretary

Dated 3 January 2013

Land Acquisition and Compensation Act 1986

FORM 7

S. 21(a)
Reg. 16

Notice of Acquisition

Compulsory Acquisition of Interest in Land

The Coliban Region Water Corporation (ABN 96 549 082 363), of 37–45 Bridge Street, Bendigo 3550, declares that by this notice it acquires the following interest in the land described as Lot 1 on Plan of Subdivision 518288M, being more particularly contained within Certificate of Title Volume 10954 Folio 059:

An Easement for a Pipeline for Water Supply purposes over that part of the land shown as 'E-1' on the Plan of Creation of Easement (Ref 2004-P091), which is annexed hereto.

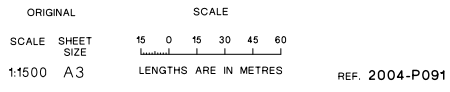
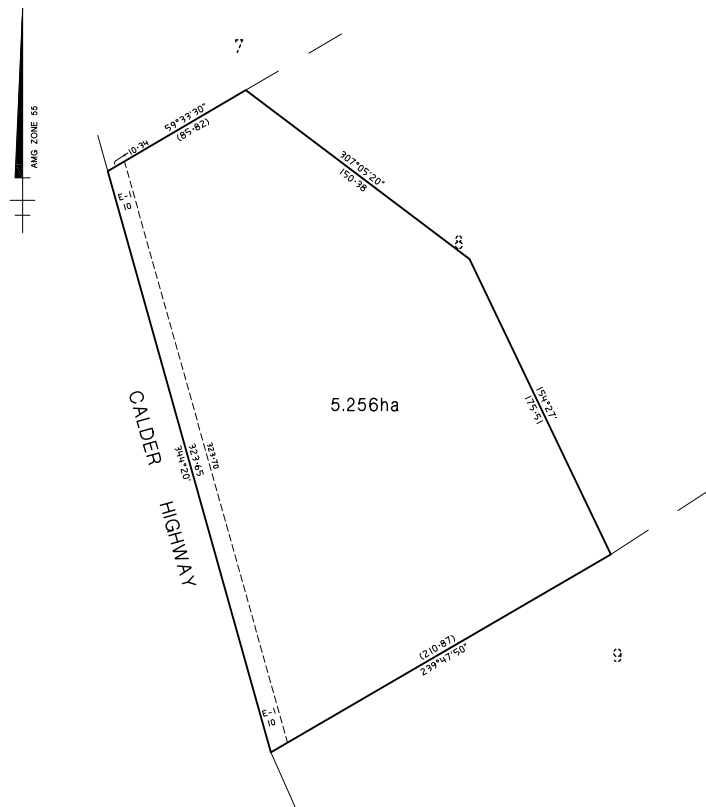

Published with the authority of the Coliban Region Water Corporation.
 For and on behalf of the Coliban Region Water Corporation
 Signed Andrew Cooney
 Name ANDREW COONEY
 Corporate Secretary
 Dated 3 January 2013

Land Acquisition and Compensation Act 1986

FORM 7

S. 21(a)
Reg. 16

Notice of Acquisition

Compulsory Acquisition of Interest in Land

The Coliban Region Water Corporation (ABN 96 549 082 363), of 37-45 Bridge Street, Bendigo 3550, declares that by this notice it acquires the following interest in the land described as Crown Allotments 1 and 2 Section 4 Parish of Faraday and Lot 1 on Title Plan 826474J, being more particularly contained within Certificates of Title Volume 10723 Folios 358, 359 and 361:

An Easement for a Pipeline for Water Supply purposes over that part of the land shown as 'E-1' on the Plans of Creation of Easement (Ref 2004-P102, 2004-P103 and 2004-P104), which are annexed hereto.

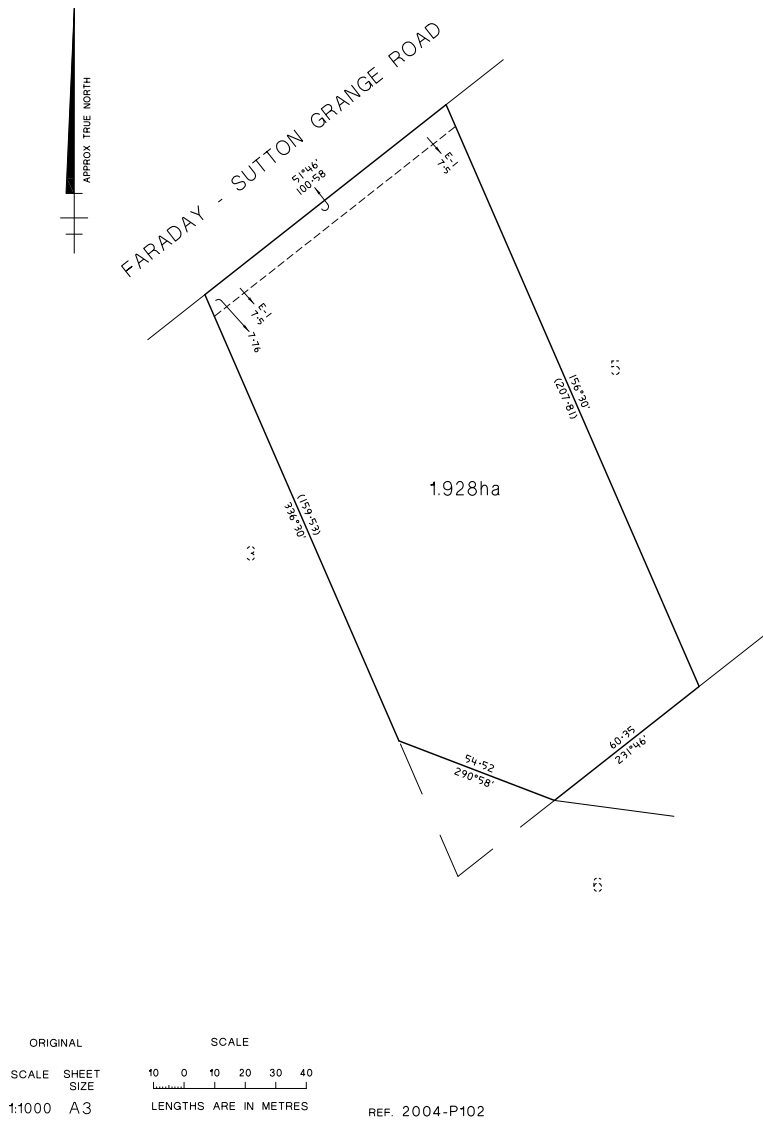

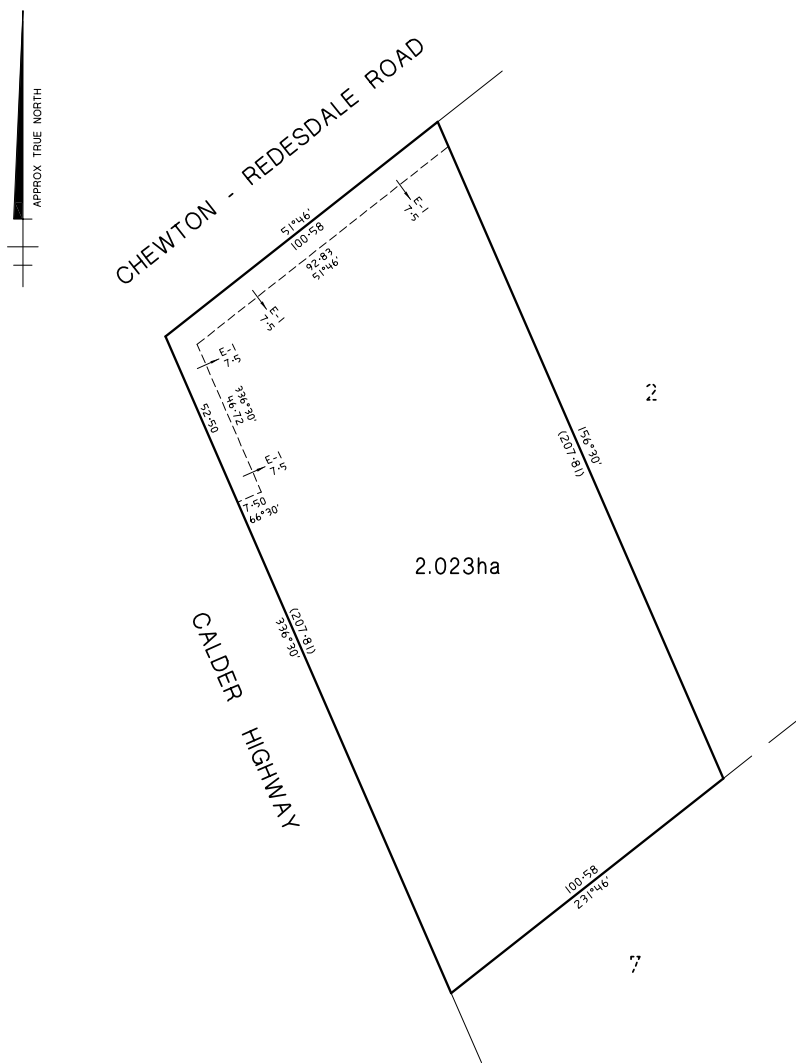

ORIGINAL
 SCALE SHEET SIZE
 1:1000 A3

SCALE
 10 0 10 20 30 40
 LENGTHS ARE IN METRES

REF. 2004-P103

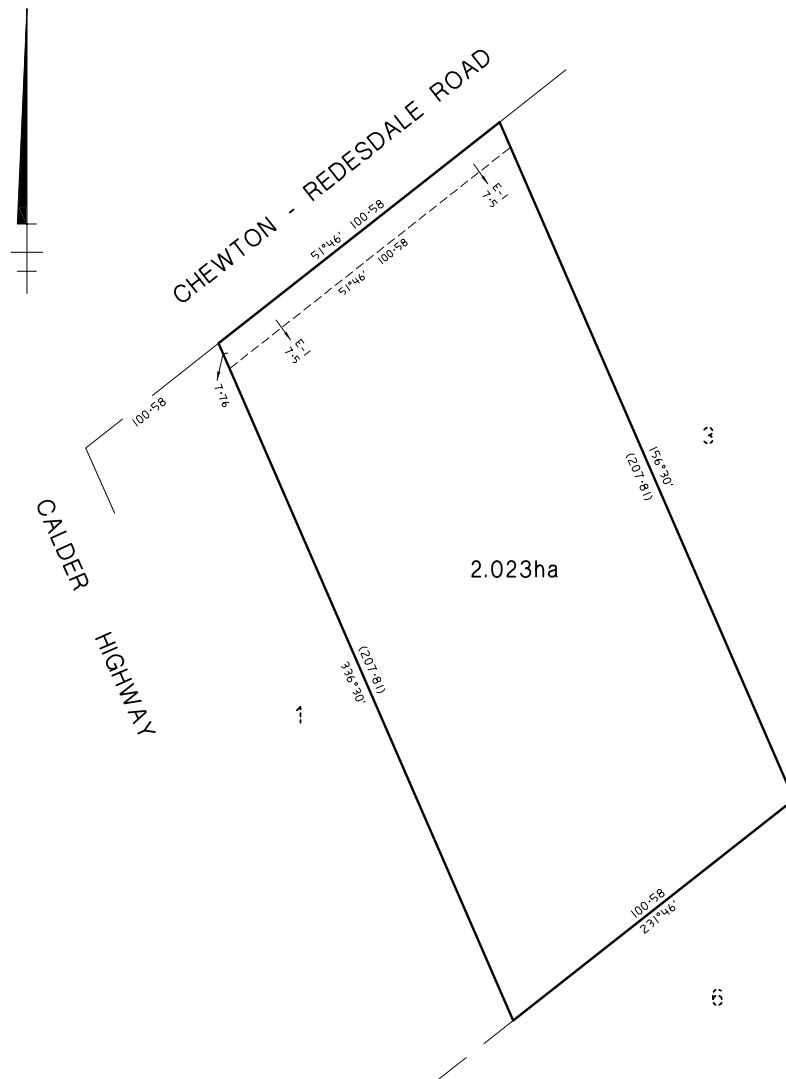

ORIGINAL SCALE
SCALE SHEET SIZE
1:1000 A3
10 0 10 20 30 40
LENGTHS ARE IN METRES

REF. 2004-P104

Published with the authority of the Coliban Region Water Corporation.
For and on behalf of the Coliban Region Water Corporation
Signed Andrew Cooney
Name ANDREW COONEY
Corporate Secretary
Dated 3 January 2013

Land Acquisition and Compensation Act 1986

FORM 7

S. 21(a)
Reg. 16

Notice of Acquisition

Compulsory Acquisition of Interest in Land

The Coliban Region Water Corporation (ABN 96 549 082 363), of 37-45 Bridge Street, Bendigo 3550, declares that by this notice it acquires the following interest in the land described as Lot 2 on Title Plan 8623G, being more particularly contained within Certificate of Title Volume 10330 Folio 885:

An Easement for a Pipeline for Water Supply purposes over that part of the land shown as 'E-1' on the Plan of Creation of Easement (Ref 2004-P130), which is annexed hereto.

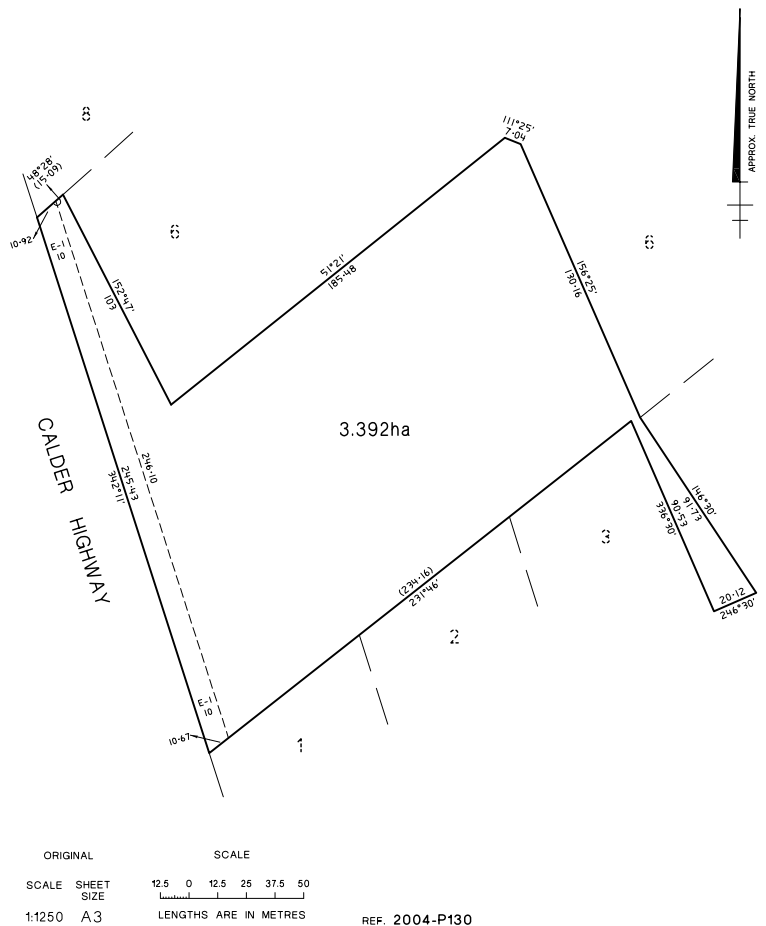

Published with the authority of the Coliban Region Water Corporation.

For and on behalf of the Coliban Region Water Corporation

Signed Andrew Cooney

Name ANDREW COONEY
Corporate Secretary

Dated 3 January 2013

Land Acquisition and Compensation Act 1986**FORM 7**S. 21(a)
Reg. 16

Notice of Acquisition

Compulsory Acquisition of Interest in Land

The Coliban Region Water Corporation (ABN 96 549 082 363), of 37–45 Bridge Street, Bendigo 3550, declares that by this notice it acquires the following interest in the land described as Lot 4 on Title Plan 8623G, being more particularly contained within Certificate of Title Volume 11259 Folio 716:

An Easement for a Pipeline for Water Supply purposes over that part of the land shown as 'E-1' on the Plan of Creation of Easement (Ref 2004-P139), which is annexed hereto.

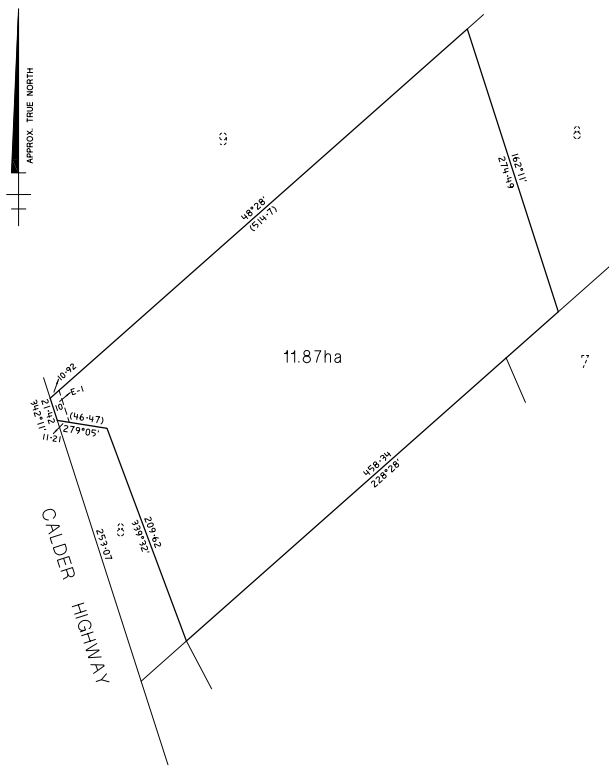

ORIGINAL SCALE
SCALE SHEET SIZE 1:2500 A3
LENGTHS ARE IN METRES
REF. 2004-P139

Published with the authority of the Coliban Region Water Corporation.

For and on behalf of the Coliban Region Water Corporation

Signed Andrew Cooney
Name ANDREW COONEY
Corporate Secretary

Dated 3 January 2013

Land Acquisition and Compensation Act 1986

FORM 7

S. 21(a)
Reg. 16

Notice of Acquisition

Compulsory Acquisition of Interest in Land

The Coliban Region Water Corporation (ABN 96 549 082 363), of 37–45 Bridge Street, Bendigo 3550, declares that by this notice it acquires the following interest in the land described as Lot 5 on Title Plan 6612X, being more particularly contained within Certificate of Title Volume 10303 Folio 523:

An Easement for a Pipeline for Water Supply purposes over that part of the land shown as 'E-1' on the Plan of Creation of Easement (Ref 2004-P141), which is annexed hereto.

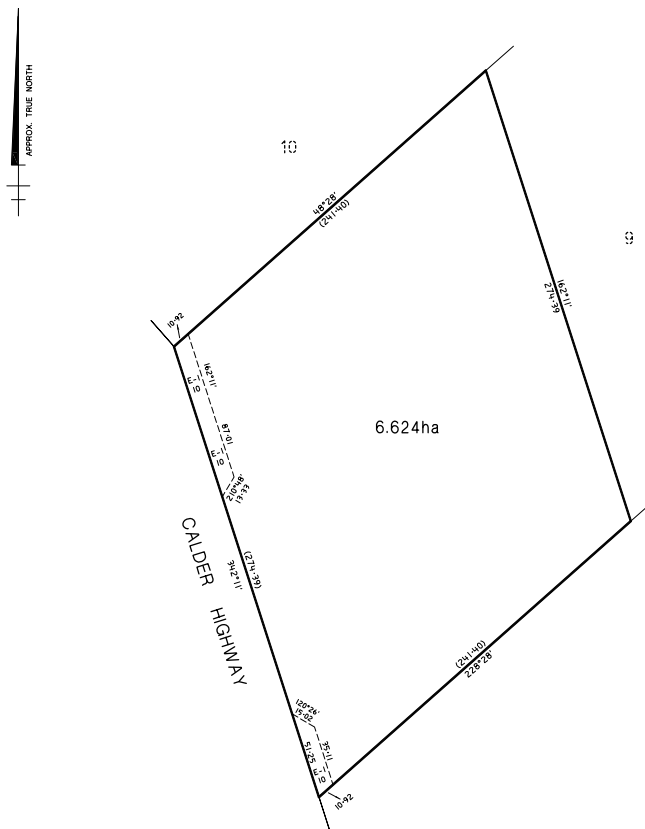

ORIGINAL SCALE
SCALE SHEET SIZE 1:1500 A3
LENGTHS ARE IN METRES REF. 2004-P141

Published with the authority of the Coliban Region Water Corporation.

For and on behalf of the Coliban Region Water Corporation

Signed Andrew Cooney
Name ANDREW COONEY
Corporate Secretary

Dated 3 January 2013

Land Acquisition and Compensation Act 1986

FORM 7

S. 21(a)
Reg. 16

Notice of Acquisition

Compulsory Acquisition of Interest in Land

The Coliban Region Water Corporation (ABN 96 549 082 363), of 37–45 Bridge Street, Bendigo 3550, declares that by this notice it acquires the following interest in the land described as Crown Allotment 5 Section 3A Parish of Faraday, being more particularly contained within Certificate of Title Volume 9300 Folio 999:

An Easement for a Pipeline for Water Supply purposes over that part of the land shown as ‘E-1’ on the Plan of Creation of Easement (Ref 2004-P171), which is annexed hereto.

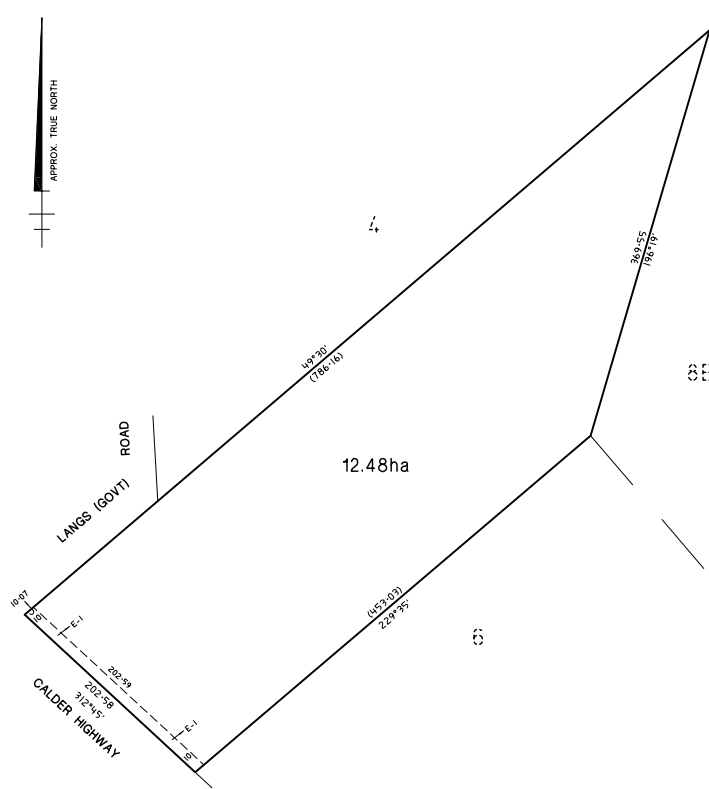

ORIGINAL SCALE
SCALE SHEET SIZE 1:2500 A3
25 0 25 50 75 100
LENGTHS ARE IN METRES
REF. 2004-P171

Published with the authority of the Coliban Region Water Corporation.
For and on behalf of the Coliban Region Water Corporation
Signed Andrew Cooney
Name ANDREW COONEY
Corporate Secretary
Dated 3 January 2013

Land Acquisition and Compensation Act 1986

FORM 7

S. 21(a)
Reg. 16

Notice of Acquisition

Compulsory Acquisition of Interest in Land

The Coliban Region Water Corporation (ABN 96 549 082 363), of 37-45 Bridge Street, Bendigo 3550, declares that by this notice it acquires the following interest in the land described as Lot 1 on Title Plan 857644K, being more particularly contained within Certificate of Title Volume 10878 Folio 755:

An Easement for a Pipeline for Water Supply purposes over that part of the land shown as 'E-1' on the Plan of Creation of Easement (Ref 2004-P172), which is annexed hereto.

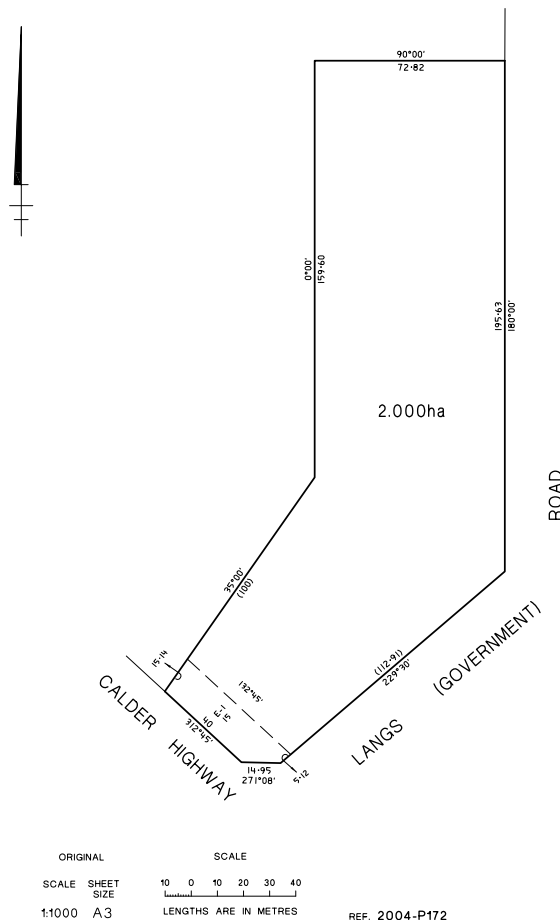

Published with the authority of the Coliban Region Water Corporation.

For and on behalf of the Coliban Region Water Corporation

Signed Andrew Cooney

Name ANDREW COONEY
Corporate Secretary

Dated 3 January 2013

Land Acquisition and Compensation Act 1986

FORM 7

S. 21(a)
Reg. 16

Notice of Acquisition

Compulsory Acquisition of Interest in Land

The Coliban Region Water Corporation (ABN 96 549 082 363), of 37-45 Bridge Street, Bendigo 3550, declares that by this notice it acquires the following interest in the land described as Lot 1 on Title Plan 803352D, being more particularly contained within Certificate of Title Volume 10643 Folio 508:

An Easement for a Pipeline for Water Supply purposes over that part of the land shown as 'E-1' on the Plan of Creation of Easement (Ref 2004-P176), which is annexed hereto.

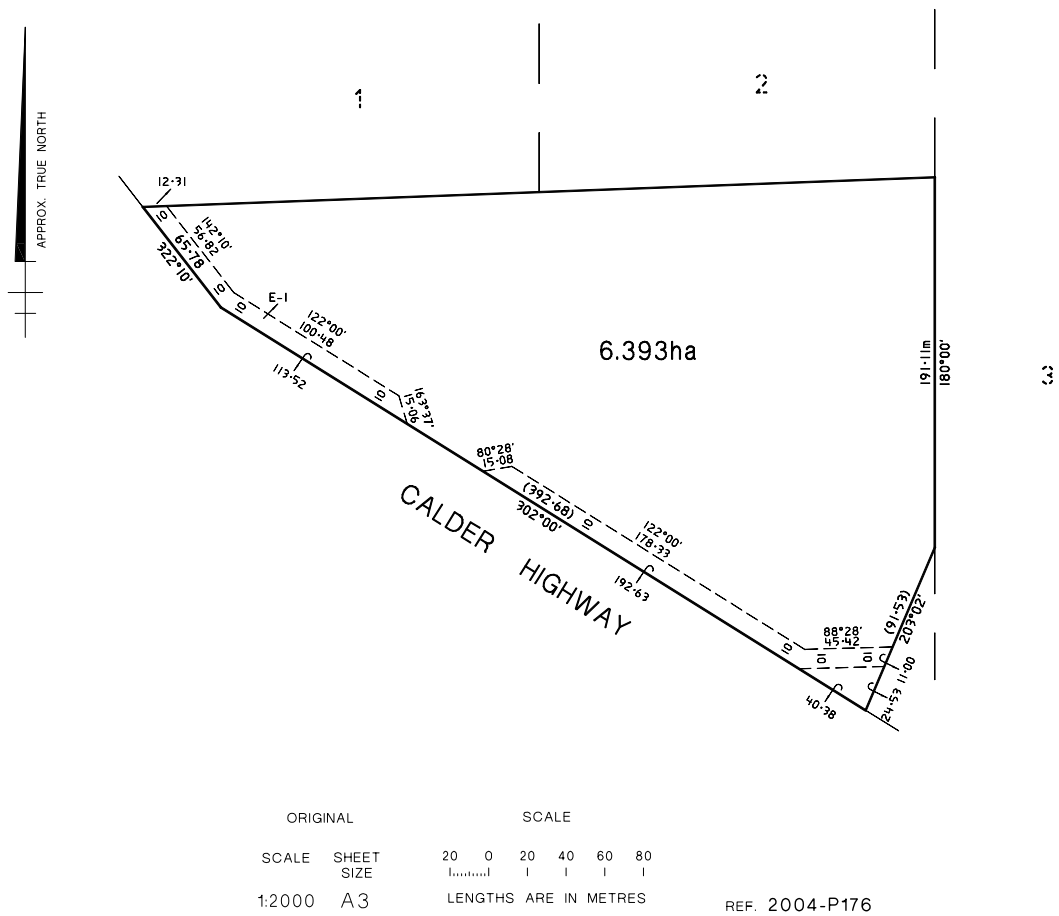

Published with the authority of the Coliban Region Water Corporation.

For and on behalf of the Coliban Region Water Corporation

Signed Andrew Cooney
Name ANDREW COONEY
Corporate Secretary

Dated 3 January 2013

Land Acquisition and Compensation Act 1986

FORM 7

S. 21(a)
Reg. 16

Notice of Acquisition

Compulsory Acquisition of Interest in Land

The Coliban Region Water Corporation (ABN 96 549 082 363), of 37-45 Bridge Street, Bendigo 3550, declares that by this notice it acquires the following interest in the land described as Lot 2 on Plan of Subdivision 417214G, being more particularly contained within Certificate of Title Volume 10384 Folio 887:

An Easement for a Pipeline for Water Supply purposes over that part of the land shown as 'E-1' on the Plan of Creation of Easement (Ref 2004-P194), which is annexed hereto.

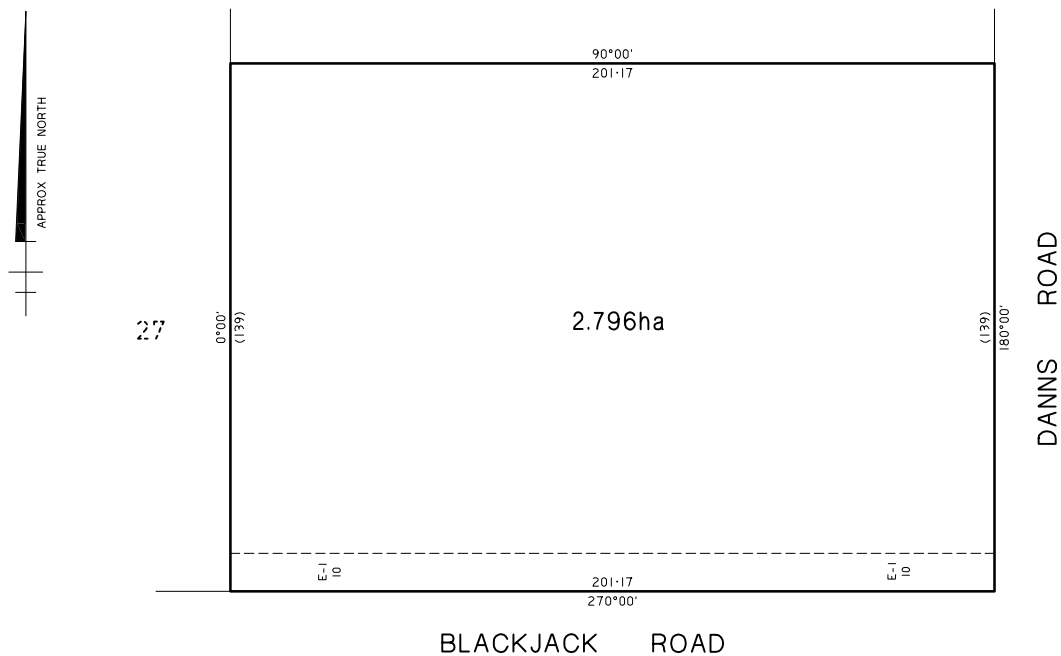

ORIGINAL		SCALE	
SCALE	SHEET SIZE	10 0 10 20 30 40	
1:1000	A3	
LENGTHS ARE IN METRES			REF. 2004-P194

Published with the authority of the Coliban Region Water Corporation.

For and on behalf of the Coliban Region Water Corporation

Signed Andrew Cooney

Name ANDREW COONEY
Corporate Secretary

Dated 3 January 2013

Land Acquisition and Compensation Act 1986

FORM 7

S. 21(a)
Reg. 16

Notice of Acquisition

Compulsory Acquisition of Interest in Land

The Coliban Region Water Corporation (ABN 96 549 082 363), of 37–45 Bridge Street, Bendigo 3550, declares that by this notice it acquires the following interest in the land described as Crown Allotment 3 Section 3 Parish of Harcourt, being more particularly contained within Certificate of Title Volume 9827 Folio 786:

An Easement for a Pipeline for Water Supply purposes over that part of the land shown as ‘E-1’ on the Plan of Creation of Easement (Ref 2004-P219), which is annexed hereto.

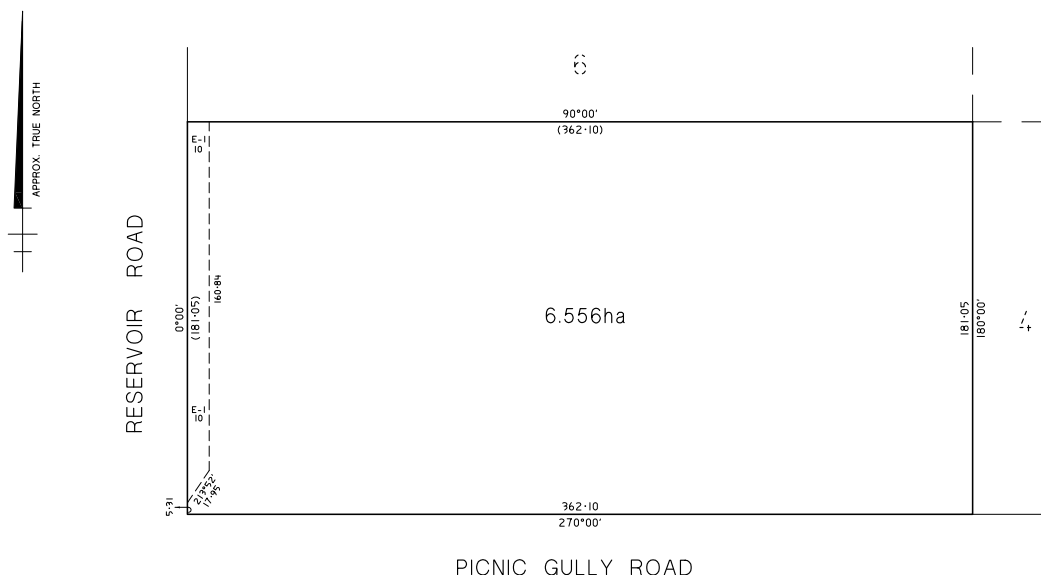

ORIGINAL		SCALE					
SCALE	SHEET SIZE	15	0	15	30	45	60
1:1500	A3	LENGTHS ARE IN METRES				REF. 2004-P219	

Published with the authority of the Coliban Region Water Corporation.
 For and on behalf of the Coliban Region Water Corporation
 Signed Andrew Cooney
 Name ANDREW COONEY
 Corporate Secretary
 Dated 3 January 2013

Land Acquisition and Compensation Act 1986
FORM 7

S. 21(a)
 Reg. 16

Notice of Acquisition
Compulsory Acquisition of Interest in Land

The Coliban Region Water Corporation (ABN 96 549 082 363), of 37–45 Bridge Street, Bendigo 3550, declares that by this notice it acquires the following interest in the land described as Crown Allotment 6 Section 3 Parish of Harcourt, being more particularly contained within Conveyance No. 66 Book 826:

An Easement for a Pipeline for Water Supply purposes over that part of the land shown as 'E-1' on the Plan of Creation of Easement (Ref 2004-P220), which is annexed hereto.

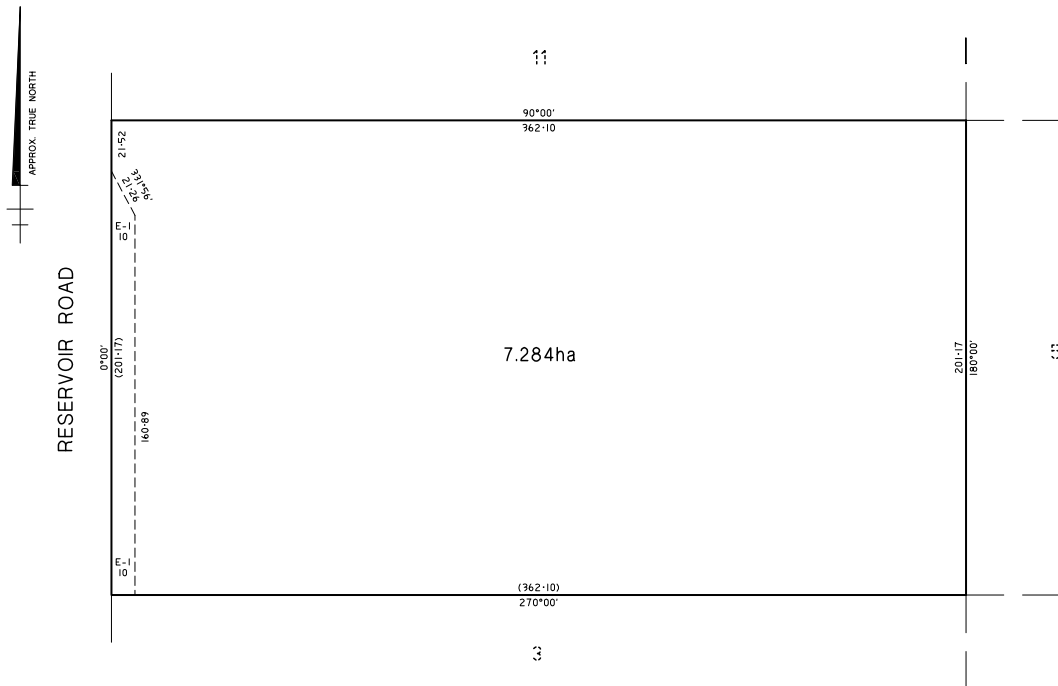

ORIGINAL		SCALE	
SCALE	SHEET SIZE	12.5	0 12.5 25 37.5 50
1:1250	A3	LENGTHS ARE IN METRES	
		REF. 2004-P220	

Published with the authority of the Coliban Region Water Corporation.
 For and on behalf of the Coliban Region Water Corporation
 Signed Andrew Cooney
 Name ANDREW COONEY
 Corporate Secretary
 Dated 3 January 2013

Land Acquisition and Compensation Act 1986

FORM 7

S. 21(a)
Reg. 16

Notice of Acquisition

Compulsory Acquisition of Interest in Land

The Coliban Region Water Corporation (ABN 96 549 082 363), of 37–45 Bridge Street, Bendigo 3550, declares that by this notice it acquires the following interest in the land described as Crown Allotment 10 Section 3 Parish of Harcourt, being more particularly contained within Conveyance No. 573 Book 664 and No. 651 Book 666:

An Easement for a Pipeline for Water Supply purposes over that part of the land shown as ‘E-1’ on the Plan of Creation of Easement (Ref 2004-P226), which is annexed hereto.

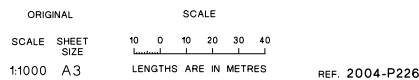
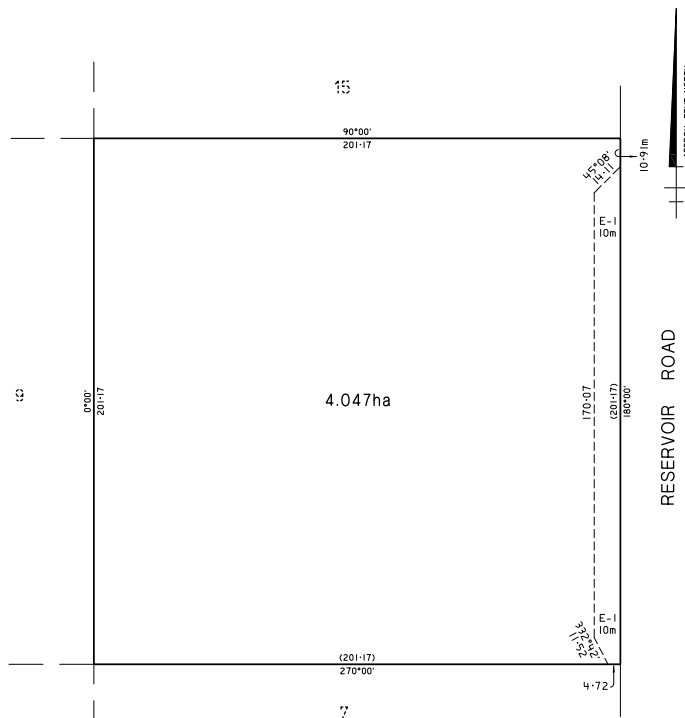

Published with the authority of the Coliban Region Water Corporation.
 For and on behalf of the Coliban Region Water Corporation
 Signed Andrew Cooney
 Name ANDREW COONEY
 Corporate Secretary
 Dated 3 January 2013

Land Acquisition and Compensation Act 1986

FORM 7

S. 21(a)
Reg. 16

Notice of Acquisition

Compulsory Acquisition of Interest in Land

The Coliban Region Water Corporation (ABN 96 549 082 363), of 37–45 Bridge Street, Bendigo 3550, declares that by this notice it acquires the following interest in the land described as Crown Allotment 15 Section 3 Parish of Harcourt, being more particularly contained within Certificate of Title Volume 10741 Folio 113:

An Easement for a Pipeline for Water Supply purposes over that part of the land shown as 'E-1' on the Plan of Creation of Easement (Ref 2004-P227), which is annexed hereto.

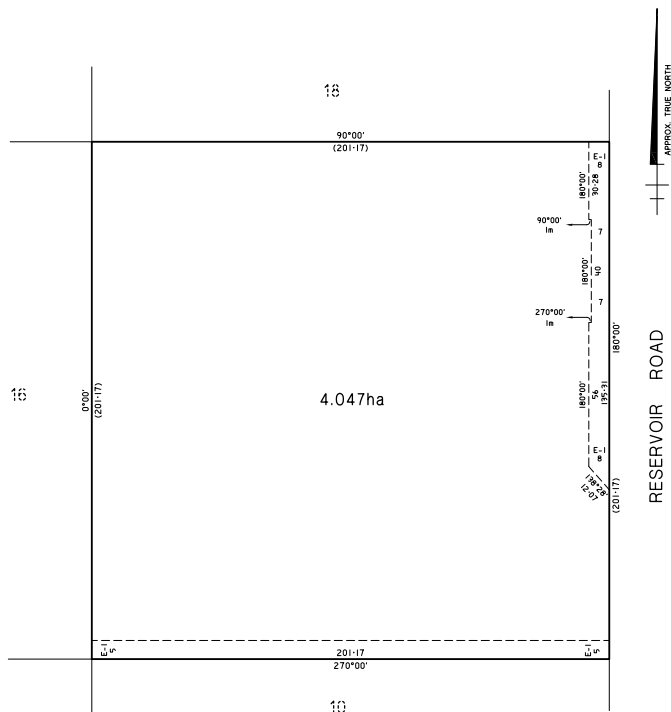

ORIGINAL SCALE
SCALE SHEET SIZE 1:1000 A3
LENGTHS ARE IN METRES
REF. 2004-P227

Published with the authority of the Coliban Region Water Corporation.

For and on behalf of the Coliban Region Water Corporation

Signed Andrew Cooney

Name ANDREW COONEY
Corporate Secretary

Dated 3 January 2013

Land Acquisition and Compensation Act 1986

FORM 7

S. 21(a)
Reg. 16

Notice of Acquisition

Compulsory Acquisition of Interest in Land

The Coliban Region Water Corporation (ABN 96 549 082 363), of 37-45 Bridge Street, Bendigo 3550, declares that by this notice it acquires the following interest in the land described as Lot 1 on Plan of Subdivision 116605, being more particularly contained within Certificate of Title Volume 9136 Folio 139:

An Easement for a Pipeline for Water Supply purposes over that part of the land shown as 'E-2' on the Plan of Creation of Easement (Ref 2004-P233), which is annexed hereto.

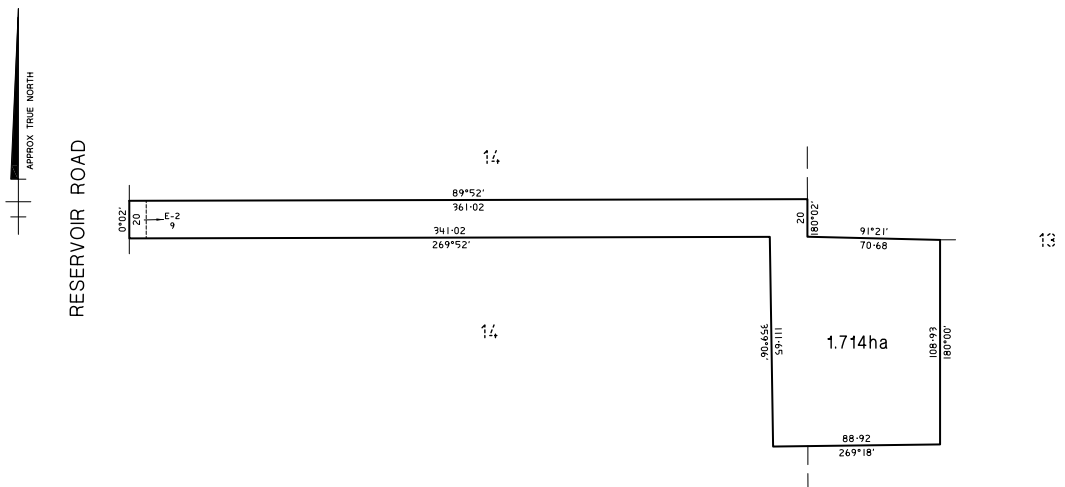

ORIGINAL SCALE
SCALE SHEET 15 0 15 30 45 60
SIZE A3 LENGTHS ARE IN METRES
1:1500 REF. 2004-P233

Published with the authority of the Coliban Region Water Corporation.

For and on behalf of the Coliban Region Water Corporation

Signed Andrew Cooney

Name ANDREW COONEY

Corporate Secretary

Dated 3 January 2013

Land Acquisition and Compensation Act 1986

FORM 7

S. 21(a)
Reg. 16

Notice of Acquisition

Compulsory Acquisition of Interest in Land

The Coliban Region Water Corporation (ABN 96 549 082 363), of 37–45 Bridge Street, Bendigo 3550, declares that by this notice it acquires the following interest in the land described as Lot 2 on Plan of Subdivision 116605, Lot 1 on Title Plan 671164K and Crown Allotment 25 Section 3 Parish of Harcourt, being more particularly contained within Certificates of Title Volume 9136 Folio 140, Volume 5651 Folio 009 and Volume 10254 Folio 015:

An Easement for a Pipeline for Water Supply purposes over that part of the land shown as ‘E-2’ on the Plans of Creation of Easement (Ref 2004-P235 and 2004-P237) and ‘E-3’ on the Plan of Creation of Easement (Ref 2004-P234), which are annexed hereto.

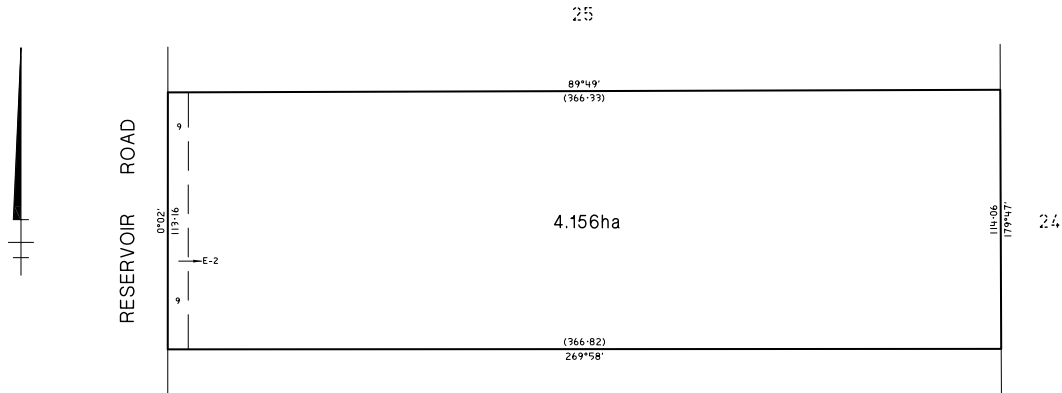

ORIGINAL		SCALE					
SCALE	SHEET SIZE	12.5	0	12.5	25	37.5	50
1:1250	A3	LENGTHS ARE IN METRES					
							REF. 2004-P235

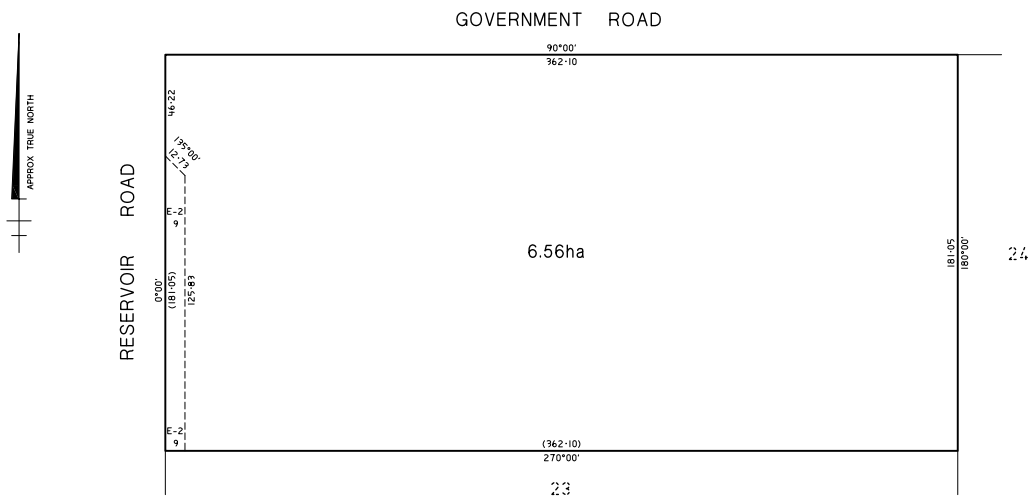

ORIGINAL SCALE
 SCALE SHEET 12.5 0 12.5 25 37.5 50
 SIZE A3
 LENGTHS ARE IN METRES
 REF. 2004-P237

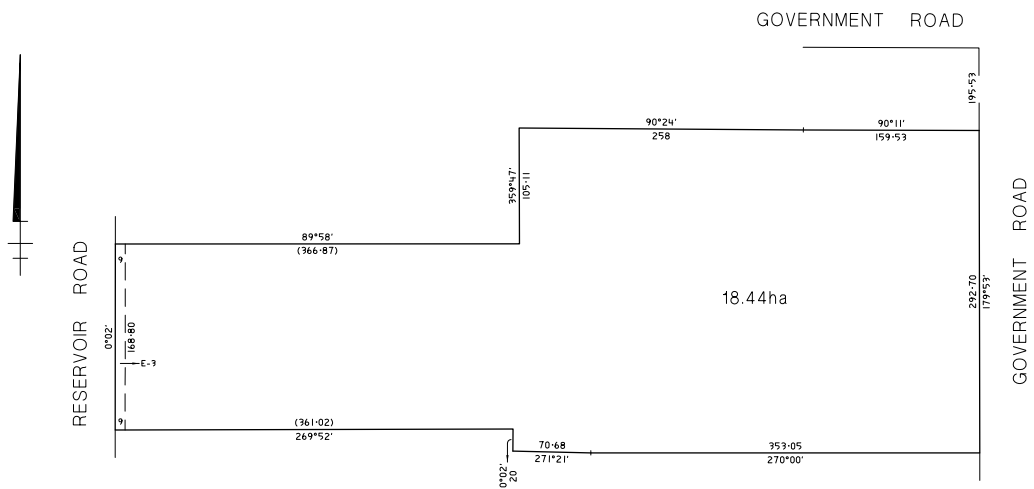

ORIGINAL SCALE
 SCALE SHEET 25 0 25 50 75 100
 SIZE A3
 LENGTHS ARE IN METRES
 REF. 2004-P234

Published with the authority of the Coliban Region Water Corporation.
 For and on behalf of the Coliban Region Water Corporation
 Signed Andrew Cooney
 Name ANDREW COONEY
 Corporate Secretary
 Dated 3 January 2013

Land Acquisition and Compensation Act 1986

FORM 7

S. 21(a)
Reg. 16

Notice of Acquisition

Compulsory Acquisition of Interest in Land

The Coliban Region Water Corporation (ABN 96 549 082 363), of 37–45 Bridge Street, Bendigo 3550, declares that by this notice it acquires the following interest in the land described as Crown Allotment 13 Section 2 Parish of Harcourt, being more particularly contained within Certificate of Title Volume 10282 Folio 606:

An Easement for a Pipeline for Water Supply purposes over that part of the land shown as 'E-1' on the Plan of Creation of Easement (Ref 2004-P244), which is annexed hereto.

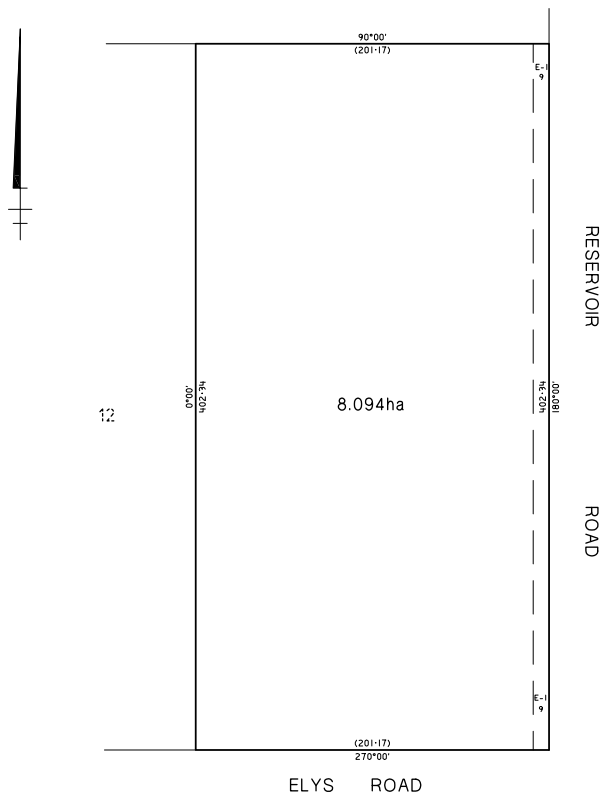

ORIGINAL SCALE
SCALE SHEET 15 0 15 30 45 60
SIZE A3
1:1500 LENGTHS ARE IN METRES REF. 2004-P244

Published with the authority of the Coliban Region Water Corporation.

For and on behalf of the Coliban Region Water Corporation

Signed Andrew Cooney

Name ANDREW COONEY
Corporate Secretary

Dated 3 January 2013

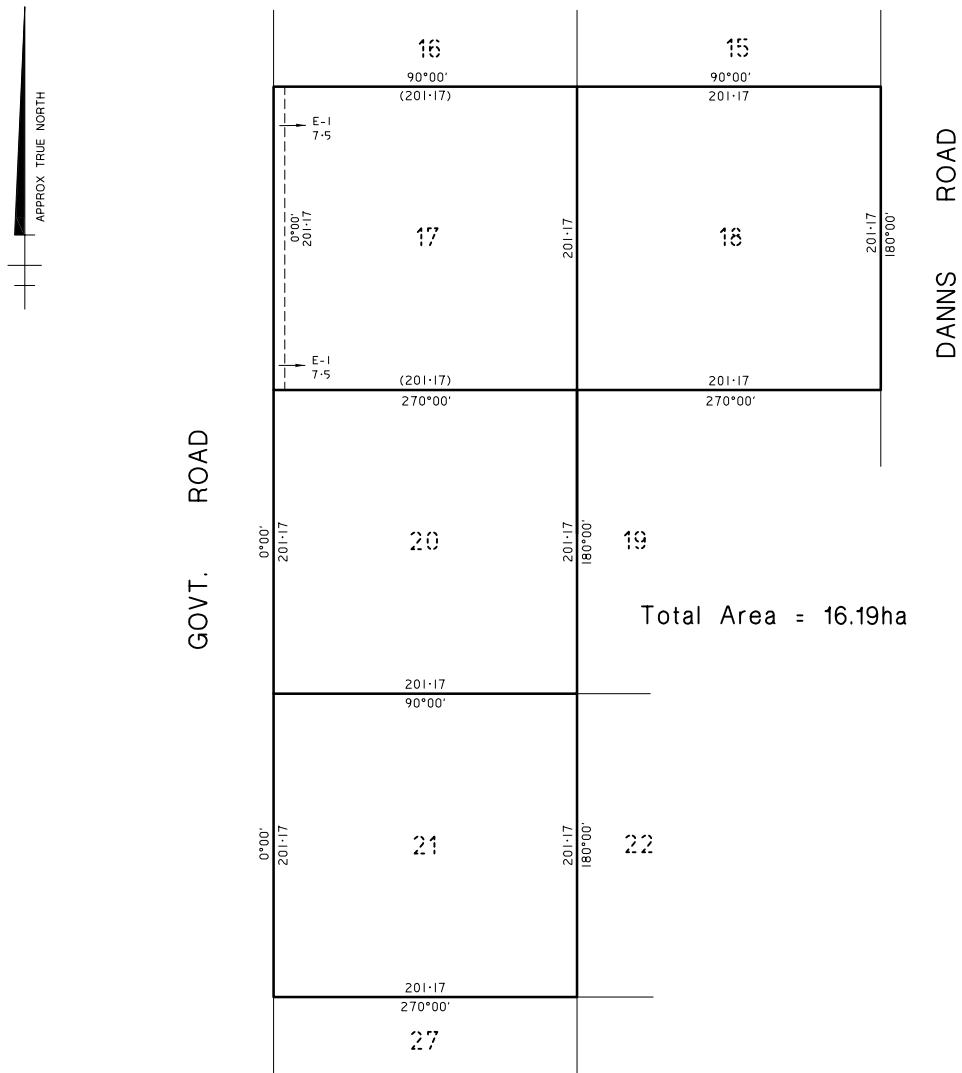

ORIGINAL SCALE

SCALE SHEET SIZE 25 0 25 50 75 100

1:2500 A3 LENGTHS ARE IN METRES

REF. 2004-R204

Published with the authority of the Coliban Region Water Corporation.
 For and on behalf of the Coliban Region Water Corporation
 Signed Andrew Cooney
 Name ANDREW COONEY
 Corporate Secretary
 Dated 3 January 2013

Land Acquisition and Compensation Act 1986

FORM 7

S. 21(a)
Reg. 16

Notice of Acquisition

Compulsory Acquisition of Interest in Land

The Coliban Region Water Corporation (ABN 96 549 082 363), of 37–45 Bridge Street, Bendigo 3550, declares that by this notice it acquires the following interest in the land described as Lot 2 on Plan of Subdivision 417581C, being more particularly contained within Certificate of Title Volume 10554 Folio 560:

An Easement for a Pipeline for Water Supply purposes over that part of the land shown as ‘E-3’ on the Plan of Creation of Easement (Ref 2004-P251), which is annexed hereto.

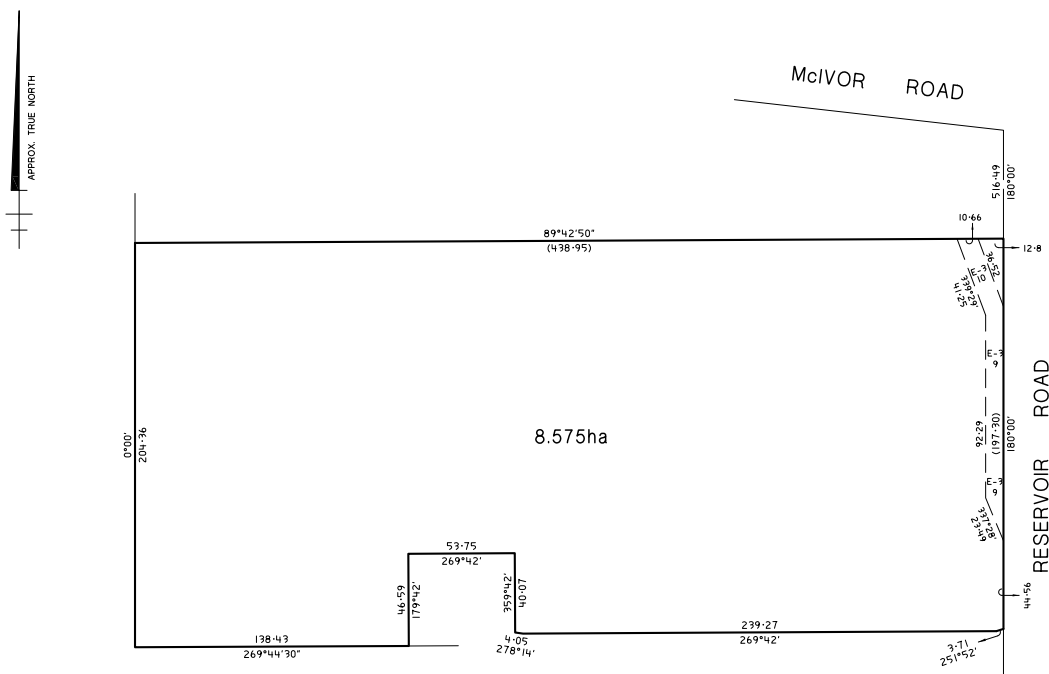

ORIGINAL	SCALE	
SCALE SHEET SIZE	15 0 15 30 45 60	
1:1500 A3	metres	LENGTHS ARE IN METRES
		REF. 2004-P251

Published with the authority of the Coliban Region Water Corporation.
 For and on behalf of the Coliban Region Water Corporation
 Signed Andrew Cooney
 Name ANDREW COONEY
 Corporate Secretary
 Dated 3 January 2013

Land Acquisition and Compensation Act 1986
FORM 7

S. 21(a)
 Reg. 16

Notice of Acquisition
Compulsory Acquisition of Interest in Land

The Coliban Region Water Corporation (ABN 96 549 082 363), of 37–45 Bridge Street, Bendigo 3550, declares that by this notice it acquires the following interest in the land described as Lot 1 on Plan of Subdivision 417581C, being more particularly contained within Certificate of Title Volume 10554 Folio 559:

An Easement for a Pipeline for Water Supply purposes over that part of the land shown as 'E-3' on the Plan of Creation of Easement (Ref 2004-P253), which is annexed hereto.

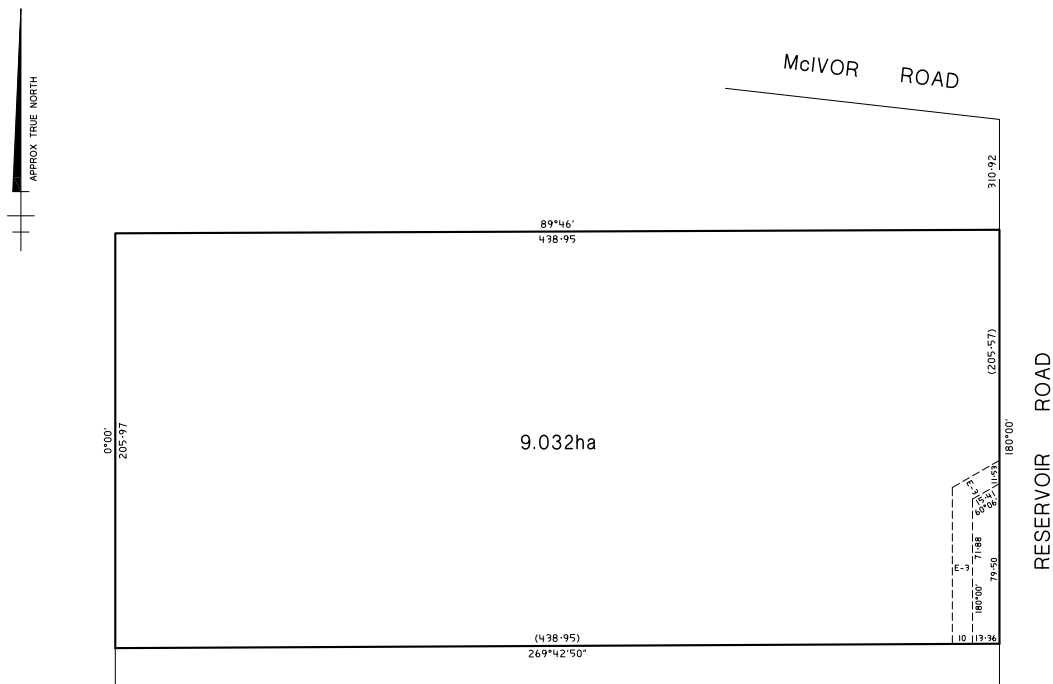

ORIGINAL		SCALE					
SCALE	SHEET SIZE	15	0	15	30	45	60
1:1500	A3	LENGTHS ARE IN METRES					
							REF. 2004-P253

Published with the authority of the Coliban Region Water Corporation.
 For and on behalf of the Coliban Region Water Corporation
 Signed Andrew Cooney
 Name ANDREW COONEY
 Corporate Secretary
 Dated 3 January 2013

Land Acquisition and Compensation Act 1986

FORM 7

S. 21(a)
Reg. 16

Notice of Acquisition

Compulsory Acquisition of Interest in Land

The Coliban Region Water Corporation (ABN 96 549 082 363), of 37-45 Bridge Street, Bendigo 3550, declares that by this notice it acquires the following interest in the land described as Lots 1 and 2 on Plan of Subdivision 502510D, being more particularly contained within Certificates of Title Volume 10746 Folios 881 and 882:

An Easement for a Pipeline for Water Supply purposes over that part of the land shown as 'E-1' on the Plans of Creation of Easement (Ref 2004-P256 and 2004-P257), which are annexed hereto.

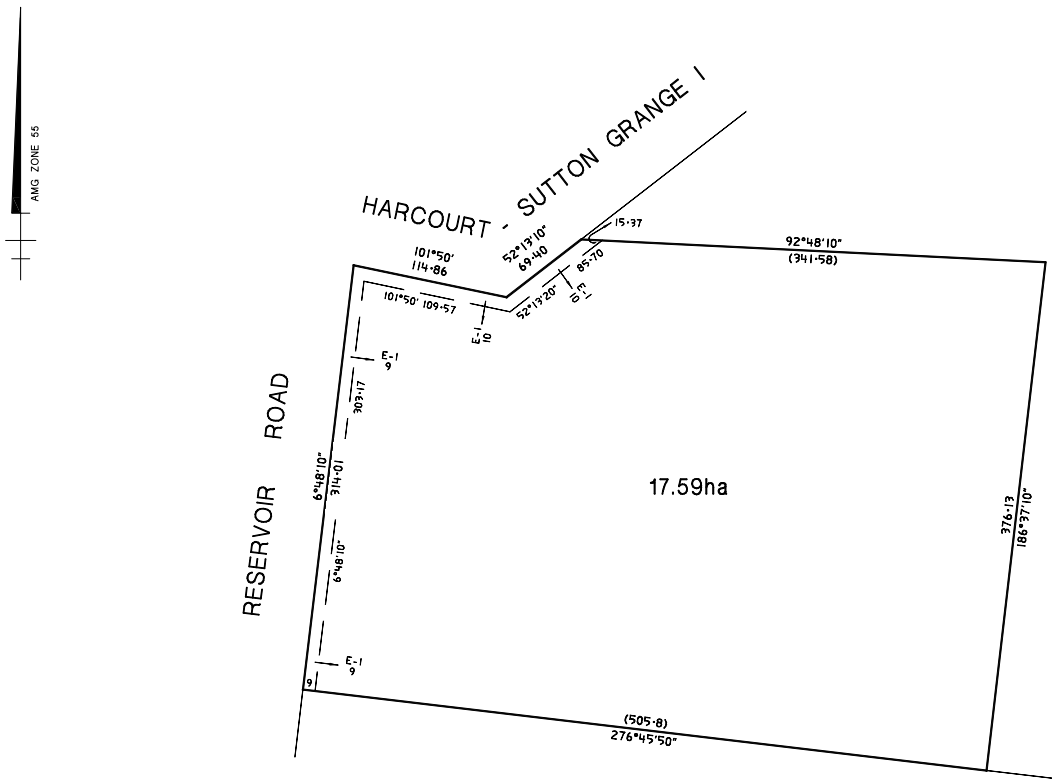

ORIGINAL	SCALE
SCALE SHEET SIZE	25 0 25 50 75 100
1:2500 A3	LENGTHS ARE IN METRES

REF. 2004-P256

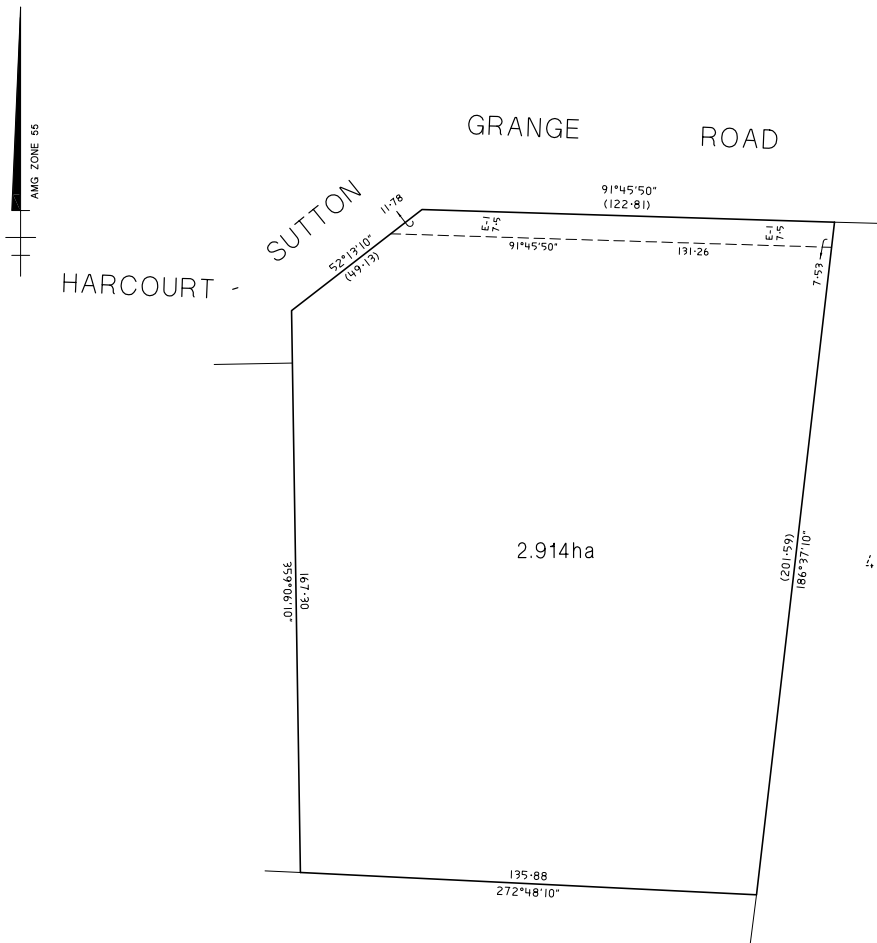

ORIGINAL SCALE
 SCALE SHEET 10 0 10 20 30 40
 SIZE A3 LENGTHS ARE IN METRES REF. 2004-P257

Published with the authority of the Coliban Region Water Corporation.
 For and on behalf of the Coliban Region Water Corporation
 Signed Andrew Cooney
 Name ANDREW COONEY
 Corporate Secretary
 Dated 3 January 2013

Land Acquisition and Compensation Act 1986

FORM 7

S. 21(a)
Reg. 16

Notice of Acquisition

Compulsory Acquisition of Interest in Land

The Coliban Region Water Corporation (ABN 96 549 082 363), of 37-45 Bridge Street, Bendigo 3550, declares that by this notice it acquires the following interest in the land described as Lot 1 on Plan of Subdivision 347229F, being more particularly contained within Certificate of Title Volume 10274 Folio 560:

An Easement for a Pipeline for Water Supply purposes over that part of the land shown as 'E-4' on the Plan of Creation of Easement (Ref 2004-P267), which is annexed hereto.

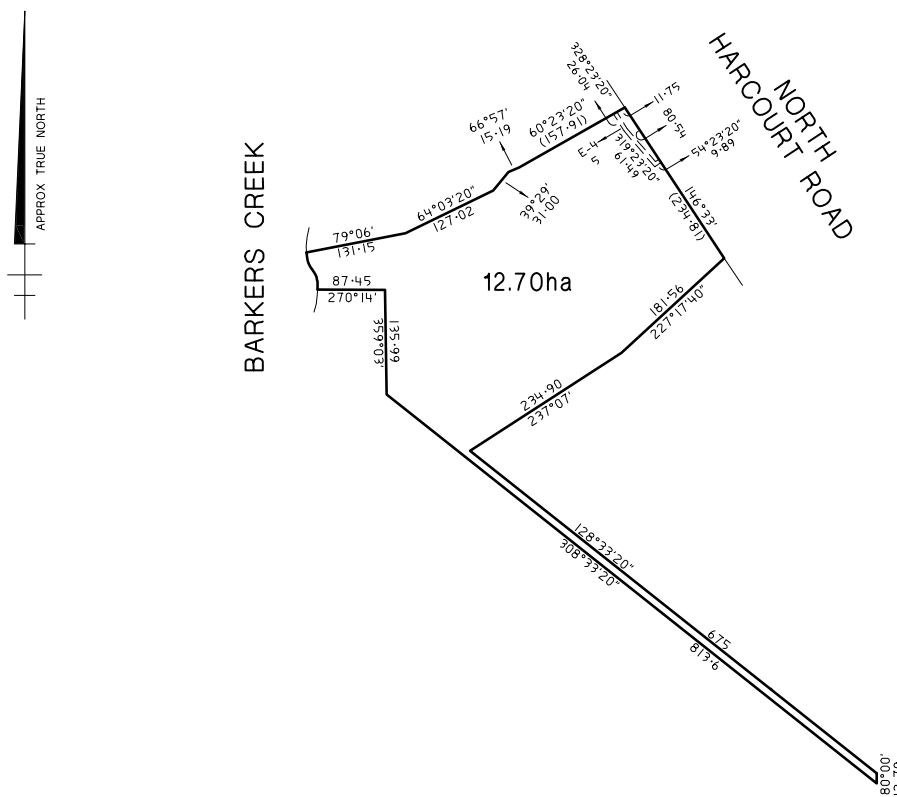

ORIGINAL		SCALE					
SCALE	SHEET SIZE	50	0	50	100	150	200
1:5000	A3	LENGTHS ARE IN METRES					

REF. 2004-P267

Published with the authority of the Coliban Region Water Corporation.
 For and on behalf of the Coliban Region Water Corporation
 Signed Andrew Cooney
 Name ANDREW COONEY
 Corporate Secretary
 Dated 3 January 2013

Land Acquisition and Compensation Act 1986

FORM 7

S. 21(a)
Reg. 16

Notice of Acquisition

Compulsory Acquisition of Interest in Land

The Coliban Region Water Corporation (ABN 96 549 082 363), of 37-45 Bridge Street, Bendigo 3550, declares that by this notice it acquires the following interest in the land described as Lot 1 on Title Plan 104121W, being more particularly contained within Certificate of Title Volume 9578 Folio 301:

An Easement for a Pipeline for Water Supply purposes over that part of the land shown as 'E-1' on the Plan of Creation of Easement (Ref 2004-P276), which is annexed hereto.

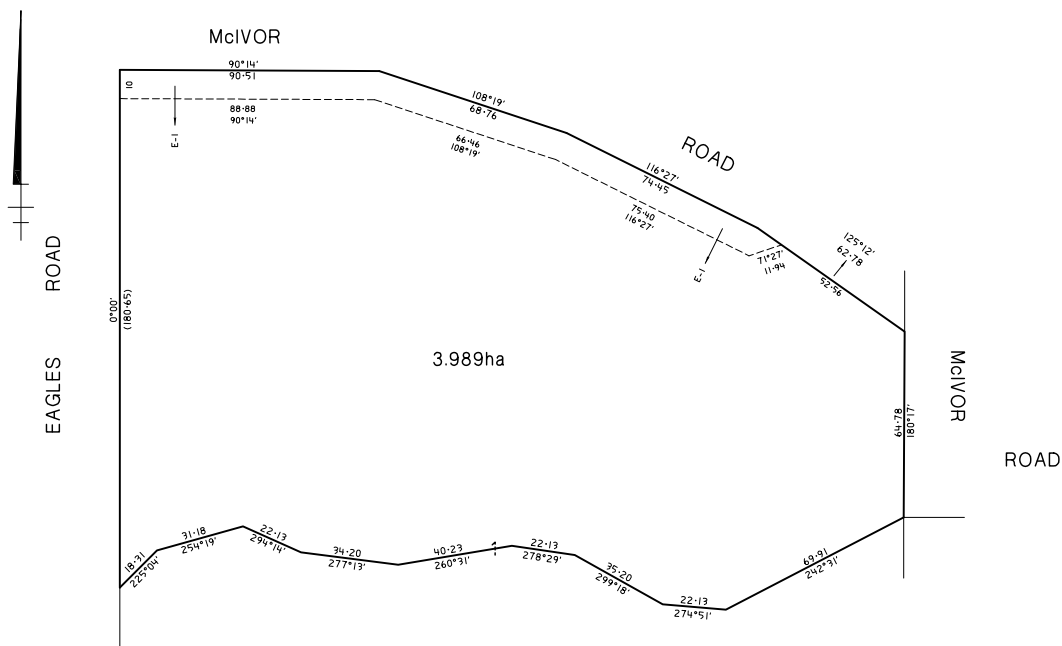

ORIGINAL		SCALE					
SCALE	SHEET SIZE	10	0	10	20	30	40
1:1000	A3	1	1	1	1	1	1
		LENGTHS ARE IN METRES				REF. 2004-P276	

Published with the authority of the Coliban Region Water Corporation.

For and on behalf of the Coliban Region Water Corporation

Signed Andrew Cooney

Name ANDREW COONEY
Corporate Secretary

Dated 3 January 2013

Land Acquisition and Compensation Act 1986

FORM 7

S. 21(a)
Reg. 16

Notice of Acquisition

Compulsory Acquisition of Interest in Land

The Coliban Region Water Corporation (ABN 96 549 082 363), of 37–45 Bridge Street, Bendigo 3550, declares that by this notice it acquires the following interest in the land described as Lot 1 on Title Plan 741495W, being more particularly contained within Certificate of Title Volume 9121 Folio 547:

An Easement for a Pipeline for Water Supply purposes over that part of the land shown as ‘E-2’ on the Plan of Creation of Easement (Ref 2004-P277), which is annexed hereto.

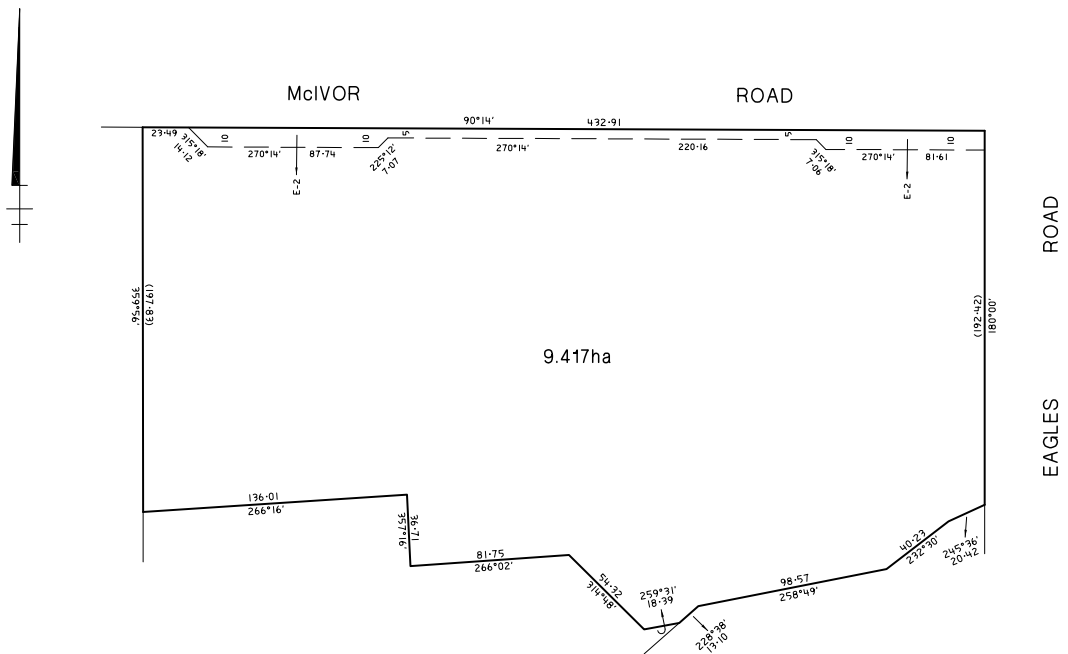

ORIGINAL	SCALE	
SCALE SHEET SIZE	15 0 15 30 45 60	
1:1500 A3	LENGTHS ARE IN METRES	REF. 2004-P277

Published with the authority of the Coliban Region Water Corporation.
 For and on behalf of the Coliban Region Water Corporation
 Signed Andrew Cooney
 Name ANDREW COONEY
 Corporate Secretary
 Dated 3 January 2013

Land Acquisition and Compensation Act 1986

FORM 7

S. 21(a)
Reg. 16

Notice of Acquisition

Compulsory Acquisition of Interest in Land

The Coliban Region Water Corporation (ABN 96 549 082 363), of 37-45 Bridge Street, Bendigo 3550, declares that by this notice it acquires the following interest in the land described as Lot 1 on Plan of Subdivision 313227B, being more particularly contained within Certificate of Title Volume 10061 Folio 230:

An Easement for a Pipeline for Water Supply purposes over that part of the land shown as 'E-5' on the Plan of Creation of Easement (Ref 2004-P279), which is annexed hereto.

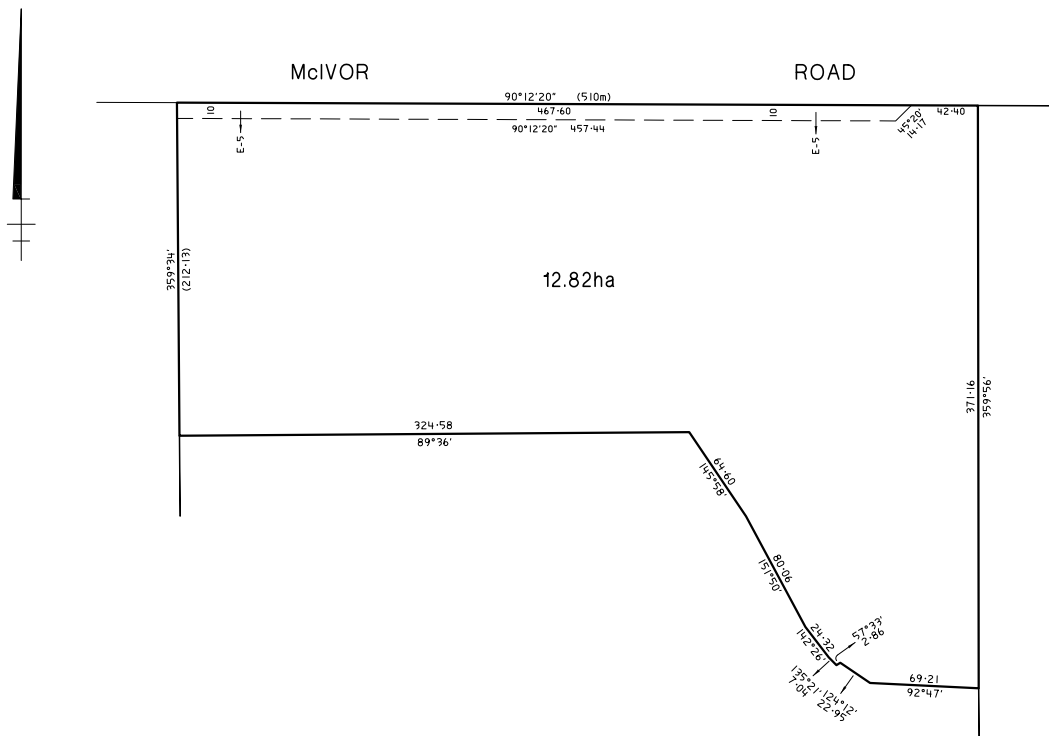

ORIGINAL		SCALE	
SCALE	SHEET SIZE	20 0 20 40 60 80	
1:2000	A3	LENGTHS ARE IN METRES	REF. 2004-P279

Published with the authority of the Coliban Region Water Corporation.

For and on behalf of the Coliban Region Water Corporation

Signed Andrew Cooney
Name ANDREW COONEY
Corporate Secretary

Dated 3 January 2013

Land Acquisition and Compensation Act 1986

FORM 7

S. 21(a)
Reg. 16

Notice of Acquisition

Compulsory Acquisition of Interest in Land

The Coliban Region Water Corporation (ABN 96 549 082 363), of 37-45 Bridge Street, Bendigo 3550, declares that by this notice it acquires the following interest in the land described as Lot 2 on Plan of Subdivision 549430M, being more particularly contained within Certificate of Title Volume 10997 Folio 949:

An Easement for a Pipeline for Water Supply purposes over that part of the land shown as 'E-7' on the Plan of Creation of Easement (Ref 2004-P280), which is annexed hereto.

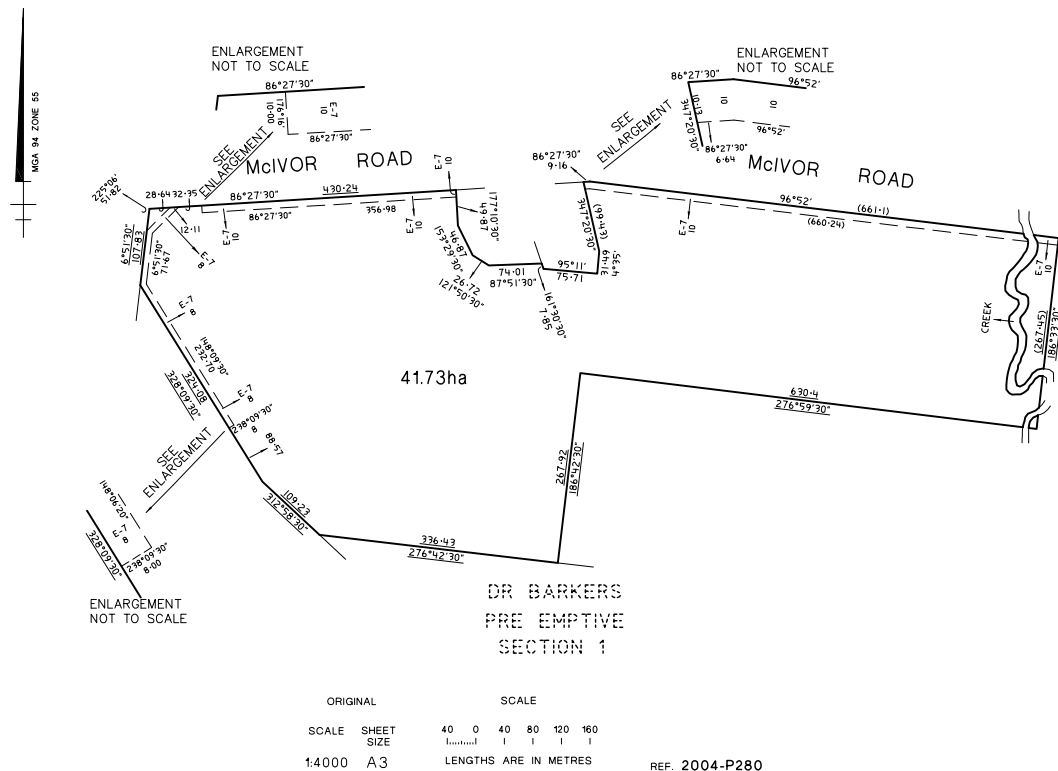

Published with the authority of the Coliban Region Water Corporation.
 For and on behalf of the Coliban Region Water Corporation
 Signed Andrew Cooney
 Name ANDREW COONEY
 Corporate Secretary
 Dated 3 January 2013

Land Acquisition and Compensation Act 1986

FORM 7

S. 21(a)
Reg. 16

Notice of Acquisition

Compulsory Acquisition of Interest in Land

The Coliban Region Water Corporation (ABN 96 549 082 363), of 37-45 Bridge Street, Bendigo 3550, declares that by this notice it acquires the following interest in the land described as Lots 1, 2, 3 and 5 on Title Plan 850001T, being more particularly contained within Certificate of Title Volume 10844 Folio 129:

An Easement for a Pipeline for Water Supply purposes over that part of the land shown as 'E-1' on the Plan of Creation of Easement (Ref 2004-P288), which is annexed hereto.

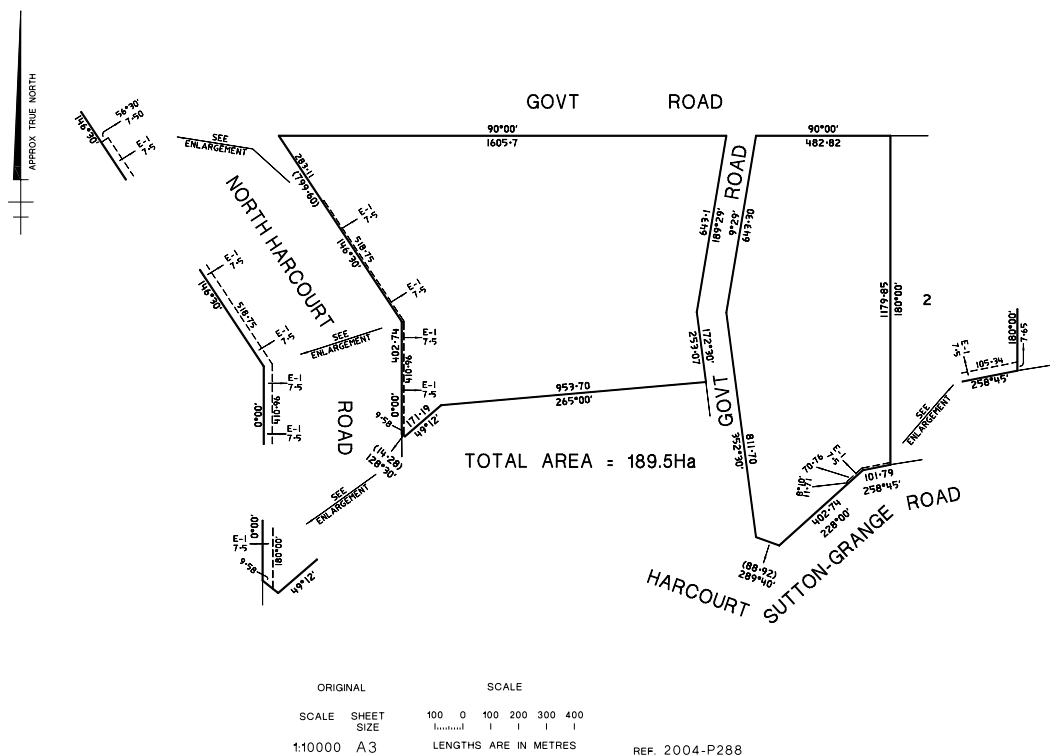

Published with the authority of the Coliban Region Water Corporation.

For and on behalf of the Coliban Region Water Corporation

Signed Andrew Cooney

Name ANDREW COONEY
Corporate Secretary

Dated 3 January 2013

Land Acquisition and Compensation Act 1986

FORM 7

S. 21(a)
Reg. 16

Notice of Acquisition

Compulsory Acquisition of Interest in Land

The Coliban Region Water Corporation (ABN 96 549 082 363), of 37–45 Bridge Street, Bendigo 3550, declares that by this notice it acquires the following interest in the land described as Lot 1 on Plan of Subdivision 549430M, being more particularly contained within Certificate of Title Volume 10997 Folio 948:

An Easement for a Pipeline for Water Supply purposes over that part of the land shown as ‘E-7’ on the Plan of Creation of Easement (Ref 2004-P290), which is annexed hereto.

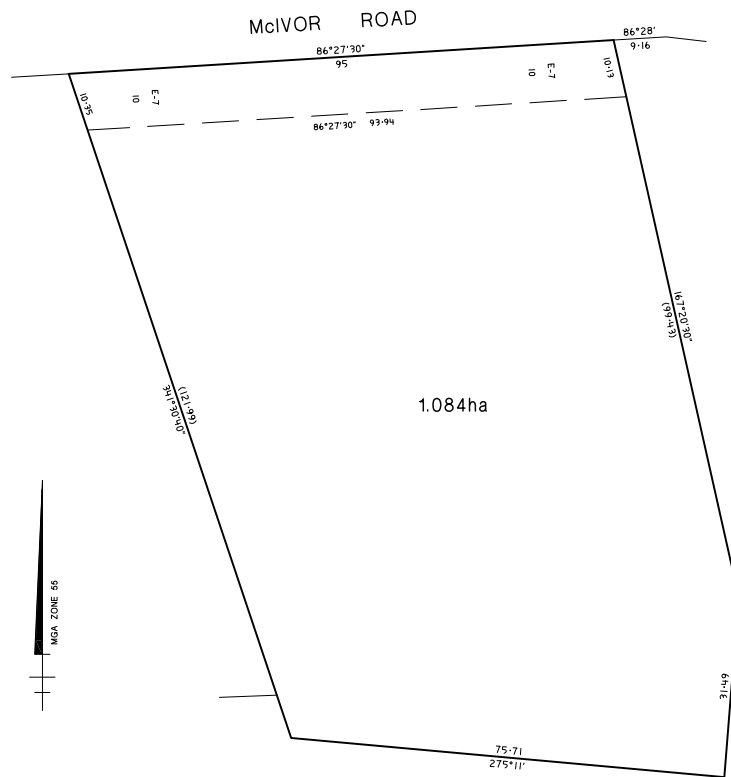

ORIGINAL SCALE
SCALE SHEET SIZE 5 0 5 10 15 20
1:500 A3 LENGTHS ARE IN METRES REF. 2004-P290

Published with the authority of the Coliban Region Water Corporation.
For and on behalf of the Coliban Region Water Corporation
Signed Andrew Cooney
Name ANDREW COONEY
Corporate Secretary
Dated 3 January 2013

Land Acquisition and Compensation Act 1986

FORM 7

S. 21(a)
Reg. 16

Notice of Acquisition

Compulsory Acquisition of Interest in Land

The Coliban Region Water Corporation (ABN 96 549 082 363), of 37-45 Bridge Street, Bendigo 3550, declares that by this notice it acquires the following interest in the land described as Lot 1 on Plan of Subdivision 97419, being more particularly contained within Certificate of Title Volume 9030 Folio 766:

An Easement for a Pipeline for Water Supply purposes over that part of the land shown as 'E-4' on the Plan of Creation of Easement (Ref 2004-P291), which is annexed hereto.

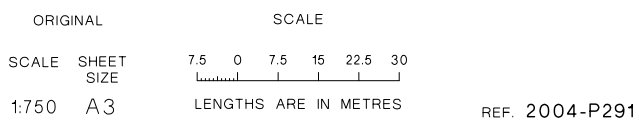
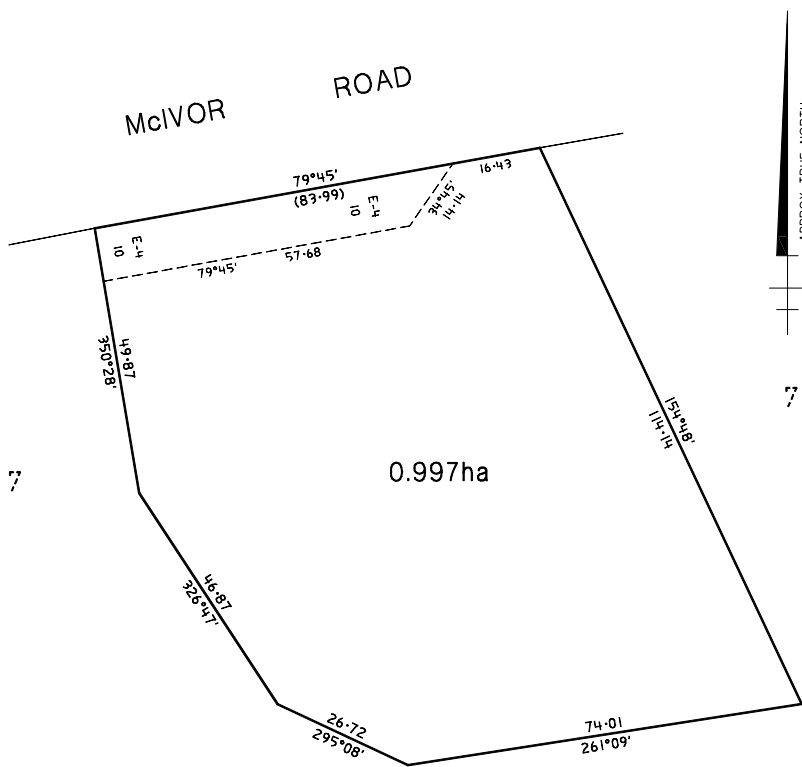

Published with the authority of the Coliban Region Water Corporation.
 For and on behalf of the Coliban Region Water Corporation
 Signed Andrew Cooney
 Name ANDREW COONEY
 Corporate Secretary
 Dated 3 January 2013

Land Acquisition and Compensation Act 1986

FORM 7

S. 21(a)
Reg. 16

Notice of Acquisition

Compulsory Acquisition of Interest in Land

The Coliban Region Water Corporation (ABN 96 549 082 363), of 37–45 Bridge Street, Bendigo 3550, declares that by this notice it acquires the following interest in the land described as Lot 2 on Plan of Subdivision 410762L, being more particularly contained within Certificate of Title Volume 10366 Folio 158:

An Easement for a Pipeline for Water Supply purposes over that part of the land shown as ‘E-5’ on the Plan of Creation of Easement (Ref 2004-P292), which is annexed hereto.

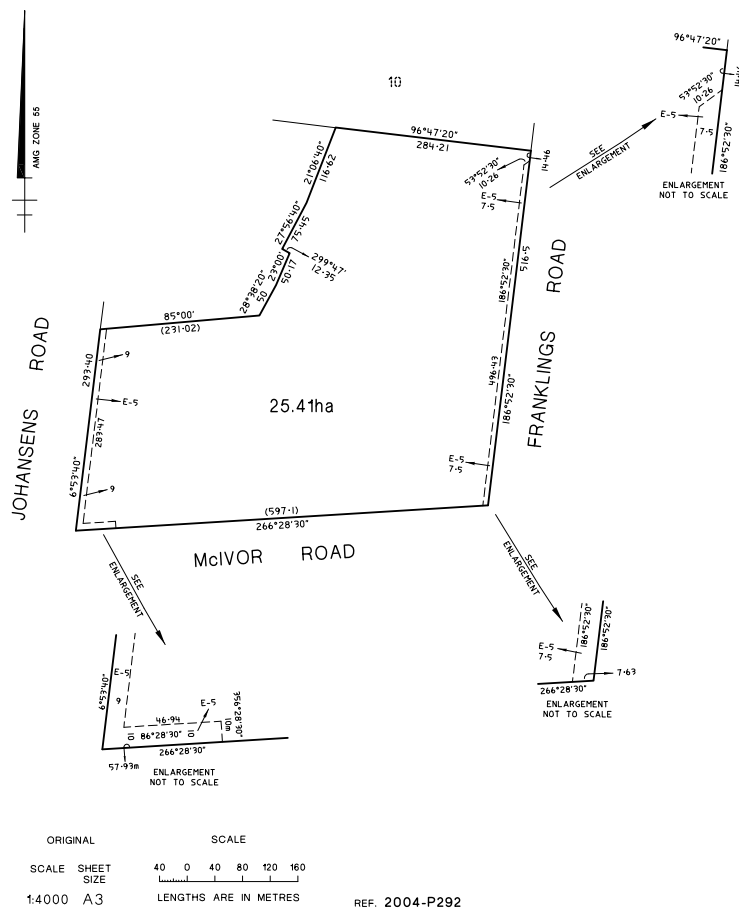

Published with the authority of the Coliban Region Water Corporation.
 For and on behalf of the Coliban Region Water Corporation
 Signed Andrew Cooney
 Name ANDREW COONEY
 Corporate Secretary
 Dated 3 January 2013

Land Acquisition and Compensation Act 1986

FORM 7

S. 21(a)
Reg. 16

Notice of Acquisition

Compulsory Acquisition of Interest in Land

The Coliban Region Water Corporation (ABN 96 549 082 363), of 37–45 Bridge Street, Bendigo 3550, declares that by this notice it acquires the following interest in the land described as Lot 1 on Plan of Subdivision 410762L, being more particularly contained within Certificate of Title Volume 10366 Folio 157:

An Easement for a Pipeline for Water Supply purposes over that part of the land shown as 'E-5' on the Plan of Creation of Easement (Ref 2004-P293), which is annexed hereto.

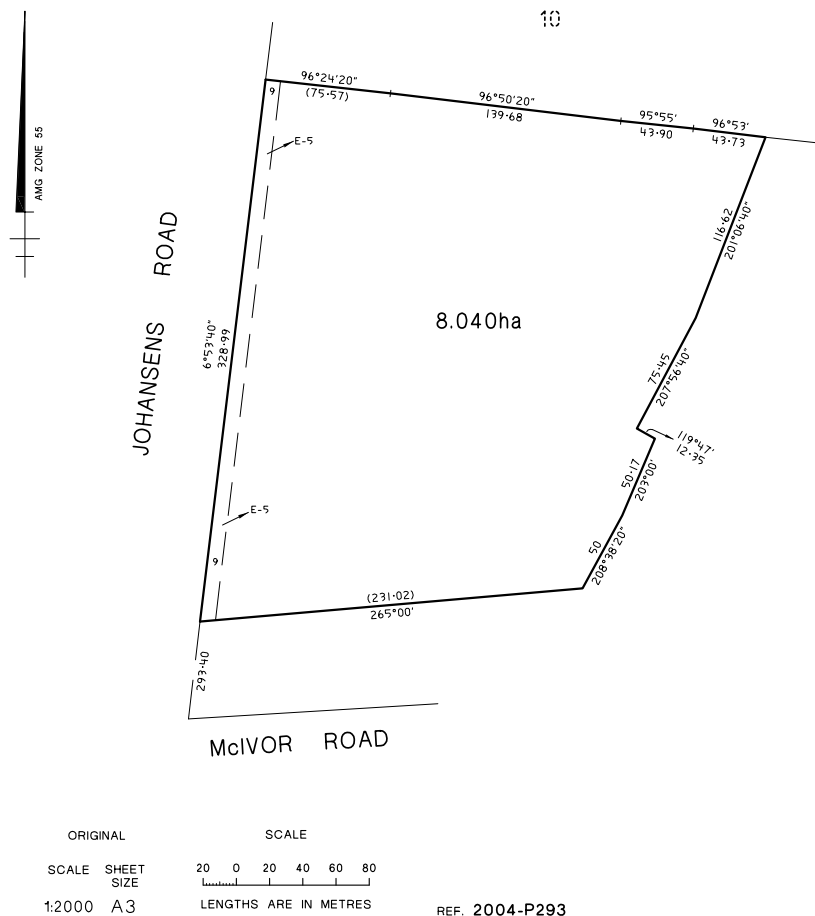

Published with the authority of the Coliban Region Water Corporation.

For and on behalf of the Coliban Region Water Corporation

Signed Andrew Cooney

Name ANDREW COONEY
Corporate Secretary

Dated 3 January 2013

Land Acquisition and Compensation Act 1986

FORM 7

S. 21(a)
Reg. 16

Notice of Acquisition

Compulsory Acquisition of Interest in Land

The Coliban Region Water Corporation (ABN 96 549 082 363), of 37–45 Bridge Street, Bendigo 3550, declares that by this notice it acquires the following interest in the land described as Lot 2 on Plan of Subdivision 221079R, being more particularly contained within Certificate of Title Volume 9992 Folio 429:

An Easement for a Pipeline for Water Supply purposes over that part of the land shown as ‘E-3’ on the Plan of Creation of Easement (Ref 2004-P380), which is annexed hereto.

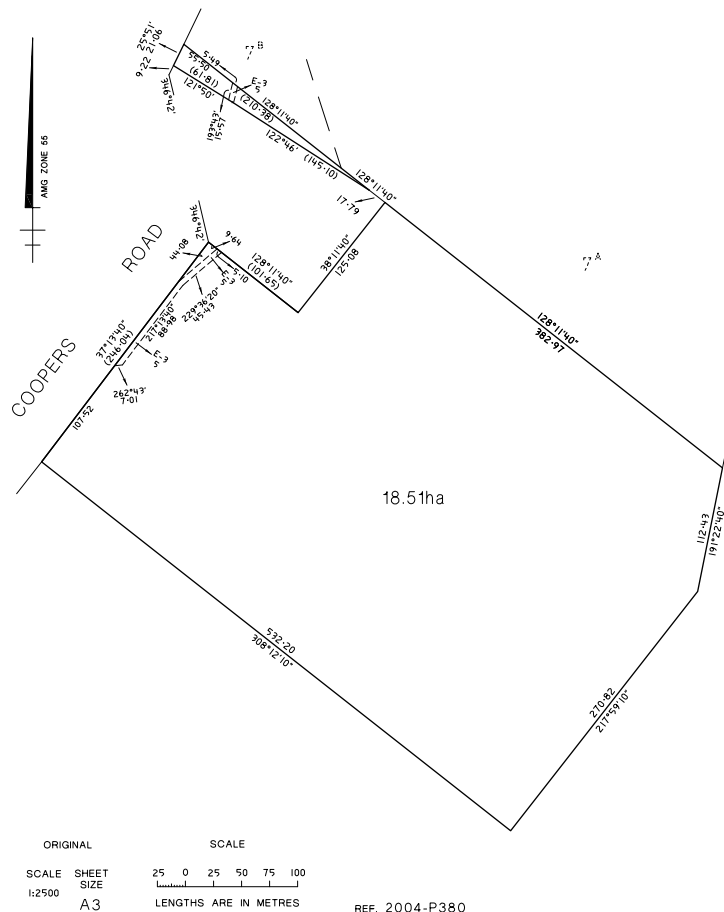

Published with the authority of the Coliban Region Water Corporation.

For and on behalf of the Coliban Region Water Corporation

Signed Andrew Cooney
Name ANDREW COONEY
Corporate Secretary

Dated 3 January 2013

Land Acquisition and Compensation Act 1986

FORM 7

S. 21(a)
Reg. 16

Notice of Acquisition

Compulsory Acquisition of Interest in Land

The Coliban Region Water Corporation (ABN 96 549 082 363), of 37–45 Bridge Street, Bendigo 3550, declares that by this notice it acquires the following interest in the land described as Lot 1 on Plan of Subdivision 545240P, being more particularly contained within Certificate of Title Volume 10929 Folio 085:

An Easement for a Pipeline for Water Supply purposes over that part of the land shown as 'E-3' on the Plan of Creation of Easement (Ref 2004-P388), which is annexed hereto.

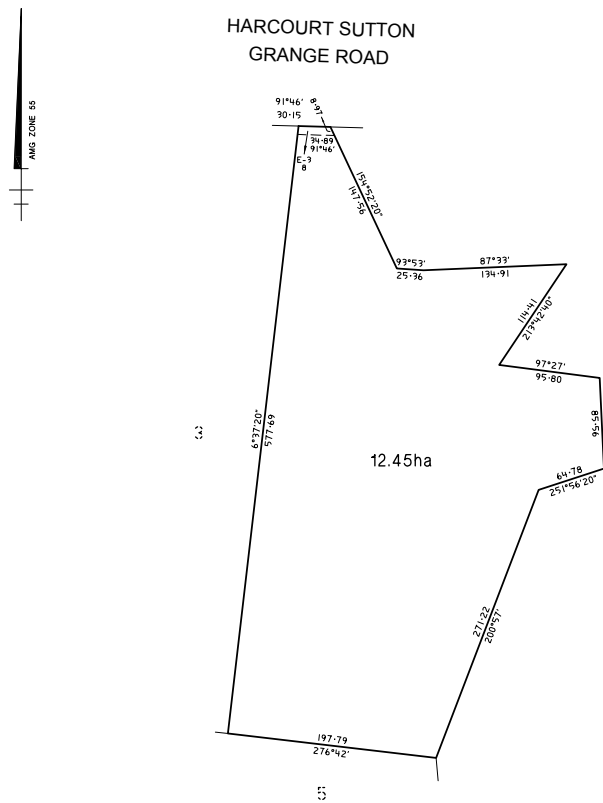

ORIGINAL SCALE
SCALE SHEET SIZE 1:2500 A3
LENGTHS ARE IN METRES
REF. 2004-P388

Published with the authority of the Coliban Region Water Corporation.

For and on behalf of the Coliban Region Water Corporation

Signed Andrew Cooney
Name ANDREW COONEY
Corporate Secretary

Dated 3 January 2013

Land Acquisition and Compensation Act 1986

FORM 7

S. 21(a)
Reg. 16

Notice of Acquisition

Compulsory Acquisition of Interest in Land

The Coliban Region Water Corporation (ABN 96 549 082 363), of 37-45 Bridge Street, Bendigo 3550, declares that by this notice it acquires the following interest in the land described as Lot 2 on Plan of Subdivision 545240P, being more particularly contained within Certificate of Title Volume 10929 Folio 086:

An Easement for a Pipeline for Water Supply purposes over that part of the land shown as 'E-3' on the Plan of Creation of Easement (Ref 2004-P389), which is annexed hereto.

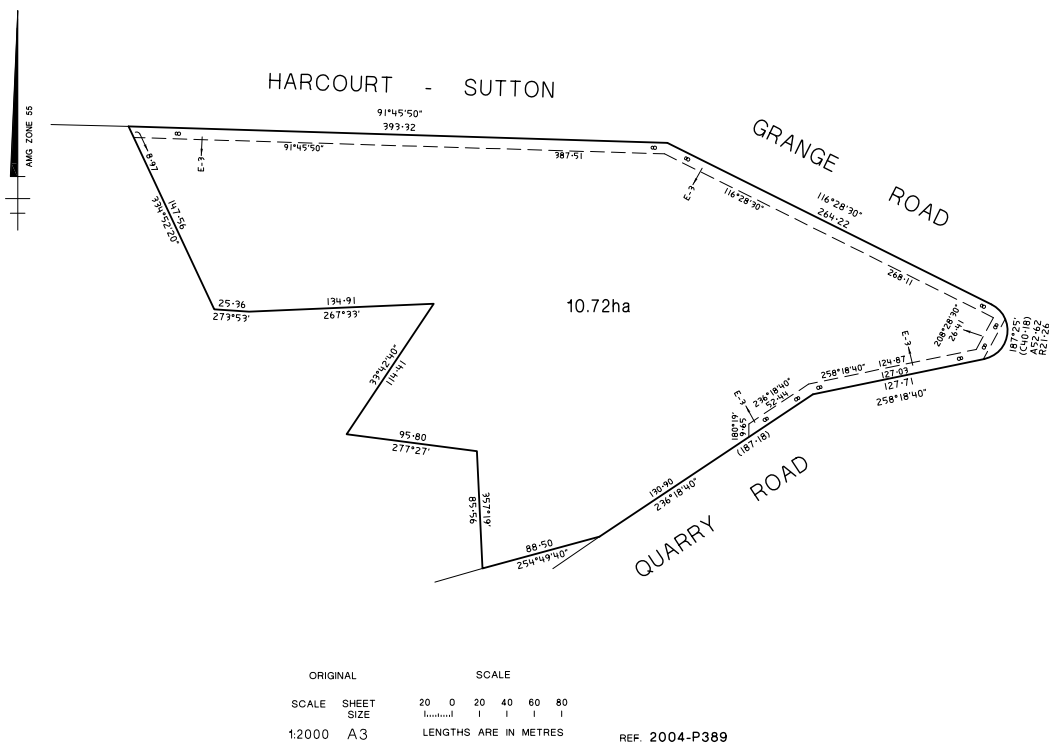

Published with the authority of the Coliban Region Water Corporation.
For and on behalf of the Coliban Region Water Corporation
Signed Andrew Cooney
Name ANDREW COONEY
Corporate Secretary
Dated 3 January 2013

Land Acquisition and Compensation Act 1986

FORM 7

S. 21(a)
Reg. 16

Notice of Acquisition

Compulsory Acquisition of Interest in Land

The Coliban Region Water Corporation (ABN 96 549 082 363), of 37–45 Bridge Street, Bendigo 3550, declares that by this notice it acquires the following interest in the land described as Lots 1, 2 and 3 on Plan of Subdivision 540090J, being more particularly contained within Certificates of Title Volume 7803 Folio 055, Volume 1187 Folio 210 and Volume 0601 Folio 029:

An Easement for a Pipeline for Water Supply purposes over that part of the land shown as ‘E-1’ on the Plans of Creation of Easement (Ref 2004-R003 and 2004-R005), and ‘E-4’ on the Plan of Creation of Easement (Ref 2004-R004), which are annexed hereto.

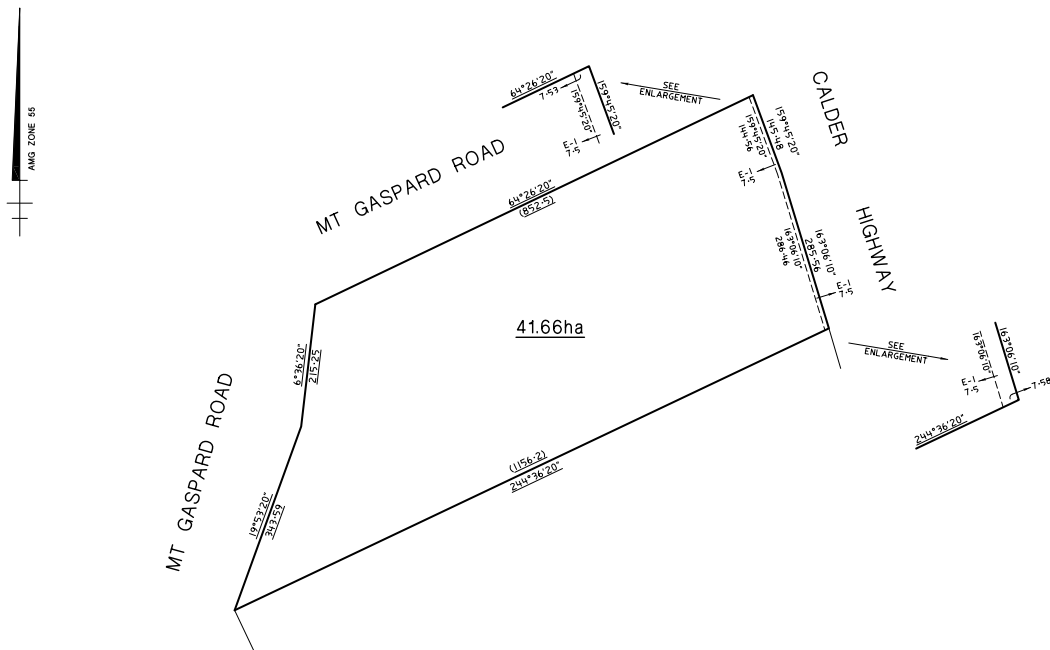

ORIGINAL	SCALE	
SCALE SHEET SIZE	50 0 50 100 150 200	
1:5000 A3	LENGTHS ARE IN METRES	REF. 2004-R003

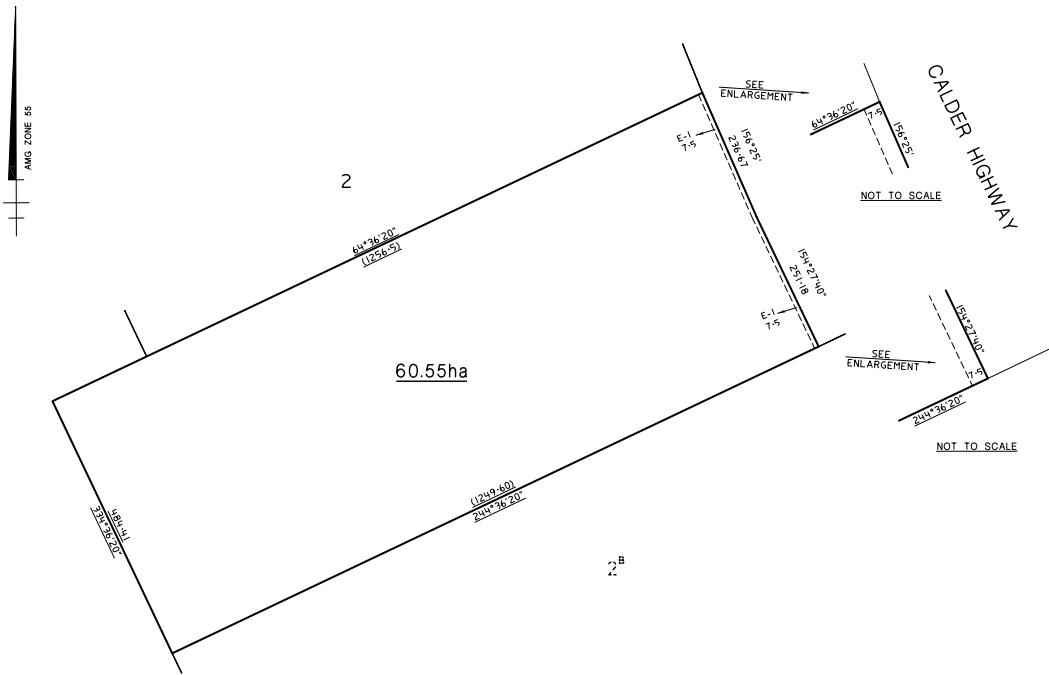

ORIGINAL		SCALE					
SCALE	SHEET SIZE	50	0	50	100	150	200
1:5000	A3	LENGTHS ARE IN METRES					

REF. 2004-R005

Land Acquisition and Compensation Act 1986

FORM 7

S. 21(a)
Reg. 16

Notice of Acquisition

Compulsory Acquisition of Interest in Land

The Coliban Region Water Corporation (ABN 96 549 082 363), of 37-45 Bridge Street, Bendigo 3550, declares that by this notice it acquires the following interest in the land described as Lot 1 on Plan of Subdivision 608938W, being more particularly contained within Certificate of Title Volume 11085 Folio 744:

An Easement for a Pipeline for Water Supply purposes over that part of the land shown as 'E-5' on the Plan of Creation of Easement (Ref 2004-R007), which is annexed hereto.

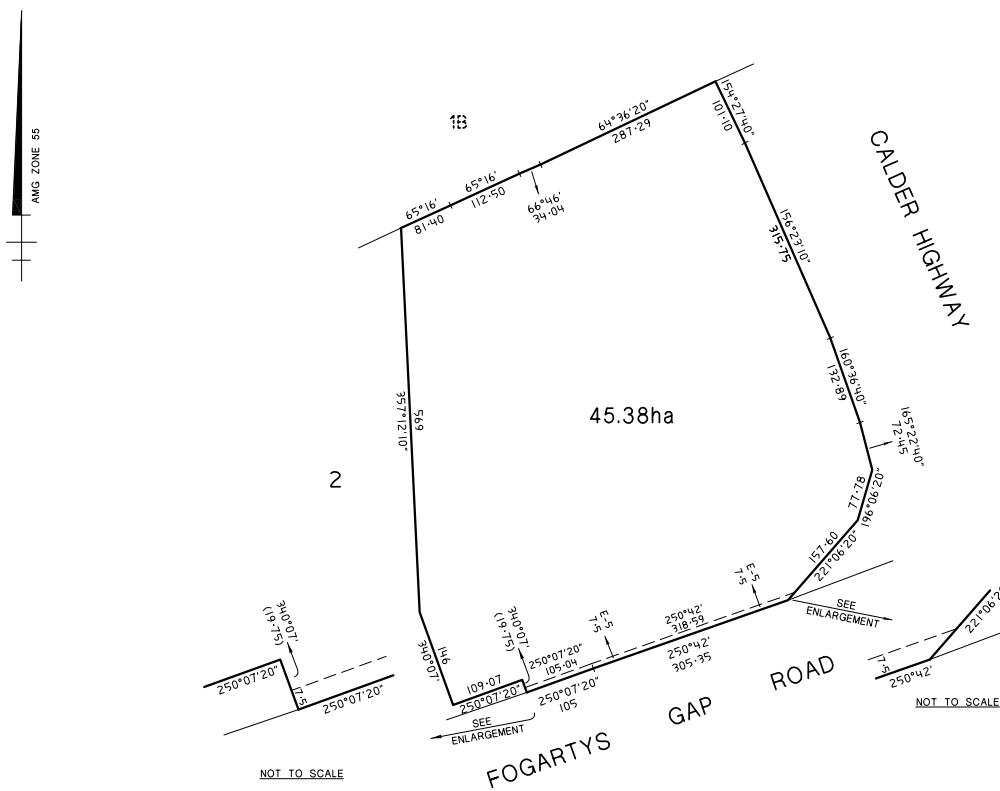

ORIGINAL		SCALE					
SCALE	SHEET SIZE	50	0	50	100	150	200
1:5000	A3	LENGTHS ARE IN METRES					

REF. 2004-R007

Published with the authority of the Coliban Region Water Corporation.
 For and on behalf of the Coliban Region Water Corporation
 Signed Andrew Cooney
 Name ANDREW COONEY
 Corporate Secretary
 Dated 3 January 2013

Land Acquisition and Compensation Act 1986

FORM 7

S. 21(a)
Reg. 16

Notice of Acquisition

Compulsory Acquisition of Interest in Land

The Coliban Region Water Corporation (ABN 96 549 082 363), of 37–45 Bridge Street, Bendigo 3550, declares that by this notice it acquires the following interest in the land described as Lot 1 on Plan of Subdivision 629338E, being more particularly contained within Certificate of Title Volume 11151 Folio 373:

An Easement for a Pipeline for Water Supply purposes over that part of the land shown as ‘E-1’ on the Plan of Creation of Easement (Ref 2004-R046), which is annexed hereto.

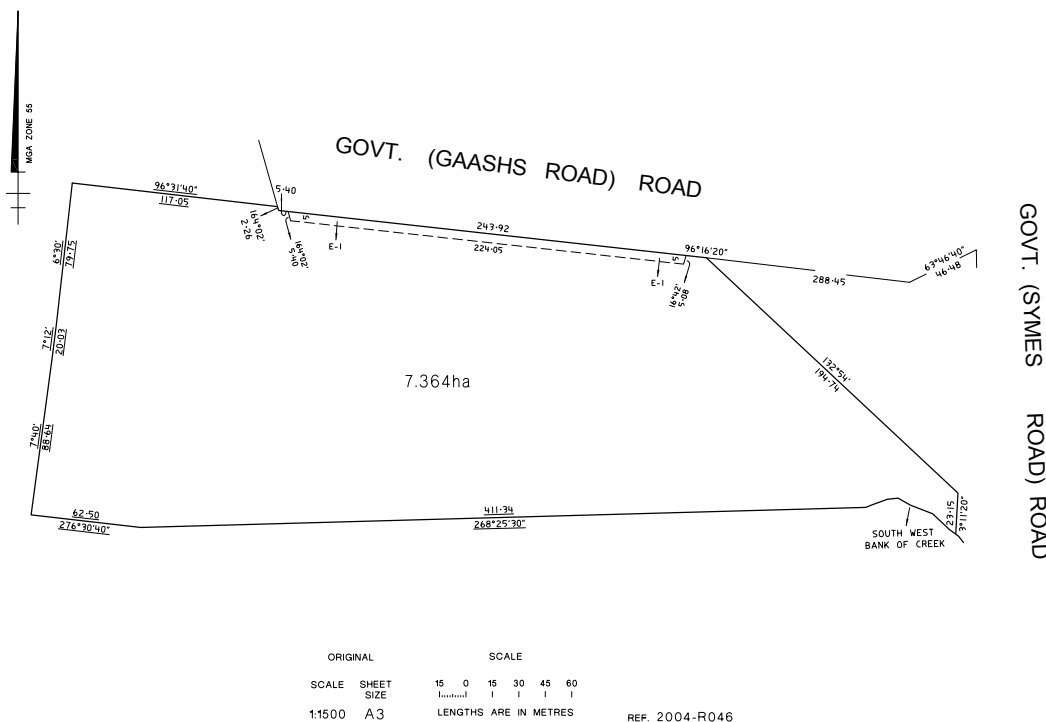

Published with the authority of the Coliban Region Water Corporation.

For and on behalf of the Coliban Region Water Corporation

Signed Andrew Cooney
Name ANDREW COONEY
Corporate Secretary

Dated 3 January 2013

Land Acquisition and Compensation Act 1986

FORM 7

S. 21(a)
Reg. 16

Notice of Acquisition

Compulsory Acquisition of Interest in Land

The Coliban Region Water Corporation (ABN 96 549 082 363), of 37–45 Bridge Street, Bendigo 3550, declares that by this notice it acquires the following interest in the land described as Crown Allotment 15 Section 5 Parish of Harcourt, being more particularly contained within Certificate of Title Volume 9077 Folio 982:

An Easement for a Pipeline for Water Supply purposes over that part of the land shown as ‘E-1’ on the Plan of Creation of Easement (Ref 2004-R058), which is annexed hereto.

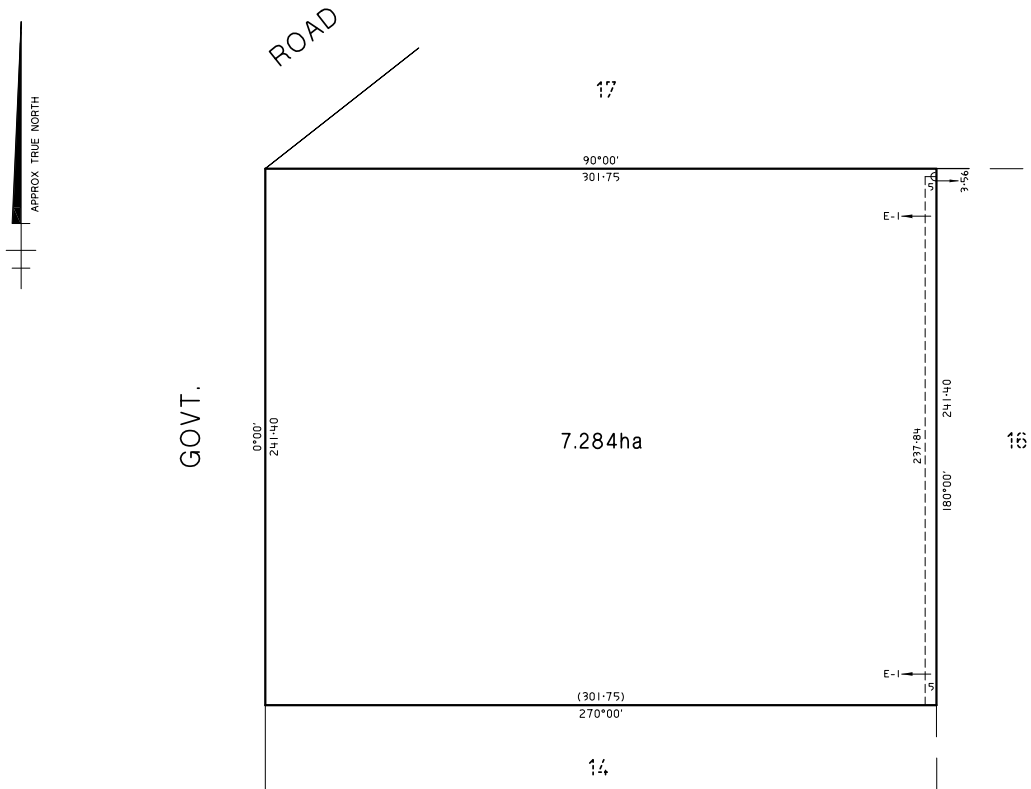

ORIGINAL		SCALE					
SCALE	SHEET SIZE	15	0	15	30	45	60
1:1500	A3	LENGTHS ARE IN METRES					

REF. 2004-R058

Published with the authority of the Coliban Region Water Corporation.
 For and on behalf of the Coliban Region Water Corporation
 Signed Andrew Cooney
 Name ANDREW COONEY
 Corporate Secretary
 Dated 3 January 2013

Land Acquisition and Compensation Act 1986

FORM 7

S. 21(a)
Reg. 16

Notice of Acquisition

Compulsory Acquisition of Interest in Land

The Coliban Region Water Corporation (ABN 96 549 082 363), of 37–45 Bridge Street, Bendigo 3550, declares that by this notice it acquires the following interest in the land described as Crown Allotments 12 and 16 Section 5 Parish of Harcourt, being more particularly contained within Certificates of Title Volume 10945 Folio 157 and Volume 1254 Folio 691:

An Easement for a Pipeline for Water Supply purposes over that part of the land shown as 'E-1' on the Plans of Creation of Easement (Ref 2004-R059 and 2004-R061), which are annexed hereto.

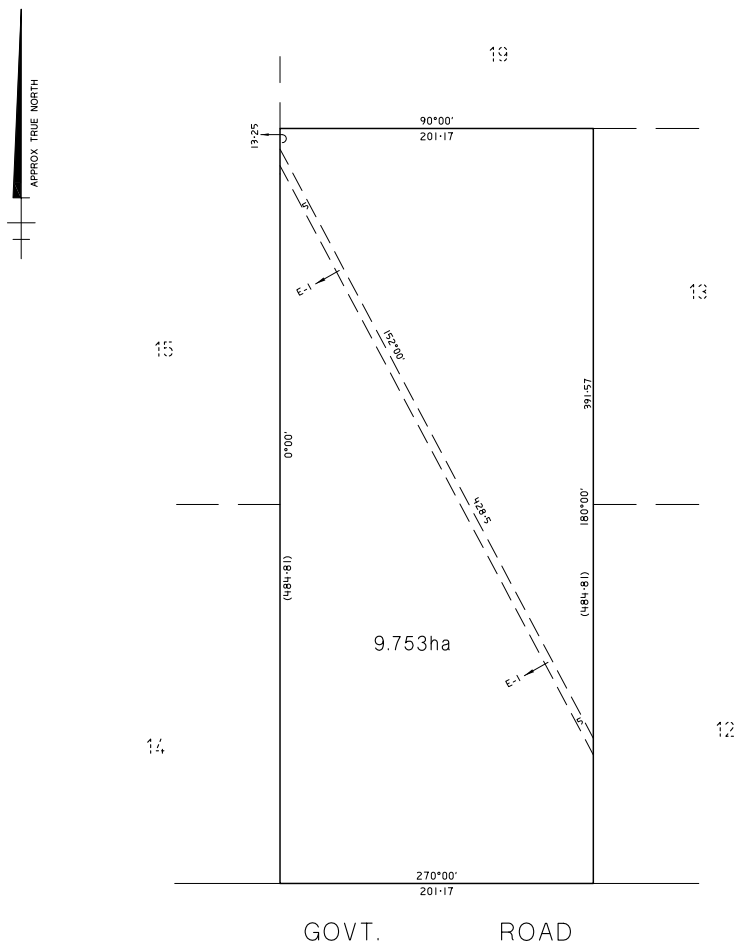

ORIGINAL SCALE
SCALE SHEET SIZE
1:2000 A3
20 0 20 40 60 80
LENGTHS ARE IN METRES
REF. 2004-R059

Land Acquisition and Compensation Act 1986

FORM 7

S. 21(a)
Reg. 16

Notice of Acquisition

Compulsory Acquisition of Interest in Land

The Coliban Region Water Corporation (ABN 96 549 082 363), of 37–45 Bridge Street, Bendigo 3550, declares that by this notice it acquires the following interest in the land described as Lot 1 on Plan of Subdivision 616818M, being more particularly contained within Certificate of Title Volume 11288 Folio 260:

An Easement for a Pipeline for Water Supply purposes over that part of the land shown as 'E-1' on the Plan of Creation of Easement (Ref 2004-R085), which is annexed hereto.

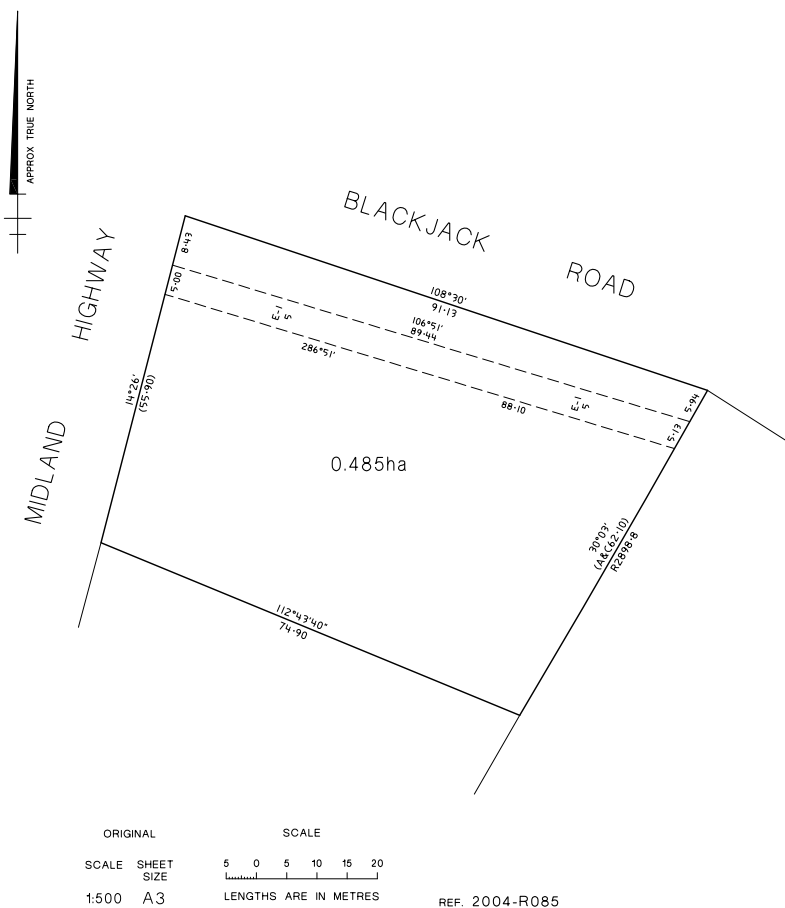

Published with the authority of the Coliban Region Water Corporation.

For and on behalf of the Coliban Region Water Corporation

Signed Andrew Cooney
Name ANDREW COONEY
Corporate Secretary

Dated 3 January 2013

Land Acquisition and Compensation Act 1986

FORM 7

S. 21(a)
Reg. 16

Notice of Acquisition

Compulsory Acquisition of Interest in Land

The Coliban Region Water Corporation (ABN 96 549 082 363), of 37–45 Bridge Street, Bendigo 3550, declares that by this notice it acquires the following interest in the land described as Lot 4 on Plan of Subdivision 546453Q and Crown Allotments 1 and 1A Section 5C Parish of Harcourt, being more particularly contained within Certificates of Title Volume 11261 Folios 680 and 681:

An Easement for a Pipeline for Water Supply purposes over that part of the land shown as 'E-1' on the Plan of Creation of Easement (Ref 2004-R094-1) and 'E-2' on the Plan of Creation of Easement (Ref 2004-R094-2), which are annexed hereto.

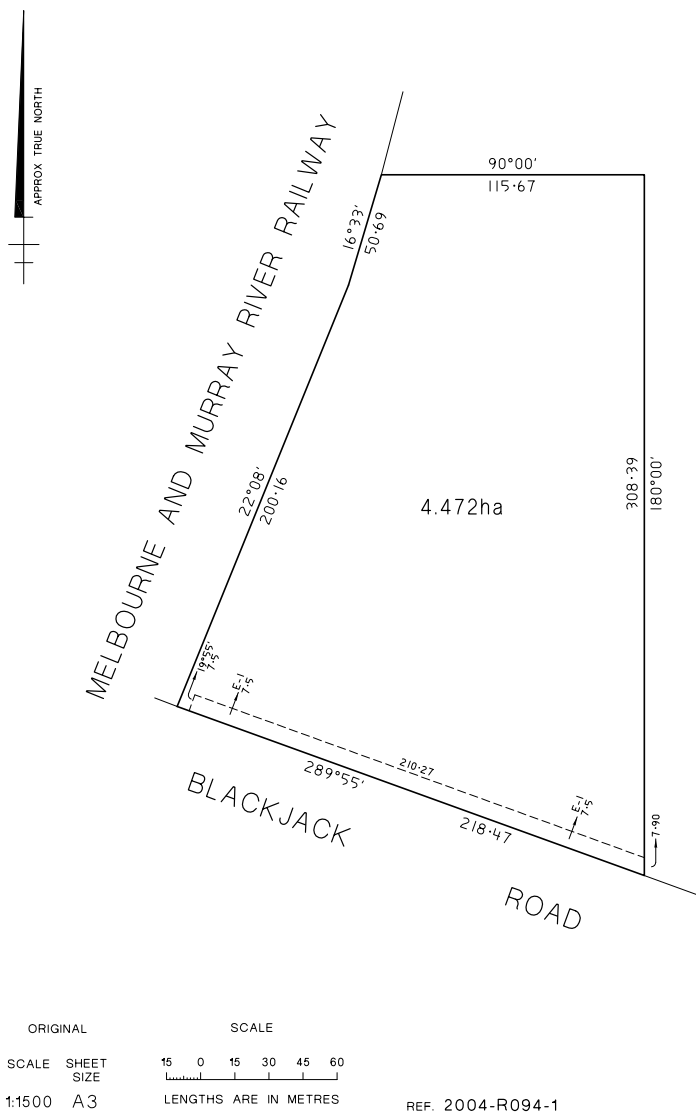

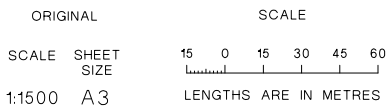
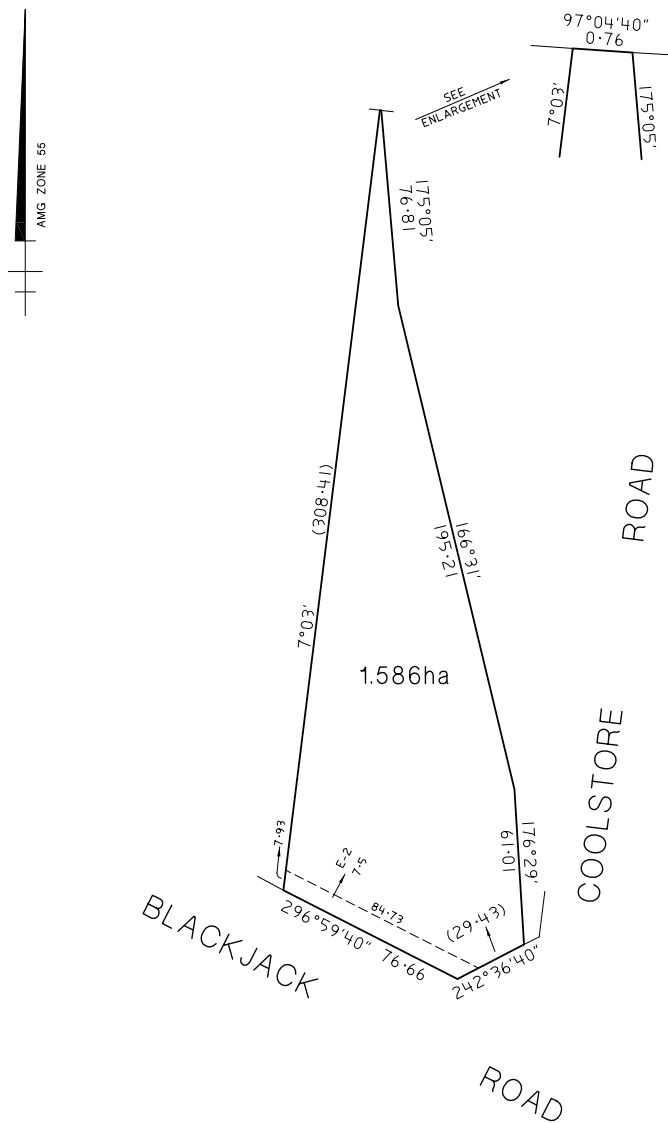

REF. 2004-R094-2

Published with the authority of the Coliban Region Water Corporation.
 For and on behalf of the Coliban Region Water Corporation
 Signed Andrew Cooney
 Name ANDREW COONEY
 Corporate Secretary
 Dated 3 January 2013

Land Acquisition and Compensation Act 1986

FORM 7

S. 21(a)
Reg. 16

Notice of Acquisition

Compulsory Acquisition of Interest in Land

The Coliban Region Water Corporation (ABN 96 549 082 363), of 37-45 Bridge Street, Bendigo 3550, declares that by this notice it acquires the following interest in the land described as Lot 1 on Title Plan 326291F, being more particularly contained within Certificate of Title Volume 8104 Folio 377:

An Easement for a Pipeline for Water Supply purposes over that part of the land shown as 'E-1' on the Plan of Creation of Easement (Ref 2004-R099), which is annexed hereto.

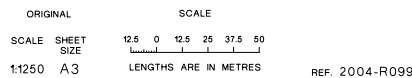
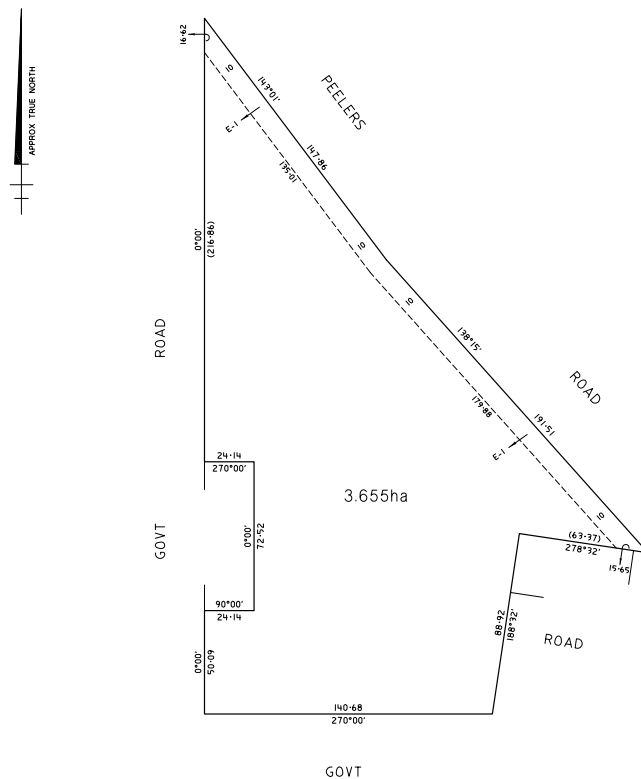

Published with the authority of the Coliban Region Water Corporation.
 For and on behalf of the Coliban Region Water Corporation
 Signed Andrew Cooney
 Name ANDREW COONEY
 Corporate Secretary
 Dated 3 January 2013

Land Acquisition and Compensation Act 1986

FORM 7

S. 21(a)
Reg. 16

Notice of Acquisition

Compulsory Acquisition of Interest in Land

The Coliban Region Water Corporation (ABN 96 549 082 363), of 37-45 Bridge Street, Bendigo 3550, declares that by this notice it acquires the following interest in the land described as Lot 1 on Title Plan 82431W and Lot 1 on Title Plan 1164B, being more particularly contained within Certificates of Title Volume 10063 Folio 522 and Volume 10154 Folio 040:

An Easement for a Pipeline for Water Supply purposes over that part of the land shown as 'E-1' on the Plans of Creation of Easement (Ref 2004-R147 and 2004-R210), which are annexed hereto.

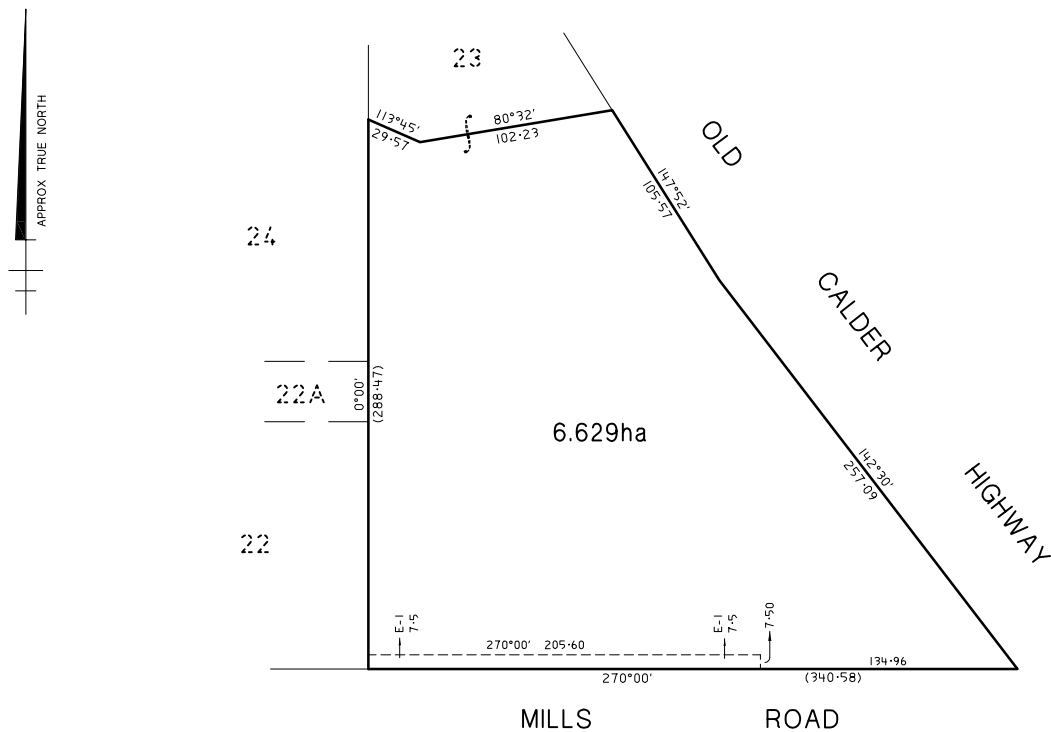

ORIGINAL	SCALE	
SCALE SHEET SIZE	20 0 20 40 60 80	
1:2000 A3	LENGTHS ARE IN METRES	REF. 2004-R147

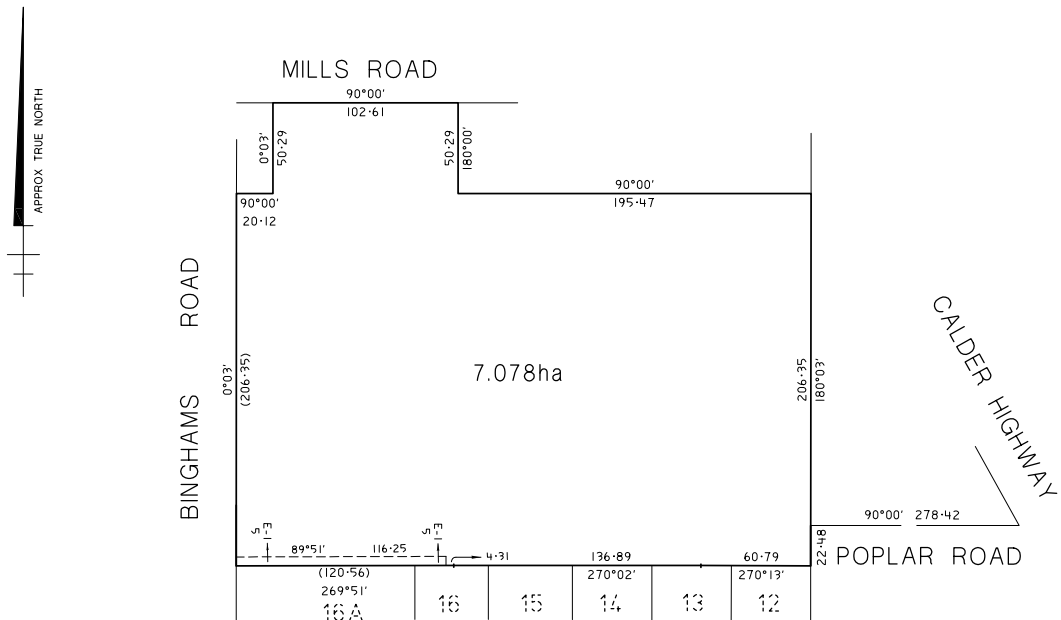

ORIGINAL SCALE
 SCALE SHEET SIZE 20 0 20 40 60 80
 1:2000 A3 LENGTHS ARE IN METRES REF. 2004-R210

Published with the authority of the Coliban Region Water Corporation.
 For and on behalf of the Coliban Region Water Corporation
 Signed Andrew Cooney
 Name ANDREW COONEY
 Corporate Secretary
 Dated 3 January 2013

Land Acquisition and Compensation Act 1986

FORM 7

S. 21(a)
Reg. 16

Notice of Acquisition

Compulsory Acquisition of Interest in Land

The Coliban Region Water Corporation (ABN 96 549 082 363), of 37-45 Bridge Street, Bendigo 3550, declares that by this notice it acquires the following interest in the land described as Crown Allotment 12 Section 9 Parish of Harcourt and Lots 1, 6 and 7 on Title Plan 833532G, being more particularly contained within Certificates of Title Volume 4459 Folio 685 and Volume 6104 Folio 663:

An Easement for a Pipeline for Water Supply purposes over that part of the land shown as 'E-1' on the Plan of Creation of Easement (Ref 2004-R152) and 'E-2' on the Plan of Creation of Easement (Ref 2004-R341), which are annexed hereto.

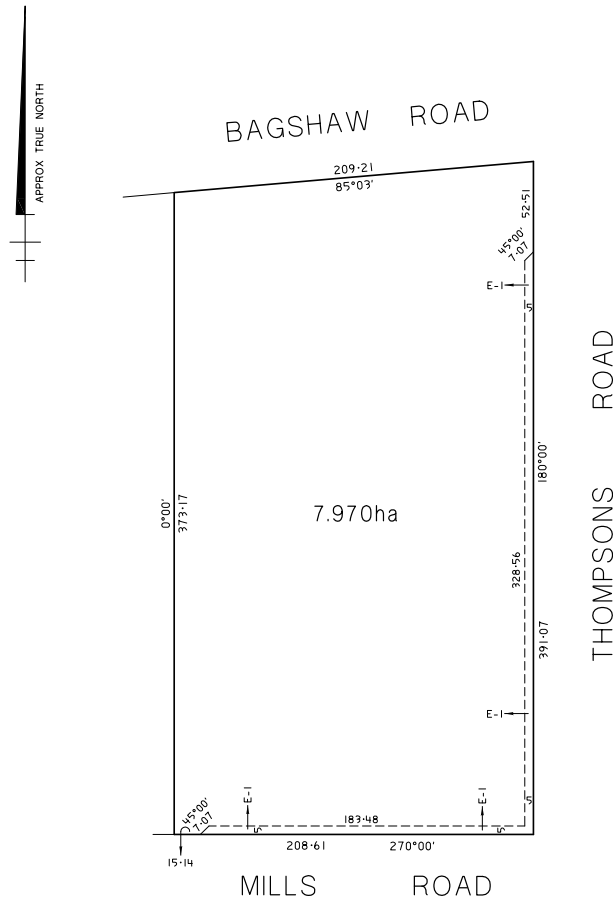

ORIGINAL SCALE
SCALE SHEET SIZE
1:2000 A3

SCALE
20 0 20 40 60 80
LENGTHS ARE IN METRES

REF. 2004-R152

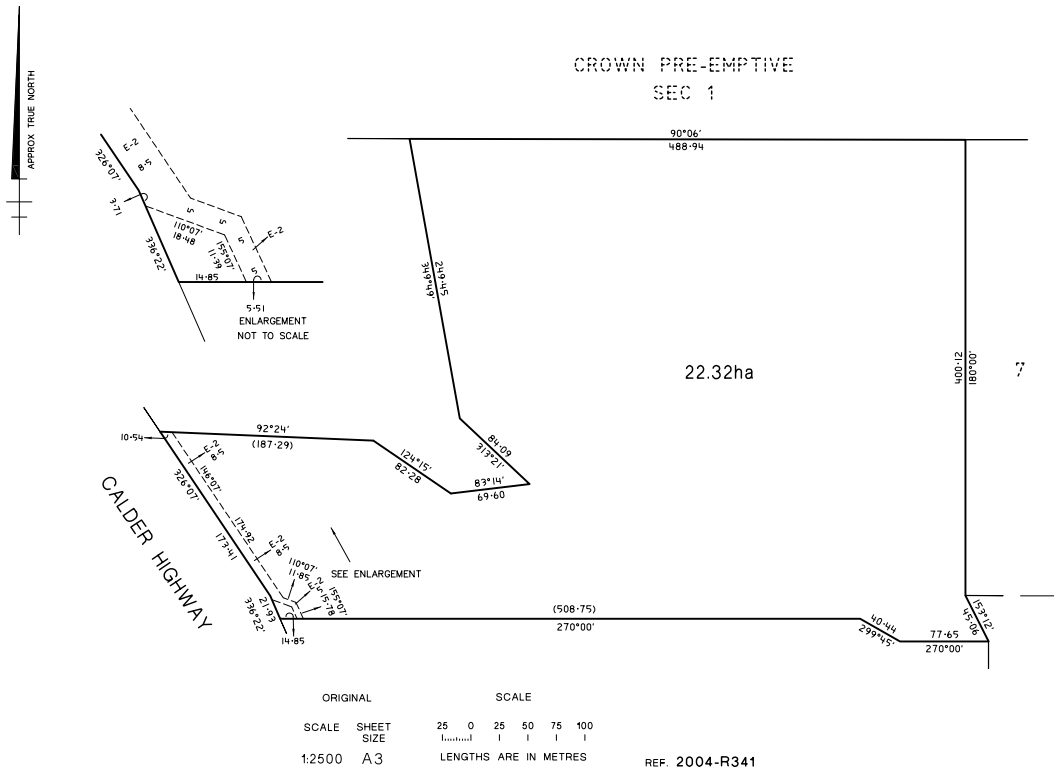

Published with the authority of the Coliban Region Water Corporation.
 For and on behalf of the Coliban Region Water Corporation
 Signed Andrew Cooney
 Name ANDREW COONEY
 Corporate Secretary
 Dated 3 January 2013

Land Acquisition and Compensation Act 1986
FORM 7

S. 21(a)
 Reg. 16

Notice of Acquisition

Compulsory Acquisition of Interest in Land

The Coliban Region Water Corporation (ABN 96 549 082 363), of 37–45 Bridge Street, Bendigo 3550, declares that by this notice it acquires the following interest in the land described as Crown Allotment 7 Section 6A and Crown Allotment 11 Section 7A Township of Harcourt Parish of Harcourt, being more particularly contained within Certificates of Title Volume 11324 Folios 140, 141 and 142 and Title Volume 9986 Folio 708:

An Easement for a Pipeline for Water Supply purposes over that part of the land shown as 'E-1' on the Plan of Creation of Easement (Ref 2004-R158 and 2004-R174), which is annexed hereto.

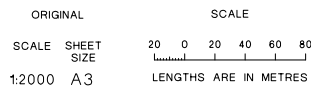
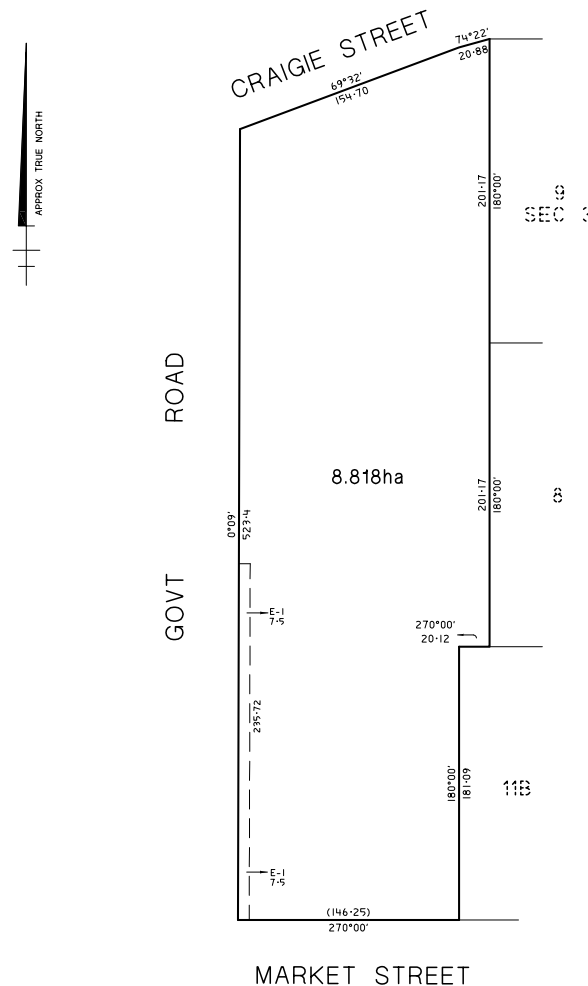

REF. 2004-R158

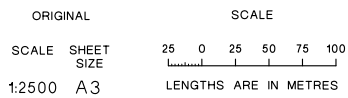
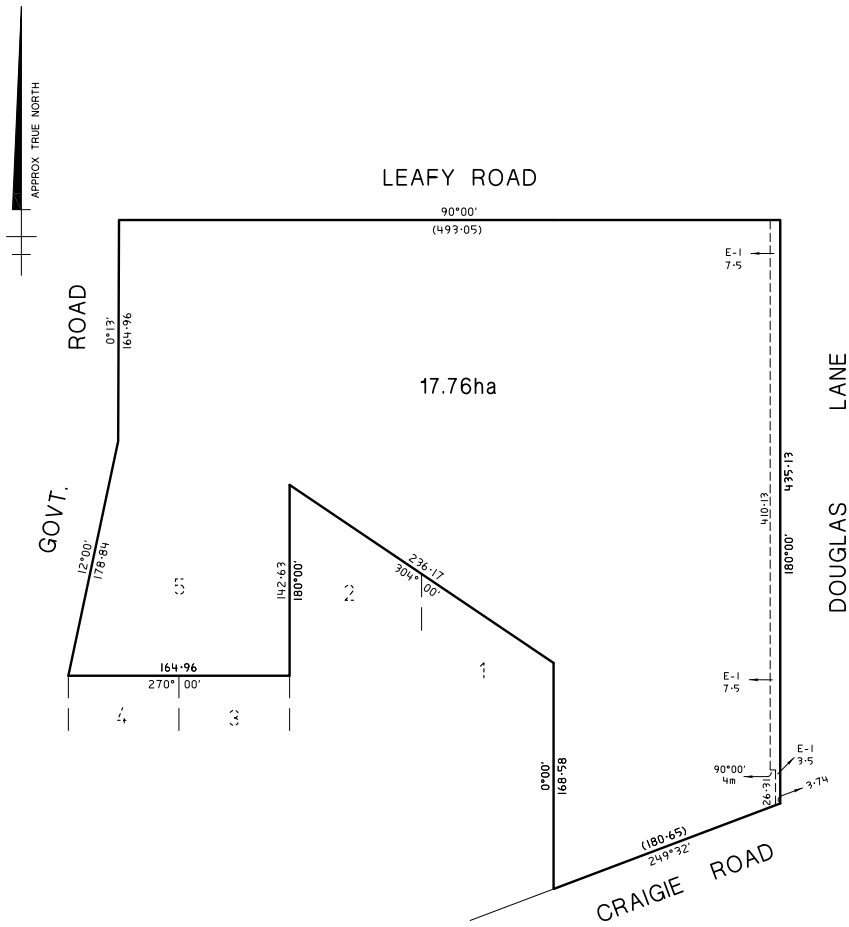

REF. 2004-R174

Published with the authority of the Coliban Region Water Corporation.
 For and on behalf of the Coliban Region Water Corporation
 Signed Andrew Cooney
 Name ANDREW COONEY
 Corporate Secretary
 Dated 3 January 2013

Land Acquisition and Compensation Act 1986
FORM 7

S. 21(a)
 Reg. 16

Notice of Acquisition

Compulsory Acquisition of Interest in Land

The Coliban Region Water Corporation (ABN 96 549 082 363), of 37-45 Bridge Street, Bendigo 3550, declares that by this notice it acquires the following interest in the land described as Crown Allotments 10 and 11 Section 5A Township of Harcourt Parish of Harcourt, being more particularly contained within Certificate of Title Volume 9842 Folio 549:

An Easement for a Pipeline for Water Supply purposes over that part of the land shown as 'E-1' on the Plan of Creation of Easement (Ref 2004-R178), which is annexed hereto.

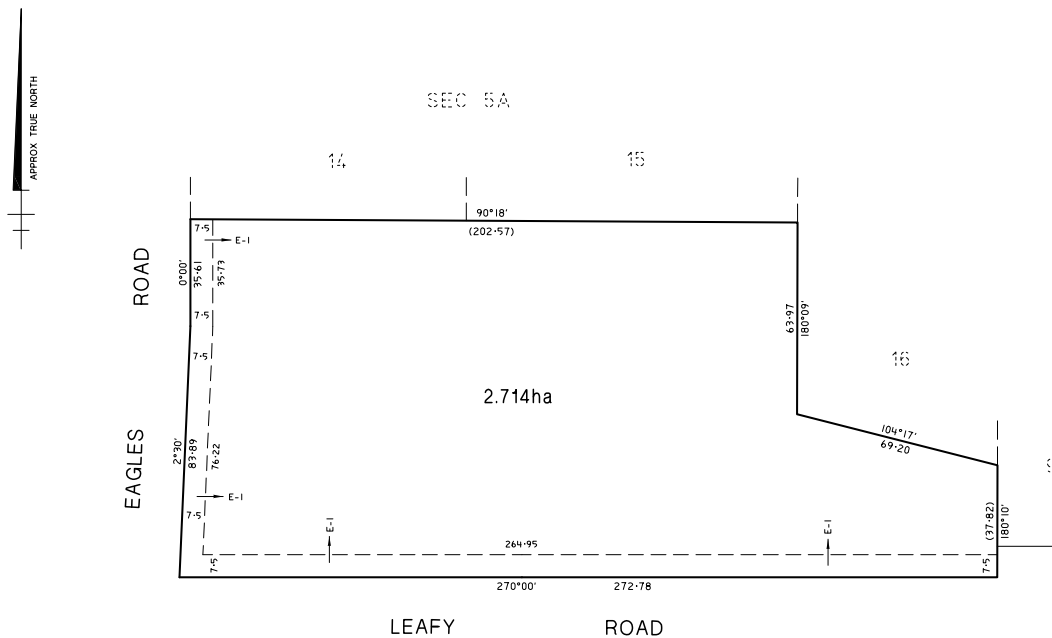

ORIGINAL		SCALE					
SCALE	SHEET SIZE	10	0	10	20	30	40
1:1000	A3	LENGTHS ARE IN METRES					

REF. 2004-R178

Published with the authority of the Coliban Region Water Corporation.

For and on behalf of the Coliban Region Water Corporation

Signed Andrew Cooney

Name ANDREW COONEY
 Corporate Secretary

Dated 3 January 2013

Land Acquisition and Compensation Act 1986

FORM 7

S. 21(a)
Reg. 16

Notice of Acquisition

Compulsory Acquisition of Interest in Land

The Coliban Region Water Corporation (ABN 96 549 082 363), of 37–45 Bridge Street, Bendigo 3550, declares that by this notice it acquires the following interest in the land described as Lot 1 on Title Plan 403111H, being more particularly contained within Certificate of Title Volume 8086 Folio 824:

An Easement for a Pipeline for Water Supply purposes over that part of the land shown as ‘E-1’ on the Plan of Creation of Easement (Ref 2004-R182), which is annexed hereto.

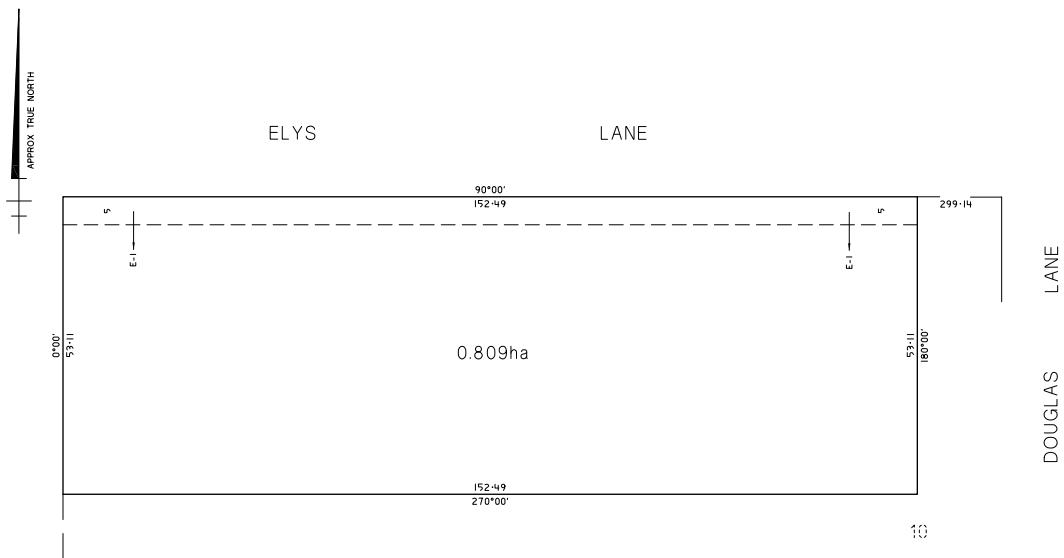

ORIGINAL		SCALE					
SCALE	SHEET SIZE	5	0	5	10	15	20
1:500	A3	1	1	1	1	1	1

LENGTHS ARE IN METRES REF. 2004-R182

Published with the authority of the Coliban Region Water Corporation.
 For and on behalf of the Coliban Region Water Corporation
 Signed Andrew Cooney
 Name ANDREW COONEY
 Corporate Secretary
 Dated 3 January 2013

Land Acquisition and Compensation Act 1986

FORM 7

S. 21(a)
Reg. 16

Notice of Acquisition

Compulsory Acquisition of Interest in Land

The Coliban Region Water Corporation (ABN 96 549 082 363), of 37–45 Bridge Street, Bendigo 3550, declares that by this notice it acquires the following interest in the land described as Lot 2 on Plan of Subdivision 546403G, being more particularly contained within Certificate of Title Volume 10990 Folio 115:

An Easement for a Pipeline for Water Supply purposes over that part of the land shown as 'E-2' on the Plan of Creation of Easement (Ref 2004-R184), which is annexed hereto.



ORIGINAL		SCALE					
SCALE	SHEET SIZE	12.5	0	12.5	25	37.5	50
1:1250	A3	LENGTHS ARE IN METRES					REF. 2004-R184

Published with the authority of the Coliban Region Water Corporation.

For and on behalf of the Coliban Region Water Corporation

Signed Andrew Cooney
Name ANDREW COONEY
Corporate Secretary

Dated 3 January 2013

Land Acquisition and Compensation Act 1986

FORM 7

S. 21(a)
Reg. 16

Notice of Acquisition

Compulsory Acquisition of Interest in Land

The Coliban Region Water Corporation (ABN 96 549 082 363), of 37–45 Bridge Street, Bendigo 3550, declares that by this notice it acquires the following interest in the land described as Lot 1 on Plan of Subdivision 546403G, being more particularly contained within Certificate of Title Volume 10990 Folio 114:

An Easement for a Pipeline for Water Supply purposes over that part of the land shown as ‘E-1’ on the Plan of Creation of Easement (Ref 2004-R185), which is annexed hereto.

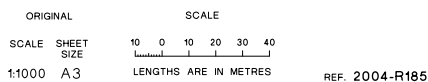
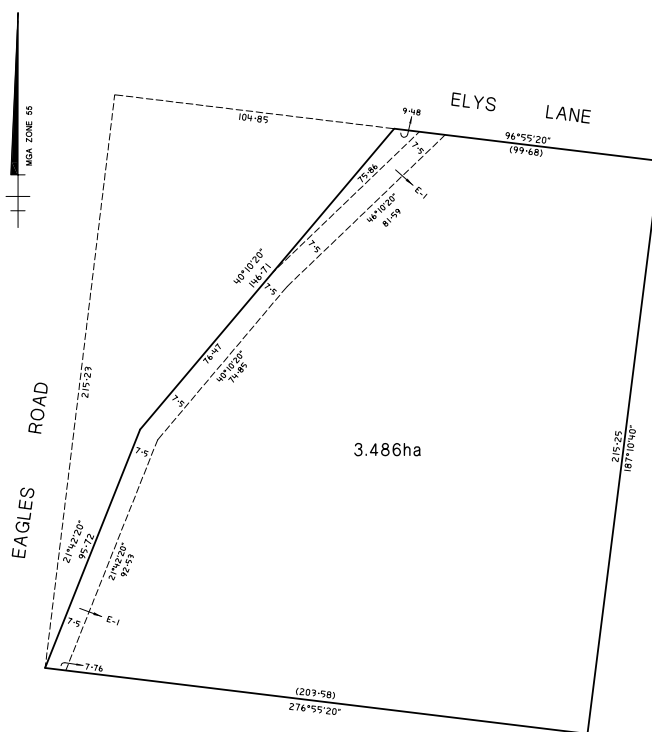

Published with the authority of the Coliban Region Water Corporation.
For and on behalf of the Coliban Region Water Corporation
Signed Andrew Cooney
Name ANDREW COONEY
Corporate Secretary
Dated 3 January 2013

Land Acquisition and Compensation Act 1986

FORM 7

S. 21(a)
Reg. 16

Notice of Acquisition

Compulsory Acquisition of Interest in Land

The Coliban Region Water Corporation (ABN 96 549 082 363), of 37–45 Bridge Street, Bendigo 3550, declares that by this notice it acquires the following interest in the land described as Lot 1 on Title Plan 535652H, being more particularly contained within Certificate of Title Volume 7428 Folio 412:

An Easement for a Pipeline for Water Supply purposes over that part of the land shown as ‘E-1’ on the Plan of Creation of Easement (Ref 2004-R190), which is annexed hereto.

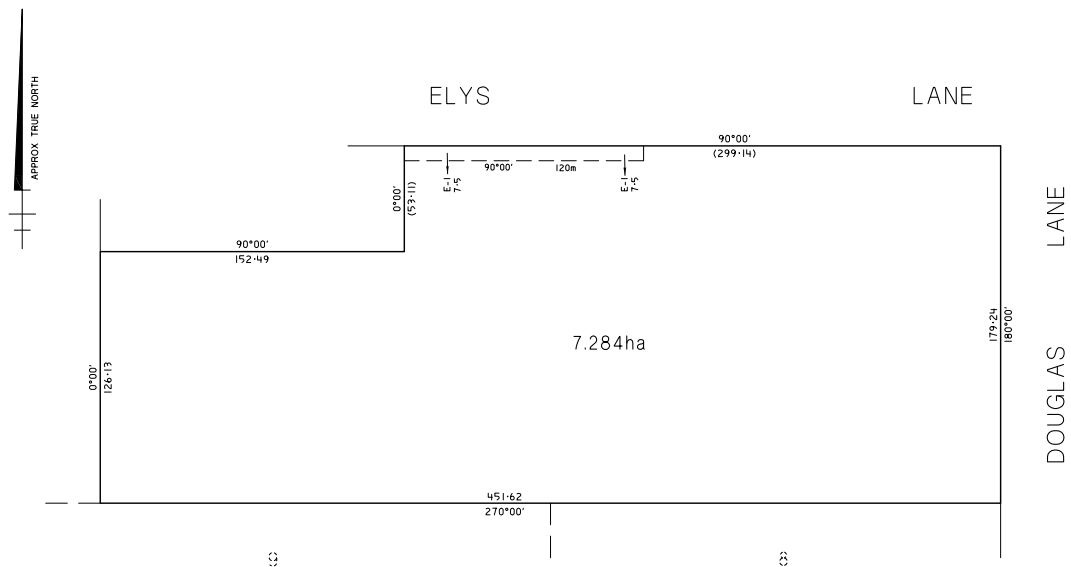

ORIGINAL		SCALE					
SCALE	SHEET SIZE	15	0	15	30	45	60
1:1500	A3	1	1	1	1	1	1
LENGTHS ARE IN METRES							

REF. 2004-R190

Published with the authority of the Coliban Region Water Corporation.
For and on behalf of the Coliban Region Water Corporation
Signed Andrew Cooney
Name ANDREW COONEY
Corporate Secretary
Dated 3 January 2013

Land Acquisition and Compensation Act 1986

FORM 7

S. 21(a)
Reg. 16

Notice of Acquisition

Compulsory Acquisition of Interest in Land

The Coliban Region Water Corporation (ABN 96 549 082 363), of 37–45 Bridge Street, Bendigo 3550, declares that by this notice it acquires the following interest in the land described as Crown Allotment 16 Section 5A Township of Harcourt Parish of Harcourt, being more particularly contained within Certificate of Title Volume 9868 Folio 727:

An Easement for a Pipeline for Water Supply purposes over that part of the land shown as ‘E-1’ on the Plan of Creation of Easement (Ref 2004-R191), which is annexed hereto.

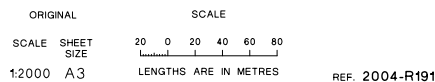
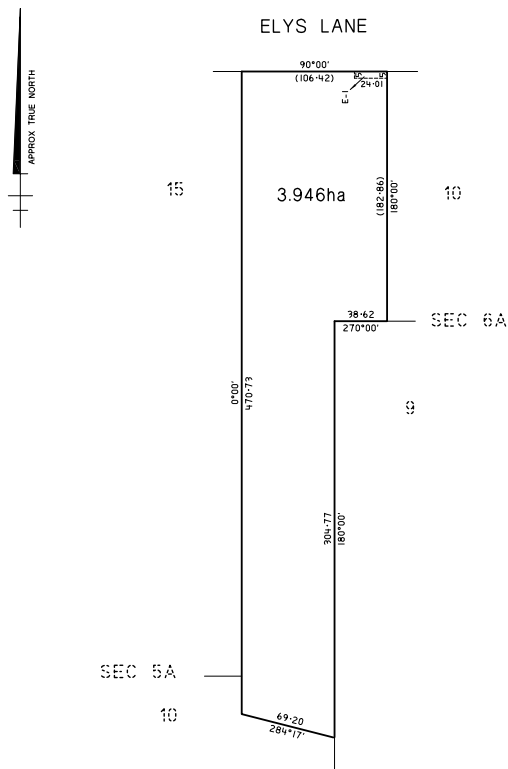

Published with the authority of the Coliban Region Water Corporation.
 For and on behalf of the Coliban Region Water Corporation
 Signed Andrew Cooney
 Name ANDREW COONEY
 Corporate Secretary
 Dated 3 January 2013

Land Acquisition and Compensation Act 1986

FORM 7

S. 21(a)
Reg. 16

Notice of Acquisition

Compulsory Acquisition of Interest in Land

The Coliban Region Water Corporation (ABN 96 549 082 363), of 37–45 Bridge Street, Bendigo 3550, declares that by this notice it acquires the following interest in the land described as Crown Allotments 10 and 15 Section 4 Parish of Harcourt, being more particularly contained within Certificate of Title Volume 7991 Folio 154:

An Easement for a Pipeline for Water Supply purposes over that part of the land shown as 'E-1' on the Plan of Creation of Easement (Ref 2004-R203), which is annexed hereto.

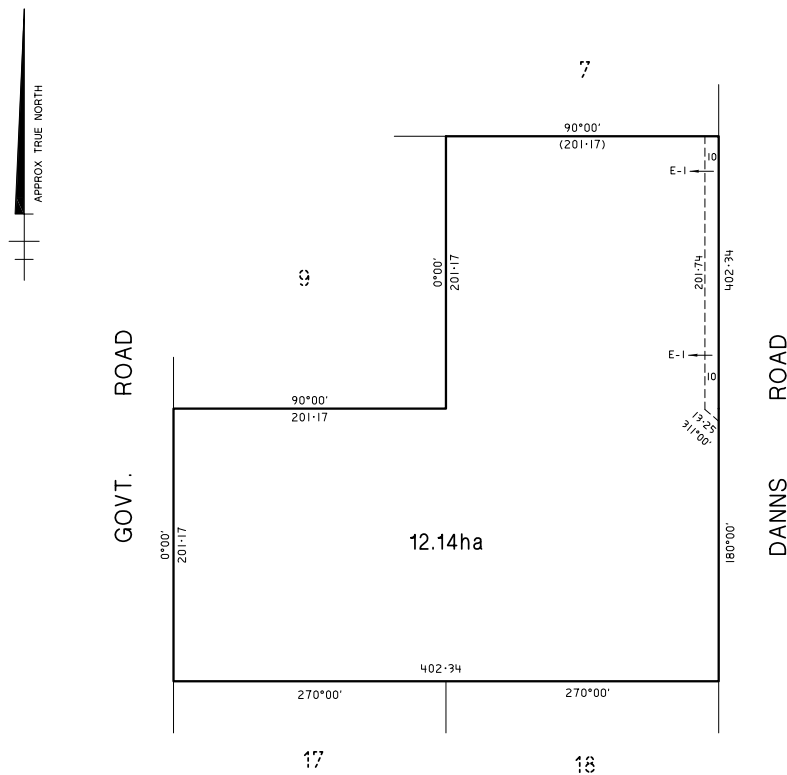

ORIGINAL SCALE
 SCALE SHEET SIZE 25 0 25 50 75 100
 1:2500 A3 LENGTHS ARE IN METRES REF. 2004-R203

Published with the authority of the Coliban Region Water Corporation.

For and on behalf of the Coliban Region Water Corporation

Signed Andrew Cooney
 Name ANDREW COONEY
 Corporate Secretary

Dated 3 January 2013

Land Acquisition and Compensation Act 1986

FORM 7

S. 21(a)
Reg. 16

Notice of Acquisition

Compulsory Acquisition of Interest in Land

The Coliban Region Water Corporation (ABN 96 549 082 363), of 37–45 Bridge Street, Bendigo 3550, declares that by this notice it acquires the following interest in the land described as Lot 1 on Plan of Subdivision 116577 and Lot 2 on Title Plan 245603N, being more particularly contained within Certificates of Title Volume 9162 Folio 229 and Volume 8230 Folio 074:

An Easement for a Pipeline for Water Supply purposes over that part of the land shown as 'E-1' on the Plans of Creation of Easement (Ref 2004-R206 and 2004-R207), which are annexed hereto.

MILLS ROAD

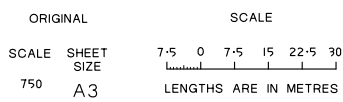
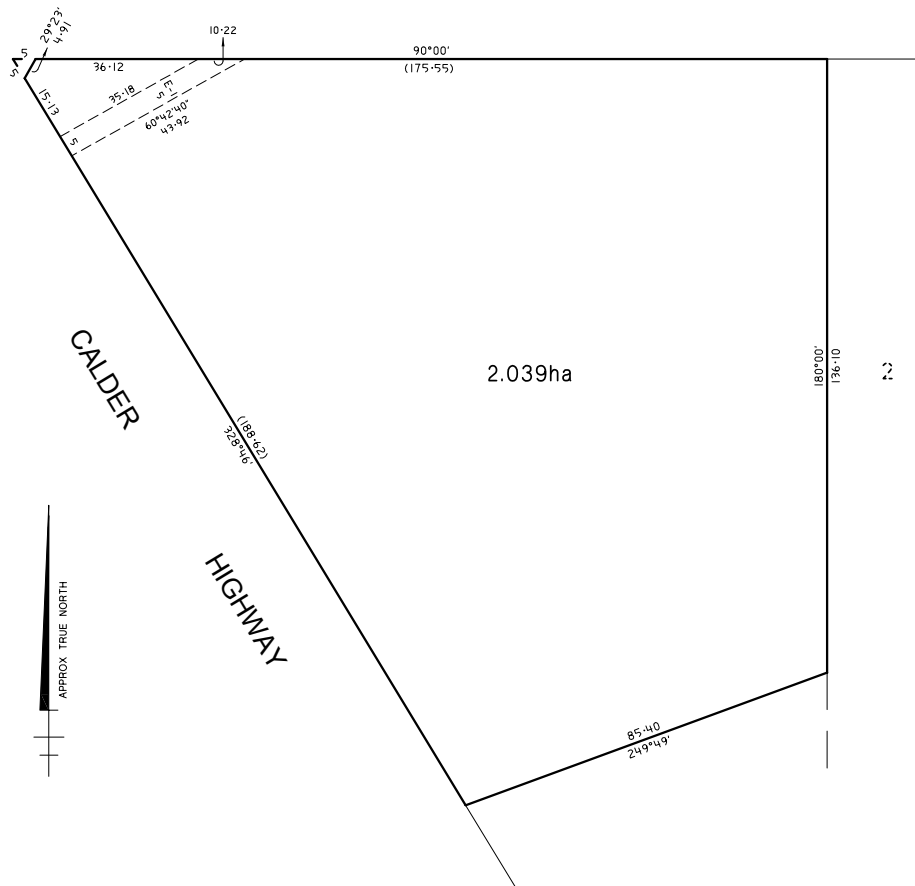

REF. 2004-R206

Land Acquisition and Compensation Act 1986

FORM 7

S. 21(a)
Reg. 16

Notice of Acquisition

Compulsory Acquisition of Interest in Land

The Coliban Region Water Corporation (ABN 96 549 082 363), of 37–45 Bridge Street, Bendigo 3550, declares that by this notice it acquires the following interest in the land described as Crown Allotments 27 and 29 Section 4 Parish of Harcourt, being more particularly contained within Conveyance No. 819 Book 774:

An Easement for a Pipeline for Water Supply purposes over that part of the land shown as 'E-1' on the Plan of Creation of Easement (Ref 2004-R209), which is annexed hereto.

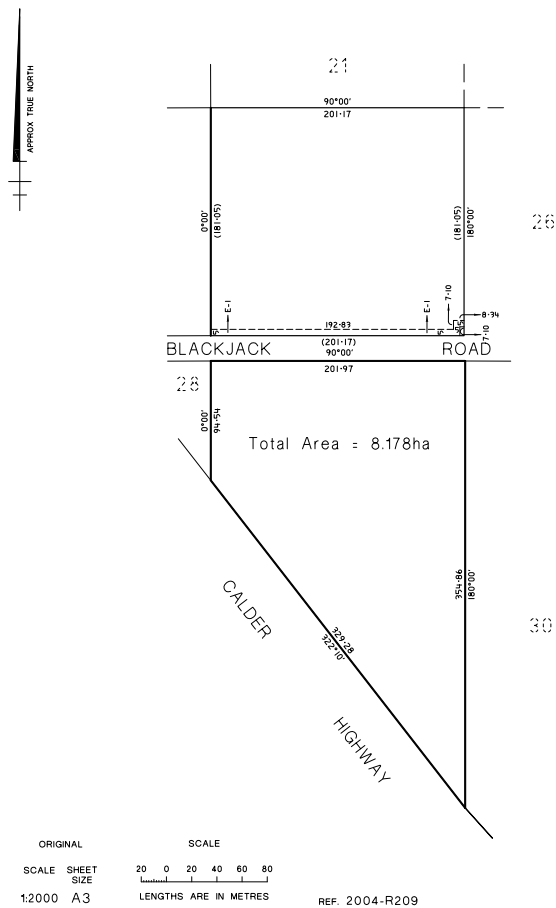

Published with the authority of the Coliban Region Water Corporation.
 For and on behalf of the Coliban Region Water Corporation
 Signed Andrew Cooney
 Name ANDREW COONEY
 Corporate Secretary
 Dated 3 January 2013

Land Acquisition and Compensation Act 1986

FORM 7

S. 21(a)
Reg. 16

Notice of Acquisition

Compulsory Acquisition of Interest in Land

The Coliban Region Water Corporation (ABN 96 549 082 363), of 37-45 Bridge Street, Bendigo 3550, declares that by this notice it acquires the following interest in the land described as Lot 2 on Plan of Subdivision 320360J, being more particularly contained within Certificate of Title Volume 10091 Folio 832:

An Easement for a Pipeline for Water Supply purposes over that part of the land shown as 'E-1' on the Plan of Creation of Easement (Ref 2004-R268), which is annexed hereto.

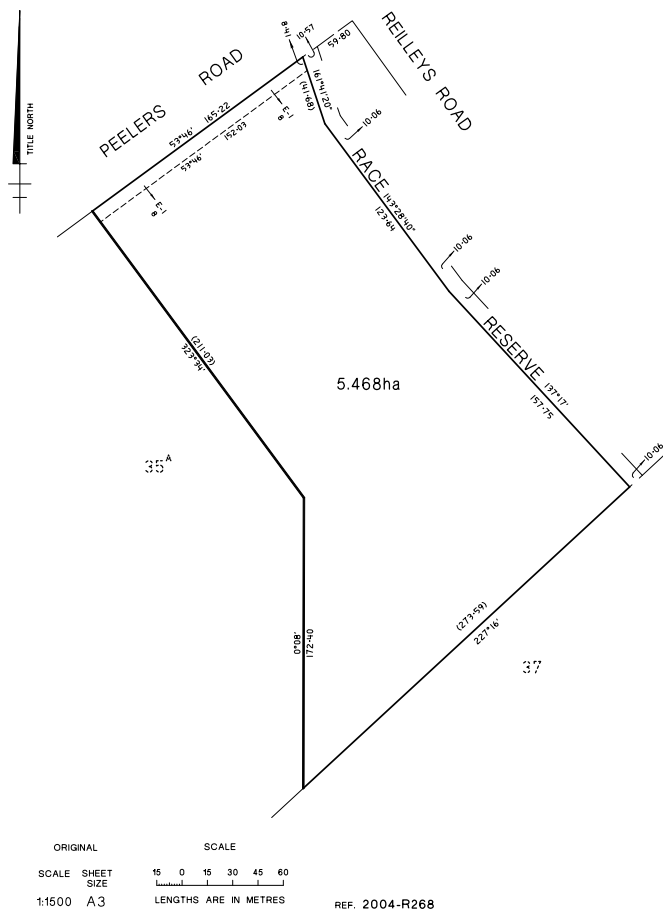

Published with the authority of the Coliban Region Water Corporation.

For and on behalf of the Coliban Region Water Corporation

Signed Andrew Cooney
Name ANDREW COONEY
Corporate Secretary

Dated 3 January 2013

Land Acquisition and Compensation Act 1986

FORM 7

S. 21(a)
Reg. 16

Notice of Acquisition

Compulsory Acquisition of Interest in Land

The Coliban Region Water Corporation (ABN 96 549 082 363), of 37-45 Bridge Street, Bendigo 3550, declares that by this notice it acquires the following interest in the land described as Lot 1 on Plan of Subdivision 136828, being more particularly contained within Certificate of Title Volume 9450 Folio 407:

An Easement for a Pipeline for Water Supply purposes over that part of the land shown as 'E-1' on the Plan of Creation of Easement (Ref 2004-R305), which is annexed hereto.

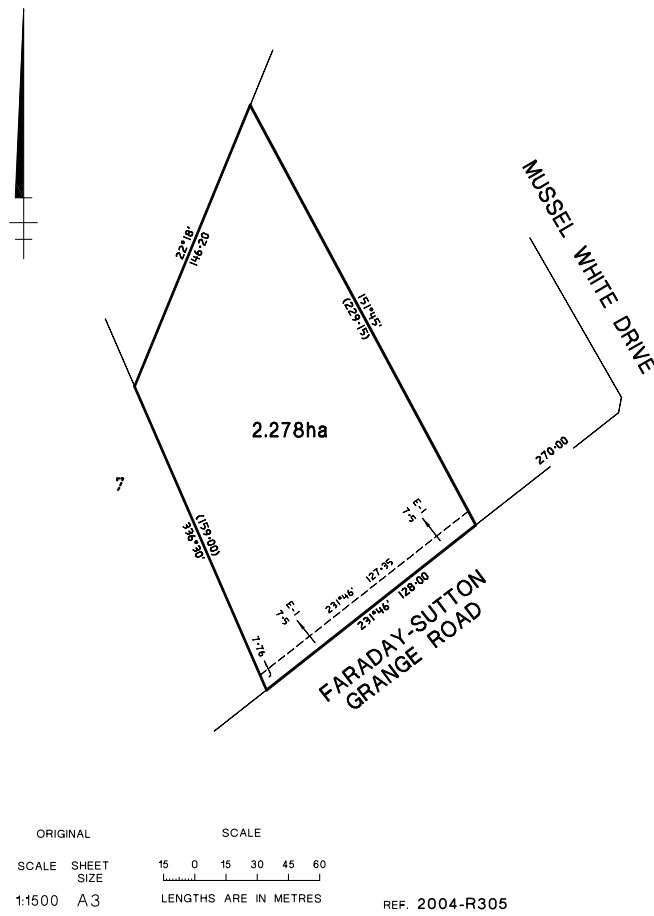

Published with the authority of the Coliban Region Water Corporation.
 For and on behalf of the Coliban Region Water Corporation
 Signed Andrew Cooney
 Name ANDREW COONEY
 Corporate Secretary
 Dated 3 January 2013

Land Acquisition and Compensation Act 1986

FORM 7

S. 21(a)
Reg. 16

Notice of Acquisition

Compulsory Acquisition of Interest in Land

The Coliban Region Water Corporation (ABN 96 549 082 363), of 37–45 Bridge Street, Bendigo 3550, declares that by this notice it acquires the following interest in the land described as Lot 2 on Plan of Subdivision 136828, being more particularly contained within Certificate of Title Volume 9450 Folio 408:

An Easement for a Pipeline for Water Supply purposes over that part of the land shown as ‘E-1’ on the Plan of Creation of Easement (Ref 2004-R306), which is annexed hereto.

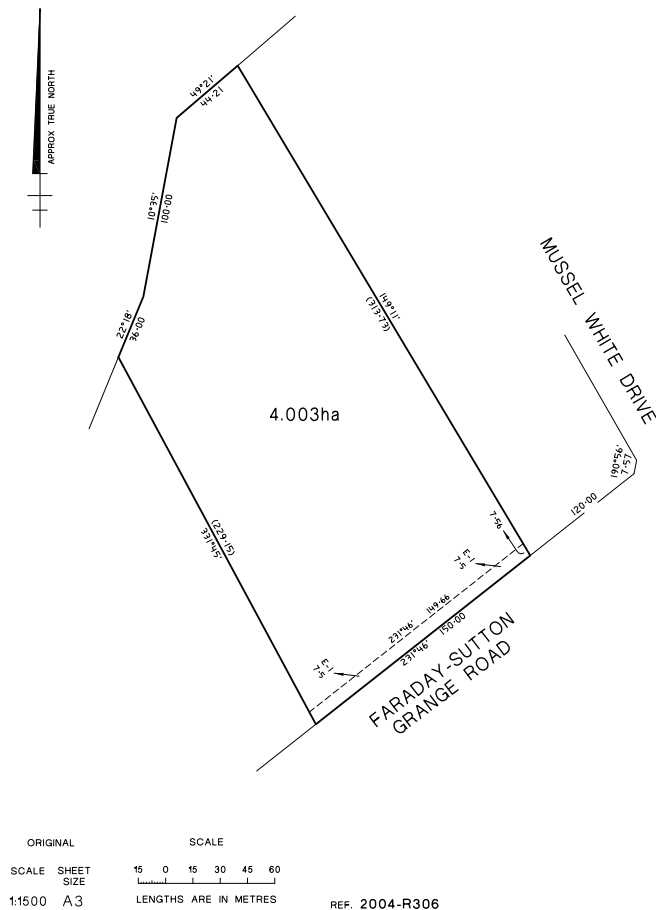

Published with the authority of the Coliban Region Water Corporation.
 For and on behalf of the Coliban Region Water Corporation
 Signed Andrew Cooney
 Name ANDREW COONEY
 Corporate Secretary
 Dated 3 January 2013

Land Acquisition and Compensation Act 1986

FORM 7

S. 21(a)
Reg. 16

Notice of Acquisition

Compulsory Acquisition of Interest in Land

The Coliban Region Water Corporation (ABN 96 549 082 363), of 37-45 Bridge Street, Bendigo 3550, declares that by this notice it acquires the following interest in the land described as Lot 3 on Plan of Subdivision 136828, being more particularly contained within Certificate of Title Volume 9450 Folio 409:

An Easement for a Pipeline for Water Supply purposes over that part of the land shown as 'E-1' on the Plan of Creation of Easement (Ref 2004-R307), which is annexed hereto.

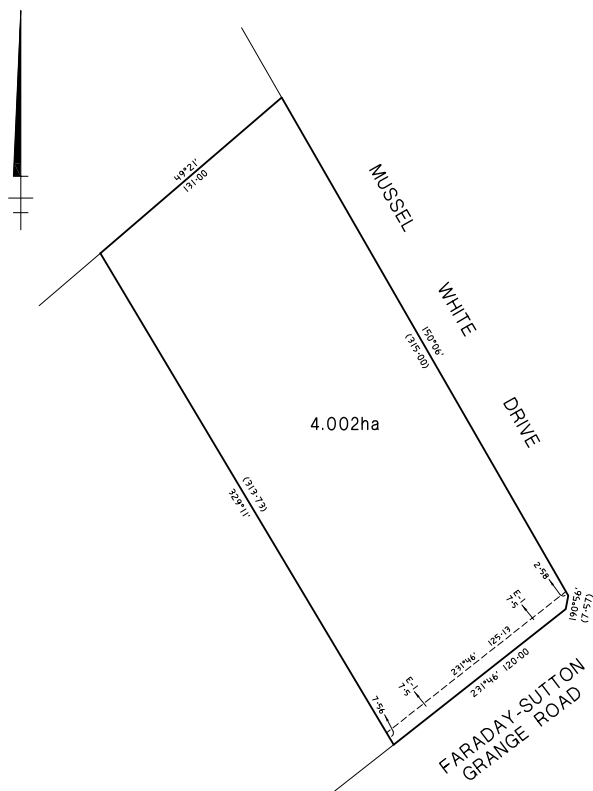

ORIGINAL SCALE
SCALE SHEET 15 0 15 30 45 60
SIZE 1:1500 A3 LENGTHS ARE IN METRES REF. 2004-R307

Published with the authority of the Coliban Region Water Corporation.

For and on behalf of the Coliban Region Water Corporation

Signed Andrew Cooney
Name ANDREW COONEY
Corporate Secretary

Dated 3 January 2013

Land Acquisition and Compensation Act 1986**FORM 7**S. 21(a)
Reg. 16

Notice of Acquisition

Compulsory Acquisition of Interest in Land

The Coliban Region Water Corporation (ABN 96 549 082 363), of 37–45 Bridge Street, Bendigo 3550, declares that by this notice it acquires the following interest in the land described as Crown Allotment 17 Section 4 Parish of Faraday, being more particularly contained within Certificate of Title Volume 10006 Folio 059:

An Easement for a Pipeline for Water Supply purposes over that part of the land shown as 'E-1' on the Plan of Creation of Easement (Ref 2004-R309), which is annexed hereto.

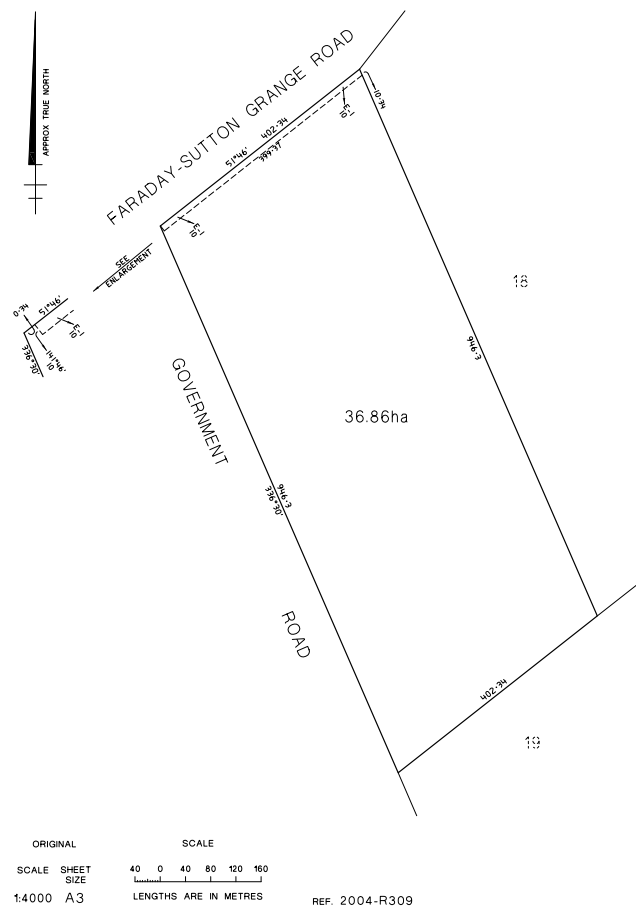

Published with the authority of the Coliban Region Water Corporation.

For and on behalf of the Coliban Region Water Corporation

Signed Andrew Cooney

Name ANDREW COONEY
Corporate Secretary

Dated 3 January 2013

Land Acquisition and Compensation Act 1986
FORM 7

S. 21(a)
 Reg. 16

Notice of Acquisition

Compulsory Acquisition of Interest in Land

The Coliban Region Water Corporation (ABN 96 549 082 363), of 37–45 Bridge Street, Bendigo 3550, declares that by this notice it acquires the following interest in the land described as Crown Allotment 8 Section 2 Parish of Harcourt and described in Title Plan No. TP9735P, being more particularly contained within Conveyance No. 485 Book 726:

An Easement for a Pipeline for Water Supply purposes over that part of the land shown as 'E-1' on the Plan of Creation of Easement (Ref 2004-R373), which is annexed hereto.

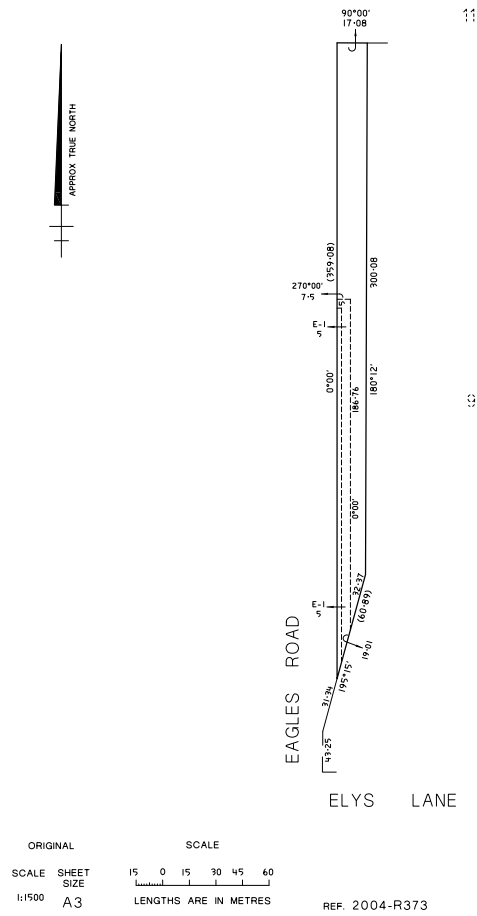

Published with the authority of the Coliban Region Water Corporation.
 For and on behalf of the Coliban Region Water Corporation
 Signed Andrew Cooney
 Name ANDREW COONEY
 Corporate Secretary
 Dated 3 January 2013

Land Acquisition and Compensation Act 1986

FORM 7

S. 21(a)
Reg. 16

Notice of Acquisition

Compulsory Acquisition of Interest in Land

The Coliban Region Water Corporation (ABN 96 549 082 363), of 37–45 Bridge Street, Bendigo 3550, declares that by this notice it acquires the following interest in the land described as Crown Allotment 9 Section 2 Parish of Harcourt and Lot 1 on Title Plan 9735P, being more particularly contained within Certificates of Title Volume 9609 Folio 553 and Volume 10368 Folio 873:

An Easement for a Pipeline for Water Supply purposes over that part of the land shown as ‘E-1’ on the Plans of Creation of Easement (Ref 2004-R374 and 2004-R375), which are annexed hereto.

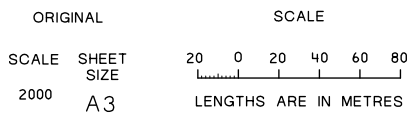
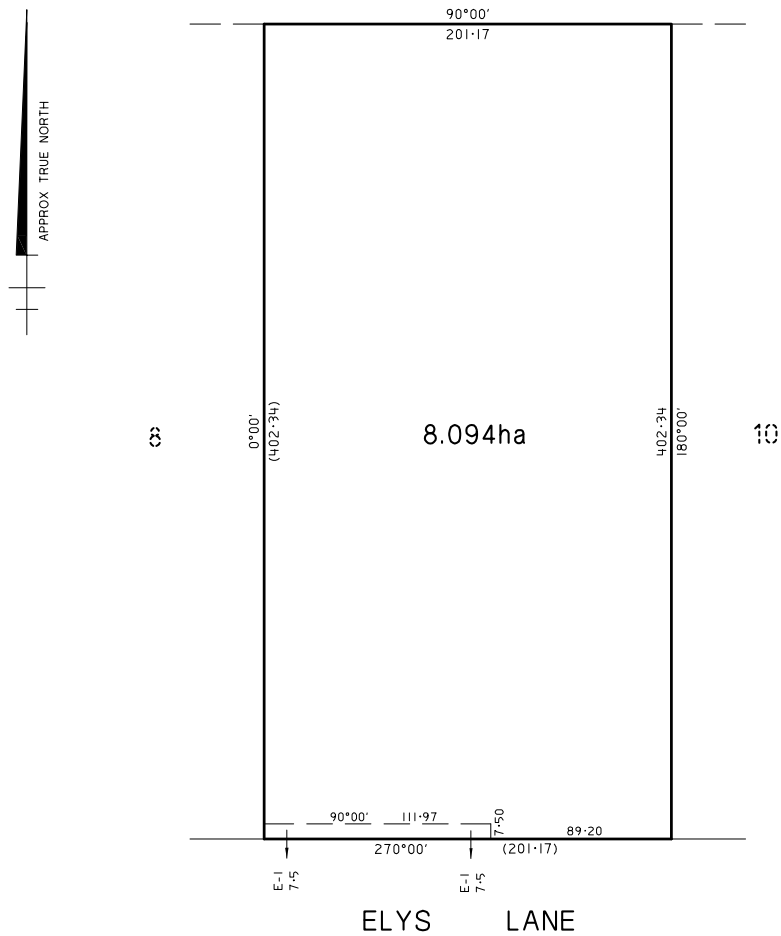

REF. 2004-R374

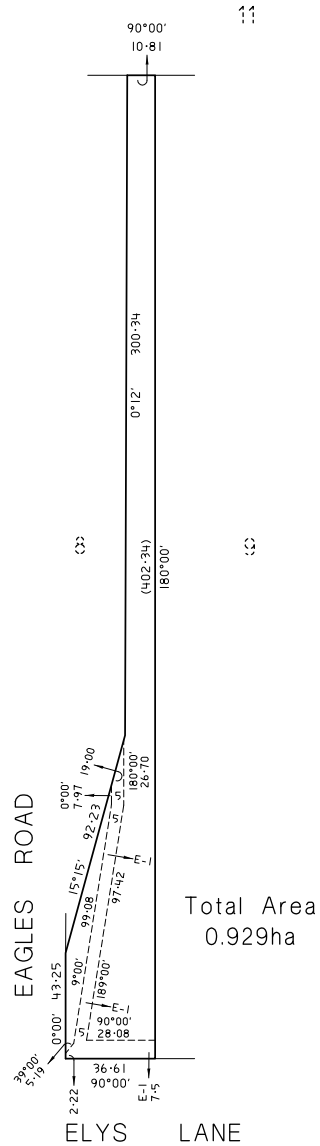

ORIGINAL SCALE SHEET SIZE 1:1500 A3

SCALE LENGTHS ARE IN METRES

15 0 15 30 45 60

REF. 2004-R375

Published with the authority of the Coliban Region Water Corporation.
 For and on behalf of the Coliban Region Water Corporation
 Signed Andrew Cooney
 Name ANDREW COONEY
 Corporate Secretary
 Dated 3 January 2013

Land Acquisition and Compensation Act 1986

FORM 7

S. 21(a)
Reg. 16

Notice of Acquisition

Compulsory Acquisition of Interest in Land

The Coliban Region Water Corporation (ABN 96 549 082 363), of 37–45 Bridge Street, Bendigo 3550, declares that by this notice it acquires the following interest in the land described as Lots 1 and 2 on Title Plan 537763M and Lot 1 on Title Plan 576001V, being more particularly contained within Certificates of Title Volume 7416 Folio 032 and Volume 6622 Folio 222:

An Easement for a Pipeline for Water Supply purposes over that part of the land shown as 'E-1' on the Plans of Creation of Easement (Ref 2004-R390 and 2004-R430), which are annexed hereto.

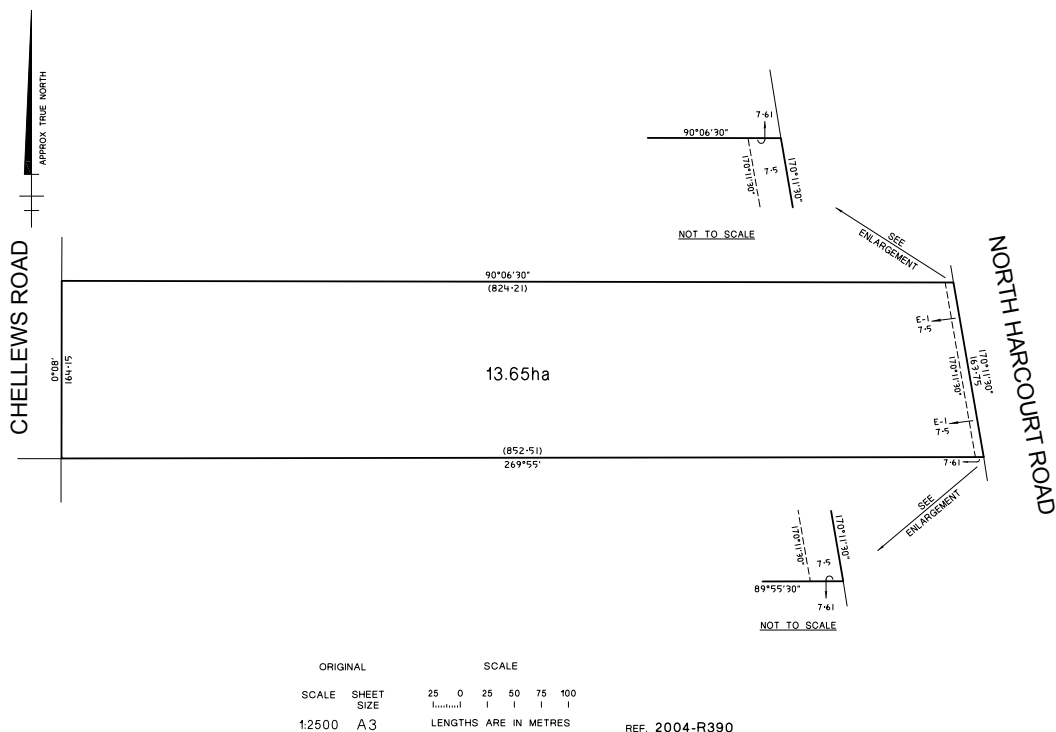

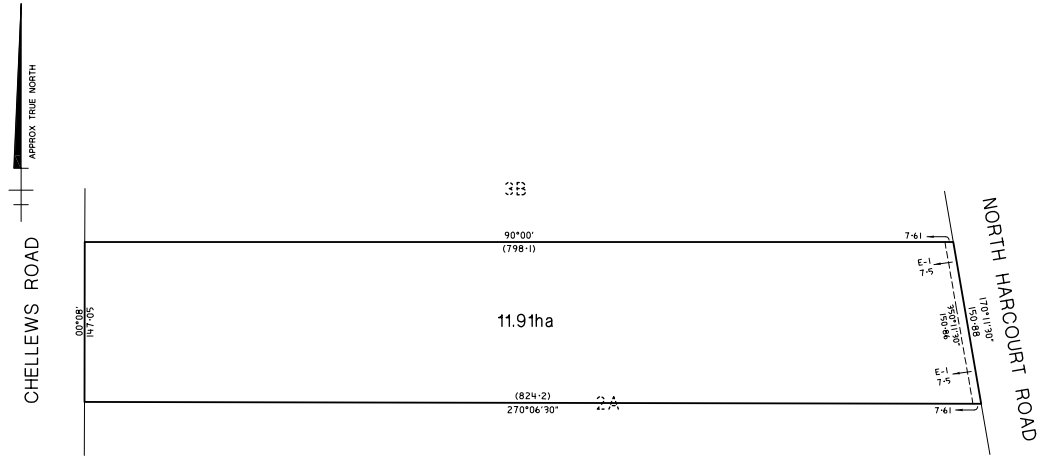

ORIGINAL		SCALE				REF. 2004-R430		
SCALE	SHEET SIZE	25	0	25	50		75	100
1:2500	A3	LENGTHS ARE IN METRES						

Published with the authority of the Coliban Region Water Corporation.
 For and on behalf of the Coliban Region Water Corporation
 Signed Andrew Cooney
 Name ANDREW COONEY
 Corporate Secretary
 Dated 3 January 2013

Land Acquisition and Compensation Act 1986

FORM 7

S. 21(a)
Reg. 16

Notice of Acquisition

Compulsory Acquisition of Interest in Land

The Coliban Region Water Corporation (ABN 96 549 082 363), of 37–45 Bridge Street, Bendigo 3550, declares that by this notice it acquires the following interest in the land described as Lot 13 on Plan of Subdivision 6496, being more particularly contained within Certificate of Title Volume 7782 Folio 005:

An Easement for a Pipeline for Water Supply purposes over that part of the land shown as ‘E-3’ on the Plan of Creation of Easement (Ref 2004-R393), which is annexed hereto.

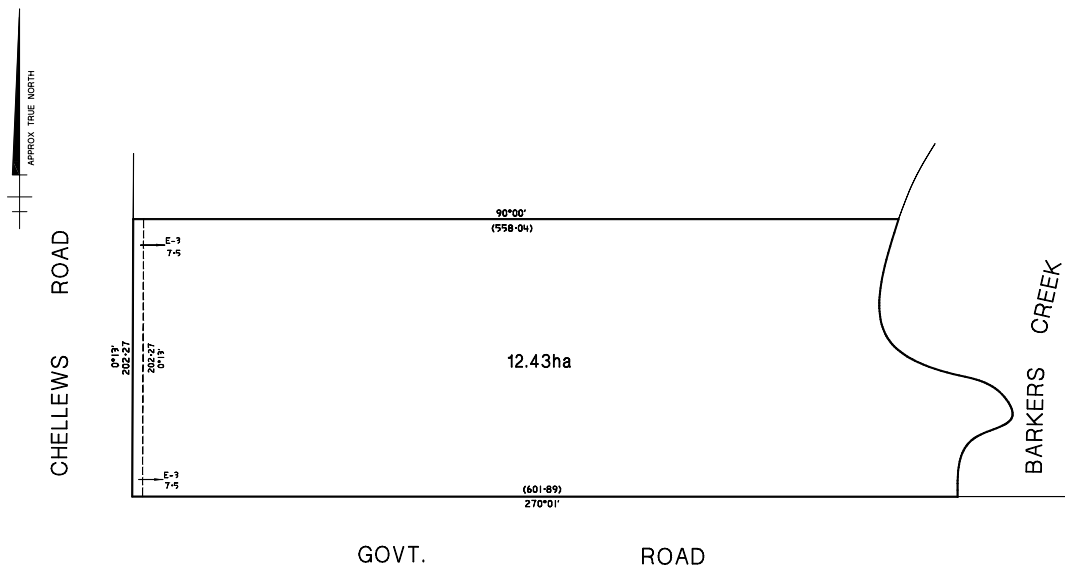

ORIGINAL		SCALE					
SCALE	SHEET SIZE	20	0	20	40	60	80
1:2000	A3	1	0	1	1	1	1
LENGTHS ARE IN METRES							

REF. 2004-R393

Published with the authority of the Coliban Region Water Corporation.

For and on behalf of the Coliban Region Water Corporation

Signed Andrew Cooney

Name ANDREW COONEY
Corporate Secretary

Dated 3 January 2013

Land Acquisition and Compensation Act 1986

FORM 7

S. 21(a)
Reg. 16

Notice of Acquisition

Compulsory Acquisition of Interest in Land

The Coliban Region Water Corporation (ABN 96 549 082 363), of 37–45 Bridge Street, Bendigo 3550, declares that by this notice it acquires the following interest in the land described as Crown Allotment 1A Section 6C Parish of Harcourt, being more particularly contained within Crown Grant Volume 8274 Folio 188:

An Easement for a Pipeline for Water Supply purposes over that part of the land shown as 'E-3' on the Plan of Creation of Easement (Ref 2004-R394), which is annexed hereto.

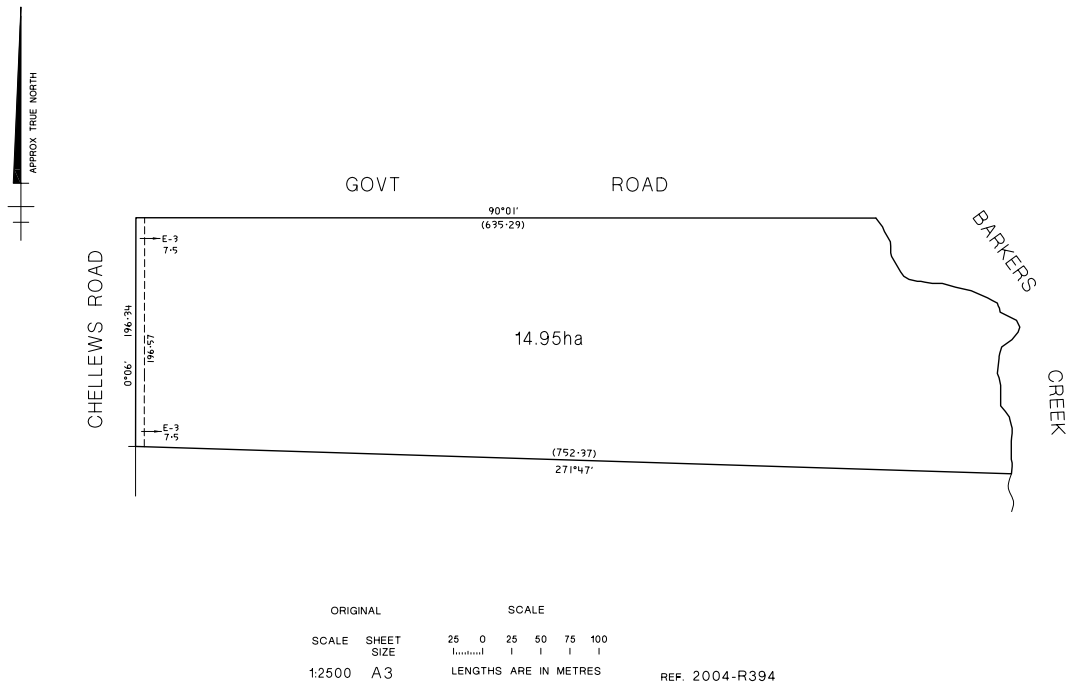

Published with the authority of the Coliban Region Water Corporation.

For and on behalf of the Coliban Region Water Corporation

Signed Andrew Cooney

Name ANDREW COONEY
Corporate Secretary

Dated 3 January 2013

Land Acquisition and Compensation Act 1986

FORM 7

S. 21(a)
Reg. 16

Notice of Acquisition

Compulsory Acquisition of Interest in Land

The Coliban Region Water Corporation (ABN 96 549 082 363), of 37–45 Bridge Street, Bendigo 3550, declares that by this notice it acquires the following interest in the land described as Lot 1 on Title Plan 257134F, being more particularly contained within Certificate of Title Volume 6999 Folio 691:

An Easement for a Pipeline for Water Supply purposes over that part of the land shown as ‘E-2’ on the Plan of Creation of Easement (Ref 2004-R397), which is annexed hereto.

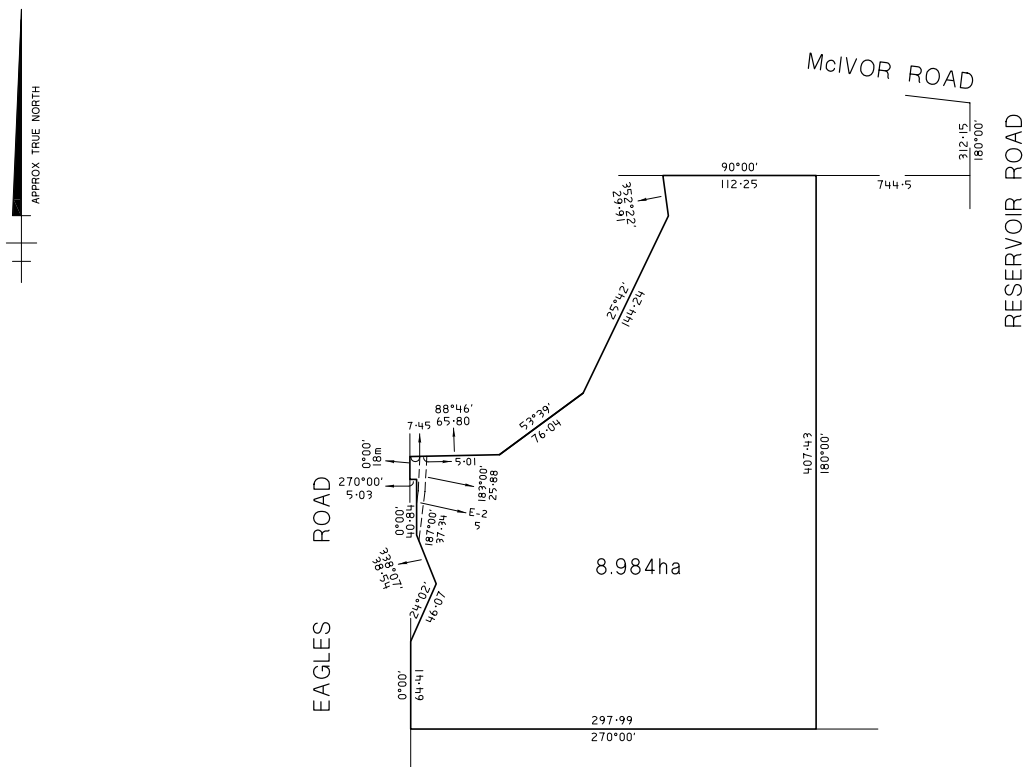

ORIGINAL	SCALE	
SCALE	SHEET SIZE	25 0 25 50 75 100
1:2500	A3	LENGTHS ARE IN METRES
		REF. 2004-R397

Published with the authority of the Coliban Region Water Corporation.
 For and on behalf of the Coliban Region Water Corporation
 Signed Andrew Cooney
 Name ANDREW COONEY
 Corporate Secretary
 Dated 3 January 2013

Land Acquisition and Compensation Act 1986

FORM 7

S. 21(a)
Reg. 16

Notice of Acquisition

Compulsory Acquisition of Interest in Land

The Coliban Region Water Corporation (ABN 96 549 082 363), of 37–45 Bridge Street, Bendigo 3550, declares that by this notice it acquires the following interest in the land described as Lot 7 on Plan of Subdivision 6496, being more particularly contained within Certificate of Title Volume 3848 Folio 566:

An Easement for a Pipeline for Water Supply purposes over that part of the land shown as 'E-3' on the Plan of Creation of Easement (Ref 2004-R399), which is annexed hereto.

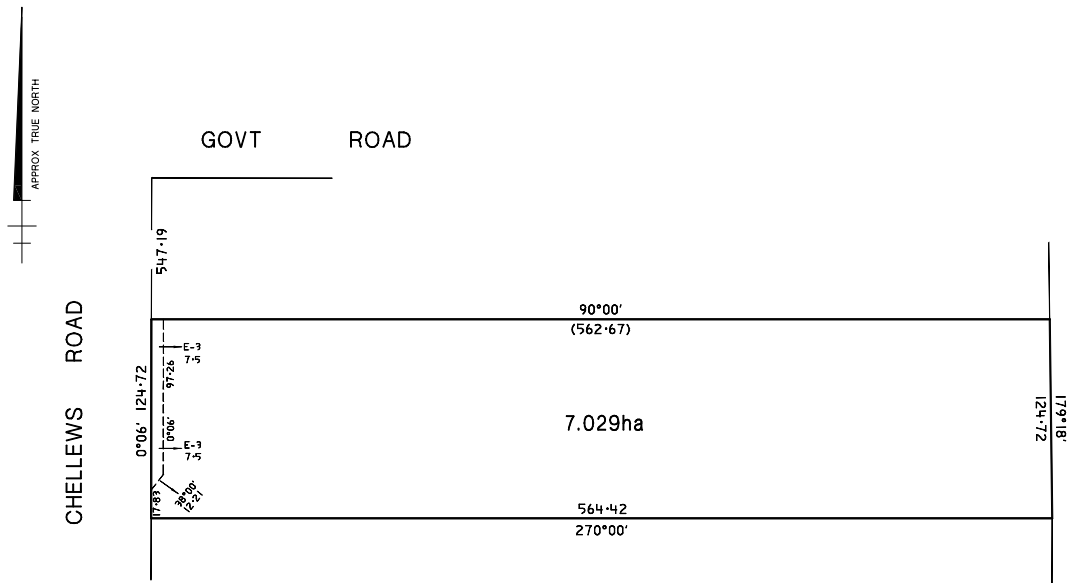

ORIGINAL		SCALE		
SCALE	SHEET SIZE	20	0	20
1:2000	A3	40	60	80
		LENGTHS ARE IN METRES		
				REF. 2004-R399

Published with the authority of the Coliban Region Water Corporation.

For and on behalf of the Coliban Region Water Corporation

Signed Andrew Cooney

Name ANDREW COONEY
Corporate Secretary

Dated 3 January 2013

Land Acquisition and Compensation Act 1986

FORM 7

S. 21(a)
Reg. 16

Notice of Acquisition

Compulsory Acquisition of Interest in Land

The Coliban Region Water Corporation (ABN 96 549 082 363), of 37-45 Bridge Street, Bendigo 3550, declares that by this notice it acquires the following interest in the land described as Crown Allotments 21 and 22 Section 5B Parish of Harcourt, being more particularly contained within Certificate of Title Volume 10116 Folio 395:

An Easement for a Pipeline for Water Supply purposes over that part of the land shown as 'E-1' on the Plan of Creation of Easement (Ref 2004-R406), which is annexed hereto.

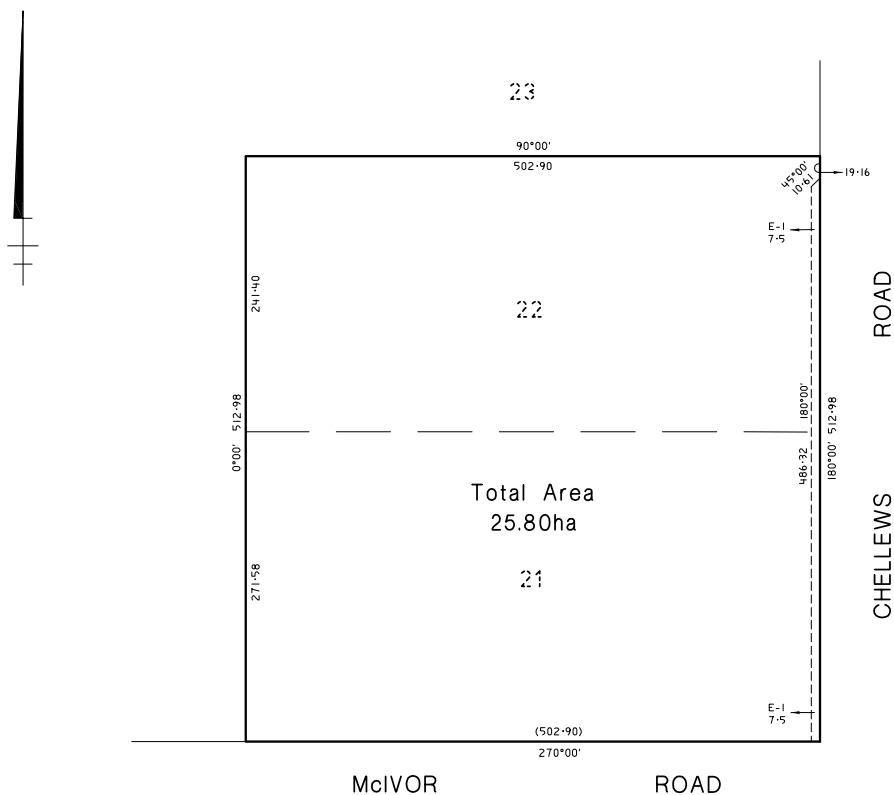

ORIGINAL	SCALE	
SCALE	SHEET SIZE	30 0 30 60 90 120
1:3000	A3	1 1 1 1 1
		LENGTHS ARE IN METRES
		REF. 2004-R406

Published with the authority of the Coliban Region Water Corporation.
 For and on behalf of the Coliban Region Water Corporation
 Signed Andrew Cooney
 Name ANDREW COONEY
 Corporate Secretary
 Dated 3 January 2013

Land Acquisition and Compensation Act 1986
FORM 7

S. 21(a)
 Reg. 16

Notice of Acquisition

Compulsory Acquisition of Interest in Land

The Coliban Region Water Corporation (ABN 96 549 082 363), of 37–45 Bridge Street, Bendigo 3550, declares that by this notice it acquires the following interest in the land described as Crown Allotment 23 Section 5B Parish of Harcourt, being more particularly contained within Certificate of Title Volume 3802 Folio 319:

An Easement for a Pipeline for Water Supply purposes over that part of the land shown as 'E-1' on the Plan of Creation of Easement (Ref 2004-R407), which is annexed hereto.

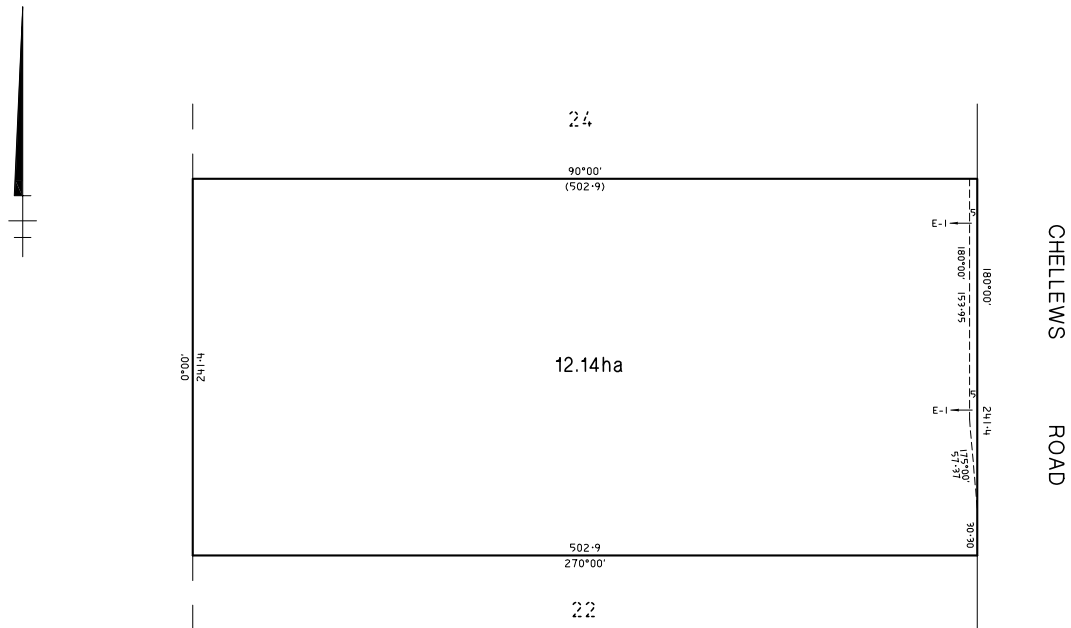

ORIGINAL	SCALE	
SCALE	SHEET SIZE	20 0 20 40 50 60
1:2000	A 3	LENGTHS ARE IN METRES

REF. 2004-R407

Published with the authority of the Coliban Region Water Corporation.

For and on behalf of the Coliban Region Water Corporation

Signed Andrew Cooney
 Name ANDREW COONEY
 Corporate Secretary

Dated 3 January 2013

Land Acquisition and Compensation Act 1986

FORM 7

S. 21(a)
Reg. 16

Notice of Acquisition

Compulsory Acquisition of Interest in Land

The Coliban Region Water Corporation (ABN 96 549 082 363), of 37–45 Bridge Street, Bendigo 3550, declares that by this notice it acquires the following interest in the land described as Lot 17 on Plan of Subdivision 6496, being more particularly contained within Certificate of Title Volume 8384 Folio 952:

An Easement for a Pipeline for Water Supply purposes over that part of the land shown as ‘E-2’ on the Plan of Creation of Easement (Ref 2004-R431), which is annexed hereto.

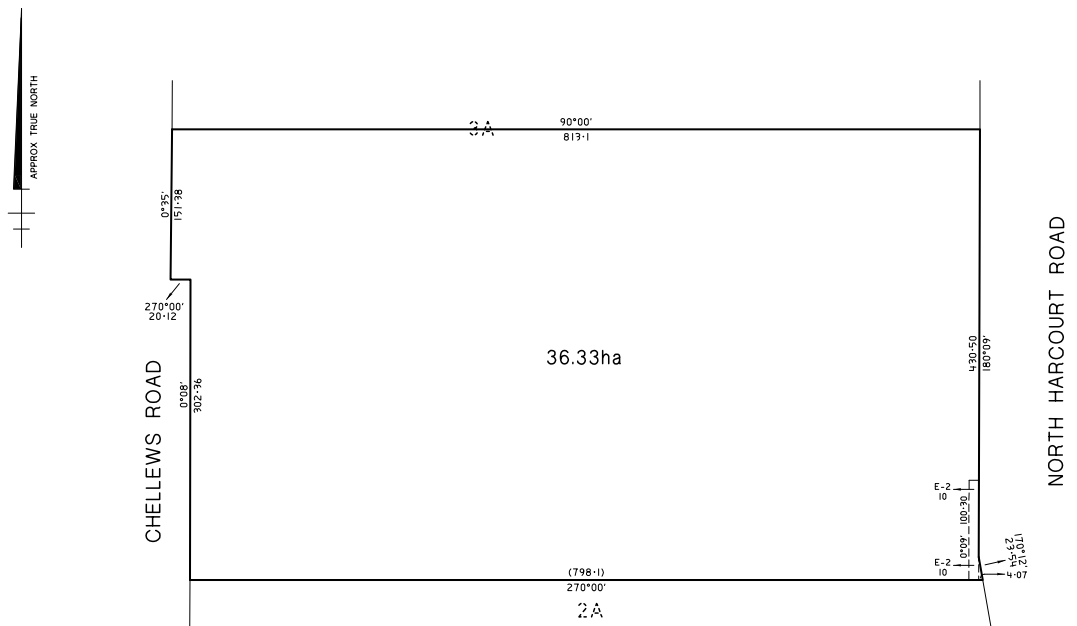

ORIGINAL		SCALE					
SCALE	SHEET SIZE	30	0	30	60	90	120
1:3000	A3	LENGTHS ARE IN METRES					
						REF. 2004-R431	

Published with the authority of the Coliban Region Water Corporation.
 For and on behalf of the Coliban Region Water Corporation
 Signed Andrew Cooney
 Name ANDREW COONEY
 Corporate Secretary
 Dated 3 January 2013

Land Acquisition and Compensation Act 1986

FORM 7

S. 21(a)
Reg. 16

Notice of Acquisition

Compulsory Acquisition of Interest in Land

The Coliban Region Water Corporation (ABN 96 549 082 363), of 37–45 Bridge Street, Bendigo 3550, declares that by this notice it acquires the following interest in the land described as Lot 1 on Title Plan 140583B, being more particularly contained within Certificate of Title Volume 9868 Folio 091:

An Easement for a Pipeline for Water Supply purposes over that part of the land shown as ‘E-1’ on the Plan of Creation of Easement (Ref 2004-R443), which is annexed hereto.

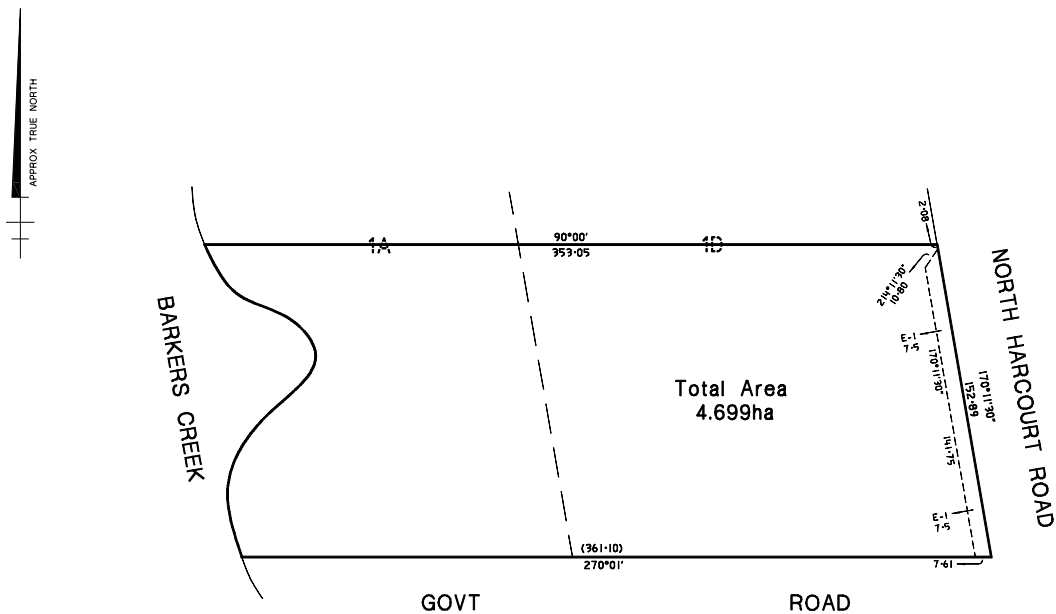

ORIGINAL		SCALE					
SCALE	SHEET SIZE	15	0	15	30	45	60
1:1500	A3	LENGTHS ARE IN METRES					
						REF. 2004-R443	

Published with the authority of the Coliban Region Water Corporation.
 For and on behalf of the Coliban Region Water Corporation
 Signed Andrew Cooney
 Name ANDREW COONEY
 Corporate Secretary
 Dated 3 January 2013

Land Acquisition and Compensation Act 1986

FORM 7

S. 21(a)
Reg. 16

Notice of Acquisition

Compulsory Acquisition of Interest in Land

The Coliban Region Water Corporation (ABN 96 549 082 363), of 37-45 Bridge Street, Bendigo 3550, declares that by this notice it acquires the following interest in the land described as Lots 3 and 4 on Title Plan 889222H, being more particularly contained within Certificate of Title Volume 7618 Folio 037:

An Easement for a Pipeline for Water Supply purposes over that part of the land shown as 'E-2' on the Plan of Creation of Easement (Ref 2004-R448), which is annexed hereto.

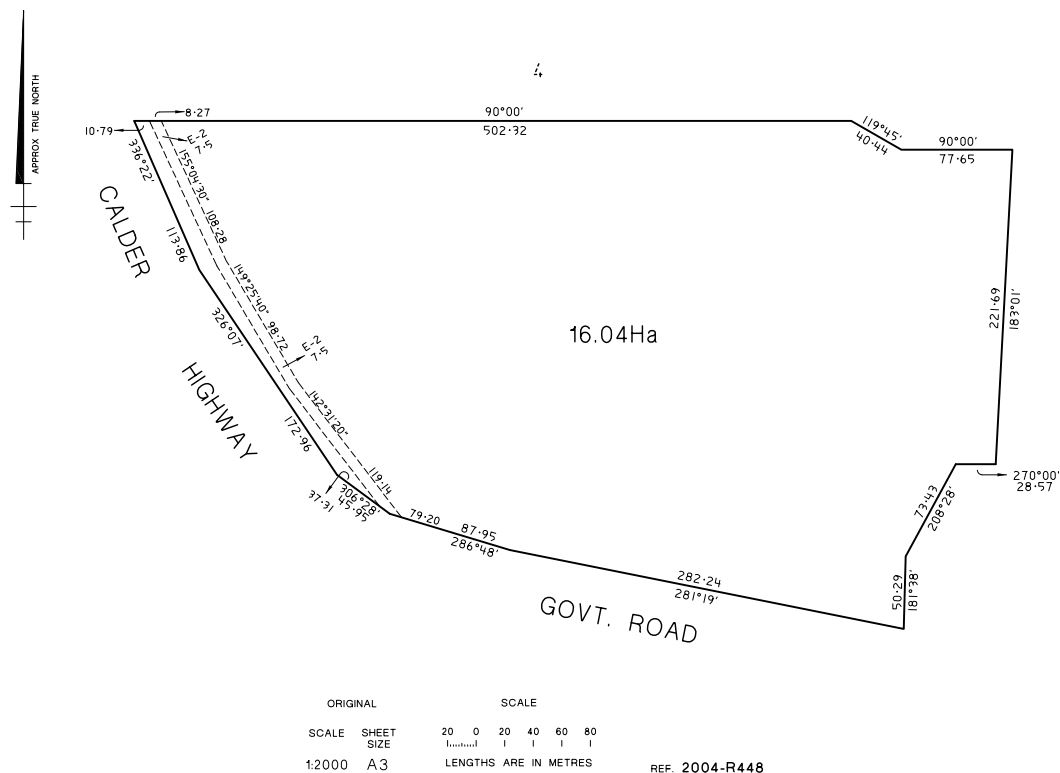

Published with the authority of the Coliban Region Water Corporation.

For and on behalf of the Coliban Region Water Corporation

Signed Andrew Cooney

Name ANDREW COONEY
Corporate Secretary

Dated 3 January 2013

Liquor Control Reform Act 1998**LIQUOR LICENSING POLL****Camberwell Neighbourhood**

The Victorian Commission for Gambling and Liquor Regulation (VCGLR) has received an application for a Restaurant and Café Licence for Sakura Inn, Shop GO3, 1101 Toorak Road, Camberwell. As the application for a licence is in a 'dry area', the VCGLR, pursuant to clause 17 of Schedule 3 of the **Liquor Control Reform Act 1998**, has ordered a poll of electors in the neighbourhood surrounding the above premises. The VCGLR determines this neighbourhood. The Victorian Electoral Commission (VEC) will conduct the poll entirely by post.

1. The neighbourhood indicated by the VCGLR

The Sakura Inn poll is within the following boundaries:

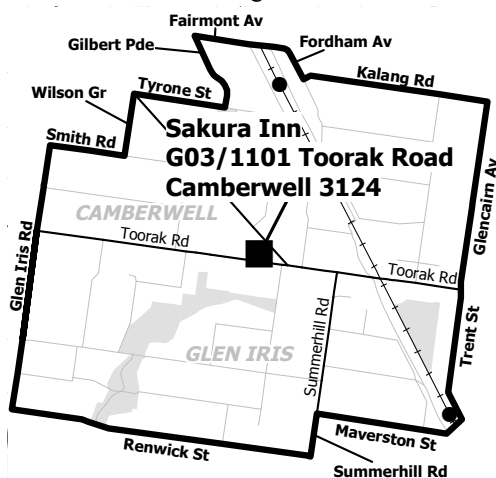

2. The resolution to be submitted to the electors
Electors in the licensing poll neighbourhood will be asked to vote 'yes' or 'no' with respect to the following resolution:
'That a Restaurant and Café Licence be granted in the neighbourhood of the premises situated at Shop GO3, 1101 Toorak Road, Camberwell'.
3. Persons entitled to vote in the poll
All electors who reside within the neighbourhood indicated, and who were enrolled on the electoral roll used for State elections at 5.00 pm on Thursday 6 December 2012, must vote in the poll.
Copies of the official roll for the poll may now be inspected at the Victorian Electoral Commission, Level 11, 530 Collins Street, Melbourne.
4. Voting is compulsory
Electors enrolled in the licensing poll neighbourhood at 5.00 pm on Thursday 6 December 2012, are obliged to vote. The penalty for failing to vote without a valid and sufficient reason is currently \$70.00.
5. Postal voting
The poll will be conducted entirely by post. Ballot papers will be mailed to all eligible electors on Thursday 10 January 2013. To be included in the count, completed ballot papers must be received by the VEC by 5.00 pm on Monday 4 February 2013.
6. Early voting
If you will be away when the ballot packs are mailed out, please call 131 832 to arrange an early postal vote.

PHILLIPPA HESKETT
Election Manager

This page was left blank intentionally

PRICING FOR SPECIAL GAZETTE, PERIODICAL GAZETTE AND VICTORIAN LEGISLATION

Retail price varies according to the number of pages in each Victoria Government Special Gazette, Victoria Government Periodical Gazette and Victorian legislation. The table below sets out the prices that apply.

<i>Price Code</i>	<i>No. of Pages (Including cover and blank pages)</i>	<i>Price*</i>	<i>Price Code</i>	<i>No. of Pages (Including cover and blank pages)</i>	<i>Price*</i>
A	1–16	\$3.90	#Z	1407–1470	\$116.50
B	17–32	\$5.85	#ZA	1471–1536	\$122.00
C	33–48	\$8.00	#ZB	1537–1610	\$126.70
D	49–96	\$12.60	#ZC	1611–1666	\$132.00
E	97–144	\$16.25	#ZD	1667–1730	\$137.00
F	145–192	\$19.25	#ZE	1731–1796	\$142.50
G	193–240	\$22.20	#ZF	1797–1860	\$147.65
H	241–288	\$23.60	#ZG	1861–1926	\$152.50
I	289–352	\$26.60	#ZH	1927–1990	\$158.00
J	353–416	\$31.00	#ZI	1991–2056	\$163.00
K	417–480	\$35.40			
L	481–544	\$41.30			
M	545–608	\$47.20			
N	609–672	\$52.20			
O	673–736	\$59.00			
P	737–820	\$65.00			
#Q	821–886	\$70.70			
#R	887–950	\$75.40			
#S	951–1016	\$80.50			
#T	1017–1080	\$85.50			
#U	1081–1146	\$90.65			
#V	1147–1210	\$96.00			
#W	1211–1276	\$101.00			
#X	1277–1340	\$106.45			
#Y	1341–1406	\$111.25			

* All prices include GST

Printed as two volumes

bluestar * **PRINT**

The *Victoria Government Gazette* is published by Blue Star Print with the authority of the Government Printer for the State of Victoria

© State of Victoria 2013

This publication is copyright. No part may be reproduced by any process except in accordance with the provisions of the Copyright Act.

Address all enquiries to the Government Printer for the State of Victoria
Level 2, 1 Macarthur Street
Melbourne 3002
Victoria Australia

How To Order**Mail Order****Victoria Government Gazette**

Level 5, 460 Bourke Street
Melbourne 3000
PO Box 1957 Melbourne 3001
DX 106 Melbourne

**Telephone**

(03) 8523 4601

**Fax**

(03) 9600 0478

email

gazette@bluestargroup.com.au

**Retail & Mail Sales****Victoria Government Gazette**

Level 5, 460 Bourke Street
Melbourne 3000
PO Box 1957 Melbourne 3001

**Telephone**

(03) 8523 4601

**Fax**

(03) 9600 0478

**Retail Sales****Victorian Government Bookshop**

Level 20, 80 Collins Street
Melbourne 3000

**Telephone**

1300 366 356

**Fax**

(03) 9208 3316

ISSN 0819-5471



9 770819 554766

Recommended Retail Price \$2.00 (includes GST)