



Victoria Government Gazette

No. S 7 Tuesday 8 January 2013
By Authority of Victorian Government Printer

Land Acquisition and Compensation Act 1986 FORM 7

S. 21(a)
Reg. 16

Notice of Acquisition

Compulsory Acquisition of Interest in Land

The Coliban Region Water Corporation (ABN 96 549 082 363), of 37–45 Bridge Street, Bendigo 3550, declares that by this notice it acquires the following interest in the land described as Lot 9 on Plan of Subdivision 522846E, being more particularly contained within Certificate of Title Volume 11004 Folio 796:

An Easement for a Pipeline for Water Supply purposes over that part of the land shown as 'E-1' on the Plan of Creation of Easement (Ref 2004-P075), which is annexed hereto.

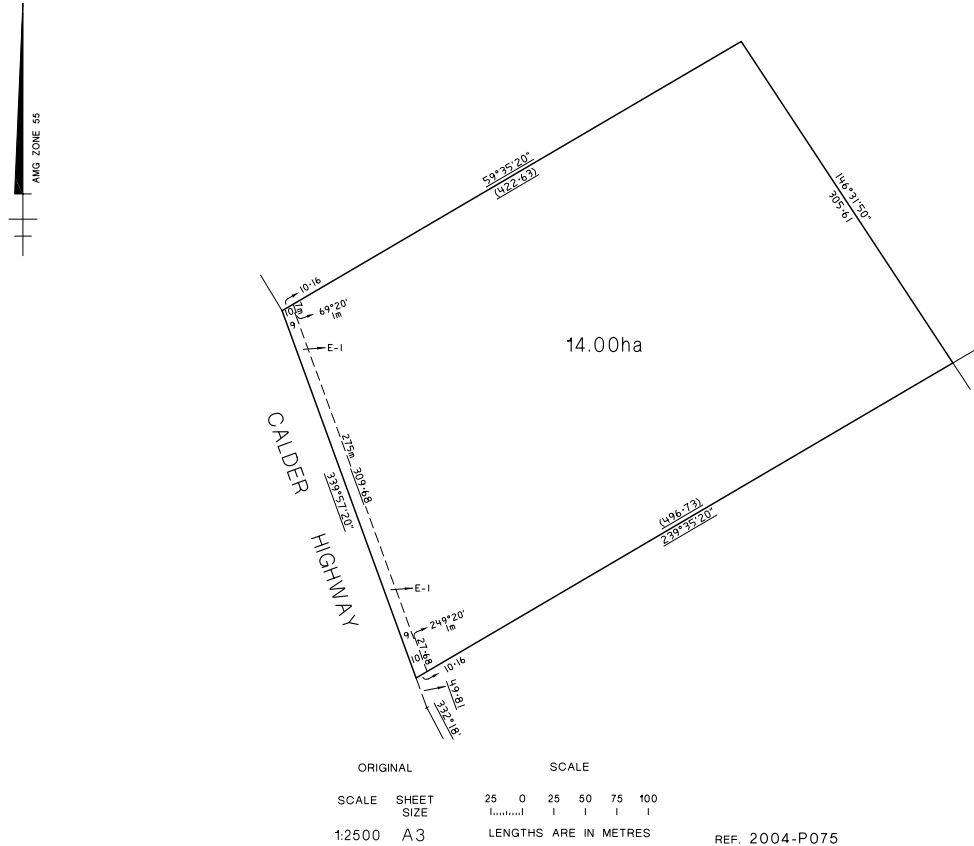

Published with the authority of the Coliban Region Water Corporation.
For and on behalf of the Coliban Region Water Corporation
Signed Andrew Cooney
Name ANDREW COONEY
Corporate Secretary
Dated 8 January 2013

SPECIAL

Land Acquisition and Compensation Act 1986

FORM 7

S. 21(a)
Reg. 16

Notice of Acquisition

Compulsory Acquisition of Interest in Land

The Coliban Region Water Corporation (ABN 96 549 082 363), of 37-45 Bridge Street, Bendigo 3550, declares that by this notice it acquires the following interest in the land described as Crown Allotments 10, 11 and 12 Parish of Faraday and Lot 1 on Title Plan 219692J, being more particularly contained within Certificates of Title Volume 10102 Folios 220, 221 and 222 and Volume 5342 Folio 358:

An Easement for a Pipeline for Water Supply purposes over that part of the land shown as 'E-1' on the Plans of Creation of Easement (Ref 2004-P142, 2004-P143, 2004-P144 and 2004-P167), which are annexed hereto.

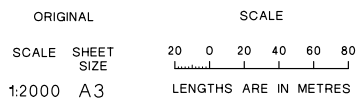
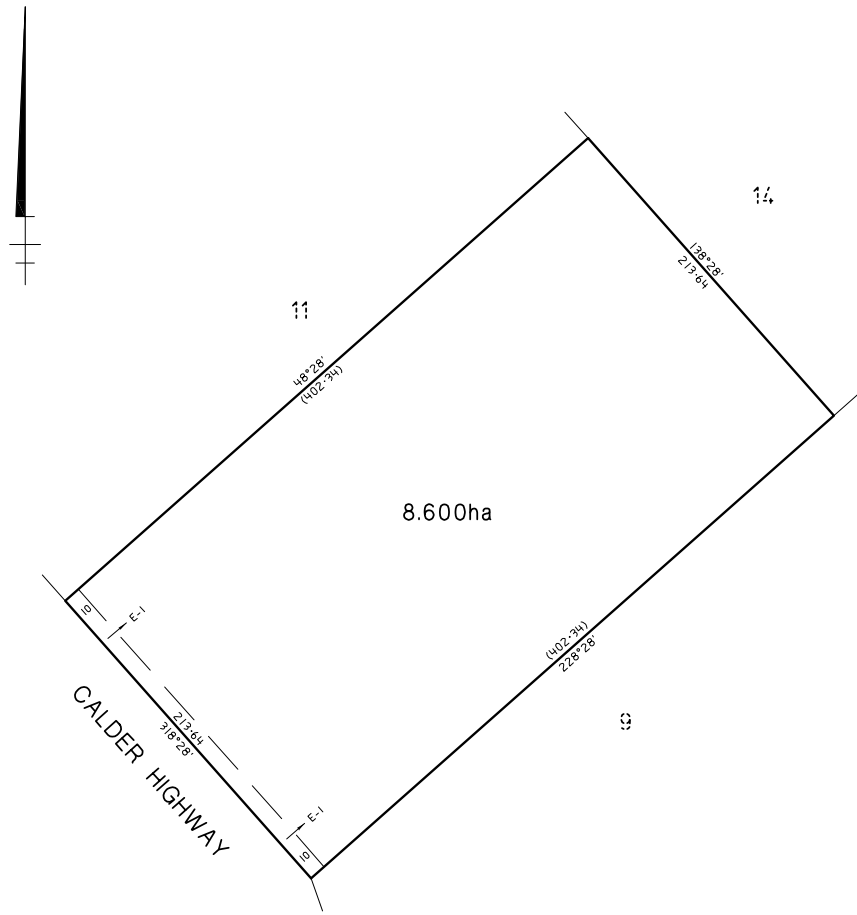

REF. 2004-P142

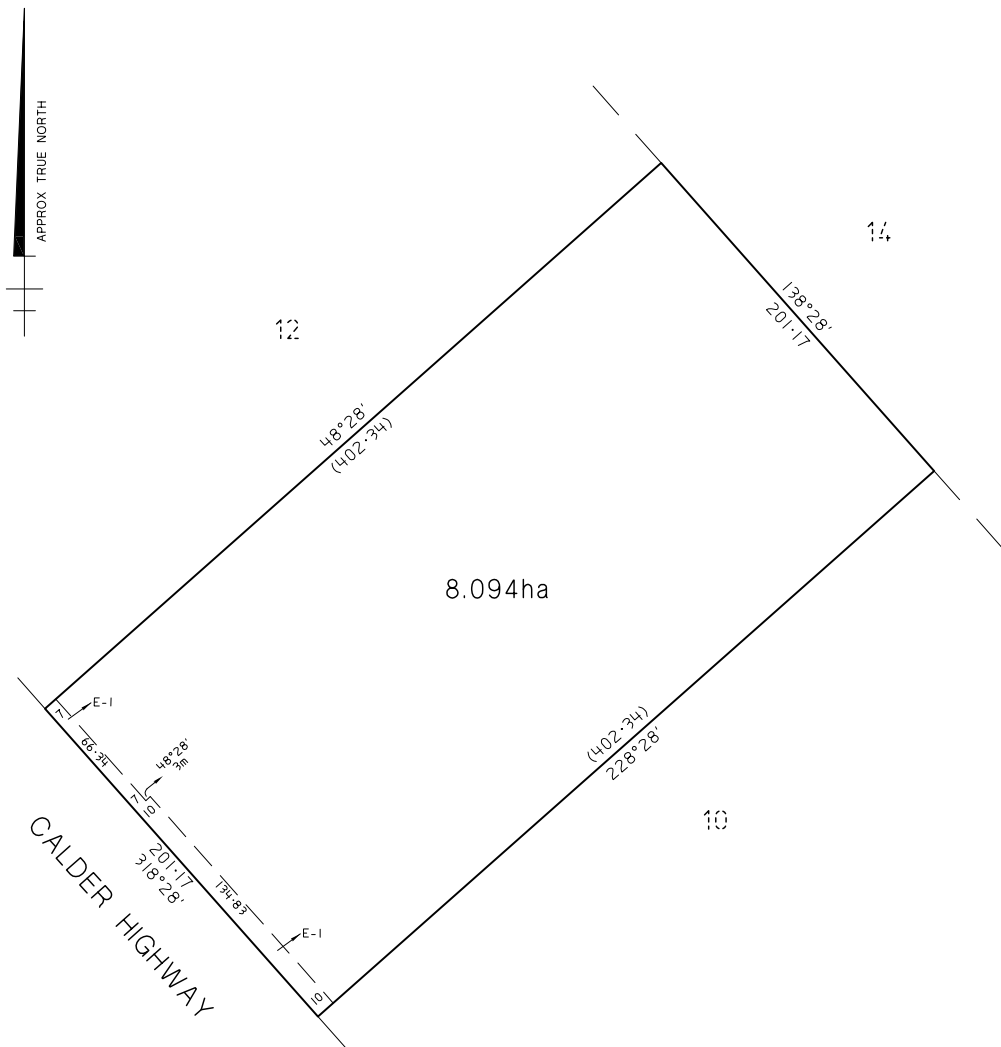

ORIGINAL SCALE
SCALE SHEET SIZE 20 0 20 40 60 80
1:2000 A3 LENGTHS ARE IN METRES

REF. 2004-P143

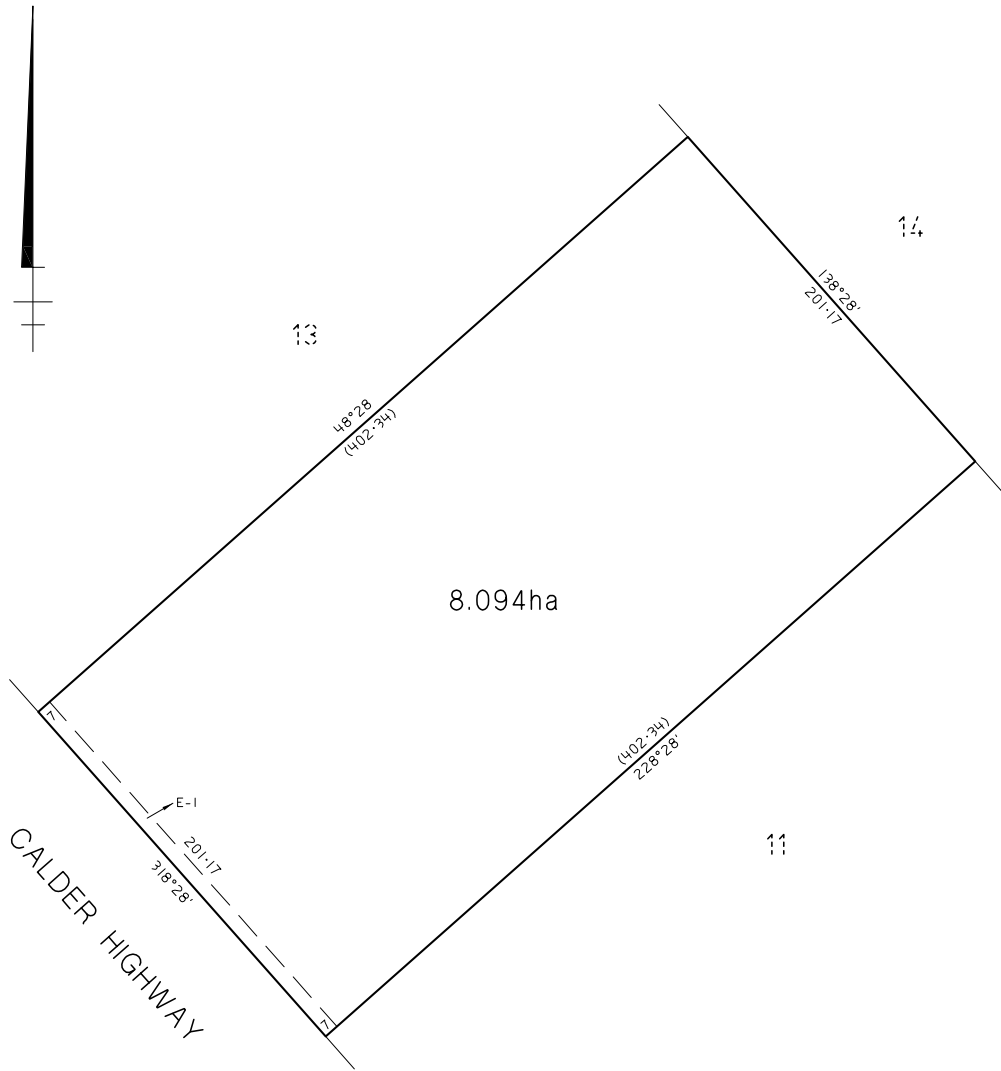

ORIGINAL	SCALE
SCALE SHEET SIZE	20 0 20 40 60 80
1:2000 A3	LENGTHS ARE IN METRES

REF. 2004-P144

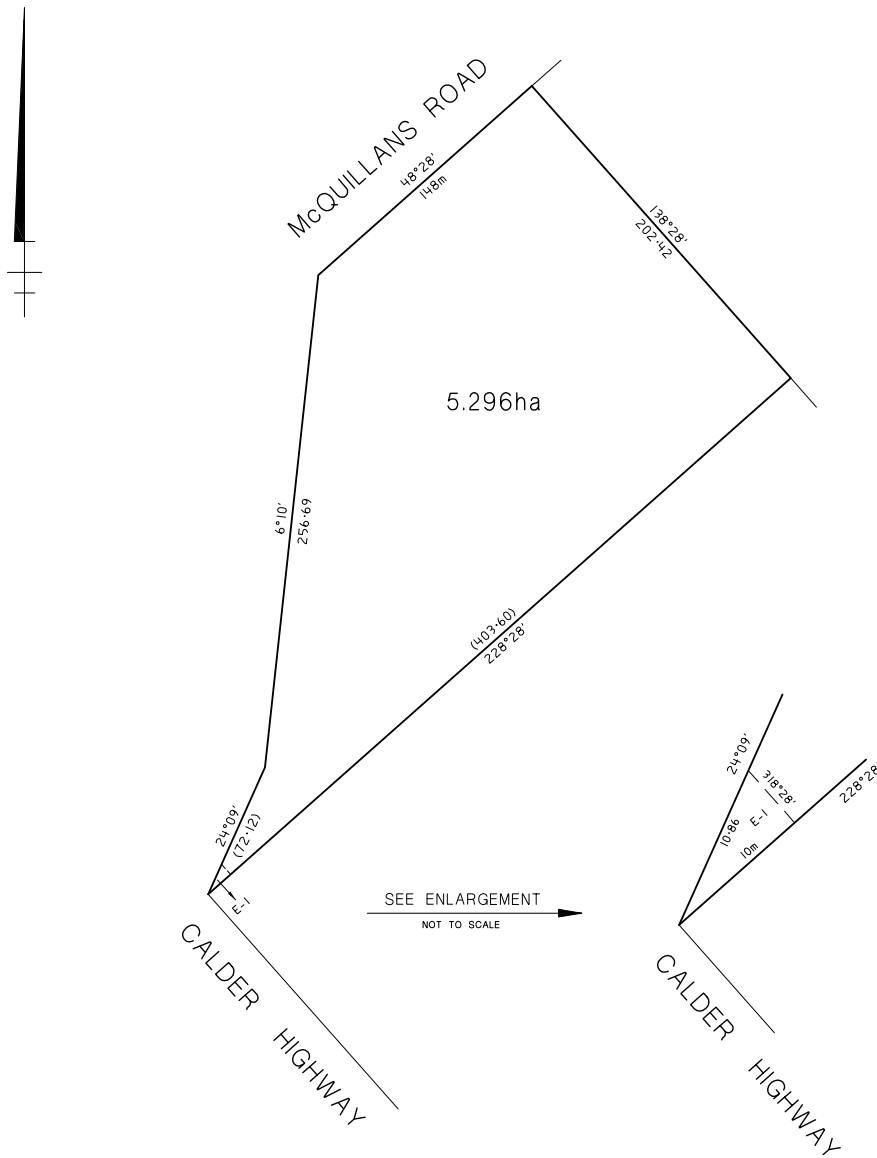

ORIGINAL SCALE
SCALE SHEET SIZE 20 0 20 40 60 80
1:2000 A3 LENGTHS ARE IN METRES REF. 2004-P167

Published with the authority of the Coliban Region Water Corporation.
For and on behalf of the Coliban Region Water Corporation
Signed Andrew Cooney
Name ANDREW COONEY
Corporate Secretary
Dated 8 January 2013

Land Acquisition and Compensation Act 1986

FORM 7

S. 21(a)
Reg. 16

Notice of Acquisition

Compulsory Acquisition of Interest in Land

The Coliban Region Water Corporation (ABN 96 549 082 363), of 37-45 Bridge Street, Bendigo 3550, declares that by this notice it acquires the following interest in the land described as Lot 2 on Title Plan 14448N, Lot 1 on Title Plan 552470S and Crown Allotment 6 Section 3A Parish of Faraday, being more particularly contained within Certificates of Title Volume 10466 Folios 776 and 777 and Volume 6836 Folio 076:

An Easement for a Pipeline for Water Supply purposes over that part of the land shown as 'E-1' on the Plans of Creation of Easement (Ref 2004-P168, 2004-P169 and 2004-P170), which are annexed hereto.

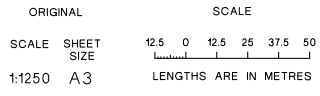
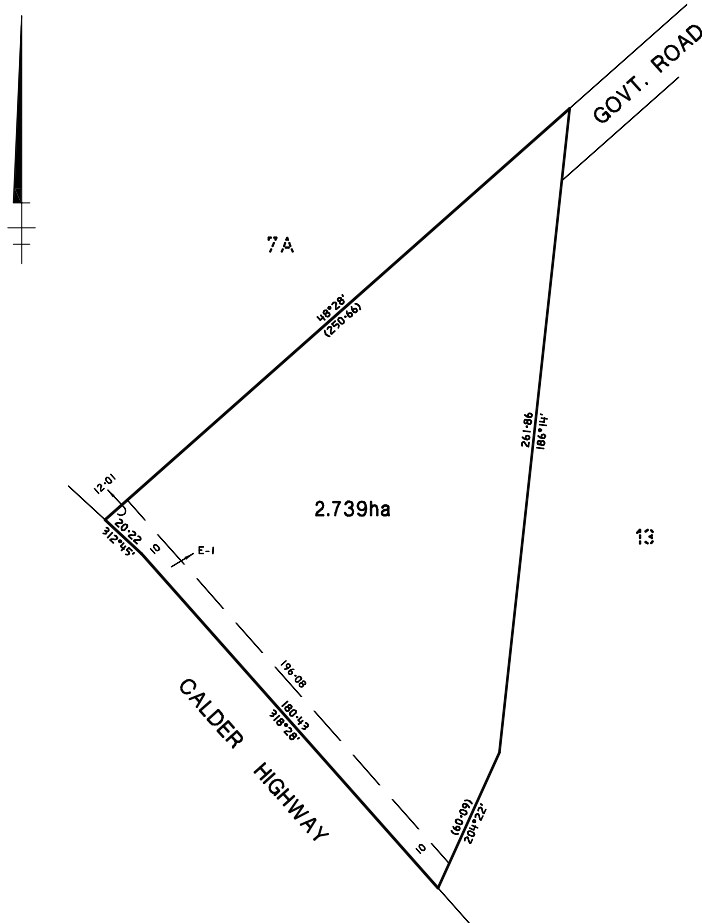

REF. 2004-P168

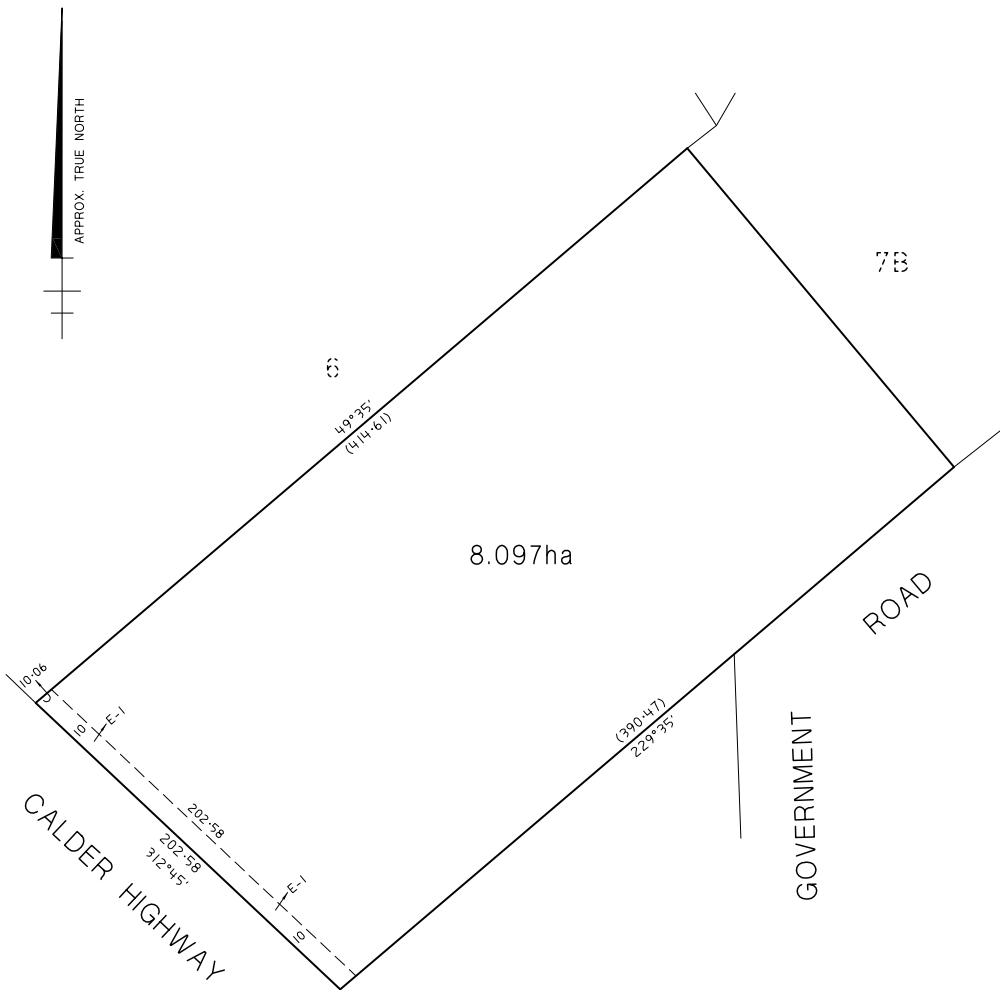

ORIGINAL SCALE SHEET SIZE 1:2000 A3

SCALE 20 0 20 40 60 80

LENGTHS ARE IN METRES

REF. 2004-P169

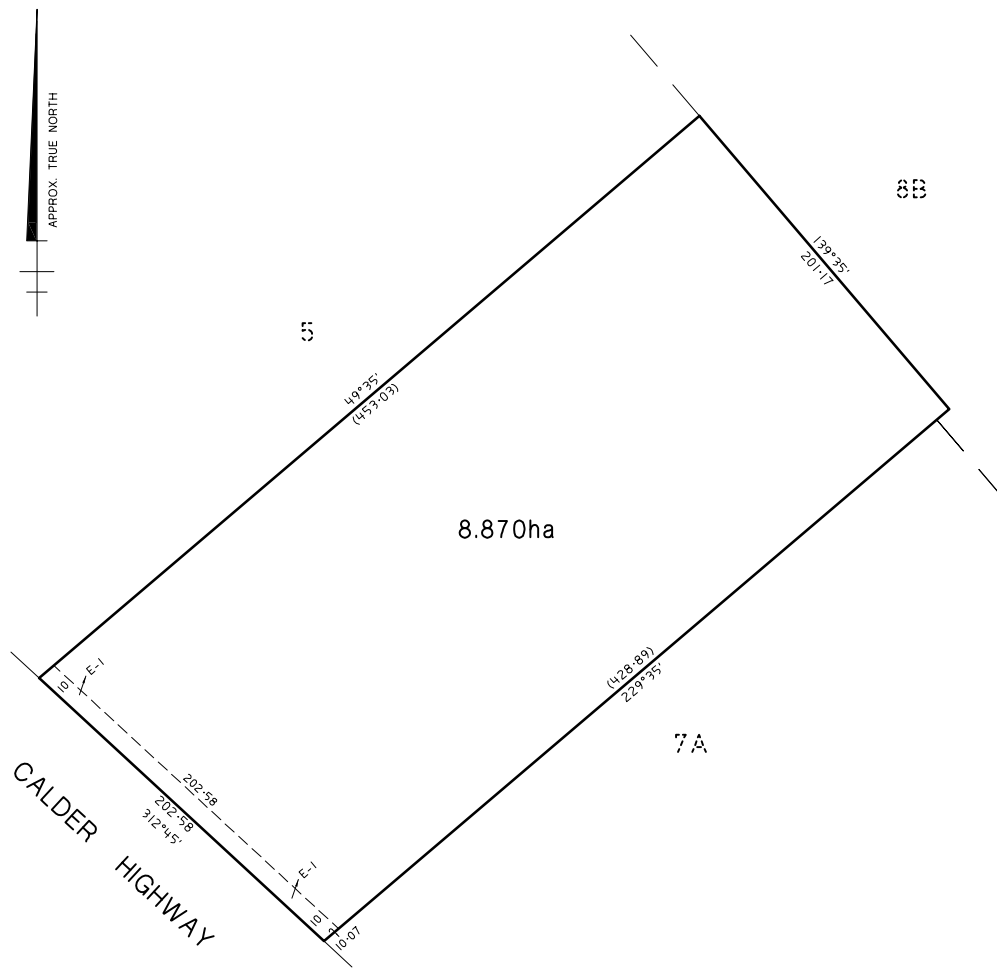

ORIGINAL SCALE
 SCALE SHEET 20 0 20 40 60 80
 SIZE A3
 1:2000 LENGTHS ARE IN METRES

REF. 2004-P170

Published with the authority of the Coliban Region Water Corporation.

For and on behalf of the Coliban Region Water Corporation

Signed Andrew Cooney

Name ANDREW COONEY
 Corporate Secretary

Dated 8 January 2013

Land Acquisition and Compensation Act 1986

FORM 7

S. 21(a)
Reg. 16

Notice of Acquisition

Compulsory Acquisition of Interest in Land

The Coliban Region Water Corporation (ABN 96 549 082 363), of 37-45 Bridge Street, Bendigo 3550, declares that by this notice it acquires the following interest in the land described as Lots 1 and 3 on Title Plan 018794V, being more particularly contained within Certificates of Title Volume 10530 Folio 999 and Volume 10531 Folio 001:

An Easement for a Pipeline for Water Supply purposes over that part of the land shown as 'E-1' on the Plans of Creation of Easement (Ref 2004-P173 and 2004-P183), which are annexed hereto.

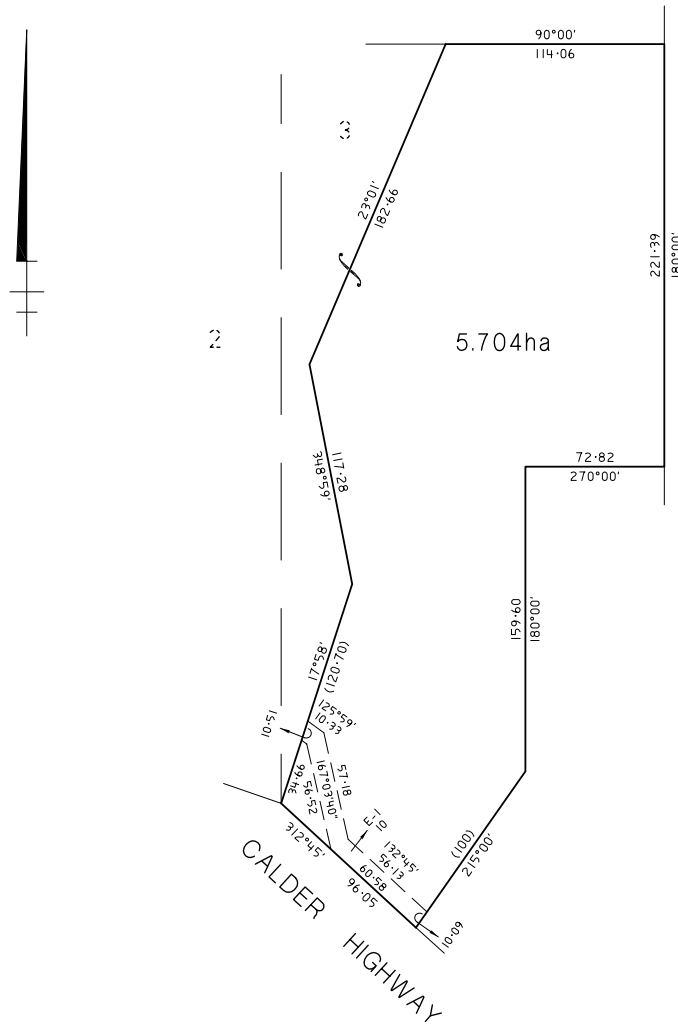

ORIGINAL SCALE

SCALE SHEET SIZE 1:2000 A3

20 0 20 40 60 80

LENGTHS ARE IN METRES

REF. 2004-P173

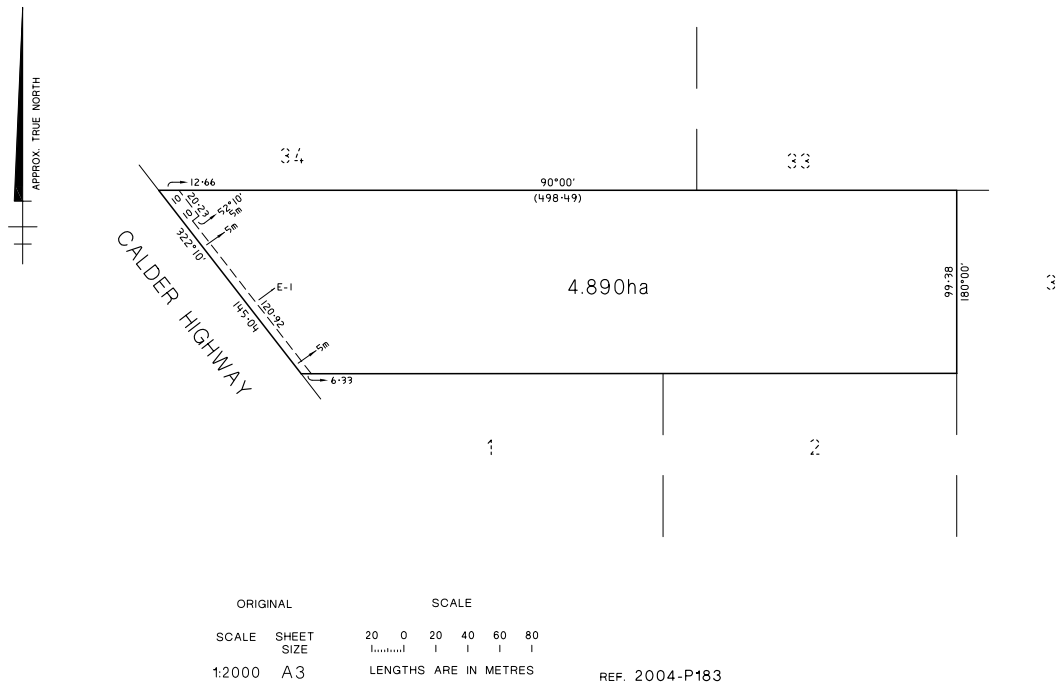

Published with the authority of the Coliban Region Water Corporation.

For and on behalf of the Coliban Region Water Corporation

Signed Andrew Cooney

Name ANDREW COONEY
Corporate Secretary

Dated 8 January 2013

Land Acquisition and Compensation Act 1986

FORM 7

S. 21(a)
Reg. 16

Notice of Acquisition

Compulsory Acquisition of Interest in Land

The Coliban Region Water Corporation (ABN 96 549 082 363), of 37-45 Bridge Street, Bendigo 3550, declares that by this notice it acquires the following interest in the land described as Crown Allotment 34 Section 4 Parish of Harcourt, being more particularly contained within Conveyance No. 345 Book 884:

An Easement for a Pipeline for Water Supply purposes over that part of the land shown as 'E-1' on the Plan of Creation of Easement (Ref 2004-P185), which is annexed hereto.

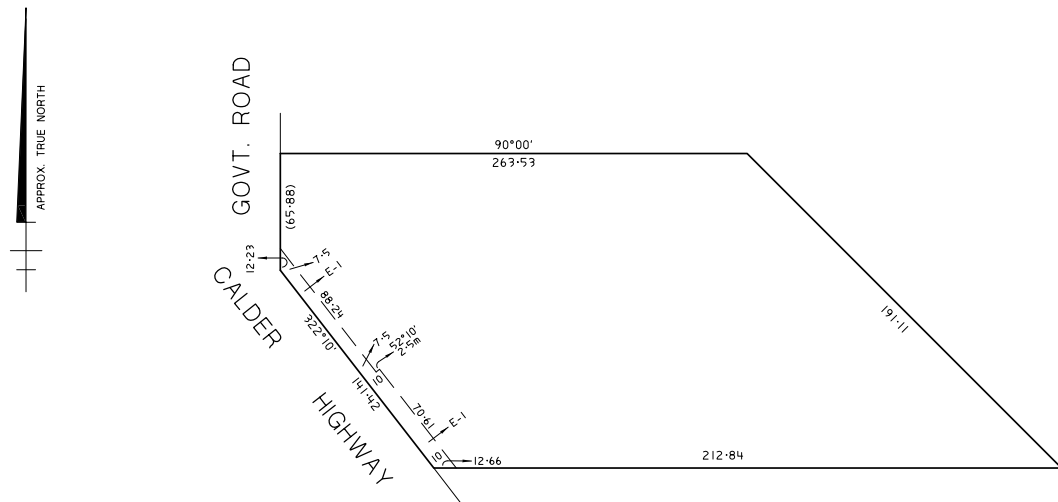

ORIGINAL SCALE
 SCALE SHEET 20 0 20 40 60 80
 SIZE A3
 1:2000 LENGTHS ARE IN METRES REF. 2004-P185

Published with the authority of the Coliban Region Water Corporation.
 For and on behalf of the Coliban Region Water Corporation
 Signed Andrew Cooney
 Name ANDREW COONEY
 Corporate Secretary
 Dated 8 January 2013

Land Acquisition and Compensation Act 1986

FORM 7

S. 21(a)
Reg. 16

Notice of Acquisition

Compulsory Acquisition of Interest in Land

The Coliban Region Water Corporation (ABN 96 549 082 363), of 37–45 Bridge Street, Bendigo 3550, declares that by this notice it acquires the following interest in the land described as Lot 1 on Title Plan 949707A and Lot 1 on Plan of Subdivision 343027Q, being more particularly contained within Certificates of Title Volume 11341 Folio 071 and Volume 10235 Folio 743:

An Easement for a Pipeline for Water Supply purposes over that part of the land shown as 'E-1' on the Plan of Creation of Easement (Ref 2004-P212) and 'E-2' on the Plan of Creation of Easement (Ref 2004-P377), which are annexed hereto.

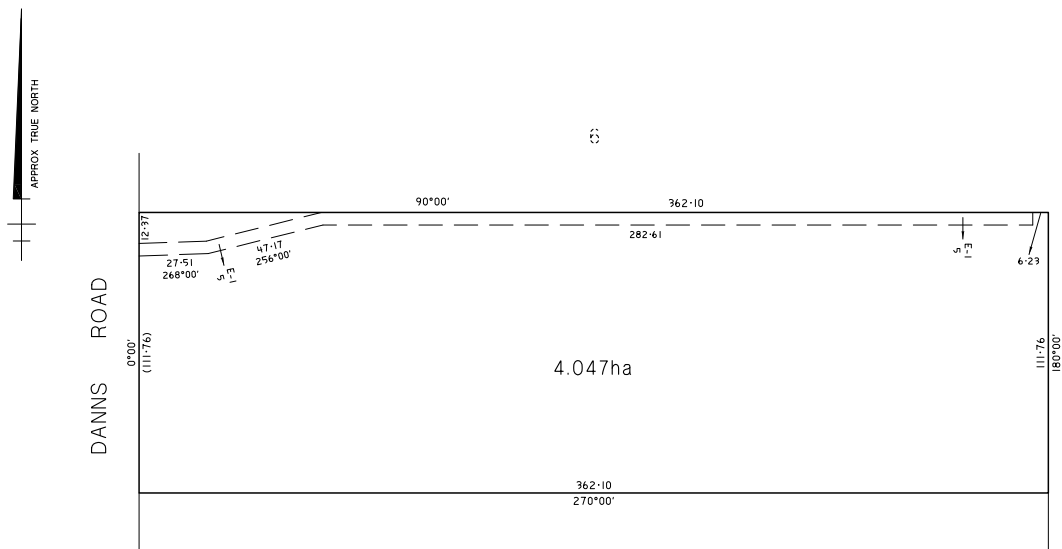

ORIGINAL		SCALE					
SCALE	SHEET SIZE	12.5	0	12.5	25	37.5	50
1:1250	A3	LENGTHS ARE IN METRES					

REF. 2004-P212

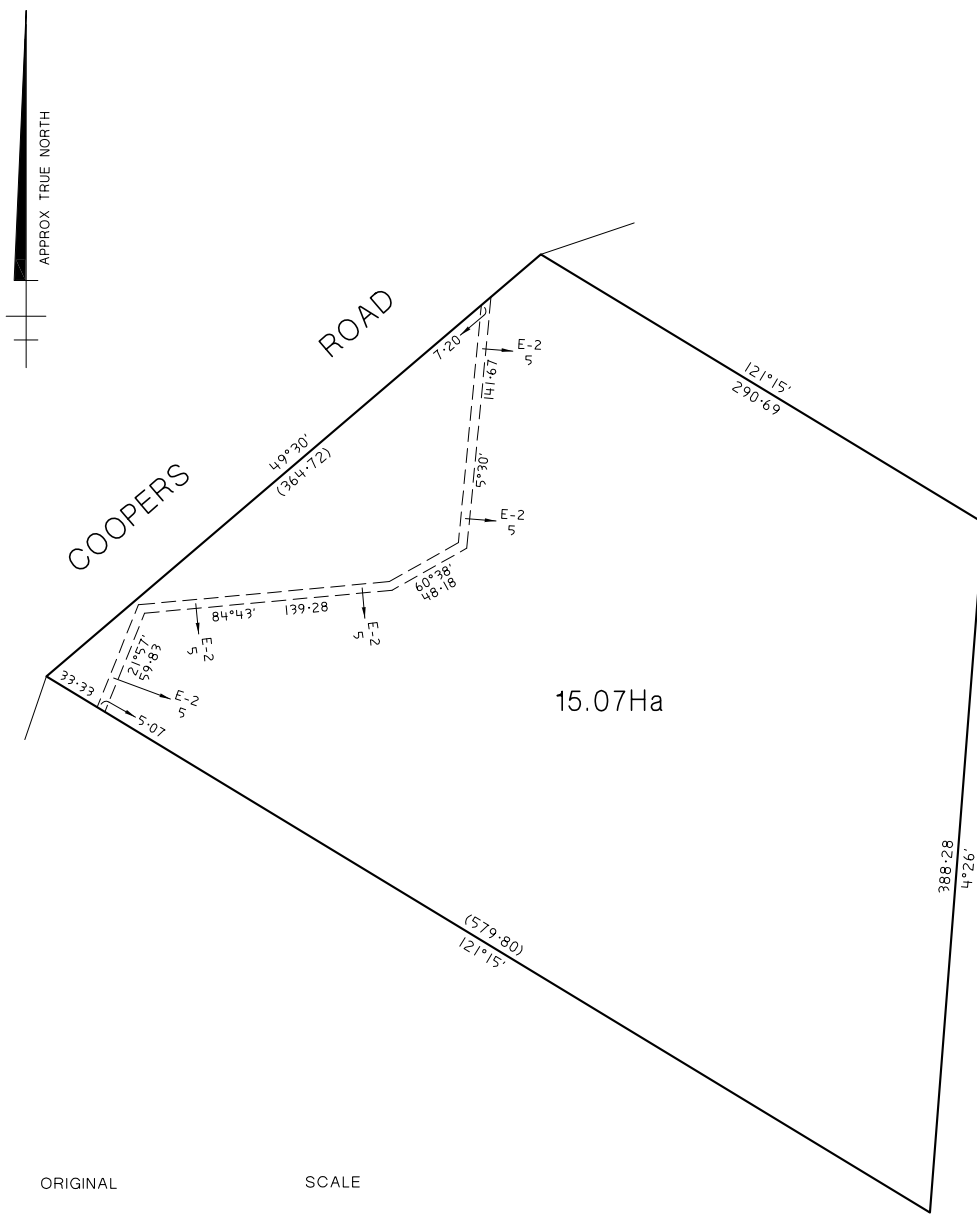

15.07Ha

ORIGINAL	SCALE	
SCALE SHEET SIZE	25 0 25 50 75 100	
1:2500 A3		LENGTHS ARE IN METRES

REF. 2004-P377

Published with the authority of the Coliban Region Water Corporation.
 For and on behalf of the Coliban Region Water Corporation
 Signed Andrew Cooney
 Name ANDREW COONEY
 Corporate Secretary
 Dated 8 January 2013

Land Acquisition and Compensation Act 1986

FORM 7

S. 21(a)
Reg. 16

Notice of Acquisition

Compulsory Acquisition of Interest in Land

The Coliban Region Water Corporation (ABN 96 549 082 363), of 37–45 Bridge Street, Bendigo 3550, declares that by this notice it acquires the following interest in the land described as Crown Allotment 18 Section 3 Parish of Harcourt, being more particularly contained within Certificate of Title Volume 10455 Folio 698:

An Easement for a Pipeline for Water Supply purposes over that part of the land shown as 'E-4' on the Plan of Creation of Easement (Ref 2004-P228), which is annexed hereto.

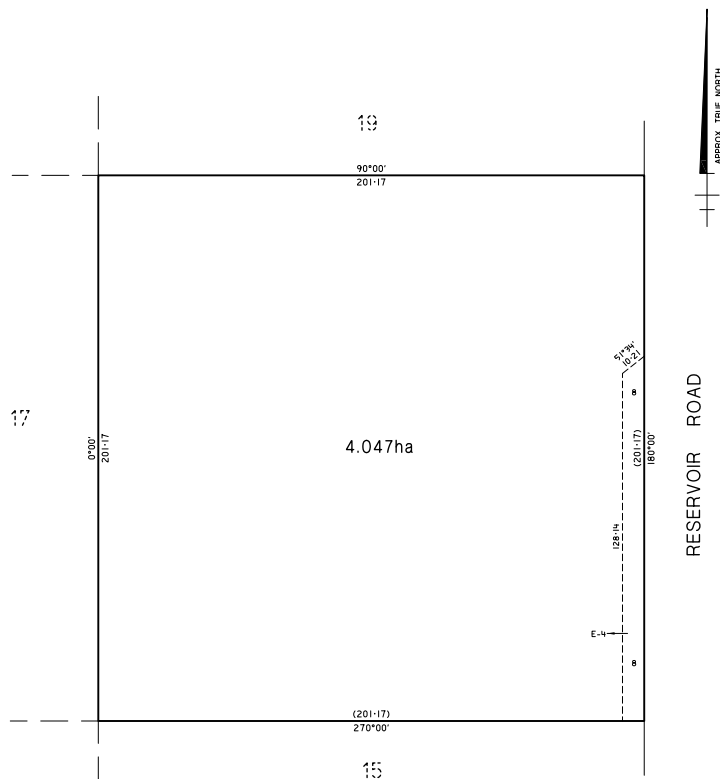

ORIGINAL SCALE
SCALE SHEET 10 0 10 20 30 40
SIZE 1:1000 A3 LENGTHS ARE IN METRES REF. 2004-P228

Published with the authority of the Coliban Region Water Corporation.

For and on behalf of the Coliban Region Water Corporation

Signed Andrew Cooney
Name ANDREW COONEY
Corporate Secretary

Dated 8 January 2013

Land Acquisition and Compensation Act 1986

FORM 7

S. 21(a)
Reg. 16

Notice of Acquisition

Compulsory Acquisition of Interest in Land

The Coliban Region Water Corporation (ABN 96 549 082 363), of 37–45 Bridge Street, Bendigo 3550, declares that by this notice it acquires the following interest in the land described as Lot 3 on Title Plan 108748C, being more particularly contained within Certificate of Title Volume 9521 Folio 750:

An Easement for a Pipeline for Water Supply purposes over that part of the land shown as 'E-3' on the Plan of Creation of Easement (Ref 2004-P230), which is annexed hereto.

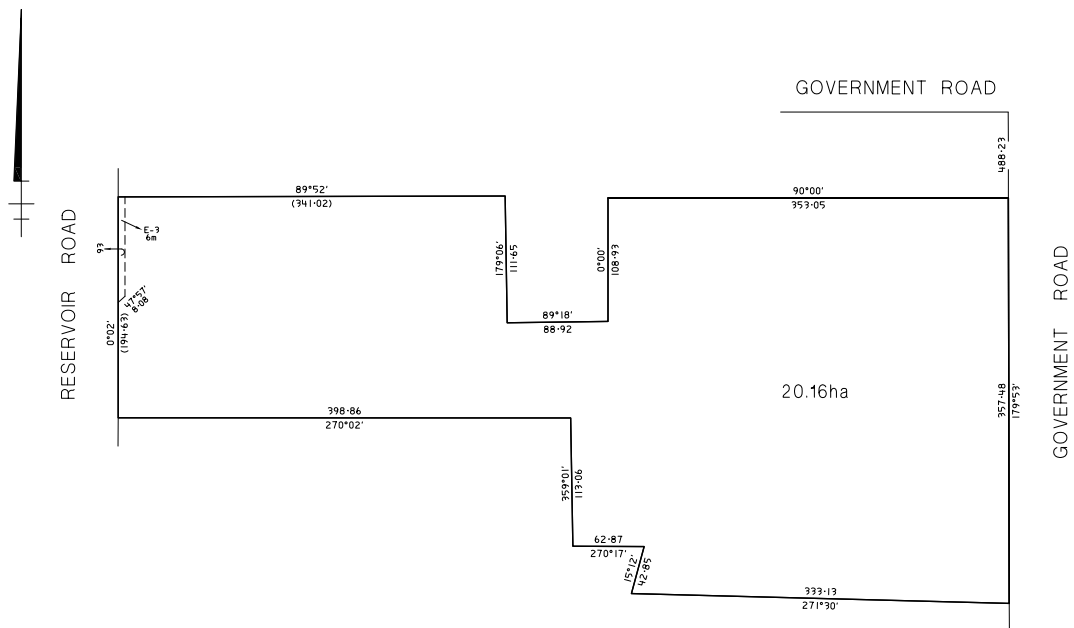

ORIGINAL SCALE
SCALE SHEET 25 0 25 50 75 100
SIZE 1:2500 A3 LENGTHS ARE IN METRES REF. 2004-P230

Published with the authority of the Coliban Region Water Corporation.

For and on behalf of the Coliban Region Water Corporation

Signed Andrew Cooney
Name ANDREW COONEY
Corporate Secretary

Dated 8 January 2013

Land Acquisition and Compensation Act 1986

FORM 7

S. 21(a)
Reg. 16

Notice of Acquisition

Compulsory Acquisition of Interest in Land

The Coliban Region Water Corporation (ABN 96 549 082 363), of 37–45 Bridge Street, Bendigo 3550, declares that by this notice it acquires the following interest in the land described as Lot 1 on Title Plan 172575U, being more particularly contained within Certificate of Title Volume 9231 Folio 141:

An Easement for a Pipeline for Water Supply purposes over that part of the land shown as 'E-1' on the Plan of Creation of Easement (Ref 2004-P242), which is annexed hereto.

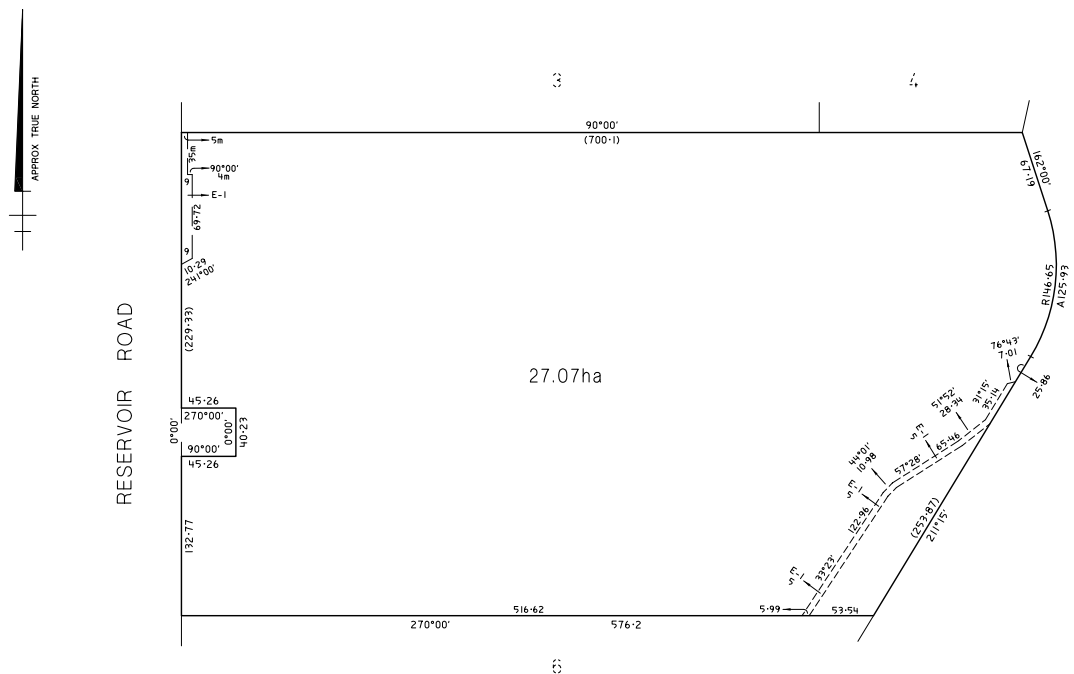

ORIGINAL		SCALE					
SCALE	SHEET SIZE	25	0	25	50	75	100
1:2500	A3	LENGTHS ARE IN METRES					
REF. 2004-P242							

Published with the authority of the Coliban Region Water Corporation.
 For and on behalf of the Coliban Region Water Corporation
 Signed Andrew Cooney
 Name ANDREW COONEY
 Corporate Secretary
 Dated 8 January 2013

Land Acquisition and Compensation Act 1986

FORM 7

S. 21(a)
Reg. 16

Notice of Acquisition

Compulsory Acquisition of Interest in Land

The Coliban Region Water Corporation (ABN 96 549 082 363), of 37-45 Bridge Street, Bendigo 3550, declares that by this notice it acquires the following interest in the land described as Lot 2 on Plan of Subdivision 343027Q, being more particularly contained within Certificate of Title Volume 10235 Folio 744:

An Easement for a Pipeline for Water Supply purposes over that part of the land shown as 'E-2' on the Plan of Creation of Easement (Ref 2004-P378), which is annexed hereto.

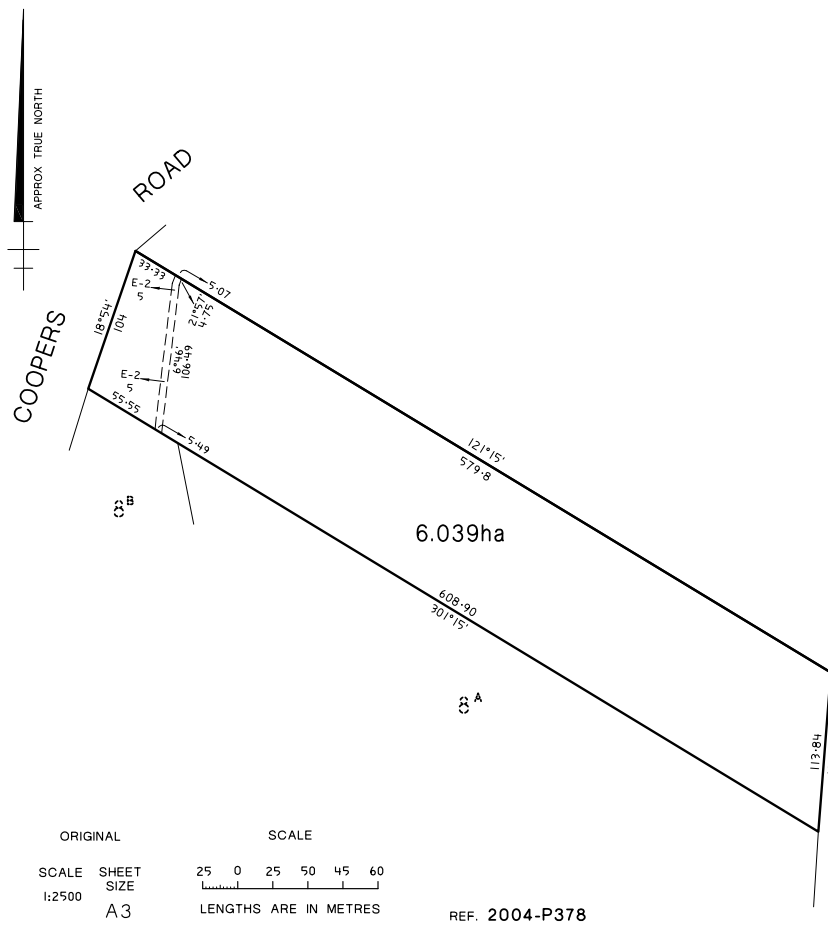

Published with the authority of the Coliban Region Water Corporation.

For and on behalf of the Coliban Region Water Corporation

Signed Andrew Cooney

Name ANDREW COONEY

Corporate Secretary

Dated 8 January 2013

Land Acquisition and Compensation Act 1986
FORM 7

S. 21(a)
 Reg. 16

Notice of Acquisition

Compulsory Acquisition of Interest in Land

The Coliban Region Water Corporation (ABN 96 549 082 363), of 37–45 Bridge Street, Bendigo 3550, declares that by this notice it acquires the following interest in the land described as Lot 1 on Plan of Subdivision 221079R, being more particularly contained within Certificate of Title Volume 9992 Folio 428:

An Easement for a Pipeline for Water Supply purposes over that part of the land shown as 'E-3' on the Plan of Creation of Easement (Ref 2004-P379), which is annexed hereto.

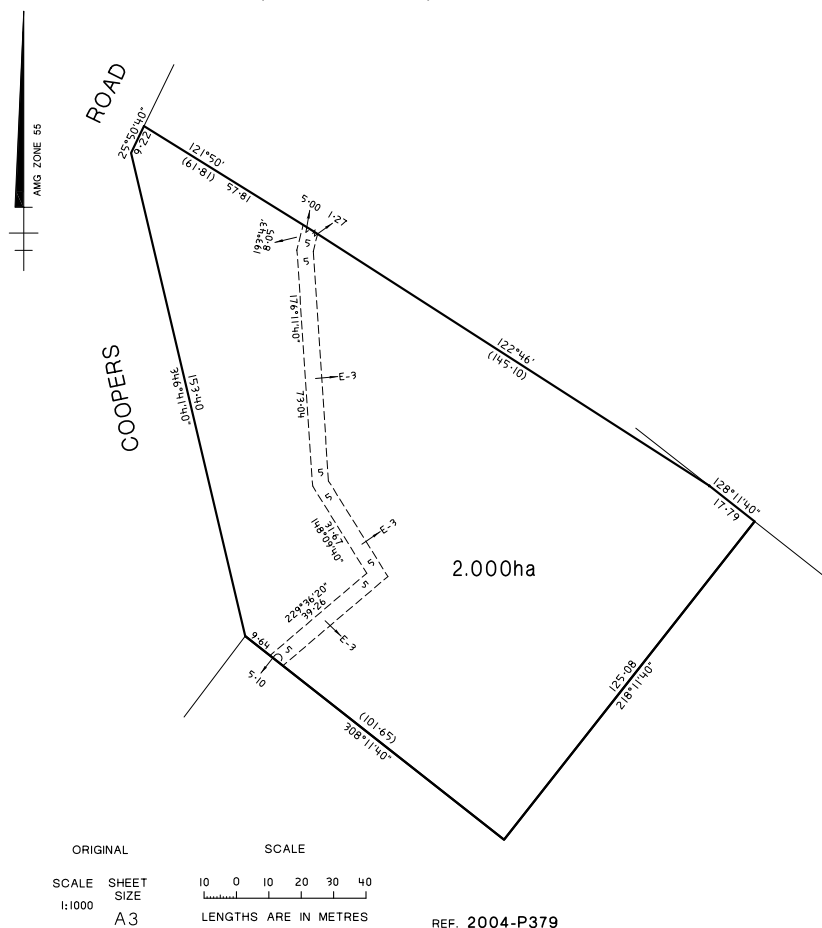

Published with the authority of the Coliban Region Water Corporation.
 For and on behalf of the Coliban Region Water Corporation
 Signed Andrew Cooney
 Name ANDREW COONEY
 Corporate Secretary
 Dated 8 January 2013

Land Acquisition and Compensation Act 1986

FORM 7

S. 21(a)
Reg. 16

Notice of Acquisition

Compulsory Acquisition of Interest in Land

The Coliban Region Water Corporation (ABN 96 549 082 363), of 37–45 Bridge Street, Bendigo 3550, declares that by this notice it acquires the following interest in the land described as Crown Allotment 1 Section 7B Parish of Harcourt, being more particularly contained within Certificate of Title Volume 9402 Folio 249:

An Easement for a Pipeline for Water Supply purposes over that part of the land shown as 'E-1' on the Plan of Creation of Easement (Ref 2004-R041), which is annexed hereto.

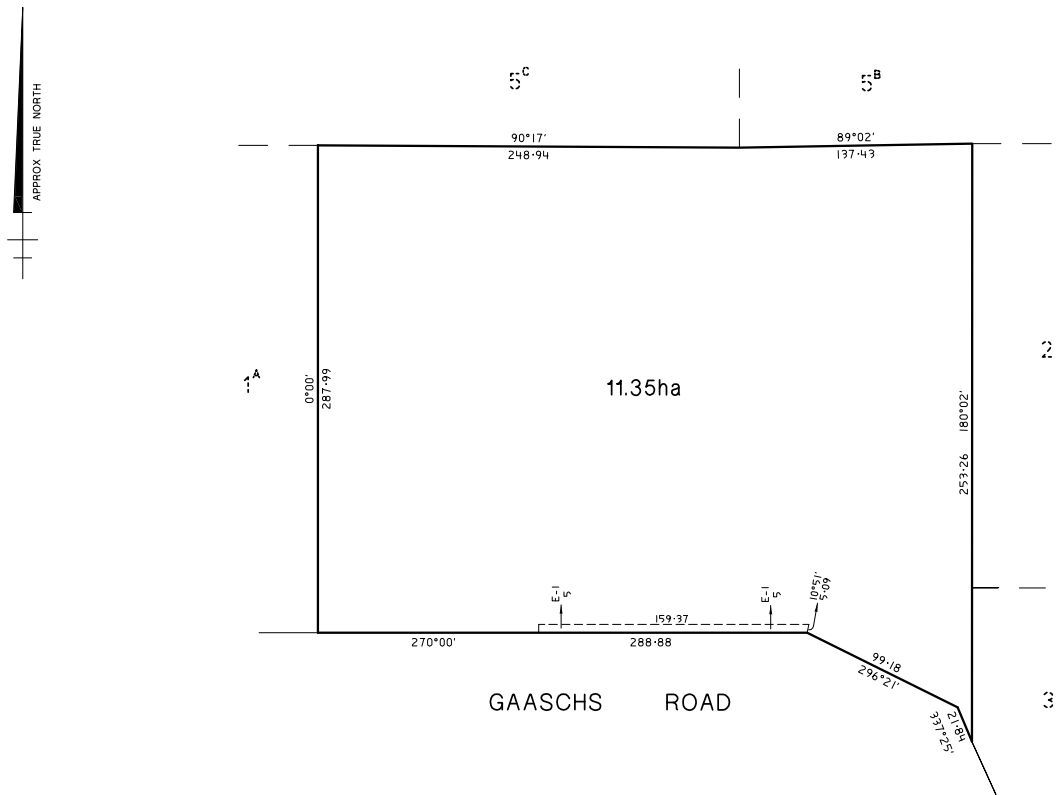

ORIGINAL		SCALE					
SCALE	SHEET SIZE	20	0	20	40	60	80
1:2000	A3					
LENGTHS ARE IN METRES							

REF. 2004-R041

Published with the authority of the Coliban Region Water Corporation.
 For and on behalf of the Coliban Region Water Corporation
 Signed Andrew Cooney
 Name ANDREW COONEY
 Corporate Secretary
 Dated 8 January 2013

Land Acquisition and Compensation Act 1986

FORM 7

S. 21(a)
Reg. 16

Notice of Acquisition

Compulsory Acquisition of Interest in Land

The Coliban Region Water Corporation (ABN 96 549 082 363), of 37–45 Bridge Street, Bendigo 3550, declares that by this notice it acquires the following interest in the land described as Lots 1, 3 and 4 on Title Plan 680345E, being more particularly contained within Certificate of Title Volume 6104 Folio 662:

An Easement for a Pipeline for Water Supply purposes over that part of the land shown as 'E-1' on the Plan of Creation of Easement (Ref 2004-R344), which is annexed hereto.

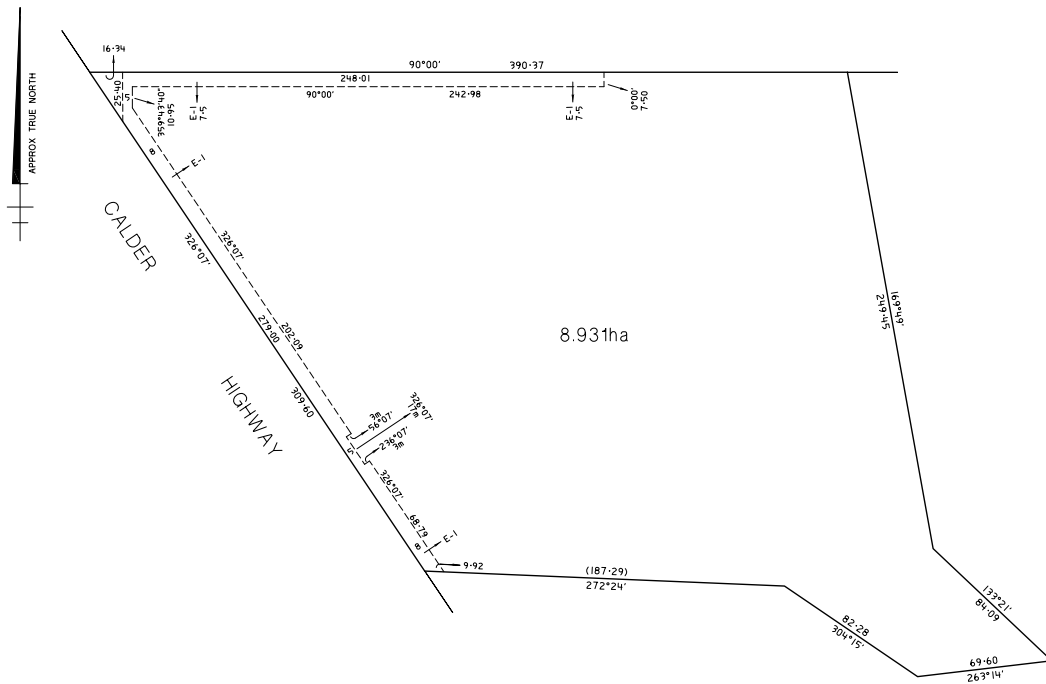

ORIGINAL		SCALE					
SCALE	SHEET SIZE	15	0	15	30	45	60
1:1500	A3	LENGTHS ARE IN METRES					
						REF. 2004-R344	

Published with the authority of the Coliban Region Water Corporation.

For and on behalf of the Coliban Region Water Corporation

Signed Andrew Cooney

Name ANDREW COONEY
Corporate Secretary

Dated 8 January 2013

Land Acquisition and Compensation Act 1986

FORM 7

S. 21(a)
Reg. 16

Notice of Acquisition

Compulsory Acquisition of Interest in Land

The Coliban Region Water Corporation (ABN 96 549 082 363) of 37-45 Bridge Street Bendigo, 3550, declares that by this notice it acquires the following interest in the land described as Lots 1, 2, 3 and 4 on Plan of Subdivision 211545U, being more particularly contained within Certificates of Title Volume 9816 Folios 406, 407, 408 and 409:

An Easement for a Pipeline for Water Supply purposes over that part of the land shown as 'E-2' on the Plans of Creation of Easement (Ref 2004-R345, 2004-R346, 2004-R347 and 2004-R348) which are annexed hereto.

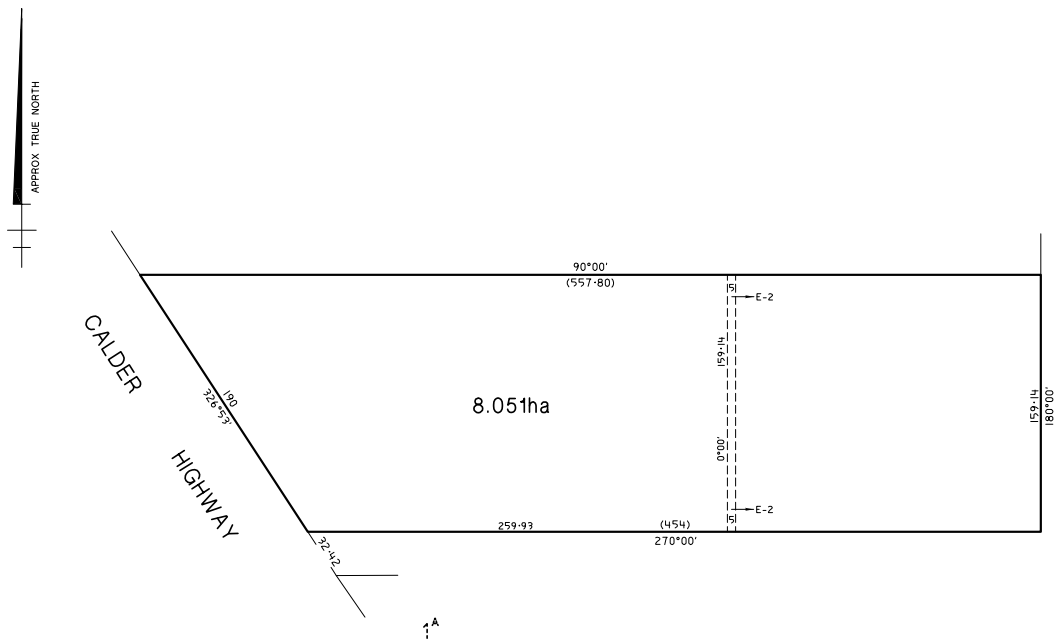

ORIGINAL		SCALE					
SCALE	SHEET SIZE	20	0	20	40	60	80
1:2000	A3	LENGTHS ARE IN METRES					

REF. 2004-R345

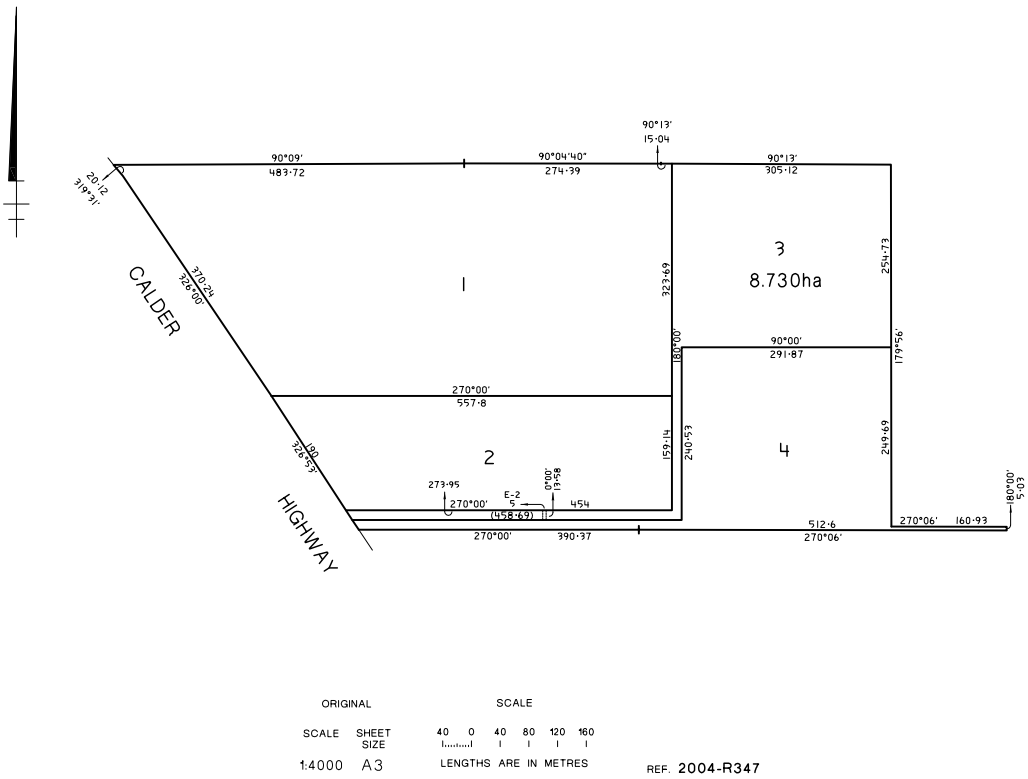
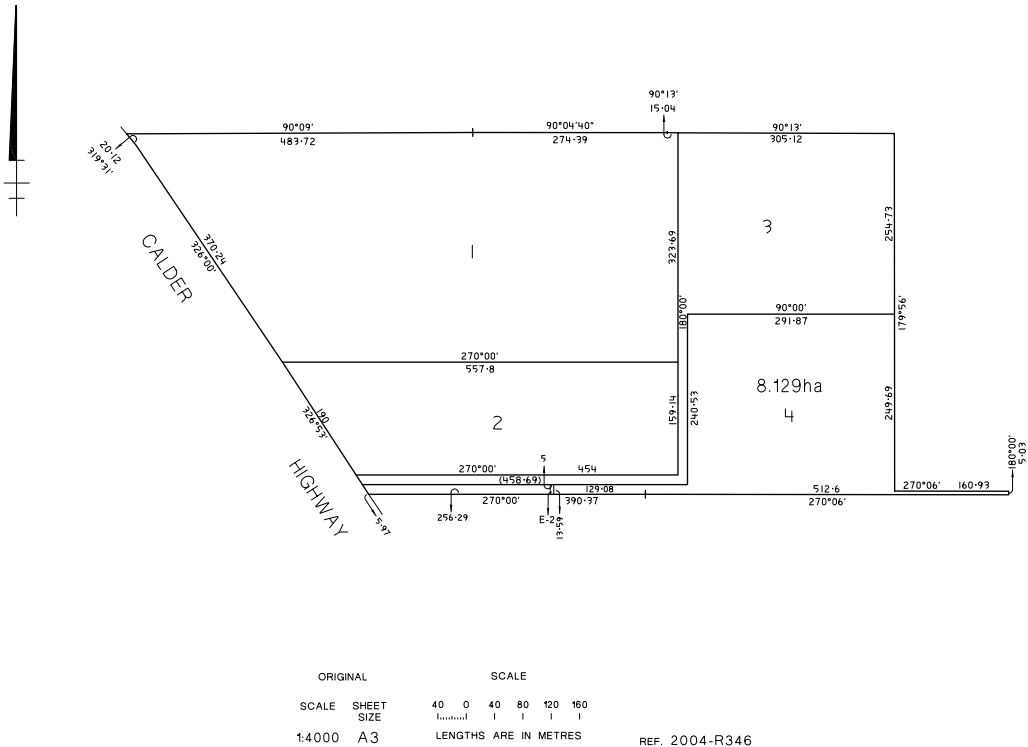

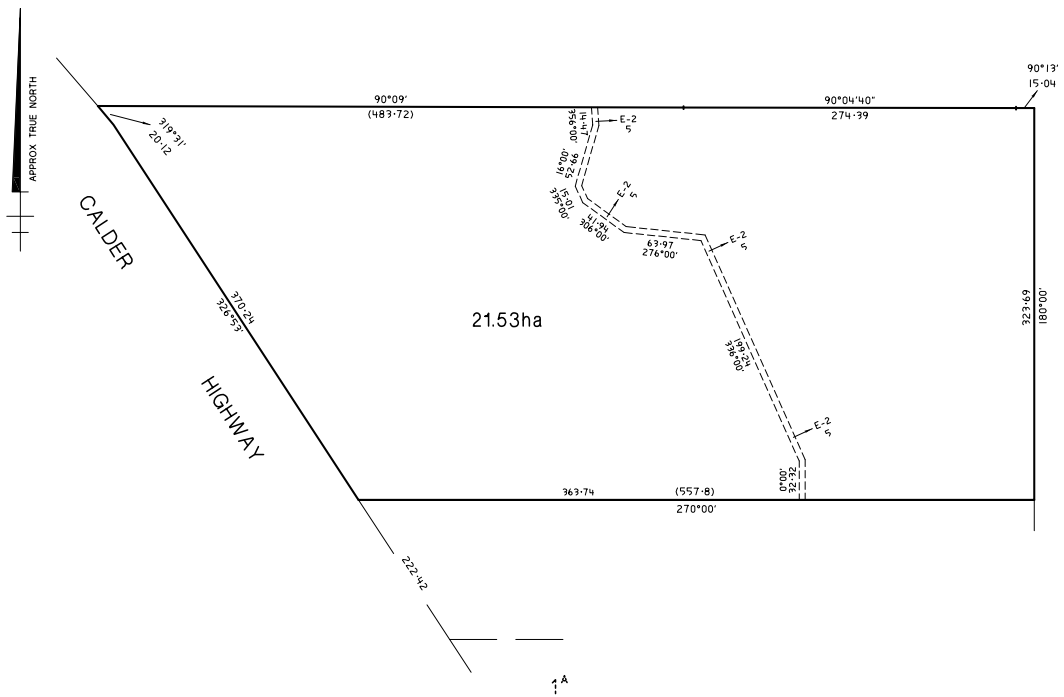

ORIGINAL SCALE
 SCALE SHEET 25 0 25 50 75 100
 SIZE 1:2500 A3 LENGTHS ARE IN METRES REF. 2004-R348

Published with the authority of the Coliban Region Water Corporation.
 For and on behalf of the Coliban Region Water Corporation
 Signed Andrew Cooney
 Name ANDREW COONEY
 Corporate Secretary
 Dated 8 January 2013

Land Acquisition and Compensation Act 1986

FORM 7

S. 21(a)
Reg. 16

Notice of Acquisition

Compulsory Acquisition of Interest in Land

The Coliban Region Water Corporation (ABN 96 549 082 363), of 37-45 Bridge Street, Bendigo 3550, declares that by this notice it acquires the following interest in the land described as Lot 1 on Title Plan 602640T, being more particularly contained within Certificate of Title Volume 10001 Folio 423:

An Easement for a Pipeline for Water Supply purposes over that part of the land shown as 'E-2' on the Plan of Creation of Easement (Ref 2004-R391), which is annexed hereto.

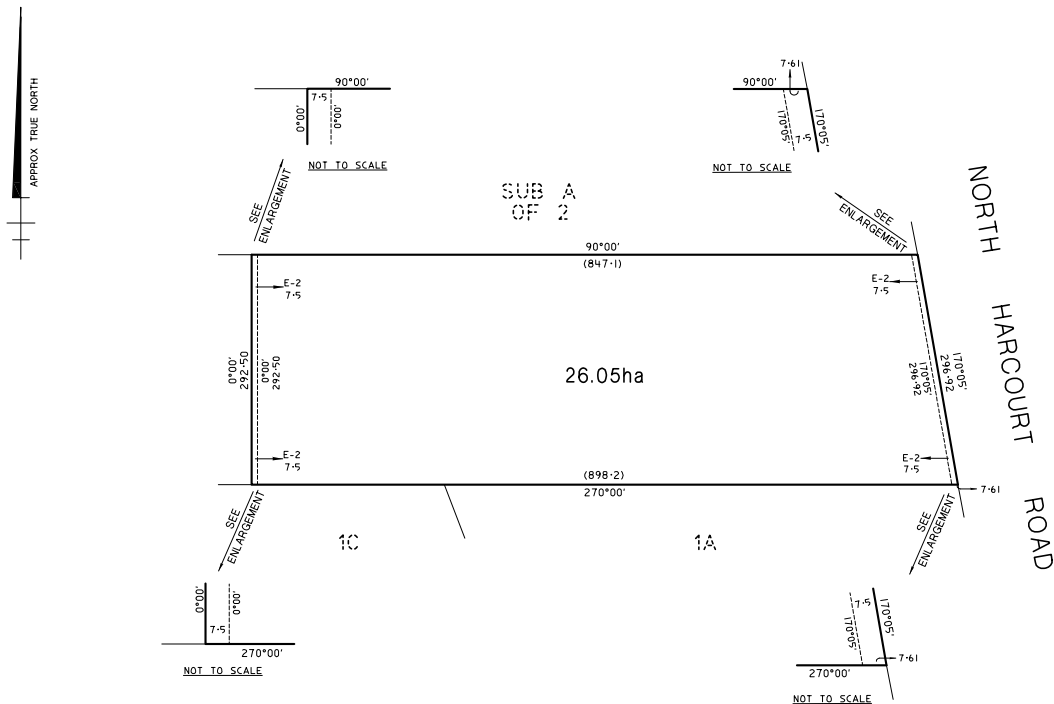

ORIGINAL	SCALE	
SCALE SHEET SIZE	40 0 40 80 120 160	
1:4000 A3	LENGTHS ARE IN METRES	REF. 2004-R391

Published with the authority of the Coliban Region Water Corporation.

For and on behalf of the Coliban Region Water Corporation

Signed Andrew Cooney

Name ANDREW COONEY
Corporate Secretary

Dated 8 January 2013

Land Acquisition and Compensation Act 1986

FORM 7

S. 21(a)
Reg. 16

Notice of Acquisition

Compulsory Acquisition of Interest in Land

The Coliban Region Water Corporation (ABN 96 549 082 363), of 37-45 Bridge Street, Bendigo 3550, declares that by this notice it acquires the following interest in the land described as Lot 14 on Plan of Subdivision 6496, being more particularly contained within Certificate of Title Volume 8080 Folio 546:

An Easement for a Pipeline for Water Supply purposes over that part of the land shown as 'E-1' on the Plan of Creation of Easement (Ref 2004-R392), which is annexed hereto.

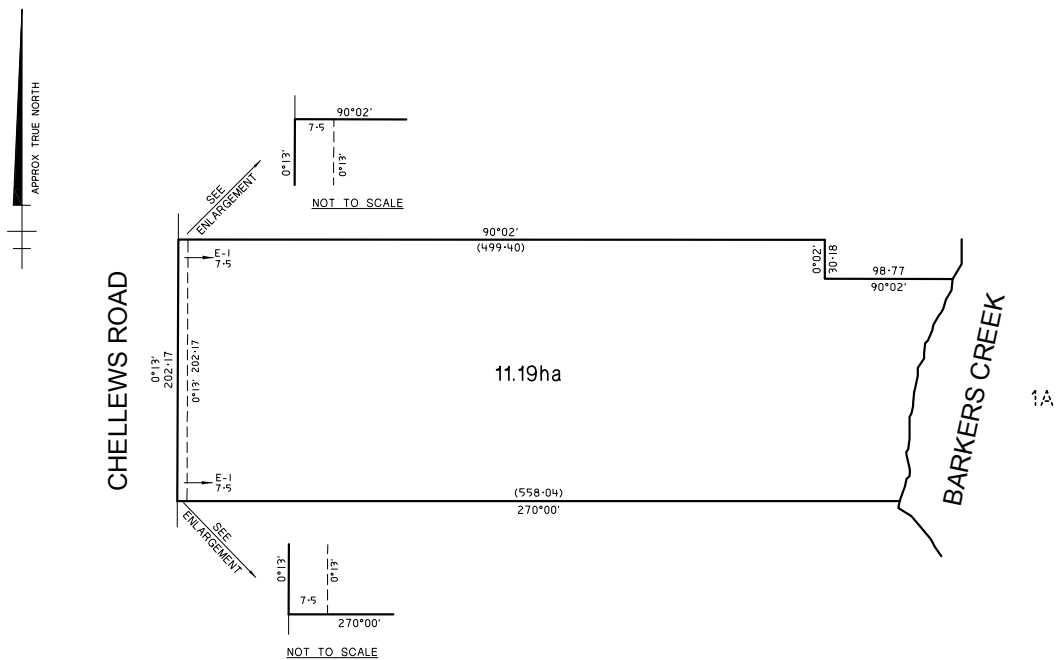

ORIGINAL	SCALE	
SCALE	SHEET	25 0 25 50 75 100
SIZE	
1:2500	A3	LENGTHS ARE IN METRES
		REF. 2004-R392

Published with the authority of the Coliban Region Water Corporation.
 For and on behalf of the Coliban Region Water Corporation
 Signed Andrew Cooney
 Name ANDREW COONEY
 Corporate Secretary
 Dated 8 January 2013

Land Acquisition and Compensation Act 1986

FORM 7

S. 21(a)
Reg. 16

Notice of Acquisition

Compulsory Acquisition of Interest in Land

The Coliban Region Water Corporation (ABN 96 549 082 363), of 37–45 Bridge Street, Bendigo 3550, declares that by this notice it acquires the following interest in the land described as Lots 8, 9 and 10 on Plan of Subdivision 6496, being more particularly contained within Certificate of Title Volume 6771 Folio 085:

An Easement for a Pipeline for Water Supply purposes over that part of the land shown as 'E-2' on the Plan of Creation of Easement (Ref 2004-R396), which is annexed hereto.

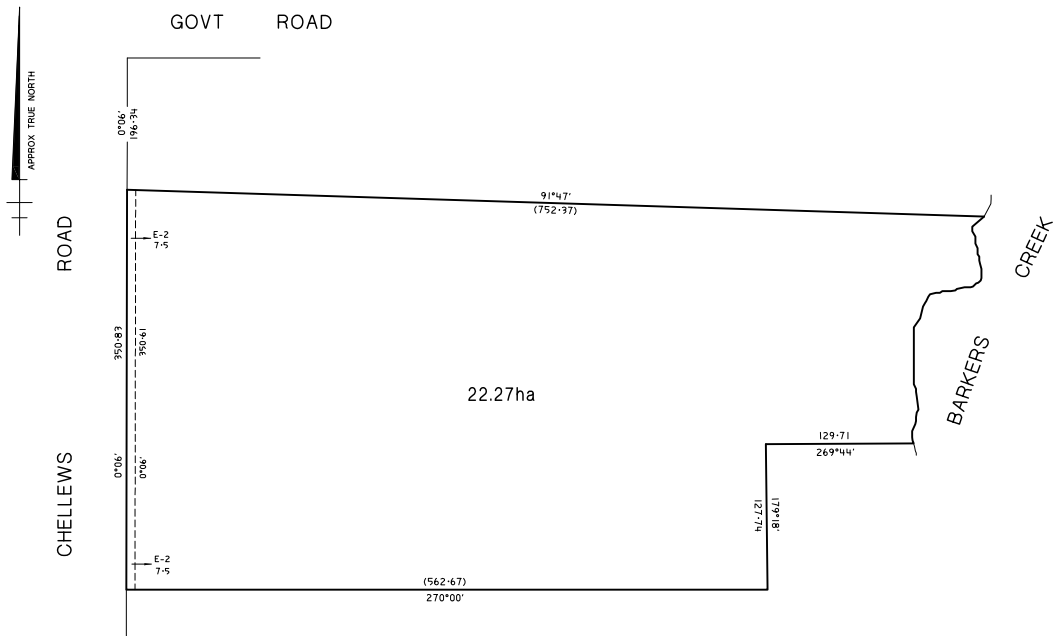

ORIGINAL	SCALE	
SCALE SHEET SIZE	25 0 25 50 75 100	
1:2500 A3	LENGTHS ARE IN METRES	REF. 2004-R396

Published with the authority of the Coliban Region Water Corporation.

For and on behalf of the Coliban Region Water Corporation

Signed Andrew Cooney

Name ANDREW COONEY
Corporate Secretary

Dated 8 January 2013

This page was left blank intentionally

bluestar * **PRINT**

The *Victoria Government Gazette* is published by Blue Star Print with the authority of the Government Printer for the State of Victoria

© State of Victoria 2013

This publication is copyright. No part may be reproduced by any process except in accordance with the provisions of the Copyright Act.

Address all enquiries to the Government Printer for the State of Victoria

Level 2, 1 Macarthur Street
Melbourne 3002
Victoria Australia

How To Order**Mail Order****Victoria Government Gazette**

Level 5, 460 Bourke Street
Melbourne 3000
PO Box 1957 Melbourne 3001
DX 106 Melbourne

**Telephone**

(03) 8523 4601

**Fax**

(03) 9600 0478

email

gazette@bluestargroup.com.au

**Retail & Mail Sales****Victoria Government Gazette**

Level 5, 460 Bourke Street
Melbourne 3000
PO Box 1957 Melbourne 3001

**Telephone**

(03) 8523 4601

**Fax**

(03) 9600 0478

**Retail Sales****Victorian Government Bookshop**

Level 20, 80 Collins Street
Melbourne 3000

**Telephone**

1300 366 356

**Fax**

(03) 9208 3316

Price Code B