



Victoria Government Gazette

By Authority of Victorian Government Printer

No. G 25 Thursday 25 June 2015

www.gazette.vic.gov.au

GENERAL

TABLE OF PROVISIONS

Private Advertisements		Sales by the Sheriff	
Waverley Arts Society Inc. (in Liquidation)	1393	Mark Stephen Smythe	1397
Dissolution of Partnership		Stephen Carl Perryman and Benjie Berryman	1397
Resolve Hand Therapy Specialists	1393	Baljinder Singh	1398
Estates of Deceased Persons		Johannes Hendrikus Petrus Smit	1398
A. B. Natoli Pty	1393	Government and Outer Budget Sector	
Aughtersons	1393	Agencies Notices	1399
Brendan Holland & Michael Cahir	1393	Orders in Council	1452
David Dethridge	1393	Acts: Crown Lands (Reserves);	
Hartleys Lawyers	1394	Honorary Justices;	
Henderson & Ball	1394	Land;	
J. A. Middlemis	1394	Occupational Health and Safety;	
Kliger Partners Lawyers	1394	Transport (Compliance and Miscellaneous);	
Lynette Nash	1394	Workplace Injury Rehabilitation and Compensation	
Mahons with Yuncken & Yuncken	1394	Obtainables	1459
Phillip Bing & Associates	1395		
Portelli & Co.	1395		
Rudolfo De Nardo	1395		
Sandhurst Trustees Limited	1395		
Slater & Gordon	1395		
Stidston Warren Lawyers	1395		
T. J. Mulvany & Co.	1395		
Terence McMullan	1396		
Tragear & Harris Lawyers	1396		
Wilckens Roche Lawyers	1396		
Wills Simmonds Lawyers	1396		
Wills & Wealth	1397		
Wollerman Shacklock Lawyers	1397		

Advertisers Please Note

As from 25 June 2015

The last Special Gazette was No. 171 dated 24 June 2015.

The last Periodical Gazette was No. 1 dated 27 May 2015.

How To Submit Copy

- See our webpage www.gazette.vic.gov.au
 - or contact our office on 8523 4601
between 8.30 am and 5.30 pm Monday to Friday
-

PRIVATE ADVERTISEMENTS

Associations Incorporation Reform Act 2012

NOTICE OF APPOINTMENT

Waverley Arts Society Inc.
(In Liquidation)
ABN 65 153 997 419
A0003505L

Take notice that at a special meeting of the members of the Association held on 31 March 2015 it was resolved that the Association be wound up voluntarily and that Bruce Mulvaney be appointed liquidator.

Dated 18 June 2015

BRUCE MULVANEY, liquidator,
Suite 3, Level 4, 852–858 Glenferrie Road,
Hawthorn, Victoria 3122.

DISSOLUTION OF PARTNERSHIP

Notice is hereby given that the partnership hitherto existing at: Berwick, Malvern, Waverley, East Melbourne, Richmond, Sunshine, Blackburn and Parkdale, Victoria, between BJC Nominees Pty Ltd and MFN Pty Ltd, trading under the name Resolve Hand Therapy Specialists, was dissolved on 30 June 2012.

Re: MARY SASSELLA, late of 4 King Street, Hawthorn East, Victoria, gentlelady, deceased.

Creditors, next-of-kin and others having claims in respect of the estate of the deceased, who died on 25 March 2015, are required by the trustee, Michael Anthony Sassella, to send particulars to the trustee, care of the undermentioned solicitors, by a date not later than two months from the date of publication hereof, after which date the trustee may convey or distribute the assets, having regard only to the claims of which he has notice.

A. B. NATOLI PTY, solicitors,
24 Cotham Road, Kew 3101.

MARY AGNES GARRIGAN, late of Unit 2, 15 Bourke Street, Ringwood, Victoria, machinist, deceased.

Creditors, next-of-kin and others having claims in respect of the estate of the abovenamed deceased, who died on 6 March 2015, are

required by the executor to send particulars thereof to him, care of the undermentioned solicitors, within two months from the date of publication of this notice, after which date the executor will distribute the estate, having regard only to claims of which he has notice.

AUGHTERSONS, solicitors,
267 Maroondah Highway, Ringwood,
Victoria 3134.

Re: Estate of HENRY NORMAN HAZELL, late of Opal Aged Care, Racecourse Road, Mount Martha, Victoria, deceased.

Creditors, next-of-kin or others having claims in respect of the estate of the deceased, who died on 31 March 2015, are required by the trustee, Graeme Thomas Keys, to send particulars of their claims to the trustee, care of the undermentioned legal practitioners, by a date not later than two months from the date of publication of this notice, after which date the trustee may convey or distribute the assets, having regard only to the claims of which he then has notice.

BRENDAN HOLLAND & MICHAEL CAHIR,
legal practitioners,
130 Balcombe Road, Mentone 3194.

Re: Estate of TONI MARIA McDONALD, late of Unit 4, 438–440 Nepean Highway, Parkdale, Victoria, deceased.

Creditors, next-of-kin or others having claims in respect of the estate of the deceased, who died on 28 March 2015, are required by the trustee, Kristine Ann Jarman, to send particulars of their claims to the trustee, care of the undermentioned legal practitioners, by a date not later than two months from the date of publication of this notice, after which date the trustee may convey or distribute the assets, having regard only to the claims of which she then has notice.

BRENDAN HOLLAND & MICHAEL CAHIR,
legal practitioners,
130 Balcombe Road, Mentone 3194.

Re: PATRICIA SHIRLEY CORDNER, late of Arcare Bellarine, 5 Knowles Grove, Point Lonsdale, widow, deceased.

Creditors, next-of-kin and others having claims in respect of the estate of the deceased, who died on 19 March 2015, are required by the trustee, Equity Trustees Limited, to send

particulars of their claims to the trustee, care of the undermentioned solicitor, by 31 August 2015, after which date the trustee may convey or distribute the assets, having regard only to the claims of which the trustee then has notice.

DAVID DETHRIDGE, solicitor,
43 Ryrie Street, Geelong, Victoria 3220.

Re: GARY JOHN WOODS, late of 87 Condon Crescent, Venus Bay, in the State of Victoria, economist, deceased.

Creditors, next-of-kin and all others having claims in respect of the estate of the said deceased, who died on 25 December 2014, are required by Robert John Harrop Woods, in the Will called Robert Woods, the executor of the estate of the deceased, to send particulars of their claims to the said executor, care of the undermentioned solicitors, within two months from the date of publication of this notice, after which date the executor may convey or distribute the assets, having regard only to the claims of which he then has notice.

HARTLEYS LAWYERS,
461 Ballarat Road (PO Box 227), Sunshine,
Victoria 3020.

Re: SHEILA BIGNELL, deceased.

Creditors, next-of-kin and others having claims in respect of the estate of the deceased, who died on 22 December 2014, are required by the trustees, Julia Breen and William Hicks Hall, care of Henderson & Ball, lawyers, 17 Cotham Road, Kew, to send particulars to the trustees by 25 August 2015, after which date the trustees may convey or distribute the assets, having regard only to the claims of which the trustees have notice.

HENDERSON & BALL,
17 Cotham Road, Kew 3101.

JACK VERNIE DUCE, late of 4 Joshua Court, Spring Gully, Victoria, retired service engineer, deceased.

Creditors, next-of-kin and others having claims in respect of the estate of the deceased, who died on 27 December 2014, are required by Paula Ann Duce, the executor of the Will of the deceased, to send particulars of their claims to

her, care of the undermentioned address, by 4 September 2015, after which date the executor may convey or distribute the assets, having regard only to the claims of which she then has notice.

J. A. MIDDLEMIS, barrister and solicitor,
30 Myers Street, Bendigo, Victoria 3550.

ALISON RAIE CARLSON, late of BlueCross Hansworth, 181 Hansworth Street, Mulgrave, Victoria 3170, retired, deceased.

Creditors, next-of-kin and all others having claims in respect of the estate of the deceased, who died on 14 January 2015, are required by the executor, Christine Olivia Wallis, to send particulars of such claims to the executor, care of the undermentioned solicitors, within 60 days from the publication hereof, after which date the executor will distribute the assets, having regard only to the claims of which the executor has notice.

KLIGER PARTNERS LAWYERS,
Level 2, 280 Queen Street, Melbourne 3000.

RICHARD JAMES POWELL, late of 7 Wood Street, Warracknabeal, Victoria 3393, retired mechanic, deceased.

Creditors, next-of-kin and others having claims in respect of the abovenamed deceased, who died on 1 October 2012, are required by the executrix, Lynette Nash, to send claim particulars to Post Office Box 711, Mornington, Victoria 3931, by 24 August 2015, after which date assets will be distributed, having regard only to claims of which the executrix has notice.

Re: Estate of SHIRLEY JOY McPAUL, late of Waldreas Village, 211–217 Wantirna Road, Ringwood, deceased.

Creditors, next-of-kin and others having claims in respect of the estate of the deceased, who died on 30 March 2015, are required by the trustees to send particulars to the trustees, care of the undermentioned solicitors, by 25 September 2015, after which date the trustees may convey or distribute the assets, having regard only to the claims of which the trustees then have notice.

MAHONS with Yuncken & Yuncken, solicitors,
177 Surrey Road, Blackburn 3130.
SM:CH2150723

JOHN ALLAN RUSSELL, late of Colbran Nursing Home, 45 Moubray Street, Melbourne, retired, deceased.

Creditors, next-of-kin and others having claims in respect of the estate of the deceased, who died on 11 July 2014, are required by the trustees, Lynne Michelle Dryden and Mark James Dryden, to send particulars of their claims to the trustees, care of the undermentioned legal practitioners, by 30 August 2015, after which date the trustees may convey or distribute the assets, having regard only to the claims of which they then have notice.

PHILLIP BING & ASSOCIATES, lawyers,
Level 7, 470 Collins Street, Melbourne,
Victoria 3000.

Re: CHRISTOPHER ANDREW MUNDAY, deceased.

Creditors, next-of-kin and others having claims in respect of the estate of the deceased, who died on 16 February 2015, are required by the trustees, Nola June Taylor, Anna Guerra and Fiorenzo Guerra, care of Portelli & Co., solicitors, of 127 Carinish Road, Clayton, Victoria 3168, to send particulars to the trustees by 20 August 2015, after which date the trustees may convey or distribute the assets, having regard only to the claims of which the trustees have notice.

PORTELLI & CO., solicitors,
127 Carinish Road, Clayton 3168.

ANNA DE NARDO, late of 6 Hamilton Street, Brunswick West, home duties.

Creditors, next-of-kin and all others having claims in respect of the deceased, who died on 5 September 2014, are required by the executor, Rudolfo De Nardo of Level 1, 280 Spencer Street, Melbourne, to send particulars of such claims to the said executor by 4 November 2015, after which date the executor will distribute the assets, having regard only to the claims of which he has notice.

Dated 16 June 2015

Re: PERRY JOHN DEVERY, late of 71 Wurrook Circuit, North Geelong, Victoria, boiler maker, deceased.

Creditors, next-of-kin and others having claims in respect of the estate of the deceased, who died on 13 January 2015, are required by the trustee, Sandhurst Trustees Limited, ACN 004

030 737, of 18 View Street, Bendigo, Victoria, to send particulars to the trustee by 19 August 2015, after which date the trustee may convey or distribute the assets, having regard only to the claims of which the trustee then has notice.

SANDHURST TRUSTEES LIMITED,
18 View Street, Bendigo 3550.

Creditors, next-of-kin and others having claims in respect of the estate of IVICA MATANOVIC, also known as Ivan Matanovic, deceased intestate, late of 53/12 Pecks Road, Sydenham, truck driver, who died on 27 February 2015, are requested to send particulars of their claims to the administrators, Melissa Pace and Renee-Marie Matanovic, care of the undersigned solicitors, by 28 August 2015, after which date they will convey or distribute the assets, having regard only to the claims of which they then have notice.

SLATER & GORDON, solicitors,
100 Paisley Street, Footscray 3011.

NELLIE EVELYN REYNOLDS, late of 23 Forest Drive, Frankston North, Victoria, deceased.

Creditors, next-of-kin and others having claims in respect of the estate of the deceased, who died on 25 February 2015, are required by the executors, Jillian Helen Keleher of 117 Fleetwood Crescent, Frankston South, Victoria, and Robert George Dupas of 17 Allchin Avenue, Mornington, Victoria, to send particulars to them, care of Stidston Warren Lawyers, by 30 August 2015, after which date the executors may convey or distribute the assets, having regard only to the claims of which they then have notice.

STIDSTON WARREN LAWYERS,
Suite 1, 10 Blamey Place, Mornington 3931.

JOYCE THELMA LISTER, late of 27 Shierlaw Avenue, Canterbury, deceased.

Creditors, next-of-kin and others having claims in respect of the estate of the abovenamed deceased, who died on 8 April 2015, are required to send particulars of their claims to the executor, Grantley John Lister, care of the undermentioned solicitors, within 60 days from the date of publication of this notice, after which

date the said executor will distribute the assets, having regard only to the claims of which he then has notice.

T. J. MULVANY & CO., lawyers,
Suite 5.01, Level 5, 45 William Street,
Melbourne 3000.

JUNE ANN MULLER, late of 175 Belford Road, Kew East, deceased.

Creditors, next-of-kin and others having claims in respect of the estate of the abovenamed deceased, who died on 17 June 2014, are required to send particulars of their claims to the executors, Francis George Muller and Andrea Nanette Irwin, care of the undermentioned solicitors, within 60 days from the date of publication of this notice, after which date the said executors will distribute the assets, having regard only to the claims of which they then have notice.

T. J. MULVANY & CO., lawyers,
Suite 5.01, Level 5, 45 William Street,
Melbourne 3000.

Re: Estate of WILLIAM HENRY GRIFFITHS.

Creditors, next-of-kin and others having claims in respect of the estate of WILLIAM HENRY GRIFFITHS, deceased, late of 18 Upper Coonara Road, Olinda, Victoria, who died on 15 April 2014, are required to send particulars of such claims to the administrator, Dianne Helen Zwiers, care of the undermentioned solicitor, by 25 August 2015, after which date the administrator may convey or distribute the assets, having regard only to the claims of which the administrator then has notice.

TERENCE McMULLAN, solicitor,
40 Moores Road, Monbulk, Victoria 3793.

Re: Estate of ARTHUR LESLIE NEWNHAM.

Creditors, next-of-kin and others having claims in respect of the estate of ARTHUR LESLIE NEWNHAM, deceased, late of 107 Andersons Creek Road, East Doncaster, Victoria, who died on 23 October 2014, are required to send particulars of such claims to the executor, Leonie Jill Kitchen, care of the

undermentioned solicitor, by 25 August 2015, after which date the executor may convey or distribute the assets, having regard only to the claims of which the executor then has notice.

TERENCE McMULLAN, solicitor,
40 Moores Road, Monbulk, Victoria 3793.

Re: AUDREY JOAN THOMAS, late of BlueCross Scotchmans Creek, 450 Waverley Road, Mount Waverley, Victoria 3149, widow, deceased.

Creditors, next-of-kin and others having claims in respect of the estate of the deceased, who died on 22 April 2015, are required by the executors, Garry Colin Thomas and Kenneth Wayne Thomas, to send particulars to them, care of the undermentioned solicitors, by 28 August 2015, after which date the executors may convey and distribute the assets, having regard only to the claims of which they then have notice.

TRAGEAR & HARRIS LAWYERS,
1/23 Melrose Street, Sandringham 3191.

MICHAEL JEKIC, late of 134 Central Avenue, Altona Meadows, Victoria 3028, storeman, deceased.

Creditors, next-of-kin and others having claims in respect of the estate of the abovenamed deceased, who died on 28 March 2014, are required by the administrator, Michael Talent, care of 43 Ferguson Street, Williamstown, Victoria 3016, to send particulars of their claims to him by 25 August 2015, after which date the administrator may convey or distribute the assets and distribute the estate, having regard only to the claims of which he then has notice. Letters of Administration were granted in Victoria on 20 April 2015.

WILCKENS ROCHE LAWYERS, lawyers,
43 Ferguson Street, Williamstown, Victoria 3016,
PO Box 18, Williamstown, Victoria 3016,
Ph: 03 8383 5999, Fax: 03 8383 5900.

Re: The estate of VANESSA JANE JESSOP, late of 11/8 Robert Street, Elwood, Victoria.

Creditors, next-of-kin and others having claims in respect of the estate of the deceased, who died on 14 December 2014, are required by the administrators, Robert Eric Jessop and

Diane Fay Jessop, to send particulars to them, care of the undersigned solicitors, by 27 August 2015, after which date the trustee may convey or distribute the assets, having regard only to the claims of which the trustee has notice.

WILLIS SIMMONDS LAWYERS,
legal practitioners,
6/1 North Concourse, Beaumaris 3193.

RHODA ELIZABETH PAIGE, deceased.

Creditors, next-of-kin and others having claims in respect of the estate of the late RHODA ELIZABETH PAIGE, deceased, late of 18 Montclair Avenue, Brighton, Victoria, retired, deceased, who died on 16 November 2014, are required to send particulars of their claims to the executors, care of the undermentioned solicitor, by 25 August 2015, after which date the executors will proceed to distribute the assets, having regard only to the claims of which they shall then have had notice.

WILLS & WEALTH, solicitors,
19 Carpenter Street, Brighton 3186.

CROMWELL GEORGE BRAY, late of 2/31 James Street, Pakenham, Victoria, deceased.

Creditors, next-of-kin and others having claims in respect of the estate of the abovenamed deceased, who died on 8 March 2015, are required by the executor, Thomas Patrick Dominic Conway, care of Wollerman Shacklock Lawyers of 8 Gloucester Avenue, Berwick, Victoria 3806, to send particulars of their claims to them by 28 August 2015, after which date the executors may convey or distribute the assets and distribute the estate, having regard only to the claims of which they then have notice. Probate was granted in Victoria on 21 May 2015.

WOLLERMAN SHACKLOCK LAWYERS,
8 Gloucester Avenue, Berwick 3806.

ADVERTISEMENT OF AUCTION BY THE SHERIFF

Without Reserve Price, Sale is Subject to Approval of the Supreme Court of Victoria

On Thursday 30 July 2015 at 1.30 pm in the afternoon at the Sheriff's Office, 444 Swanston Street, Carlton (unless process be stayed or satisfied).

All the estate and interest (if any) of Mark Stephen Smythe of 8 Strathford Street, Epping, sole proprietor of an estate in fee simple in the land described on Certificate of Title Volume 09536 Folio 236, upon which is erected a house and known as 8 Strathford Street, Epping, will be auctioned by the Sheriff.

Registered Mortgage (Dealing Number X450500P), Registered Mortgage (Dealing Number AH582850S) and Registered Caveat (Dealing Number AK015926B) affect the said estate and interest. The Sheriff is unable to provide access to this property.

Terms: 10% deposit on the fall of the hammer. Balance within 7 days of the Court Approval. Payment is by cheque only.

Please contact Sheriff's Asset Administration Services by email at realestatesection@justice.vic.gov.au for an information sheet on Sheriff's auctions, a contract of sale and any other enquiries.

SHERIFF

ADVERTISEMENT OF AUCTION BY THE SHERIFF

On Thursday 30 July 2015 at 1.30 pm in the afternoon at the Sheriff's Office, 444 Swanston Street, Carlton (unless process be stayed or satisfied).

All the estate and interest (if any) of Stephen Carl Perryman and Benjie Perryman of Unit 210, 89-93 High Street South, Kew, joint proprietors of an estate in fee simple in the land described on Certificate of Title Volume 10383 Folio 666, upon which is erected a commercial suite and known as Unit 210, 89-93 High Street South, Kew, will be auctioned by the Sheriff.

Owners Corporation Plan No. PS410718P affects the said estate and interest.

The Sheriff is unable to provide access to this property.

Terms: 10% deposit on the fall of the hammer. Balance within 14 days unless as stated in particulars of sale in contract of sale. Payment is by cheque only.

Please contact Sheriff's Asset Administration Services by email at realestatesection@justice.vic.gov.au for an information sheet on Sheriff's auctions, a contract of sale and any other enquiries.

SHERIFF

ADVERTISEMENT OF AUCTION BY
THE SHERIFF

On Thursday 30 July 2015 at 1.30 pm in the afternoon at the Sheriff's Office, 444 Swanston Street, Carlton (unless process be stayed or satisfied).

All the estate and interest (if any) of Baljinder Singh of 1/33 King Edward Avenue, Albion, sole proprietor of an estate in fee simple in the land described on Certificate of Title Volume 10872 Folio 856, upon which is erected a house and known as 16 Tahlee Road, Tarneit, will be auctioned by the Sheriff.

Registered Mortgage (Dealing Number AH011971T) and Covenant PS524724J affect the said estate and interest.

The Sheriff is unable to provide access to this property.

Terms: 10% deposit on the fall of the hammer. Balance within 14 days unless as stated in particulars of sale in contract of sale. Payment is by cheque only.

Please contact Sheriff's Asset Administration Services by email at realestatesection@justice.vic.gov.au for an information sheet on Sheriff's auctions, a contract of sale and any other enquiries.

SHERIFF

ADVERTISEMENT OF AUCTION BY
THE SHERIFF

On Thursday 30 July 2015 at 1.30 pm in the afternoon at the Sheriff's Office, 444 Swanston Street, Carlton (unless process be stayed or satisfied).

All the estate and interest (if any) of Johannes Hendrikus Petrus Smit of 46 Ahern Road, Pakenham, joint proprietor with Lisette Anne Smit of an estate in fee simple in the following properties:

Firstly: Certificate of Title Volume 09197 Folio 262 upon which is erected a residential home and known as 46 Ahern Road, Pakenham, will be auctioned by the Sheriff.

Registered Mortgage (Dealing Number AE437402L) and Registered Caveat (Dealing Number AK632061V) affect the said estate and interest.

Terms: 10% deposit on the fall of the hammer. Balance within 14 days unless as stated in particulars of sale in contract of sale. Payment is by cheque only.

The Sheriff is unable to provide access to this property.

Secondly: Certificate of Title Volume 10739 Folio 782 and Volume 10739 Folio 784 upon which is erected units and known as Unit 6 and Unit 8, 35-41 Henry Street, Pakenham.

Registered Mortgage (Dealing Number AC580848H), Registered Caveat (Dealing Number AK632061V) and Owners Corporation 1 Plan No. PS507879Y affect the said estate and interest.

Terms: 10% deposit on the fall of the hammer. Balance within 14 days unless as stated in particulars of sale in contract of sale. Payment is by cheque only.

The Sheriff is unable to provide access to this property.

Note: Both units will be auctioned as one (1) Lot.

Thirdly: Certificate of Title Volume 10383 Folio 047 consisting of 4.042 hectares or thereabouts upon which is erected a residential home and known as 35 Granite Lane, Tynong.

Registered Mortgage (Dealing Number AD704883M) and Registered Caveat (Dealing Number AK632061V) affect the said estate and interest.

Terms: 10% deposit on the fall of the hammer. Balance within 14 days unless as stated in particulars of sale in contract of sale. Payment is by cheque only.

The Sheriff is unable to provide access to this property.

Please contact Sheriff's Asset Administration Services by email at realestatesection@justice.vic.gov.au for an information sheet on Sheriff's auctions, a contract of sale and any other enquiries.

SHERIFF

**GOVERNMENT AND OUTER BUDGET
SECTOR AGENCIES NOTICES**

MOUNT ALEXANDER SHIRE COUNCIL

Road Discontinuance

Pursuant to section 206 and Schedule 10, Clause 3 of the **Local Government Act 1989**, the Mount Alexander Shire Council, at its meeting on 28 April 2015 formed the opinion that the section of roads abutting Dannihers Lane, Metcalfe East, shown hatched on the plan below and more particularly described as Road R1 and Road R2 on Plan of Subdivision PS 419375U and more particularly described in Certificates of Title Volume 10583 Folios 525 and 526, are not reasonably required as roads for public use and resolved to discontinue the roads and sell the land to the abutting owner.

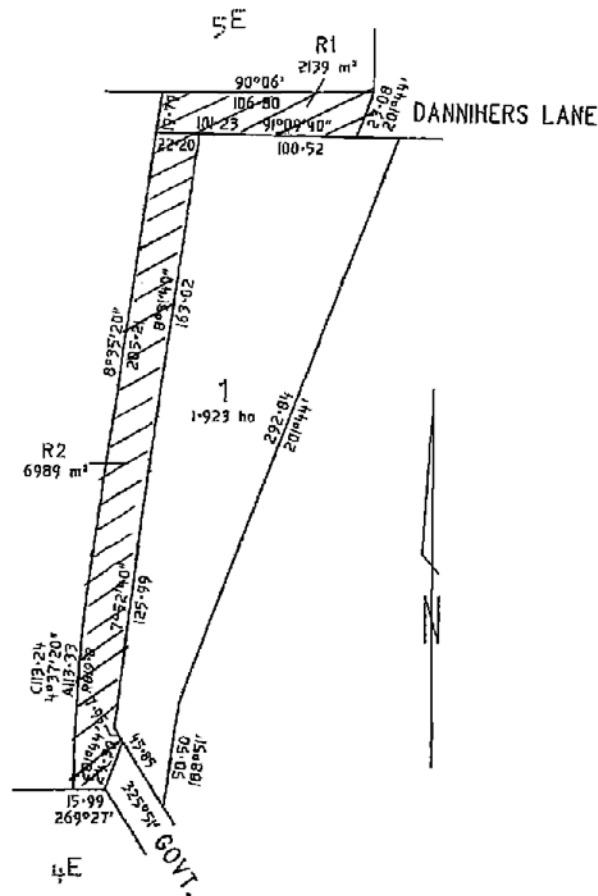

PHILIP JULIAN ROWLAND
Chief Executive Officer

CARDINIA SHIRE COUNCIL

Environment, Amenity and Asset Protection Local Law

Notice is hereby given that the Cardinia Shire Council, at its meeting held on 15 June 2015, resolved to make Local Law 17, Environment, Amenity and Asset Protection Local Law.

The purposes and general purport of the Local Law are to:

- provide for the peace, order and good government of the Cardinia Shire Council;
- promote a physical and social environment in the municipal district free from hazards to health and safety and to prevent and suppress nuisances which may adversely affect persons;
- prohibit, regulate and control activities which may be dangerous or unsafe or detrimental to the quality of life, the environment and the amenity of the municipality;
- prohibit, regulate and control access to and behaviour in municipal places, buildings, recreation centres and reserves and to protect public assets vested in Council;
- define the standards to which persons engaged in building work should adhere, which aims to minimise the impact of building activities in respect of hazards to health and safety, the presence and disposal of builders refuse, rubbish and soil, stormwater and other pollution; and
- provide for the consistent application and enforcement of this Local Law.

Copies of the Local Law can be obtained from the Cardinia Shire Council Offices, Siding Avenue, Officer, or by contacting Customer Service on 1300 787 624. The Local Law also appears on Council's website at www.cardinia.vic.gov.au

DAREBIN CITY COUNCIL

Public Notice

General Local Law No. 1 2015

Local Government Act 1989

Section 119(3)

On 16 June 2015, Darebin City Council adopted a new Local Law known as the Darebin City Council 'General Local Law No. 1 of 2015'. The new Local Law comes into operation on 1 July 2015.

Purpose of the General Local Law

The purpose of the General Local Law is to:

- (1) regulate and control uses and activities on Council land and roads so that the Council is aware of uses or activities which may:
 - (a) be detrimental to the amenity of the area or the enjoyment of facilities on land or roads;
 - (b) cause damage to Council and community assets;
 - (c) create a danger or expose others to risk;
 - (d) interfere with the safety and convenience of people travelling on or using Council land or roads; and
 - (e) impede free and safe access for people, in particular those with sight and movement impairment or disabilities;
- (2) manage, regulate and control activities and uses on any land which:
 - (a) may be dangerous, cause a nuisance or be detrimental to the amenity of the area or the environment;
 - (b) are directed at maintaining neighbourhood harmony and a healthy and safe environment for residents and visitors;

- (c) promotes community expectations and demands about their lifestyle and the availability of goods and services provided to them; and
 - (d) creates a sense of community pride in the Municipal District and which promotes Darebin City as a place to live and do business;
- (3) identify activities and uses that are not permitted so as to achieve the purposes in subclauses (1) and (2); and
- (4) provide for the administration of the Council's powers and functions so that they can be applied, having regard to the objectives in subclauses (1) and (2), in a fair and practicable way.

General Purport of the Local Law

The General Local Law will achieve its purpose by a number of measures including:

- prescribing uses and activities that will require a permit such as using a footpath for outdoor dining and displays of goods, undertaking any commercial activity on Council land or roads including commercial recreation uses, food trucks, fundraising, street parties, festivals or events, placing temporary advertising signs on Council land or roads, using Council roads for works, planting on nature strips, keeping excess numbers of animals, carrying out building works, and camping on Council land;
- identifying uses and activities which must comply with conditions or requirements in the Local Law including, in some instances, compliance with Council Policies, such as requirements applying to keeping animals or animal management in public places, requirements on owners or occupiers of commercial premises, the use of Council land, numbering properties and waste collection;
- designating areas where certain activities and uses may be carried out or not carried out, such as the location for food trucks, 'smoke-free areas' and 'alcohol-free zones';
- identifying uses and activities that are prohibited in certain circumstances such as allowing land or buildings to be kept in a way that is unsightly or detrimental to the general character and amenity of the neighbourhood or that could be a danger or a risk to people or property in the vicinity, behaving on Council land or on a road in a way that could harm or injure another person or which interferes with another person's reasonable enjoyment of that land or which could damage Council and community assets; and
- providing for the administration and enforcement of the Local Law through a permit system, creating appeal and representation rights and prescribing offences for contravention of certain provisions in the Local Law.

A copy of the General Local Law No. 1 2015 may be inspected at or obtained from Council Customer Service Centres during business hours (8.30 am to 5.00 pm Monday to Friday) or can be viewed on the Council's website at www.darebin.vic.gov.au

RASIAH DEV
Chief Executive Officer

LATROBE CITY COUNCIL

Local Law No. 2

Notice is hereby given that Latrobe City Council has resolved at its Ordinary Council meeting on 11 June 2015 the amendment to Local Law No. 2 in accordance with sections 111 and 119 of the **Local Government Act 1989**.

The Local Law is titled 'Latrobe City Council, Local Law No. 2'.

This amendment to the Local Law provides Council additional powers to make it an offence for owners or occupiers of land to permit building and other structures on that land to become dilapidated or a security or public safety or welfare risk.

The amendment to the Local Law will make it an offence for an owner or occupier of land on which there is a building or other structure which is unoccupied, unfit for occupation or not ordinarily occupied to:

- permit that building or structure to become dilapidated or further dilapidated;
- fail to take all reasonable steps to secure the building or structure from unauthorised access;
- fail to take all reasonable steps to prevent or remedy the land from being a haven for regular anti-social or unlawful behaviour by unauthorised persons;
- not maintain the building or structure in a state of good repair and appearance; or
- allow any graffiti to remain on any building, wall, fence, post or other structure or object erected on that land.

The Local Law comes into operation on the day following this gazettal.

Copies of the Local Law No. 2 are available for viewing during office hours at the Traralgon, Morwell and Moe Service Centres of Latrobe City Council. The Local Law No. 2 is also available on Latrobe City Council's website at www.latrobe.vic.gov.au

If you require any further information about the Local Law No. 2 you may contact Coordinator Local Laws, Stacey Jennings, on 5128 5750 or email stacey.jennings@latrobe.vic.gov.au

GARY VAN DRIEL
Chief Executive Officer

Planning and Environment Act 1987

DAREBIN PLANNING SCHEME

Notice of Preparation of Amendment

Amendment C148

Authorisation Number AO3073

Darebin City Council has prepared Amendment C148 to the Darebin Planning Scheme.

The Amendment applies to all land in the City of Darebin.

The Amendment proposes to extend the expired Darebin Development Contributions Plan 2004 (DCP), which ceased collecting funds

in June 2014. The extension of time enables the expenditure of surplus funds, in a manner that maximises community need and benefit.

The Amendment is consistent with section 46Q(4) of the **Planning and Environment Act 1987**, which outlines Council's obligations in circumstances where a DCP ends in surplus. Specifically, the Amendment:

- amends Schedule 1 to the Development Contributions Plan Overlay (DCPO1);
- amends the Incorporated Document 'City of Darebin Development Contributions Plan, June 2004'; and
- amends the list of incorporated documents at Clause 81.01 of the Darebin Planning Scheme to reflect the amended name of the DCP as 'City of Darebin Development Contributions Plan, June 2004 (Revised 2015)'.

You may inspect the Amendment, any documents that support the Amendment and the explanatory report about the Amendment, free of charge, at the following locations: during office hours, at the office of the planning authority, Darebin City Council, Level 1, 274 Gower Street, Preston 3072; and at the Department of Environment, Land, Water and Planning website: www.dtpli.vic.gov.au/publicinspection

Any person who may be affected by the Amendment may make a submission to the planning authority. Submissions must be made in writing giving the submitter's name and contact address, clearly stating the grounds on which the Amendment is supported or opposed and indicating what changes (if any) the submitter wishes to make. Name and contact details of submitters are required for Council to consider submissions and to notify such persons of the opportunity to attend Council meetings and any public hearing held to consider submissions. In accordance with the **Planning and Environment Act 1987**, Council must make available for inspection a copy of any submissions made.

The closing date for submissions is 27 July 2015.

A submission must be sent to the Coordinator, Strategic Planning, Darebin City Council, PO Box 91, Preston, Victoria 3072. You can also lodge a submission via email to planningservices@darebin.vic.gov.au

The following panel hearing dates have been set for this Amendment:

- Directions hearing: week of 19 October 2015.
- Panel hearing: week of 9 November 2015.

RASIAH DEV
Chief Executive Officer

Planning and Environment Act 1987

MONASH PLANNING SCHEME

Notice of Preparation of Amendment Amendment C120

Monash City Council has prepared Amendment C120 to the Monash Planning Scheme.

The Amendment applies to land located within the Glen Waverley Activity Centre, an area generally bounded by High Street Road to the north, Springvale Road to the east (however including properties to the east of Springvale Road), Wilson Street and Lincoln Avenue to the south and Riley Court, Kinnoull Grove and Rose Avenue to the west.

The Amendment proposes to implement the Glen Waverley Activity Centre Structure Plan and change the existing planning provisions to encourage the ongoing development of the Activity Centre in accordance with the Structure Plan adopted by Council in 2014.

The changes proposed by the Amendment are designed to strengthen the area as the region's premier food and entertainment precinct, identify opportunities for more diverse housing options, and strengthen the medical precinct emerging on the western side of Springvale Road.

The proposed changes include:

- the introduction of a Residential Growth Zone and new General Residential Zones to discrete areas adjacent to the commercial areas of the Activity Centre;
- the introduction of a Design and Development Overlay to provide clear guidance on preferred building height and form throughout the Activity Centre and measures to protect amenity for traders and residents;
- changes to the local policies to reflect the Structure Plan; and
- making the Glen Waverley Activity Structure Plan 2014 a reference document in the Monash Planning Scheme.

You may inspect the Amendment, any documents that support the Amendment and the explanatory report about the Amendment, free of charge: during office hours, at the offices of Monash Council (the planning authority): Monash Civic Centre (293 Springvale Road, Glen Waverley); Oakleigh Service Centre (3 Atherton Road); all Monash library branches; on Council's website: www.monash.vic.gov.au/haveyoursay; and on the Department of Environment, Land, Water and Planning's website: www.dtpli.vic.gov.au/publicinspection

Any person who may be affected by the Amendment may make a submission to Council (the planning authority). Submissions must be made in writing, and you must provide your name and contact address. Please clearly state the grounds on which the Amendment is supported or opposed and indicate what changes (if any) you would like to see made.

Council requires the names and contact details of submitters so we can consider submissions and notify submitters of the opportunity to attend Council meetings and any public hearings held to consider submissions. In accordance with the **Planning and Environment Act 1987**, Council must make available for inspection a copy of any submissions made.

The closing date for submissions is 31 August 2015. Submissions can be sent to: via mail: Amendment C120, Monash Council, PO Box 1, Glen Waverley 3150; and via email: mail@monash.vic.gov.au

The following panel hearing dates have been proposed for this Amendment:

- Directions hearing: week of 9 November 2015.
- Panel hearing: week of 7 December 2015.

If you have any questions or would like to discuss this matter, please call Sean McNamee, Coordinator Strategic Planning, on 9518 3229.

ANDI DIAMOND
Chief Executive Officer
Monash City Council

Planning and Environment Act 1987

MONASH PLANNING SCHEME

Notice of Preparation of Amendment Amendment C125

Monash City Council has prepared Amendment C125 to the Monash Planning Scheme.

The Amendment applies generally to land throughout the City of Monash that is currently in the General Residential Zone and the Neighbourhood Residential Zone.

The Amendment proposes to introduce the Monash Housing Strategy 2014 within the Monash Planning Scheme as a reference document, and updates the local planning policy framework to reflect the objectives and actions within the strategy.

It updates and introduces new schedules to the General Residential and Neighbourhood Residential Zones and modifies the boundaries of these zones to reflect the Residential Framework Plan contained in the Monash Housing Strategy 2014.

It also introduces changes to land included in the General Residential Zone which is located in the Monash National Employment Cluster, in order to support State Government objectives articulated in Plan Melbourne: Metropolitan Planning Strategy.

The Amendment also proposes to introduce specific changes to support and respond to increased residential development opportunities by:

- applying Design and Development Overlay 13 to areas proposed for increased residential development in the Clayton Activity Centre and the residential areas of Monash National Employment Cluster;
- applying Development Contribution Plan Overlay Number 1 to land within the Clayton Activity Centre and the residential areas of Monash National Employment Cluster; and
- increasing the Public Open Space contribution of Clause 52.01 to 10% for land within the Clayton Activity Centre and the Monash National Employment Cluster.

You may inspect the Amendment, any documents that support the Amendment and the explanatory report about the Amendment, free of charge, during office hours, at: Monash Civic Centre (293 Springvale Road, Glen Waverley); Oakleigh Service Centre (3 Atherton Road); all Monash library branches; on Council's website: www.monash.vic.gov.au/haveyoursay; and on the Department of Environment, Land, Water and Planning's website: www.dtpli.vic.gov.au/publicinspection

Any person who may be affected by the Amendment may make a submission to Council (the planning authority). Submissions must be made in writing, and you must provide your name and contact address. Please clearly state the grounds on which the Amendment is supported or opposed and indicate what changes (if any) you would like to see made.

Council requires the names and contact details of submitters so we can consider submissions and notify submitters of the opportunity to attend Council meetings and any public hearings held to consider submissions. In accordance with the **Planning and Environment Act 1987**, Council must make available for inspection a copy of any submissions made.

The closing date for submissions is 31 August 2015. Submissions can be sent: via mail: Amendment C125, Monash Council, PO Box 1, Glen Waverley 3150; and via email: mail@monash.vic.gov.au

The following panel hearing dates have been proposed for this Amendment:

- Directions hearing: week of 9 November 2015.
- Panel hearing: week of 7 December 2015.

If you have any questions or would like to discuss this matter, please call Sean McNamee, Coordinator Strategic Planning, on 9518 3229.

ANDI DIAMOND
Chief Executive Officer
Monash City Council

Planning and Environment Act 1987

MOUNT ALEXANDER PLANNING SCHEME

Notice of Preparation of Amendment Amendment C60

The Mount Alexander Shire Council has prepared Amendment C60 to the Mount Alexander Planning Scheme.

The land affected by the Amendment lies along Forest Street from Kennedy Street to Urquhart Street; and along Forest Creek (including the stone creek channel), including properties in Bruce Street and Barker Street, south of the intersection on Forest Street.

The Amendment proposes to apply the Heritage Overlay to two Precincts and one Heritage Serial Site (comprising 15 individual places) along Forest Creek in Castlemaine.

You may inspect the Amendment, any documents that support the Amendment and the explanatory report about the Amendment, free of charge, at the following locations: during office hours, at the office of the planning authority, Mount Alexander Shire Council, 27 Lyttleton Street, Castlemaine 3450; and at the Department of Environment, Land, Water and Planning website, www.dtpli.vic.gov.au/publicinspection

Any person who may be affected by the Amendment may make a submission to the planning authority. Submissions must be made in writing giving the submitter's name and contact address, clearly stating the grounds on which the Amendment is supported or opposed and indicating what changes (if any) the submitter wishes to make.

Name and contact details of submitters are required for Council to consider submissions and to notify such persons of the opportunity to attend Council meetings and any public hearing held to consider submissions. In accordance with the **Planning and Environment Act 1987**, Council must make available for inspection a copy of any submissions made.

The closing date for submissions is Monday 10 August 2015. A submission must be sent to the Mount Alexander Shire Council, PO Box 185, Castlemaine, Victoria 3450.

The following panel hearing dates have been set for this amendment:

- Directions hearing: week commencing 19 October 2015.
- Panel hearing: week commencing 16 November 2015.

PHIL ROWLAND
Chief Executive Officer

Planning and Environment Act 1987
WELLINGTON PLANNING SCHEME
Notice of Preparation of Amendment
Amendment C95

The Wellington Shire Council has prepared Amendment C95 to the Wellington Planning Scheme.

The land affected by the Amendment is all land in Port Albert and its immediate surroundings.

The Amendment proposes to implement the recommendations of the Port Albert Planning Controls Review (June 2014) and the Port Albert Rural Residential Lifestyle Lot Review (December 2014).

You may inspect the Amendment, any documents that support the Amendment and the explanatory report about the Amendment, free of charge, at the following locations: during office hours, at the office of the planning authority, Wellington Shire Council, 18 Desailly Street, Sale, and 156 Grant Street, Yarram; and at the Department of Environment, Land, Water and Planning website, www.dtpli.vic.gov.au/publicinspection

Any person who may be affected by the Amendment may make a submission to the planning authority. Submissions must be made in writing giving the submitter's name and contact address, clearly stating the grounds on which the Amendment is supported or opposed and indicating what changes (if any) the submitter wishes to make.

Name and contact details of submitters are required for Council to consider submissions and to notify such persons of the opportunity to attend Council meetings and any public hearing held to consider submissions. In accordance with the **Planning and Environment Act 1987**, Council must make available for inspection a copy of any submissions made.

The closing date for submissions is 27 July 2015. A submission must be sent to the Wellington Shire Council, PO Box 506, Sale, Victoria 3850.

DAVID MORCOM
Chief Executive Officer

Creditors, next-of-kin and others having claims against the estate of any of the undermentioned deceased persons are required to send particulars of their claims to State Trustees Limited, ABN 68 064 593 148, of 1 McNab Avenue, Footscray, Victoria 3011, the personal representative, on or before 26 August 2015, after which date State Trustees Limited may convey or distribute the assets, having regard only to the claims of which State Trustees Limited then has notice.

CHRISTOU, George, late of Allanvale Private Nursing Home, 38–40 Ascot Street, Altona Meadows, Victoria, deceased, who died on 18 January 2015.

SHERIDAN, Francis Michael, late of Jack Lonsdale Lodge, 232 Spencer Street, Sebastopol, Victoria, retired, deceased, who died on 10 January 2015. Grant of Probate dated 4 June 2015.

SODEN, Veda, late of Grace Villa Aged Care, 4/25 Grimshaw Street, Greensborough, Victoria, deceased, who died on 9 February 2015.

Dated 17 June 2015

STEWART MacLEOD
Manager

Creditors, next-of-kin and others having claims against the estate of any of the undermentioned deceased persons are required to send particulars of their claims to State Trustees Limited, ABN 68 064 593 148, of 1 McNab Avenue, Footscray, Victoria 3011, the personal representative, on or before 31 August 2015, after which date State Trustees Limited may convey or distribute the assets, having regard only to the claims of which State Trustees Limited then has notice.

CARPENTER, Jean Scott, late of Baptcare Westhaven Community, 50 Pickett Street, Footscray, Victoria, retired, deceased, who died on 21 March 2015.

MACDERMID, Maureen Frances, late of Unit 10, 15 Kenilworth Parade, Ivanhoe, Victoria, deceased, who died on 18 March 2015.

SELLARS, Stanley, late of Twin Parks Aged Care, 47 Blake Street, Reservoir, Victoria, retired, deceased, who died on 14 March 2015.

Dated 22 June 2015

STEWART MacLEOD
Manager

Creditors, next-of-kin and others having claims against the estate of any of the undermentioned deceased persons are required to send particulars of their claims to State Trustees Limited, ABN 68 064 593 148, of 1 McNab Avenue, Footscray, Victoria 3011, the personal representative, on or before 1 September 2015, after which date State Trustees Limited may

convey or distribute the assets, having regard only to the claims of which State Trustees Limited then has notice.

BENCZE, Jan, late of Claremont Home 288–294 Albert Road, South Melbourne, Victoria, retired, deceased, who died on 4 January 2015.

ROWE, Violet Jean, late of 1st Level, Darley House East – Centaur Building, Banksia Street, Heidelberg West, Victoria, deceased, who died on 7 December 2014.

Dated 23 June 2014

STEWART MacLEOD
Manager

Associations Incorporation Reform Act 2012 SUB-SECTION 138

I, David Joyner, Deputy Registrar of Incorporated Associations, under delegation provided by the Registrar, hereby give notice that an application for the voluntary cancellation of incorporation, pursuant to section 136 of the Act, has been received by the Registrar from each of the associations mentioned below:

West Heidelberg Community Legal Service Inc.; The Ouyen Theatre Group Inc.; Euroa Juniors Cricket Club Inc.; Just Soaring Inc.; Boyeo Public Hall Inc.; Australasian Professional Doula Regulatory Association Inc.; Corryong Branch Blue Light Disco Inc.; Bacchus Marsh Aero Association Inc.; All Generation Christian Fellowship Inc.; Wyuna Cricket Club Inc.; No East West Link Inc.; Tunstall Counselling and Resource Centre Inc.; Castlemaine Out of School Hours Care Inc.; Shark Defence Australia Inc.; Mallee Agricultural Research Foundation Inc.; Elizabeth Wilmot Pre-School Inc.; Jeparit and District Community Emergency Response Team Inc.; Sale Rifle Club Inc.; Simpson Dairy Farmers Employees Social Club Inc.; Subaru Dealers Association of Victoria Rural Division Inc.; Probus Club of Sandringham Inc.; Caulfield Combined Probus Club Inc.; Grovedale Community Craft Club Inc.; Bayside Sister Cities Association Inc.; West Meadows Heights Occasional Child Care Association Inc.; Koimishs Theotokou Polyplatanos Florinhs Inc.; Strictly Masters Inc.; Cardiac Eye International Foundation Inc.; Blackwood Special Schools Outdoor Education Centre Inc.; Mornington Peninsula Alpaca Breeders Inc.; Probus Club of Essendon City Inc.; Probus Club of Oakleigh Inc.; Centre for Faith Life and Learning Inc.;

Catchment Youth Services Inc.; The Missionaries of the Holy Face Inc.; Morongo Old Collegians Association Inc.; ACMEC Australia Inc.; The Alexandra Singers Inc.; Kyneton Amateur Swimming Club Inc.; The Orchard Warrandyte Inc.; Bairnsdale Equestrian Park Committee of Management Inc.; Easy Breathers (Vic) Inc.; Eagles Basketball Club Inc.; West Gippsland District Group of Australian Plant Society Inc.; Silver Sharks – Masters Swimming Inc.; Paynesville Angling Club Inc.; Carpenters Cross Ministries (Australia) Inc.; Japanese for Peace Inc.; Albanian Community School Inc.; Conical Contemporary Art Space Inc.; Shepparton Rockers Inc.

I further advise that unless a person makes a written objection to cancellation to the Registrar within 28 days of the date of this notice, I intend to cancel the incorporation of the incorporated associations mentioned above.

Dated 25 June 2015

DAVID JOYNER
Deputy Registrar of
Incorporated Associations
PO Box 4567
Melbourne, Victoria 3001

Associations Incorporation Reform Act 2012

SECTION 135

I, David Joyner, Deputy Registrar under the **Associations Incorporation Reform Act 2012** (the Act), under delegation provided by the Registrar, hereby give notice that, pursuant to section 135(3) of the Act, I intend to cancel the incorporation of the incorporated associations mentioned below:

Albion Cricket Club Inc.; D P Group Inc.; Filipino 4WD Association; Moorabbin Central Traders Association Inc.; Bendigo & District Servicemen's Club Inc.; Geminiani Chamber Orchestra Inc.

I further advise that unless a person makes a written objection to cancellation to the Registrar within 28 days of the date of this notice, I intend to cancel the incorporation of the incorporated associations mentioned above.

Dated 25 June 2015

DAVID JOYNER
Deputy Registrar of
Incorporated Associations
PO Box 4567
Melbourne, Victoria 3001

Co-operatives National Law (Victoria)

WANTIRNA SOUTH PRIMARY SCHOOL LIBRARY CO-OPERATIVE LTD

On application under section 601AB of the **Corporations Act 2001** (the Act), notice is hereby given under section 601AB(2) of the Act, as applied by section 453(a) of the **Co-operatives National Law (Victoria)**, that, at the expiration of two months from the date of this notice, the name of the co-operative listed above will, unless cause is shown to the contrary, be removed from the register of co-operatives and the registration will be dissolved.

Dated at Melbourne 25 June 2015

DAVID JOYNER
Deputy Registrar of Cooperatives

Cemeteries and Crematoria Act 2003

SECTION 41(1)

Notice of Approval of Cemetery Trust Fees and Charges

I, Bryan Crampton, as Delegate of the Secretary to the Department of Health and Human Services for the purposes of section 40(2) of the **Cemeteries and Crematoria Act 2003**, give notice that I have approved the scales of fees and charges fixed by the following cemetery trust/s.

The Greater Metropolitan Cemeteries Trust

The approved scales of fees and charges will take effect from the date of publication of this notice in the Government Gazette and will be published on the internet.

The fees will be published on the internet at <http://www.health.vic.gov.au/cemeteries> and will also be published on the cemetery trust website at <http://www.gmct.com.au>

Dated 17 June 2015

BRYAN CRAMPTON
Manager
Cemeteries and Crematoria Regulation Unit

Conservation, Forests and Lands Act 1987**NOTICE OF MAKING OF A LAND MANAGEMENT AGREEMENT**

Notice is given under section 80 of the **Conservation, Forests and Lands Act 1987** that the Secretary to the Department of Environment, Land, Water and Planning, as successor in law of the Secretary to the Department of Environment and Primary Industries, and B.J.K Nominees Pty Ltd have entered into an agreement to terminate a Farm Forestry Incentive Scheme Land Owner Agreement in respect of the land set out in the Schedule.

SCHEDULE

Site Location	Title Details Volume/Folio	Dealing No. of Agreement terminated
Lot 1 on TP 813087P Parish of Broadford	Volume 8850 Folio 074	AL614879J
Lot 1 on TP 813087P Parish of Broadford	Volume 8850 Folio 075	AL614879J
Lot 2 on PS 127251 Parish of Broadford	Volume 11020 Folio 255	AL614879J

NOTICE OF MAKING OF A LAND MANAGEMENT AGREEMENT

Notice is given under section 80 of the **Conservation, Forests and Lands Act 1987** that the Secretary to the Department of Environment, Land, Water and Planning, as successor in law of the Secretary to the Department of Environment and Primary Industries, and Johanna Petronella Barker and Ramon Charles Barker have entered into an agreement to terminate a Farm Forestry Incentive Scheme Land Owner Agreement in respect of the land set out in the Schedule.

SCHEDULE

Site Location	Title Details Volume/Folio	Dealing Number of Agreement terminated
Lot 8 on PS 144961 Parish of Wappon	Volume 9549 Folio 752	AL614910T

NOTICE OF MAKING OF A LAND MANAGEMENT AGREEMENT

Notice is given under section 80 of the **Conservation, Forests and Lands Act 1987** that the Secretary to the Department of Environment, Land, Water and Planning, as successor in law of the Secretary to the Department of Environment and Primary Industries, and Edward William Ross Barlow have entered into an agreement to terminate a Farm Forestry Incentive Scheme Land Owner Agreement in respect of the land set out in the Schedule.

SCHEDULE

Site Location	Title Details Volume/Folio	Dealing Number of Agreement terminated
Lot 1 on PS 347888M Parish of Warrenbayne	Volume 10301 Folio 245	AL614956S

NOTICE OF MAKING OF A LAND MANAGEMENT AGREEMENT

Notice is given under section 80 of the **Conservation, Forests and Lands Act 1987** that the Secretary to the Department of Environment, Land, Water and Planning, as successor in law of the Secretary to the Department of Environment and Primary Industries, and Bealach an Diorin Pty Ltd have entered into an agreement to terminate a Farm Forestry Incentive Scheme Land Owner Agreement in respect of the land set out in the Schedule.

SCHEDULE

Site Location	Title Details Volume/Folio	Dealing Number of Agreement terminated
Lot 1 on PS147627X Parish of Billian	Volume 9585 Folio 018	AL615175S

NOTICE OF MAKING OF A LAND MANAGEMENT AGREEMENT

Notice is given under section 80 of the **Conservation, Forests and Lands Act 1987** that the Secretary to the Department of Environment, Land, Water and Planning, as successor in law of the Secretary to the Department of Environment and Primary Industries, and Colin Campbell Bertuch and Elisa Margaret Bertuch have entered into an agreement to terminate a Farm Forestry Incentive Scheme Land Owner Agreement in respect of the land set out in the Schedule.

SCHEDULE

Site Location	Title Details Volume/Folio	Dealing Number of Agreement terminated
Lots 1, 2 and 3 on TP845345N Parish of Wandiligong	Volume 9771 Folio 580	AL615206J

NOTICE OF MAKING OF A LAND MANAGEMENT AGREEMENT

Notice is given under section 80 of the **Conservation, Forests and Lands Act 1987** that the Secretary to the Department of Environment, Land, Water and Planning, as successor in law of the Secretary to the Department of Environment and Primary Industries, and Bindah Pastoral Pty Ltd have entered into an agreement to terminate a Farm Forestry Incentive Scheme Land Owner Agreement in respect of the land set out in the Schedule.

SCHEDULE

Site Location	Title Details Volume/Folio	Dealing Number of Agreement terminated
Crown Allotment 15 Section C Parish of Borodomanin	Volume 6266 Folio 095	AL615208E
Crown Allotment 15 Section C Parish of Borodomanin	Volume 6266 Folio 095	AL615209C
Lot 2 on PS 513534B Parish of Borodomanin	Volume 10737 Folio 109	AL615210T

NOTICE OF MAKING OF A LAND MANAGEMENT AGREEMENT

Notice is given under section 80 of the **Conservation, Forests and Lands Act 1987** that the Secretary to the Department of Environment, Land, Water and Planning, as successor in law of the Secretary to the Department of Environment and Primary Industries, and Bristen Pty Ltd have entered into an agreement to terminate a Farm Forestry Incentive Scheme Land Owner Agreement in respect of the land set out in the Schedule.

SCHEDULE

Site Location	Title Details Volume/Folio	Dealing Number of Agreement terminated
Lot 4 PS 319744W Parish of Ghin Ghin	Volume 10339 Folio 364	AL615211R

NOTICE OF MAKING OF A LAND MANAGEMENT AGREEMENT

Notice is given under section 80 of the **Conservation, Forests and Lands Act 1987** that the Secretary to the Department of Environment, Land, Water and Planning, as successor in law of the Secretary to the Department of Environment and Primary Industries, and Charles Allan Brydon and Kathryn Helen Auty have entered into an agreement to terminate a Farm Forestry Incentive Scheme Land Owner Agreement in respect of the land set out in the Schedule.

SCHEDULE

Site Location	Title Details Volume/Folio	Dealing Number of Agreement terminated
Lot 2 on PS 318531V Parish of Marraweeny	Volume 10109 Folio 936	AL615212P

NOTICE OF MAKING OF A LAND MANAGEMENT AGREEMENT

Notice is given under section 80 of the **Conservation, Forests and Lands Act 1987** that the Secretary to the Department of Environment, Land, Water and Planning, as successor in law of the Secretary to the Department of Environment and Primary Industries, and Robert Philip Christopher have entered into an agreement to terminate a Farm Forestry Incentive Scheme Land Owner Agreement in respect of the land set out in the Schedule.

SCHEDULE

Site Location	Title Details Volume/Folio	Dealing Number of Agreement terminated
Lot 1 on TP 897131Q Parish of Taggerty Lot 2 on PS 134573 Parish of Taggerty	Volume 8566 Folio 390 Volume 9645 Folio 634	AL615213M AL615214K

NOTICE OF MAKING OF A LAND MANAGEMENT AGREEMENT

Notice is given under section 80 of the **Conservation, Forests and Lands Act 1987** that the Secretary to the Department of Environment, Land, Water and Planning, as successor in law of the Secretary to the Department of Environment and Primary Industries, and Roger Edward Clarke and Jacqueline Clarke have entered into an agreement to terminate a Farm Forestry Incentive Scheme Land Owner Agreement in respect of the land set out in the Schedule.

SCHEDULE

Site Location	Title Details Volume/Folio	Dealing Number of Agreement terminated
Lots 1, 2, 3 and 4 on TP 129926L Parish of Yea Crown Allotment 218B Parish of Yea Crown Allotment 214 & 215 Parish of Yea Crown Allotment 214C, Parish of Yea	Volume 9396 Folio 003 Volume 9493 Folio 837 Volume 8075 Folio 223 Volume 6644 Folio 622	AL615215H

NOTICE OF MAKING OF A LAND MANAGEMENT AGREEMENT

Notice is given under section 80 of the **Conservation, Forests and Lands Act 1987** that the Secretary to the Department of Environment, Land, Water and Planning, as successor in law of the Secretary to the Department of Environment and Primary Industries, and Richard Paul Champion De Crespigny have entered into an agreement to terminate a Farm Forestry Incentive Scheme Land Owner Agreement in respect of the land set out in the Schedule.

SCHEDULE

Site Location	Title Details Volume/Folio	Dealing Number of Agreement terminated
Lots 1 and 2 on TP 513626H Parish of Kelfeera	Volume 8916 Folio 192	AL615216F AL615217D

NOTICE OF MAKING OF A LAND MANAGEMENT AGREEMENT

Notice is given under section 80 of the **Conservation, Forests and Lands Act 1987** that the Secretary to the Department of Environment, Land, Water and Planning, as successor in law of the Secretary to the Department of Environment and Primary Industries, and Stephen John Delgos have entered into an agreement to terminate a Farm Forestry Incentive Scheme Land Owner Agreement in respect of the land set out in the Schedule.

SCHEDULE

Site Location	Title Details Volume/Folio	Dealing Number of Agreement terminated
Land in PC 172158D Parish of Tallangallook	Volume 9940 Folio 892	AL615218B

NOTICE OF MAKING OF A LAND MANAGEMENT AGREEMENT

Notice is given under section 80 of the **Conservation, Forests and Lands Act 1987** that the Secretary to the Department of Environment, Land, Water and Planning, as successor in law of the Secretary to the Department of Environment and Primary Industries, and Michael William Dexter and Georgina Catherine Arnold Dexter have entered into an agreement to terminate a Farm Forestry Incentive Scheme Land Owner Agreement in respect of the land set out in the Schedule.

SCHEDULE

Site Location	Title Details Volume/Folio	Dealing Number of Agreement terminated
Lot 5 on PS 317757X Parish of Alexandra	Volume 10204 Folio 760	AL615252B

NOTICE OF MAKING OF A LAND MANAGEMENT AGREEMENT

Notice is given under section 80 of the **Conservation, Forests and Lands Act 1987** that the Secretary to the Department of Environment, Land, Water and Planning, as successor in law of the Secretary to the Department of Environment and Primary Industries, and Warren Douglas Fern have entered into an agreement to terminate a Farm Forestry Incentive Scheme Land Owner Agreement in respect of the land set out in the Schedule.

SCHEDULE

Site Location	Title Details Volume/Folio	Dealing Number of Agreement terminated
Lot 4 on PS 703987C Parish of Switzerland	Volume 11368 Folio 771	AL615253Y

NOTICE OF MAKING OF A LAND MANAGEMENT AGREEMENT

Notice is given under section 80 of the **Conservation, Forests and Lands Act 1987** that the Secretary to the Department of Environment, Land, Water and Planning, as successor in law of the Secretary to the Department of Environment and Primary Industries, and Richard Lawrence Forrest and Jennifer Ruth Forrest have entered into an agreement to terminate a Farm Forestry Incentive Scheme Land Owner Agreement in respect of the land set out in the Schedule.

SCHEDULE

Site Location	Title Details Volume/Folio	Dealing Number of Agreement terminated
Plan of Consolidation 162193H Parish of Nillahcootie	Volume 9700 Folio 835	AL615254W
Lots 1, 2, 3, 4 and 5 on TP 384697W Parish of Nillahcootie	Volume 7959 Folio 132	

NOTICE OF MAKING OF A LAND MANAGEMENT AGREEMENT

Notice is given under section 80 of the **Conservation, Forests and Lands Act 1987** that the Secretary to the Department of Environment, Land, Water and Planning, as successor in law of the Secretary to the Department of Environment and Primary Industries, and Leonard Raymond Foster and Jennifer Anne Foster have entered into an agreement to terminate a Farm Forestry Incentive Scheme Land Owner Agreement in respect of the land set out in the Schedule.

SCHEDULE

Site Location	Title Details Volume/Folio	Dealing Number of Agreement terminated
Lot 1 on PS 713201Q Parish of Boorolite Lot 2 on PS 713201Q Parish of Boorolite	Volume 11456 Folio 208 Volume 11456 Folio 209	AL615255U

NOTICE OF MAKING OF A LAND MANAGEMENT AGREEMENT

Notice is given under section 80 of the **Conservation, Forests and Lands Act 1987** that the Secretary to the Department of Environment, Land, Water and Planning, as successor in law of the Secretary to the Department of Environment and Primary Industries, and Ivan Lindsay Fox have entered into an agreement to terminate a Farm Forestry Incentive Scheme Land Owner Agreement in respect of the land set out in the Schedule.

SCHEDULE

Site Location	Title Details Volume/Folio	Dealing Number of Agreement terminated
Lot 1 on TP 803733Q Parish of Yarck	Volume 8235 Folio 986	AL615257Q

NOTICE OF MAKING OF A LAND MANAGEMENT AGREEMENT

Notice is given under section 80 of the **Conservation, Forests and Lands Act 1987** that the Secretary to the Department of Environment, Land, Water and Planning, as successor in law of the Secretary to the Department of Environment and Primary Industries, and Geelong Grammar School have entered into an agreement to terminate a Farm Forestry Incentive Scheme Land Owner Agreement in respect of the land set out in the Schedule.

SCHEDULE

Site Location	Title Details Volume/Folio	Dealing Number of Agreement terminated
Lot 1 on TP 622284B Parish of Changue Crown Allotments 11 and 12 Section A Parish of Changue	Volume 9080 Folio 558 Volume 4505 Folio 974	AL615258N

NOTICE OF MAKING OF A LAND MANAGEMENT AGREEMENT

Notice is given under section 80 of the **Conservation, Forests and Lands Act 1987** that the Secretary to the Department of Environment, Land, Water and Planning, as successor in law of the Secretary to the Department of Environment and Primary Industries, and Gordon Master Pty Ltd have entered into an agreement to terminate a Farm Forestry Incentive Scheme Land Owner Agreement in respect of the land set out in the Schedule.

SCHEDULE

Site Location	Title Details Volume/Folio	Dealing Number of Agreement terminated
Crown Allotment 34 Parish of Rothesay Crown Allotment 42 Parish of Rothesay	Volume 10136 Folio 995 Volume 3546 Folio 110	AL615259L

NOTICE OF MAKING OF A LAND MANAGEMENT AGREEMENT

Notice is given under section 80 of the **Conservation, Forests and Lands Act 1987** that the Secretary to the Department of Environment, Land, Water and Planning, as successor in law of the Secretary to the Department of Environment and Primary Industries, and Great Alpine Ventures Pty Ltd have entered into an agreement to terminate a Farm Forestry Incentive Scheme Land Owner Agreement in respect of the land set out in the Schedule.

SCHEDULE

Site Location	Title Details Volume/Folio	Dealing Number of Agreement terminated
Lot 1 on TP213733E Parish of Barwidgee	Volume 9077 Folio 687	AL615261A

NOTICE OF MAKING OF A LAND MANAGEMENT AGREEMENT

Notice is given under section 80 of the **Conservation, Forests and Lands Act 1987** that the Secretary to the Department of Environment, Land, Water and Planning, as successor in law of the Secretary to the Department of Environment and Primary Industries, and Bridget Rose Hamilton and Ruben Mills Hamilton, in their capacity as Legal Personal Representatives of Gavin Alexander Hamilton have entered into an agreement to terminate a Farm Forestry Incentive Scheme Land Owner Agreement in respect of the land set out in the Schedule.

SCHEDULE

Site Location	Title Details Volume/Folio	Dealing Number of Agreement terminated
Crown Allotment 17 Section 4 Parish of Cudgewa Lot 1, 2 and 3 on TP 745481M Parish of Cudgewa	Volume 9000 Folio 924 Volume 7324 Folio 730	AL615262X

NOTICE OF MAKING OF A LAND MANAGEMENT AGREEMENT

Notice is given under section 80 of the **Conservation, Forests and Lands Act 1987** that the Secretary to the Department of Environment, Land, Water and Planning, as successor in law of the Secretary to the Department of Environment and Primary Industries, and Daryl Norman Jarvis have entered into an agreement to terminate a Farm Forestry Incentive Scheme Land Owner Agreement in respect of the land set out in the Schedule.

SCHEDULE

Site Location	Title Details Volume/Folio	Dealing Number of Agreement terminated
Lot 1, 2 and 3 on TP233799J Parish of Wabba	Volume 4131 Folio 059	AL615263V

NOTICE OF MAKING OF A LAND MANAGEMENT AGREEMENT

Notice is given under section 80 of the **Conservation, Forests and Lands Act 1987** that the Secretary to the Department of Environment, Land, Water and Planning, as successor in law of the Secretary to the Department of Environment and Primary Industries, and Peter Barrington Kidd have entered into an agreement to terminate a Farm Forestry Incentive Scheme Land Owner Agreement in respect of the land set out in the Schedule.

SCHEDULE

Site Location	Title Details Volume/Folio	Dealing Number of Agreement terminated
Lot 1 on PS 120225 Parish of Lima	Volume 9195 Folio 219	AL615264T

NOTICE OF MAKING OF A LAND MANAGEMENT AGREEMENT

Notice is given under section 80 of the **Conservation, Forests and Lands Act 1987** that the Secretary to the Department of Environment, Land, Water and Planning, as successor in law of the Secretary to the Department of Environment and Primary Industries, and Douglas Henry Lade have entered into an agreement to terminate a Farm Forestry Incentive Scheme Land Owner Agreement in respect of the land set out in the Schedule.

SCHEDULE

Site Location	Title Details Volume/Folio	Dealing Number of Agreement terminated
Lot 1 and 2 on TP 845251X Parish of Ghin Ghin	Volume 8522 Folio 698	AL615265R

NOTICE OF MAKING OF A LAND MANAGEMENT AGREEMENT

Notice is given under section 80 of the **Conservation, Forests and Lands Act 1987** that the Secretary to the Department of Environment, Land, Water and Planning, as successor in law of the Secretary to the Department of Environment and Primary Industries, and Margaret Webb Lade and Douglas Henry Lade have entered into an agreement to terminate a Farm Forestry Incentive Scheme Land Owner Agreement in respect of the land set out in the Schedule.

SCHEDULE

Site Location	Title Details Volume/Folio	Dealing Number of Agreement terminated
Crown Allotments 64B and 64C Parish of Ghin Ghin	Volume 2889 Folio 687	AL615267M

NOTICE OF MAKING OF A LAND MANAGEMENT AGREEMENT

Notice is given under section 80 of the **Conservation, Forests and Lands Act 1987** that the Secretary to the Department of Environment, Land, Water and Planning, as successor in law of the Secretary to the Department of Environment and Primary Industries, and Neill Robert Lade have entered into an agreement to terminate a Farm Forestry Incentive Scheme Land Owner Agreement in respect of the land set out in the Schedule.

SCHEDULE

Site Location	Title Details Volume/Folio	Dealing Number of Agreement terminated
Land on PC 351016P Parish of Dropmore	Volume 10253 Folio 149	AL615268K

NOTICE OF MAKING OF A LAND MANAGEMENT AGREEMENT

Notice is given under section 80 of the **Conservation, Forests and Lands Act 1987** that the Secretary to the Department of Environment, Land, Water and Planning, as successor in law of the Secretary to the Department of Environment and Primary Industries, and Brian Wayne Lang have entered into an agreement to terminate a Farm Forestry Incentive Scheme Land Owner Agreement in respect of the land set out in the Schedule.

SCHEDULE

Site Location	Title Details Volume/Folio	Dealing Number of Agreement terminated
Lot 2 on PS 723796 Parish of Winton	Volume 11513 Folio 366	AL615271W

NOTICE OF MAKING OF A LAND MANAGEMENT AGREEMENT

Notice is given under section 80 of the **Conservation, Forests and Lands Act 1987** that the Secretary to the Department of Environment, Land, Water and Planning, as successor in law of the Secretary to the Department of Environment and Primary Industries, and Nicholas Patterson Linden and Kate Armstrong Stoney have entered into an agreement to terminate a Farm Forestry Incentive Scheme Land Owner Agreement in respect of the land set out in the Schedule.

SCHEDULE

Site Location	Title Details Volume/Folio	Dealing Number of Agreement terminated
Crown Allotment 8 Parish of Bontherambo	Volume 1581 Folio 193	AL615313H

NOTICE OF MAKING OF A LAND MANAGEMENT AGREEMENT

Notice is given under section 80 of the **Conservation, Forests and Lands Act 1987** that the Secretary to the Department of Environment, Land, Water and Planning, as successor in law of the Secretary to the Department of Environment and Primary Industries, and Lisa Catrina Martin have entered into an agreement to terminate a Farm Forestry Incentive Scheme Land Owner Agreement in respect of the land set out in the Schedule.

SCHEDULE

Site Location	Title Details Volume/Folio	Dealing Number of Agreement terminated
Crown Allotment 5 Parish of Wabonga South	Volume 9988 Folio 462	AL615315D AL615317Y

NOTICE OF MAKING OF A LAND MANAGEMENT AGREEMENT

Notice is given under section 80 of the **Conservation, Forests and Lands Act 1987** that the Secretary to the Department of Environment, Land, Water and Planning, as successor in law of the Secretary to the Department of Environment and Primary Industries, and Elizabeth Therese Mason, Nar Teaghlach Pty Ltd and Barholm Pty Ltd have entered into an agreement to terminate a Farm Forestry Incentive Scheme Land Owner Agreement in respect of the land set out in the Schedule.

SCHEDULE

Site Location	Title Details Volume/Folio	Dealing Number of Agreement terminated
Lot 1 on PS 146782Q Parish of Tallygaroopna	Volume 9575 Folio 180	AL615318W

NOTICE OF MAKING OF A LAND MANAGEMENT AGREEMENT

Notice is given under section 80 of the **Conservation, Forests and Lands Act 1987** that the Secretary to the Department of Environment, Land, Water and Planning, as successor in law of the Secretary to the Department of Environment and Primary Industries, and Graeme Charles Matthews have entered into an agreement to terminate a Farm Forestry Incentive Scheme Land Owner Agreement in respect of the land set out in the Schedule.

SCHEDULE

Site Location	Title Details Volume/Folio	Dealing Number of Agreement terminated
Lot 2 on PS 205606L Parish of Borodomanin	Volume 9726 Folio 009	AL615363R

NOTICE OF MAKING OF A LAND MANAGEMENT AGREEMENT

Notice is given under section 80 of the **Conservation, Forests and Lands Act 1987** that the Secretary to the Department of Environment, Land, Water and Planning, as successor in law of the Secretary to the Department of Environment and Primary Industries, and Winsome Mavis McPherson McCaughey have entered into an agreement to terminate a Farm Forestry Incentive Scheme Land Owner Agreement in respect of the land set out in the Schedule.

SCHEDULE

Site Location	Title Details Volume/Folio	Dealing Number of Agreement terminated
Lot 4 on PS 208855W Parish of Warrenbayne	Volume 9776 Folio 268	AL615365M

NOTICE OF MAKING OF A LAND MANAGEMENT AGREEMENT

Notice is given under section 80 of the **Conservation, Forests and Lands Act 1987** that the Secretary to the Department of Environment, Land, Water and Planning, as successor in law of the Secretary to the Department of Environment and Primary Industries, and Neil Patrick Nagle and Margaret Enid Nagle have entered into an agreement to terminate a Farm Forestry Incentive Scheme Land Owner Agreement in respect of the land set out in the Schedule.

SCHEDULE

Site Location	Title Details Volume/Folio	Dealing Number of Agreement terminated
Lot 11 on PS 110641, Parish of Ghin Ghin	Volume 9134 Folio 729	AL615368F

NOTICE OF MAKING OF A LAND MANAGEMENT AGREEMENT

Notice is given under section 80 of the **Conservation, Forests and Lands Act 1987** that the Secretary to the Department of Environment, Land, Water and Planning, as successor in law of the Secretary to the Department of Environment and Primary Industries, and Namberry Downs Pty Ltd have entered into an agreement to terminate a Farm Forestry Incentive Scheme Land Owner Agreement in respect of the land set out in the Schedule.

SCHEDULE

Site Location	Title Details Volume/Folio	Dealing Number of Agreement terminated
Crown Allotment 52D Section A Parish of Keelangie	Volume 6756 Folio 043	AL615429M

NOTICE OF MAKING OF A LAND MANAGEMENT AGREEMENT

Notice is given under section 80 of the **Conservation, Forests and Lands Act 1987** that the Secretary to the Department of Environment, Land, Water and Planning, as successor in law of the Secretary to the Department of Environment and Primary Industries, and Yvonne Betty Noble have entered into an agreement to terminate a Farm Forestry Incentive Scheme Land Owner Agreement in respect of the land set out in the Schedule.

SCHEDULE

Site Location	Title Details Volume/Folio	Dealing Number of Agreement terminated
Lot 1 on PS 710078C Parish of Moorngag Lot 2 on PS 710078C Parish of Moorngag	Volume 11486 Folio 340 Volume 11486 Folio 341	AL615487W

NOTICE OF MAKING OF A LAND MANAGEMENT AGREEMENT

Notice is given under section 80 of the **Conservation, Forests and Lands Act 1987** that the Secretary to the Department of Environment, Land, Water and Planning, as successor in law of the Secretary to the Department of Environment and Primary Industries, and Leslie James Oates have entered into an agreement to terminate a Farm Forestry Incentive Scheme Land Owner Agreement in respect of the land set out in the Schedule.

SCHEDULE

Site Location	Title Details Volume/Folio	Dealing Number of Agreement terminated
Crown Allotment 21A Parish of Merton	Volume 5953 Folio 429	AL615546H

NOTICE OF MAKING OF A LAND MANAGEMENT AGREEMENT

Notice is given under section 80 of the **Conservation, Forests and Lands Act 1987** that the Secretary to the Department of Environment, Land, Water and Planning, as successor in law of the Secretary to the Department of Environment and Primary Industries, and Miles Martin Oldmeadow and Judith Ann Oldmeadow have entered into an agreement to terminate a Farm Forestry Incentive Scheme Land Owner Agreement in respect of the land set out in the Schedule.

SCHEDULE

Site Location	Title Details Volume/Folio	Dealing Number of Agreement terminated
Lot 1 on PS 643566K Parish of Moorngag	Volume 11390 Folio 507	AL615647B

NOTICE OF MAKING OF A LAND MANAGEMENT AGREEMENT

Notice is given under section 80 of the **Conservation, Forests and Lands Act 1987** that the Secretary to the Department of Environment, Land, Water and Planning, as successor in law of the Secretary to the Department of Environment and Primary Industries, and Helen Mary Ogilbee have entered into an agreement to terminate a Farm Forestry Incentive Scheme Land Owner Agreement in respect of the land set out in the Schedule.

SCHEDULE

Site Location	Title Details Volume/Folio	Dealing Number of Agreement terminated
Lot 2 on PS 127660 Parish Warrenbayne	Volume 9381 Folio 069	AL615665Y

NOTICE OF MAKING OF A LAND MANAGEMENT AGREEMENT

Notice is given under section 80 of the **Conservation, Forests and Lands Act 1987** that the Secretary to the Department of Environment, Land, Water and Planning, as successor in law of the Secretary to the Department of Environment and Primary Industries, and Robert Gordon Oliver have entered into an agreement to terminate a Farm Forestry Incentive Scheme Land Owner Agreement in respect of the land set out in the Schedule.

SCHEDULE

Site Location	Title Details Volume/Folio	Dealing Number of Agreement terminated
Lot 4 on PS 324003N, Parish of Warrenbayne	Volume 10127 Folio 854	AL615667U

NOTICE OF MAKING OF A LAND MANAGEMENT AGREEMENT

Notice is given under section 80 of the **Conservation, Forests and Lands Act 1987** that the Secretary to the Department of Environment, Land, Water and Planning, as successor in law of the Secretary to the Department of Environment and Primary Industries, and Parkmont Pty Ltd have entered into an agreement to terminate a Farm Forestry Incentive Scheme Land Owner Agreement in respect of the land set out in the Schedule.

SCHEDULE

Site Location	Title Details Volume/Folio	Dealing Number of Agreement terminated
Lots 1, 2 and 3 on TP 410293H Parish of Broadford	Volume 4677 Folio 300	AL615670G

NOTICE OF MAKING OF A LAND MANAGEMENT AGREEMENT

Notice is given under section 80 of the **Conservation, Forests and Lands Act 1987** that the Secretary to the Department of Environment, Land, Water and Planning, as successor in law of the Secretary to the Department of Environment and Primary Industries, and Ronald Ormond Patterson have entered into an agreement to terminate a Farm Forestry Incentive Scheme Land Owner Agreement in respect of the land set out in the Schedule.

SCHEDULE

Site Location	Title Details Volume/Folio	Dealing Number of Agreement terminated
Crown Allotment 28 Section B Parish of Niagaroon	Volume 9108 Folio 449	AL615672C

NOTICE OF MAKING OF A LAND MANAGEMENT AGREEMENT

Notice is given under section 80 of the **Conservation, Forests and Lands Act 1987** that the Secretary to the Department of Environment, Land, Water and Planning, as successor in law of the Secretary to the Department of Environment and Primary Industries, and Neil Douglas Paulet and Janice Margaret Horsfield have entered into an agreement to terminate a Farm Forestry Incentive Scheme Land Owner Agreement in respect of the land set out in the Schedule.

SCHEDULE

Site Location	Title Details Volume/Folio	Dealing Number of Agreement terminated
Crown Allotment 47A Section A Parish of Keelangie	Volume 9945 Folio 809	AL615702V
Crown Allotment 47C Section A Parish of Keelangie	Volume 9945 Folio 810	

NOTICE OF MAKING OF A LAND MANAGEMENT AGREEMENT

Notice is given under section 80 of the **Conservation, Forests and Lands Act 1987** that the Secretary to the Department of Environment, Land, Water and Planning, as successor in law of the Secretary to the Department of Environment and Primary Industries, and Ronald Charles Peck and Linda May O'Bryan have entered into an agreement to terminate a Farm Forestry Incentive Scheme Land Owner Agreement in respect of the land set out in the Schedule.

SCHEDULE

Site Location	Title Details Volume/Folio	Dealing Number of Agreement terminated
Crown Allotment 12A, Parish of Flowerdale	Volume 9591 Folio 333	AL615740M

NOTICE OF MAKING OF A LAND MANAGEMENT AGREEMENT

Notice is given under section 80 of the **Conservation, Forests and Lands Act 1987** that the Secretary to the Department of Environment, Land, Water and Planning, as successor in law of the Secretary to the Department of Environment and Primary Industries, and Santenay Pty Ltd have entered into an agreement to terminate a Farm Forestry Incentive Scheme Land Owner Agreement in respect of the land set out in the Schedule.

SCHEDULE

Site Location	Title Details Volume/Folio	Dealing Number of Agreement terminated
Crown Allotment 10 Section D Parish of Tallangalook	Volume 10354 Folio 120	AL615776P

NOTICE OF MAKING OF A LAND MANAGEMENT AGREEMENT

Notice is given under section 80 of the **Conservation, Forests and Lands Act 1987** that the Secretary to the Department of Environment, Land, Water and Planning, as successor in law of the Secretary to the Department of Environment and Primary Industries, and Thomas Lachlan Simpson have entered into an agreement to terminate a Farm Forestry Incentive Scheme Land Owner Agreement in respect of the land set out in the Schedule.

SCHEDULE

Site Location	Title Details Volume/Folio	Dealing Number of Agreement terminated
Crown Allotment 108 Parish of Yea	Volume 10025 Folio 327	AL615828W

NOTICE OF MAKING OF A LAND MANAGEMENT AGREEMENT

Notice is given under section 80 of the **Conservation, Forests and Lands Act 1987** that the Secretary to the Department of Environment, Land, Water and Planning, as successor in law of the Secretary to the Department of Environment and Primary Industries, and John Arthur Steer have entered into an agreement to terminate a Farm Forestry Incentive Scheme Land Owner Agreement in respect of the land set out in the Schedule.

SCHEDULE

Site Location	Title Details Volume/Folio	Dealing Number of Agreement terminated
Crown Allotment 42D Parish of Acheron	Volume 8403 Folio 024	AL615864S

NOTICE OF MAKING OF A LAND MANAGEMENT AGREEMENT

Notice is given under section 80 of the **Conservation, Forests and Lands Act 1987** that the Secretary to the Department of Environment, Land, Water and Planning, as successor in law of the Secretary to the Department of Environment and Primary Industries, and Philip Mark Taft have entered into an agreement to terminate a Farm Forestry Incentive Scheme Land Owner Agreement in respect of the land set out in the Schedule.

SCHEDULE

Site Location	Title Details Volume/Folio	Dealing Number of Agreement terminated
Crown Allotment 21 Section B Parish of Switzerland	Volume 9449 Folio 012	AL615939M

NOTICE OF MAKING OF A LAND MANAGEMENT AGREEMENT

Notice is given under section 80 of the **Conservation, Forests and Lands Act 1987** that the Secretary to the Department of Environment, Land, Water and Planning, as successor in law of the Secretary to the Department of Environment and Primary Industries, and Tuck Services Pty Ltd have entered into an agreement to terminate a Farm Forestry Incentive Scheme Land Owner Agreement in respect of the land set out in the Schedule.

SCHEDULE

Site Location	Title Details Volume/ Folio	Dealing Number of Agreement terminated
Lot 2 on PS 147781M Parish of Alexandra Lot 3 on PS 147781M Parish of Alexandra Crown Allotment 8A and 9 Parish of Alexandra	Volume 9641 Folio 571 Volume 9641 Folio 572 Volume 10254 Folio 067	AL615941B

NOTICE OF MAKING OF A LAND MANAGEMENT AGREEMENT

Notice is given under section 80 of the **Conservation, Forests and Lands Act 1987** that the Secretary to the Department of Environment, Land, Water and Planning, as successor in law of the Secretary to the Department of Environment and Primary Industries, and Andrew Garry Walpole have entered into an agreement to terminate a Farm Forestry Incentive Scheme Land Owner Agreement in respect of the land set out in the Schedule.

SCHEDULE

Site Location	Title Details Volume/Folio	Dealing Number of Agreement terminated
Crown Allotment 153A Parish of Whorouly	Volume 6702 Folio 377	AL615967G AL615970T

NOTICE OF MAKING OF A LAND MANAGEMENT AGREEMENT

Notice is given under section 80 of the **Conservation, Forests and Lands Act 1987** that the Secretary to the Department of Environment, Land, Water and Planning, as successor in law of the Secretary to the Department of Environment and Primary Industries, and Mark Douglas Walpole have entered into an agreement to terminate a Farm Forestry Incentive Scheme Land Owner Agreement in respect of the land set out in the Schedule.

SCHEDULE

Site Location	Title Details Volume/Folio	Dealing Number of Agreement terminated
Crown Allotment 102A Parish of Whorouly Lot 1031 on PS 423609W Parish of Whorouly	Volume 3055 Folio 878 Volume 10784 Folio 672	AL616047W

NOTICE OF MAKING OF A LAND MANAGEMENT AGREEMENT

Notice is given under section 80 of the **Conservation, Forests and Lands Act 1987** that the Secretary to the Department of Environment, Land, Water and Planning, as successor in law of the Secretary to the Department of Environment and Primary Industries, and Alwyn Margaret Wherrett have entered into an agreement to terminate a Farm Forestry Incentive Scheme Land Owner Agreement in respect of the land set out in the Schedule.

SCHEDULE

Site Location	Title Details Volume/Folio	Dealing Number of Agreement terminated
Crown Allotment 84 Parish of Whanregarwen	Volume 2892 Folio 315	AL616059P

NOTICE OF MAKING OF A LAND MANAGEMENT AGREEMENT

Notice is given under section 80 of the **Conservation, Forests and Lands Act 1987** that the Secretary to the Department of Environment, Land, Water and Planning, as successor in law of the Secretary to the Department of Environment and Primary Industries, and Vanessa Claire Whitfield have entered into an agreement to terminate a Farm Forestry Incentive Scheme Land Owner Agreement in respect of the land set out in the Schedule.

SCHEDULE

Site Location	Title Details Volume/Folio	Dealing Number of Agreement terminated
Lot 1 on PS 336147U Parish of Dueran	Volume 10258 Folio 304	AL616062B

NOTICE OF MAKING OF A LAND MANAGEMENT AGREEMENT

Notice is given under section 80 of the **Conservation, Forests and Lands Act 1987** that the Secretary to the Department of Environment, Land, Water and Planning, as successor in law of the Secretary to the Department of Environment and Primary Industries, and Robin Charles Winfield Williams and Hilary Clare Williams have entered into an agreement to terminate a Farm Forestry Incentive Scheme Land Owner Agreement in respect of the land set out in the Schedule.

SCHEDULE

Site Location	Title Details Volume/Folio	Dealing Number of Agreement terminated
Lot 1 on TP 852786Q Parish of Yea Crown Allotment 31C Parish of Flowerdale	Volume 9449 Folio 773 Volume 7618 Folio 068	AL616063Y

NOTICE OF MAKING OF A LAND MANAGEMENT AGREEMENT

Notice is given under section 80 of the **Conservation, Forests and Lands Act 1987** that the Secretary to the Department of Environment, Land, Water and Planning, as successor in law of the Secretary to the Department of Environment and Primary Industries, and Trevor Johnston Wilson have entered into an agreement to terminate a Farm Forestry Incentive Scheme Land Owner Agreement in respect of the land set out in the Schedule.

SCHEDULE

Site Location	Title Details Volume/Folio	Dealing Number of Agreement terminated
Lot 1 on PS 127660 Parish of Warrenbayne	Volume 8679 Folio 657	AL616064W

NOTICE OF MAKING OF A LAND MANAGEMENT AGREEMENT

Notice is given under section 80 of the **Conservation, Forests and Lands Act 1987** that the Secretary to the Department of Environment, Land, Water and Planning, as successor in law of the Secretary to the Department of Environment and Primary Industries, and David John Gilbert have entered into an agreement to terminate a Farm Forestry Incentive Scheme Land Owner Agreement in respect of the land set out in the Schedule.

SCHEDULE

Site Location	Title Details Volume/Folio	Dealing Number of Agreement terminated
Crown Allotment 31, 32 and 33 Parish of Yielima	Volume 4679 Folio 749	AL783629L

NOTICE OF MAKING OF A LAND MANAGEMENT AGREEMENT

Notice is given under section 80 of the **Conservation, Forests and Lands Act 1987** that the Secretary to the Department of Environment, Land, Water and Planning, as successor in law of the Secretary to the Department of Environment and Primary Industries, and Melissa Anne McDowall and Gregory James Pritchard have entered into an agreement to terminate a Farm Forestry Incentive Scheme Land Owner Agreement in respect of the land set out in the Schedule.

SCHEDULE

Site Location	Title Details Volume/Folio	Dealing Number of Agreement terminated
Crown Allotment 38 Section C Parish of Dropmore	Volume 3078 Folio 441	AL783671M

NOTICE OF MAKING OF A LAND MANAGEMENT AGREEMENT

Notice is given under section 80 of the **Conservation, Forests and Lands Act 1987** that the Secretary to the Department of Environment, Land, Water and Planning, as successor in law of the Secretary to the Department of Environment and Primary Industries, and Lee Murray Murphy and Barbara Maria Murphy have entered into an agreement to terminate a Farm Forestry Incentive Scheme Land Owner Agreement in respect of the land set out in the Schedule.

SCHEDULE

Site Location	Title Details Volume/Folio	Dealing Number of Agreement terminated
Lot 2 on PS 643566K Parish of Moorngag	Volume 11390 Folio 508	AL615647B

NOTICE OF MAKING OF A LAND MANAGEMENT AGREEMENT

Notice is given under section 80 of the **Conservation, Forests and Lands Act 1987** that the Secretary to the Department of Environment, Land, Water and Planning, as successor in law of the Secretary to the Department of Environment and Primary Industries, and Christine Anne McGregor have entered into an agreement to terminate a Farm Forestry Incentive Scheme Land Owner Agreement in respect of the land set out in the Schedule.

SCHEDULE

Site Location	Title Details Volume/Folio	Dealing Number of Agreement terminated
Lot 2 on PS 327049V Parish of Kialla	Volume 10284 Folio 115	AL783698Q AL783699N

NOTICE OF MAKING OF A LAND MANAGEMENT AGREEMENT

Notice is given under section 80 of the **Conservation, Forests and Lands Act 1987** that the Secretary to the Department of Environment, Land, Water and Planning, as successor in law of the Secretary to the Department of Environment and Primary Industries, and Sheffield Trading Pty Ltd have entered into an agreement to terminate a Farm Forestry Incentive Scheme Land Owner Agreement in respect of the land set out in the Schedule.

SCHEDULE

Site Location	Title Details Volume/Folio	Dealing Number of Agreement terminated
Lot 1 on PS 327049V Parish of Kialla	Volume 10284 Folio 114	AL783707S AL783708Q

Copies of these agreements are available for public inspection between the hours of 9.00 and 4.00 pm at the offices of Department of Environment, Land, Water and Planning, 8 Nicholson Street, East Melbourne 3002, and Department of Environment, Land, Water and Planning, 89 Sydney Road, Benalla 3672.

ADAM FENNESSY
Secretary to the Department of Environment, Land, Water and Planning

Docklands Act 1991
URBAN RENEWAL AUTHORITY VICTORIA
Road Closure

Urban Renewal Authority Victoria, acting under section 28(1) of the **Docklands Act 1991**, having obtained the approval of the City of Melbourne as required under section 28(2), has resolved to close those parts of Docklands Drive, Docklands, that are shown hatched on the attached plan below.

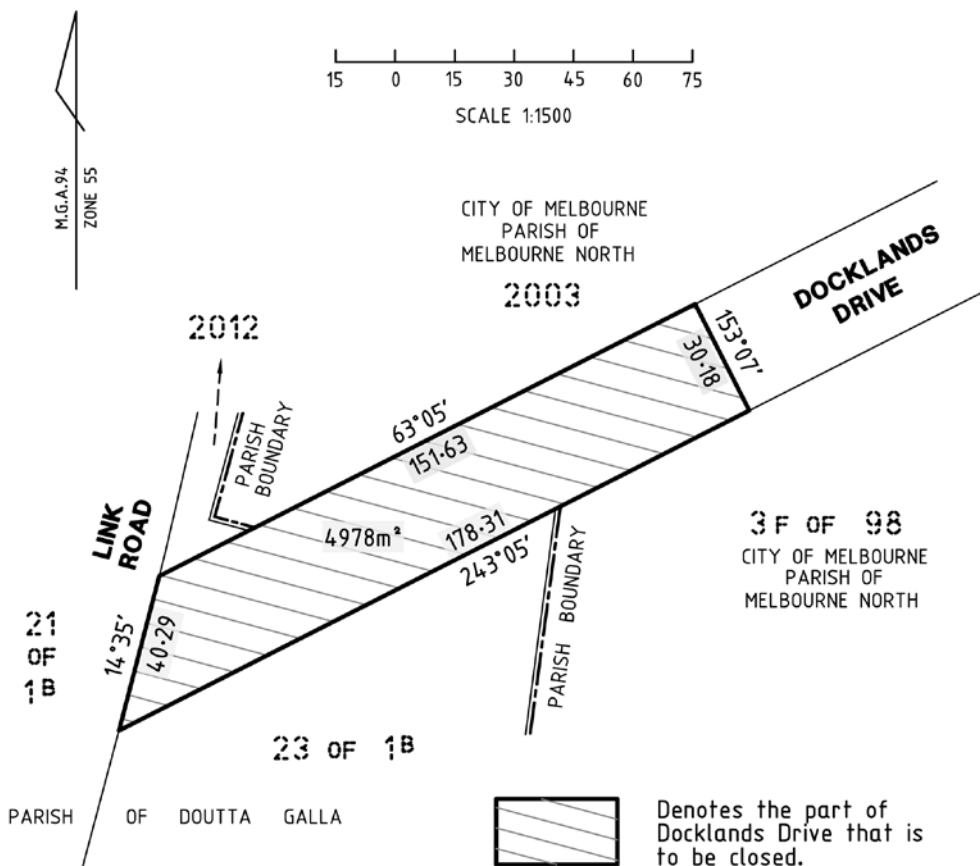

GREGORY ANDERSON
Chief Executive Officer

Education and Training Reform Act 2006

DECISION OF FORMAL HEARING PANEL QUASHED

Pursuant to section 2.6.46 of the **Education and Training Reform Act 2006** (the Act), the Victorian Institute of Teaching (the Institute) may find a teacher has engaged in serious misconduct/serious incompetence and/or is not fit to teach and may make a determination pursuant to subsection 2.6.46(2) to cancel the registration of the teacher.

On 14 July 2014, David Joseph Crook (Registration No. 338310) was found guilty of serious misconduct and not fit to teach.

On 14 July 2014, David Joseph Crook's registration as a teacher in Victoria was cancelled and he was disqualified from applying for registration for a period of five years.

On 20 May 2015, on appeal, the Supreme Court of Victoria quashed this determination and remitted the matter back to the Institute to be reheard.

On 25 May 2015, Mr Crook's registration as a teacher in Victoria was reinstated.

**Essential Services Commission Act 2001
Port Management Act 1995**

NOTICE OF DETERMINATION

Price Monitoring Determination for Victorian Ports 2015

The Essential Services Commission (the Commission) has issued its Price Monitoring Determination (the determination) for Victorian Ports 2015.

The determination provides for the regulation of the following prescribed services provided by the Port of Melbourne Corporation, the form of regulation being the monitoring of the price levels of those prescribed services:

- shipping channels in Port of Melbourne waters, including the shared channels used by ships bound either for the Port of Melbourne or the Port of Geelong;
- berths, buoys or dolphins for the berthing of vessels carrying container or motor vehicle cargoes in the Port of Melbourne; and
- short-term storage or cargo marshalling facilities for the loading or unloading of vessels carrying container or motor vehicle cargoes in the Port of Melbourne.

The determination takes effect from 1 July 2015.

The determination may have effect until 30 June 2020. However, the determination will cease to have effect before that date if legislation is passed establishing a new licensing and economic regulatory framework to apply to the private sector entity which is successful in the Port of Melbourne lease transaction, and which will be the provider of prescribed services at the port.

A copy of the determination is available from the Commission's website or by contacting the Commission at (03) 9032 1300.

Fisheries Act 1995**FURTHER QUOTA ORDER UNDER SECTION 64A – SEA URCHIN FISHERY**

I, Travis Dowling, Executive Director Regulation and Compliance (Fisheries), as delegate of the Minister for Agriculture, having undertaken consultation in accordance with section 3A of the **Fisheries Act 1995** (the Act), make the following Further Quota Order under section 64A of the Act for the Sea Urchin Fishery.

1. This Order applies for the period commencing on 1 July 2015 and ending on 30 June 2016, both dates inclusive (the quota period).
2. The total allowable catch for white sea urchin in the Port Phillip Bay Sea Urchin Zone for the quota period is 60 tonnes of unshucked urchin.
3. The total allowable catch for white sea urchin in the Eastern Sea Urchin Zone for the quota period is 57 tonnes of unshucked urchin.
4. The total allowable catch for black sea urchin in the Eastern Sea Urchin Zone for the quota period is 114 tonnes of unshucked urchin.
5. The quantity of white sea urchin comprising a quota unit in the Port Phillip Bay Sea Urchin Zone for the quota period is 100 kilograms.
6. The quantity of white sea urchin comprising a quota unit in the Eastern Sea Urchin Zone for the quota period is 100 kilograms.
7. The quantity of black sea urchin comprising a quota unit in Eastern Sea Urchin Zone for the quota period is 100 kilograms.

Notes:

1. There are 600 quota units for white sea urchin in the Port Phillip Bay Sea Urchin Zone.
2. There are 570 quota units for white sea urchin in the Eastern Sea Urchin Zone.
3. There are 1140 quota units for black sea urchin in the Eastern Sea Urchin Zone.

Dated 18 June 2015

TRAVIS DOWLING
Executive Director Regulation and Compliance (Fisheries)

Geographic Place Names Act 1998**NOTICE OF REGISTRATION OF GEOGRAPHIC NAMES**

The Registrar of Geographic Names hereby gives notice of the registration of the undermentioned place names.

Road Naming:

Change Request Number	Road Name	Locality	Naming Authority and Location
85262	Willombee View	Wattle Bank	Bass Coast Shire Council The road traverses north from Kongwak Inverloch Road.
85602	Gurrnoong Court	Box Hill South	Whitehorse City Council Formerly known as part Station Street. The road traverses south from Riversdale Road.
87145	Rakali Drive	Yarrowonga	Moira Shire Council Formerly known as part Lakeviews Circuit. The road traverses south from Lakeviews Circuit.
87271	Hopper Place	Wandana Heights	Greater Geelong City Council Formerly known as Kristy Place. The road traverses south from Madeline Drive.

Localities:

Change Request Number	Naming Authority	Affected Localities	Location
85861	Murrindindi Shire Council	Castella and Toolangi	To relocate the existing locality boundary between Castella and Toolangi from the north west corner of allotment 70B, PP3871, then southerly to the south west corner of Lot 1, LP123746, then directly south to a point on the northern boundary of Lot 1, TP414862, then generally westerly along the northern boundaries of Lot 1, TP414862 and Lot 1, TP671819, to the north west corner of Lot 1, TP127663, then generally south to the south west corner of Lot 1, TP127663, then generally westerly to the south west corner of Lot 1, TP819973, then generally southerly to the south east corner of Lot 1, TP125664, where it intersects the existing locality and municipal boundary. For further details see map at www.dtpli.vic.gov.au/namingplaces

Feature Naming:

Change Request Number	Place Name	Naming Authority and Location
86581	Eel Race Creek	Melbourne Water Formerly known as Eel Race Drain. Commences at the junction of Thompson Road and Dandenong–Frankston Road, in Carrum Downs and flows in a westerly direction through to Railway Parade, in Seaford. For further details see map at www.dtpli.vic.gov.au/namingplaces

Office of Geographic Names

Land Victoria
570 Bourke Street
Melbourne 3000JOHN E. TULLOCH
Registrar of Geographic Names

Marine Safety Act 2010
Section 208(2)

NOTICE OF ACTIVITY EXCLUSION ZONE

In accordance with section 208(2) of the **Marine Safety Act 2010**, Parks Victoria (the waterway manager for the Yarra River upstream of the port waters of the Port of Melbourne) gives notice that all persons and vessels not registered to take part in the Docklands Winter Fireworks Displays are prohibited from entering or remaining on the waters of the Yarra River (Victoria Harbour) in an area bounded by buoys in the locations detailed in Table 1.

The exclusion zone takes effect between 6.45 pm to 8.30 pm on Fridays 3, 10, 17, 24 and 31 July and 7, 14, 21 and 28 August 2015.

Table 1

Buoys	Location
1	144°56'23.24"E; 37°49'02.84"S
2	144°56'24.30"E; 37°49'07.21"S
3	144°56'22.53"E; 37°49'01.22"S
4	144°56'12.59"E; 37°49'02.95"S
5	144°56'19.00"E; 37°49'08.76"S

Dated 4 June 2015

THERESE CRANE
As delegate of Parks Victoria

Public Health and Wellbeing Act 2008
ORDER UNDER SECTION 33 OF THE
PUBLIC HEALTH AND WELLBEING ACT 2008

Surgical Consultative Council

I, Hon. Jill Hennessy MP, Minister for Health, acting under section 33 of the **Public Health and Wellbeing Act 2008** (the Act), by Order:

Appoint in accordance with sections 33(3), 33(4)(c) and 33(5) of the Act the following person to the Victorian Surgical Consultative Council (being the Council established by the Order of the Hon. Bronwyn Pike MP, Minister for Health, and dated 13 October 2004):

Name	Title	Term of Appointment
David Gordon Allen	Member	1 July 2015 to 30 June 2018

Remuneration of the person named and appointed above shall be in accordance with the Act and the Public Health and Wellbeing Regulations 2009 (Vic.) and the 'Appointment and Remuneration Guidelines for Victorian Government Boards, Statutory Bodies and Advisory Committees' issued by the Department of Premier and Cabinet.

HON. JILL HENNESSY MP
Minister for Health

Public Health and Wellbeing Act 2008
ORDER UNDER SECTION 33 OF THE
PUBLIC HEALTH AND WELLBEING ACT 2008

Surgical Consultative Council

I, Hon. Jill Hennessy MP, Minister for Health, acting under section 33 of the **Public Health and Wellbeing Act 2008** (the Act), by Order:

Appoint in accordance with sections 33(3), 33(4)(c) and 33(5) of the Act the following person to the Victorian Surgical Consultative Council (being the Council established by the Order of the Hon. Bronwyn Pike MP, Minister for Health, and dated 13 October 2004):

Name	Title	Term of Appointment
Yeliena Fay Baber	Member	1 July 2015 to 30 June 2018

Remuneration of the person named and appointed above shall be in accordance with the Act and the Public Health and Wellbeing Regulations 2009 (Vic.) and the 'Appointment and Remuneration Guidelines for Victorian Government Boards, Statutory Bodies and Advisory Committees' issued by the Department of Premier and Cabinet.

HON. JILL HENNESSY MP
Minister for Health

Public Health and Wellbeing Act 2008
ORDER UNDER SECTION 33 OF THE
PUBLIC HEALTH AND WELLBEING ACT 2008

Surgical Consultative Council

I, Hon. Jill Hennessy MP, Minister for Health, acting under section 33 of the **Public Health and Wellbeing Act 2008** (the Act), by Order:

Appoint in accordance with sections 33(3), 33(4)(c) and 33(5) of the Act the following person to the Victorian Surgical Consultative Council (being the Council established by the Order of the Hon. Bronwyn Pike MP, Minister for Health, and dated 13 October 2004):

Name	Title	Term of Appointment
Charles Barry Beiles	Member	1 July 2015 to 30 June 2018

Remuneration of the person named and appointed above shall be in accordance with the Act and the Public Health and Wellbeing Regulations 2009 (Vic.) and the 'Appointment and Remuneration Guidelines for Victorian Government Boards, Statutory Bodies and Advisory Committees' issued by the Department of Premier and Cabinet.

HON. JILL HENNESSY MP
Minister for Health

Public Health and Wellbeing Act 2008
ORDER UNDER SECTION 33 OF THE
PUBLIC HEALTH AND WELLBEING ACT 2008

Surgical Consultative Council

I, Hon. Jill Hennessy MP, Minister for Health, acting under section 33 of the **Public Health and Wellbeing Act 2008** (the Act), by Order:

Appoint in accordance with sections 33(3), 33(4)(c) and 33(5) of the Act the following person to the Victorian Surgical Consultative Council (being the Council established by the Order of the Hon. Bronwyn Pike MP, Minister for Health, and dated 13 October 2004):

Name	Title	Term of Appointment
Jo-Ann Bourke	Member	1 July 2015 to 30 June 2018

Remuneration of the person named and appointed above shall be in accordance with the Act and the Public Health and Wellbeing Regulations 2009 (Vic.) and the 'Appointment and Remuneration Guidelines for Victorian Government Boards, Statutory Bodies and Advisory Committees' issued by the Department of Premier and Cabinet.

HON. JILL HENNESSY MP
Minister for Health

Public Health and Wellbeing Act 2008
ORDER UNDER SECTION 33 OF THE
PUBLIC HEALTH AND WELLBEING ACT 2008

Surgical Consultative Council

I, Hon. Jill Hennessy MP, Minister for Health, acting under section 33 of the **Public Health and Wellbeing Act 2008** (the Act), by Order:

Appoint in accordance with sections 33(3), 33(4)(c) and 33(5) of the Act the following person to the Victorian Surgical Consultative Council (being the Council established by the Order of the Hon. Bronwyn Pike MP, Minister for Health, and dated 13 October 2004):

Name	Title	Term of Appointment
Grant Richard Brace	Member	1 July 2015 to 30 June 2018

Remuneration of the person named and appointed above shall be in accordance with the Act and the Public Health and Wellbeing Regulations 2009 (Vic.) and the 'Appointment and Remuneration Guidelines for Victorian Government Boards, Statutory Bodies and Advisory Committees' issued by the Department of Premier and Cabinet.

HON. JILL HENNESSY MP
Minister for Health

Public Health and Wellbeing Act 2008
ORDER UNDER SECTION 33 OF THE
PUBLIC HEALTH AND WELLBEING ACT 2008

Surgical Consultative Council

I, Hon. Jill Hennessy MP, Minister for Health, acting under section 33 of the **Public Health and Wellbeing Act 2008** (the Act), by Order:

Appoint in accordance with sections 33(3), 33(4)(c) and 33(5) of the Act the following person to the Victorian Surgical Consultative Council (being the Council established by the Order of the Hon. Bronwyn Pike MP, Minister for Health, and dated 13 October 2004):

Name	Title	Term of Appointment
Wendy Ann Brown	Member	1 July 2015 to 30 June 2018

Remuneration of the person named and appointed above shall be in accordance with the Act and the Public Health and Wellbeing Regulations 2009 (Vic.) and the 'Appointment and Remuneration Guidelines for Victorian Government Boards, Statutory Bodies and Advisory Committees' issued by the Department of Premier and Cabinet.

HON. JILL HENNESSY MP
Minister for Health

Public Health and Wellbeing Act 2008
ORDER UNDER SECTION 33 OF THE
PUBLIC HEALTH AND WELLBEING ACT 2008

Surgical Consultative Council

I, Hon. Jill Hennessy MP, Minister for Health, acting under section 33 of the **Public Health and Wellbeing Act 2008** (the Act), by Order:

Appoint in accordance with sections 33(3), 33(4)(c) and 33(5) of the Act the following person to the Victorian Surgical Consultative Council (being the Council established by the Order of the Hon. Bronwyn Pike MP, Minister for Health, and dated 13 October 2004):

Name	Title	Term of Appointment
Stephen Roland Clifforth	Member	1 July 2015 to 30 June 2018

Remuneration of the person named and appointed above shall be in accordance with the Act and the Public Health and Wellbeing Regulations 2009 (Vic.) and the 'Appointment and Remuneration Guidelines for Victorian Government Boards, Statutory Bodies and Advisory Committees' issued by the Department of Premier and Cabinet.

HON. JILL HENNESSY MP
Minister for Health

Public Health and Wellbeing Act 2008
ORDER UNDER SECTION 33 OF THE
PUBLIC HEALTH AND WELLBEING ACT 2008

Surgical Consultative Council

I, Hon. Jill Hennessy MP, Minister for Health, acting under section 33 of the **Public Health and Wellbeing Act 2008** (the Act), by Order:

Appoint in accordance with sections 33(3), 33(4)(c) and 33(5) of the Act the following person to the Victorian Surgical Consultative Council (being the Council established by the Order of the Hon. Bronwyn Pike MP, Minister for Health, and dated 13 October 2004):

Name	Title	Term of Appointment
Melissa Jayne Evans	Member	1 July 2015 to 30 June 2018

Remuneration of the person named and appointed above shall be in accordance with the Act and the Public Health and Wellbeing Regulations 2009 (Vic.) and the 'Appointment and Remuneration Guidelines for Victorian Government Boards, Statutory Bodies and Advisory Committees' issued by the Department of Premier and Cabinet.

HON. JILL HENNESSY MP
 Minister for Health

Public Health and Wellbeing Act 2008
ORDER UNDER SECTION 33 OF THE
PUBLIC HEALTH AND WELLBEING ACT 2008

Surgical Consultative Council

I, Hon. Jill Hennessy MP, Minister for Health, acting under section 33 of the **Public Health and Wellbeing Act 2008** (the Act), by Order:

Appoint in accordance with sections 33(3), 33(4)(c) and 33(5) of the Act the following person to the Victorian Surgical Consultative Council (being the Council established by the Order of the Hon. Bronwyn Pike MP, Minister for Health, and dated 13 October 2004):

Name	Title	Term of Appointment
Glenda Joy Gorrie	Member	1 July 2015 to 30 June 2018

Remuneration of the person named and appointed above shall be in accordance with the Act and the Public Health and Wellbeing Regulations 2009 (Vic.) and the 'Appointment and Remuneration Guidelines for Victorian Government Boards, Statutory Bodies and Advisory Committees' issued by the Department of Premier and Cabinet.

HON. JILL HENNESSY MP
 Minister for Health

Public Health and Wellbeing Act 2008
ORDER UNDER SECTION 33 OF THE
PUBLIC HEALTH AND WELLBEING ACT 2008

Surgical Consultative Council

I, Hon. Jill Hennessy MP, Minister for Health, acting under section 33 of the **Public Health and Wellbeing Act 2008** (the Act), by Order:

Appoint in accordance with sections 33(3), 33(4)(c) and 33(5) of the Act the following person to the Victorian Surgical Consultative Council (being the Council established by the Order of the Hon. Bronwyn Pike MP, Minister for Health, and dated 13 October 2004):

Name	Title	Term of Appointment
Liat Annette Harrower	Member	1 July 2015 to 30 June 2018

Remuneration of the person named and appointed above shall be in accordance with the Act and the Public Health and Wellbeing Regulations 2009 (Vic.) and the 'Appointment and Remuneration Guidelines for Victorian Government Boards, Statutory Bodies and Advisory Committees' issued by the Department of Premier and Cabinet.

HON. JILL HENNESSY MP
Minister for Health

Public Health and Wellbeing Act 2008
ORDER UNDER SECTION 33 OF THE
PUBLIC HEALTH AND WELLBEING ACT 2008

Surgical Consultative Council

I, Hon. Jill Hennessy MP, Minister for Health, acting under section 33 of the **Public Health and Wellbeing Act 2008** (the Act), by Order:

Appoint in accordance with sections 33(3), 33(4)(c) and 33(5) of the Act the following person to the Victorian Surgical Consultative Council (being the Council established by the Order of the Hon. Bronwyn Pike MP, Minister for Health, and dated 13 October 2004):

Name	Title	Term of Appointment
Rodney Thomas Judson	Member	1 July 2015 to 30 June 2018

Remuneration of the person named and appointed above shall be in accordance with the Act and the Public Health and Wellbeing Regulations 2009 (Vic.) and the 'Appointment and Remuneration Guidelines for Victorian Government Boards, Statutory Bodies and Advisory Committees' issued by the Department of Premier and Cabinet.

HON. JILL HENNESSY MP
Minister for Health

Public Health and Wellbeing Act 2008
ORDER UNDER SECTION 33 OF THE
PUBLIC HEALTH AND WELLBEING ACT 2008

Surgical Consultative Council

I, Hon. Jill Hennessy MP, Minister for Health, acting under section 33 of the **Public Health and Wellbeing Act 2008** (the Act), by Order:

Appoint in accordance with sections 33(3), 33(4)(c) and 33(5) of the Act the following person to the Victorian Surgical Consultative Council (being the Council established by the Order of the Hon. Bronwyn Pike MP, Minister for Health, and dated 13 October 2004):

Name	Title	Term of Appointment
Rebekah Kaberry	Member	1 July 2015 to 30 June 2018

Remuneration of the person named and appointed above shall be in accordance with the Act and the Public Health and Wellbeing Regulations 2009 (Vic.) and the 'Appointment and Remuneration Guidelines for Victorian Government Boards, Statutory Bodies and Advisory Committees' issued by the Department of Premier and Cabinet.

HON. JILL HENNESSY MP
Minister for Health

Public Health and Wellbeing Act 2008
ORDER UNDER SECTION 33 OF THE
PUBLIC HEALTH AND WELLBEING ACT 2008

Surgical Consultative Council

I, Hon. Jill Hennessy MP, Minister for Health, acting under section 33 of the **Public Health and Wellbeing Act 2008** (the Act), by Order:

Appoint in accordance with sections 33(3), 33(4)(c) and 33(5) of the Act the following person to the Victorian Surgical Consultative Council (being the Council established by the Order of the Hon. Bronwyn Pike MP, Minister for Health, and dated 13 October 2004):

Name	Title	Term of Appointment
Peter Henry Gerard Mortensen	Member	1 July 2015 to 30 June 2018

Remuneration of the person named and appointed above shall be in accordance with the Act and the Public Health and Wellbeing Regulations 2009 (Vic.) and the 'Appointment and Remuneration Guidelines for Victorian Government Boards, Statutory Bodies and Advisory Committees' issued by the Department of Premier and Cabinet.

HON. JILL HENNESSY MP
Minister for Health

Public Health and Wellbeing Act 2008
ORDER UNDER SECTION 33 OF THE
PUBLIC HEALTH AND WELLBEING ACT 2008

Surgical Consultative Council

I, Hon. Jill Hennessy MP, Minister for Health, acting under section 33 of the **Public Health and Wellbeing Act 2008** (the Act), by Order:

Appoint in accordance with sections 33(3), 33(4)(c) and 33(5) of the Act the following person to the Victorian Surgical Consultative Council (being the Council established by the Order of the Hon. Bronwyn Pike MP, Minister for Health, and dated 13 October 2004):

Name	Title	Term of Appointment
Louise Margaret O'Connor	Member	1 July 2015 to 30 June 2018

Remuneration of the person named and appointed above shall be in accordance with the Act and the Public Health and Wellbeing Regulations 2009 (Vic.) and the 'Appointment and Remuneration Guidelines for Victorian Government Boards, Statutory Bodies and Advisory Committees' issued by the Department of Premier and Cabinet.

HON. JILL HENNESSY MP
Minister for Health

Public Health and Wellbeing Act 2008
ORDER UNDER SECTION 33 OF THE
PUBLIC HEALTH AND WELLBEING ACT 2008

Surgical Consultative Council

I, Hon. Jill Hennessy MP, Minister for Health, acting under section 33 of the **Public Health and Wellbeing Act 2008** (the Act), by Order:

Appoint in accordance with sections 33(3), 33(4)(c) and 33(5) of the Act the following person to the Victorian Surgical Consultative Council (being the Council established by the Order of the Hon. Bronwyn Pike MP, Minister for Health, and dated 13 October 2004):

Name	Title	Term of Appointment
Marinis Pirpiris	Member	1 July 2015 to 30 June 2018

Remuneration of the person named and appointed above shall be in accordance with the Act and the Public Health and Wellbeing Regulations 2009 (Vic.) and the 'Appointment and Remuneration Guidelines for Victorian Government Boards, Statutory Bodies and Advisory Committees' issued by the Department of Premier and Cabinet.

HON. JILL HENNESSY MP
Minister for Health

Public Health and Wellbeing Act 2008
ORDER UNDER SECTION 33 OF THE
PUBLIC HEALTH AND WELLBEING ACT 2008

Surgical Consultative Council

I, Hon. Jill Hennessy MP, Minister for Health, acting under section 33 of the **Public Health and Wellbeing Act 2008** (the Act), by Order:

Appoint in accordance with sections 33(3), 33(4)(c) and 33(5) of the Act the following person to the Victorian Surgical Consultative Council (being the Council established by the Order of the Hon. Bronwyn Pike MP, Minister for Health, and dated 13 October 2004):

Name	Title	Term of Appointment
Graeme Alexander Thompson	Member	1 July 2015 to 30 June 2018

Remuneration of the person named and appointed above shall be in accordance with the Act and the Public Health and Wellbeing Regulations 2009 (Vic.) and the 'Appointment and Remuneration Guidelines for Victorian Government Boards, Statutory Bodies and Advisory Committees' issued by the Department of Premier and Cabinet.

HON. JILL HENNESSY MP
Minister for Health

Swinburne University of Technology Act 2010
Governance and Administration Statute 2012
Academic and Student Affairs Statute 2012
SWINBURNE UNIVERSITY OF TECHNOLOGY

Notice of Promulgation

In accordance with section 41(3) of the Swinburne University of Technology Governance and Administration Statute 2012 and Academic and Student Affairs Statute 2012, the following regulations made under the abovementioned statutes are hereby promulgated:

- Academic Senate (Amendment) Regulations 2014
- Honorary Degrees (Amendment) Regulations 2012

The regulations come into operation on the date of publication of this notice.

Copies of the regulations are available on the Swinburne University of Technology website.

TOM ROWAN
University Secretary
Swinburne University of Technology

**Water Act 1989****EXCISION OF LAND FROM SPECIFIED LOWER MURRAY URBAN AND RURAL WATER CORPORATION IRRIGATION DISTRICTS**

The Lower Murray Urban and Rural Water Corporation Board by resolution diminishes the extent of the Merbein Irrigation District, Red Cliffs Irrigation District and the First Mildura Irrigation District by removing the parcels of land as described below from each specified District.

MERBEIN IRRIGATION DISTRICT

Plan of Subdivision PS622882S

Lot A, Lots 1 to 3, Lots 21 to 23, Reserve R1, Reserve 1 and Reserve 2
Chaffey Street and Murrayview Court

Parish of Merbein

Total Area 4.764 ha

RED CLIFFS IRRIGATION DISTRICT

Plan of Subdivision PS503522Q

Lots 1 to 16, Lot A, Road Reserve R1 and Reserve No. 1
Indi Avenue, Immacolata Rise and Cufari Drive

Section B, Parish of Mildura

Total Area 6.219 ha

FIRST MILDURA IRRIGATION DISTRICT

Plan of Subdivision PS707630A

Lots 1 to 20 and Road Reserve R1

Sandilong Avenue and Kossman Court

Parish of Mildura

Total Area 1.077 ha

Plan of Subdivision PS633259B

Lots 61 to 64 and Lot 110

Plan of Subdivision PS648028N

Lots 13 to 60 and Reserve R1

Etiwanda Avenue and Ponderosa Way

Parish of Mildura

Total Area 4.519 ha

Plan of Subdivision PS725029H

Lot 1

Ontario Avenue

Parish of Mildura

Total Area 0.103 ha

Plan of Subdivision PS 707631X

Lots 1 to 12, 28, 29, Reserve No. 1 and Road Reserve R1

Eleventh Street and Cureton Avenue

Parish of Mildura

Total Area 12.662 ha

Plan of Subdivision PS 645231H

Lot 1

Fifteenth Street

Parish of Mildura

Total Area 0.300 ha

Plan of Subdivision PS 622880w

Lot 1 and Lot A

Fifteenth Street and Riverside Avenue

Parish of Mildura

Total Area 10.147 ha

Plan of Subdivision PS 625777X

Lots 1 and 2

Plan of Subdivision PS 607517D

Lots 1 to 8, Lots 10 and 11 and Lot A

Road Reserve R1

Sandilong Avenue

Parish of Mildura

Total Area 8.093 ha

Plan of Subdivision PS718055W

Lot 6 and Lot B

Bothroyd Court

Parish of Mildura

Total Area 2.475 ha

PHIL ENDLEY
Managing Director

Water Act 1989

PUBLIC NOTICE

Emergency Management Plan

North East Region Water Corporation (North East Water)

Notice under Section 159C of the **Water Act 1989**

North East Water has made an Emergency Management Plan under section 159A of the **Water Act 1989**, which has regard to the obligations contained in its respective Statement of Obligations, made by the Minister for Water under section 4I of the **Water Industry Act 1994**.

North East Water

Website: www.newater.com.au

Telephone: 1300 361 633

Postal address: PO Box 863, Wodonga, Victoria 3689

Office address: 83 Thomas Mitchell Drive, Wodonga, Victoria 3690

Workplace Injury Rehabilitation and Compensation Act 2013
NOTICE OF SCHEDULE OF FEES AND COSTS FOR REFERRALS OF
MEDICAL QUESTIONS TO THE MEDICAL PANELS

Pursuant to section 537(10) of the **Workplace Injury Rehabilitation and Compensation Act 2013**, I give notice of the following schedule of fees and costs (including GST) for referrals of medical questions to the Medical Panels. This notice takes effect on 1 July 2015 and is effective until 30 June 2016.

Item	Service	Fee or Cost (inc GST)
Presiding Member		
Standard or Complex Referral MPM001 MPM021* or MPM031* or MPM041* or MPM051*	For all work associated with any one referral of a complex nature, as determined by the Convenor, of a medical question or questions. * depending on the level of contribution and complexity required as determined by the Convenor	\$1298.00 \$1947.55 \$2379.85 \$2811.60 \$3244.45
Cancellation / Fail to Attend MPM018	Cancellation within 3 working days of examination or claimant non-attendance.	\$540.10
Panel Abandoned MPM012	Panel abandoned on day of examination.	75% of allocated fee
Additional Referral / Supplementary MPM013	Any work that arises from the submission of a supplementary question(s) for an existing referral which doesn't require an additional examination.	\$439.45
Member / Consultant		
Standard or Complex Referral MPM004* or MPM024* or MPM034*	For all work associated with any one referral of a standard or complex nature, as determined by the Convenor, of a medical question or questions. * depending on the level of contribution and complexity required as determined by the Convenor	\$896.50 \$1082.40 \$1515.25
Cancellation / Fail to Attend MPM019	Cancellation within 3 working days of examination or claimant non-attendance.	\$431.20
Panel Abandoned MPM015	Panel abandoned on day of examination.	75% of allocated fee
Additional Referral / Supplementary MPM014	Any work that arises from the submission of a supplementary question(s) for an existing referral which doesn't require an additional examination.	\$216.15
Member / Consultant – Speciality Psychiatry		
MPM020 – Neuro-Psychiatry MPM022 – Child Psychiatry	All work in association with a specialist Neuro-Psychiatry or Child Psychiatry examination.	\$1731.40 \$1731.40
General – Worksite Assessment		
MPM017	Worksite assessment, inclusive of all reasonable travelling expenses associated with attending a worksite within 50 km of the panellist's normal place of practice.	\$892.10

Item	Service	Fee or Cost (inc GST)
General – Other/Hourly Rate		
MPM025	Work performed at the request of the Convenor that is not otherwise remunerated under this schedule.	\$432.30 per hour
Investigations		
MPM016	Cost of medical investigations and/or reports requested by the Medical Panel.	At Cost
Interpreter		
MPM002	Interpreting costs for each examination or cancellation due to worker non-attendance.	At Cost
Registered Health Practitioner		
MPM003	Attendance before Medical Panel by Registered Health Practitioner.	At Cost

Dated 25 May 2015

THE HON. ROBIN SCOTT MLA
Minister for Finance

Wrongs Act 1958**NOTICE OF SCALE OF FEES AND COSTS FOR REFERRALS OF
MEDICAL QUESTIONS TO MEDICAL PANELS UNDER PART VBA**

Pursuant to section 28LXA(1) of the **Wrongs Act 1958**, I give notice of the following scale of fees and costs, fixed on the recommendation of the Convenor, for referrals of medical questions under Part VBA. This notice takes effect on 1 July 2015 and is effective until 30 June 2016.

Item	Service	Fee or Cost (inc GST)
Presiding Member		
Standard or Complex Referral MPW002 MPW021* or MPW031* or MPW041* or MPW051*	For all work associated with any one referral of a complex nature, as determined by the Convenor, of a medical question or questions. * depending on the level of contribution and complexity required as determined by the Convenor	\$1298.00 \$1947.55 \$2379.85 \$2811.60 \$3244.45
Cancellation / Fail to Attend MPW018	Cancellation within 3 working days of examination or claimant non-attendance.	\$540.10
Panel Abandoned MPW012	Panel abandoned on day of examination.	75% of allocated fee
Member / Consultant		
Standard or Complex Referral MPW004* or MPW024* or MPW034*	For all work associated with any one referral of a standard or complex nature, as determined by the Convenor, of a medical question or questions. * depending on the level of contribution and complexity required as determined by the Convenor	\$896.50 \$1082.40 \$1515.25
Cancellation / Fail to Attend MPW006	Cancellation within 3 working days of examination or claimant non-attendance.	\$431.20
Panel Abandoned MPW015	Panel abandoned on day of examination.	75% of allocated fee
Member / Consultant – Speciality Psychiatry		
MPW009 – Neuro-Psychiatry MPW022 – Child Psychiatry	All work in association with a specialist Neuro-Psychiatry or Child Psychiatry examination.	\$1731.40 \$1731.40
Administration Fee		
MPW001	Administration cost in association with any reference to Medical Panels.	\$1699.32
Administration Fee – Reference withdrawn		
MPW003	Administration cost in association with any reference to Medical Panels which is withdrawn up to 3 working days before the Panel occurs.	\$1019.59
General – Other/Hourly Rate		
MPW025	Work performed at the request of the Convenor that is not otherwise remunerated under this schedule.	\$432.30 per hour

Item	Service	Fee or Cost (inc GST)
Investigations		
MPW010	Cost of medical investigations and/or reports requested by the Medical Panel.	At Cost
Interpreter		
MPW007	Interpreting costs for each examination or cancellation due to worker non-attendance.	At Cost
Registered Health Practitioner		
MPW008	Attendance before Medical Panel by Registered Health Practitioner.	At Cost

Dated 14 June 2015

THE HON. MARTIN PAKULA MP
Attorney-General

Planning and Environment Act 1987**BALLARAT PLANNING SCHEME**

Notice of Approval of Amendment

Amendment C188

The Minister for Planning has approved Amendment C188 to the Ballarat Planning Scheme.

The Amendment comes into operation on the date this notice is published in the Government Gazette.

The Amendment introduces permanent heritage controls to land at 436 Wendouree Parade, Ballarat.

A copy of the Amendment can be inspected, free of charge, at the Department of Environment, Land, Water and Planning website at www.delwp.vic.gov.au/public-inspection and free of charge, during office hours, at the offices of the Ballarat City Council, Ballarat Town Hall, Sturt Street, Ballarat.

JIM GARDNER
Executive Director
Statutory Planning and Heritage
Department of Environment, Land, Water and Planning

Planning and Environment Act 1987**CASEY PLANNING SCHEME**

Notice of Approval of Amendment

Amendment C115

The Minister for Planning has approved Amendment C115 to the Casey Planning Scheme.

The Amendment comes into operation on the date this notice is published in the Government Gazette.

The Amendment amends the Schedules to Clause 52.03 and 81.01 to include the Incorporated Document 'Advertising Signs, 950 Ballarto Road, Botanic Ridge May 2014' to allow for the consideration of Category 3 Advertising Signs under Clause 52.05.

The Minister has granted the following permit under Division Five Part Four of the Act:

Permit No.	Description of land
Pln A00857/07 (formally P638/07)	Use and Development for Refuse Disposal (Solid Inert Waste Landfill) and the Display of Business Identification Signs

A copy of the Amendment can be inspected, free of charge, at the Department of Environment, Land, Water and Planning website at www.delwp.vic.gov.au/public-inspection and free of charge, during office hours, at the offices of the City of Casey, Civic Centre, Magid Drive, Narre Warren.

JIM GARDNER
Executive Director
Statutory Planning and Heritage
Department of Environment, Land, Water and Planning

Planning and Environment Act 1987

CASEY PLANNING SCHEME

Notice of Approval of Amendment

Amendment C203

The Minister for Planning has approved Amendment C203 to the Casey Planning Scheme.

The Amendment comes into operation on the date this notice is published in the Government Gazette.

The Amendment rezones land at 110 Dandenong–Hastings Road (Lot 1 PS438590H), Lynbrook, from General Residential Zone to Commercial 2 Zone.

A copy of the Amendment can be inspected, free of charge, at the Department of Environment, Land, Water and Planning website at www.delwp.vic.gov.au/public-inspection and free of charge, during office hours, at the offices of the Casey City Council, Civic Centre, Magid Drive, Narre Warren, Victoria 3805.

JIM GARDNER
Executive Director
Statutory Planning and Heritage
Department of Environment, Land, Water and Planning

Planning and Environment Act 1987

CASEY PLANNING SCHEME

Notice of Approval of Amendment

Amendment C214

The Minister for Planning has approved Amendment C214 to the Casey Planning Scheme.

The Amendment comes into operation on the date this notice is published in the Government Gazette.

The Amendment alters the planning scheme maps and the Schedule to the Heritage Overlay so that the Casey Planning Scheme is consistent with the Victorian Heritage Register.

A copy of the Amendment can be inspected, free of charge, at the Department of Environment, Land, Water and Planning website at www.delwp.vic.gov.au/public-inspection and free of charge, during office hours, at the City of Casey, Magid Drive, Narre Warren.

JIM GARDNER
Executive Director
Statutory Planning and Heritage
Department of Environment, Land, Water and Planning

Planning and Environment Act 1987
GREATER BENDIGO PLANNING SCHEME
Notice of Approval of Amendment
Amendment C130

The Minister for Planning has approved Amendment C130 to the Greater Bendigo Planning Scheme.

The Amendment comes into operation on the date this notice is published in the Government Gazette.

The Amendment rezones land known as 13 (part) and 17 Chauncey Street and 30 Playne Street, Heathcote from General Residential Zone to Commercial 1 Zone and deletes Schedule 1 to the Neighbourhood Character Overlay (Clause 45.03) from the same land.

The Minister has granted the following permit under Division Five Part Four of the Act:

Permit No.	Description of land
DC/635/2011	13 and 17 Chauncey Street, 30 Playne Street and 175–177 High Street, Heathcote.

A copy of the Amendment can be inspected, free of charge, at the Department of Environment, Land, Water and Planning website at www.delwp.vic.gov.au/public-inspection and free of charge, during office hours, at the offices of the City of Greater Bendigo, Planning Department, Hopetoun Mill, 15 Hopetoun Street, Bendigo, and City of Greater Bendigo, Heathcote Office, 125 High Street, Heathcote.

JIM GARD'NER
Executive Director
Statutory Planning and Heritage
Department of Environment, Land, Water and Planning

Planning and Environment Act 1987
GREATER GEELONG PLANNING SCHEME
Notice of Approval of Amendment
Amendment C312

The Minister for Planning has approved Amendment C312 to the Greater Geelong Planning Scheme.

The Amendment comes into operation on the date this notice is published in the Government Gazette.

The Amendment revises Clause 21.14 The Bellarine Peninsula to include the land use directions and policies contained in the 'St Leonards Structure Plan March 2015'.

A copy of the Amendment can be inspected, free of charge, at the Department of Environment, Land, Water and Planning website at www.delwp.vic.gov.au/public-inspection and free of charge, during office hours, at the offices of the Greater Geelong City Council, 100 Brougham Street, Geelong.

JIM GARD'NER
Executive Director
Statutory Planning and Heritage
Department of Environment, Land, Water and Planning

Planning and Environment Act 1987
MELBOURNE PLANNING SCHEME
Notice of Approval of Amendment
Amendment C263

The Minister for Planning has approved Amendment C263 to the Melbourne Planning Scheme. The Amendment comes into operation on the date this notice is published in the Government Gazette.

The Amendment extends the expiry date of Clause 43.02 Schedule 62 until 27 September 2015.

A copy of the Amendment can be inspected, free of charge, at the Department of Environment, Land, Water and Planning website at www.delwp.vic.gov.au/public-inspection and free of charge, during office hours, at the offices of the Melbourne City Council, Level 3, 240 Little Collins Street, Melbourne.

JIM GARDNER
Executive Director
Statutory Planning and Heritage
Department of Environment, Land, Water and Planning

Planning and Environment Act 1987
MORNINGTON PENINSULA PLANNING SCHEME
Notice of Approval of Amendment
Amendment C188 (Part 1)

The Minister for Planning has approved Amendment C188 (Part 1) to the Mornington Peninsula Planning Scheme.

The Amendment comes into operation on the date this notice is published in the Government Gazette.

The Amendment corrects mapping anomalies in the Mornington Peninsula Planning Scheme and amends Clause 21.12 and Schedule 14 to the Design and Development Overlay to introduce the 'Flinders Village Centre Statement of Significance (2009)' as a reference document.

A copy of the Amendment can be inspected, free of charge, at the Department of Environment, Land, Water and Planning website at www.delwp.vic.gov.au/public-inspection and free of charge, during office hours, at the offices of Mornington Peninsula Shire Council, 90 Besgrove Street, Rosebud; 2 Queen Street, Mornington; and 21 Marine Parade, Hastings.

JIM GARDNER
Executive Director
Statutory Planning and Heritage
Department of Environment, Land, Water and Planning

Planning and Environment Act 1987
YARRA RANGES PLANNING SCHEME
Notice of Approval of Amendment
Amendment C129

The Minister for Planning has approved Amendment C129 to the Yarra Ranges Planning Scheme.

The Amendment comes into operation on the date this notice is published in the Government Gazette.

The Amendment inserts a new incorporated document titled ‘261 Mount Dandenong Tourist Road, Ferny Creek: Development and Use of Land for a Restaurant and a Caretaker’s House, November 2013’ in the Schedule to Clause 52.03 and the Schedule to Clause 81.01 to allow land identified in the incorporated document to be used and developed for the purpose of a restaurant and caretaker’s house subject to conditions.

A copy of the Amendment can be inspected, free of charge, at the Department of Environment, Land, Water and Planning website at www.delwp.vic.gov.au/public-inspection and free of charge, during office hours, at the offices of the Yarra Ranges Shire Council, Civic Centre, Anderson Street, Lilydale.

JIM GARD’NER
Executive Director
Statutory Planning and Heritage
Department of Environment, Land, Water and Planning

Planning and Environment Act 1987
GREATER GEELONG PLANNING SCHEME
Notice of Lapsing of Amendment
Amendment C276

The Greater Geelong City Council has resolved to abandon Amendment C276 the Greater Geelong Planning Scheme.

The Amendment proposed to rezone land at 35 Hams Road and 151–229 Anglesea Road, Waurm Ponds, from Farming Zone to General Residential Zone (Schedule 1) and apply the Development Plan Overlay to the land. The Amendment also proposed to make a number of consequential zoning and overlay changes to land within the VicRoads’ road reserve (Geelong Ring Road Sections 4B and 4C), land at 25 Hams Road, Waurm Ponds, and Barwon Water land adjacent to the southern boundary of the land by rezoning land to the Road Zone Category 1 and Public Use Zone 1 (as required) and deleting the Public Acquisition Overlay 3 from the land.

The Amendment lapsed on 28 April 2015.

JIM GARD’NER
Executive Director
Statutory Planning and Heritage
Department of Environment, Land, Water and Planning

ORDERS IN COUNCIL

Crown Land (Reserves) Act 1978
NOTICE OF INTENTION TO REVOKE
TEMPORARY RESERVATIONS

Order in Council

The Governor in Council under section 10 of the **Crown Land (Reserves) Act 1978** gives notice of intention to revoke the following temporary reservations:

DUNOLLY – The temporary reservation by Order in Council of 18 December, 1979 of an area of 1394 square metres of land being Crown Allotment 16A, Section 29, Township of Dunolly, Parish of Dunolly as a site for Public Buildings. (Rs 11005)

DUNOLLY – The temporary reservation by Order in Council of 14 November, 1950 of an area of 4174 square metres, more or less, of land in the Township of Dunolly, Parish of Dunolly as a site for Police purposes (now described as Crown Allotment 16B, Section 29), revoked as to part by Order in Council of 27 November, 1979 **so far only** as the portion containing 1556 square metres being Crown Allotment 2030, Township of Dunolly, Parish of Dunolly as indicated by hatching on plan GP3421 hereunder. – (GP3421) – (Rs 6592)

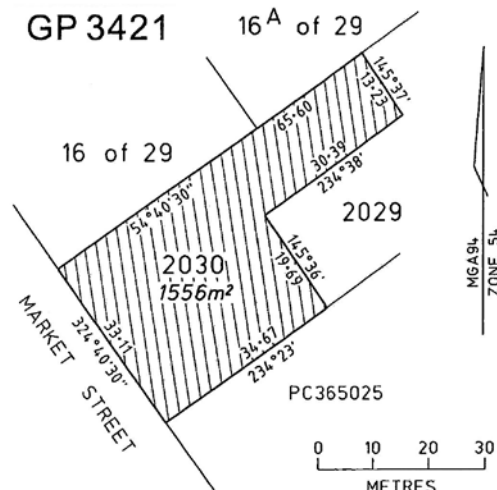

BUMBANG – The temporary reservation by Order in Council of 6 December, 1949 of an area of 242.81 hectares, more or less, of land in the Township and Parish of Bumbang as a site for Public Purposes, revoked as to part by various Orders in Council, **so far only** as the

portion containing 2643 square metres, more or less, being Crown Allotment 2049, Parish of Bumbang as indicated by hatching on plan GP3267 hereunder. – (GP3267) – (Rs 5615)

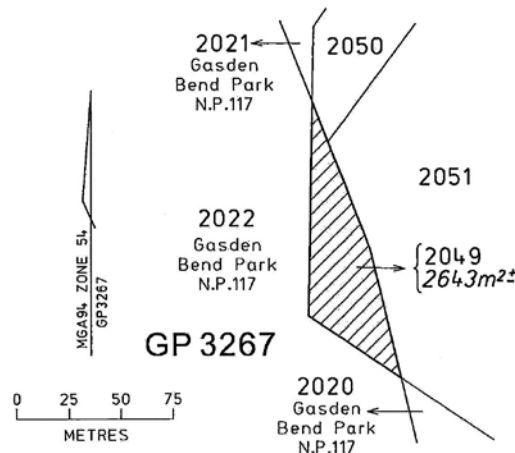

WALPEUP – The temporary reservation by Order in Council of 30 September, 1940 of an area of 6.875 hectares of land in the Parish of Walpeup (now described as Crown Allotment 16N) as a site for Water supply purposes, **so far only** as Crown Allotment 2008, Parish of Walpeup [area 9361 square metres, more or less] and Crown Allotment 2009, Parish of Walpeup [area 2.1 hectares, more or less], as shown on plan LEGL./14-609 lodged in the Central Plan Office of the Department of Environment, Land, Water and Planning. – (Rs 5095)

WALPEUP – The temporary reservation by Order in Council of 12 September, 1989 of an area of 4.189 hectares of land in the Parish of Walpeup (being Crown Allotment 16J) as a site for Water supply, **so far only** as Crown Allotment 2005, Parish of Walpeup [area 2.0 hectares, more or less], as shown on plan LEGL./14-609 lodged in the Central Plan Office of the Department of Environment, Land, Water and Planning. – (Rs 5095)

BENAMBRA – The temporary reservation by Order in Council of 10 September, 1909 of an area of 2226 square metres of land in the Township of Benambra, Parish of Hinnomunjie (now described as Crown Allotment 3, Section 7A) as a site for State School purposes, revoked as to part by Order in Council of 27 September, 1994 so far as the balance remaining. – (Rs 5832)

BENAMBRA – The temporary reservation by Order in Council of 10 September, 1907 of an area of 9713 square metres of land in the Township of Benambra, Parish of Hinno-Munjie (now described as Crown Allotment 4, Section 7A) as a site for a State School. – (Rs 5835)

BENAMBRA – The temporary reservation by Order in Council of 25 July, 1950 of an area of 3238 square metres, more or less, of land in the Township of Benambra, Parish of Hinno-Munjie (now described as Crown Allotment 5, Section 7A) as a site for a State School, in addition to and adjoining the land reserved thereto by Order in Council of 10 September, 1907. – (Rs 5835)

BENAMBRA – The temporary reservation by Order in Council of 28 April, 1953 of an area of 7892 square metres of land in the Township of Benambra, Parish of Hinno-Munjie (now described as Crown Allotment 6, Section 7A) as a site for State School purposes, in addition to and adjoining the land reserved thereto by Order in Council of 10 September, 1907. – (Rs 5835)

HINNO-MUNJIE – The temporary reservation by Order in Council of 2 July, 1919 of an area of 2.021 hectares of land in the Parish of Hinno-Munjie (now described as Crown Allotment 2B, Section J) as a site for a State School, revoked as to part by Order in Council of 27 September, 1994 so far as the balance remaining. – (Rs 1937)

This Legislative Instrument is effective from the date on which it is published in the Government Gazette.

Dated 23 June 2015

Responsible Minister
HON LISA NEVILLE MP
Minister for Environment, Climate Change
and Water

YVETTE CARISBROOKE
Clerk of the Executive Council

Crown Land (Reserves) Act 1978

TEMPORARY RESERVATION OF CROWN LANDS

Order in Council

The Governor in Council under section 4(1) of the **Crown Land (Reserves) Act 1978** temporarily reserves the following Crown lands which in his opinion are required for the purposes mentioned:-

MUNICIPAL DISTRICT OF THE BALLARAT CITY COUNCIL

BALLARAT EAST – Public purposes; area 210 square metres, being Crown Allotment 23A, Section 56, Township of Ballarat East, Parish of Ballarat as shown on Original Plan No. OP123678 lodged in the Central Plan Office of the Department of Environment, Land, Water and Planning. – (05P101306)

MUNICIPAL DISTRICT OF THE MOUNT ALEXANDER SHIRE COUNCIL

CASTLEMAINE – Conservation of an area of historic interest; area 764 square metres, being Crown Allotment 3C, Section 20, Township of Castlemaine, Parish of Castlemaine as indicated by hatching on plan GP3452 hereunder. – (GP3452) – (06P134730)

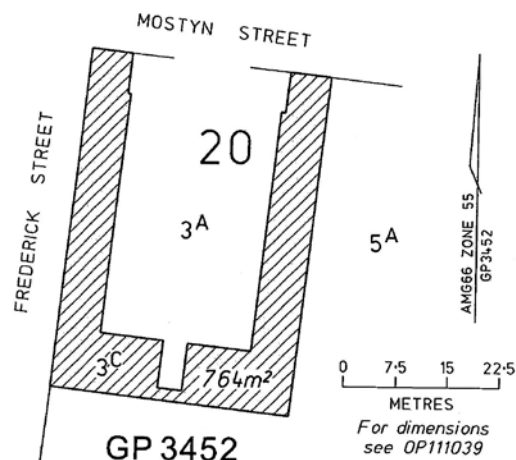

MUNICIPAL DISTRICT OF THE EAST GIPPSLAND SHIRE COUNCIL

LUCKNOW – Public park, recreation and public purposes, area 2740 square metres, being Crown Allotment 2009, Township of Lucknow, Parish of Wy-Yung as shown on Original Plan No. OP123602 lodged in the Central Plan Office of the Department of Environment, Land, Water and Planning. – (1601496)

MUNICIPAL DISTRICT OF THE CASEY CITY COUNCIL

SHERWOOD – Public purposes; area 1213 square metres, being Crown Allotment 2028, Parish of Sherwood as shown on Original Plan No. OP123693 lodged in the Central Plan Office of the Department of Environment, Land, Water and Planning. – (1201931)

MUNICIPAL DISTRICT OF THE
HOBSONS BAY CITY COUNCIL

TRUGANINA – Public purposes (Environmental purposes); area 1.457 hectares, being Crown Allotment 3B, Section A, Parish of Truganina as indicated by hatching on plan GP3418 hereunder. – (GP3418) – (2020316)

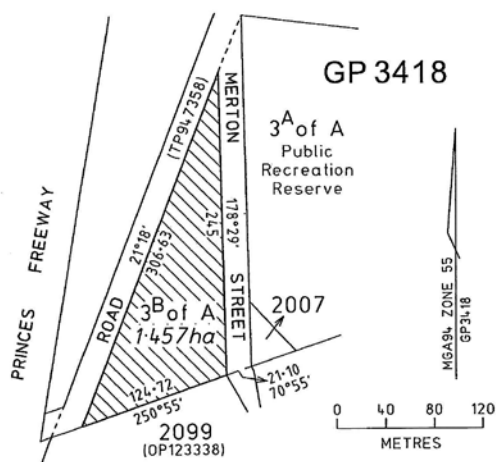

MUNICIPAL DISTRICT OF THE
MILDURA RURAL CITY COUNCIL

KOONDA – Preservation of species of native plants; being Crown Allotment 1, Parish of Koonda (area 314.1 hectares) and Crown Allotment 2, Parish of Koonda (area 194.8 hectares) as shown on Original Plan No. OP123527 lodged in the Central Plan Office of the Department of Environment, Land, Water and Planning. – (012020835)

TORRITA – Preservation of species of native plants and animals; area 48.8 hectares, more or less, being Crown Allotment 2002, Township of Torrita, Parish of Nyang as shown hatched on Plan No. LEGL./14-075 lodged in the Central Plan Office of the Department of Environment, Land, Water and Planning. – (2020709)

PAIGNIE and WYMLET – Conservation of an area of natural interest; being Crown Allotment 53A, Parish of Paignie [area 195.4 hectares] as shown on Original Plan No. 123521; Crown Allotment 32C, Parish of Paignie [area 50.10 hectares] as shown on Original Plan No. 123522 and Crown Allotment 55A, Parish of Wymlet [area 192.8 hectares] as shown on Original Plan No. OP123519; all plans lodged in the Central Plan Office of the Department of Environment, Land, Water and Planning. – (012020699)

WALPEUP – Conservation of native plants and animals; being Crown Allotments 2A, 3A, 2007 and 2008, Township of Walpeup, Parish of Walpeup [total area 18.2 hectares, more or less], as shown hatched on Plan No. LEGL./14-091 and Crown Allotments 16M, 2005, 2008 and 2009, Parish of Walpeup [total area 6.54 hectares, more or less], as shown hatched on Plan No. LEGL./14-609 both plans lodged in the Central Plan Office of the Department of Environment, Land, Water and Planning. – (012020834)

This Legislative Instrument is effective from the date on which it is published in the Government Gazette.

Dated 23 June 2015

Responsible Minister
HON LISA NEVILLE MP
Minister for Environment, Climate Change
and Water

YVETTE CARISBROOKE
Clerk of the Executive Council

Land Act 1958

CLOSURE OF UNUSED ROADS

Order in Council

The Governor in Council under section 349 of the **Land Act 1958** and with the concurrence in writing of the municipality in which the roads are situated closes the following unused roads:

MUNICIPAL DISTRICT OF THE
MILDURA RURAL CITY COUNCIL

WALPEUP – The roads in the Township of Walpeup, Parish of Walpeup being Crown Allotments 2002, 2003, 2004, 2005 and 2006 as shown hatched on Plan No. LEGL./14-090 lodged in the Central Plan Office of the Department of Environment, Land, Water and Planning. – (012020834)

This Legislative Instrument is effective from the date on which it is published in the Government Gazette.

Dated 23 June 2015

Responsible Minister
HON LISA NEVILLE MP
Minister for Environment, Climate Change
and Water

YVETTE CARISBROOKE
Clerk of the Executive Council

Land Act 1958
CLOSURE OF UNUSED ROAD
 Order in Council

The Governor in Council under section 349 of the **Land Act 1958** and with the concurrence in writing of the municipality in which the road is situated and the owners of land adjoining the road closes the following unused road:

MUNICIPAL DISTRICT OF THE SOUTH GIPPSLAND SHIRE COUNCIL

KORUMBURRA – The road in the Township of Korumburra, Parish of Korumburra being Crown Allotment 2017 as indicated by hatching on plan GP3474 hereunder. – (GP3474) – (15L10-5745)

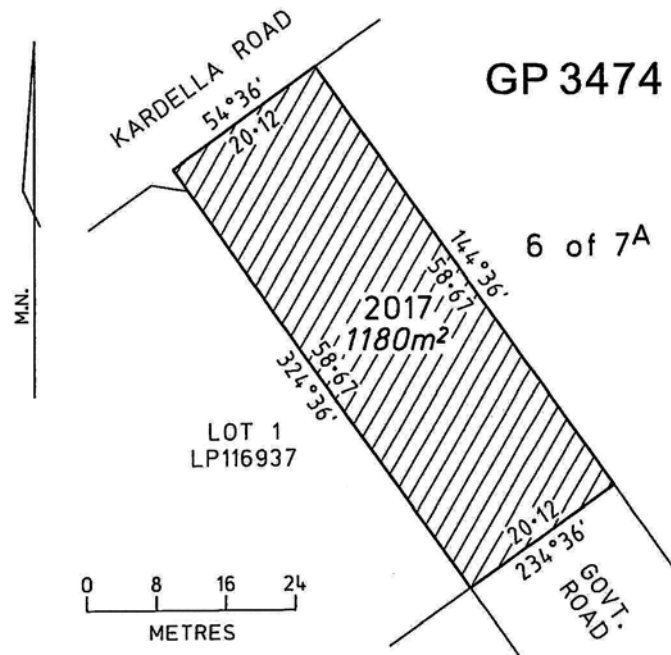

This Legislative Instrument is effective from the date on which it is published in the Government Gazette.

Dated 23 June 2015

Responsible Minister
 HON LISA NEVILLE MP
 Minister for Environment, Climate Change and Water

YVETTE CARISBROOKE
 Clerk of the Executive Council

Honorary Justices Act 2014
APPOINTMENT OF JUSTICES OF THE PEACE
Order in Council

The Governor in Council under section 7 of the **Honorary Justices Act 2014**, appoints the following persons as Justices of the Peace in the State of Victoria.

Surname/Given Names

AGARWAL, Ravi

CARR, Allison

COOPER-WARES, Leslie

CARR, Allison

DAVIES, Nigel

GOONAN, Timothy

HALL, Anne-Louise

HAWK, Caleb

HORWOOD, Marcus

LANYON, Ian

LEUNG, Matthew

MATTHEWS, Andrea

MCLEAN, Tamsin

NEWTON, Kenneth

NGUYEN, Thuc

O'HARE, Michael

PROVAN, David

SCHWEGLER, Heidi

SLOCOMBE, Ryan

VISSENGA, Claire

WIDMER, Geoffrey

Dated 23 June 2015

Responsible Minister:

THE HON MARTIN PAKULA MP

Attorney-General

YVETTE CARISBROOKE
Clerk of the Executive Council

Transport (Compliance and Miscellaneous) Act 1983

DECLARATION OF RAIL FREIGHT OPERATORS

Order in Council

The Governor in Council, under section 2(2B) of the **Transport (Compliance and Miscellaneous) Act 1983**, by this Order declares that the bodies specified below are rail freight operators for the purposes of the **Transport (Compliance and Miscellaneous) Act 1983**:

1. Alstom Limited (ACN 000 038 237);
2. Aurizon Operations Limited (ACN 124 649 967);
3. Coleman Rail Pty Ltd (ACN 101 299 512);
4. Downer EDI Rail Pty Ltd (ACN 000 002 031);
5. Downer EDI Works Pty Ltd (ACN 008 709 608);
6. Gemco Rail Pty Ltd (ACN 079 764 444);
7. Genesee & Wyoming Australia Pty Ltd (ACN 079 444 296);
8. Holdco Holdings Pty Ltd (ACN 065 295 016);
9. Interail Australia Pty Ltd (ACN 087 619 010);
10. John Holland Pty Ltd (ACN 004 282 268);
11. Leighton Contractors Pty Ltd (ACN 000 893 667);
12. McConnell Dowell Constructors (Aust) Pty Ltd (ACN 002 929 017);
13. Pacific National Pty Ltd (ACN 098 060 550);
14. Patrick Portlink Pty Limited (ACN 072 506 891);
15. Qube Logistics (Rail) Pty Ltd (ACN 082 313 415);
16. Saddleirs Transport Co (NSW) Pty Ltd (ACN 000 936 194);
17. Speno Rail Maintenance Australia Pty Ltd (ACN 009 206 722);
18. Thiess Pty Ltd (ACN 010 221 486); and
19. Twentieth Super Pace Nominees Pty Ltd (ACN 005 855 327).

This Order comes into effect on 27 June 2015.

Dated 23 June 2015

Responsible Minister:
HON JACINTA ALLAN MP
Minister for Public Transport

YVETTE CARISBROOKE
Clerk of the Executive Council

Occupational Health and Safety Act 2004
Workplace Injury Rehabilitation and Compensation Act 2013

ORDER APPROVING PERSONS OR BODIES FOR THE PURPOSES OF SECTION 11 OF THE **OCCUPATIONAL HEALTH AND SAFETY ACT 2004** AND SECTION 595(2)(d) OF THE **WORKPLACE INJURY REHABILITATION AND COMPENSATION ACT 2013**

Order in Council

The Governor in Council, under section 11(1)(d)(v) of the **Occupational Health and Safety Act 2004**, approves the following persons or bodies for the purposes of section 11 of the **Occupational Health and Safety Act 2004** –

- The Environment Protection Authority Victoria
- The Chair of the Ministerial Advisory Committee also known as the Former Lands Department Chemical Use Independent Inquiry
- the Ministerial Advisory Committee also known as the Former Lands Department Chemical Use Independent Inquiry

The Governor in Council, under Item 16 of Schedule 8 of the **Workplace Injury Rehabilitation and Compensation Act 2013**, approves the following persons or bodies for the purposes of section 595(2)(d) of the **Workplace Injury Rehabilitation and Compensation Act 2013** –

- Victoria Police
- The Director of Public Prosecutions
- The Chair of the Ministerial Advisory Committee also known as the Former Lands Department Chemical Use Independent Inquiry
- the Ministerial Advisory Committee also known as the Former Lands Department Chemical Use Independent Inquiry

This Order comes into effect on the date it is published in the Government Gazette.

Dated 23 June 2015

Responsible Minister:
ROBIN SCOTT, MP
Minister for Finance

YVETTE CARISBROOKE
Clerk of the Executive Council

**SUBORDINATE LEGISLATION ACT 1994
NOTICE THAT STATUTORY RULES ARE
OBTAINABLE**

Notice is hereby given under section 17(3) of the **Subordinate Legislation Act 1994** that the following Statutory Rules were first obtainable from SAI Global Bookshop, 85 Buckhurst Street, South Melbourne, on the date specified:

- | | | | |
|-------------------------------|--|-------------------------------|--|
| 51. <i>Statutory Rule:</i> | Legal Profession Revocation Regulations 2015 | 55. <i>Statutory Rule:</i> | Gambling Regulations 2015 |
| <i>Authorising Act:</i> | Legal Profession Act 2004 | <i>Authorising Act:</i> | Gambling Regulation Act 2003 |
| <i>Date first obtainable:</i> | 24 June 2015 | <i>Date first obtainable:</i> | 24 June 2015 |
| <i>Code A</i> | | <i>Code E</i> | |
| 52. <i>Statutory Rule:</i> | Legal Profession Uniform Law Application Regulations 2015 | 56. <i>Statutory Rule:</i> | Liquor Control Reform Amendment Regulations 2015 |
| <i>Authorising Act:</i> | Legal Profession Uniform Law Application Act 2014 | <i>Authorising Act:</i> | Liquor Control Reform Act 1998 |
| <i>Date first obtainable:</i> | 24 June 2015 | <i>Date first obtainable:</i> | 24 June 2015 |
| <i>Code B</i> | | <i>Code A</i> | |
| 53. <i>Statutory Rule:</i> | Legal Profession Uniform Law Application (Savings and Transitional) Regulations 2015 | 57. <i>Statutory Rule:</i> | Liquor Control Reform (Prohibition of Supply of Powdered Alcohol) Regulations 2015 |
| <i>Authorising Act:</i> | Legal Profession Uniform Law Application Act 2014 | <i>Authorising Act:</i> | Liquor Control Reform Act 1998 |
| <i>Date first obtainable:</i> | 24 June 2015 | <i>Date first obtainable:</i> | 24 June 2015 |
| <i>Code A</i> | | <i>Code A</i> | |
| 54. <i>Statutory Rule:</i> | Estate Agents (Exemption) Amendment Regulations 2015 | 58. <i>Statutory Rule:</i> | Liquor Control Reform (Wholesale Liquor Supply Information) Regulations 2015 |
| <i>Authorising Act:</i> | Estate Agents Act 1980 | <i>Authorising Act:</i> | Liquor Control Reform Act 1998 |
| <i>Date first obtainable:</i> | 24 June 2015 | <i>Date first obtainable:</i> | 24 June 2015 |
| <i>Code A</i> | | <i>Code A</i> | |
| | | 59. <i>Statutory Rule:</i> | Cemeteries and Crematoria Regulations 2015 |
| | | <i>Authorising Act:</i> | Cemeteries and Crematoria Act 2003 |
| | | <i>Date first obtainable:</i> | 24 June 2015 |
| | | <i>Code D</i> | |

-
60. *Statutory Rule:* Subordinate
Legislation
(Private Security
Regulations 2005)
Extension
Regulations 2015
- Authorising Act:* Subordinate
Legislation
Act 1994
- Date first obtainable:* 24 June 2015
Code A
61. *Statutory Rule:* Road Management
(Works and
Infrastructure)
Regulations 2015
- Authorising Act:* Road Management
Act 2004
- Date first obtainable:* 24 June 2015
Code B
62. *Statutory Rule:* Road Safety
(General)
Amendment
(Application
of Fees)
Regulations 2015
- Authorising Act:* Road Safety
Act 1986
- Date first obtainable:* 24 June 2015
Code A
63. *Statutory Rule:* Audit
(Public Bodies)
Regulations 2015
- Authorising Act:* Audit Act 1994
- Date first obtainable:* 24 June 2015
Code A
-

PRICING FOR SPECIAL GAZETTE, PERIODICAL GAZETTE AND VICTORIAN LEGISLATION

Retail price varies according to the number of pages in each Victoria Government Special Gazette, Victoria Government Periodical Gazette and Victorian legislation. The table below sets out the prices that apply.

<i>Price Code</i>	<i>No. of Pages (Including cover and blank pages)</i>	<i>Price*</i>	<i>Price Code</i>	<i>No. of Pages (Including cover and blank pages)</i>	<i>Price*</i>
A	1–16	\$4.00	#Z	1407–1470	\$119.05
B	17–32	\$6.00	#ZA	1471–1536	\$124.70
C	33–48	\$8.20	#ZB	1537–1610	\$129.45
D	49–96	\$12.90	#ZC	1611–1666	\$134.90
E	97–144	\$16.60	#ZD	1667–1730	\$140.00
F	145–192	\$19.70	#ZE	1731–1796	\$145.65
G	193–240	\$22.70	#ZF	1797–1860	\$150.90
H	241–288	\$24.10	#ZG	1861–1926	\$155.85
I	289–352	\$27.20	#ZH	1927–1990	\$161.50
J	353–416	\$31.70	#ZI	1991–2056	\$166.60
K	417–480	\$36.20			
L	481–544	\$42.20			
M	545–608	\$48.25			
N	609–672	\$53.35			
O	673–736	\$60.30			
P	737–820	\$66.45			
#Q	821–886	\$72.25			
#R	887–950	\$77.05			
#S	951–1016	\$82.30			
#T	1017–1080	\$87.40			
#U	1081–1146	\$92.65			
#V	1147–1210	\$98.10			
#W	1211–1276	\$103.20			
#X	1277–1340	\$108.80			
#Y	1341–1406	\$113.70			

* All prices include GST

Printed as two volumes

bluestar **PRINT**

The *Victoria Government Gazette* is published by Blue Star Print with the authority of the Government Printer for the State of Victoria

© State of Victoria 2015

This publication is copyright. No part may be reproduced by any process except in accordance with the provisions of the Copyright Act.

Address all enquiries to the Government Printer for the State of Victoria

Level 2, 1 Macarthur Street
Melbourne 3002
Victoria Australia

How To Order



Retail & Mail Sales

Victoria Government Gazette
Level 5, 460 Bourke Street
Melbourne 3000

PO Box 1957 Melbourne 3001

DX 106 Melbourne



Telephone

(03) 8523 4601



Fax

(03) 9600 0478

email

gazette@bluestargroup.com.au

Recommended Retail Price \$2.10 (includes GST)