



Victoria Government Gazette

No. S 571 Friday 27 December 2019
By Authority of Victorian Government Printer

Transport Integration Act 2010

TRANSFER OF PROPERTY, RIGHTS AND LIABILITIES FROM THE ROADS CORPORATION TO THE SECRETARY TO THE DEPARTMENT OF TRANSPORT PURSUANT TO SECTION 66B OF THE **TRANSPORT INTEGRATION ACT 2010**

Order in Council

The Governor in Council under section 66B of the **Transport Integration Act 2010** orders that the property, rights and liabilities of the Roads Corporation specified or described in the Schedule to this Order be transferred to the Secretary to the Department of Transport on behalf of the Crown.

This Order takes effect on 1 January 2020 (being the transfer date).

This Order may be cited as the Transfer Order (Roads Corporation) No. 1/2020.

Dated 23 December 2019

Responsible Ministers:

HON TIM PALLAS MP

Treasurer

HON JACINTA ALLAN MP

Minister for Transport Infrastructure

ANDREW ROBINSON
Acting Clerk of the Executive Council

SCHEDULE

TRANSFER ORDER (ROADS CORPORATION) NO. 1/2020

1. Description of property, rights and liabilities

All property, rights and liabilities of VicRoads, (including:

- (a) Records; and
- (b) Book Debts and Prepayments,

existing in or relating to the following:

- (a) Assets;
- (b) Contracts;
- (c) Intellectual Property;
- (d) Land; and
- (e) Liabilities.

2. Definitions

Expressions used in this Order have the meaning given to them in sections 3 and 66A of the **Transport Integration Act 2010**. In addition, unless the context otherwise requires:

Assets means the assets described in Annexure A and all other assets used solely or predominately in the performance of the Registration and Licensing Functions.

Book Debts and Prepayments means the amounts owing or due to VicRoads by trade and other debtors and prepayments by VicRoads to suppliers of goods and services to VicRoads.

Contracts means

- (a) all agreements or arrangements described or listed in Annexure B or in a category described in Annexure B; and

SPECIAL

- (b) all other agreements or arrangements (not including agreements or arrangements for the employment of staff) which relate solely or predominately to the performance of the Registration and Licensing Functions and which were entered into by or on behalf of VicRoads or to which VicRoads is a party or under which VicRoads has any rights or liabilities,

including Expired Contracts, together with:

- (c) all bank guarantees and security deposits held by VicRoads or to which VicRoads is entitled in respect of those agreements; and
- (d) all rights or interest under any insurance policy relating to those agreements, each as amended, supplemented or novated from time to time.

Expired Contracts means all agreements or arrangements described or listed in Annexure B or in a category described in Annexure B or which otherwise relate solely or predominately to the performance of the Registration and Licensing Functions and which were entered into by or on behalf of VicRoads or to which VicRoads is a party or under which VicRoads has any rights or liabilities, that have expired or been terminated.

Intellectual Property means all the:

- (e) Intellectual Property Rights described in Annexure C to this Order;
- (f) agreements relating to any right to use, or exercise the rights in, the Intellectual Property Rights in paragraph (a); and
- (g) other:
 - (i) Intellectual Property Rights; and
 - (ii) agreements relating to any right to use, or to exercise the rights in, the Intellectual Property Rights,
 which relate solely or predominately to the property, rights and liabilities transferred under this Order.

Intellectual Property Rights includes without limitation all:

- (h) copyright and neighbouring rights, all proprietary rights in relation to inventions (including patents) and processes, trademarks (including goodwill), confidential information (including trade secrets and know how), designs, circuit layouts, trade names, business names and domain names;
- (i) other proprietary rights resulting from intellectual activity in the industrial, scientific, literary or artistic fields;
- (j) in respect of paragraphs (a) and (b), above, whether the rights are:
 - (i) recognised as existing at law;
 - (ii) protected by statute, common law or in equity;
 - (iii) registered, unregistered or applied for; or
 - (iv) subject to renewals or extensions, in Australia, or anywhere else in the world; and
- (k) rights or remedies against any infringement of the rights specified in paragraphs (a), (b) or (c), above.

Land means the land described in Annexure D, whether Crown land or land alienated from the Crown, including without limitation any:

- (l) interests, tenures and estates in that land; and
- (m) fixtures and fittings on that land as applicable.

Liabilities means those liabilities described in Annexure E and all other liabilities which relate solely or predominately to the Registration and Licensing Functions.

Records means all files, records and data and all other documents.

Registration and Licensing Functions means those functions of VicRoads that have been assumed by the Secretary to the Department of Transport pursuant to the **Transport Legislation Amendment Act 2019**.

VicRoads means the Roads Corporation, established under the **Transport Act 1983** and continued under the **Transport Integration Act 2010**.

TRANSFER ORDER (ROADS CORPORATION) NO. 1/2020
ANNEXURE A – ASSETS

1. All assets in the following categories

Category

Breathalysers
Card payment devices
Customer queue management systems
Money counters
PC EFTPOS IP communications gateways
Petrol and oil interceptors
Point of sale hardware and software
Point of sale printers
Security systems at customer service centres
Stationary and directional radar speed guns
Window tint meters

2. Assets in the following categories that are not used solely or predominately to perform the functions of VicRoads assumed by Head, Transport for Victoria pursuant to the **Transport Legislation Amendment Act 2019**

Category

Data storage systems, arrays, tape libraries and associated hardware and software
Defibrillators
Electronic appliance testers
Fire and other emergency management equipment
GPS devices
Handheld cameras
Measuring scales
Power distribution units, racks and coolers
Satellite phones
Security cameras
Storage containers, filing and shelving
Uninterruptable power supply systems and associated equipment
VPN applications
Work lights, torches and LED lights





TRANSFER ORDER (ROADS CORPORATION) NO. 1/2020
ANNEXURE B – CONTRACTS

Category or agreement	
1.	Registration and licensing
a.	Goods or services procured by VicRoads
i.	Agreements relating to the L2P learner driver mentor program
ii.	Agreements relating to provision of specialist medical advice services to VicRoads for registration and licensing purposes
iii.	Agreements relating to provision of ICT services or software to VicRoads for registration and licensing
iv.	Agreements relating to the myLearners app
v.	Panel contract arrangements for interpretation and translation services to VicRoads
vi.	Agreements relating to provision of alcohol interlock programs and equipment for VicRoads
vii.	Agreements for the manufacture, supply and distribution of number plates for VicRoads
viii.	Agreements relating to provision of warehousing and distributing services to VicRoads for VicRoads' registration and licensing forms and publications
ix.	Professional services and consultancy agreements relating to Registration and Licensing Functions, including legal services
x.	Agreements relating to research projects and data collection for VicRoads about Registration and Licensing Functions
xi.	Agreements relating to provision of mail sorting, processing and data imaging services to VicRoads for registration and licensing purposes
b.	Customer Services Centres (CSC) and Licence Testing Centres (LTC)
i.	Goods or services procured by VicRoads
1.	Agreements relating to provision of ICT services or software to VicRoads to assist with customer management at CSCs and LTCs
ii.	Land
1.	Leases of land currently used as a CSC at Ararat, Bundoora, Cobram, Colac, Dandenong South, Dromana, Echuca, Hamilton, Heatherton, Hoppers Crossing, Leongatha, Melbourne CBD, Melton, Mildura (Orange Avenue), Mildura (Risbey Lane), Portland, Sale, Seaford, Seymour, Sunbury, Swan Hill, Wangaratta and Warragul (with VicRoads as lessee)
2.	Leases of land currently used as a LTC at Deer Park, Mooroolbark, Pakenham and Werribee (with VicRoads as lessee)
3.	Agreements relating to the proposed Ringwood Customer Services Centre and Regional Office
4.	Licences to VicRoads in relation to VicRoads office accommodation, CSC or LTC, including a car parking licence
5.	Agreements for VicRoads to use land for the provision of vehicle inspection bays at a CSC or LTC

Category or agreement	
c.	Certified or accredited private providers
i.	Agreements relating to certification or accreditation of vehicle dealers, inspectors or testers
ii.	Agreements relating to certification or accreditation of motorcycle testing and training providers
iii.	Agreements relating to certification or accreditation of heavy vehicle testing and training providers
d.	Fees, charges and taxes
i.	Agreements relating to registration and licensing fees, charges and taxes
ii.	Agreements with the Transport Accident Commission (TAC) about collection of the TAC charge
e.	Miscellaneous
i.	Agreements relating to access to licensing and registration data, including Information Protection Agreements under Part 7B of the Road Safety Act 1986
ii.	Agreements for VicRoads to pay compensation relating to disputes about registration and licensing matters
2. Education	
a.	Goods or services procured by VicRoads
i.	Agreements relating to provision of driver and road safety education programs for VicRoads
ii.	Panel contract arrangements for providing the Safe Driving Program for VicRoads
iii.	Agreements relating to provision of ICT services or software to VicRoads about driver education
b.	Funding
i.	Agreements with Transport Accident Commission about funding driver education and training programs
ii.	Agreements with Transport Accident Commission about road user behaviour
iii.	Agreements for VicRoads to grant funding for community road safety programs
iv.	Insurance policy for community road safety grants
3. Miscellaneous	
a.	Agreements for VicRoads to grant funding relating to Registration and Licensing Functions
b.	Agreements with toll road operators relating to powers of authorised officers under sections 134(4), 134A(4) and 134D(4) of the Road Management Act 2004
c.	Agreements about services provided by VicRoads International
d.	Agreements with the National Heavy Vehicle Regulator
e.	Panel contract arrangements for engineering services to VicRoads
f.	Agreements relating to the National Driver Licence Facial Recognition Solution

**TRANSFER ORDER (ROADS CORPORATION) NO. 1/2020
ANNEXURE C – INTELLECTUAL PROPERTY**

1. Trade marks

Identifier	Device
791431	VIC ROADS 
814097	KEYS PLEASE
814098	CRASHSTATS
814100	CRASHSTATS 
956469	ThingleToodle
959578	TT 
1138407	SAFECARS SAVELIVES 
1138408	Not all cars are created equal
1138409	BING
1138410	

1197971



1258648

SAFECARS SAVE LIVES



1316383

CGT



1316386

CityGT

1325242

V VIC ROADS



1325243

V



1538321

VPLATES

1659703

V VIC ROADS CUSTOM PLATES



1835335

ROAD SMART

489764

.05



489765

.05



489766

.05



489767

.05



489768

.05



489769

.05



489770

.05



myvicroads

myVicRoads



myLearners

2. Internet domains

Identifier

mylearners.vic.gov.au

roads.vic.gov.au

arrivealive.vic.gov.au

vicroads.vic.gov.au

vplates.com.au

roadsafetyeducation.vic.gov.au

sandownvipcomp.com

travelhappy.vic.gov.au

sharetheroad.vic.gov.au

customaffinal.com

vicroads-pmte.com

vicroads-prep.com

vicroads-myro.com

3. Other unregistered intellectual property

Description

Any unregistered Intellectual Property Rights in the layout and arrangement of Victorian driver licences of all classes

Any Intellectual Property Rights licensed to VicRoads in the security aspects of the layout and arrangement of Victorian driver licences of all classes

Any unregistered Intellectual Property Rights VicRoads owns in the layout and arrangement of Victorian number plates of all classes

Any unregistered Intellectual Property Rights owned by VicRoads in the 'myLearners' software application

4. Business names

Business name

THE L SITE

5. Trading names

Trading name

Information Services

**TRANSFER ORDER (ROADS CORPORATION) NO. 1/2020
ANNEXURE D – LAND**

Land	Street Address	Land description
Bairnsdale Customer Service Centre and Regional Office	535 Princes Highway, Bairnsdale Vic 3875	Lot 1 on TP125765 and Crown Allotment 5A, Section B, Township of Bairnsdale (SPI 5A~B\PP5027)
Benalla Customer Service Centre and Regional Office	48–52 Clarke St, Benalla Vic 3672	PC350178
Broadmeadows Customer Service Centre	2–8 Pearcedale Parade, Broadmeadows Vic 3047	Lot 1 on TP920658
Carlton Customer Service Centre	459 Lygon St, Carlton Vic 3053	Crown Allotment 25, Section 59, Parish of Jika Jika (SPI 25~59\ PP2796B)
Kyneton Customer Service Centre, Regional Office and Road Services Depot	2 Beauchamp St, Kyneton Vic 3444	Lot 1 on PS546458
Morwell Customer Service Centre	83–87 Princes Drive, Morwell Vic 3840	Crown Allotment 45M, Parish of Maryvale (SPI 45M\PP3072)
Shepparton Customer Service Centre	231–239 Corio St, Shepparton Vic 3630	Crown Allotment 1, Section 13A, Parish of Shepparton (SPI 1~13A\ PP5713) and Crown Allotment 2, Section 13A, Parish of Shepparton (SPI 2~13A\ PP5713)
Warrnambool Customer Service Centre, SprayLine Depot and Regional Office	29 Jamieson St, Warrnambool Vic 3280	Lot 2 on LP138299
Wodonga Customer Service Centre	82–86 Elgin Blvd, Wodonga Vic 3690	Lot 1 on TP534013 and Lot 1 on LP46544

**TRANSFER ORDER (ROADS CORPORATION) NO. 1/2020
ANNEXURE E – LIABILITIES**

Description

Any liability of VicRoads arising out of an action for negligence, where the liability relates solely or predominately to the Registration and Licensing Functions

Transport Integration Act 2010

TRANSFER OF PROPERTY, RIGHTS AND LIABILITIES FROM THE
ROADS CORPORATION TO THE SECRETARY TO THE DEPARTMENT OF TRANSPORT
PURSUANT TO SECTION 66B OF THE **TRANSPORT INTEGRATION ACT 2010**

Order in Council

The Governor in Council under section 66B of the **Transport Integration Act 2010** orders that the property, rights and liabilities of the Roads Corporation specified or described in the Schedule to this Order be transferred to the Secretary to the Department of Transport on behalf of the Crown.

This Order takes effect on 1 January 2020 (being the transfer date).

This Order may be cited as the Transfer Order (Roads Corporation) No. 2/2020.

Dated 23 December 2019

Responsible Ministers:

HON TIM PALLAS MP

Treasurer

HON JACINTA ALLAN MP

Minister for Transport Infrastructure

ANDREW ROBINSON

Acting Clerk of the Executive Council

SCHEDULE

TRANSFER ORDER (ROADS CORPORATION) NO. 2/2020

1. Description of property, rights and liabilities

All property, rights and liabilities of VicRoads, (including:

- (a) Records; and
 - (b) Book Debts and Prepayments,)
- existing in or relating to the following:

- (a) Assets;
- (b) Contracts;
- (c) Intellectual Property; and
- (d) Land,

except for the Excluded Property.

2. Definitions

Expressions used in this Order have the meaning given to them in sections 3 and 66A of the **Transport Integration Act 2010**. In addition, unless the context otherwise requires:

Assets means the assets described in Annexure A.

Book Debts and Prepayments means the amounts owing or due to VicRoads by trade and other debtors and prepayments by VicRoads to suppliers of goods and services to VicRoads.

Contracts means all agreements or arrangements described or listed in Annexure B or in a category described in Annexure B, including Expired Contracts, together with:

- (a) all bank guarantees and security deposits held by VicRoads or to which VicRoads is entitled in respect of those agreements; and
 - (b) all rights or interest under any insurance policy relating to those agreements,
- each as amended, supplemented or novated from time to time.

Excluded Property means property, rights and liabilities that are transferred to the Secretary pursuant to Transfer Order (Roads Corporation) No. 1/2020 made on the date of this Order.

Expired Contracts means all agreements or arrangements described or listed in Annexure B or in a category described in Annexure B and which were entered into by or on behalf of VicRoads or to which VicRoads is a party or under which VicRoads has any rights or liabilities, that have expired or been terminated.

Intellectual Property means all the:

- (c) Intellectual Property Rights; and
- (d) agreements relating to any right to use, or to exercise the rights in, the Intellectual Property Rights,

which relate solely or predominately to the property, rights and liabilities transferred under this Order.

Intellectual Property Rights includes without limitation all:

- (e) copyright and neighbouring rights, all proprietary rights in relation to inventions (including patents) and processes, trademarks (including goodwill), confidential information (including trade secrets and know how), designs, circuit layouts, trade names, business names and domain names;
- (f) other proprietary rights resulting from intellectual activity in the industrial, scientific, literary or artistic fields.;
- (g) in respect of paragraphs (a) and (b), above, whether the rights are:
 - (i) recognised as existing at law;
 - (ii) protected by statute, common law or in equity;
 - (iii) registered, unregistered or applied for; or
 - (iv) subject to renewals or extensions, in Australia, or anywhere else in the world; and
- (h) rights or remedies against any infringement of the rights specified in paragraphs (a), (b) or (c), above.

Land means the land described in Annexure C, whether Crown land or land alienated from the Crown, including without limitation any:

- (i) interests, tenures and estates in that land; and
- (j) fixtures and fittings on that land as applicable.

Records means all files, records and data and all other documents.

VicRoads means the Roads Corporation, established under the **Transport Act 1983** and continued under the **Transport Integration Act 2010**.

TRANSFER ORDER (ROADS CORPORATION) NO. 2/2020
ANNEXURE A – ASSETS

1. All assets in the following categories

Category
Antivirus computer software
Artwork and office decorations
Audio visual equipment including recording equipment and projectors
Barcode scanners
CD/DVD and stereo recorders and players
CD/DVD burners
Coffee machines
Commercial food mixers
Cool rooms
Cordless telephones
Digital photo frames
Document shredders
Electronic whiteboards and whiteboards
Gymnasium and fitness related equipment
Hot plates
Hot water dispensers and kettles and water chillers
Image archives
IT applications delivery control platforms
IT systems data tracking and access software
Labelling machines and laminators
Mail carts
Microwaves, ovens, toasters and stoves and other cooking equipment
Mobile telephones
Music production software
Office cleaning equipment and dishwashers
Office furniture
Office heating and cooling
Office printers, fax machines and scanners
Office sick bay equipment and supplies
PABX telephone systems and other office communication systems
Portable/external hard drives
Prayer/meditation room equipment and supplies
Refrigerators
Safes
Serveries and bain maries

Category

Shower equipment

Speakers and headsets

Stationery and office supplies

Tablets and iPods

Televisions

Trolleys - office storage

Video recorders

Water filters

Wireless modems

2. Assets in the following categories that are not used solely or predominately to perform the functions of VicRoads assumed by Head, Transport for Victoria pursuant to the **Transport Legislation Amendment Act 2019**

Category

Computer cables

Computer monitors

Computer network hardware

Computer servers

Consoles and docking stations

Desktop computers and associated hardware

Laptop computers and associated hardware

TRANSFER ORDER (ROADS CORPORATION) NO. 2/2020
ANNEXURE B – CONTRACTS

Category or agreement

1. General ICT systems for the whole of VicRoads

- a. Agreements relating to provision of ICT services or software to VicRoads for VicRoads' ICT systems and security
- b. Agreements relating to provision of ICT services or software to VicRoads regarding VicRoads' website
- c. Agreements relating to provision of telecommunication goods and services to VicRoads
- d. Agreements relating to provision of ICT services or software to VicRoads about asset management

2. Corporate Services

- a. Agreements relating to provision of banking services to VicRoads
- b. Agreements relating to provision of records management services to VicRoads
- c. Equipment hire agreements for printing services to VicRoads
- d. Professional services and consultancy agreements to VicRoads relating to VicRoads corporate, including legal, accounting and auditing services
- e. Agreements relating to provision of strategic communication services to VicRoads
- f. Agreements relating to provision of advertising and media services to VicRoads except about road infrastructure
- g. Agreements relating to provision of catering services to VicRoads

3. Human Resources

- a. Agreements relating to provision of agency staff and secondments to VicRoads
- b. Agreements relating to provision of ICT services or software to VicRoads about human resources
- c. Agreements relating to provision of ICT services or software to VicRoads about health, safety and the environment for VicRoads corporate
- d. Agreements relating to provision of uniforms to VicRoads
- e. Agreements relating to provision of services to VicRoads for drug and alcohol testing of VicRoads staff and contractors
- f. Agreements relating to provision of employee assistance programs to VicRoads
- g. Agreements relating to provision of corporate training to VicRoads
- h. Agreements relating to provision of corporate travel services to VicRoads

4. Office accommodation

a. Goods or services procured by VicRoads

- i. Agreements relating to provision of goods or services to VicRoads for VicRoads offices
- ii. Agreements relating to provision of property management services except for the former Department of Economic Development, Jobs, Transport and Resources properties

Category or agreement	
b.	Land
i.	Licences granted by VicRoads at VicRoads' Kew office
ii.	Leases of land currently used for office accommodation at 1 Spring St Melbourne, 60 Denmark St Kew, and 80A Learmonth Rd, Wendouree (with VicRoads as lessee)
iii.	Leases of land currently used as a customer services centre and office accommodation at Bendigo, Burwood East, Geelong (Fyans St), Horsham, Sunshine, and Wendouree (88 Learmonth Rd) (with VicRoads as lessee)
5.	Vehicles
a.	Leases of vehicles to VicRoads
b.	Agreements relating to provision of fuel to VicRoads
6.	Agreements with State and Federal agencies
a.	Inter-departmental/agency shared services agreements
b.	Agreements relating to provision by VicRoads of corporate support, staff or shared services in conjunction with major transport infrastructure projects
c.	Agreements relating to provision of funding by VicRoads to AusRoads
d.	Agreements relating to provision of funding by VicRoads to interstate road agencies

**TRANSFER ORDER (ROADS CORPORATION) NO. 2/2020
ANNEXURE C – LAND**

Land	Street Address	Land description
Traralgon Regional Office	116–128 Kay St, Traralgon Vic 3844	Lot 1 on TP226588

Transport Integration Act 2010**TRANSFER OF PROPERTY, RIGHTS AND LIABILITIES FROM THE
ROADS CORPORATION TO THE HEAD, TRANSPORT FOR VICTORIA
PURSUANT TO SECTION 66B OF THE TRANSPORT INTEGRATION ACT 2010**

Order in Council

The Governor in Council under section 66B of the **Transport Integration Act 2010** orders that the property, rights and liabilities of the Roads Corporation specified or described in the Schedule to this Order be transferred to the Head, Transport for Victoria.

This Order takes effect on 1 January 2020 (being the transfer date).

This Order may be cited as the Transfer Order (Roads Corporation) No. 3/2020.

Dated 23 December 2019

Responsible Ministers:

HON TIM PALLAS MP

Treasurer

HON JACINTA ALLAN MP

Minister for Transport Infrastructure

ANDREW ROBINSON
Acting Clerk of the Executive Council

SCHEDULE**TRANSFER ORDER (ROADS CORPORATION) NO. 3/2020****1. Description of property, rights and liabilities**

All property, rights and liabilities of VicRoads (including:

- (a) Records; and
 - (b) Book Debts and Prepayments),
- existing in or relating to the following:
- (c) Assets;
 - (d) Contracts;
 - (e) Cultural Heritage Management Plans;
 - (f) Intellectual Property;
 - (g) Land; and
 - (h) Liabilities,

except for the Excluded Property.

2. Definitions

Expressions used in this Order have the meaning given to them in sections 3 and 66A of the **Transport Integration Act 2010**. In addition, unless the context otherwise requires:

Assets means:

- (a) the assets described in Annexure A and all other assets used solely or predominately in the performance of the Road Management Functions;
- (b) water shares (issued under the **Water Act 1989**);
- (c) native title vegetation offset credits; and
- (d) funds held on trust for VicRoads with Trust for Nature (Victoria).

Book Debts and Prepayments means the amounts owing or due to VicRoads by trade and other debtors and prepayments by VicRoads to suppliers of goods and services to VicRoads.

Contracts means:

- (a) all agreements or arrangements described or listed in Annexure B or in a category described in Annexure B; and
- (b) all other agreements or arrangements which relate solely or predominantly to the performance of the Road Management Functions and which were entered into by or on behalf of VicRoads or to which VicRoads is a party or under which VicRoads has any rights or liabilities,

including Expired Contracts, together with:

- (c) all bank guarantees and security deposits held by VicRoads or to which VicRoads is entitled in respect of those agreements; and
- (d) all rights or interest under any insurance policy relating to those agreements, each as amended, supplemented or novated from time to time.

Cultural Heritage Management Plans means cultural heritage management plans issued under the **Aboriginal Heritage Act 2006**.

Excluded Property means:

- (a) agreements or arrangements for the employment of staff;
- (b) property, rights and liabilities that are transferred to the Secretary pursuant to Transfer Order (Roads Corporation) No. 1/2020 made on the date of this Order; and
- (c) property, rights and liabilities that are transferred to the Secretary pursuant to Transfer Order (Roads Corporation) No. 2/2020 made on the date of this Order.

Expired Contracts means all agreements or arrangements described or listed in Annexure B or in a category described in Annexure B or which otherwise relate solely or predominately to the performance of the Road Management Functions and which were entered into by or on behalf of VicRoads or to which VicRoads is a party or under which VicRoads has any rights or liabilities, that have expired or been terminated.

Intellectual Property means all the:

- (a) Intellectual Property Rights described in Annexure C to this Order;
- (b) agreements relating to any right to use, or exercise the rights in, the Intellectual Property Rights in paragraph (a); and
- (c) other:
 - (i) Intellectual Property Rights; and
 - (ii) agreements relating to any right to use, or to exercise the rights in, the Intellectual Property Rights,

which relate solely or predominantly to the property, rights and liabilities transferred under this Order.

Intellectual Property Rights includes without limitation all:

- (a) copyright and neighbouring rights, all proprietary rights in relation to inventions (including patents) and processes, trademarks (including goodwill), confidential information (including trade secrets and know how), designs, circuit layouts, trade names, business names and domain names;
- (b) other proprietary rights resulting from intellectual activity in the industrial, scientific, literary or artistic fields.;
- (c) in respect of paragraphs (a) and (b), above, whether the rights are:
 - (i) recognised as existing at law;
 - (ii) protected by statute, common law or in equity;

- (iii) registered, unregistered or applied for; or
- (iv) subject to renewals or extensions,
in Australia, or anywhere else in the world; and
- (d) rights or remedies against any infringement of the rights specified in paragraphs (a), (b) or (c), above.

Land means all land, including without limitation all:

- (a) Crown land and land alienated from the Crown;
- (b) interests, tenures and estates in land; and
- (c) fixtures and fittings on that land as applicable.

Liabilities means those liabilities described in Annexure D and all other liabilities which relate solely or predominately to the Road Management Functions.

Records means all files, records and data and all other documents.

Road Management Functions means those functions of VicRoads that have been assumed by Head, Transport for Victoria pursuant to the **Transport Legislation Amendment Act 2019**.

VicRoads means the Roads Corporation, established under the **Transport Act 1983** and continued under the **Transport Integration Act 2010**.

TRANSFER ORDER (ROADS CORPORATION) NO. 3/2020**ANNEXURE A – ASSETS**

1. All assets in the following categories

Category
Assets associated with SCAT system
Balance benches
Boats, boat motors and accessories
Climatic test chambers
Compasses
Dash cams
Eye wash and body spray cleaning systems
Gas detectors
Generators, power packs and engines
Information, distance and data gathering equipment
Jump starters
Ladders
Land survey equipment
Laser pointers
Lawn mowers and lawn maintenance equipment
Lightbulbs
Microscopes and viewing instruments
Oscilloscopes
Polarimeters
Portable traffic lights and beacons
Pumps and pump accessories
Radio equipment
Road construction/maintenance/line-marking consumables
Road construction/maintenance/line-marking equipment, tools and accessories
Road construction/maintenance/line-marking machinery
Road construction/maintenance/line-marking office, shelter and ablution sheds and portable buildings
Road construction/maintenance/line-marking vehicles and trailers
Road fencing
Road fencing equipment
Scram cabins
Search lights
Security systems at road maintenance/constructions depots and site offices
Shipping containers
Steel posts, scaffolding, barriers and other materials

Category

Storage tanks and related accessories

Sydney Coordinated Adaptive Traffic System test computer

Temporary speed humps

Thermometers

Timelapse and action cameras

Trade waste systems

Traffic counters

Traffic management equipment

Traffic management software

Traffic survey systems and equipment

Trolleys - road construction and maintenance

Turbine flowmeters

Variable message/directional/speed sign boards and trailers

Vehicle parts and systems

Vehicles

Water baths

Wayphones and wayphone testers

WebCams

2. Assets in the following categories that are used solely or predominately in the performance of the Road Management Functions

Category

Computer cables

Computer monitors

Computer network hardware

Computer servers

Consoles and docking stations

Data storage systems, arrays, tape libraries and associated hardware and software

Defibrillators

Desktop computers and associated hardware

Electronic appliance testers

Fire and other emergency management equipment

GPS devices

Handheld cameras

Laptop computers and associated hardware

Measuring scales

Power distribution units, racks and coolers

Satellite phones

Category

Security cameras

Storage containers, filing and shelving

Uninterruptable power supply systems and associated equipment

VPN applications

Work lights, torches and LED lights

TRANSFER ORDER (ROADS CORPORATION) NO. 3/2020
ANNEXURE B – CONTRACTS





Category or agreement	
1.	Roads, road infrastructure and road projects
a.	General
i.	Agreements relating to design, construction and maintenance of roads and road infrastructure
ii.	Agreements made under section 15 of the Road Management Act 2004
iii.	Agreements for VicRoads to pay relating to disputes except disputes relating to registration and licensing
iv.	Insurance policies specific to a road project
b.	Land
i.	Agreements relating to sale and purchase of land (not yet settled)
ii.	Agreements for VicRoads to pay compensation relating to road projects or compulsory acquisition
iii.	Lease of land at 1 McNab Avenue, Footscray (with VicRoads as lessee)
iv.	Licences granted to VicRoads by which VicRoads or its contractor may enter or access land for the purposes of a road project
c.	Goods or services provided by VicRoads
i.	Agreements relating to provision of road construction expertise services by VicRoads
ii.	Agreements relating to provision of land surveying services by VicRoads
d.	Goods or services procured by VicRoads
i.	Agreements relating to provision of goods to VicRoads for road design, construction or maintenance
ii.	Panel contracts for installation of Safe System Road Infrastructure Program infrastructure for VicRoads
iii.	Agreements for equipment hire by VicRoads for road design, construction or maintenance
iv.	Agreements relating to supply of electricity to VicRoads for roads, road projects and street lighting
v.	Agreements relating to professional services and consultancy agreements to VicRoads relating to roads or road projects, including legal services
vi.	Agreements relating to provision of security services to VicRoads for roads, road infrastructure or road depots
vii.	Agreements relating to provision of property management services to VicRoads for the former Department of Economic Development, Jobs, Transport and Resources properties only
viii.	Agreements relating to provision of ICT services or software to VicRoads for road design, construction or maintenance
ix.	Provision of advertising and media services to VicRoads about road infrastructure
x.	Agreements relating to research projects and data collection for VicRoads about roads or road infrastructure

Category or agreement	
e.	Funding
i.	Agreements with Transport Accident Commission about the Safe System Road Infrastructure Program
ii.	Agreements for VicRoads to grant funding related to road infrastructure
f.	Major Transport Infrastructure Authority (MTIA)
i.	Agreements with MTIA for the delivery of road projects by MTIA
ii.	Agreements for the provision of services by VicRoads to MTIA relating to road network planning, road or road-related assets, infrastructure works or VicRoads' road expertise
iii.	Developer agreements in relation to MTIA road projects
iv.	Interface agreements with a utility (including power, gas, water mains and sewers), rail or tram entities in connection with MTIA road projects
2.	Regulating use of road land
a.	Agreements made under section 173 of the Planning and Environment Act 1978
b.	Agreements primarily concerning the creation, sale and/or purchase of native vegetation credits under a State or Federal scheme
c.	Licences granted by VicRoads to advertise on road land
d.	Leases or licences granted by VicRoads under clause 9 of Schedule 5 of the Road Management Act 2004
3.	Toll Roads
a.	Agreements relating to provision of ICT services or software to VicRoads for toll road project documents
b.	Agreements with toll road operators other than those relating to providing registration or licensing details
c.	Agreements relating to the design, construction, maintenance or financing of toll roads
d.	Agreements relating to services centres at freeways or toll ways
4.	Sprayline
a.	Leases of land currently used as a SprayLine Depot at Benalla, Donald, Echuca, Golden Square, Junortoun, Kilmore, Red Cliffs, and Warracknabeal (with VicRoads as lessee)
b.	Agreements relating to provision of goods or services by VicRoads SprayLine
c.	Agreements relating to provision of goods or services to VicRoads SprayLine
d.	Panel contract arrangements for plant and equipment hire to VicRoads SprayLine
e.	Agreements relating to provision of staff to SprayLine
5.	Traffic control
a.	General
i.	Agreements providing access by VicRoads to travel times and usage data
b.	Goods or services procured by VicRoads
i.	Agreements relating to provision of ICT services or software to VicRoads for traffic information systems or road traffic control devices

Category or agreement	
ii.	Agreements relating to provision of goods or services to VicRoads for traffic monitoring or road traffic control devices
iii.	Agreements relating to provision of goods and services to VicRoads for weather monitoring
iv.	Agreements relating to provision of goods or services to VicRoads for towing and impounding
v.	Agreements relating to supply, installation and maintenance of telemetry bicycle counters for VicRoads
c.	Licence of land to use as a snow clearing patrol depot
i.	Agreements made under section 27 of the National Parks Act 1975
ii.	Licences entered into under section 52 of the Forests Act 1958
iii.	Consent Deeds or licences entered into under the Alpine Resorts (Management) Act 1997
iv.	Licences granted to VicRoads for the purpose of operating a snow clearing patrol depot

**TRANSFER ORDER (ROADS CORPORATION) NO. 3/2020
ANNEXURE C – INTELLECTUAL PROPERTY**



1. Trade marks

Identifier	Device
720435	SPRAYLINE
720436	SPRAY LINE
	
413040	RCA
	
	
	
	Regional Roads Victoria
	RRV

2. Internet domains

Identifier
sprayline.com.au
regionalroads.vic.gov.au
transport.vic.gov.au
vrsa.com.au

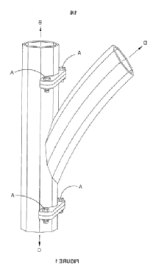
3. Registered designs

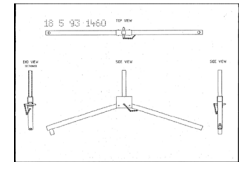
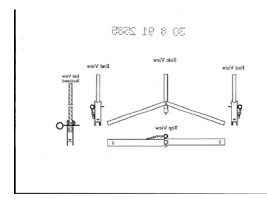
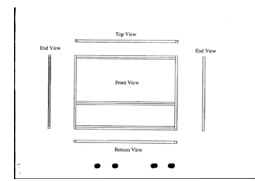
Identifier	Device
346640	Pivotal traffic signal support 
344699	Jig 
120727	
115650	Sign stand 
113935	Folding Sign Frame Stand 

113091

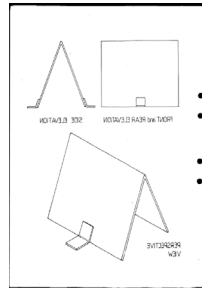

113090

A display sign for mounting on the ground

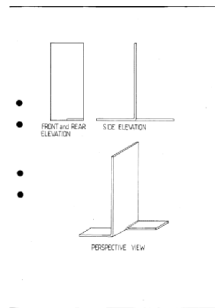

88244

Base Adaptor For A Roadworks Delineator

87753

Roadworks Delineator Head

4. Patents

Identifier	Description
2018201141	Traffic signal support
2013337583	Traffic signal support
2012244338	Traffic signal support
2006200486	Radio Switching Device
1994058297	A hazard perception test system
1993906776	A hazard perception test system
1993036232	Control apparatus for line marking machines
1992901237	Control apparatus for line marking machines
1991904469	Precast bridge erection system
1991070825	A road sign
1991069405	Removable barrier
1990908229	Removable barrier
1990900183	A road sign
1990047575	Apparatus for separating contaminants from refrigerant

1988902025	Apparatus for separating contaminants from refrigerant of vapour compression refrigeration systems
1981074037	INSPECTION DEVICE FOR GROUND HOLES
1980905012	INSPECTION DEVICE FOR GROUND HOLES
1958035401	IMPROVED APPARATUS FOR LOADING AND/OR SCREENING GRAVEL, SCREENINGS AND LIKE MATERIAL
1989033960	Sound absorption barriers
1988908046	Sound absorption barriers
1983022666	LINE MARKING APPARATUS

5. Business or trading names**Business name**SprayLine Road Services

6. Trading names**Trading name**Land Information & Survey

GeoPave

Sprayline

TRANSFER ORDER (ROADS CORPORATION) NO. 3/2020
ANNEXURE D – LIABILITIES

Description

Any liability of VicRoads arising out of the **Planning and Environment Act 1987**, including under sections 98 and 107

Any liability of VicRoads arising out of the issue of a notice of acquisition under the **Land Acquisition and Compensation Act 1986**, including under sections 30, 46 and 47

Any liability of VicRoads as a road authority under the **Road Management Act 2004**

Any liability of VicRoads arising out of an action for negligence, where the liability relates solely or predominately to the Road Management Functions

This page was left blank intentionally

ive

The *Victoria Government Gazette* is published by IVE Group Limited with the authority of the Government Printer for the State of Victoria

© State of Victoria 2019

This publication is copyright. No part may be reproduced by any process except in accordance with the provisions of the Copyright Act.

Address all enquiries to the Government Printer for the State of Victoria
Level 2, 1 Macarthur Street
Melbourne 3002
Victoria Australia

How To Order



Retail & Mail Sales

Victoria Government Gazette

Ground Floor, Building 8,
658 Church Street,
Richmond 3121

DX 106 Melbourne



Telephone

(03) 8523 4601



Fax

(03) 9600 0478

email

gazette@ivegroup.com.au

Price Code C