



# Victoria Government Gazette

No. G 25 Thursday 25 June 1998

**GENERAL**

## GENERAL AND PERIODICAL GAZETTE

Copy to: Gazette Officer  
The Craftsman Press Pty. Ltd.  
125 Highbury Road,  
Burwood Vic 3125  
Telephone: (03) 9926 1233  
Facsimile: (03) 9926 1292  
DX: 32510 Burwood  
Email: [gazette@craftpress.com.au](mailto:gazette@craftpress.com.au)

### Advertising Rates and Payment

#### Private Notices

Payment must be received in advance with advertisement details.

30 cents per word - Full page \$180.00.

Additional costs must be included in prepayment if a copy of the gazette is required. Copy Prices - Page

\$1.50 - Gazette \$3.20 Certified copy of Gazette \$3.50. (all prices include Postage). **Cheques should be made payable to The Craftsman Press Pty. Ltd.**

#### Government and Outer Budget Sector Agencies Notices

Not required to pre-pay.

Advertisements may be faxed or sent via email with a cover sheet, marked to the attention of the Gazette Officer.

Floppy Disks (Mac & PC) can also be accepted.

Costs can be calculated on the following basis:

Per Line	Typeset
Single column	\$1.55
Double column	\$3.10
Full Page	\$64.80

The Craftsman Press is pleased to offer a series of discounts from the typesetting costs.

1. Copy supplied on disk.
2. Copy supplied via email.
3. Artwork for forms and other material which require exact reproduction.

#### 1. Copy supplied on disk.

Where a disk is supplied and there is minimum alteration required, **30% off.**

Where a disk is supplied requiring extraneous matter stripped out and styles applied, **20% off.**

#### 2. Copy supplied via email.

Where a notice is sent via email and there is minimum alteration required, **25% off.**

Where email is supplied requiring extraneous matter stripped out and styles applied, **15% off.**

#### 3. Artwork for forms and other material which requires exact reproduction.

Scanning and sizing of artwork for forms, to be reproduced in page format, **35% off.**

#### Copy Deadline for General Gazette

9.30 a.m. Monday - (Private Notices)

9.30 a.m. Tuesday - (Government and Outer Budget Sector Agencies Notices)

### Advertisers should note:

- Late copy received at The Craftsman Press Pty. Ltd. after deadlines will be placed in the following issue of VGG, irrespective of any date/s mentioned in the copy (unless otherwise advised).
- Proofs will be supplied only when requested or at the direction of the Gazette Officer.
- No additions or amendments to material for publications will be accepted by telephone.
- Orders in Council may be lodged prior to receiving assent with the Governor's or Clerk's signature. They will only be published once approved and signed.
- Government and Outer Budget Sector Agencies please note: *See style requirements on back page.*

## SPECIAL GAZETTES

Copy to: Gazette Officer  
The Craftsman Press Pty. Ltd.  
125 Highbury Road,  
Burwood Vic 3125  
Telephone: (03) 9926 1233  
Facsimile: (03) 9926 1292  
Email: [gazette@craftpress.com.au](mailto:gazette@craftpress.com.au)

### Advertising Rates and Payment

#### Private Notices

Full Page \$360.00

Payment must be received in advance with notice details.

#### Government and Outer Budget Sector Agencies Notices

	Typeset
Full Page	\$87.50

#### Note:

The after hours number for Special Gazettes is:

Telephone: 0419 327 321

## SUBSCRIPTIONS AND RETAIL SALES

Copies of the Victoria Government Gazette can be purchased from The Craftsman Press Pty. Ltd. by subscription.

#### The Victoria Government Gazette

General and Special - \$170.00 each year

General, Special and Periodical - \$227.00 each year

Periodical - \$113.00 each year

Subscriptions are payable in advance and accepted for a period of one year. All subscriptions are on a firm basis and refunds will not be given.

**All payments should be made payable to The Craftsman Press Pty. Ltd.**

#### Subscription enquiries:

The Craftsman Press Pty. Ltd.

125 Highbury Road, Burwood Vic 3125

Telephone: (03) 9926 1233

# INDEX TO PRIVATE ADVERTISERS

## A

A.E. Ellinghaus & S.L. Weill .....1550

## B

Basile & Co. ....1550

Beck Sheahan Quinn & Kirkham .....1550

Best Hooper .....1550

## D

Dunhill Madden Butler .....1550

## G

Garden & Green .....1551

G.J. Long & Co. ....1551

Grano & McCarthy .....1551

Gray Friend & Long .....1551

Gray & Gray .....1551

G.R. Herbert & Co. ....1551

## J

John Stewart .....1552

## L

Littleton Hackford .....1552

Lombard & Associates .....1552

## M

Maddock Lonie & Chisholm .....1552

Mahonys .....1552

Mills Oakley .....1552

Mosley & Palmer .....1553

## N

National Australia Trustees Limited ... .1553

National Mutual Trustees Limited ... .1553

Nunan & Bloom .....1553

## P

Perillo, Adami & Frank .....1553

Perpetual Trustees Victoria Limited ... .1554

## R

Roger O'Halloran & Co. ....1554

Russell Kennedy .....1555

## S

Stone Leighton & Davis .....1555

## T

Taylor, Splatt & Partners .....1555

Trust Company of Australia Limited ... .1555

## PRIVATE ADVERTISEMENTS

## A two-day course

# Preparing Reports of Investigations <sup>TM</sup>

Education Design Systems Pty Limited (EDS), a professional and vocational education provider, is offering a two-day course for persons who prepare factual reports of inquiries into alleged or suspected breaches of legislation, procedures or policy. The course is designed for government and non-government investigators, inspectors, compliance officers, mercantile agents, loss assessors, enforcement officials, inquiry agents, police officers, analysts and examiners.

Two courses will be held in Melbourne -

**Dates:** Course 1 - Wednesday 22 and Thursday 23 July 1998 - 9.00am to 4.00pm  
Course 2 - Wednesday 14 and Thursday 15 October 1998 - 9.00am to 4.00pm

**Venue:** Level 2A, 256 Flinders Street, Melbourne

**Cost:** \$590 (includes course handbook, morning and afternoon refreshments and Certificate of Attendance)

This course can be presented in-house, customised to the needs of the organisation.

*For further information or registration please contact: Seminar Secretariat, Conference Co-ordinators - Telephone: 02 6292 9000 - Facsimile: 02 6292 9002 - Email: conference@netinfo.com.au*



## Education Design Systems Pty Limited

Persons who complete EDS courses successfully may be eligible to undertake the external *Graduation Certificate in Investigations* course offered by Charles Sturt University.



Professional and Vocational Education Providers

Sabcurl Pty Ltd, A.C.N. 010 277 335

### NOTICE OF THE FINAL MEETING OF MEMBERS PURSUANT TO SECTION 509 OF THE CORPORATIONS LAW

Notice is hereby given that a Final Meeting of the members of the company be held as follows:

**Place:** Suite 8, 79 High Street, Kew 3101.

**Time:** 09.00 a.m.

**Date:** 31 July 1998.

#### BUSINESS

The purpose of this meeting is to consider the following resolution(s):

1. To receive and adopt the report of the liquidator's act and dealings during the conduct of the winding up.
2. To receive and adopt Australian Securities Commission Form 524 Accounts and Statement by a Liquidator.
3. To transact any other business which

may properly be brought forward at the meeting.

Dated 30 June 1998.

GOETHALS, ABRAHAM JOHN  
Liquidator

#### DISSOLUTION OF PARTNERSHIP

Notice is hereby given pursuant to Section 41 of the **Partnership Act 1958** that Thomas Leslie Williams ceased to be a partner in the partnership of Tarwin View Stud of Masons Road, Lower Tarwin on 30 June 1997. The business will be carried on under the same name by the continuing partner.

HASSALL & BYRNE, solicitors of 308 Highbury Road, Highbury 3190".

#### DISSOLUTION OF PARTNERSHIP

Take note that as from 29 May 1998 the partnership known as I. K. and P. A. Ricardo will cease to operate.

BIRCH ROSS & BARLOW, solicitors, 15 Commercial Street, Korumburra, Vic. 3950.

JUDITH ROSE MARKS, late of 18 Mount View Road, Highett, Victoria, business proprietor, deceased. Creditors, next-of-kin and others having claim in respect of the estate of the deceased, who died on 22 December 1997 are required by the trustees, Robert James Marks and Dee Anne Moore to send particulars to them care of the undermentioned solicitors by 31 August, 1998 after which date the trustees may convey or distribute the assets having regard only to the claims of which they then have notice.

A. E. ELLINGHAUS & S. L. WEILL, solicitors, 129 Drummond Street, Carlton, Victoria 3053.

---

In the estate of ANNIE JEAN CATLEY, late of 30 Carbine Street, Kerang, in the State of Victoria, widow, deceased. Creditors, next-of-kin and all other persons having claims against the estate of the said deceased are required by Alan James Catley, motor mechanic of 146 Victoria Street, Kerang, Victoria and Sylvie Jean Hird, home duties of RSD 1550, Kerang, aforesaid, the executors of the estate of the said deceased, to send particulars of such claims to them in care of the undermentioned solicitors within two months from the date of publication of this notice after which date they will distribute the assets having regard only to the claims of which they then have notice.

BASILE & CO., barristers & solicitors, 46 Wellington Street, Kerang, Victoria 3579.

---

In the estate of RUBY ISOBEL NEWSTEAD of Cohuna District Nursing Home, Cohuna, in the State of Victoria, widow, deceased. Creditors, next-of-kin and all other persons having claims against the estate of the said deceased are required by Peter Henry Newstead of RSD 1506 Milnes Bridge, Kerang, Victoria, farmer, the executor of the estate of the said deceased, to send particulars of such claims to him in care of the undermentioned solicitors on or before the expiration of two (2) months from the date of publication hereof after which date they will distribute the assets having regard only to the claims to which they then have notice.

BASILE & CO., barristers & solicitors, 46 Wellington Street, Kerang, Victoria 3579.

---

Creditors, next-of-kin or others having claims in respect of the estate of SYDNEY RICHARD ARTHUR MOORE, late of 18 Osborne Avenue, Kangaroo Flat, Victoria, farmer, deceased, who died on 9 April 1998 are to send particulars of their claims to the executor, care of the undermentioned solicitors by 17 August 1998 after which date the executor will distribute the assets having regard only to the claims of which the executor then has notice.

BECK SHEAHAN QUINN & KIRKHAM, solicitors, 110 Pall Mall, Bendigo.

---

JOHN HODGSON ROUNTREE, late of 15 Chatham Road, Canterbury. Creditors, next-of-kin and others having claims in respect of the estate of the deceased who died on 7 September 1997 are required by Perpetual Trustees Victoria Limited, A.C.N. 004 027 258 of 50 Queen Street, Melbourne, to send particulars of their claims to the said company by 14 August 1998 after which date it will convey or distribute the assets having regard only to the claims of which the company then has notice.

BEST HOOPER, solicitors, 563 Little Lonsdale Street, Melbourne.

---

THEA ROUNTREE, late of 15 Chatham Road, Canterbury. Creditors, next-of-kin and others having claims in respect of the estate of the deceased who died on 24 September 1997 are required by Perpetual Trustees Victoria Limited, A.C.N. 004 027 258 of 50 Queen Street, Melbourne, to send particulars of their claims to the said company by 14 August 1998 after which date it will convey or distribute the assets having regard only to the claims of which the company then has notice.

BEST HOOPER, solicitors, 563 Little Lonsdale Street, Melbourne.

---

Creditors, next-of-kin or others having claims in respect of the estate of RUBY MAY AITKEN, late of 2 Pascoe Avenue, Springvale, Victoria, home duties, deceased, who died on 20 August 1997 are to send particulars of their claims to the executors, Barbara Ann Green of 375 Old Drouin Road, Longwarry, Victoria and Deanne Louise Aitken of Unit 2, 18 Magnolia Road, Gardenvale, Victoria by 9 September 1998 after which date the executors will distribute the assets having regard only to the claims of which the executors then have notice.

DUNHILL MADDEN BUTLER, solicitors, 575 Bourke Street, Melbourne.

---

Creditors, next-of-kin or others having claims in respect of the estate of EILEEN JANE HARVEY, late of Alcheringa Hostel, Rutherford Street, Swan Hill, Victoria, home duties, deceased, who died on 24 April 1998 are to send particulars of their claims to the executor, Leonard Oliver Harvey, care of the undermentioned solicitors by 19 August 1998 after which date the executor will distribute the assets having regard only to the claims of which he then has notice.

GARDEN & GREEN, lawyers, 4 McCallum Street, Swan Hill.

---

ADELAIDE CAROLINE DUGAN, late of Nursing Home, Corryong District Hospital, Kiel Street, Corryong, Victoria, widow, deceased. Creditors, next-of-kin and others having claims in respect of the estate of the deceased, who died on 22 February 1998 are required by the executors, Andrew Alston Albert of "Colac Colac", Corryong, Victoria, agent, and Gregory James Long of "The Kurrajongs", Mt Alfred, Victoria, solicitor, to send particulars to them in care of G. J. Long & Co., solicitors, P.O. Box 7, Corryong 3707 by 15 September 1998 after which date the executors may convey or distribute the assets having regard only to the claims of which they then have notice.

G. J. LONG & CO., solicitors, P.O. Box 7, Corryong, 3707.

---

ALAN MALCOLM MARSHALL, late of 131 Napier Street, Stawell, farmer, deceased. Creditors, next-of-kin and others having claims in respect of the estate of the deceased who died on 21 August 1997 are required by Basil John Thurloway Marshall and Mary Jean Marshall, the administrators of the estate of the deceased, to send particulars of their claims to them care of the undermentioned solicitors by 31 August 1998 after which date they will convey or distribute the assets having regard only to the claims of which they then have notice.

GRANO & McCARTHY, solicitors, 178 Barkly Street, Ararat 3377.

---

JOAN BORTHWICK McGHIE McCLURE LACEY, formerly of 1 Acacia Street, Drouin, but late of 133 Normanby Street, Warragul, widow, deceased. Creditors, next-of-kin and

others having claims in respect of the estate of the deceased, who died on 14 January 1998 are required by the trustees, Lindsay James Muirhead, Ian Richard Brooks and Dennis Richard Heslin, to send particulars of their claims to them care of the undersigned solicitors by 25 August 1998 after which date the trustees may convey or distribute the assets having regard only to the claims of which they then have notice.

GRAY FRIEND & LONG, solicitors, 70 Queen Street, Warragul 3820.

---

MARION ETHEL MORGAN, formerly of Allen Road, Lardner, but late of Lyrebird Village Hostel, Neerim Street, Drouin, widow, deceased. Creditors, next-of-kin and others having claims in respect of the estate of the deceased, who died on 28 January 1998 are required by the trustees, John Charles Morgan, Stuart McKenzie Morgan and Christine Margaret Morgan, to send particulars of their claims to them care of the undersigned solicitors by 26 August 1998 after which date the trustees may convey or distribute the assets having regard only to the claims of which they then have notice.

GRAY FRIEND & LONG, solicitors, 70 Queen Street, Warragul 3820.

---

Creditors, next-of-kin and others having claims in respect of the estate of GEORGE TERPKOU, late of 39 Henry Street, Northcote, Victoria, retired, who died on 10 June 1995 are to send particulars of their claims to the executor, Theodore Terpkou, care of the undermentioned solicitors by 28 August 1998 after which date the executor will distribute the assets having regard only to the claims of which he then has notice.

GRAY & GRAY, solicitors, 188 High Street, Northcote.

---

Creditors, next-of-kin or others having claims in respect of the estate of PAMELA BETH JORGENSEN, late of 11 Vardon Avenue, Beaumaris, married woman, deceased who died on 13 January 1998 are to send particulars of their claims to the executor care of the undermentioned solicitors by 28 August, 1998 after which date the executor will distribute the assets having regard only to the claims of which he then has notice.

G. R. HERBERT & CO., legal practitioners, 8 Bluff Road, Black Rock 3193.

---

Creditors, next-of-kin and others having claims in respect of the will of FRANCIS XAVIER HESS, late of Nazareth House, 16 Cornell Street, Camberwell, Victoria, retired, deceased, who died on 23 April 1998 are requested to send particulars of their claims to the executors, Mary Elizabeth Hess and Bernadette Cecilia Hess, care of the undermentioned legal practitioner by 26 August, 1998 after which date they will distribute the assets having regard only as to the claims of which they then have notice.

JOHN STEWART, legal practitioner, 290 Racecourse Road, Newmarket.

---

Creditors, next-of-kin and others having claims in respect of the will of GERALD MICHAEL MOONEY, late of 28 May Street, Essendon, Victoria, retired, deceased, who died on 18 May 1998 are requested to send particulars of their claims to the executor, Peter Michael Mooney, care of the undermentioned legal practitioner by 26 August, 1998 after which date he will distribute the assets having regard only as to the claims of which he then has notice.

JOHN STEWART, legal practitioner, 290 Racecourse Road, Newmarket.

---

Creditors, next-of-kin and others having claims in respect of the estate of SARAH ELIZABETH ARMER, late of 7 Brooks Street, Traralgon, Victoria, widow, deceased, who died on 22 May 1998 are to send particulars of their claims to the executors, Thomas Leslie Armer of 11 Shaw Street, Ashwood, Victoria and Maureen Denise Wood of 24 Lawley Crescent, Pymble, New South Wales, care of the belowmentioned solicitors by 24 August 1998 after which date they will distribute the assets of the deceased having regard only to the claims of which they then have notice.

LITTLETON HACKFORD, solicitors, "Law Chambers", 115 Hotham Street, Traralgon, Vic. 3844.

---

Creditors, next-of-kin and others having claims in respect of the estate of EVELEEN MARY VASSETT, deceased, who died on 1 April 1998 are required by the executrix to send particulars of their claim to the undermentioned firm by 21 August 1998, after

which date the trustee will convey or distribute the assets having regard only to the claims of which the trustee then has notice.

LOMBARD & ASSOCIATES, solicitors, 27 Station Road, Cheltenham.

---

Creditors, next-of-kin or others having claims in respect of the estate of HAINSWORTH THOMAS COCK, late of 11 Benson Drive, Coldstream, Victoria, retired, deceased, who died on 19 December 1997 are to send particulars of their claims to the executors care of the undermentioned solicitors by 25 August 1998 after which date the executors will distribute the assets having regard only to the claims of which the executors then have notice.

MADDOCK LONIE & CHISHOLM, solicitors, 140 William Street, Melbourne.

---

Creditors, next-of-kin and all other persons having claims against the estate of DOROTHEA McFARLANE, late of 459 Wattletree Road, East Malvern, in the State of Victoria, deceased, who died on 13 May 1998 are to send particulars of their claims to the executor of the estate, care of the undermentioned solicitors by 27 August, 1998 after which date the executor will convey and distribute the assets having regard only to the claims of which the executor then has notice.

MAHONYS, solicitors, 400 Collins Street, Melbourne, Victoria 3000.

---

Creditors, next-of-kin and others having claims in respect of the estate of KEITH CORBY, late of 387 Kooyong Road, Elsternwick, Victoria, retired, deceased, (who died on 19 February 1998) are required by the executor, ANZ Executors & Trustee Company Limited of 530 Collins Street, Melbourne, Victoria, to send particulars to it by 25 August 1998 after which date it may convey or distribute the estate having regard only to the claims of which it then has notice.

MILLS OAKLEY, lawyers, 131 Queen Street, Melbourne.

---

Creditors, next-of-kin and others having claims in respect of the estate of CATHERINE ALICE MATHESON, late of 4 Berry Court, Highton, Victoria, married woman, deceased,

who died on 29 March 1998 are required by the executor, ANZ Executors & Trustee Company Limited of 530 Collins Street, Melbourne, Victoria, to send particulars to it by 25 August 1998 after which date it may convey or distribute the estate having regard only to the claims of which it then has notice.

MILLS OAKLEY, lawyers, 131 Queen Street, Melbourne.

---

THOMAS EDLINGTON ROBINSON, late of 69 Stanley Street, Orbost, Victoria, farmer. Creditors, next-of-kin and others having claims in respect of the estate of the deceased who died on 16 April 1998 are required by the trustee, James Thomas Robinson of Watt Road, Orbost, Victoria, farmer, to send particulars to his solicitors within sixty days from the date of publication of this notice after which date the trustee may convey or distribute the assets having regard only to the claims of which they then have notice.

MOSLEY & PALMER, solicitors, P.O. Box 243, Orbost 3888.

---

JOAN ELLEN GOWLAND, late of Marivale Nursing Home, 69-73 Epsom Road, Ascot Vale, widow, deceased. Creditors, next-of-kin and others having claims in respect of the estate of the deceased, who died on 1 March 1998 are required by National Australia Trustees Limited, (A.C.N. 007 350 405) of 271 Collins Street, Melbourne to send particulars of their claims to the said company by 25 August 1998 after which date it will convey or distribute the assets having regard only to the claims of which the company then has notice.

---

Creditors, next-of-kin and others having claims in respect of the estate of ALFRED FRANCIS TRUSCOTT MILES, late of Emu Creek, Victoria, farmer, deceased, who died on 20 November 1997 are required to send particulars of their claims to the executors, National Mutual Trustees Limited of 46 Queen Street, Bendigo, by 31 August, 1998 after which date they will distribute the assets having regard only to the claims of which they have notice.

NATIONAL MUTUAL TRUSTEES LIMITED, 46 Queen Street, Bendigo.

---

Creditors, next-of-kin and others having claims in respect of the estate of CARL SCHLEIGER (in the Will called Charles Schleiger), late of 4 Edward Court, Kangaroo Flat, Victoria, pensioner, deceased, who died on 28 December 1997 are required to send particulars of their claims to the executors, National Mutual Trustees Limited of 46 Queen Street, Bendigo by 27 August, 1998 after which date they will distribute the assets having regard only to the claims of which they then have notice.

NATIONAL MUTUAL TRUSTEES LIMITED, 46 Queen Street, Bendigo.

---

Creditors, next-of-kin and others having claims in respect of the estate of CARMEL MARY MULLIGAN, late of Claremont Home, 288 Albert Road, South Melbourne, in the State of Victoria, gentlewoman, deceased, who died on 4 February 1998 are required to send particulars of such claims to National Mutual Trustees Limited of 65 Southbank Boulevard, Southbank, by 26 August 1998, the said company having been authorised by the executors, John Patrick Mulligan and Patricia Mary Gilchrist, after which date the company will distribute the estate having regard only to the claims of which they then have notice.

---

MARY VERONICA GROGAN, formerly of 10 Susan Street, Dromana, in the State of Victoria, but late of 34A Balaka Street, Rosebud West, Victoria, deceased. Creditors, next-of-kin and others having claims in respect of the estate of the deceased, who died on 26 March 1998 are required by Ronald Milton Grogan, the executor, to send particulars to him care of the undermentioned solicitors by 28 August 1998 after which date the said Ronald Milton Grogan may convey or distribute the assets having regard only to the claims of which he then has notice.

NUNAN & BLOOM, solicitors, Level 8, 343 Little Collins Street, Melbourne 3000.

---

Creditors, next-of-kin or others having claims in respect of the estate of OTTAVIO MAURO, late of 8 Pearson Street, Brighton in the State of Victoria, retired, deceased, who died on 20 October 1995 are to send particulars of their claims to the executor care of the undermentioned solicitors by 25 August, 1998

after which date the executor will distribute the assets having regard only to the claims of which the executor then has notice.

PERILLO, ADAMI & FRANK, solicitors, 209 Nicholson Street, Footscray.

---

JOHN KESHAN MAXWELL CARROLL, late of Kingston Centre, Warrigal Road, Cheltenham, Victoria 3192. Creditors, next-of-kin and others having claims in respect of the deceased, who died on 1 May 1998 are required by Perpetual Trustees Victoria Limited, A.C.N. 004 027 258, of 50 Queen Street, Melbourne, to send particulars of their claims to the said company by 25 August 1998 after which date it will convey or distribute the assets having regard only to the claims of which the company then has notice.

---

EILEEN JEAN McTAGGART, late of the Andrew Kerr Hostel of 67-69 Tanti Avenue, Mornington, Victoria 3931. Creditors, next-of-kin and others having claims in respect of the deceased, who died on 22 April 1998 are required by Perpetual Trustees Victoria Limited, A.C.N. 004 027 258, of 50 Queen Street, Melbourne, to send particulars of their claims to the said company by 25 August 1998 after which date it will convey or distribute the assets having regard only to the claims of which the company then has notice.

---

ARTHUR JOSEPH PLUMRIDGE, late of 3/30 Barkly Street, Box Hill, deceased. Creditors, next-of-kin and others having claims in respect of the deceased, who died on 13 April 1998 are required by Perpetual Trustees Victoria Limited, A.C.N. 004 027 258, of 50 Queen Street, Melbourne, to send particulars of their claims to the said company by 26 August 1998 after which date it will convey or distribute the assets having regard only to the claims of which the company then has notice.

---

BERYL EDITH GERTRUDE RILEY, late of Room 209, Salford Park, 100 Harold Street, Wantirna, deceased. Creditors, next-of-kin and others having claims in respect of the deceased, who died on 24 April 1998 are required by Perpetual Trustees Victoria Limited, A.C.N. 004 027 258, of 50 Queen Street, Melbourne, to send

particulars of their claims to the said company by 26 August 1998 after which date it will convey or distribute the assets having regard only to the claims of which the company then has notice.

---

ELIZABETH FRANCES GWENDOLYNE WHITE, late of Jharmbi Nursing Home, Inala Village, 220 Middleborough Road, Blackburn South, deceased. Creditors, next-of-kin and others having claims in respect of the estate of the deceased, who died on 16 May 1998 are required by Perpetual Trustees Victoria Limited, A.C.N. 004 027 258, of 50 Queen Street, Melbourne, to send particulars of their claims to the said company by 26 August 1998 after which date it will convey or distribute the assets having regard only to the claims of which the company then has notice.

---

BEATRICE INA ZERCHO, late of Broadmead Hostel, 27 Wattle Road, Hawthorn, deceased. Creditors, next-of-kin and others having claims in respect of the deceased, who died on 16 May 1998 are required by Perpetual Trustees Victoria Limited, A.C.N. 004 027 258, of 50 Queen Street, Melbourne, to send particulars of their claims to the said company by 26 August 1998 after which date it will convey or distribute the assets having regard only to the claims of which the company then has notice.

---

Estate of JAMES HENRY O'TOOLE, late of 31 Torquay Road, Belmont, Victoria, retired, deceased. Creditors, next-of-kin and others having claims in respect of the estate of the deceased, who died on 29 March 1998 are required by Raymond Stanley Cooper of 27 Watsons Road, Newcomb, Victoria, Shirley Margaret Dew of 9 Wirth Court, Newcomb, Victoria and Roger O'Halloran of 30 Mount Pleasant Road, Belmont, Victoria, the executors to whom probate was granted, to send particulars to them by 25 August 1998 after which date the executors may convey or distribute the assets having regard only to the claims of which they then have notice.

ROGER O'HALLORAN & CO., solicitors, 63 Gheringhap Street, Geelong.

---

Estate of GORDON ALEXANDER STEPHENS, late of Unit 127 Greenwood Manor, 52-70 Centre Dandenong Road,



Dingley, Victoria, retired, deceased. Creditors, next-of-kin and others having claims in respect of the estate of the deceased, who died on 23 June 1997 are required by Brenda Susan Griffin of 7 Cavendish Drive, Heatherton, Victoria, the executrix to whom probate was granted to send particulars to her by 25 August 1998 after which date the executrix may convey or distribute the assets having regard only to the claims of which she then has notice.

ROGER O'HALLORAN & CO., solicitors, 63 Gheringhap Street, Geelong.

---

Estate of EILEEN NORAH WILLIAMSON, late of 27 Toolambool Road, Carnegie, deceased. Creditors, next-of-kin and others having claims in respect of the estate of the deceased, who died on 14 September 1996, are required by Neil John Cook, the executor of the Will of the deceased, to send particulars of their claims to the executor in the care of the undermentioned solicitors by 1 September 1998 after which date the executor may convey or distribute the assets having regard only to the claims of which the executor then has notice.

RUSSELL KENNEDY, solicitors, 11th Floor, 469 La Trobe Street, Melbourne.

---

Creditors, next-of-kin or others having claims in respect of the estate of DOROTHY MAY NELSON, late of 20 Sutton Parade, Box Hill North, 3129, widow, deceased, who died on 10 June 1998 are to send particulars of their claims to the executor care of the undermentioned solicitors by 14 September 1998 after which date the executor will distribute the assets having regard only to the claims of which the executor then has notice.

STONE LEIGHTON & DAVIS, solicitors, 221 High Street, Kew.

---

Creditors, next-of-kin or others having claims in respect of the estate of FLORENCE EVA PITCHER, late of "Alexandra", 304 Hawthorn Road, Caulfield South, home duties, deceased, who died on 13 April 1998 are to send particulars of their claims to the executor care of the undermentioned solicitors by 14 September 1998 after which date the executor will distribute the assets having regard only to the claims of which the executor then has notice.

STONE LEIGHTON & DAVIS, solicitors, 221 High Street, Kew.

---

Creditors, next-of-kin and others having claims in respect of the estate of GEORGE EDWARD CLARENCE GOMM, late of 296 Jones Road, Somerville in the State of Victoria, pensioner, deceased, who died on 14 February 1998 are to send particulars of their claims to the executor, care of the undermentioned solicitors by 25 August 1998 after which date the executor will distribute the assets having regard only to the claims of which he then has notice.

TAYLOR, SPLATT & PARTNERS, solicitors, P.O. Box 148, Frankston, Victoria 3199. Telephone (03) 9787 7700.

---

EDNA ANGWIN formerly of 5 Lebanon Avenue, Glenunga, in the State of South Australia but lately of Strabane Gardens, 1-3 Strabane Avenue, Box Hill North, Victoria, deceased. Creditors, next-of-kin and others having claims in respect of the estate of the deceased who died on 17 April 1998 are required by Trust Company of Australia Limited of 151 Rathdowne Street, Carlton South, one of the executors, to send particulars to it by 27 August 1998 after which date Trust Company of Australia Limited may convey or distribute the assets having regard only to the claims of which it then has notice.

---

In the County Court of the State of Victoria  
SALE BY THE SHERIFF

On 30 July 1998 at 2.30 p.m. at the Sheriff's Office, 8-20 King Street, Oakleigh (unless process be stayed or satisfied).

All the estate and interest (if any) of Nikolay Solodchenko of 11 Morwell Street, Dandenong as shown on Certificate as Nickolky Solodchenko, proprietor of an estate in fee simple in all that piece of land being Lots 72 and 73 on Plan of Subdivision No. 6672 and being the whole of the land described in Certificates of Title Volume 7967 Folio 086 and Volume 8634 Folio 068 upon which is erected a small shingle clad dwelling with Cyclone Boundary Fencing.

The property can be located by travelling to Crib Point. At the Shell Garage turn east into Disney Street and then north into Glossop Street, then east into Creswell Street, which is a gravel road. The property is at the end of Creswell Street and is known as Lots 72 and 73 Creswell Street, Crib Point.

The drainage easement reserved by Transfer 841256 affects part of the within land.

Terms - Cash only.

CW-98-001992-0.

Dated 25 June, 1998.

S. BLOXIDGE  
Sheriff's Office

In the County Court of the State of Victoria

SALE BY THE SHERIFF

To the Highest Bidder at the Best Price Offered

On 30 July 1998 at 2.30 p.m. at the Sheriff's Office, 8-20 King Street, Oakleigh (unless process be stayed or satisfied).

All the estate and interest (if any) of Sydney George Zammit of 21 McComb Boulevard, Frankston as shown on Certificate of Title as Sydney Zammit, proprietor of an estate in fee simple in the land described on Certificate of Title Volume 8330 Folio 737 upon which is erected a house known as 21 McComb Boulevard, Frankston.

Registered Caveat Nos. T596058E and T961968W affect the said estate and interest

No reserve set.

Terms - Cash only.

CW-98-006208-1.

Dated 25 June, 1998.

S. BLOXIDGE  
Sheriff's Office

In the Supreme Court of the State of Victoria

SALE BY THE SHERIFF

On 31 July 1998 at 11.00 a.m. at the Sheriff's Office, Corner Fenwick & Little Malop Streets, Geelong (unless process be stayed or satisfied).

All the estate and interest (if any) of Tom Wallis of 91 Ormond Road, East Geelong as shown on Certificate of Title as Thomas William Wallis, proprietor of an estate in fee simple in the land described on Certificate of Title Volume 4550 Folio 864 upon which is erected a Shop/Dwelling known as 91 Ormond Road, East Geelong.

Registered Mortgage No. U353914T affects

the said estate and interest.

Terms - Cash only.

SW-98-003393-9.

Dated 25 June, 1998.

S. BLOXIDGE  
Sheriff's Office

In the Supreme Court of the State of Victoria

SALE BY THE SHERIFF

On 23 July 1998 at 2.30 p.m. at the Sheriff's Office, 8-20 King Street, Oakleigh, 3166 (unless process be stayed or satisfied).

All the estate and interest (if any) of Jennifer Ellen Daish of 3 Teal Court, Narre Warren, joint proprietor with Grant Andrew Daish (now Bankrupt) of an estate in fee simple in the land described on Certificate of Title Volume 10116 Folio 399 upon which is erected a dwelling known as 3 Teal Court, Narre Warren.

Registered Mortgage Nos. S976002L, U389132X, Caveat Nos. U618803D, V68888G and Covenant No. S976001P affect the said estate and interest.

Terms - Cash only.

SW-97-015478-6.

Dated 18 June, 1998.

S. BLOXIDGE  
Sheriff's Office

**Unclaimed Moneys Act 1962**

Register of Unclaimed Moneys held by the —

<i>Name of Owner on Books and Last Known Address</i>	<i>Total Amount Due to Owner</i>	<i>Description Of Unclaimed Money</i>	<i>Date when Amount first became Payable</i>
TGI AUSTRALIA LIMITED — VICTORIA			
\$			
Talk Finance (Aust.) Pty Ltd, 127 Erskine St, Middle Park	128.73	Cheque	07.03.95
E. R. Yarram, 148 Fitzroy Street, Fitzroy	150.00	"	05.08.95
Mr M. & Mrs T. Fallace, 11 Burke Road, South Oakleigh	650.00	"	17.06.96
Eris Censori, 85 Sprint Street, Melbourne	422.87	"	13.11.95
Maurice Blackburn & Co, 422 Collins Street, Melbourne	1,093.80	"	29.11.95
Nhan Van Le, 72 Virginia Street, Springvale	350.00	"	23.11.95
Coffey Ford, TGI Australia	356.00	"	05.12.95
Yuncken & Yuncken, 395 Collins Street, Melbourne	133.20	"	15.12.95
Mr S. S. Moce, 2/5 Regent Avenue, Springvale	450.00	"	13.02.96
Hoang Pham, 27 Burnett Avenue, Braybrook	1,669.00	"	16.02.96
Victorian Police, P.O. Box 415, World Trading, Melbourne	130.00	"	23.02.96
Y. Zhou, P.O. Box 192 Ormond	184.72	"	29.02.96
Metropolitan Fire Brigades, P.O. Box 151, East Melbourne	3,468.21	"	27.03.96
AGC Finance Ltd, 277 William Street, Melbourne	205.95	"	16.04.96
B. T. Shadinuofu, Noble Park	400.00	"	16.08.96

98062

CONTACT: AMP GENERAL INSURANCE, PHONE: (02) 9257 5000.

**Unclaimed Moneys Act 1962**

Register of Unclaimed Moneys held by the —

<i>Name of Owner on Books and Last Known Address</i>	<i>Total Amount Due to Owner</i>	<i>Description Of Unclaimed Money</i>	<i>Date when Amount first became Payable</i>
AMP GENERAL INSURANCE			
\$			
Mr A. M. Kattan, 2 Koscuisko Court, Lalor	100.00	Cheque	14.10.94
P. J. Welsh, P.O. Box 33, Rosebud	103.86	"	17.02.95
Estate of Z. Kowalinski, 24 Rostella Crescent, East Keilor	104.19	"	09.08.96
E. Lo, 287 Emerald Street, Preston	104.89	"	30.06.95
John Andrew Sullivan, 17 Crown Street, Glen Waverley	105.63	"	17.05.96
D. J. Collyer, 35 Spenser Street, St Kilda	105.84	"	02.11.94
S. & M. Midgley, 1 Rd Yangminshan Tynan Roc	107.80	"	16.11.94
Don & Bradstreet, P.O. Box 7405 St Kilda Rd, Melbourne	110.00	"	06.03.96

For the Estate of M. Fueggle, 59 Beard Street, Eltham	110.75	''	28.09.95
Pierre's Photographic Ctr, 13 Station Street, Werribee	112.05	''	03.11.94
M. P. Watts, 2/12 Harnett Drive, Seaford	117.22	''	11.01.95
J. C. Turner, 5 Shields Street, Flemington	118.38	''	19.02.96
L. E. Cartan RMB, 505 Beremboke	118.38	''	31.10.95
Mc Dermott Building Services, 264 Keilor Rd, North Essendon	120.00	''	16.02.96
G. & G. Ferguson, 37 Cameron Avenue, Shepparton	122.00	''	23.11.94
J. Stanton, 3/14 Turner Road, Highett	125.16	''	03.05.95
E. & J. Liu, C/-C. David, 16th Floor (General) 535 Bourke Street, Melbourne	132.61	''	16.10.96
M. & D. Jones, 555 Main Street, Mordialloc	139.00	''	30.01.95
J. R. Morrison, 121 William Street, Melbourne	142.16	''	14.02.96
Body Corporate, Plan No, 761 6/20 Yuille Street, Brighton	148.90	''	22.07.96
Credit Investigators, 4/10 Ashted Road, Box Hill	150.00	''	26.09.97
M. & F. Toppi Plumbi, 1/23 Foster Avenue, Glenhuntly	150.00	''	19.07.95
Mr G. M. Zahra, 16 Amstel Street, Craigieburn	150.00	''	08.03.95
T. Marangioudis, Acland Street, St. Kilda	150.79	''	01.06.95
Matt Wynne Designer Jeweller, 9 Law Street, Sth Melbourne	153.00	''	16.10.96
V. D. Pivioni, C/-77 Kedron Brook Road, Wilston	153.20	''	02.11.95
Major Entertainment, C/-Area Manager, P.O. Box 117, Upper Ferntree Gully	154.56	''	19.06.96
Beaumaris Print's and Framing, 17 Hilton Street, Beaumaris	154.82	''	01.11.96
J. R. Room, 280 St Kilda Road, Melbourne	155.00	''	20.09.96
O'Brien Glass, 2 Princess Street, Port Melbourne	157.00	''	11.11.96
C. & L. Busuttil, 25 Tamboon Drive, Rowville	160.54	''	26.08.96
Cover More Travel Insurance, 575 Bourke Street, Melbourne	162.00	''	30.06.95
Cover More Travel Insurance, 575 Bourke Street, Melbourne	162.00	''	''
Ron Harrison's Motor Body, 116 Mitchell Street, Maidstone	170.55	''	05.02.96
O, M., Fisher, 59 Victoria Street, Kerang	172.50	''	07.07.95
K. V. Ball P/L, T/AS Plastics, 1 Harker Street, Burwood	174.61	''	22.02.96
Mr I. J. Clenaghan, 235 Gallaghers Road, Glen Waverley	179.00	''	15.08.96
Global Communications, 121 William Street, Melbourne	180.00	''	21.12.95
M. & H. J. Debnam, 68 Princes Highway, Hallam	180.00	''	04.12.95
M. McKenzie, 121 William Street, Melbourne	187.50	''	17.11.94
State Trustees, 13 Palmer Street, Oakleigh	192.00	''	01.01.95
T. Antoniou, 167 High Street, Berwick	193.40	''	06.03.96
L. Allen, 555 Main Street, Mordialloc	196.20	''	30.01.95
A. R. & A. Allan, 10 Boronia Crescent, Traralgon	198.00	''	22.01.96
S. K. Ho & J. Wai, 55 Sandgate Avenue, Glen Waverley	199.58	''	06.07.95
E. M. Smowak, C/-M Glynn, Cnr View Street & McKenzie Road, Bendigo	199.60	''	18.10.95
Mr K. Perdikis, 12/31-33 First Street, Clayton South	203.20	''	12.12.95
Perlow Towing Service, P.O. Box 158, Fitzroy	205.00	''	01.12.94
T. S. & T. S. Nguyen, 183 Eley Road, Blackburn South	205.00	''	01.01.96
A. J. Galea & J. Bryant, 264 Keilor Rd, North Essendon	218.50	''	16.02.96
N. & R. Plumbing, 20 Lynwood Crescent, Lower Plenty	220.00	''	10.01.96
Strata Title No. PS317628K 1/23 Foster Avenue, Glenhuntly	230.00	''	23.05.95
Van C. Ho, 10 Fitzroy Street, Footscray	245.80	''	21.11.94
IBM Repair Centre, 207-209, Normanby Rd, Sth Melbourne	248.00	''	01.08.96
Papa Leos Take/Bake Pizza P/L, 171 Centre Rd, Bentleigh	250.00	''	16.08.95
S. Hoare, P.O. Box 219D, Melbourne	250.00	''	14.06.95
Mr H. D. Rumble, 20 Sharrock Drive, Dingley	255.62	''	25.05.95
Century Four Cinemas, High Street, Cranbourne	257.41	''	27.12.95

RACV Insurance, 422 Little Collins Street, Melbourne	263.58	''	23.06.95
Ung Hwan Kim T/As Strathfield Plaza Shoe Repair 11 The Boulevard, Strathfield	276.61	''	11.03.97
W. R. Ajani, 65 Sranhope Road, Rushworth	280.00	''	28.08.96
Trizarra Ten Pty Ltd, 16 Raftery Road, Shepparton	281.50	''	21.11.95
V. K. Tran, Shop 2, Burwood Shop Centre	286.80	''	21.02.95
G. Rees, 43 Ross Street, Tatura	300.00	''	04.07.95
Major Furnace and Engineering, P.O. Box 990, Geelong	300.00	''	12.04.95
Middleton, Moore & Bevins, G.P.O. Box 4388Q	300.00	''	06.09.95
W. Bremner & Sons, O.O. Box 83, Caulfield East	320.00	''	02.03.95
Cafe on Patterson, 43 Patterson Road, Patterson	322.60	''	04.11.94
Peter Hawkins, 200 Commercial Road, Heyfield	325.00	''	16.05.96
Gippsland Claim Assessors, P.O. Box 423, Morwell	329.00	''	11.03.96
Smith ???, 1721 Malvern Road, Glen Iris	330.00	''	15.11.95
GSA Group, 71 Queens Road, Melbourne	330.36	''	19.01.95
P. & A. Grant	339.70	''	03.03.95
O'Brien Glass Industries, 2-4 Princes St, Port Melbourne	344.00	''	01.11.96
C. Hayes & H. Louey, 116 Bridport Street, Albert Park	344.12	''	23.05.95
Macmillan, Segal & Lenton, P.O. Box 344, Sth Melbourne	350.00	''	11.07.95
O'Farrell Security Shuttering, 57 Frederick St, Caulfield	350.00	''	17.10.96
Mr D. Pepicelli, Melbourne Street, Sales Centre	352.72	''	03.04.95
Mr Rogers, 20 Prospect Street, Box Hill	377.72	''	28.12.94
Immediate Assessing, P.O. Box 83, East Ringwood	387.73	''	30.05.95
Mr John Bowman, P.O. Box 14099, Melbourne	400.00	''	06.11.96
RACV Insurance, 422 Little Collins Street, Melbourne	400.00	''	09.02.96
RACV Insurance, 422 Little Collins Street, Melbourne	400.00	''	21.06.95
RACV Insurance, 422 Little Collins Street, Melbourne	400.00	''	22.03.97
Body Corporate Strata 17529, 40 Gladstone St, Warragull	401.73	''	03.07.95
I. A. Iayers, 19 Yarra Grove, Hawthorn	403.33	''	22.11.95
Kevin A. Fanner P/L, AMP Society, Balwyn	423.56	''	26.07.95
C. Stocklot, 124 Campbellwell Road, Hawthorn	426.00	''	23.01.95
D. W. Rogers, 1st Floor, 121 William Street, Melbourne	426.00	''	17.09.96
Dept. of Health & Community, Lvl 6/555 Collins St, Melbourne	450.00	''	01.03.96
Department of Premier & Cabinet, 10th Floor, 55 Collins St, Melbourne	450.00	''	28.03.95
Glacier Holdings (Aust.) P/L, P.O. Box 267, Ferntree Gully	500.00	''	10.04.95
Browns TV Service, 43 Ross Street, Tatura	518.10	''	04.07.95
Sunraysia Crash Repairs, 101 Homestead Court, Mildura	532.10	''	28.07.95
Industrial Hy-Tech Constion, 9 Willis Street, Teesdale	550.00	''	13.11.96
Vanderwiel Motors P/L, 189 Waverley Road, Waverley	578.89	''	12.02.96
Mr D. Appleby, C/-M. Mangiafico, Ext. 26126	581.10	''	10.11.94
Iconville MDS, 12 Marine St Kilda	595.00	''	08.05.96
Kreepy Krauly, Unit 18/11 Havelock Road, Bayswater	600.00	''	07.02.96
Silmar Investments, 31 Logan Street, Glenroy	600.00	''	17.05.96
Oreilly MX, 124 Camberwell Road, Hawthorn	612.70	''	21.11.94
Mr M. E. Mundy, 34 Hamilton Street, Orbost	617.14	''	18.09.96
D. Jones, 6/29 Broadway, Bon Beach	650.00	''	27.03.95
Mohammed Atiyeh, P.O. Box 192, Ormond	650.00	''	06.10.95
International Specialists Underwriters Ltd	675.00	''	22.12.94
P. E. Wilson, 387 St Kilda Road, Melbourne	700.00	''	25.01.95
Steeves Lumley Ltd, 499 St Kilda Road, Melbourne	725.47	''	11.07.95
Bike House, 447 Centre Road, Berwick	791.00	''	08.05.95
J. & P. & H. Gazeas, 124 Campbell Road, Hawthorn	799.34	''	06.02.95

Triamp Financial Services C/-Intl Mail Triamp, Vic. Queen Victoria Jewellers, Queen Victoria Market "F" Shed, Shop 10, Melbourne	823.11	"	02.08.95
W. B. Webb, 150 Waterfull Gully Road, Rosebud South	850.00	"	02.02.96
O.P.S.M., 1 1 3000	850.00	"	25.01.95
Middletons, Moore & Bevins, G.P.O. Box 4388 QQ, Melbourne	855.00	"	16.08.96
Sunshine Truck & Body Repairs, 34 Evans Street, Braybrook	965.60	"	08.11.95
RACV Insurance Pty Ltd, 422 Little Collins St, Melbourne	1,022.33	"	08.05.95
Sun Alliance & Royal Insurance, Box 294, Market Street, Melbourne	1,074.07	"	17.04.96
Victoria Police	1,135.00	"	22.06.95
Eric & Andrew Jaksch, Lot 14, Kalino View Estate, Balwyn	1,230.00	"	18.01.95
Trapnells P/L, Menzies Avenue, Brighton	1,240.00	"	03.07.96
Grace Costs Consultants, 600 Bourke Street, Melbourne	1,245.00	"	24.04.96
Zycon Pty Ltd, 20 Prospect Street, Box Hill	1,303.00	"	09.08.96
Sun Alliance & Royal Insurance DX 405, Melbourne	1,308.60	"	21.11.94
Hannan & Co., 71 Queens Road, Melbourne	1,500.00	"	13.08.96
Smyths Jewellers, 79 Browning Street, Portland	1,575.00	"	02.12.94
Hannan & Co. Pty Ltd, Melbourne	1,700.00	"	12.11.96
Highland Premium Funding, P.O. Box 7229, St Kilda	1,749.06	"	06.01.95
N. Peavey . . . 3000	2,126.16	"	12.09.96
Arnold Thomas & Becker, P.O. Box 14099, Melbourne	2,082.00	"	05.07.96
Steeves Lumley Ltd, 499 St Kilda Road, Melbourne	4,700.00	"	06.11.96
	7,045.60	"	11.07.95

98063

CONTACT: AMP GENERAL INSURANCE, PHONE: (02) 9257 5000.

**PROCLAMATIONS**

**Confiscation Act 1997**

PROCLAMATION OF COMMENCEMENT

I, James Gobbo, Governor of Victoria, acting with the advice of the Executive Council and under section 2(2) of the **Confiscation Act 1997** fix 1 July 1998 as the day on which the remaining provisions of that Act come into operation.

Given under my hand and the seal of  
Victoria on 23 June 1998.

(L.S.) JAMES GOBBO  
Governor  
By His Excellency's Command  
JAN WADE  
Attorney-General

**Property Law (Amendment) Act 1998**

PROCLAMATION OF COMMENCEMENT

I, James Gobbo, Governor of Victoria, acting with the advice of the Executive Council and under section 2(2) of the **Property Law (Amendment) Act 1998** fix 29 June 1998 as the day on which the remaining provisions of that Act come into operation.

Given under my hand and the seal of  
Victoria on 23 June 1998.

(L.S.) JAMES GOBBO  
Governor  
By His Excellency's Command  
JAN WADE  
Attorney-General

**Accident Compensation (Further  
Amendment) Act 1996**

PROCLAMATION OF COMMENCEMENT

I, James Gobbo, Governor of Victoria, acting with the advice of the Executive Council and under section 2(4) of the **Accident Compensation (Further Amendment) Act 1996**, fix 1 July 1998 as the day on which sections 21 and 32 of that Act come into operation.

Given under my hand and the seal of  
Victoria on 23 June 1998.

(L.S.) JAMES GOBBO  
Governor  
By His Excellency's Command  
ROGER M. HALLAM  
Minister for Finance

**Victorian Plantations Corporation  
(Amendment) Act 1998**

PROCLAMATION OF COMMENCEMENT

I, James Gobbo, Governor of Victoria, acting with the advice of the Executive Council and under section 2(2) of the **Victorian Plantations Corporation (Amendment) Act 1998**, fix:

- (a) 25 June 1998 as the day on which sections 5 and 11 of that Act come into operation; and
- (b) 26 June 1998 as the day on which the remaining provisions of that Act come into operation.

Given under my hand and the seal of  
Victoria on 23 June 1998.

(L.S.) JAMES GOBBO  
Governor  
By His Excellency's Command  
ALAN R. STOCKDALE  
Treasurer

**Gaming Acts (Miscellaneous Amendment)  
Act 1997**

PROCLAMATION OF COMMENCEMENT

I, James Gobbo, Governor of Victoria, acting with the advice of the Executive Council and under section 2(4) of the **Gaming Acts (Miscellaneous Amendment) Act 1997**, fix 30 June 1998 as the day on which section 20 of that Act comes into operation.

Given under my hand and the seal of  
Victoria on 23 June 1998.

(L.S.) JAMES GOBBO  
Governor  
By His Excellency's Command  
ROGER M. HALLAM  
Minister for Gaming

**Public Sector Management and  
Employment Act 1998**

PROCLAMATION OF COMMENCEMENT  
OF SPECIFIED PROVISIONS

I, James Gobbo, Governor of Victoria, with the advice of the Executive Council and under section 2(2) of the **Public Sector Management and Employment Act 1998**, fix 1 July 1998 as

the day on which the remaining provisions of that Act come into operation.

Given under my hand and the seal of  
Victoria on 23 June 1998.

(L.S.) JAMES GOBBO  
Governor  
By His Excellency's Command  
J. G. KENNETT  
Premier

**Ambulance Services (Amendment) Act 1998**  
PROCLAMATION OF COMMENCEMENT

I, James Gobbo, Governor of Victoria, acting with the advice of the Executive Council, and under section 2(2) of the **Ambulance Services (Amendment) Act 1998**, fix 30 June 1998 as the day on which sections 6(1), 6(2) (except for paragraphs (a) and (c) to (f)), 7(1), 8, 9, 10 and 14(2) of that Act come into operation.

Given under my hand and the seal of  
Victoria on 23 June 1998

(L.S.) JAMES GOBBO  
Governor  
By His Excellency's Command  
ROB KNOWLES  
Minister for Health

**Crimes (Sexual Offences) Act 1991**  
PROCLAMATION OF COMMENCEMENT

I, James Gobbo, Governor of Victoria, acting with the advice of the Executive Council and under section 2(1) of the **Crimes (Sexual Offences) Act 1991** fix 1 July 1998 as the day on which section 9 of that Act comes into operation.

Given under my hand and the seal of  
Victoria on 23 June 1998.

(L.S.) JAMES GOBBO  
Governor  
By His Excellency's Command  
JAN WADE MP  
Attorney- General

**Land Act 1958**

PROCLAMATION OF ROADS

I, James Gobbo, Governor of Victoria acting with the advice of the Executive Council and under Section 25(3)(c) of the **Land Act 1958** proclaim as roads the following lands:

MUNICIPAL DISTRICT OF THE  
SWAN HILL RURAL CITY COUNCIL

BOGA — Crown Allotment 1F, Section 3, Parish of Boga as shown on Certified Plan No. 118615 lodged in the Central Plan Office. — (1059/130).

MUNICIPAL DISTRICT OF THE  
CAMPASPE COUNCIL

PATHO — The land in the Parish of Patho shown by hatching on plan hereunder. — (P152[9]) (L6-10215).

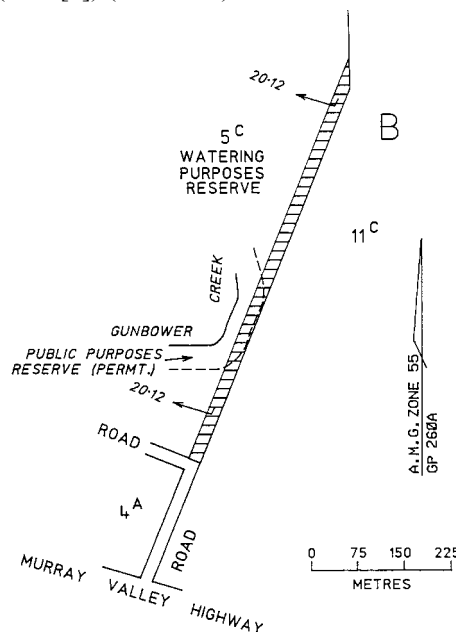

This Proclamation is effective from the date on which it is published in the Victoria Government Gazette.

Given under my hand and the seal of  
Victoria on 23 June 1998.

(L.S.) JAMES GOBBO  
Governor  
By His Excellency's Command  
MARIE TEHAN  
Minister for Conservation and  
Land Management



**Mental Health Act 1986**REVOCATION OF THE PROCLAMATION  
OF THE "BENDIGO HEALTH CARE  
GROUP DIVISION OF PSYCHIATRY"

I, James Gobbo, Governor of Victoria, acting with the advice of the Executive Council and under section 94 of the **Mental Health Act 1986**, fix 30 June 1998 as the day on which the proclamation made by the Governor in Council on 7 October 1997 of the "Bendigo Health Care Group Division of Psychiatry" as an approved mental health service pursuant to section 94(1) of the **Mental Health Act 1986**, is revoked.

Given under my hand and the seal of  
Victoria on 23 June 1998.

(L.S.) JAMES GOBBO  
Governor  
By His Excellency's Command  
ROB KNOWLES  
Minister for Health

**Mental Health Act 1986**PROCLAMATION OF THE "BENDIGO  
HEALTH CARE GROUP DIVISION OF  
PSYCHIATRY"

I, James Gobbo, Governor of Victoria, acting with the advice of the Executive Council and under section 94(1)(b) of the **Mental Health Act 1986**, fix 30 June 1998 as the day on which the Bendigo Health Care Group is to be proclaimed an approved mental health service known as the "Bendigo Health Care Group Division of Psychiatry".

Given under my hand and the seal of  
Victoria on 23 June 1998.

(L.S.) JAMES GOBBO  
Governor  
By His Excellency's Command  
ROB KNOWLES  
Minister for Health

**Mental Health Act 1986**REVOCATION OF THE PROCLAMATION  
OF THE "ROYAL CHILDREN'S HOSPITAL  
MENTAL HEALTH SERVICE,  
TRAVANCORE CAMPUS"

I, James Gobbo, Governor of Victoria, acting with the advice of the Executive Council and under section 94 of the **Mental Health Act 1986**, fix 25 June 1998 as the day on which the

proclamation of the "Royal Children's Hospital Mental Health Service, Travancore Campus", published in the Victoria Government Gazette No. 18, dated 9 May 1996 and amended by the proclamation published in the Gazette No. S. 59 on 30 May 1996, as an approved mental health service, pursuant to section 94(2) of the **Mental Health Act 1996**, is revoked.

Given under my hand and the seal of  
Victoria on 23 June 1998.

(L.S.) JAMES GOBBO  
Governor  
By His Excellency's Command  
ROB KNOWLES  
Minister for Health

**Mental Health Act 1986**REVOCATION OF THE PROCLAMATION  
OF "PHOENIX HOUSE"

I, James Gobbo, Governor of Victoria, acting with the advice of the Executive Council and under section 94 of the **Mental Health Act 1986**, fix 25 June 1998 as the day on which the proclamation made by the Governor in Council on 15 March 1989 of "Phoenix House" as an approved mental health service pursuant to section 94(2) of the **Mental Health Act 1986**, is revoked.

Given under my hand and the seal of  
Victoria on 23 June 1998.

(L.S.) JAMES GOBBO  
Governor  
By His Excellency's Command  
ROB KNOWLES  
Minister for Health

**Mental Health Act 1986**REVOCATION OF THE PROCLAMATION  
OF THE "WEST WARD, MAROONDAH  
HOSPITAL", KNOWN AS "MAROONDAH  
HOSPITAL PSYCHIATRIC UNIT"

I, James Gobbo, Governor of Victoria, acting with the advice of the Executive Council and under section 94 of the **Mental Health Act 1986**, fix 25 June 1998 as the day on which the proclamation of the "West Ward, Maroondah Hospital", known as "Maroondah Hospital Psychiatric Unit" published in the Victoria Government Gazette No. 48, dated 14 December 1988 as an approved mental health

service pursuant to section 94(2) of the **Mental Health Act 1986**, is revoked.

Given under my hand and the seal of  
Victoria on 23 June 1998.

(L.S.) JAMES GOBBO  
Governor  
By His Excellency's Command  
ROB KNOWLES  
Minister for Health

**Mental Health Act 1986**

REVOCATION OF THE PROCLAMATION  
OF THE "AUSTIN & REPATRIATION  
MEDICAL CENTRE ADULT PSYCHIATRIC  
UNIT"

I, James Gobbo, Governor of Victoria,  
acting with the advice of the Executive Council  
and under section 94 of the **Mental Health Act  
1986**, fix 25 June 1998 as the day on which the  
proclamation made by the Governor in Council  
on 23 January 1996 of the "Austin &  
Repatriation Medical Centre Adult Psychiatric  
Unit" as an approved mental health service  
pursuant to section 94(2) of the **Mental Health  
Act 1986**, is revoked.

Given under my hand and the seal of  
Victoria on 23 June 1998.

(L.S.) JAMES GOBBO  
Governor  
By His Excellency's Command  
ROB KNOWLES  
Minister for Health

**Mental Health Act 1986**

REVOCATION OF THE PROCLAMATION  
OF THE "AUSTIN & REPATRIATION  
MEDICAL CENTRE CHILD, ADOLESCENT  
AND FAMILY PSYCHIATRIC SERVICES"

I, James Gobbo, Governor of Victoria,  
acting with the advice of the Executive Council  
and under section 94 of the **Mental Health Act  
1986**, fix 25 June 1998 as the day on which the  
proclamation made by the Governor in Council  
on 23 January 1996 of the "Austin &  
Repatriation Medical Centre Child, Adolescent  
and Family Psychiatric Services" as an  
approved mental health service pursuant to  
section 94(2) of the **Mental Health Act 1986**, is  
revoked.

Given under my hand and the seal of  
Victoria on 23 June 1998.

(L.S.) JAMES GOBBO  
Governor  
By His Excellency's Command  
ROB KNOWLES  
Minister for Health

**Mental Health Act 1986**

REVOCATION OF THE PROCLAMATION  
OF THE "ROYAL TALBOT  
REHABILITATION CENTRE BRAIN  
DISORDERS AND INJURY SERVICE"

I, James Gobbo, Governor of Victoria,  
acting with the advice of the Executive Council  
and under section 94 of the **Mental Health Act  
1986**, fix 25 June 1998 as the day on which the  
proclamation made by the Governor in Council  
on 1 July 1997 of the "Royal Talbot  
Rehabilitation Centre Brain Disorders and  
Injury Service" as an approved mental health  
service pursuant to section 94(1) of the **Mental  
Health Act 1986**, is revoked.

Given under my hand and the seal of  
Victoria on 23 June 1998.

(L.S.) JAMES GOBBO  
Governor  
By His Excellency's Command  
ROB KNOWLES  
Minister for Health

**Mental Health Act 1986**

REVOCATION OF THE PROCLAMATION  
OF "DANDENONG PSYCHIATRIC  
CENTRE"

I, James Gobbo, Governor of Victoria,  
acting with the advice of the Executive Council  
and under section 94 of the **Mental Health Act  
1986**, fix 25 June 1998 as the day on which the  
proclamation of "Dandenong Psychiatric  
Centre" published in the Victoria Government  
Gazette dated 22 January 1992 as an approved  
mental health service pursuant to section 94(2)  
of the **Mental Health Act 1986**, is revoked.

Given under my hand and the seal of  
Victoria on 23 June 1998.

(L.S.) JAMES GOBBO  
Governor  
By His Excellency's Command  
ROB KNOWLES  
Minister for Health

**Mental Health Act 1986**  
REVOCATION OF THE PROCLAMATION  
OF "WESTERN HEALTH CARE  
NETWORK, ROYAL PARK HOSPITAL  
CAMPUS"

I, James Gobbo, Governor of Victoria, acting with the advice of the Executive Council and under section 94 of the **Mental Health Act 1986**, fix 25 June 1998 as the day on which the proclamation of "Western Health Care Network, Royal Park Hospital Campus" published in the Victoria Government Gazette No. 18, dated 9 May 1996 as an approved mental health service pursuant to section 94(2) of the **Mental Health Act 1986**, is revoked.

Given under my hand and the seal of  
Victoria on 23 June 1998.

(L.S.) JAMES GOBBO  
Governor  
By His Excellency's Command  
ROB KNOWLES  
Minister for Health

---

**Mental Health Act 1986**  
REVOCATION OF THE PROCLAMATION  
OF THE "UPTON HOUSE PSYCHIATRIC  
UNIT"

I, James Gobbo, Governor of Victoria, acting with the advice of the Executive Council and under section 94 of the **Mental Health Act 1986**, fix 25 June 1998 as the day on which the proclamation made by the Governor in Council on 28 March 1995 of the "Upton House Psychiatric Unit" as an approved mental health service pursuant to section 94(2) of the **Mental Health Act 1986**, is revoked.

Given under my hand and the seal of  
Victoria on 23 June 1998.

(L.S.) JAMES GOBBO  
Governor  
By His Excellency's Command  
ROB KNOWLES  
Minister for Health

---

**Mental Health Act 1986**  
REVOCATION OF THE PROCLAMATION  
OF THE "ADOLESCENT PSYCHIATRY  
INPATIENT UNIT OF THE MONASH  
MEDICAL CENTRE"

I, James Gobbo, Governor of Victoria, acting with the advice of the Executive Council and under section 94 of the **Mental Health Act**

**1986**, fix 25 June 1998 as the day on which the proclamation made by the Governor in Council on 13 December 1994 of the "Adolescent Psychiatry Inpatient Unit of the Monash Medical Centre" as an approved mental health service pursuant to section 94(2) of the **Mental Health Act 1986**, is revoked.

Given under my hand and the seal of  
Victoria on 23 June 1998.

(L.S.) JAMES GOBBO  
Governor  
By His Excellency's Command  
ROB KNOWLES  
Minister for Health

---

**Mental Health Act 1986**  
REVOCATION OF THE PROCLAMATION  
OF THE "ADULT PSYCHIATRY  
INPATIENT UNIT OF THE MONASH  
MEDICAL CENTRE"

I, James Gobbo, Governor of Victoria, acting with the advice of the Executive Council and under section 94 of the **Mental Health Act 1986**, fix 25 June 1998 as the day on which the proclamation made by the Governor in Council on 15 August 1995 of the "Adult Psychiatry Inpatient Unit of the Monash Medical Centre" as an approved mental health service pursuant to section 94(2) of the **Mental Health Act 1986**, is revoked.

Given under my hand and the seal of  
Victoria on 23 June 1998.

(L.S.) JAMES GOBBO  
Governor  
By His Excellency's Command  
ROB KNOWLES  
Minister for Health

---

**Mental Health Act 1986**  
REVOCATION OF THE PROCLAMATION  
OF THE "CENTRE FOR YOUNG PEOPLE'S  
MENTAL HEALTH"

I, James Gobbo, Governor of Victoria, acting with the advice of the Executive Council and under section 94 of the **Mental Health Act 1986**, fix 25 June 1998 as the day on which the proclamation of the "Centre for Young People's Mental Health" published in the Victoria Government Gazette No. 18, dated 9 May 1996 as an approved mental health service pursuant

to section 94(2) of the **Mental Health Act 1986**, is revoked.

Given under my hand and the seal of  
Victoria on 23 June 1998.

(L.S.) JAMES GOBBO  
Governor  
By His Excellency's Command

ROB KNOWLES  
Minister for Health

---

**Mental Health Act 1986**  
REVOCATION OF THE PROCLAMATION  
OF "RUSSELL HOUSE"

I, James Gobbo, Governor of Victoria, acting with the advice of the Executive Council and under section 94 of the **Mental Health Act 1986**, fix 25 June 1998 as the day on which the proclamation of "Russell House" published in the Victoria Government Gazette No. 49, dated 18 December 1991 as an approved mental health service pursuant to section 94(2) of the **Mental Health Act 1986**, is revoked.

Given under my hand and the seal of  
Victoria on 23 June 1998.

(L.S.) JAMES GOBBO  
Governor  
By His Excellency's Command

ROB KNOWLES  
Minister for Health

---

**Mental Health Act 1986**  
REVOCATION OF THE PROCLAMATION  
OF "THE ROYAL MELBOURNE  
HOSPITAL, WARD 1 NORTH"

I, James Gobbo, Governor of Victoria, acting with the advice of the Executive Council and under section 94 of the **Mental Health Act 1986**, fix 25 June 1998 as the day on which the proclamation of "The Royal Melbourne Hospital, Ward 1 North" published in the Victoria Government Gazette No. 18, dated 9 May 1996 as an approved mental health service pursuant to section 94(2) of the **Mental Health Act 1986**, is revoked.

Given under my hand and the seal of  
Victoria on 23 June 1998.

(L.S.) JAMES GOBBO  
Governor  
By His Excellency's Command

ROB KNOWLES  
Minister for Health

---

**Mental Health Act 1986**

REVOCATION OF THE PROCLAMATION  
OF THE "GIPPSLAND PSYCHIATRIC  
SERVICES UNIT"

I, James Gobbo, Governor of Victoria, acting with the advice of the Executive Council and under section 94 of the **Mental Health Act 1986**, fix 25 June 1998 as the day on which the proclamation made by the Governor in Council on 20 June 1995 of the "Gippsland Psychiatric Services Unit" as an approved mental health service pursuant to section 94(2) of the **Mental Health Act 1986**, is revoked.

Given under my hand and the seal of  
Victoria on 23 June 1998.

(L.S.) JAMES GOBBO  
Governor  
By His Excellency's Command

ROB KNOWLES  
Minister for Health

---

**Mental Health Act 1986**

REVOCATION OF THE PROCLAMATION  
OF THE "FRANKSTON HOSPITAL  
PSYCHIATRIC UNIT"

I, James Gobbo, Governor of Victoria, acting with the advice of the Executive Council and under section 94 of the **Mental Health Act 1986**, fix 25 June 1998 as the day on which the proclamation of "Frankston Hospital Psychiatric Unit" published in the Victoria Government Gazette No. 47, dated 4 December 1991 as an approved mental health service pursuant to section 94(2) of the **Mental Health Act 1986**, is revoked.

Given under my hand and the seal of  
Victoria on 23 June 1998.

(L.S.) JAMES GOBBO  
Governor  
By His Excellency's Command

ROB KNOWLES  
Minister for Health

---

**Mental Health Act 1986**

PROCLAMATION OF "CENTRE FOR  
YOUNG PEOPLE'S MENTAL HEALTH"

I, James Gobbo, Governor of Victoria, acting with the advice of the Executive Council and under section 94(1)(b) of the **Mental Health Act 1986**, fix 25 June 1998 as the day

on which "Centre for Young People's Mental Health" at 35 Poplar Road, Parkville is proclaimed an approved mental health service known as "Centre for Young People's Mental Health".

Given under my hand and the seal of  
Victoria on 23 June 1998.

(L.S.) JAMES GOBBO  
Governor  
By His Excellency's Command

ROB KNOWLES  
Minister for Health

---

**Mental Health Act 1986**  
PROCLAMATION OF MILDURA BASE  
HOSPITAL

I, James Gobbo, Governor of Victoria, acting with the advice of the Executive Council and under section 94(1)(b) of the **Mental Health Act 1986**, fix 25 June 1998 as the day on which Mildura Base Hospital is to be proclaimed an approved mental health service known as "Northern Mallee Area Mental Health Service".

Given under my hand and the seal of  
Victoria on 23 June 1998.

(L.S.) JAMES GOBBO  
Governor  
By His Excellency's Command

ROB KNOWLES  
Minister for Health

---

**Mental Health Act 1986**  
PROCLAMATION OF "ROYAL PARK  
HOSPITAL"

I, James Gobbo, Governor of Victoria, acting with the advice of the Executive Council and under section 94(1)(b) of the **Mental Health Act 1986**, fix 25 June 1998 as the day on which "Royal Park Hospital" at Park Street, Parkville is to be proclaimed an approved mental health service known as "North Western Health Care Network, Royal Park Hospital Mental Health Services".

Given under my hand and the seal of  
Victoria on 23 June 1998.

(L.S.) JAMES GOBBO  
Governor  
By His Excellency's Command

ROB KNOWLES  
Minister for Health

---

**Mental Health Act 1986**  
PROCLAMATION OF "GIPPSLAND  
PSYCHIATRIC SERVICES"

I, James Gobbo, Governor of Victoria, acting with the advice of the Executive Council and under section 94(1)(b) of the **Mental Health Act 1986**, fix 25 June 1998 as the day on which the Latrobe Regional Hospital is to be proclaimed an approved mental health service known as "Gippsland Psychiatric Services".

Given under my hand and the seal of  
Victoria on 23 June 1998.

(L.S.) JAMES GOBBO  
Governor  
By His Excellency's Command

ROB KNOWLES  
Minister for Health

---

**Mental Health Act 1986**  
PROCLAMATION OF "PENINSULA  
HEALTH CARE NETWORK"

I, James Gobbo, Governor of Victoria, acting with the advice of the Executive Council and under section 94(1)(b) of the **Mental Health Act 1986**, fix 25 June 1998 as the day on which "Peninsula Health Care Network" is to be proclaimed an approved mental health service known as "Peninsula Health Care Network".

Given under my hand and the seal of  
Victoria on 23 June 1998.

(L.S.) JAMES GOBBO  
Governor  
By His Excellency's Command

ROB KNOWLES  
Minister for Health

---

**Mental Health Act 1986**  
PROCLAMATION OF "WOMEN'S AND  
CHILDREN'S HEALTH CARE NETWORK  
MENTAL HEALTH SERVICES"

I, James Gobbo, Governor of Victoria, acting with the advice of the Executive Council and under section 94(1)(b) of the **Mental Health Act 1986**, fix 25 June 1998 as the day on which Women's and Children's Health Care Network is to be proclaimed an approved mental health service known as "Women's and Children's Health Care Network Mental Health Services".

Given under my hand and the seal of  
Victoria on 23 June 1998.

(L.S.) JAMES GOBBO  
Governor  
By His Excellency's Command  
ROB KNOWLES  
Minister for Health

**Mental Health Act 1986**

PROCLAMATION OF THE "PETER JAMES  
CENTRE AGED PSYCHIATRY SERVICE"

I, James Gobbo, Governor of Victoria,  
acting with the advice of the Executive Council  
and under section 94(1)(b) of the **Mental  
Health Act 1986**, fix 25 June 1998 as the day  
on which the Peter James Centre at Mahoneys  
Road, East Burwood, 3151, is to be proclaimed  
an approved mental health service known as the  
"Peter James Centre Aged Psychiatry Service".

Given under my hand and the seal of  
Victoria on 23 June 1998.

(L.S.) JAMES GOBBO  
Governor  
By His Excellency's Command  
ROB KNOWLES  
Minister for Health

**Mental Health Act 1986**

PROCLAMATION OF "MAROONDAH  
HOSPITAL"

I, James Gobbo, Governor of Victoria,  
acting with the advice of the Executive Council  
and under section 94(1)(b) of the **Mental  
Health Act 1986**, fix 25 June 1998 as the day  
on which "Maroondah Hospital" at Davey  
Drive, East Ringwood is to be proclaimed an  
approved mental health service known as the  
"Maroondah Hospital Psychiatric Service".

Given under my hand and the seal of  
Victoria on 23 June 1998.

(L.S.) JAMES GOBBO  
Governor  
By His Excellency's Command  
ROB KNOWLES  
Minister for Health

**Mental Health Act 1986**

PROCLAMATION OF "PSYCHIATRY AND  
PSYCHOLOGY CLINICAL SERVICES,  
AUSTIN AND REPATRIATION MEDICAL  
CENTRE"

I, James Gobbo, Governor of Victoria,  
acting with the advice of the Executive Council  
and under section 94(1)(b) of the **Mental**

**Health Act 1986**, fix 25 June 1998 as the day  
on which the Austin and Repatriation Medical  
Centre is to be proclaimed an approved mental  
health service known as "Psychiatry and  
Psychology Clinical Services, Austin and  
Repatriation Medical Centre".

Given under my hand and the seal of  
Victoria on 23 June 1998.

(L.S.) JAMES GOBBO  
Governor  
By His Excellency's Command  
ROB KNOWLES  
Minister for Health

**Mental Health Act 1986**

PROCLAMATION OF "DANDENONG  
HOSPITAL"

I, James Gobbo, Governor of Victoria,  
acting with the advice of the Executive Council  
and under section 94(1)(b) of the **Mental  
Health Act 1986**, fix 25 June 1998 as the day  
on which "Dandenong Hospital" at David  
Street, Dandenong is to be proclaimed an  
approved mental health service known as the  
"Dandenong Area Mental Health Service".

Given under my hand and the seal of  
Victoria on 23 June 1998.

(L.S.) JAMES GOBBO  
Governor  
By His Excellency's Command  
ROB KNOWLES  
Minister for Health

**Mental Health Act 1986**

PROCLAMATION OF "THE ROYAL  
MELBOURNE HOSPITAL"

I, James Gobbo, Governor of Victoria,  
acting with the advice of the Executive Council  
and under section 94(1)(b) of the **Mental  
Health Act 1986**, fix 25 June 1998 as the day  
on which "The Royal Melbourne Hospital" at  
Grattan Street, Parkville is to be proclaimed an  
approved mental health service known as  
"North Western Health Care Network, Royal  
Melbourne Hospital Mental Health Service".

Given under my hand and the seal of  
Victoria on 23 June 1998.

(L.S.) JAMES GOBBO  
Governor  
By His Excellency's Command  
ROB KNOWLES  
Minister for Health

**Mental Health Act 1986**

PROCLAMATION OF "CENTRAL EAST  
AREA MENTAL HEALTH SERVICE"

I, James Gobbo, Governor of Victoria, acting with the advice of the Executive Council and under section 94(1)(b) of the **Mental Health Act 1986**, fix 25 June 1998 as the day on which Upton House at 131 Thames Street, Box Hill, 3128, is to be proclaimed an approved mental health service known as "Central East Area Mental Health Service".

Given under my hand and the seal of  
Victoria on 23 June 1998.

(L.S.) JAMES GOBBO  
Governor  
By His Excellency's Command  
ROB KNOWLES  
Minister for Health

---

**Mental Health Act 1986**

PROCLAMATION OF "MIDDLE SOUTH  
AREA MENTAL HEALTH SERVICE"

I, James Gobbo, Governor of Victoria, acting with the advice of the Executive Council and under section 94(1)(b) of the **Mental Health Act 1986** fix 25 June 1998 as the day on which the Monash Medical Centre at 246 Clayton Road, Clayton, 3168, is to be proclaimed an approved mental health service known as "Middle South Area Mental Health Service".

Given under my hand and the seal of  
Victoria on 23 June 1998.

(L.S.) JAMES GOBBO  
Governor  
By His Excellency's Command  
ROB KNOWLES  
Minister for Health

---

**Reference Areas Act 1978**

PROCLAMATION OF REFERENCE AREAS

I, James Gobbo, Governor of Victoria, acting with the advice of the Executive Council and on the recommendation of the Minister for Conservation and Land Management, proclaim under section 4 of the **Reference Areas Act 1978**, the areas of public land shown by hatching on each of the plans in Schedules 1 to 28 (inclusive) hereunder (the originals of which are lodged at Natural Resource Systems, Department of Natural Resources and Environment, 121 William Street, Melbourne, 3000) to be reference areas to be known by the names specified in each schedule:

**SCHEDULE 1**



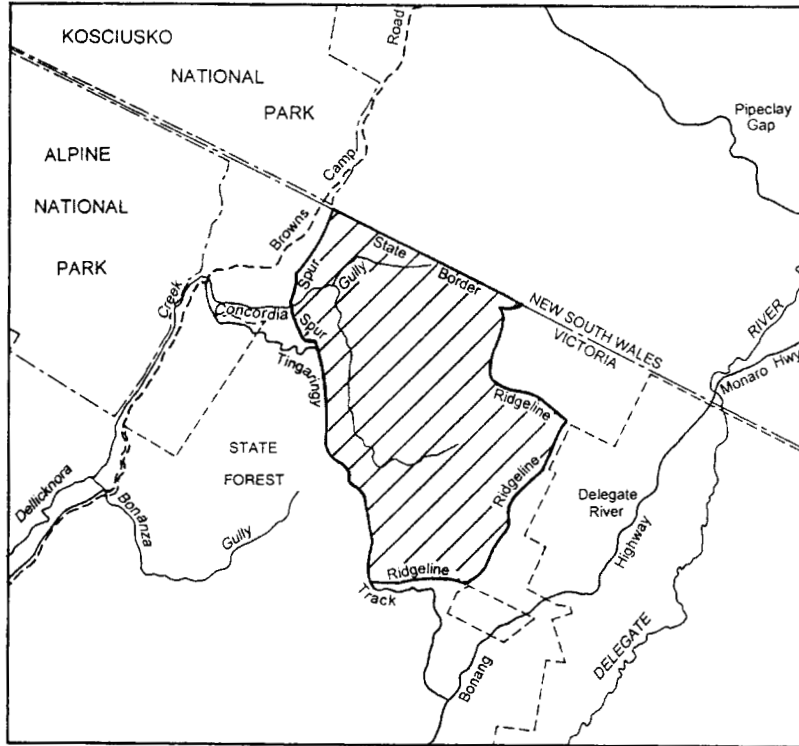



The public land shown on the plan numbered RA 20, to be known as the Concordia Gully Reference Area;

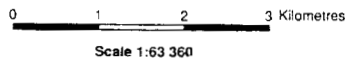

**CONCORDIA GULLY REFERENCE AREA**

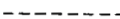
Parish of Cabanandra



- REFERENCE AREA 
- Major Road 
- Minor Road 
- Track 
- Park Boundary 
- Watercourse 
- Private Land Boundary 



Locality Plan

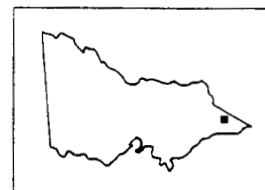

Map Number RA 20



**SCHEDULE 2**

The public land shown on the plan numbered RA 54, to be known as the Tambo River Reference Area;

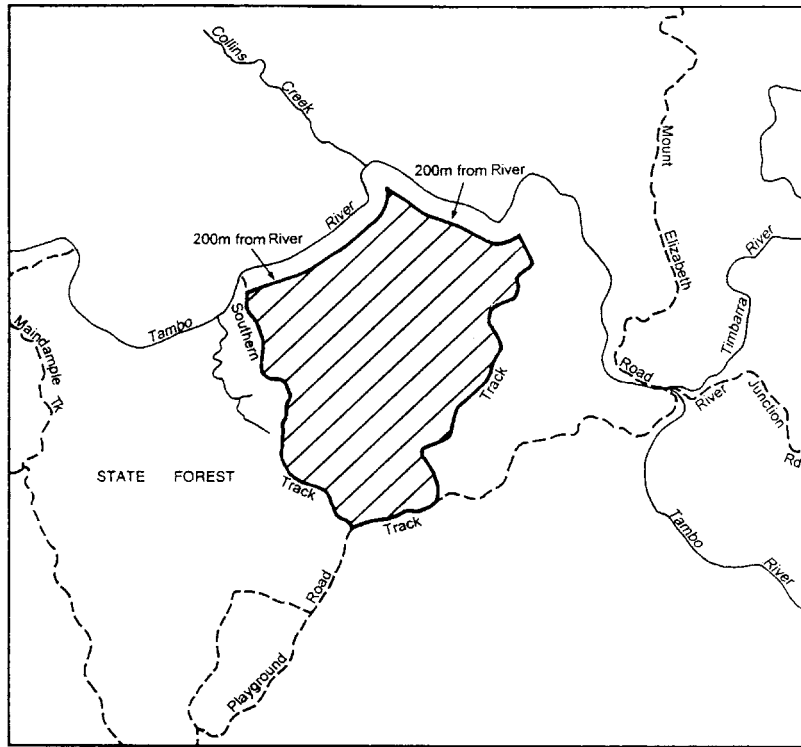





**TAMBO RIVER REFERENCE AREA**

Parish of Yonduk

0 1 2 3 Kilometres

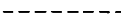
Scale 1:50 000

- REFERENCE AREA 
- Major Road 
- Minor Road 
- Track 
- Park Boundary 
- Watercourse 



Locality Plan

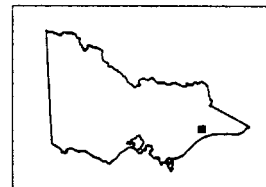

Map Number RA 54

**SCHEDULE 3**

The public land shown on the plan numbered RA 58, to be known as the Twenty Acre Creek Reference Area;

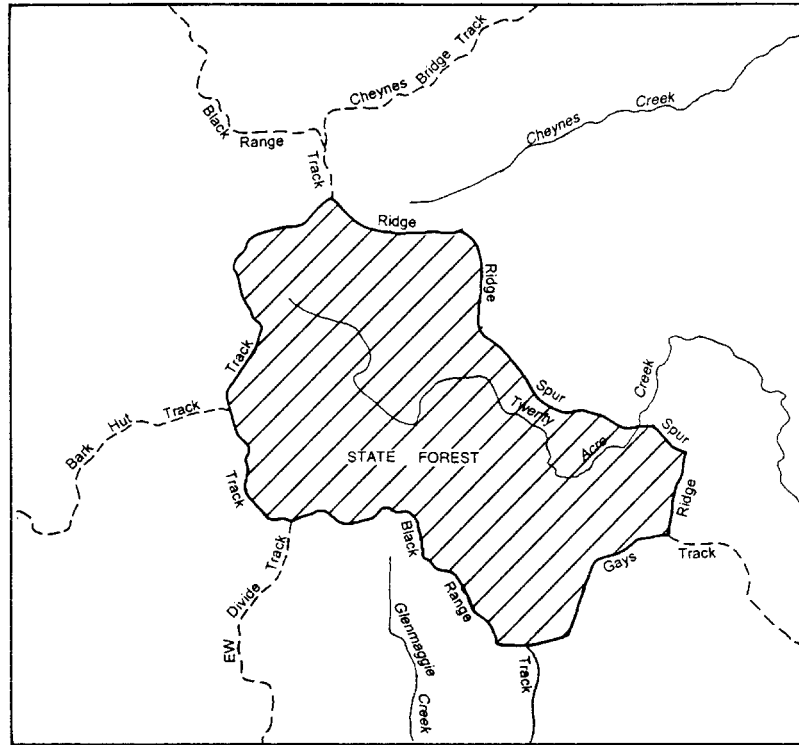

**TWENTY ACRE CREEK REFERENCE AREA**

Parishes of Yangourra & Narrobruk

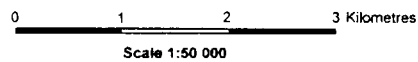

- REFERENCE AREA
- Major Road
- Minor Road
- Track
- Park Boundary
- Watercourse



Locality Plan

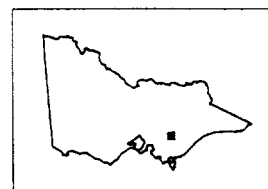

Map Number RA 58

**SCHEDULE 4**



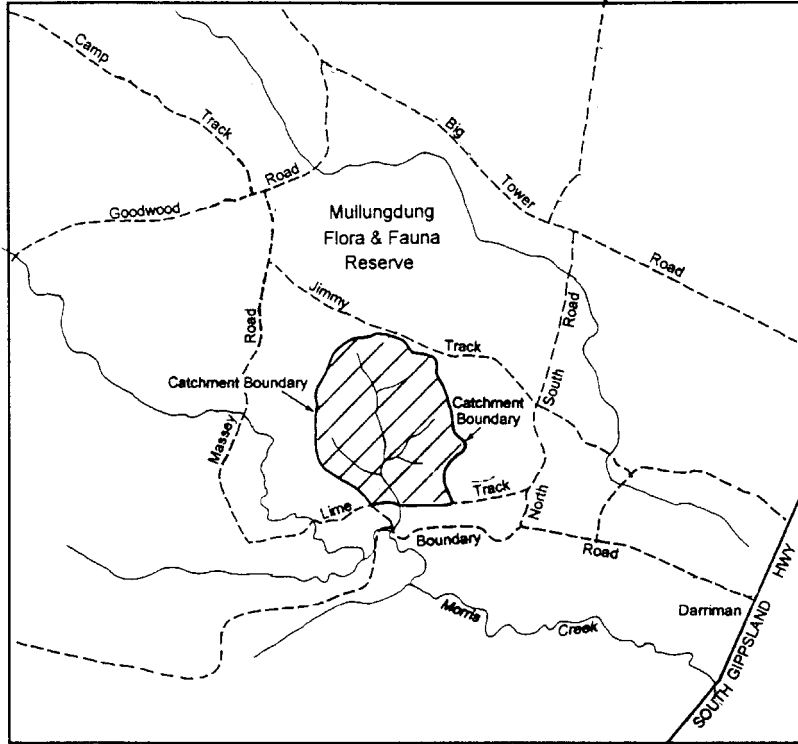



The public land shown on the plan numbered RA 70, to be known as the Mullungdung Reference Area;

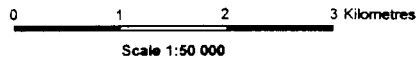

**MULLUNGDUNG REFERENCE AREA**

Parish of Mullungdung



- REFERENCE AREA 
- Major Road 
- Minor Road 
- Track 
- Park Boundary 
- Watercourse 



Locality Plan

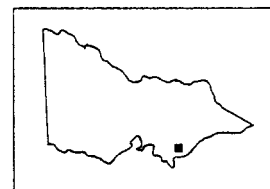

Map Number RA 70

SCHEDULE 5

The public land shown on the plan numbered RA 71, to be known as the Musket Creek Reference Area;

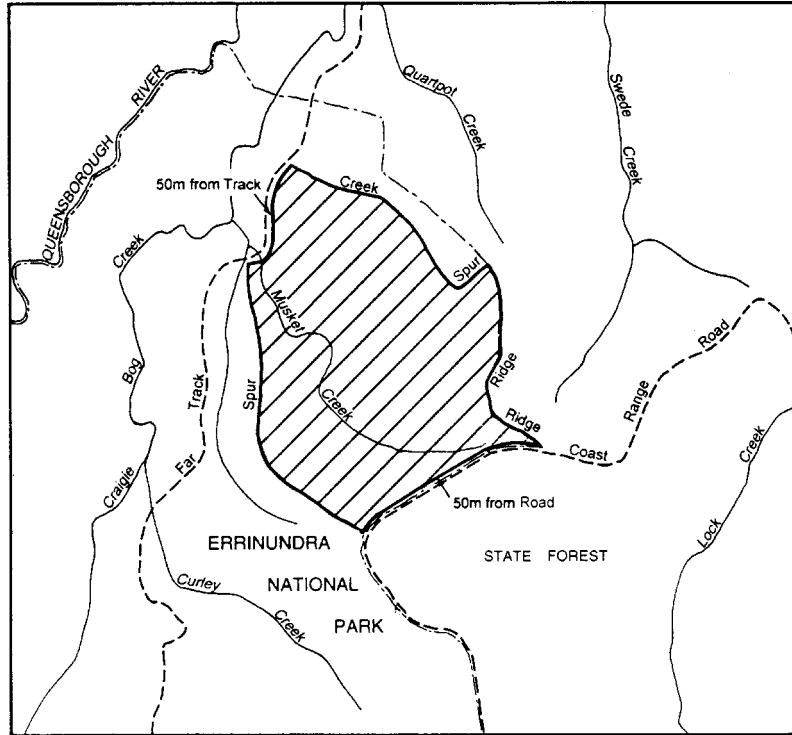



MUSKET CREEK REFERENCE AREA

Parish of Errinundra

0 1 2 3 Kilometres

Scale 1:50 000

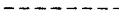
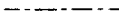
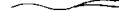
- REFERENCE AREA 
- Major Road 
- Minor Road 
- Track 
- Park Boundary 
- Watercourse 



Locality Plan

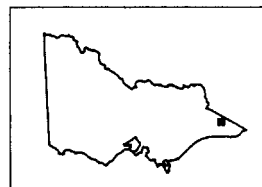

Map Number RA 71

**SCHEDULE 6**

The public land shown on the plan numbered RA 57, to be known as the Stringybark Creek Reference Area;

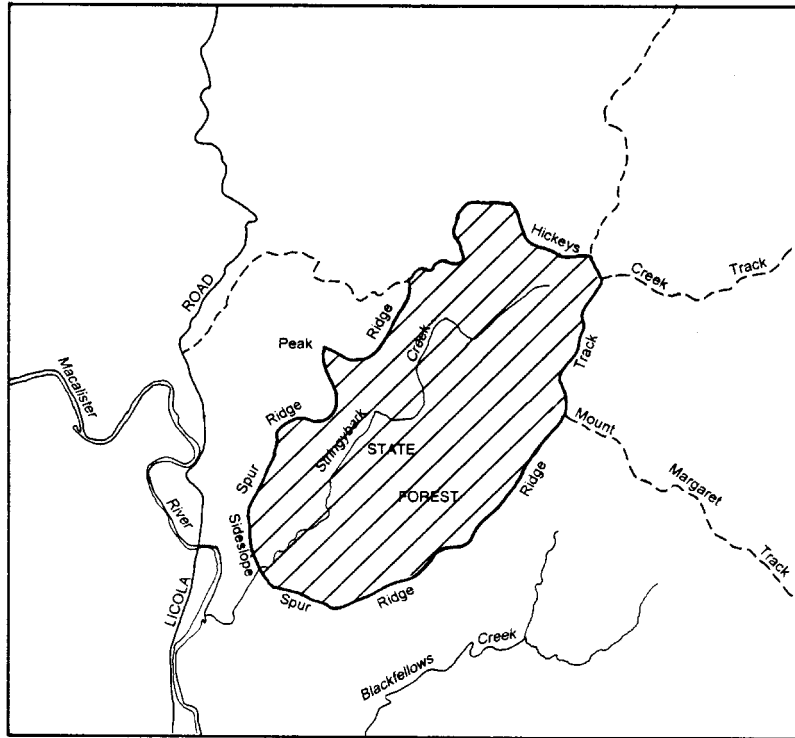

**STRINGYBARK CREEK REFERENCE AREA**

Parish of Giltum

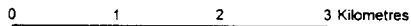

Scale 1:50 000

REFERENCE AREA



Major Road



Minor Road



Track

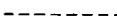

Park Boundary



Watercourse



Locality Plan

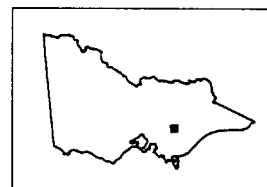

Map Number RA 57

### SCHEDULE 7

The public land shown on the plan numbered RA 59, to be known as the Thirteen Mile Spur Reference Area;

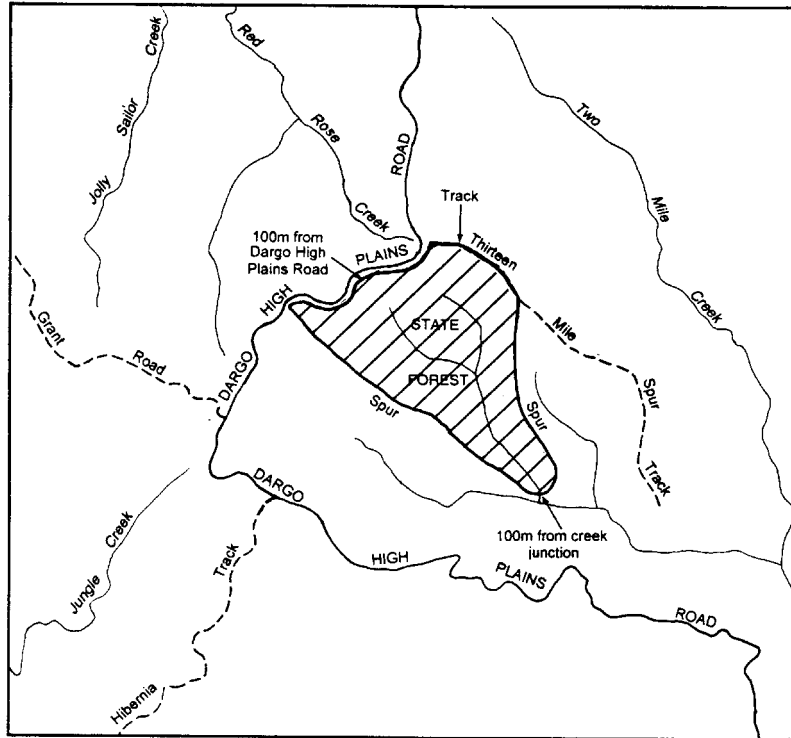

### THIRTEEN MILE SPUR REFERENCE AREA

Parishes of Wongungarra and Tarkeeth

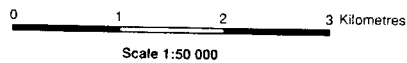

- |                |  |
|----------------|--|
| REFERENCE AREA |  |
| Major Road     |  |
| Minor Road     |  |
| Track          |  |
| Park Boundary  |  |
| Watercourse    |  |



Locality Plan

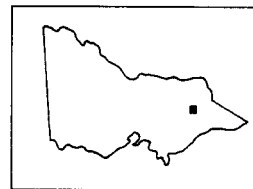

Map Number RA 59

**SCHEDULE 8**

The public land shown on the plan numbered RA 69, to be known as the Entrance Point Reference Area;

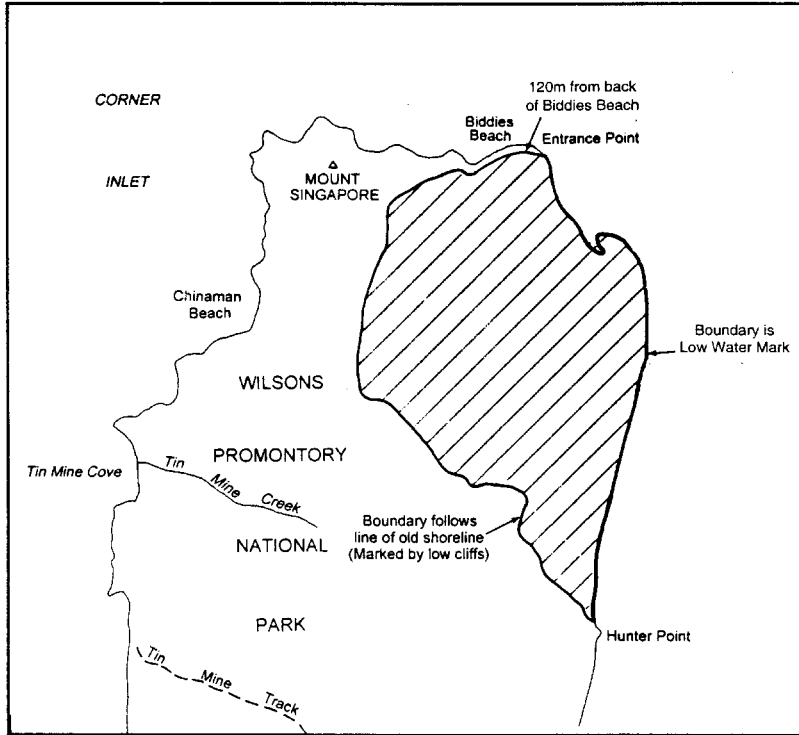

**ENTRANCE POINT REFERENCE AREA**

Parish of Warreen

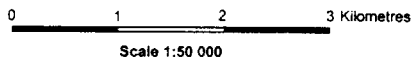

REFERENCE AREA 

Major Road 

Minor Road 

Track 

Park Boundary 

Watercourse 



Locality Plan

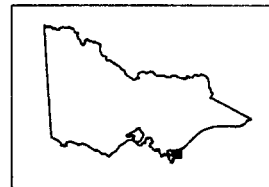

Map Number RA 69

**SCHEDULE 9**



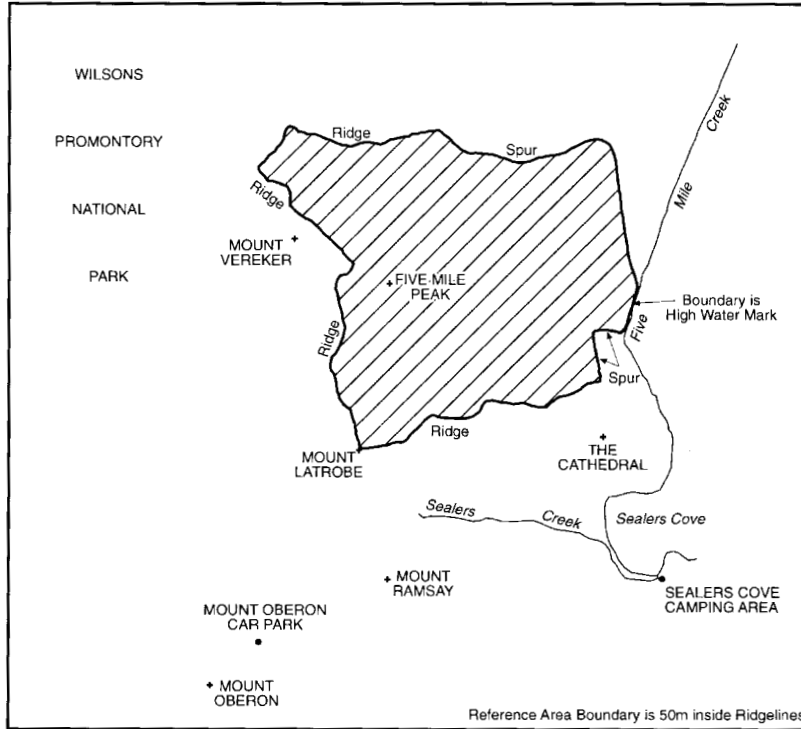



The public land shown on the plan numbered RA 92, to be known as the Vereker Creek Reference Area;

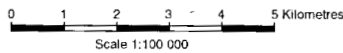

**VEREKER CREEK REFERENCE AREA**

Parishes of Beek Beek and Kulk



- REFERENCE AREA 
- Major Road 
- Minor Road 
- Track 
- Park Boundary 
- Watercourse 



Locality Plan

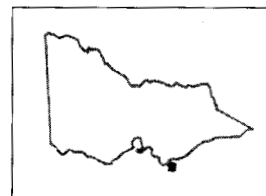

Map Number RA 92



**SCHEDULE 10**

The public land shown on the plan numbered RA 67, to be known as the Macks Creek Reference Area;

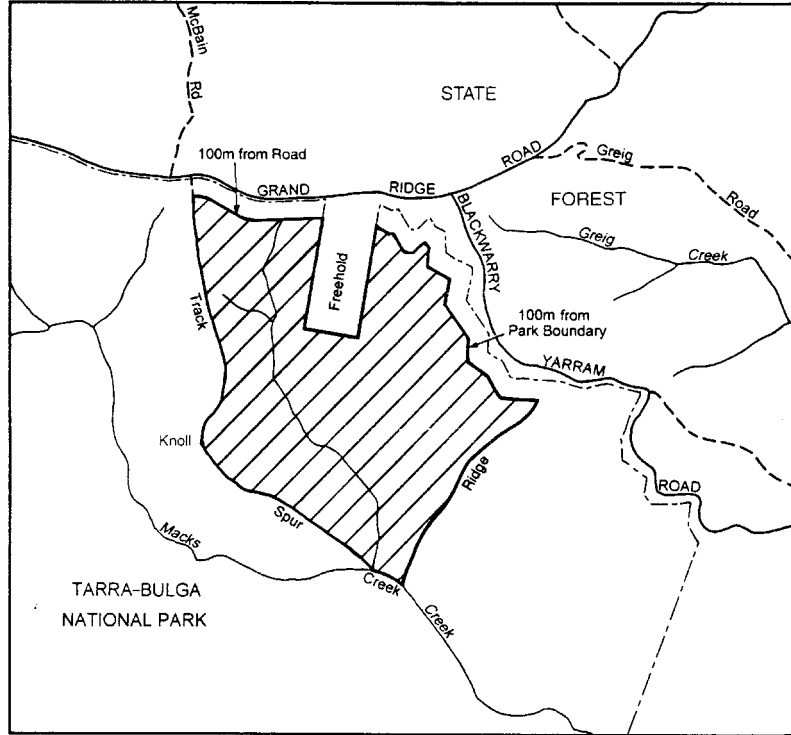





**MACKS CREEK REFERENCE AREA**

Parish of Bulga

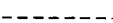
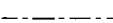

Scale 1:25 000

- REFERENCE AREA 
- Major Road 
- Minor Road 
- Track 
- Park Boundary 
- Watercourse 



Locality Plan

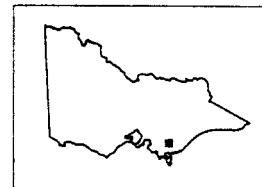

Map Number RA 67





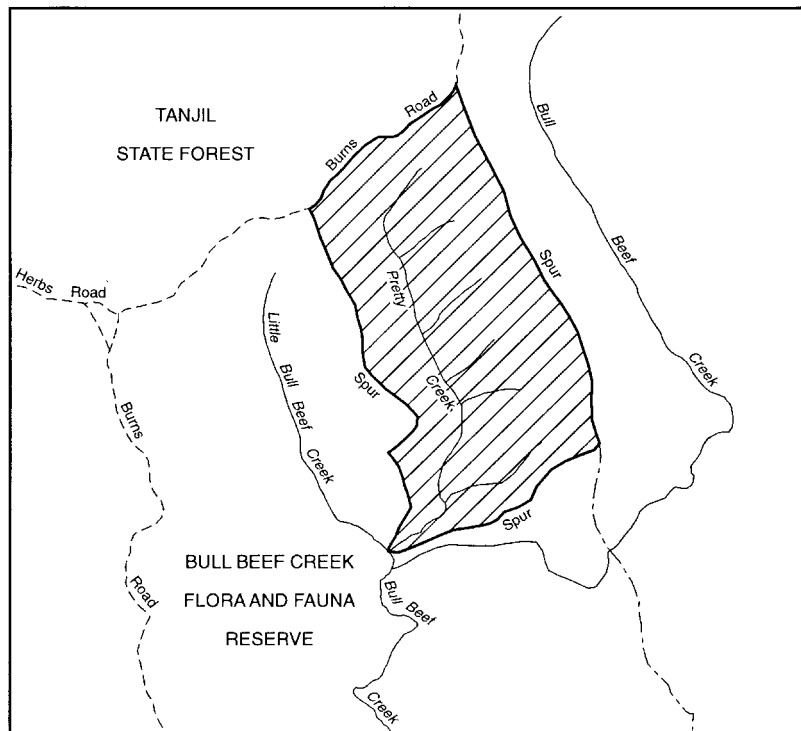

**SCHEDULE 11**

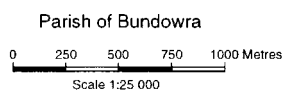
The public land shown on the plan numbered RA 91, to be known as the Pretty Creek Reference Area;



**PRETTY CREEK REFERENCE AREA**



- REFERENCE AREA 
- Major Road 
- Minor Road 
- Track 
- Park Boundary 
- Watercourse 

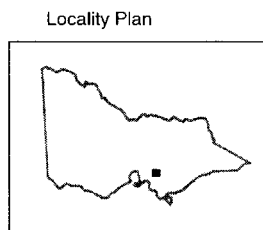

Map Number RA 91

**SCHEDULE 12**



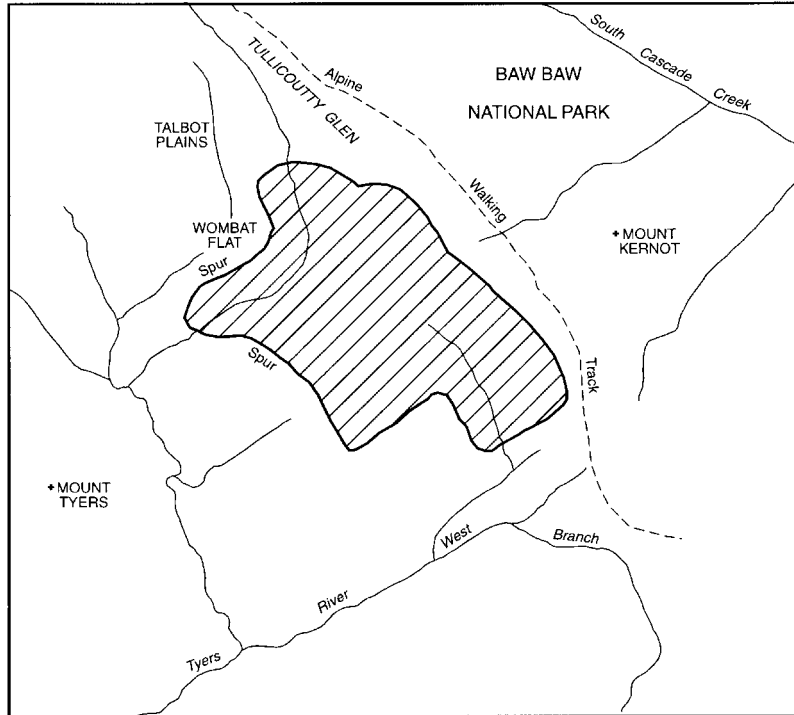

The public land shown on the plan numbered RA 90, to be known as the Baw Baw Reference Area;

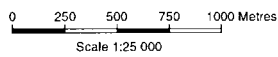

**BAW BAW REFERENCE AREA**

Parishes of Baw Baw and Telbit

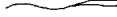

- REFERENCE AREA 
- Major Road 
- Minor Road 
- Track 
- Park Boundary 
- Watercourse 



Locality Plan

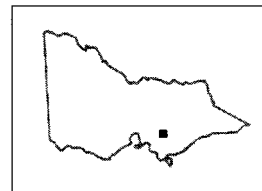

Map Number RA 90

This replaces the plan for the Baw Baw Reference Area published in Government Gazette No. 130, 22 December 1978, page 4129.

**SCHEDULE 13**

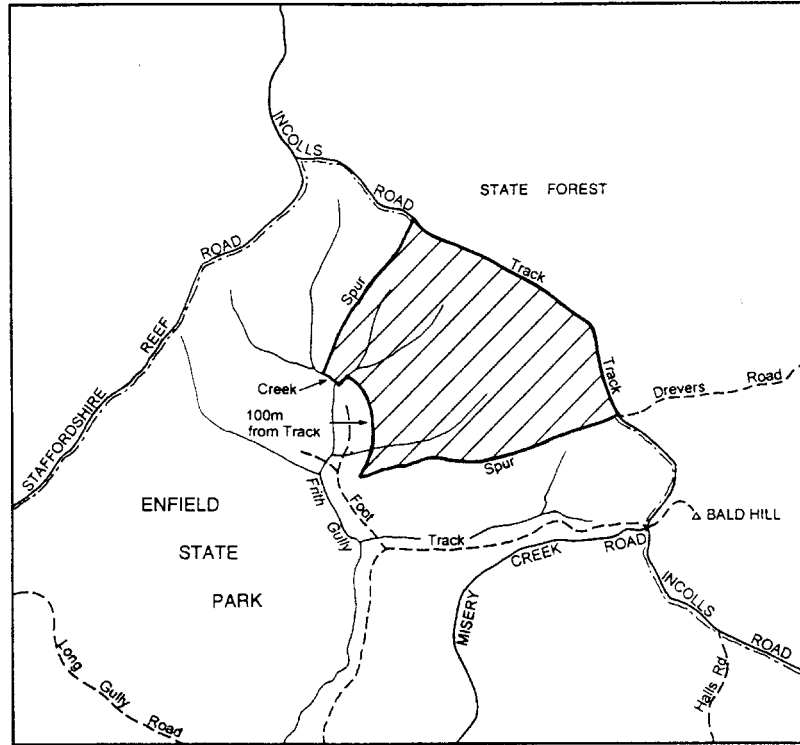

The public land shown on the plan numbered RA 74, to be known as the Enfield Reference Area;



**ENFIELD REFERENCE AREA**

Parish of Lynchfield

0 250 500 750 1000 Metres

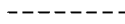
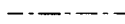
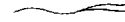
- REFERENCE AREA 
- Major Road 
- Minor Road 
- Track 
- Park Boundary 
- Watercourse 



Locality Plan

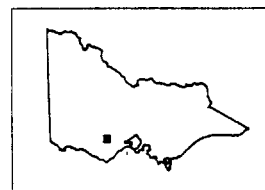

Map Number RA 74

**SCHEDULE 14**

The public land shown on the plan numbered RA 76, to be known as the Crinoline Creek Reference Area;

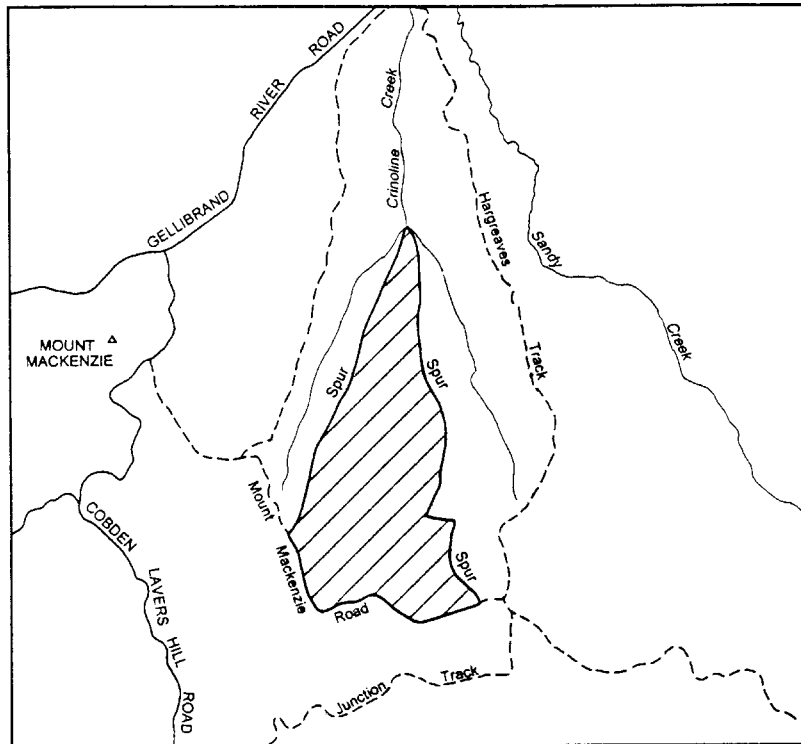

**CRINOLINE CREEK REFERENCE AREA**

Parish of Moomowroong

0 1 2 3 Kilometres

Scale 1:50 000

REFERENCE AREA



Major Road



Minor Road

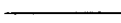

Track

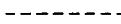

Park Boundary

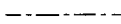

Watercourse



Locality Plan

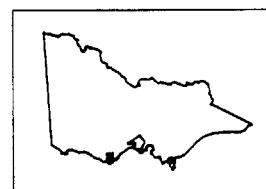

Map Number RA 76

**SCHEDULE 15**



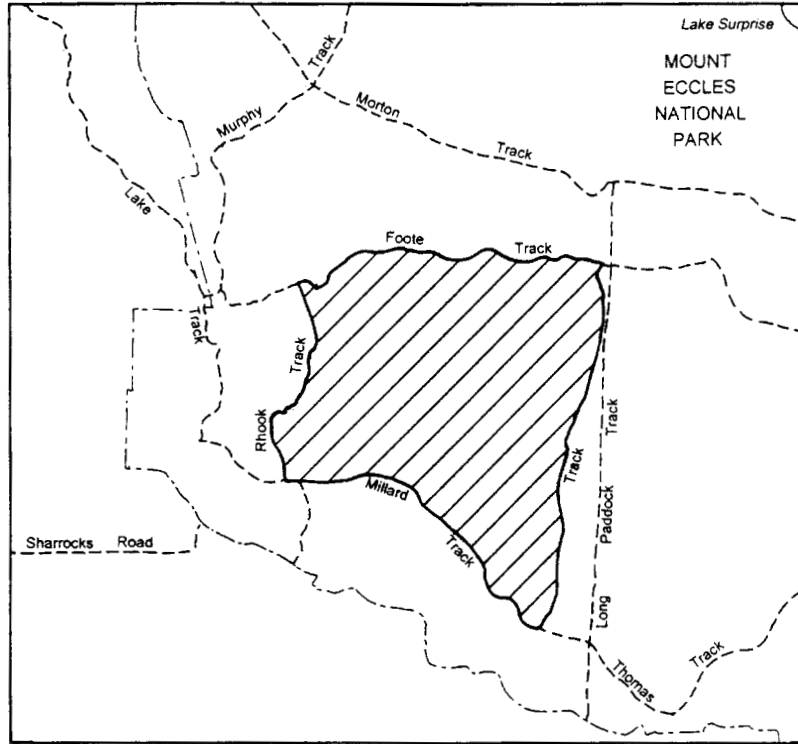



The public land shown on the plan numbered RA 77, to be known as The Stones Reference Area;

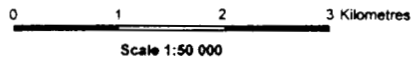

**THE STONES REFERENCE AREA**

Parish of Dunmore

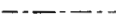

- REFERENCE AREA 
- Major Road 
- Minor Road 
- Track 
- Park Boundary 
- Watercourse 



Locality Plan

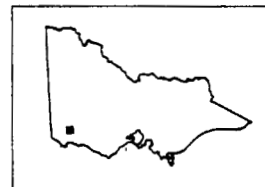

Map Number RA 77



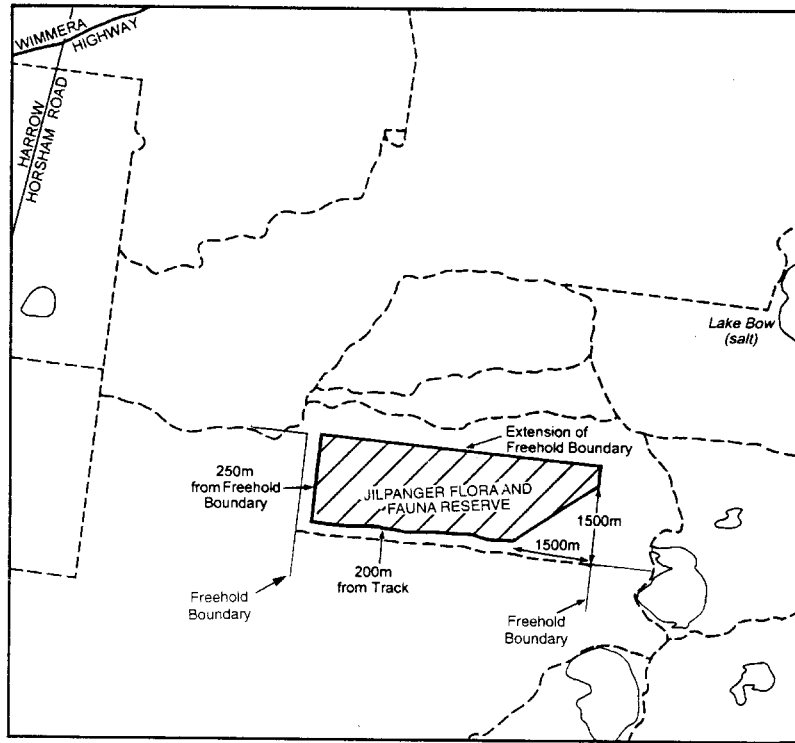

**SCHEDULE 16**

The public land shown on the plan numbered RA 83, to be known as the Jilpanger Reference Area;

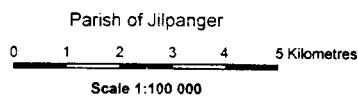

**JILPANGER REFERENCE AREA**

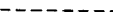
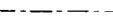

- REFERENCE AREA 
- Major Road 
- Minor Road 
- Track 
- Park Boundary 
- Watercourse 



Locality Plan

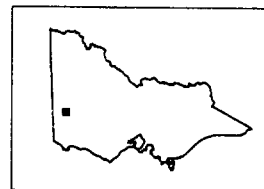

Map Number RA 83

**SCHEDULE 17**



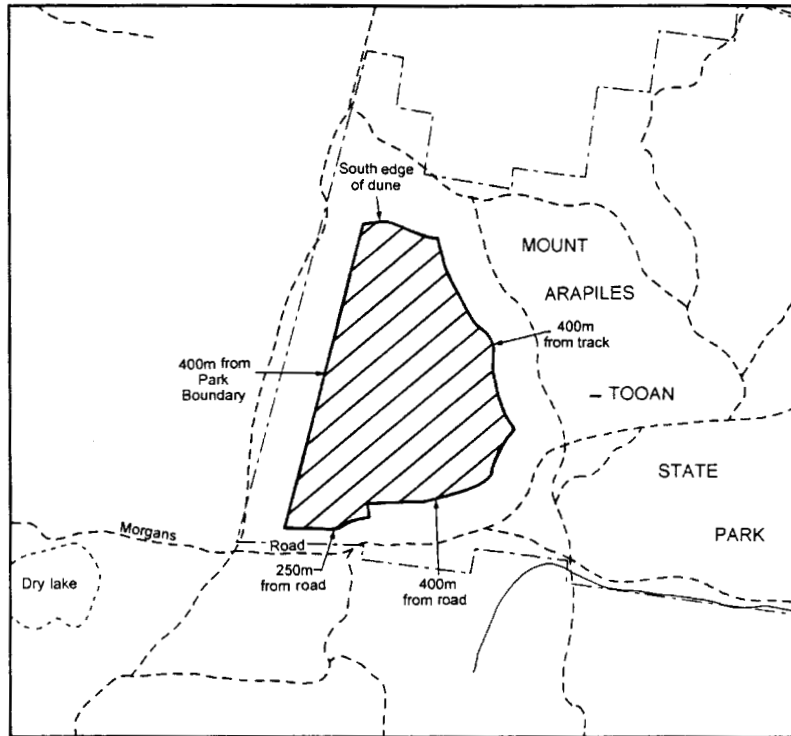



The public land shown on the following plan, RA 88, to be known as the Toosan Reference Area;

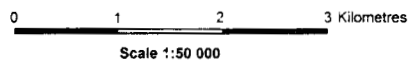

**TOOAN REFERENCE AREA**

Parish of Gymbowen



- REFERENCE AREA 
- Major Road 
- Minor Road 
- Track 
- Park Boundary 
- Watercourse 



Locality Plan

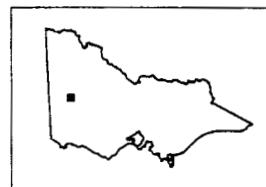

Map Number RA 88



**SCHEDULE 18**



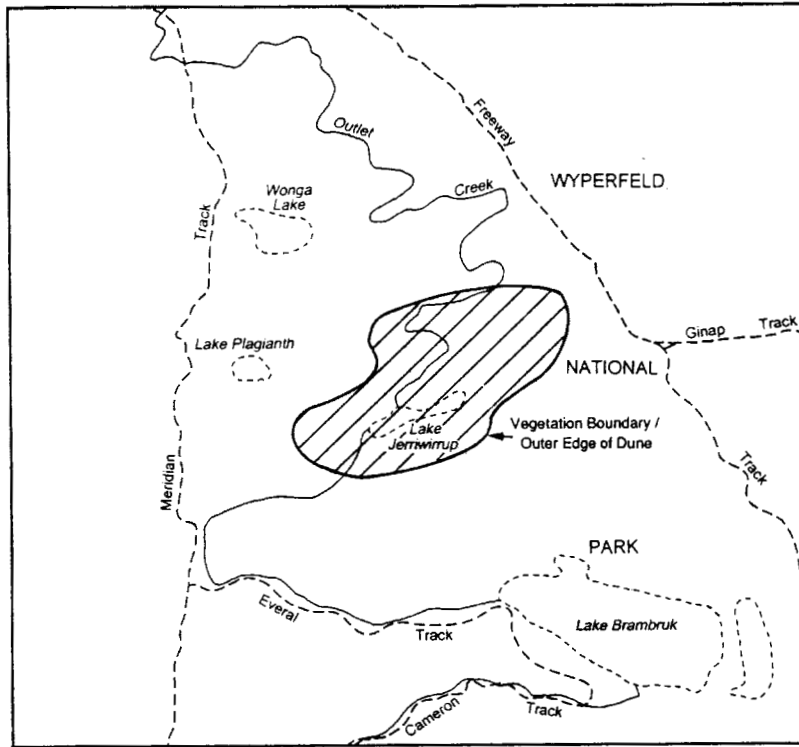

The public land shown on the following plan, RA 25, to be known as the Lake Jerriwirrup Reference Area;

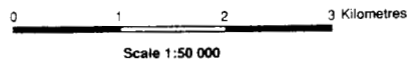

**LAKE JERRIWIRUP REFERENCE AREA**

Parish of Ginap

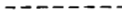

- REFERENCE AREA 
- Major Road 
- Minor Road 
- Track 
- Park Boundary 
- Watercourse 



Locality Plan

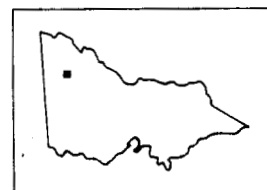

Map Number RA 25

**SCHEDULE 19**

The public land shown on the following plan, RA 26, to be known as the Lake Wallawalla Reference Area;

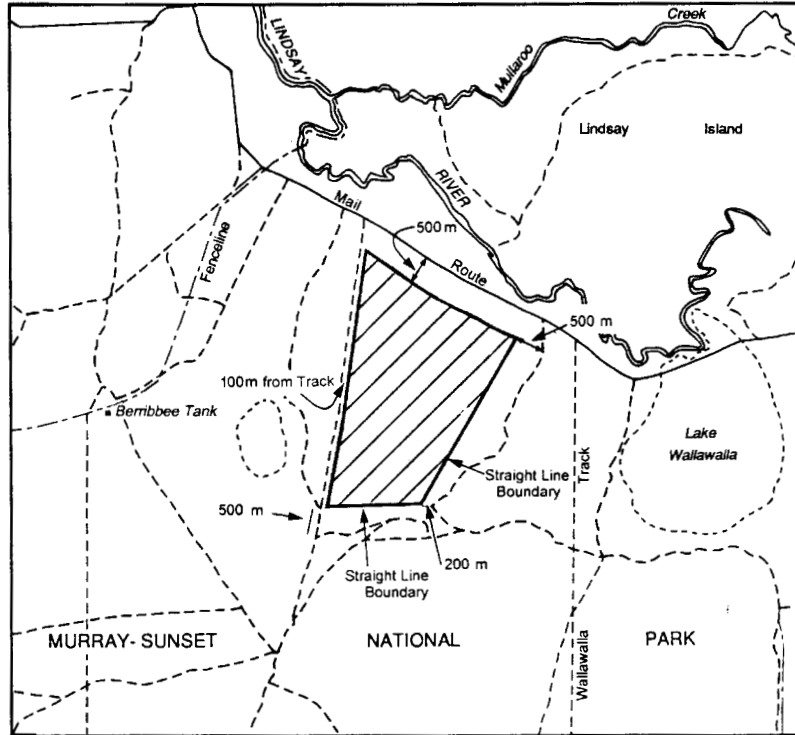



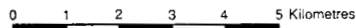

**LAKE WALLAWALLA REFERENCE AREA**

Parish of Woolwoola

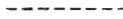

Scale 1:100 000

- REFERENCE AREA 
- Major Road 
- Minor Road 
- Track 
- Park Boundary 
- Watercourse 



Locality Plan

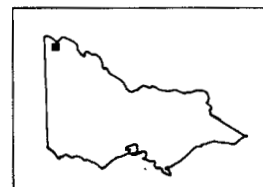

Map Number RA 26

**SCHEDULE 20**

The public land shown on the following plan, RA 30, to be known as the Kia Reference Area;

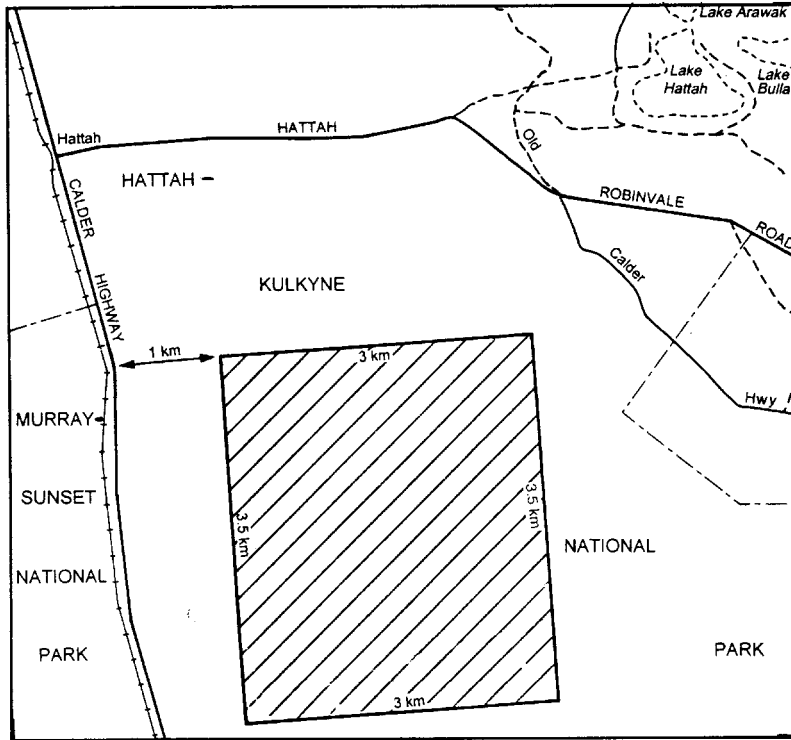

**KIA REFERENCE AREA**

Parish of Mournpouli

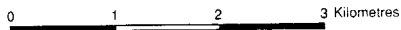

Scale 1:50 000

REFERENCE AREA



Major Road



Minor Road



Track

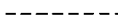

Park Boundary



Watercourse



Locality Plan

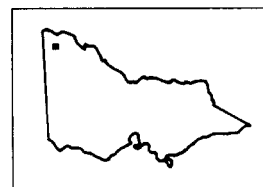

Map Number RA 30

**SCHEDULE 21**

The public land shown on the following plan, RA 31, to be known as the Purnya Reference Area;

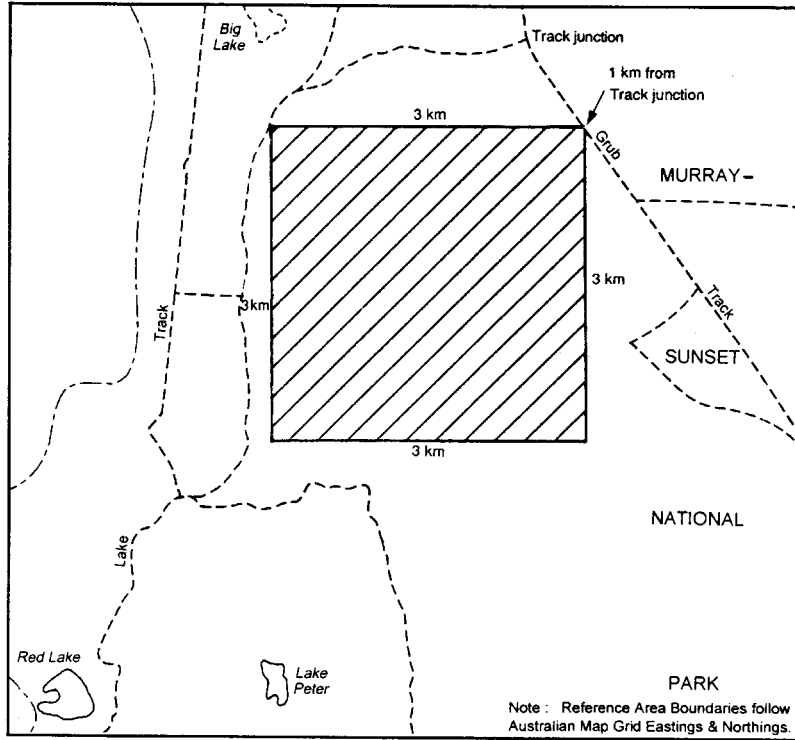





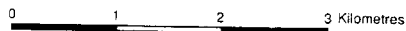

**PURNYA REFERENCE AREA**

Parish of Purnya



Scale 1:50 000

- REFERENCE AREA 
- Major Road 
- Minor Road 
- Track 
- Park Boundary 
- Watercourse 



Locality Plan

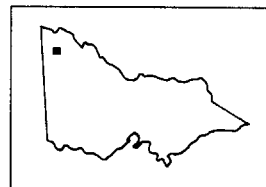

Map Number RA 31

**SCHEDULE 22**

The public land shown on the following plan, RA 39, to be known as the Rocket Lake Reference Area;

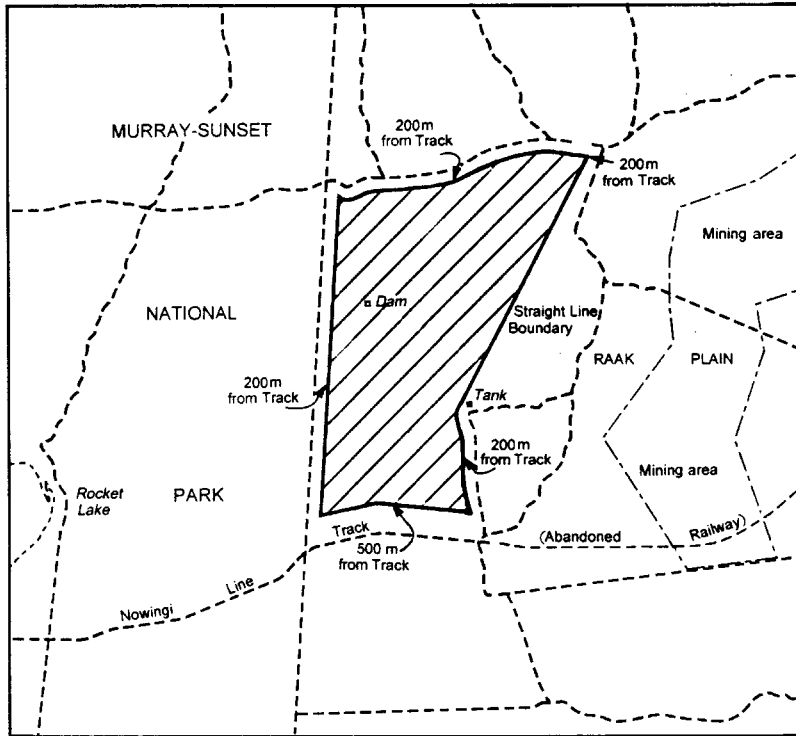

**ROCKET LAKE REFERENCE AREA**

Parish of Goonegul

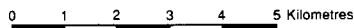

Scale 1:100 000

REFERENCE AREA



Major Road



Minor Road



Track

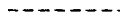

Park Boundary

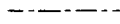

Watercourse



Locality Plan

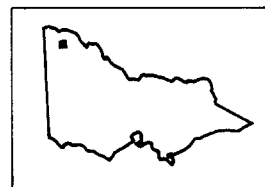

Map Number RA 39

**SCHEDULE 23**



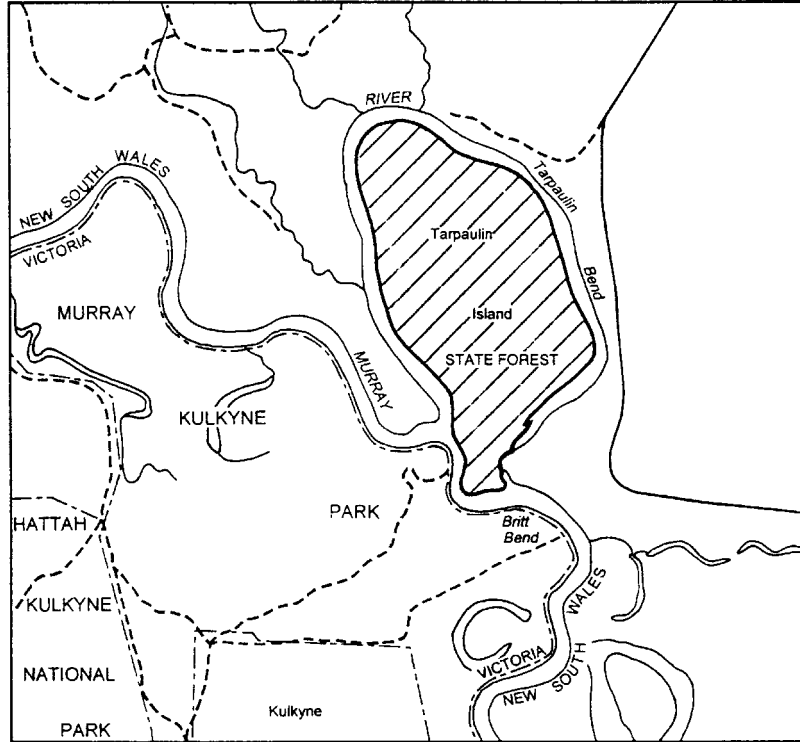

The public land shown on the following plan, RA 41, to be known as the Tarpaulin Island Reference Area;

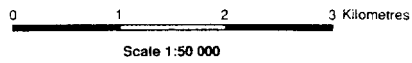

**TARPAULIN ISLAND REFERENCE AREA**

Parish of Kulkayne

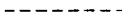
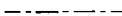

- REFERENCE AREA 
- Major Road 
- Minor Road 
- Track 
- Park Boundary 
- Watercourse 



Locality Plan

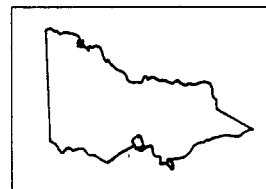

Map Number RA 41



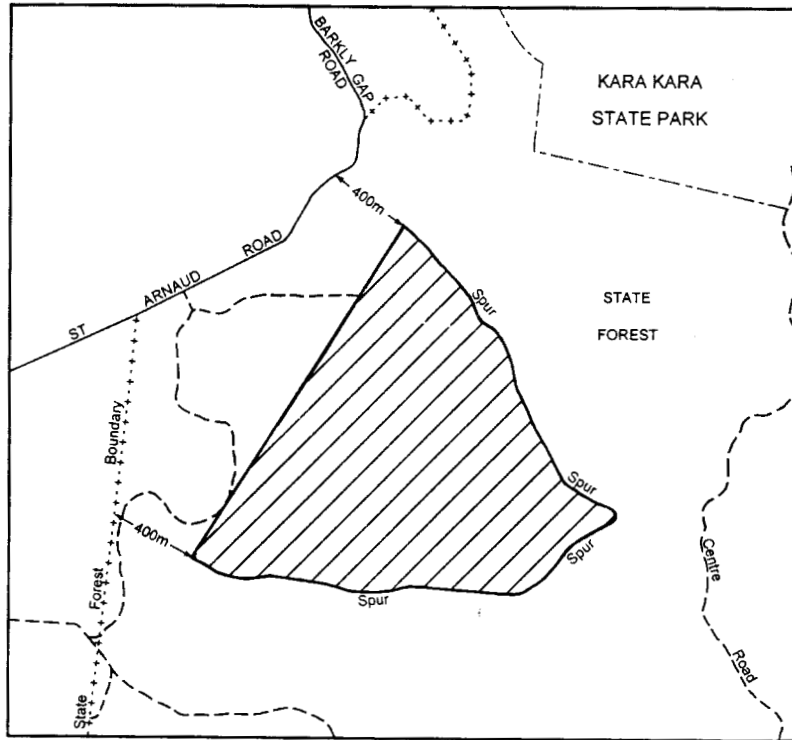

**SCHEDULE 24**

The public land shown on the following plan, RA 75, to be known as the Mount Separation Reference Area;

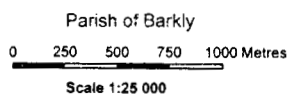

**MOUNT SEPARATION REFERENCE AREA**

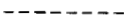

- REFERENCE AREA 
- Major Road 
- Minor Road 
- Track 
- Park Boundary 
- Watercourse 



Locality Plan

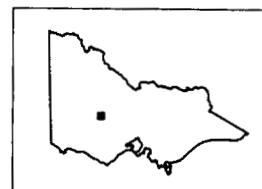

Map Number RA 75

**SCHEDULE 25**

The public land shown on the following plan, RA 80, to be known as the Rushworth Forest Reference Area;

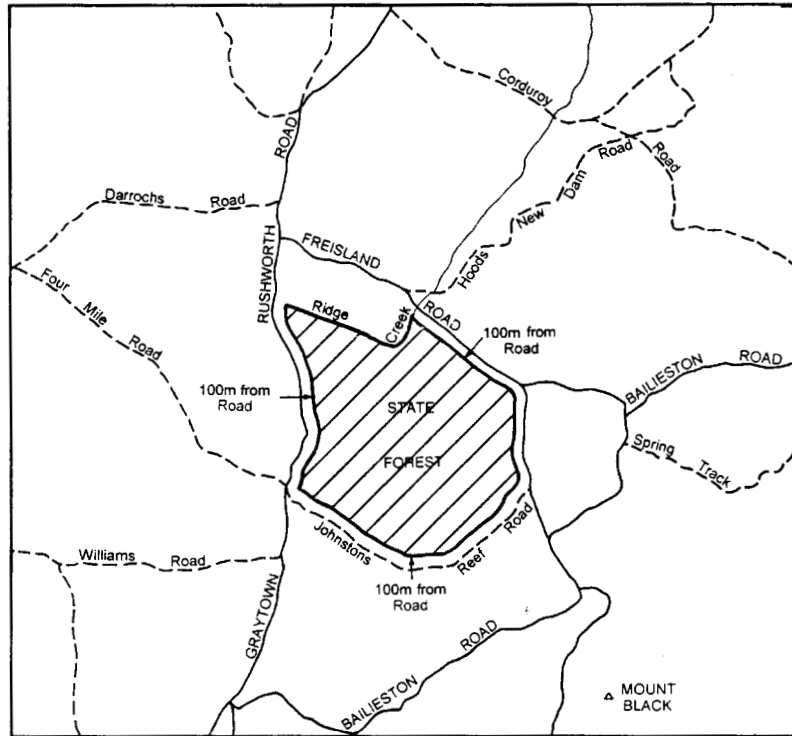





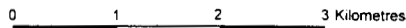

**RUSHWORTH FOREST REFERENCE AREA**

Parish of Wirrate

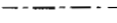

Scale 1:50 000

- REFERENCE AREA 
- Major Road 
- Minor Road 
- Track 
- Park Boundary 
- Watercourse 



Locality Plan

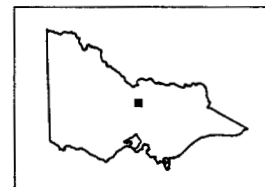

Map Number RA 80



**SCHEDULE 26**

The public land shown on the following plan, RA 29, to be known as the Chalka Creek Reference Area;

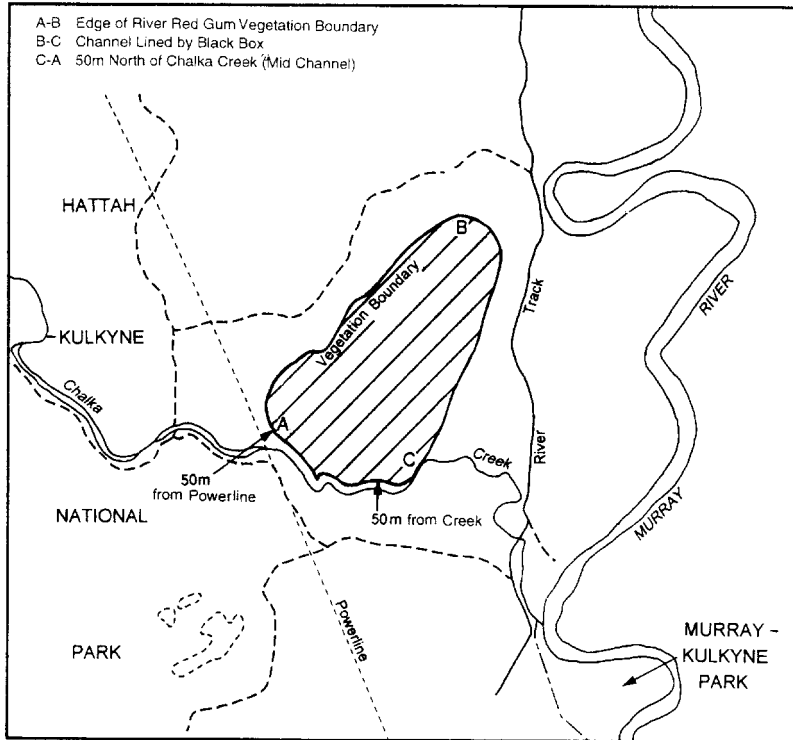





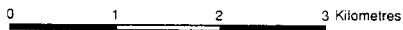

**CHALKA CREEK REFERENCE AREA**

Parish of Cantala



Scale 1:50 000

- REFERENCE AREA 
- Major Road 
- Minor Road 
- Track 
- Park Boundary 
- Watercourse 



Locality Plan

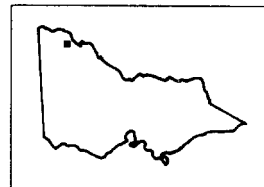

Map Number RA 29

**SCHEDULE 27**



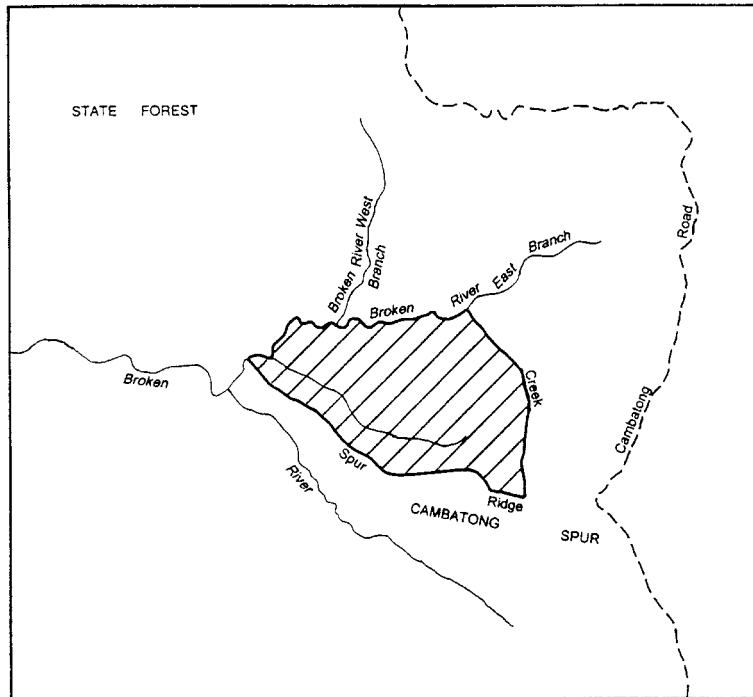



The public land shown on the following plan, RA 45, to be known as the Cambatong Reference Area;

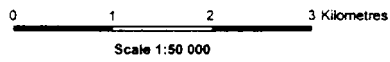

**CAMPATONG REFERENCE AREA**

Parish of Merrijig



- REFERENCE AREA 
- Major Road 
- Minor Road 
- Track 
- Park Boundary 
- Watercourse 



Locality Plan

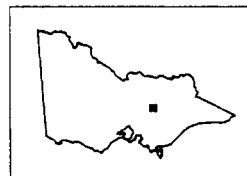

Map Number RA 45

**SCHEDULE 28**



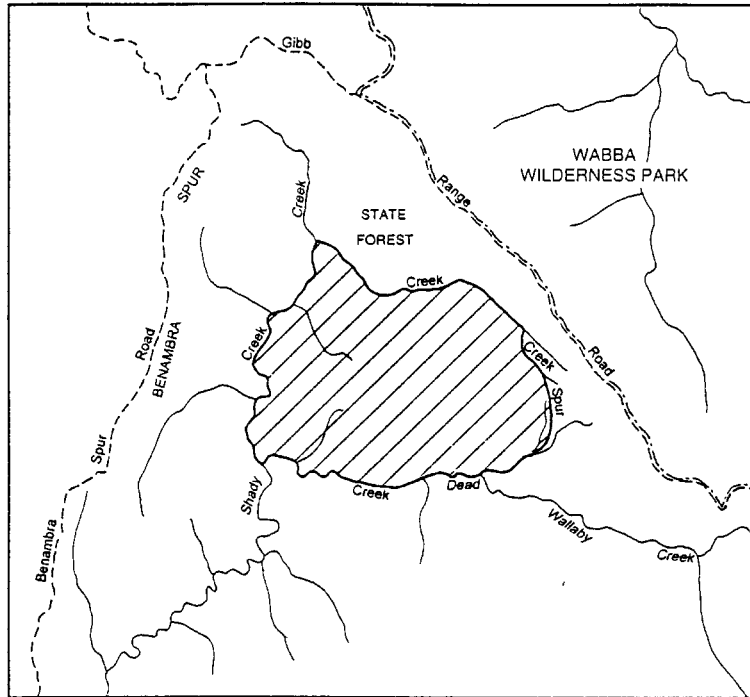

The public land shown on the following plan, RA 53, to be known as the Lightwood Reference Area;

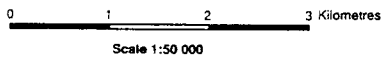

**LIGHTWOOD REFERENCE AREA**

Parish of Welumia

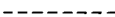

- REFERENCE AREA 
- Major Road 
- Minor Road 
- Track 
- Park Boundary 
- Watercourse 



Locality Plan

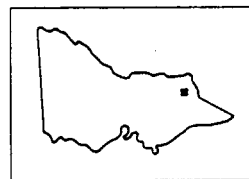

Map Number RA 53

Given under my hand and the seal of Victoria on 23 June 1998.

(L.S.)

**JAMES GOBBO**  
 Governor  
 By His Excellency's Command  
**MARIE TEHAN**  
 Minister for Conservation and  
 Land Management

**GOVERNMENT AND OUTER BUDGET SECTOR AGENCIES  
NOTICES**



**ROAD DISCONTINUANCE**

Notice is hereby given that the Pyrenees Shire Council at its ordinary meeting of 16 June, 1998 having considered submissions under Section 223 of the **Local Government Act 1989** have resolved in accordance with Clause 3 of the Schedule 10 of the **Local Government Act 1989** that the section of road as shown hatched in the plan hereunder be discontinued for public use and sold by private treaty to the adjoining owner.

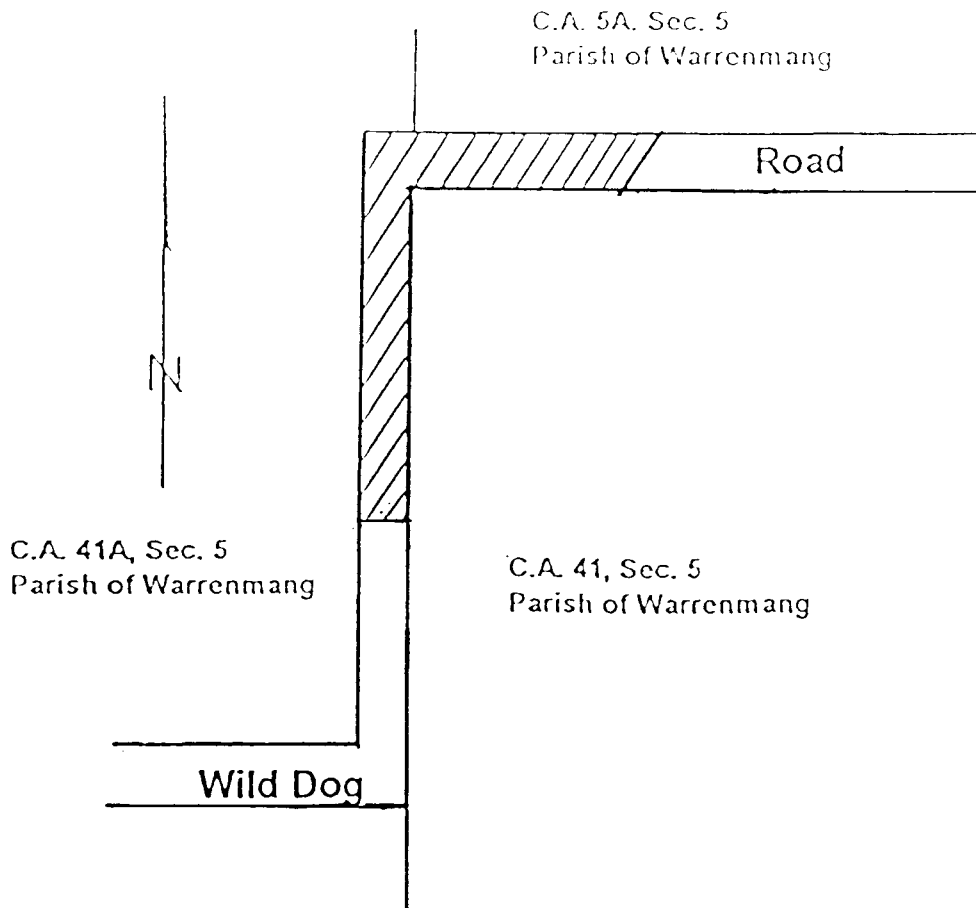

K. BRIAN KILEY  
Chief Executive Officer



ROAD DEVIATION

Notice is hereby given that the Pyrenees Shire Council at its ordinary meeting of 16 June, 1998 having considered submissions under Section 223 of the **Local Government Act 1989** have resolved in accordance with Clause 2 of Schedule 10 of the **Local Government Act 1989** that the section of road as shown hatched in the plan hereunder shall be opened as a road for public access.

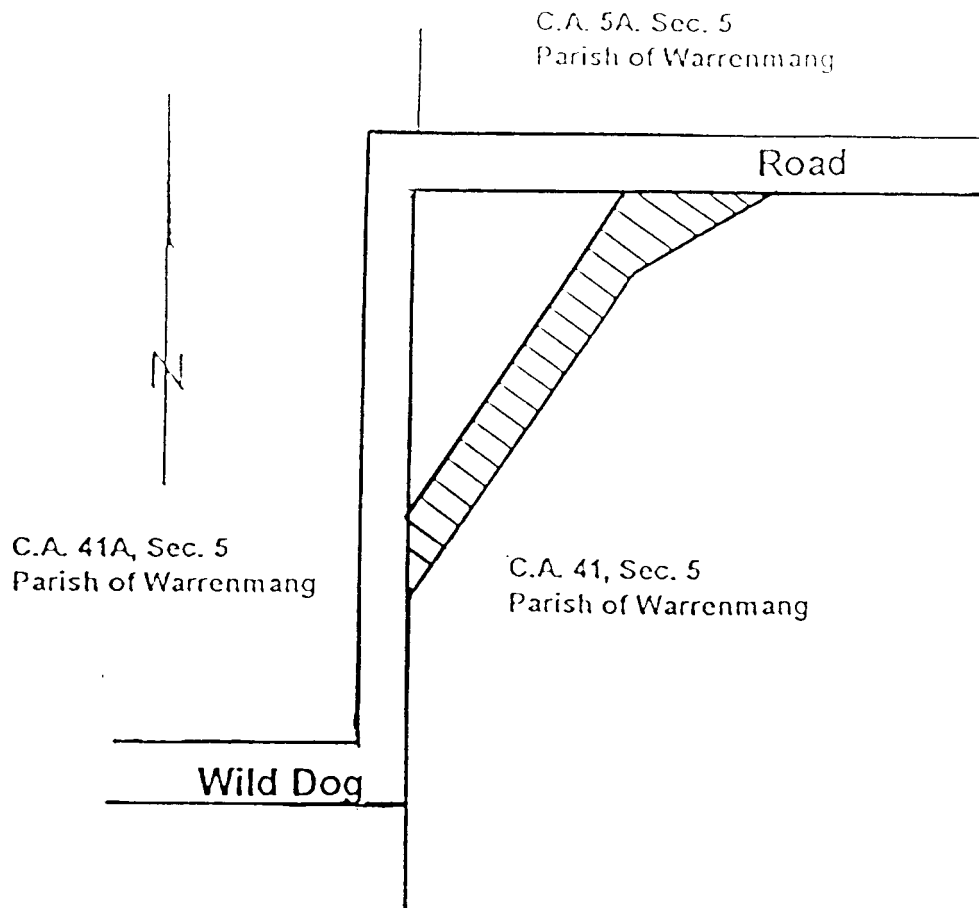

K. BRIAN KILEY  
Chief Executive Officer

BANYULE CITY COUNCIL  
Road Discontinuance

Pursuant to Section 206 and Schedule 10 Clause 3 of the **Local Government Act 1989**, Banyule City Council, at its ordinary meeting held on 15 June 1998, having formed the opinion that the section of "road" shown hatched on the plan below is not reasonably required as a "road" for public use, resolved to discontinue the section of "road" and sell the land by private treaty to the abutting owners subject to any right, power or interest held by Yarra Valley Water Ltd in connection with any drains, sewers and pipes under the control of that authority in or near the "road".

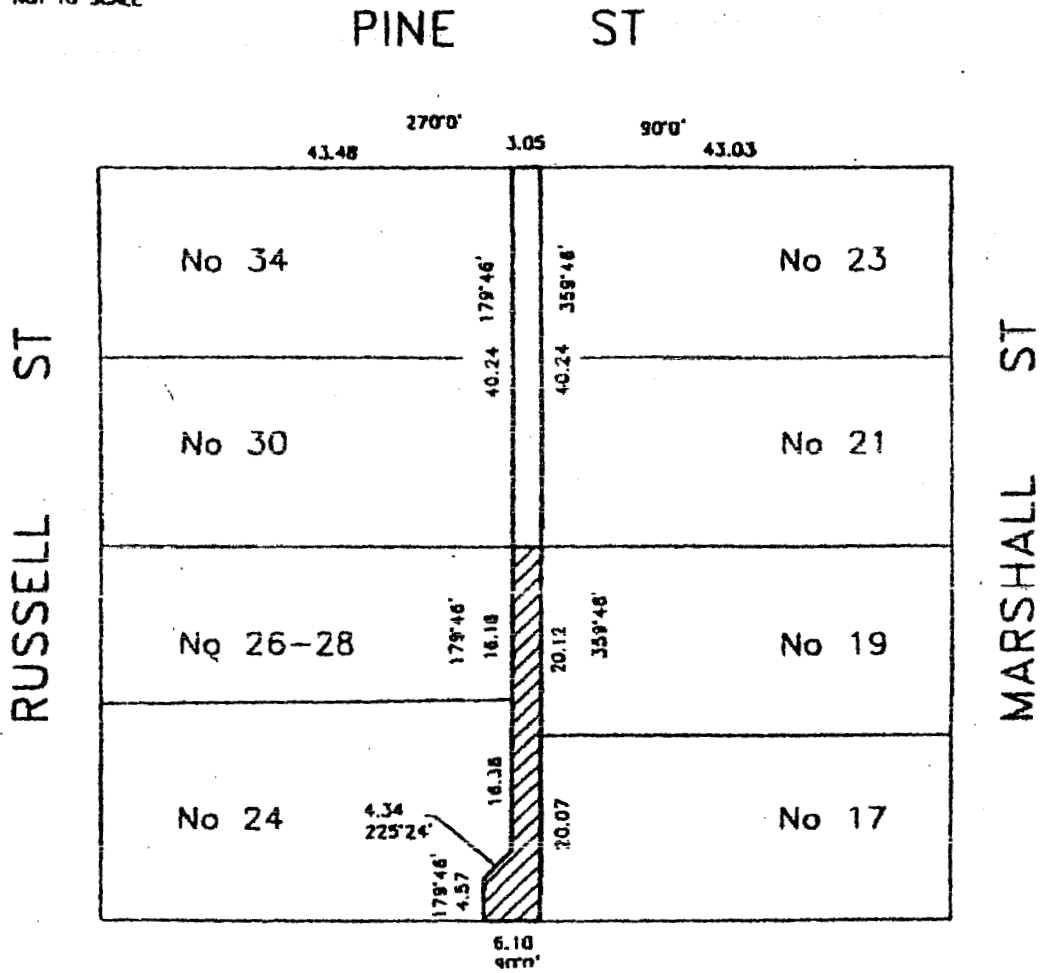

P. W. SODING  
Director City Development

BANYULE CITY COUNCIL  
Road Discontinuance

Pursuant to Section 206 and Schedule 10 Clause 3 of the **Local Government Act 1989**, Banyule City Council, at its ordinary meeting held on 15 June 1998, having formed the opinion that the section of "road" shown hatched on the plan below is not reasonably required as a "road" for public use, resolved to discontinue the section of "road" and retain the land for municipal purposes subject to any right, power or interest held by Melbourne Water Corporation in connection with any drains, sewers and pipes under the control of that authority in or near the "road".

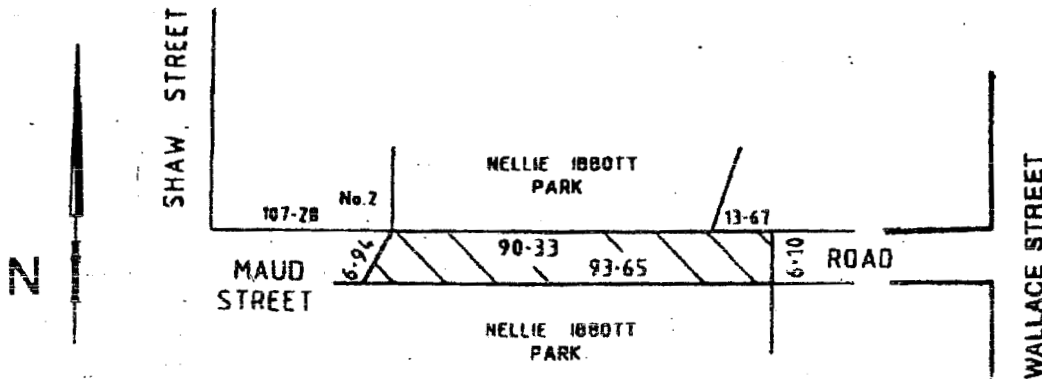

P. W. SODING  
Director City Development

COLAC OTWAY SHIRE COUNCIL  
Road Discontinuance

Pursuant to Section 206 and Schedule 10, Clause 3 of the **Local Government Act 1989**, the Colac Otway Shire Council declares as discontinued a portion of Newell Street, Colac as shown in cross hatching on the plan hereunder.

The road is to be discontinued subject to any right, power or interest held by Council or any other authority in connection with sewers, drains, pipes, wires or cables under the control of those authorities in or near the Road.

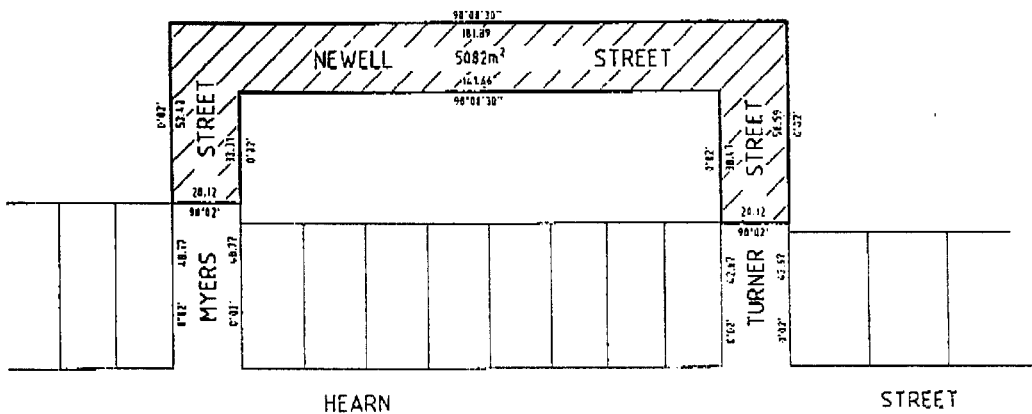

GLENN PATTERSON  
Chief Executive Officer

**CORANGAMITE SHIRE COUNCIL**  
**Road Discontinuance**  
**Vite Vite Road, Purra Purra**

Under Section 206 of the Schedule 10 Clause 3 of the **Local Government Act 1989** the Corangamite Shire Council at its December meeting held on 16 December 1997 formed the opinion that the road shown on the plan below is not reasonably required as a road for public use and resolved to discontinue the road and to sell the land to abutting owners.

**Appendix 10.1.9**

<b>PLAN OF SUBDIVISION</b> <small>Under Section 35 of the Subdivision Act 1988</small>	Stage No.	Plan Number PS 411519 Q
---	-----------	----------------------------

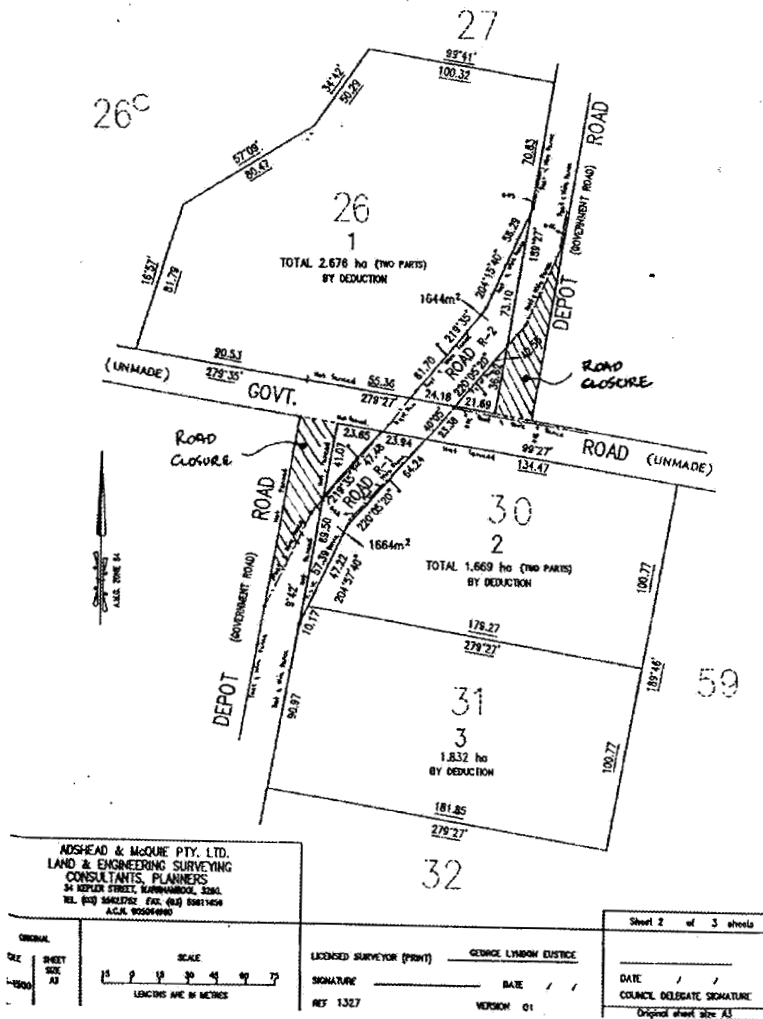

**PETER JOHNSTON**  
 Chief Executive Officer



CORANGAMITE SHIRE COUNCIL  
Road Discontinuance

Under Section 206 of the Schedule 10 Clause 3 of the **Local Government Act 1989**, the Corangamite Shire Council at its December meeting held on 16 December 1997 formed the opinion that the road shown on the plan below is not reasonably required as a road for public use and resolved to discontinue the road and to sell the land to abutting owners.

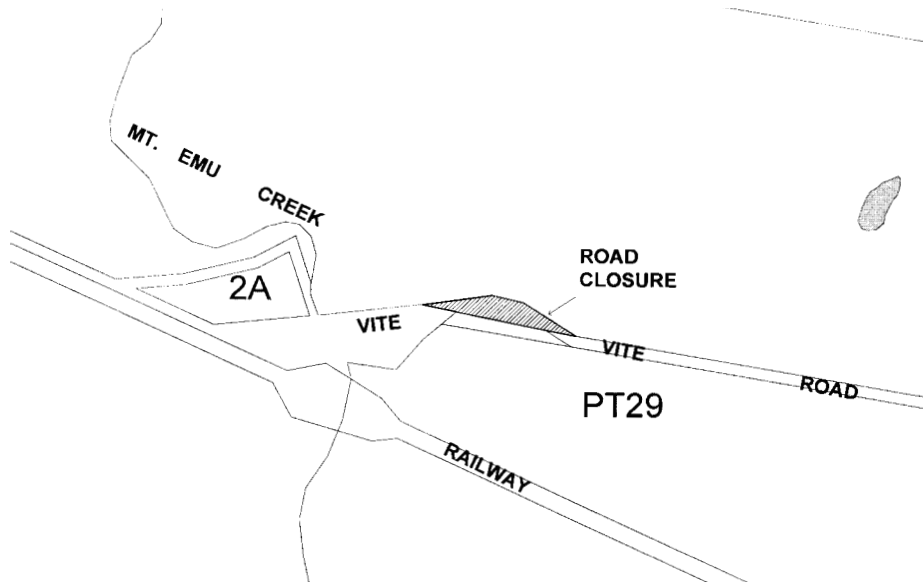

PETER JOHNSTON  
Chief Executive Officer



AMENDMENT TO LOCAL LAW NO. 2  
MUNICIPAL PLACES  
Consumption and Possession of Liquor on  
Roads

Notice is hereby given that Council at its Ordinary Meeting held on 16 June, 1998 resolved to amend the above Local Law.

The purpose of the Local Law is to:-

- (a) protect the lifestyle and amenity of the municipal district;
- (b) protect council and community facilities and assets; and
- (c) regulate behaviour, the time and places where liquor may be consumed and enable Council to declare smoke free areas.

The amendment to Section 10 of Part 4 - Liquor Control, refers to the change of area within the municipality that applies to the consumption and possession of liquor on roads

Any person affected by the amendment to the Local Law may make a submission to Council relating to the amendment under section 223 of the **Local Government Act 1989**.

Written submissions should be forwarded to the Rural City of Ararat, P.O. Box 246, Ararat 3377, marked Local Law Amendment. Only those submissions received by 3 p.m. 1 July, 1998 will be considered.

Any person may inspect a copy of the amendment to the above Local Law at the Municipal Offices, Vincent Street, Ararat, during office hours.

MR IAN COUPER  
Manager - Client Services

DAREBIN CITY COUNCIL  
Road Discontinuance

Under Section 206 and Schedule 10 Clause 3 of the **Local Government Act 1989**, the Darebin City Council at its Ordinary meeting held on 18 May 1998, formed the opinion that the road shown on the plan below is not reasonably required as a road for public use and resolved to discontinue the road and to sell the land from the road to abutting owners.

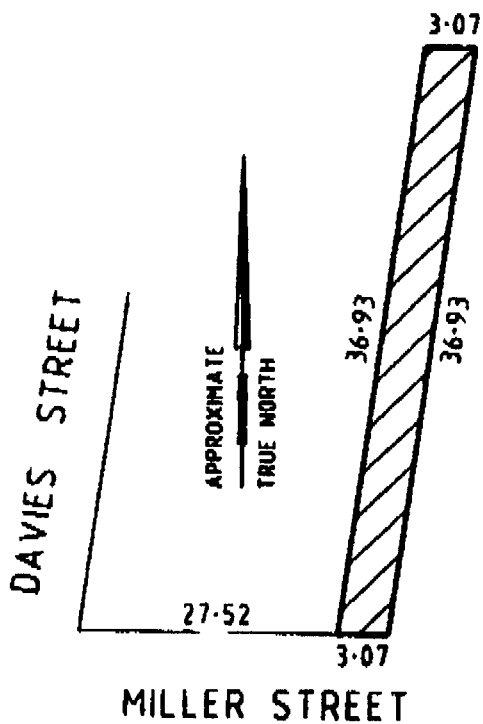

KELVIN SPILLER  
Chief Executive

MORELAND CITY COUNCIL  
Road Discontinuance

Under Section 206 and Schedule 10 Clause 3 of the **Local Government Act 1989**, the Moreland City Council at its Ordinary meeting held on 9 June 1998, formed the opinion that the roads shown on the plans below are not reasonably required as roads for public use and resolved to discontinue the roads and to retain the land for Municipal Purposes.

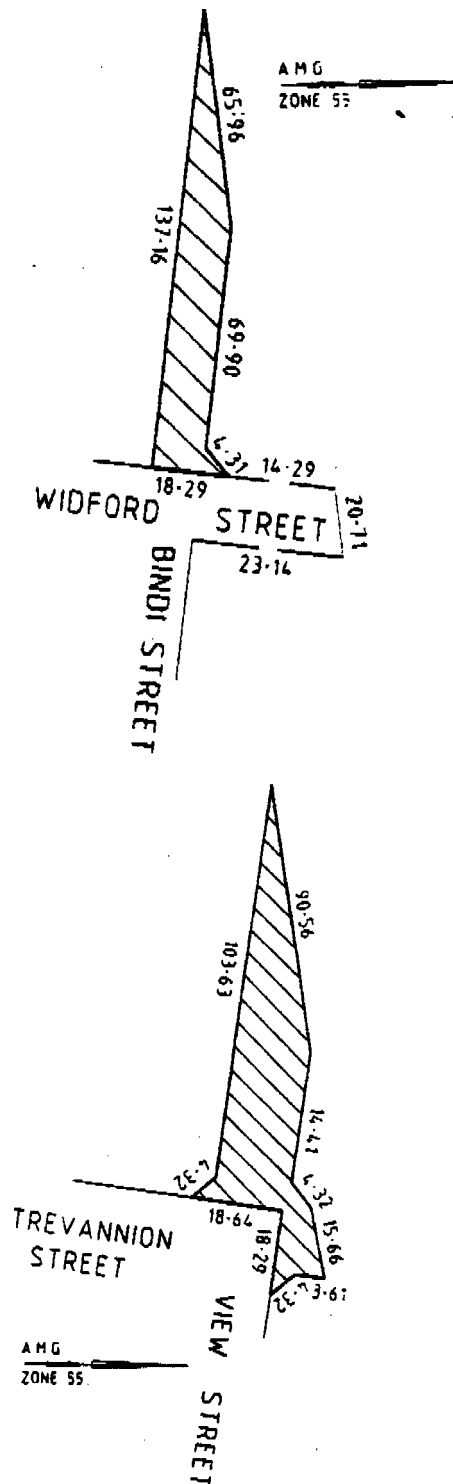

PETER JOHNSTONE  
Chief Executive

CARDINIA SHIRE COUNCIL  
Notice of Authorisation

The Cardinia Shire Council at its meeting on 18 May 1998 resolved, in accordance with Section 224(a) of the **Local Government Act 1989**, that any member of the Victoria Police Force may enforce the provisions of Council's General Local Law concerning the consumption of alcohol, the purpose of which is to prohibit, regulate and control the consumption of liquor and to protect against behaviour which is a nuisance or causes detriment to the amenity and environment of the municipality.

DON WELSH  
Chief Executive Officer



Yarra Valley  
Water

DECLARATION NOTICE  
360/298/0005

Yarra Valley is pleased to advise that sewerage services are now available as from 18/06/1998 to the Sewerage Areas detailed below.

**City of Maroondah**

**Serviced Area No. 6966:** Lot 1 to 16 Barnsdale Way, Lot 17 to 24 Loughies Track are all on PS 412706 and contains 24 lots.

**Serviced Area No. 6967:** Lot 2 to 4, 15 to 20, 41 to 46, 51 and 52 Woodlands Park Rise, Lot 5 to 14 Malinda Way, Lot 21 to 40 Mulduri Crescent, Lot 47 to 50 Bluegum Lane are all on PS 409114 and contains 51 lots.

**Serviced Area No. 6971:** Lot 1 to 12 McKerral Place, Lot 13 Yarra Road are all on PS 405490 and contains 13 lots.

**City of Moreland**

**Serviced Area No. 6970:** Lot 1 to 42, 68 to 100 Gowanbrae Drive, Lot 43 to 49, 67 Lanark Way, Lot 50 to 66 Primula Boulevard are all on PS 348744 and contains 100 lots.

**City of Whittlesea**

**Serviced Area No. 6965:** Lot 1059 to 1064, 1069 to 1077, 1089 to 1092, 1129 to 1130

Longwood Drive, Lot 1065 to 1068 Harvey Close, Lot 1078 to 1086 Trumpler Place, Lot 1087 to 1088 warne Grove, Lot 1093 to 1096 whitney Way, Lot 1097 to 1098, 1126 to 1128 Bradman Terrace, Lot 1131 to 1136, Lot 1170 to 1188, 1206 to 1207 Loxton Terrace, Lot 1204 to 1205 Woodfull Way are all on PS 405433.

Lot 1099 to 1125 Bradman Terrace, Lot 1137 to 1169, 1189 to 1195, 1219 to 1220 Loxton Terrace, Lot 1196 to 1203 Woodfull Way, Lot 1208 to 1218 Benaud Place are all on PS 412484 and contains 163 lots.

**Serviced Area No. 6972:** Lot 78 to 85, 93 to 96, 109 to 116 Bluebell Drive, Lot 86 to 92 Columbine Court, Lot 97 to 108 Larkspur Close are all on PS 406734 and contains 38 lots.

**Shire of Yarra Ranges**

**Serviced Area No. 6968:** Lot 229 to 245 The Gateway, Lot 246 to 266, 279 to 282, 295 to 301 Chester Street, Lot 267 to 278 Revenue Place, Lot 283 to 294 Banker Court are all on PS 413035 and contains 73 lots.

**Serviced Area No. 6969:** Lot 418, 451 to 454 Billanook Way, Lot 419 to 421, 448 to 450 Rosewood place are all on PS 412271 and contains 11 lots.

Further particulars may be obtained from Yarra Valley Water's Declarations Officer, Lou Vitelli, telephone 9872 2592.

YARRA VALLEY WATER LIMITED  
ACN 066 902 501



Yarra Valley  
Water

WATER PROCLAMATION NOTICE  
544/298/0005

Yarra Valley is pleased to advise that water services are now available as from 18/06/1998 to the areas detailed below.

**City of Hume**

**801/237/1869**

Northcorp Boulevard, from 67 metres north west corner of Lot 41 further westwards 312 metres.

**530/244/0279**

Maclaren Court, the whole court.

**City of Manningham**

530/243/2882

Elizabeth Court, the whole court.

530/243/9260

Omar Street, the whole street.

**City of Maroondah**

530/249/9824

Barnsdale Way, the whole way.

Loughies Way, the whole way.

530/258/0470

McKerral Place, the whole place.

530/258/1142

Mulduri Crescent, the whole crescent.

Malinda Way, the whole way.

Bluegum Lane, the whole lane.

Woodland Park Rise, the whole rise.

Lawson Court, the whole court.

**City of Monash**

530/241/9337

The Grove, from south west corner of Lot 36 further northwards 106 metres and then eastwards 32 metres.

530/241/9338

The Grove, from north west corner of Lot 37 further southwards 32 metres and then eastwards 55 metres.

Spring Rise, the whole rise.

Timber Lane, from south west corner of Lot 14 further eastwards 301 metres and then southwards 105 metres.

530/009/0002

Clarke Place, the whole place.

Yvette Court, the whole court.

**City of Moreland**

801/213/1171

Harrison Street, from Donald Street further southwards 226 metres.

Carson Way, from Harrison Street further westwards 29 metres.

Franklins Rise, from Harrison Street further westwards 31 metres.

530/237/9554

Gowanbrae Drive, the whole drive.

Primula Boulevard, the whole boulevard.

Lanark Way, the whole way.

Bluebell Crescent, from south west corner of Lot 30 further south east 55 metres.

**City of Whittlesea**

530/239/0805 and 530/239/0806

Bluebell Drive, the whole drive.

Columbine Court, the whole court.

Larkspur Close, the whole close.

530/239/2662 and 530/239/2667

Trumper Place, the whole place.

Warne Grove, the whole place.

Whitney Way, the whole way.

Longwood Drive, the whole drive.

Loxton Terrace, the whole terrace.

Bradman Terrace, the whole terrace.

Harvey Close, the whole close.

Woofull Way, the whole way.

Benaud Place, the whole place.

Ponsford Place, the whole place.

**Shire of Yarra Ranges**

530/260/0919

Billanook Way, from north east corner of Lot 454 further south east 56 metres.

Rosewood Place, from north west corner of Lot 421 further north east 56 metres.

530/260/0920

Chatswood Grove, from north east corner of Lot 275 further westwards 30 metres and then southwards 101 metres.

530/260/9267

The Gateway, from south west corner of Lot 239 further westwards 163 metres.

Chester Street, the whole street.

Banker Court, the whole court.

Revenue Place, the whole place.

Further particulars can be obtained from Yarra Valley Water's Proclamations Officer, Lou Vitelli, telephone 9872 2592.

YARRA VALLEY WATER LIMITED  
ACN 066 902 501

NORTH EAST REGION WATER  
AUTHORITY

Declared Sewerage Areas Bundalong

Notice is hereby given pursuant to Section 144 of the **Water Act 1989** that properties in the Bundalong Township area are declared as serviced for sewerage on and from 13 July 1998. The properties declared as serviced by sewer are in the following areas: Lot 1 LP68013, Lot 2 LP 68013, Lot 1 LP94535, Lot 2 LP94535 & Lot 1 Pt CA 11A Austin Road; 2,

4, 6, 8-31, 33, 35, 37, 39, 41, 43 & 45 Bailey Street; 1-24 Francis Elliot Court; 1, 3, 5, 7, 9 & 11 Goughs Lane; 1-70 Graham Avenue; 2, 4, 6, 8, 10, 12, 14, 16, 18, 20, 22, 24, 26, 28, 30, 32, 34, 36, 38 & Lots 1-3 Ligar Street; Lots 1-4 Pasley Avenue; 1-33 Phalaris Lane; and 1-40 William Street.

The plan of the declared area is available for inspection at the office of North East Region Water Authority, Level 3, Hovell Street, Wodonga, Victoria 3690 between 9.00 a.m. and 5.00 p.m. Monday to Friday.

J. B. O'BRIEN

---

**Planning and Environment Act 1987**

**MONASH PLANNING SCHEME**

Notice of Amendment

Amendment L37

The City of Monash has prepared Amendment L37 to the Monash Planning Scheme.

The Amendment proposes to rezone land at 171-175 Jells Road, Wheelers Hill to Residential "C". The land is currently "Reserved Land Local Government: Existing" under the Monash Planning Scheme.

Council has resolved to sell the property and Residential "C" will be consistent with the intended use and surrounding residential properties.

A copy of the Amendment can be inspected during office hours free of charge at City of Monash, Civic Centre, 293 Springvale Road, Glen Waverley or the Department of Infrastructure, Upper Plaza, Nauru House, 80 Collins Street, Melbourne.

DAVID CONRAN  
Chief Executive Officer

---

Creditors, next-of-kin and others having claims against the estate of any of the undermentioned deceased persons are required to send particulars of their claims to State Trustees Limited, A.C.N. 064 593 148, 168 Exhibition Street, Melbourne, Victoria 3000, the personal representative, on or before 25 August 1998 after which date State Trustees Limited may convey or distribute the assets having regard only to the claims of which State Trustees Limited then has notice.

BRUNELL Lionel Gregory, late of 9 George Street, North Melbourne, pensioner, who died 26 January, 1998.

CASTERSEN Frances Catherine, late of Andrina Private Nursing Home, 360 New Street, Brighton, home duties, who died 17 August, 1997.

DOWNES Hazel Olive, late of Vermont Private Nursing Home, Canterbury Road, Vermont, married woman, who died 29 March, 1998.

KEATING John Deakin, late of Rushall Crescent, North Fitzroy, retired, who died 23 April, 1998.

O'NEILL Monica, late of Southern Cross Homes, 74 Victoria Street, Hastings, retired, who died 12 July, 1997.

SMART Winifred Anne, late of 54 Western Beach, Geelong, widow, who died 13 April, 1998.

STOWELL Wallace, late of 2661 Launching Place Road, Gembrook, technician, who died 25 July, 1996.

WATTERS Joan Elizabeth, late of 126 Maidstone Street, Altona, pensioner, who died 11 April, 1998.

WILD Margaret Josephine, late of 12 Queens Avenue, Oakleigh, widow, who died 10 February, 1998.

Dated at Melbourne 16 June, 1998.

CATHY VANDERFEEN  
Manager, Estate Management  
State Trustees Limited

---

Creditors, next-of-kin and others having claims against the following estates:

RACHEL MAREE BIRD, late of 4 Allandale Drive, Deer Park, Victoria, pensioner, deceased intestate, who died on 11 May 1998.

WILLIAM JOSEPH ROBERTSON, late of 17 Birdwood Street, Box Hill South, Victoria, retired, deceased, who died on 12 May 1998.

ALBERT SANOVSKI, late of 21-25 Inverness Street, Clarinda, Victoria, pensioner, deceased intestate, who died on 17 April 1998.

Creditors, next-of-kin and others having claims against the abovementioned estates are required pursuant to Section 33 of the **State Trustees Act 1958** to send particulars of their claims against the abovementioned estates to State Trustees Limited, 168 Exhibition Street, Melbourne, Victoria, on or before 25 August 1998 after which date State Trustees Limited, A.C.N. 064 593 148, may convey or distribute the assets of the abovementioned estates having regard only to the claims of which it then has notice.

---

EXEMPTION FROM NOTIFICATION OF  
VACANCY UNDER SECTION 29(2) OF  
THE PUBLIC SECTOR MANAGEMENT  
ACT 1992

Position number: 130130, Accountant, VPS-3, Accounting Operations, Northern Irrigation Region Tatura, Department of Natural Resources and Environment.

*Reason for exemption*

The vacancy or a similar vacancy has been advertised within the last 3 months without attracting a qualified applicant and/or the vacancy is in an area with a history of recruitment difficulties, and the proposed appointee (who may or may not be a staff member) is assessed as clearly meeting all of the requirements of the position.

MICHAEL TAYLOR  
Secretary,  
Department of Natural Resources  
and Environment

---

EXEMPTION FROM NOTIFICATION OF  
VACANCY UNDER SECTION 29(2) OF  
THE PUBLIC SECTOR MANAGEMENT  
ACT 1992

Position number: NRE139623, Manager Petroleum Drilling Engineering, VPS-5, Department of Natural Resources and Environment.

*Reason for exemption*

The vacancy has duties and qualifications requirements that are of a specialised nature peculiar to the Department and the proposed appointee is a staff member considered to be the

only staff member possessing the specialised qualifications.

MICHAEL TAYLOR  
Secretary,  
Department of Natural Resources  
and Environment

---

EXEMPTION FROM NOTIFICATION OF  
VACANCY UNDER SECTION 29(2) OF  
THE PUBLIC SECTOR MANAGEMENT  
ACT 1992

Position Number 35/01/4077/2, Manager, Financial Services, Class VPS-5, Building Services Agency, Department of Infrastructure.

*Reason for exemption*

The position has been reclassified to recognise a demonstrated and significant shift in work value in a specialised area of work, the incumbent is an officer who is recognised as satisfactorily discharging all of the requirements of the position and the Department Head considers that it is unlikely that advertising the vacancy would attract more suitable candidates.

SUE JAQUINOT  
Deputy Secretary,  
Department of Infrastructure

---

EXEMPTION FROM NOTIFICATION OF  
VACANCY UNDER SECTION 29(2) OF  
THE PUBLIC SECTOR MANAGEMENT  
ACT 1992

Position Number 35/01/4931/4, Team Leader, Modular Buildings, Class VPS-3, Building Services Agency, Department of Infrastructure.

*Reason for exemption*

The position has been reclassified to recognise a demonstrated and significant shift in work value in a specialised area of work, the incumbent is an officer who is recognised as satisfactorily discharging all of the requirements of the position and the Department Head considers that it is unlikely that advertising the vacancy would attract more suitable candidates.

SUE JAQUINOT  
Deputy Secretary,  
Department of Infrastructure

---

EXEMPTION FROM NOTIFICATION OF  
VACANCY UNDER SECTION 29(2) OF  
THE PUBLIC SECTOR MANAGEMENT  
ACT 1992

Position Number: OFFSUPP 938, VPS-1,  
Central Property Management Facility, Supply  
Division, Business Management Department.

*Reason for exemption*

The proposed appointee has been merit  
selected for a period of more than 12 months in  
the position of Storekeeper, Central Property  
Management Facility, Supply Division. The  
above position has subsequently become  
vacant.

M. N. (NEIL) COMRIE  
Chief Commissioner of Police

---

EXEMPTION FROM NOTIFICATION OF  
VACANCY UNDER SECTION 29(2) OF  
THE PUBLIC SECTOR MANAGEMENT  
ACT 1992

Position Numbers: TECHSPEC 198 and  
199, VPS-3, Radio Network Services,  
Technology Services Division, Business  
Management Department.

Position Number: TECHSPEC 197, VPS-3,  
Radio Electronic Services, Technology Services  
Division, Business Management Department.

*Reason for exemptions*

The positions have been reclassified to  
recognise a demonstrated and significant shift in  
work value in a specialised area of work and the  
incumbents are officers who are recognised as  
satisfactorily discharging all the requirements  
of the positions and the Department Head  
considers that it is unlikely that advertising the  
positions would attract more suitable  
candidates.

M. N. (NEIL) COMRIE  
Chief Commissioner of Police

---

EXEMPTION FROM NOTIFICATION OF  
VACANCY UNDER SECTION 29(2) OF  
THE PUBLIC SECTOR MANAGEMENT  
ACT 1992

Position Number: DSD002695, Employee  
Relations Adviser, Employee Relations Policy  
Branch, VPS-2, Department of State  
Development.

*Reason for exemption*

The position has duties and qualifications of  
a specialised nature particular to the  
Department and the proposed appointee is the  
only staff member considered to possess the  
specialised qualifications.

RIK HART  
Secretary,  
Department of State Development

---

EXEMPTION FROM NOTIFICATION OF  
VACANCY UNDER SECTION 29(2) OF  
THE PUBLIC SECTOR MANAGEMENT  
ACT 1992

Position Number: DSD005718, Employee  
Relations Adviser, Employee Relations Policy  
Branch, VPS-3, Department of State  
Development.

*Reason for exemption*

The position has duties and qualifications of  
a specialised nature particular to the  
Department and the proposed appointee is the  
only staff member considered to possess the  
specialised qualifications.

RIK HART  
Secretary,  
Department of State Development

---

EXEMPTION FROM NOTIFICATION OF  
VACANCY UNDER SECTION 29(2) OF  
THE PUBLIC SECTOR MANAGEMENT  
ACT 1992

Position Number: 350128187, Portfolio  
Services Division, Department of Human  
Services.

*Reasons for exemption*

The position has identical duties and  
qualifications to a position that was recently  
advertised and the person applied for the  
vacancy and was assessed as meeting the  
requirements of the position.

W. J. McCANN  
Secretary,  
Department of Human Services

---

EXEMPTION  
Application No. 45 of 1998

The Anti-Discrimination Tribunal  
constituted by the President pursuant to Section  
182 of the **Equal Opportunity Act 1995** (the  
Act), has considered an application pursuant to

Section 83 of the Act by Fastleigh Workforce Inc. trading as Southern Youth Employment. The application for exemption is to enable the applicant to advertise for and provide pre-employment services, placement, and post placement support to unemployed persons aged 15-39 years.

Upon reading the material tendered in support of this application the Tribunal is satisfied that it is appropriate to grant an exemption from Sections 13, 42, 100 and 195 of the Act to enable the applicant to advertise for and provide pre-employment services, placement, and post placement support to unemployed persons aged 15-39 years.

In granting this exemption the Tribunal noted:

- Southern Youth Employment is contracted by the Department of State Development to assist people aged 15-39 years into jobs.
- According to market statistics, youths aged 15 to 24 have less experience in the labour force and need specialised assistance in their job seeking skills.
- The 25-39 age group has been assessed by the Department of State Development as requiring some assistance. This group is often unskilled and on the long term unemployed list due to being unable to secure any post school educational qualifications, having few specialised skills to offer the market place in a competitive job seeker climate. The group also includes mothers moving back into the work place.

The Tribunal grants an exemption from the operation of Sections 13, 42, 100 and 195 of the **Equal Opportunity Act 1995**, to enable the applicant to advertise for and provide pre-employment services, placement, and post placement support to unemployed persons aged 15-39 years. This exemption is to remain in force from the day on which notice of the exemption is published in the Government Gazette until 24 June 2001.

CATE McKENZIE  
President

#### EXEMPTION

Application No. 54 of 1998

The Anti-Discrimination Tribunal constituted by the President pursuant to Section 182 of the **Equal Opportunity Act 1995** ("the Act") has considered an application pursuant to Section 83 of the Act by Frances Carlisle Pty Ltd. The application for exemption is to enable the applicant to provide education programs for women only at a centre called "The Nagle Education for Women".

Upon reading the material tendered in support of this application the Tribunal is satisfied that it is appropriate to grant an exemption from Sections 37, 42, 100 and 195 of the Act to provide education programs for women only at a centre called "The Nagle Education for Women".

In granting this exemption the Tribunal noted:

- The program provides an education centre for women on low incomes who lack the opportunity and the finances to seek further education.
- The project is limited to women because it is seen that they have particular needs, not only in education of the general type, but also in the areas of parenting and personal development to cope with the deprivation of any support from a partner or family.
- The program offers women an opportunity to discover and develop their individual talents in an environment that promotes confidence, independence and personal fulfilment.
- Most of the people wishing to attend the program are single mothers or women who are alone in bringing up children.

The Tribunal grants an exemption from the operation of Sections 37, 42, 100 and 195 of the **Equal Opportunity Act 1995** to enable the applicant to provide education programs for women only at a centre called "The Nagle Education for Women". This exemption is to remain in force from the day on which notice of the exemption is published in the Government Gazette until 24 June 2001.

CATE McKENZIE  
President



## EXEMPTION

Application No. 55 of 1998

The Anti-Discrimination Tribunal constituted by the President pursuant to Section 182 of the **Equal Opportunity Act 1995** ("the Act") has considered an application pursuant to Section 83 of the Act by Council for Single Mothers and Their Children Inc. The application for exemption is to enable the applicant to employ single mothers in its work with single mothers and their children.

Upon reading the material tendered in support of this application the Tribunal is satisfied that it is appropriate to grant an exemption from Sections 37, 42, 100 and 195 of the Act to enable the applicant to employ single mothers in its work with single mothers and their children.

In granting this exemption the Tribunal noted:

- The Council of Single Mothers and Their Children Inc. is a self-help group, run by and for single mothers and their children.
- Single mothers can offer a better service to other single mothers by virtue of their common experience. It is widely recognised that peer support is one of the most effective support mechanisms. Single mothers can empathise with and understand the issues that their peers experience more readily than women who are not single mothers.
- It is one of the cornerstones of self-help groups that their workers and/or volunteers come from the same group to whom they are targeting their services because of the enhanced ability they have to relate to and identify with service users.

The Tribunal grants an exemption from the operation of Sections 37, 42, 100 and 195 of the **Equal Opportunity Act 1995**, to enable the applicant to employ single mothers in its work with single mothers and their children. This exemption is to remain in force from the day on which notice of the exemption is published in the Government Gazette until 24 June 2001.

CATE McKENZIE  
President

## EXEMPTION

Application No. 57 of 1998

The Anti-Discrimination Tribunal constituted by the President pursuant to Section 182 of the **Equal Opportunity Act 1995** ("the Act") has considered an application pursuant to Section 83 of the Act by Western Metropolitan Youth Employment Project Inc. trading as Youth Employment Service Western Region ("YES West"). The application for exemption is to enable the applicant to advertise for and provide pre-employment services, placement, and post placement support to unemployed persons aged 15-39 years.

Upon reading the material tendered in support of this application the Tribunal is satisfied that it is appropriate to grant an exemption from Sections 13, 42, 100 and 195 of the Act to enable the applicant to advertise for and provide pre-employment services, placement, and post placement support to unemployed persons aged 15-39 years.

In granting this exemption the Tribunal noted:

- Western Metropolitan Youth Employment Project Inc. is an Incorporated Association which has received continuous funding over three years, from the Department of State Development's ("DSD") Community Business Employment Project.
- DSD also funds projects within the Outer Western Regions which specifically work with the "mature" category of unemployed people - aged 40 years and over.
- According to market statistics, youths aged 15 to 24 have less experience in the labour force and need specialised assistance in their job seeking skills.
- The 25-39 years group has been assessed by the Department of State Development as requiring some assistance. This group is often unskilled and on the long term unemployed list due to being unable to secure any post school educational qualifications, having few specialised skills to offer the market place in a competitive job seeker climate. The group also includes mothers moving back into the work place

The Tribunal grants an exemption from the

operation of Sections 13, 42, 100 and 195 of the **Equal Opportunity Act 1995**, to enable the applicant to advertise for and provide pre-employment services, placement, and post placement support to unemployed persons aged 15-39 years. This exemption is to remain in force from the day on which notice of the exemption is published in the Government Gazette until 24 June 2001.

CATE McKENZIE  
President

Department of Treasury and Finance  
SALE OF CROWN LAND  
BY PUBLIC AUCTION

**Auction Date:** Saturday 1 August 1998 at 11.00 a.m., on site.

**Property Address:** Mill Road, Archies Creek.

**Crown Description:** Allotment 90F, Parish of Woolamai.

**Area:** 2.8270 hectares.

**Terms of Sale:** 10% deposit - balance 60 days.

**Co-ordinating Officer:** Paul Kingston, Department of Natural Resources & Environment, Port Phillip Region, 30 Prospect Street, Box Hill 3128.

**Selling Agent:** Alex Scott & Staff P/L, 99 Graham Street, Wonthaggi. Telephone: (03) 5672 1911.

ROGER M. HALLAM  
Minister for Finance

Department of Treasury and Finance  
SALE OF CROWN LAND  
BY PUBLIC AUCTION

**Reference:** P040339.

**Auction Date:** Thursday 20 August 1998 at 2.30 p.m., on site.

**Property Address:** Government Road, Panmure.

**Crown Description:** Allotment 12, Section 4A, Township of Panmure.

**Area:** 1.214 hectares.

**Terms of Sale:** 10% deposit - balance 60 days.

**Co-ordinating Officer:** Stewart Beaton, Land Sales Officer, Department of Natural Resources and Environment, 17 Thompson Street, Hamilton 3300.

**Selling Agent:** Mr Roger Cussen, Northeast Cussen & Steere Real Estate P/L, 128 Lava Street, Warrnambool 3280. Telephone: (03) 5561 4444.

ROGER M. HALLAM  
Minister for Finance

### Racing Act 1958

#### APPOINTMENT OF RACING APPEALS TRIBUNAL ADVISORY PANEL MEMBERS

The following persons are appointed, under section 831 of the **Racing Act 1958**, as members of the Racing Appeals Tribunal Thoroughbred Racing Advisory Panel for the period 15 June 1998 to 2 January 2001.

Anne Murray Carlyon, Shelly Florence Hancox, Joanne McDonald Spears.

Dated 15 June 1998.

TOM REYNOLDS, MP  
Minister for Sport

### Land Acquisition and Compensation Act 1986

#### Transport Act 1983

##### NOTICE OF ACQUISITION

Compulsory Acquisition of Interest in Land

The Roads Corporation declares that by this notice it acquires the following interests in the land described as part of common property on Strata Plan No. 7617, comprising 21 square metres and shown as parcel 12 on Roads Corporation Survey Plan No. 19352.

**Interests Acquired:** That of Mr V. Huynh, Mr R. & Mrs M. O'Meara, Mr I. & Mrs S. Georgiev, Mr J. & Mrs J. Cohen, Mr R. & Mrs M. Short, Mr B. Tranis, Mr M. D. Atkinson, Mr J. & Mrs P. Cheng, Mrs H. S. H. Chung and Mrs G. Growcott (nee Gray) as registered proprietors.

The survey plan referred to in this notice may be viewed at the office of Property Services Department, Roads Corporation, 60 Denmark Street, Kew.

Published with the authority of the Roads Corporation and the Minister for Roads and Ports.

T. H. HOLDEN  
Manager Property Services  
Roads Corporation

**Private Agents Act 1966****NOTICE OF RECEIPT OF APPLICATIONS FOR LICENCES UNDER THE PROVISIONS OF THE PRIVATE AGENTS ACT 1966**

I, the undersigned, being the Deputy Registrar of the Melbourne Magistrates' Court hereby give notice that applications, as under have been lodged for hearing by the said Court on the date specified.

Any person desiring to object to any such application must:

- (a) lodge with me a notice in the prescribed form of his objection and of the grounds thereof;
- (b) cause a copy of such notice to be served personally or by post upon the applicant at least three days before the hearing of the application; and
- (c) send or deliver
  - (i) where the objection is not made by the officer in charge of the police district in which the Court is situated — a copy of the notice to such officer; and
  - (ii) where the objection is not made by the Registrar or Deputy Registrar — a copy to the Registrar.

<i>Full name of Applicant or in the case of a Firm or Corporation, of the Nominee</i>	<i>Place of Abode of Applicant or Nominee</i>	<i>Name of Firm or Corporation</i>	<i>Address for Registration</i>	<i>Type of Licence</i>	<i>Date of Hearing of Application</i>
Bruce Richard Graham	10 O'Loughlan Street, Ormond	Industry Funds Credit Control Pty Ltd	365 Little Collins Street, Melbourne Victoria	Commer- cial Agent	20.07.98
Helen Janice Howse	33 Lightwood Drive, Ferntree Gully 3156	Shield Mercantile Vic. Pty Ltd	259A Hampton St, Hampton, Vic. 3188	Commer- cial Sub-agent	20.07.98

PETER MITHEN

Deputy Registrar Melbourne Magistrates' Court

**Transport Act 1983****ROAD DECLARATIONS AND DEDICATIONS**

The Roads Corporation pursuant to the **Transport Act 1983**, upon publication of this notice hereby declares, or varies the declaration of, the roads as described below and on the plans attached, and further declares that such roads are fit to be used as a public highway and are now absolutely dedicated to the public for use as public highways within the meaning of any law now or hereafter in force.

**FREEWAY**

22/98 Calder Freeway in the City of Hume and the Shire of Melton shown hatched and cross hatched on plan numbered GP 19328.

**MAIN ROAD**

23/98 Meeniyen - Mirboo North Road in the South Gippsland Shire shown hatched on plan numbered GP 19474.

24/98 Clyde - Five Ways Road in the City of Casey depicted by a solid heavy line and a broken heavy line on GP 180 - MR.

25/98 Bridge Road in the City of Warrnambool depicted by a solid heavy line on plan numbered GP 176 - MR.



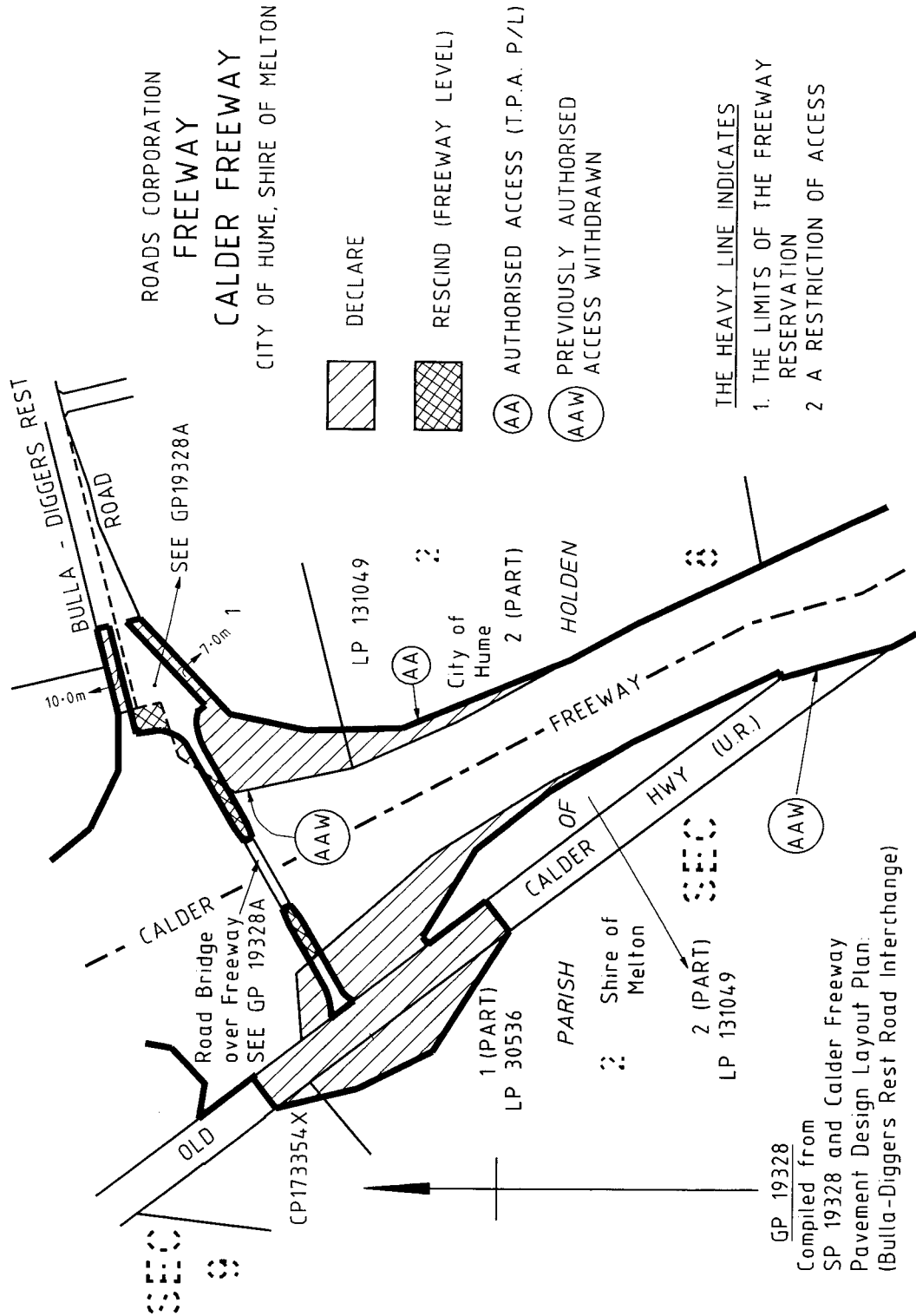

**ROAD**

26/98 Bulla - Diggers Rest Road in the City of Hume and the Shire of Melton shown hatched on plan numbered GP 19328A.

27/98 Mardan Road in the South Gippsland Shire shown hatched on plan numbered GP 19473.



ROADS CORPORATION  
**FREEWAY**  
**CALDER FREEWAY**  
 CITY OF HUME, SHIRE OF MELTON

-  DECLARE
-  RESCIND (FREEWAY LEVEL)
-  (AA) AUTHORISED ACCESS (T.P.A. P/L)
-  (AAW) PREVIOUSLY AUTHORISED ACCESS WITHDRAWN

THE HEAVY LINE INDICATES

1. THE LIMITS OF THE FREEWAY RESERVATION
2. A RESTRICTION OF ACCESS

GP 19328  
 Compiled from  
 SP 19328 and Calder Freeway  
 Pavement Design Layout Plan.  
 (Bulla-Diggers Rest Road Interchange)

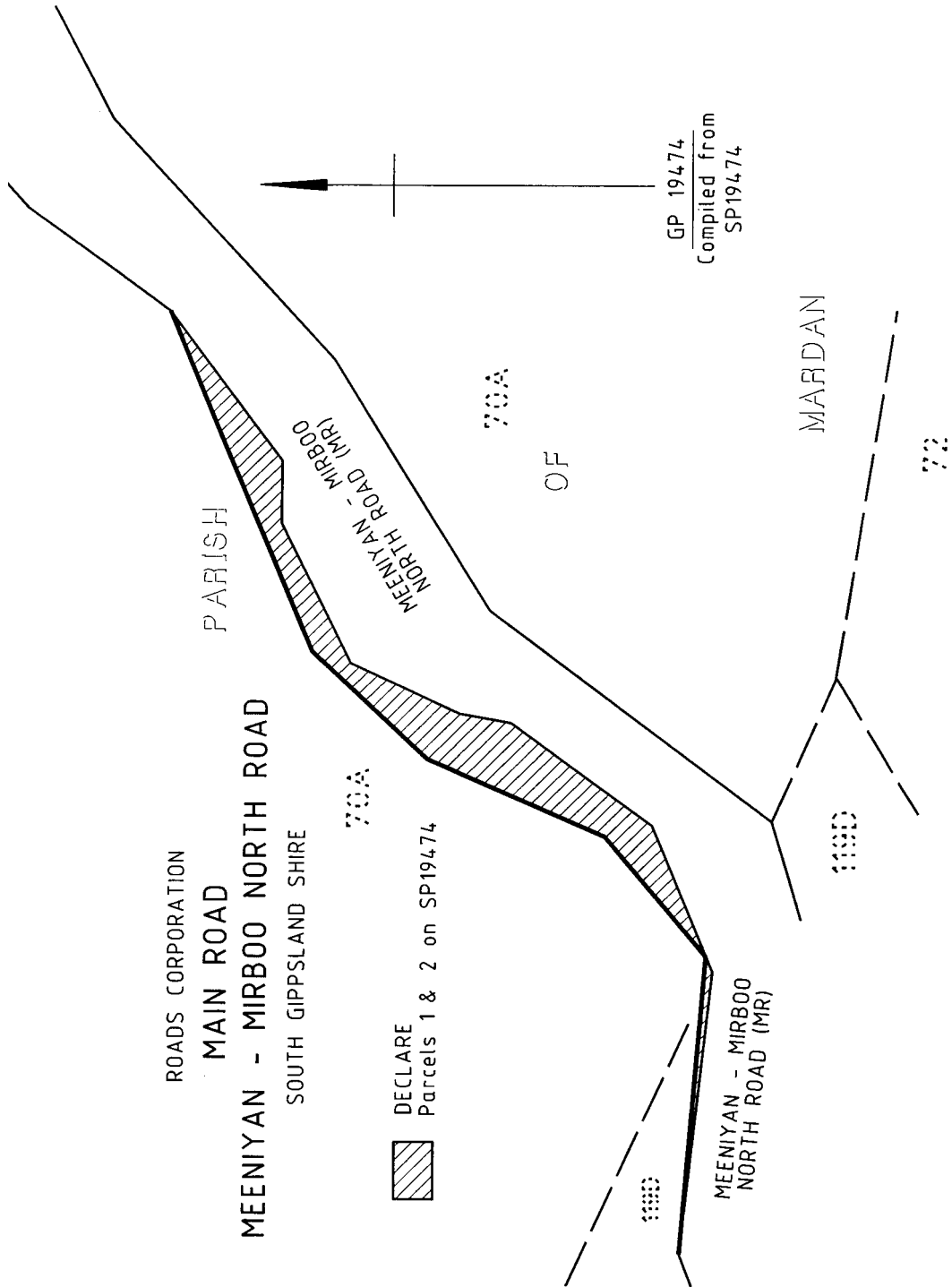

ROADS CORPORATION  
 MAIN ROAD  
 CLYDE -FIVE WAYS ROAD  
 CITY OF CASEY

LEGEND  
 \_\_\_\_\_ DECLARE  
 ..... RENAME  
 (Formerly Ballarto Road (M.R.))

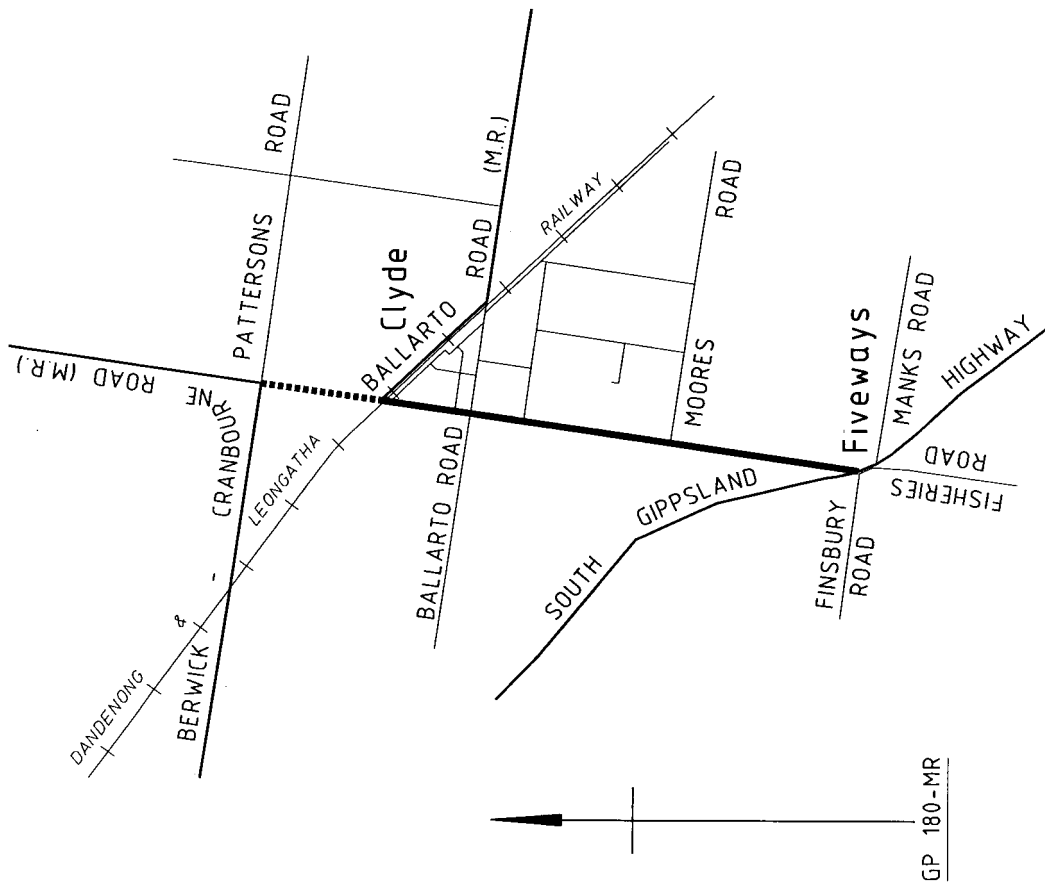

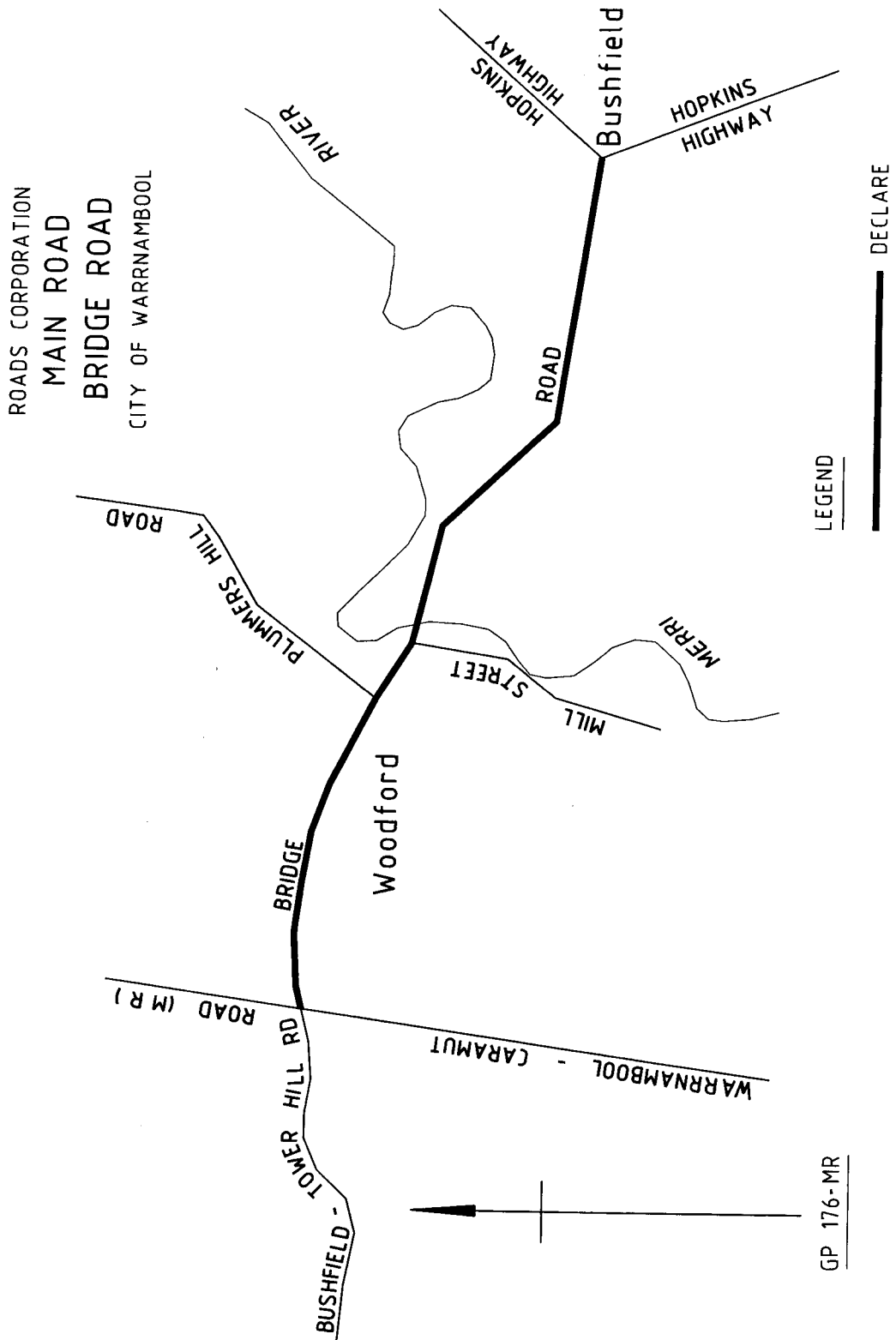

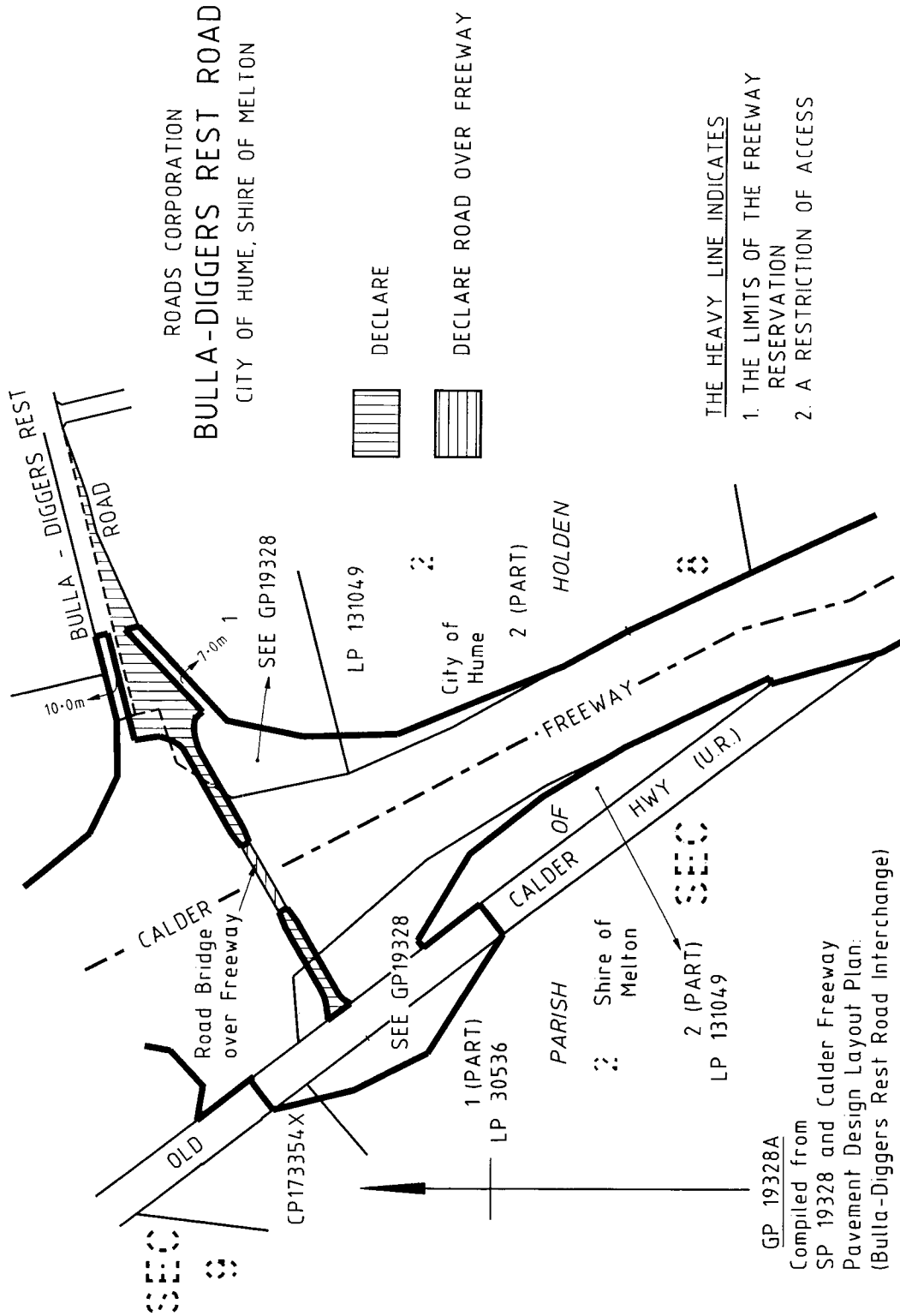



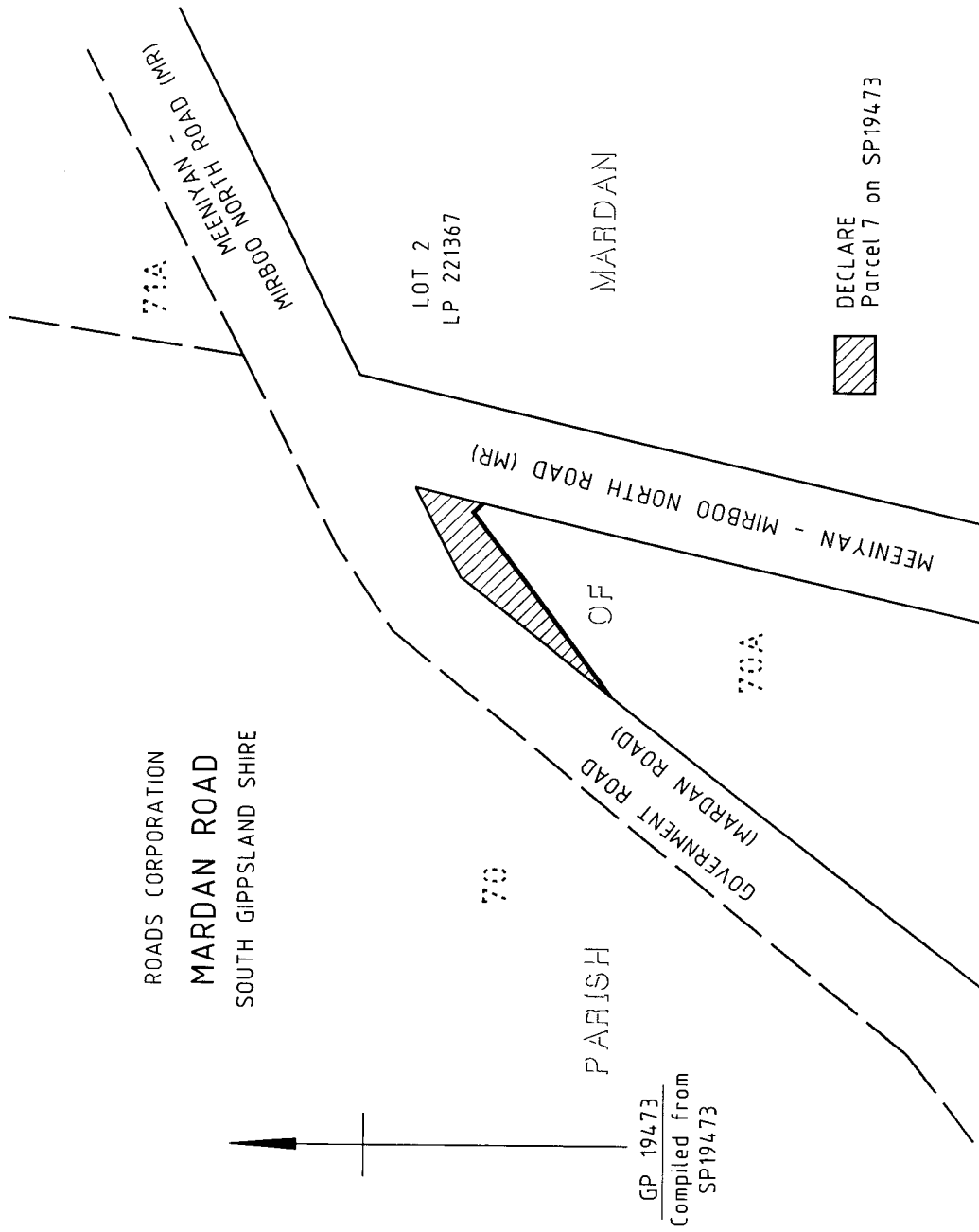

Dated 15 June 1998.

COLIN JORDAN  
Chief Executive  
Roads Corporation

**Transport Act 1983**

**DISCONTINUANCE OF ROADS OR PARTS OF ROADS AND SALE OF SURPLUS LAND**

The Roads Corporation, in pursuance of the powers conferred by Clause 2 Schedule 4 of the **Transport Act 1983**, upon publication of this notice hereby discontinues the roads or parts of roads shown cross hatched on the plan hereunder and approves the sale of surplus land as provided in Section 47 of the **Transport Act 1983** and as delegated by the Minister of Transport under Section 32 of the Act.

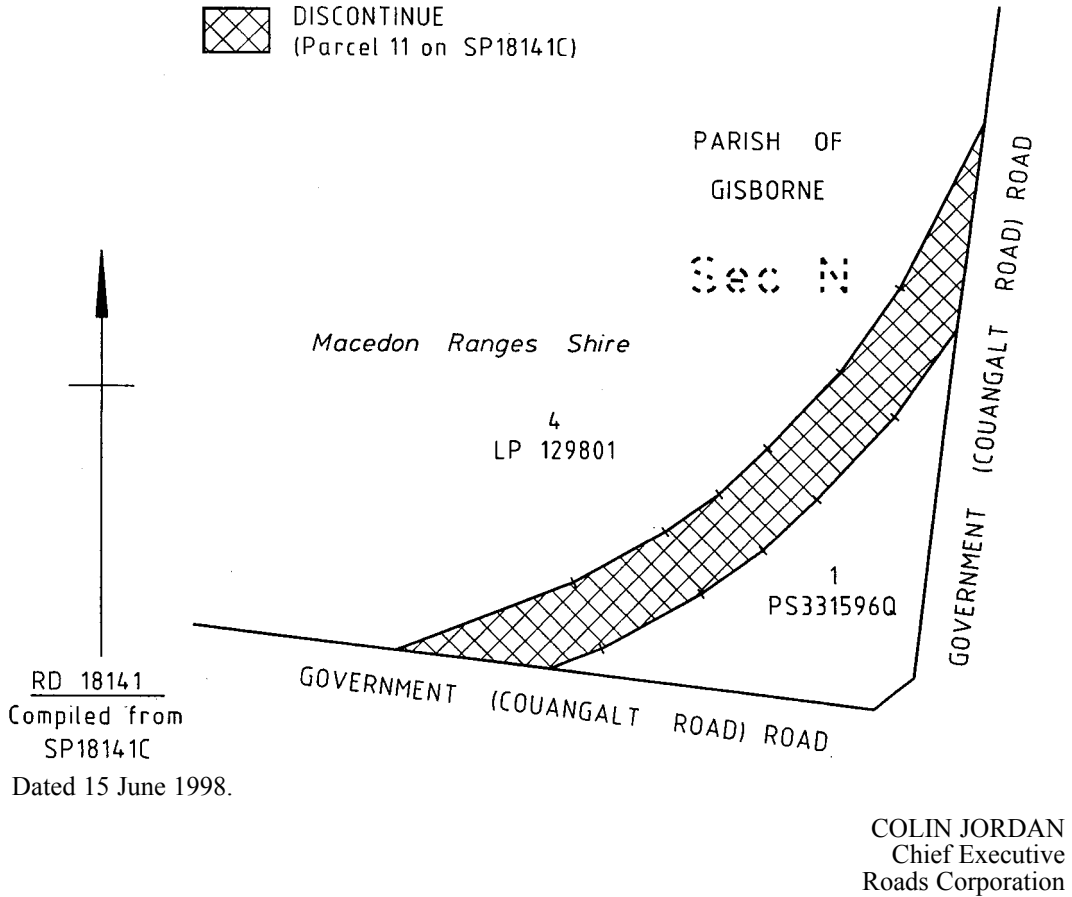

**Transport Act 1983**  
**ROADS CORPORATION ADVISORY BOARD**  
 Pursuant to Sections 30(4)(b) and 30(8) of the **Transport Act 1983** and other enabling powers, I Geoffrey Ronald Craige, Minister for Roads and Ports, hereby vary the instrument under those Sections dated 18 July 1997 as follows:  
 1. by inserting at the end of the table in paragraph 1 of the instrument:

“30(4)(b)(ix) Brian Baquie \$190 per full day meeting or \$95 per half day meeting”  
 2. by substituting “\$190” for “\$122” wherever appearing in that table;  
 3. by substituting “\$95” for “\$61” wherever appearing in that table; and  
 4. by omitting paragraph 2 of the instrument.  
 Dated 4 June 1998  
 GEOFF CRAIGE  
 Minister for Roads and Ports

**Transport Act 1983**

**TOW TRUCK DIRECTORATE OF VICTORIA**

**Tow Truck Applications**

Notice is hereby given that the following application will be considered by the Licensing Authority after 29 July 1998.

Notice of any objection to the granting of an application should be forwarded to reach the Director, Tow Truck Directorate of Victoria, Level 6, 14-20 Blackwood Street, North Melbourne (P.O. Box 666, North Melbourne 3051) not later than 23 July 1998.

It will not be necessary for interested parties to appear on the date specified, unless advised in writing.

Waverley Towing (Vic.) Pty Ltd. Application for variation of conditions of tow truck licence numbers TOW731 and TOW732 which authorise the licensed vehicles to be managed, controlled and operated from a depot situated at 41 Ricketts Road, Mount Waverley to change the depot address to 145 Somerset Road, Cambellfield.

Note: These licences are under consideration for transfer to Vicwide Auto Salvage Pty Ltd.

A. Knowles. Application for variation of conditions of tow truck licence number 021HTT which authorise the licensed vehicle to be managed, controlled and operated from a depot situated at Princes Highway, Nar Nar Goon to change the depot address to 26 Duff Street, Cranbourne.  
Dated 25 June 1998.

TERRY O'KEEFE  
Director

**Transport Act 1983**

**VICTORIAN TAXI DIRECTORATE**  
Department of Infrastructure

**Commercial Passenger Vehicle Applications**

Notice is hereby given that the following applications will be considered by the Victorian Taxi Directorate, a division of the Department of Infrastructure after 29 July 1998.

Notice of any objection to the granting of an application should be forwarded to reach the Manager, Licensing and Certification, Victorian

Taxi Directorate, Level 6, 14-20 Blackwood Street, North Melbourne (P.O. Box 666, North Melbourne 3051) not later than 23 July 1998.

Copies of objections are forwarded to the applicants

It will not be necessary for interested parties to appear on the date specified, unless advised in writing by the Department.

P. J. Price, Sunbury. Application for variation of the conditions of licence SV1139 which authorises the licensed vehicle to operate in respect of a 1980 Ford LTD stretched limousine with a seating capacity for 7 passengers to change the vehicle to a 1988 or later model Ford LTD stretched limousine with a seating capacity for 7 passengers.  
Dated 25 June 1998.

ROBERT STONEHAM  
Manager - Licensing and Certification  
Victorian Taxi Directorate

**Transport Act 1983**

**VICTORIAN TAXI DIRECTORATE**  
Department of Infrastructure

**Commercial Passenger Vehicle Applications**

**AMENDMENT TO PREVIOUS NOTICE**

This previous notice appeared in the Victoria Government Gazette No. G48 dated 4 December 1997 in the name of C. A. McKenzie, Dangenong.

Notice of any objection to the amendment should be forwarded to reach the Manager, Licensing and Certification, Victorian Taxi Directorate, Level 6, 14-20 Blackwood Street, North Melbourne (P.O. Box 666, North Melbourne 3051) not later than 23 July 1998.

On 16 June 1998, the Deputy President, Mrs K. Dimtscheff, Administrative Appeals Tribunal, ordered, the operating address of the applicant, C. A. McKenzie, Dandenong be amended from 10 Balinda Court, Dandenong to 116 High Street, Hastings.  
Dated 25 June 1998.

ROBERT STONEHAM  
Manager - Licensing and Certification  
Victorian Taxi Directorate

FORM 7 S.21  
Reg.16

NOTICE OF ACQUISITION

Compulsory Acquisition of Interest in Land

The Roads Corporation, declares that by this notice it acquires the following interest in the land described as part of Crown Allotment 55 & 60, Parish of Mangalore comprising 11.23 hectares and being land described in Certificate of Title Volume 9564 Folio 213, shown as parcels 3 & 5 and 3 & 9 on Roads Corporation Survey Plan 18968A & 18969B.

**Interest Acquired:** That of Markooma Pty Ltd as owner.

The Survey plan referred to in this notice may be viewed at the office of Property Services Department, Roads Corporation, 60 Denmark Street, Kew.

Published with the authority of the Roads Corporation.

FORM 7 S.21  
Reg.16

NOTICE OF ACQUISITION

Compulsory Acquisition of Interest in Land

The Roads Corporation, declares that by this notice it acquires the following interest in the land described as part of Crown Allotment 58, Parish of Mangalore comprising 1.104 hectares and being land described in Certificate of Title Volume 9673 Folio 885, shown as parcel 4 on Roads Corporation Survey Plan SP18968A.

**Interest Acquired:** That of Gianarelli Management Services P/L as owner.

The Survey plan referred to in this notice may be viewed at the office of Property Services Department, Roads Corporation, 60 Denmark Street, Kew.

Published with the authority of the Roads Corporation.

FORM 7 S.21  
Reg.16

NOTICE OF ACQUISITION

Compulsory Acquisition of Interest in Land

The Roads Corporation, declares that by this notice it acquires the following interest in the land described as part of Crown Allotment 61A4, Parish of Mangalore comprising 5287

square metres and being land described in Certificate of Title Volume 9168 Folio 601, shown as parcel 10 on Roads Corporation Survey Plan SP18968A.

**Interest Acquired:** That of P. J. O'Connor as owner.

The Survey plan referred to in this notice may be viewed at the office of Property Services Department, Roads Corporation, 60 Denmark Street, Kew.

Published with the authority of the Roads Corporation.

FORM 7 S.21  
Reg.16

NOTICE OF ACQUISITION

Compulsory Acquisition of Interest in Land

The Roads Corporation, declares that by this notice it acquires the following interest in the land described as part of Lot 2 on Plan of Subdivision 138060 and part of C.A.57A & 58A, Parish of Mangalore comprising 1.2254 hectares and being land described in Certificate of Title Vol 10052 Fol 907 & Crown Grants Vol 8180 Fol 283 & Vol 4435 Fol 977, shown as parcels 5, 6 & 7 on Roads Corporation Survey Plan 18969B.

**Interest Acquired:** That of O. J. & P. J. Nilsson as owner.

The Survey plan referred to in this notice may be viewed at the office of Property Services Department, Roads Corporation, 60 Denmark Street, Kew.

Published with the authority of the Roads Corporation.

FORM 7 S.21  
Reg.16

NOTICE OF ACQUISITION

Compulsory Acquisition of Interest in Land

The Roads Corporation, declares that by this notice it acquires the following interest in the land described as part of Lot 1 on Plan of Subdivision 138060, Parish of Mangalore comprising 5980 square metres and being land described in Certificate of Title Vol 9465 Folio 345, shown as parcel 8 on Roads Corporation Survey Plan 18969B.

**Interest Acquired:** That of A. W. & F. M. Semmler as owner.

The Survey plan referred to in this notice may be viewed at the office of Property Services Department, Roads Corporation, 60 Denmark Street, Kew.

Published with the authority of the Roads Corporation.

FORM 7 S.21  
Reg.16

#### NOTICE OF ACQUISITION

##### Compulsory Acquisition of Interest in Land

The Roads Corporation, declares that by this notice it acquires the following interest in the land described as part of Crown Allotment 53, 33B, 35B, 5A, 5B & 6B1, Parish of Mangalore comprising 17.29 hectares and being land described in Certificate of Title Volume 9535 Folio 080 & Volume 9664 Folio 425 & Volume 5659 Folio 771 & Volume 6608 Folio 493 &, shown as parcels 2 & 3, 3, 4, 16 & 17, & 2, 6, 7 & 8 on Roads Corporation Survey Plan 18970B, 18971A & 18974A .

**Interest Acquired:** That of F. H. Coombs as owner.

The Survey plan referred to in this notice may be viewed at the office of Property Services Department, Roads Corporation, 60 Denmark Street, Kew.

Published with the authority of the Roads Corporation.

FORM 7 S.21  
Reg.16

#### NOTICE OF ACQUISITION

##### Compulsory Acquisition of Interest in Land

The Roads Corporation, declares that by this notice it acquires the following interest in the land described as part of Crown Allotment 56A & 56B, Parish of Mangalore comprising 1.6206 hectares and being land described in Certificate of Title Volume 9716 Folio 230 & 231, shown as parcels 5 & 6 on Roads Corporation Survey Plan 18970B.

**Interest Acquired:** That of H. A. K. & T. E. Coy as owner.

The Survey plan referred to in this notice may be viewed at the office of Property Services

Department, Roads Corporation, 60 Denmark Street, Kew.

Published with the authority of the Roads Corporation.

FORM 7 S.21  
Reg.16

#### NOTICE OF ACQUISITION

##### Compulsory Acquisition of Interest in Land

The Roads Corporation, declares that by this notice it acquires the following interest in the land described as part of Crown Allotment 35, Parish of Mangalore comprising 6.710 hectares and being land described in Certificate of Title Volume 7169 Folio 783, shown as parcel 2 on Roads Corporation Survey Plan 18971A.

**Interest Acquired:** That of F. H. & A. L. Coombs as owner.

The Survey plan referred to in this notice may be viewed at the office of Property Services Department, Roads Corporation, 60 Denmark Street, Kew.

Published with the authority of the Roads Corporation.

FORM 7 S.21  
Reg.16

#### NOTICE OF ACQUISITION

##### Compulsory Acquisition of Interest in Land

The Roads Corporation, declares that by this notice it acquires the following interest in the land described as part of Crown Allotment 31, Parish of Mangalore comprising 1.578 hectares and being land described in Certificate of Title Volume 6608 Folio 492, shown as parcel 8 on Roads Corporation Survey Plan 18971A.

**Interest Acquired:** That of R. A. & R. B. Plowman as owner.

The Survey plan referred to in this notice may be viewed at the office of Property Services Department, Roads Corporation, 60 Denmark Street, Kew.

Published with the authority of the Roads Corporation.

FORM 7 S.21  
Reg.16

NOTICE OF ACQUISITION

Compulsory Acquisition of Interest in Land

The Roads Corporation, declares that by this notice it acquires the following interest in the land described as part of Crown Allotment 32A1, Parish of Mangalore comprising 1.616 hectares and being land described in Certificate of Title Volume 5043 Folio 562, shown as parcel 9 on Roads Corporation Survey Plan 18971A.

**Interest Acquired:** That of I. M. & M. D. Robinson as owner.

The Survey plan referred to in this notice may be viewed at the office of Property Services Department, Roads Corporation, 60 Denmark Street, Kew.

Published with the authority of the Roads Corporation.

FORM 7 S.21  
Reg.16

NOTICE OF ACQUISITION

Compulsory Acquisition of Interest in Land

The Roads Corporation, declares that by this notice it acquires the following interest in the land described as part of Crown Allotment 26A1, Parish of Mangalore comprising 7934 square metres and being land described in Certificate of Title Volume 8924 Folio 384, shown as parcels 5 & 11 on Roads Corporation Survey Plan 18973A.

**Interest Acquired:** That of N. G. Onans as owner.

The Survey plan referred to in this notice may be viewed at the office of Property Services Department, Roads Corporation, 60 Denmark Street, Kew.

Published with the authority of the Roads Corporation.

FORM 7 S.21  
Reg.16

NOTICE OF ACQUISITION

Compulsory Acquisition of Interest in Land

The Roads Corporation, declares that by this notice it acquires the following interest in the land described as part of Crown Allotment 26A, Parish of Mangalore comprising 2.0498

hectares and being land described in Certificate of Title Volume 10160 Folio 905, shown as parcel 6 & 12 on Roads Corporation Survey Plan 18973A.

**Interest Acquired:** That of J. L. & G. L. Knight as owner.

The Survey plan referred to in this notice may be viewed at the office of Property Services Department, Roads Corporation, 60 Denmark Street, Kew.

Published with the authority of the Roads Corporation.

FORM 7 S.21  
Reg.16

NOTICE OF ACQUISITION

Compulsory Acquisition of Interest in Land

The Roads Corporation, declares that by this notice it acquires the following interest in the land described as part of Lot 1 on Plan of Subdivision 145628, Parish of Mangalore comprising 6182 square metres and being land described in Certificate of Title Volume 9563 Fol 845, shown as parcels 9 & 15 on Roads Corporation Survey Plan 18973A.

**Interest Acquired:** That of M. J. & J. A. Cambrey as owner.

The Survey plan referred to in this notice may be viewed at the office of Property Services Department, Roads Corporation, 60 Denmark Street, Kew.

Published with the authority of the Roads Corporation.

FORM 7 S.21  
Reg.16

NOTICE OF ACQUISITION

Compulsory Acquisition of Interest in Land

The Roads Corporation, declares that by this notice it acquires the following interest in the land described as part of Lot 2 on Plan of Subdivision 145628, Parish of Mangalore comprising 1.526 hectares and being land described in Certificate of Title Volume 9563 Folio 846, shown as parcel 10 on Roads Corporation Survey Plan 18973A.

**Interest Acquired:** That of G. D. & B. M. Smith as owner and all other interests.

The Survey plan referred to in this notice

may be viewed at the office of Property Services Department, Roads Corporation, 60 Denmark Street, Kew.

Published with the authority of the Roads Corporation.

FORM 7 S.21  
Reg.16

NOTICE OF ACQUISITION

Compulsory Acquisition of Interest in Land

The Roads Corporation, declares that by this notice it acquires the following interest in the land described as part of Crown Allotments 29 and 30B, Parish of Mangalore comprising 3.1936 hectares and being land described in Certificates of Title Volume 8367 Folio 750 and Volume 6660 Folio 861, shown as parcels 16, 18 and 19 on Roads Corporation Survey Plan 18973B.

**Interest Acquired:** That of B. B. Patten as owner.

The Survey plan referred to in this notice may be viewed at the office of Property Services Department, Roads Corporation, 60 Denmark Street, Kew.

Published with the authority of the Roads Corporation.

FORM 7 S.21  
Reg.16

NOTICE OF ACQUISITION

Compulsory Acquisition of Interest in Land

The Roads Corporation, declares that by this notice it acquires the following interest in the land described as part of Lot 2 on Plan of Subdivision 204243C, Parish of Mangalore comprising 1.4988 hectares and being land described in Certificate of Title Volume 9701 Folio 490, shown as parcels 3 & 5 on Roads Corporation Survey Plan 18974A.

**Interest Acquired:** That of The Estate of R. N. Hateley deceased as owner.

The Survey plan referred to in this notice may be viewed at the office of Property Services Department, Roads Corporation, 60 Denmark Street, Kew.

Published with the authority of the Roads Corporation.

FORM 7 S.21  
Reg.16

NOTICE OF ACQUISITION

Compulsory Acquisition of Interest in Land

The Roads Corporation, declares that by this notice it acquires the following interest in the land described as part of Lot 1 on Plan of Subdivision 204243C, Parish of Mangalore comprising 1200 square metres and being land described in Certificate of Title Volume 9701 Fol 489, shown as parcel 4 on Roads Corporation Survey Plan 18974A.

**Interest Acquired:** That of G. T. Hateley as owner.

The Survey plan referred to in this notice may be viewed at the office of Property Services Department, Roads Corporation, 60 Denmark Street, Kew.

Published with the authority of the Roads Corporation.

FORM 7 S.21  
Reg.16

NOTICE OF ACQUISITION

Compulsory Acquisition of Interest in Land

The Roads Corporation, declares that by this notice it acquires the following interest in the land described as part of Crown Allotment 4C, Parish of Mangalore comprising 230 square metres and being land described in Certificate of Title Volume 8924 Folio 388, shown as parcel 9 on Roads Corporation Survey Plan 18974A.

**Interest Acquired:** That of Estate of T. J. O'Connor as owner.

The Survey plan referred to in this notice may be viewed at the office of Property Services Department, Roads Corporation, 60 Denmark Street, Kew.

Published with the authority of the Roads Corporation.

FORM 7 S.21  
Reg.16

NOTICE OF ACQUISITION

Compulsory Acquisition of Interest in Land

The Roads Corporation, declares that by this notice it acquires the following interest in the land described as part of Crown Allotment 3A, Parish of Mangalore comprising 2.0954 hectares and being land described in Certificate

of Title Volume 8924 Folio 383, shown as parcels 4 & 9 on Roads Corporation Survey Plan 18975A.

**Interest Acquired:** That of W. J. O'Connor as owner.

The Survey plan referred to in this notice may be viewed at the office of Property Services Department, Roads Corporation, 60 Denmark Street, Kew.

Published with the authority of the Roads Corporation.

---

FORM 7                      S.21  
Reg.16

NOTICE OF ACQUISITION

Compulsory Acquisition of Interest in Land

The Roads Corporation, declares that by this notice it acquires the following interest in the land described as part of Crown Allotment 3B, 3C, & 3C1, Parish of Mangalore comprising 2.4397 hectares and being land described in Certificate of Title Volume 8965 Folio 523, shown as parcels 5 & 10 on Roads Corporation Survey Plan 18975A.

**Interest Acquired:** That of T. D. C. Hutton and Estate of K. R. Hutton as owner.

The Survey plan referred to in this notice may be viewed at the office of Property Services Department, Roads Corporation, 60 Denmark Street, Kew.

Published with the authority of the Roads Corporation.

---

FORM 7                      S.21  
Reg.16

NOTICE OF ACQUISITION

Compulsory Acquisition of Interest in Land

The Roads Corporation, declares that by this notice it acquires the following interest in the land described as part of Crown Allotment 1C, 1D, 1E & 1F, Parish of Mangalore comprising 1.579 hectares and being land described in Certificate of Title Volume 8967 Folio 601 Volume 8838 Folio 395 & 396 & Volume 8989 Folio 632, shown as parcels 11, 12, 13 & 14 on Roads Corporation Survey Plan 18975A.

**Interest Acquired:** That of D. R. and A. M. Davie as owner.

The Survey plan referred to in this notice

may be viewed at the office of Property Services Department, Roads Corporation, 60 Denmark Street, Kew.

Published with the authority of the Roads Corporation.

---

FORM 7                      S.21  
Reg.16

NOTICE OF ACQUISITION

Compulsory Acquisition of Interest in Land

The Roads Corporation, declares that by this notice it acquires the following interest in the land described as part of Crown Allotment 6A SUB A & B AND 6B SUB A & B, Crown Section E, Parish of Avenel comprising 5.7699 hectares and being land described in Certificate of Title Volume 8924 Folio 387 & Volume 8924 Folio 389 & Volume 9947 Folio 085 Volume 9947 Folio 084, shown as parcels 2, 3, 4, 5, 6, 7, 8 & 9 on Roads Corporation Survey Plan 18976A.

**Interest Acquired:** That of M. J. O'Connor as owner.

The Survey plan referred to in this notice may be viewed at the office of Property Services Department, Roads Corporation, 60 Denmark Street, Kew.

Published with the authority of the Roads Corporation.

---

FORM 7                      S.21  
Reg.16

NOTICE OF ACQUISITION

Compulsory Acquisition of Interest in Land

The Roads Corporation, declares that by this notice it acquires the following interest in the land described as part of Crown Allotment 9A Sub A & B, and 10, Parish of Avenel comprising 2.385 hectares and being land described in Certificate of Title Volume 8654 Folio 572, shown as parcel 10 on Roads Corporation Survey Plan 18976A.

**Interest Acquired:** That of Tux Panor Pty Ltd as owner.

The Survey plan referred to in this notice may be viewed at the office of Property Services Department, Roads Corporation, 60 Denmark Street, Kew.

Published with the authority of the Roads Corporation.



FORM 7 S.21  
Reg.16

NOTICE OF ACQUISITION

Compulsory Acquisition of Interest in Land

The Roads Corporation, declares that by this notice it acquires the following interest in the land described as part of Crown Allotment 6A1, 6A3, 6B1 and 11(Sub B), Parish of Avenel comprising 6.9366 hectares and being land described in Certificate of Title Volume 2829 Folio 800 Volume 2829 Folio 606, shown as parcels 3, 4 & 6 on Roads Corporation Survey Plan 18977A.

**Interest Acquired:** That of I. E. Griffiths as owner.

The Survey plan referred to in this notice may be viewed at the office of Property Services Department, Roads Corporation, 60 Denmark Street, Kew.

Published with the authority of the Roads Corporation.

FORM 7 S.21  
Reg.16

NOTICE OF ACQUISITION

Compulsory Acquisition of Interest in Land

The Roads Corporation, declares that by this notice it acquires the following interest in the land described as part of Crown Allotment 10C, Crown Section E, Parish of Avenel comprising 8109 square metres and being land described in Certificate of Title Volume 152 Folio 272, shown as parcel 25 on Roads Corporation Survey Plan 18977A.

**Interest Acquired:** That of W. A. Griffiths as owner.

The Survey plan referred to in this notice may be viewed at the office of Property Services Department, Roads Corporation, 60 Denmark Street, Kew.

Published with the authority of the Roads Corporation.

FORM 7 S.21  
Reg.16

NOTICE OF ACQUISITION

Compulsory Acquisition of Interest in Land

The Roads Corporation, declares that by this notice it acquires the following interest in the

land described as part of Crown Allotment 12 (Subdivision A & B), Crown Section E, Parish of Avenel comprising 10.2765 hectares and being land described in Certificate of Title Volume 9329 Folio 943, shown as parcels 3, 6 & 11 on Roads Corporation Survey Plan 18978A.

**Interest Acquired:** That of J. G. W. & H. L. Head as owner.

The Survey plan referred to in this notice may be viewed at the office of Property Services Department, Roads Corporation, 60 Denmark Street, Kew.

Published with the authority of the Roads Corporation.

FORM 7 S.21  
Reg.16

NOTICE OF ACQUISITION

Compulsory Acquisition of Interest in Land

The Roads Corporation, declares that by this notice it acquires the following interest in the land described as part of Crown Allotment 7C, 7CA, 7CB, 7E, 8B2, 8D & Whole 8E, Crown Section F, Parish of Avenel comprising 10.961 hectares and being land described in Certificate of Title Vol 4510 Fol 910 & 911, Vol 8341 Fol 779, 780 & 781 & Vol 8103 Fol 232 Crown Grant Vol 8386 Fol 299, shown as parcels 4 & 8, & 4, 5 ,6, 7, 21 & 22 on Roads Corporation Survey Plan 18978A, 18979B.

**Interest Acquired:** That of M. T. & J. W. O'Connor as owner.

The Survey plan referred to in this notice may be viewed at the office of Property Services Department, Roads Corporation, 60 Denmark Street, Kew.

Published with the authority of the Roads Corporation.

FORM 7 S.21  
Reg.16

NOTICE OF ACQUISITION

Compulsory Acquisition of Interest in Land

The Roads Corporation, declares that by this notice it acquires the following interest in the land described as part of Crown Allotment 11 Subdivision B, Crown Section E, Parish of Avenel comprising 7783 square metres and being land described in Certificate of Title

Volume 7384 Folio 780, shown as parcel 7 on Roads Corporation Survey Plan 18978A.

**Interest Acquired:** That of P. J. O'Connor as owner.

The Survey plan referred to in this notice may be viewed at the office of Property Services Department, Roads Corporation, 60 Denmark Street, Kew.

Published with the authority of the Roads Corporation.

---

FORM 7                      S.21  
Reg.16

NOTICE OF ACQUISITION

Compulsory Acquisition of Interest in Land

The Roads Corporation, declares that by this notice it acquires the following interest in the land described as part of Crown Allotment 8A, 9A, 9B & 9C, Crown Section F, Parish of Avenel comprising 5.2377 hectares and being land described in Certificate of Title Volume 5780 Folio 983 & Volume 2725 & 995 & Volume 5611 Folio 132, shown as parcels 3, 10, 19, 25 & 8 on Roads Corporation Survey Plan 18979B & 18980B.

**Interest Acquired:** That of Chatswood Park Pty Ltd as owner.

The Survey plan referred to in this notice may be viewed at the office of Property Services Department, Roads Corporation, 60 Denmark Street, Kew.

Published with the authority of the Roads Corporation.

---

FORM 7                      S.21  
Reg.16

NOTICE OF ACQUISITION

Compulsory Acquisition of Interest in Land

The Roads Corporation, declares that by this notice it acquires the following interest in the land described as part of Crown Allotment 8B1 & the whole of C. A. 8F, Crown Section F, Parish of Avenel comprising 1.59 hectares and being land described in Certificate of Title Volume 5216 Folio 167 and whole of the land in Crown Grant Volume 8386 Folio 297, shown as parcels 8, 9 & 23 on Roads Corporation Survey Plan 18979B.

**Interest Acquired:** That of K. D. J. & F. A. Irwin as owner.

The Survey plan referred to in this notice may be viewed at the office of Property Services Department, Roads Corporation, 60 Denmark Street, Kew.

Published with the authority of the Roads Corporation.

---

FORM 7                      S.21  
Reg.16

NOTICE OF ACQUISITION

Compulsory Acquisition of Interest in Land

The Roads Corporation, declares that by this notice it acquires the following interest in the land described as part of Crown Allotment 7D, Crown Section F, Parish of Avenel comprising 1.2451 hectares and being land described in Certificate of Title Volume 8792 Folio 777, shown as parcels 16 & 20 on Roads Corporation Survey Plan 18979B.

**Interest Acquired:** That of D. G. & H. A. Traeger as owner.

The Survey plan referred to in this notice may be viewed at the office of Property Services Department, Roads Corporation, 60 Denmark Street, Kew.

Published with the authority of the Roads Corporation.

---

FORM 7                      S.21  
Reg.16

NOTICE OF ACQUISITION

Compulsory Acquisition of Interest in Land

The Roads Corporation, declares that by this notice it acquires the following interest in the land described as part of Crown Allotment 6A1, 6B1, 66A, 66B & 65B, Crown Section F, Parish of Tabilk comprising 14.0451 hectares and being land described in Certificate of Title Volume 4815 Folio 967 and Volume 39821 Folio 309, shown as parcels 3, & 3 & 6, & 4 & 12 on Roads Corporation Survey Plan 18980B, 18981A & 18982B.

**Interest Acquired:** That of K. A. Stray and the Estate of G. E. Stray as owner.

The Survey plan referred to in this notice may be viewed at the office of Property Services Department, Roads Corporation, 60 Denmark Street, Kew.

Published with the authority of the Roads Corporation.

FORM 7 S.21  
Reg.16

NOTICE OF ACQUISITION

Compulsory Acquisition of Interest in Land

The Roads Corporation, declares that by this notice it acquires the following interest in the land described as part of Crown Allotment 65A, Parish of Tabilk comprising 2.671 hectares and being land described in Certificate of Title Volume 8364 Folio 641, shown as parcel 7 on Roads Corporation Survey Plan 18982A.

**Interest Acquired:** That of K. A. Newnham as owner.

The Survey plan referred to in this notice may be viewed at the office of Property Services Department, Roads Corporation, 60 Denmark Street, Kew.

Published with the authority of the Roads Corporation.

FORM 7 S.21  
Reg.16

NOTICE OF ACQUISITION

Compulsory Acquisition of Interest in Land

The Roads Corporation, declares that by this notice it acquires the following interest in the land described as part of Crown Allotment 67B, Parish of Tabilk comprising 3.686 hectares and being land described in Certificate of Title Volume 3670 Folio 967, shown as parcels 2 & 8 on Roads Corporation Survey Plan 18983A.

**Interest Acquired:** That of the Estate of A. A. Muller as owner and all other interests.

The Survey plan referred to in this notice may be viewed at the office of Property Services Department, Roads Corporation, 60 Denmark Street, Kew.

Published with the authority of the Roads Corporation.

FORM 7 S.21  
Reg.16

NOTICE OF ACQUISITION

Compulsory Acquisition of Interest in Land

The Roads Corporation, declares that by this notice it acquires the following interest in the land described as part of Crown Allotment D3, Parish of Tabilk comprising 1.587 hectares and being land described in Certificate of Title

Volume 1814 Folio 752, shown as parcel 3 on Roads Corporation Survey Plan 18983A.

**Interest Acquired:** That of C. E. M. O'Dwyer as owner and all other interests.

The Survey plan referred to in this notice may be viewed at the office of Property Services Department, Roads Corporation, 60 Denmark Street, Kew.

Published with the authority of the Roads Corporation.

FORM 7 S.21  
Reg.16

NOTICE OF ACQUISITION

Compulsory Acquisition of Interest in Land

The Roads Corporation, declares that by this notice it acquires the following interest in the land described as the whole of Crown Allotment D4, Parish of Tabilk comprising 4047 square metres and being land described in Certificate of Title Volume 9638 Folio 028, shown as parcel 4 on Roads Corporation Survey Plan 18983A.

**Interest Acquired:** That of M. B. Mazurek & D. J. Fitzgibbon as owner.

The Survey plan referred to in this notice may be viewed at the office of Property Services Department, Roads Corporation, 60 Denmark Street, Kew.

Published with the authority of the Roads Corporation.



**Heritage**  
VICTORIA

**Heritage Act 1995**

NOTICE OF REGISTRATION

As Executive Director for the purpose of the Heritage Act, I give notice under section 46 that the Victorian Heritage Register is amended by including the Heritage Register Number 1699 in the category described as a Heritage place:

Former BHP House, 140 William Street, Melbourne, Melbourne City Council.

EXTENT:

1. All of the building known as the former BHP Building and marked B-1 on

diagram 605797 held by the Executive Director.

2. All of the land marked L1 on diagram 605797 held by the Executive Director, Heritage Council, being all of the land described in Certificate of Title Volume 9125 Folio 053.

Dated 19 March 1998.

RAY TONKIN  
Executive Director

---



**Heritage Act 1995**

**NOTICE OF REGISTRATION**

As Executive Director for the purpose of the Heritage Act, I give notice under section 46 that the Victorian Heritage Register is amended by including the Heritage Register Number 1700 in the category described as a Heritage place:

Stone Mileposts, Warrnambool Caramut Road and Keillors Road, between Caramut and Woolsthorpe, Warrnambool City Council.

**EXTENT:**

1. The entire collection of stone mileposts on Warrnambool Caramut Road and Keillors Road between Woolsthorpe and Caramut, including all of the structures' foundations, as marked B1-B4 on diagram 603345 held by the Executive Director, within a 100 metre radius of Australian Map Grid co-ordinates XC333971 on 1:25 000 map sheet number 7422-3-S (B1), 631250E & 5787750N Zone 54 (B2), 632500E & 5787500N Zone 54 (B3), 625500E & 5773500N Zone 54 (B4) and 633500E & 5796500N Zone 54 (B5).

Dated 4 June 1998.

RAY TONKIN  
Executive Director

---



**Heritage**  
VICTORIA

**Heritage Act 1995**

**NOTICE OF REGISTRATION**

As Executive Director for the purpose of the Heritage Act, I give notice under section 46 that the Victorian Heritage Register is amended by including the Heritage Register Number 1701 in the category described as a Heritage place:

Stone Mileposts, Glenelg Highway Road, between Scarsdale and Ballarat, Golden Plains Shire and Ballarat City Council.

**EXTENT:**

1. The entire collection of stone mileposts on the Glenelg Highway between Scarsdale and Ballarat, including all the structures' foundations, as marked B1, B2, B3, B4 and B5 on diagram 602339 held by the Executive Director, within a 100 metre radius of Australian Map Grid co-ordinates YD354292 (B1), YD368301 (B2) and YD378310 (B3) on 1:25 000 map sheet number 7622-4-2 and YD465359 (B4) and YD481358 (B5) on 1:25 000 map sheet number 7622-1-4.

Dated 4 June 1998.

RAY TONKIN  
Executive Director

---



**Heritage**  
VICTORIA

**Heritage Act 1995**

**NOTICE OF REGISTRATION**

As Executive Director for the purpose of the Heritage Act, I give notice under section 46 that the Victorian Heritage Register is amended by including the Heritage Register Number 1702 in the category described as a Heritage place:

Cast iron mileposts, Lismore Scarsdale Road and Rokewood Skipton Road (near) Cape Clear, Golden Plains Shire Council.

EXTENT:

1. The cast iron mileposts on the Lismore Scarsdale Road and the Rokewood Skipton Road near Cape Clear, including all of the structures' foundations, as marked B1 and B2 on diagram 602340 held by the Executive Director, within a 100 metre radius of Australian Map Grid co-ordinates YD284115 (B1) and YD299144 (B2) on 1:25 000 map sheet number 7622-3-4.

Dated 4 June 1998.

RAY TONKIN  
Executive Director

---



NOTICE OF REGISTRATION

As Executive Director for the purpose of the Heritage Act, I give notice under section 46 that the Victorian Heritage Register is amended by including the Heritage Register Number 1703 in the category described as a Heritage place:

Cast iron mileposts, Chatsworth Wickliffe Road, near Chatsworth, Moynes Shire Council.

EXTENT:

1. The entire collection of cast iron mileposts on the Chatsworth Wickliffe Road near Chatsworth, including all of the structures' foundations, as marked B1 and B2 on diagram 603344 held by the Executive Director, within a 100 metre radius of Australian Map Grid co-ordinates XD461111 (B1) and XD468125 (B2) on 1:25 000 map sheet number 7422-3-N.

Dated 4 June 1998.

RAY TONKIN  
Executive Director

---



**Heritage**  
VICTORIA

**Heritage Act 1995**

NOTICE OF REGISTRATION

As Executive Director for the purpose of the Heritage Act, I give notice under section 46 that the Victorian Heritage Register is amended by including the Heritage Register Number 1704 in the category described as a Heritage place:

Faraday Primary School No. 797, Calder Highway, Faraday, Mt Alexander Shire Council.

EXTENT:

1. All the buildings marked B1 on diagram 601961 held by the Executive Director.
2. All of the land marked L1 on diagram 601961 held by the Executive Director, being all the land described in Certificate of Title Volume 10340 Folio 648.

Dated 4 June 1998.

RAY TONKIN  
Executive Director

---



**Heritage**  
VICTORIA

**Heritage Act 1995**

NOTICE OF REGISTRATION

As Executive Director for the purpose of the Heritage Act, I give notice under section 46 that the Victorian Heritage Register is amended by including the Heritage Register Number 1705 in the category described as a Heritage place:

Newstead Courthouse, corner Canrobert and Wyndham Streets, Newstead, Mt Alexander Shire Council.

EXTENT:

1. All the building known as Newstead Courthouse, being the building marked B1 on diagram 602099 held by the Executive Director.
2. All of the land marked L1 on diagram 602099 held by the Executive Director, being all the land known as the Court House Reserve, part of Crown Allotment 31, Section 2, Parish of Newstead, Government Gazette 65.1939.

Dated 4 June 1998.

RAY TONKIN  
Executive Director

---



**Heritage Act 1995**

NOTICE OF REGISTRATION

As Executive Director for the purpose of the Heritage Act, I give notice under section 46 that the Victorian Heritage Register is amended by including the Heritage Register Number 1706 in the category described as a Heritage place:

Dodgshun House (formerly Edensor), 9 Brunswick Street, Fitzroy, Yarra City Council.

EXTENT:

1. All the buildings known as Dodgshun House, including the garden wall and gateposts, being the buildings marked B1 and B2 on diagram 603463, held by the Executive Director.
2. All of the land marked L1 on diagram 603463 held by the Executive Director, being all the land described in PS 318688K.

Dated 4 June 1998.

RAY TONKIN  
Executive Director

---



**Heritage**  
VICTORIA

**Heritage Act 1995**

NOTICE OF REGISTRATION

As Executive Director for the purpose of the Heritage Act, I give notice under section 46 that the Victorian Heritage Register is amended by including the Heritage Register Number 1707 in the category described as a Heritage place:

Auburn Primary School No. 2948, Rathmines Road, Hawthorn, Boroondara City Council.

EXTENT:

1. To the extent of the buildings being, the main school building marked B-1, the infant building marked B-2 and the three shelter sheds marked B-3, B-4 and B-5, on diagram 603757 held by the Executive Director.
2. To the extent of the land marked L-1 on diagram 603757 held by the Executive Director, being part of the land described as Volume 2185 Folio 911 part of Crown Portion 70 at Hawthorn, Parish of Boroondara.

Dated 4 June 1998.

RAY TONKIN  
Executive Director

---



**Heritage**  
VICTORIA

**Heritage Act 1995**

NOTICE OF REGISTRATION

As Executive Director for the purpose of the Heritage Act, I give notice under section 46 that the Victorian Heritage Register is amended by including the Heritage Register Number 1708

in the category described as a Heritage place:

Caulfield Primary School No. 773, Glenhantly Road, Caulfield, Glen Eira City Council.

**EXTENT:**

1. To the extent of the buildings marked B-1, B-2 and B-3 on diagram 604923 held by the Executive Director.
2. To the extent of the land marked L-1 on diagram 604923 held by the Executive Director, being part of the land described in Book 243 Pages 738, 739 and 740 of Government Gazette 16/10/1874.

Dated 4 June 1998.

RAY TONKIN  
Executive Director

---



**NOTICE OF REGISTRATION**

As Executive Director for the purpose of the Heritage Act, I give notice under section 46 that the Victorian Heritage Register is amended by including the Heritage Register Number 1709 in the category described as a Heritage place:

Infant Building and Shelter Shed, Coburg Primary School No. 484, Bell Street, Coburg, Moreland City Council.

**EXTENT:**

1. To the extent of the buildings known as the infant building marked B-1 and the shelter shed marked B-2 on diagram 602302 held by the Executive Director.
2. To the extent of the land marked L-1 on diagram 602302 held by the Executive Director, being part of the land described as Book No. 442 page 321 and Book No. 445 page 573, Crown Portion 10, Parish of Jika Jika.

Dated 4 June 1998.

RAY TONKIN  
Executive Director

---

**Heritage Act 1995**

**NOTICE OF REGISTRATION**

As Executive Director for the purpose of the Heritage Act, I give notice under section 46 that the Victorian Heritage Register is amended by including the Heritage Register Number 1710 in the category described as a Heritage place:

Malvern Primary School No. 2586, 21-27 Tooronga Road, Malvern, Port Phillip City Council.

**EXTENT:**

1. To the extent of the buildings known as the Infant Building marked B-1, the Main School Building marked B-2 and the former Domestic Arts Building marked B-3 on diagram 601775 held by the Executive Director.
2. To the extent of the land marked L-1 on diagram 601775 held by the Executive Director, being part of the land described as Vol. 1763 Fol. 412 Part of Crown Allotment 71, Parish of Prahran.

Dated 4 June 1998.

RAY TONKIN  
Executive Director

---



**Heritage Act 1995**

**NOTICE OF REGISTRATION**

As Executive Director for the purpose of the Heritage Act, I give notice under section 46 that the Victorian Heritage Register is amended by including the Heritage Register Number 1711 in the category described as a Heritage place:

Middle Park Primary School No. 2815, Richardson Street, Middle Park, Port Phillip City Council.

**EXTENT:**

1. To the extent of the buildings marked B-1 and B-2 on diagram 602489 held by the Executive Director.

2. To the extent of the land marked L-1 on diagram 602489 held by the Executive Director, being part of the land described as Reserve 5320 Section 430 of Crown Allotment 57 to 66, Government Gazette 13/8/1886 page 2331.

Dated 4 June 1998.

RAY TONKIN  
Executive Director



**Heritage**  
VICTORIA

**Heritage Act 1995**

**NOTICE OF REGISTRATION**

As Executive Director for the purpose of the Heritage Act, I give notice under section 46 that the Victorian Heritage Register is amended by including the Heritage Register Number 1712 in the category described as a Heritage place:

St Kilda Primary School No. 1479, Brighton Road, St Kilda, Port Phillip City Council.

**EXTENT:**

1. To the extent of the buildings being the main school building marked B-1 on diagram 602486 held by the Executive Director.
2. To the extent of the land marked L-1 on diagram 602486 held by the Executive Director being part of the land described as Reserve No. 37049 in Government Gazette 16/01/1874 page 96 and Government Gazette 13/03/1912 page 1145 footpath under the verandah.

Dated 4 June 1998.

RAY TONKIN  
Executive Director



**Heritage**  
VICTORIA

**Heritage Act 1995**

**NOTICE OF REGISTRATION**

As Executive Director for the purpose of the Heritage Act, I give notice under section 46 that

the Victorian Heritage Register is amended by including the Heritage Register Number 1713 in the category described as a Heritage place:

Footscray Primary School No. 253, corner Geelong Road and Barkly Street, Footscray, Maribyrnong City Council.

**EXTENT:**

1. To the extent of the buildings known as the Common School marked B-1, the Main School Building marked B-2 and the Infant Building marked B-3 on diagram 606037 held by the Executive Director.
2. To the extent of the land marked L-1 on diagram 606037 held by the Executive Director, being part of the land described as Reserve 9835 Government Gazette dated 3/6/1864 page 1205, Parish of Cat Paw Paw.

Dated 4 June 1998.

RAY TONKIN  
Executive Director



**Heritage**  
VICTORIA

**Heritage Act 1995**

**NOTICE OF REGISTRATION**

As Executive Director for the purpose of the Heritage Act, I give notice under section 46 that the Victorian Heritage Register is amended by including the Heritage Register Number 1714 in the category described as a Heritage place:

Ballarat, Dana Street Primary School No. 33, Dana Street, Ballarat, Ballarat City Council.

**EXTENT:**

1. To the extent of the buildings marked B-1, B-2, B-3 and B-4 on diagram 603854 held by the Executive Director.
2. To the extent of the land marked L-1 on diagram 603854 held by the Executive Director, being part of the land described as Reserve 7222, Section 7, Crown



Allotment 1-6 and 19, 20, Parish of Ballarat.

Dated 4 June 1998.

RAY TONKIN  
Executive Director

---



**Heritage Act 1995**

**NOTICE OF REGISTRATION**

As Executive Director for the purpose of the Heritage Act, I give notice under section 46 that the Victorian Heritage Register is amended by including the Heritage Register Number 1715 in the category described as a Heritage place:

Lockwood Primary School No. 744, Lockwood-Marong Road, Lockwood, Greater Bendigo City Council.

**EXTENT:**

1. To the extent of the buildings marked B-1 on diagram 602085 held by the Executive Director.
2. To the extent of the land marked L-1 on diagram 602085 held by the Executive Director, being part of the land described as Reserve 90, Section 20, Crown Allotment 3B in Government Gazette 8/11/1864 page 2498.

Dated 4 June 1998.

RAY TONKIN  
Executive Director

---



**Heritage Act 1995**

**NOTICE OF REGISTRATION**

As Executive Director for the purpose of the Heritage Act, I give notice under section 46 that

the Victorian Heritage Register is amended by including the Heritage Register Number 1716 in the category described as a Heritage place:

Lorne Primary School No. 2162, Grove Road, Lorne, Surf Coast Shire Council.

**EXTENT:**

1. To the extent of the buildings marked B-1, B-2 and B-3 on diagram 603551 held by the Executive Director.
2. To the extent of the land marked L-1 on diagram 603551 held by the Executive Director, being the land described as Reserve 1711, Crown Allotment 1 and 1B in Government Gazette 1878 page 582.

Dated 4 June 1998.

RAY TONKIN  
Executive Director

---



**Heritage Act 1995**

**NOTICE OF REGISTRATION**

As Executive Director for the purpose of the Heritage Act, I give notice under section 46 that the Victorian Heritage Register is amended by including the Heritage Register Number 1717 in the category described as a Heritage place:

Whittlesea Primary School No. 2090, Plenty Road, Whittlesea, Whittlesea City Council.

**EXTENT:**

1. To the extent of the buildings marked B-1 on diagram 603340 held by the Executive Director.
2. To the extent of the land marked L-1 on diagram 603340 held by the Executive Director, being the land described as Memorial 837 Book 264, Volume 9377 Folio 726, Volume 3105, Folio 836, all part of Section 3 Crown Allotment A, Township of Whittlesea.

Dated 4 June 1998.

RAY TONKIN  
Executive Director

---

**Heritage Act 1995**

## NOTICE OF REGISTRATION

As Executive Director for the purpose of the Heritage Act, I give notice under section 46 that the Victorian Heritage Register is amended by including the Heritage Register Number 1718 in the category described as a Heritage place:

Beechworth Primary School No. 1560, Junction Road, Beechworth, Indigo Shire Council.

## EXTENT:

1. To the extent of the buildings marked B-1, B-2 and B-3 on diagram 602115 held by the Executive Director.
2. To the extent of the land marked L-1 on diagram 602115 held by the Executive Director, being part of the land described as Reserve 6182 page 2254 Section 23 Crown Allotments 5 and 6, Township of Beechworth.

Dated 4 June 1998.

RAY TONKIN  
Executive Director

**Prostitution Control Act 1994**NOTICE OF MAKING OF A  
DECLARATION

In the Magistrates' Court of Victoria at  
Melbourne

Case No: Z00326011

In the Matter of an Application under Section  
80 of the **Prostitution Control Act 1994**

Upon an application by the City of Melbourne, the Magistrates' Court at Melbourne did on 18 June 1998 declare that for a period of 21 days from the date of this declaration the premises situated at and known as 299 Victoria Street, North Melbourne to be a proscribed brothel under Section 80(1) of the **Prostitution Control Act 1994**.

Dated 18 June 1998.

P. D. STREET  
Magistrate

**Road Safety Act 1986**

## SECTION 10

NOTICE OF AMENDMENT OF  
STANDARDS FOR REGISTRATION  
CONCERNING SPEED LIMITING  
DEVICES ON HEAVY TRUCKS AND  
BUSES

Section 10 of the **Road Safety Act 1986** empowers the Minister by Notice published in the Government Gazette to require compliance with standards for registration specified in the Notice relating to the construction, efficiency, performance, safety, design and equipment of and the method of identifying motor vehicles and trailers.

A Notice under that section was published in Gazette No. S15 on 1 March 1988 and a relevant amendment was made by further notice published in Gazette No. S64 on 17 December 1990.

In accordance with that section and other enabling powers, I, Geoff Craigie, Minister for Roads and Ports, amend the Notice, with effect on and from 29 June 1998, by substituting for clause 308 the following:

**“Speed Limiting of Certain Heavy Trucks and Buses**

308(1) Subject to sub-clause (2), a vehicle must comply with the standards and procedures set out in Vehicle Standards Bulletin 2 - Maximum Road Speed Limiting for Heavy Trucks and Buses, issued by the Federal Office of Road Safety, despite anything to the contrary in that Bulletin, if the vehicle is:-

- (a) a bus that:-
  - (i) has a gross vehicle mass that exceeds 14.5 tonnes;
  - (ii) was manufactured on or after 1 January 1988; and
  - (iii) has its registration under Part 2 of the **Road Safety Act 1986** renewed on or after 1 January 1991; or
- (b) a heavy goods vehicle that:-
  - (i) has a gross vehicle mass that exceeds 20 tonnes;
  - (ii) was manufactured on or after 1 January 1988; and
  - (iii) has its registration under Part 2 of the **Road Safety Act 1986** renewed on or after 1 January 1991; or
- (c) a heavy goods vehicle that:-

- (i) has a gross vehicle mass that exceeds 15 tonnes;
  - (ii) was manufactured on or after 1 January 1988; and
  - (iii) has its registration under Part 2 of the **Road Safety Act 1986** renewed on or after 1 January 1992; or
- (d) a bus of any age that:-
- (i) has a gross vehicle mass that exceeds 5 tonnes;
  - (ii) has been recorded by the Corporation as a vehicle detected on more than one occasion after 29 June 1998 travelling at a speed of more than 115 km/h; or
- (e) a heavy goods vehicle of any age that:-
- (i) has a gross vehicle mass that exceeds 12 tonnes;
  - (ii) has been recorded by the Corporation as a vehicle detected on more than one occasion after 29 June 1998 travelling at a speed of more than 115 km/h.
- (2) Paragraphs (1)(a), (b) and (c) do not apply to a motor vehicle manufactured before 1 January 1991 that:-
- (a) has had its powered speed capability limited to a speed of not more than 105 km/h since before 1 January 1991; or
  - (b) operates solely within a radius of 80 kilometres from the garaged address specified in the motor vehicle register for that vehicle, or, if no such address is specified, within a radius of 80 kilometres from the address of the registered owner specified in the register; or
  - (c) has not travelled more than 30,000 kilometres in the preceding 12 months."

The Standards for Registration contained in this Notice apply to the motor vehicles specified in clause 308 as substituted by this Notice.

The Standards for Registration as amended by this notice are available for inspection during normal business hours at the office of the Roads Corporation at 60 Denmark Street, Kew, Victoria.

Dated 18 June 1998.

GEOFF CRAIGE  
Minister for Roads and Ports

[Note: New requirements are contained in paragraphs 308(1) (d) and (e) above. The other provisions of clause 308 are unchanged from the previous version.]

#### **Reference Areas Act 1978**

#### **DIRECTIVES FOR MANAGEMENT OF REFERENCE AREAS**

I, Marie Tehan, Minister for Conservation and Land Management, under section 6(1) of the **Reference Areas Act 1978**, issue the following directives for the management of all reference areas:

Directives:

1. Management authorities must comply with the prescriptions for the protection, control and management of reference areas contained in the NRE guideline, *Management of reference areas* (2/98).
2. Entry of persons into a reference area is prohibited, except for authorised research workers, management personnel and those approved by the Minister. All persons entering a reference area will abide by the 'Conditions of Entry' appended to the NRE guideline, *Management of reference areas* (2/98).
3. Research work in reference areas is to be approved by the Manager, Flora and Fauna Statewide Programs on behalf of the Executive Director, Parks Flora and Fauna and carried out in accordance with the 'Conditions of Entry' appended to the NRE guideline, *Management of reference areas* (2/98).
4. Grazing, mineral exploration, mining, harvesting of forest produce, all other forms of harvesting (except water), quarrying, bee-keeping, educational use, recreation activities, and any other activities that conflict with the purposes of a reference area are prohibited.

Note: These Directives replace those published in the Government Gazette on 11 July 1996.

Dated 9 June 1998.

MARIE TEHAN  
Minister for Conservation and  
Land Management

**Dairy Industry Act 1992**

VICTORIAN DAIRY INDUSTRY  
AUTHORITY  
Determination

This Determination is made by the Victorian Dairy Industry Authority under the powers conferred by Section 61 of the **Dairy Industry Act 1992** and shall come into operation on 1 July 1998.

The definition and price specified in this determination applies to a new category of market milk.

The Determination of milk prices made by the Victorian Dairy Industry Authority and published in the Government Gazette dated 16 April 1998 is continued.

DETERMINATION

PART 1

DETERMINATION UNDER SECTION 3 OF  
THE **DAIRY INDUSTRY ACT 1992**

Ultra Heat Treated Milk with 5% Ultra Filtered permeate added is UHT milk as defined in the above Determination with 5% (by volume) of ultra filtered permeate added.

PART 2

PRICES PAYABLE FOR MILK SUPPLIED  
TO PROCESSORS BY THE AUTHORITY

- (n) Standardised raw milk for processing as Ultra heat treated milk with 5% ultra filtered permeate added for sale in Australia will be 38.70 cents per litre.

TOM AUSTIN  
Chairman

**Medical Practice Act 1994**

DETERMINATION OF FEES

Under Section 96 of the **Medical Practice Act 1994** I, Kerry John Breen, President of the Medical Practitioners Board of Victoria

1. Determine that the prescribed fees for the provisions of the **Medical Practice Act 1994** shall be in accordance with this Schedule for the period 1 July 1998 to 30 June 1999.

SCHEDULE

Provision	Fee\$
Fee for registration pursuant to Section 5:	
— General registration (Section 7)	\$200.00
— Specific registration (Section 8)	

— in excess of six (6) months	\$200.00
— six (6) months or less	\$100.00
Fee for renewal of general registration (Section 13(1)(b))	\$200.00
Fee for late fee for general registration (Section 13(2))	\$50.00
Fee for extension of specific registration (Section 8(2))	
— in excess of six (6) months	\$200.00
— six (6) months or less	\$100.00
Fee for Provisional registration (Section 9)	\$100.00
Fee for Restoration of name to the Register pursuant to Section 13(3) and 14(a)(b)	\$300.00
Fees for extracts/copies from the Medical Practitioners Register pursuant to Section 17(5)-	
* Single extract	\$30.00
* Multiple extracts	\$150.00 (maximum)
* Copy of Register	\$1,500.00
* Partial copy of Register	\$750.00 (maximum)
Fee for provision of Certificate of Good Standing pursuant to Section 96	\$50.00
Registration fee pursuant to <b>Mutual Recognition (Victoria) Act 1993</b> , Section 4	\$150.00
Dated 11 June 1998	

K. J. BREEN  
President

Medical Practitioners Board of Victoria

**Co-operatives Act 1996**

BROADVALE CO-OPERATIVE LIMITED  
HEATHERDALE RECREATION CLUB  
CO-OPERATIVE LTD  
LAKESIDE CO-OPERATIVE LTD  
PEMBROKE HIGH SCHOOL  
CO-OPERATIVE LIMITED  
WYCHEPROOF EDUCATION CENTRE  
CO-OPERATIVE LIMITED

Notice is hereby given in pursuance of Section 316(1) of the **Co-operatives Act 1996** and Section 572(2) of the **Corporations Act 1989** that, at the expiration of three months from the date hereof, the names of the aforementioned Co-operatives will, unless cause is shown to the

contrary, be struck off the register and the Co-operatives will be dissolved.

Dated at Melbourne this 19 June 1998

PAUL HOPKINS  
Deputy Registrar of Co-operatives

**Local Authorities Superannuation Act 1988**  
ELECTION OF THREE (3) DIRECTORS  
AND THREE (3) DEPUTY DIRECTORS TO  
THE LOCAL AUTHORITIES  
SUPERANNUATION BOARD

In accordance with regulation 22 of the Local Authorities Superannuation Board Election Procedures, I hereby declare the following candidates elected as Directors and Deputy Directors of the Local Authorities Superannuation Board for the period from 1 July 1998 to 30 June 2001:

<i>Director</i>	<i>Deputy Director</i>
Darrell Cochrane	Brian William Parkinson
William Watton	Coral Johnine Young
Anthony J. (Tony) Tuohey	Wendy-Lee McManus

D. WELLINGTON  
Returning Officer

**Electricity Industry Act 1993**

SECTION 169(3)

Schedule Of Retail Tariffs For Franchise  
Customers

This is an amended schedule of electricity prices for each of Eastern Energy Limited A.C.N. 064 651 118, CitiPower Ltd A.C.N. 064 651 056, United Energy A.C.N. 064 651 029, AGL Electricity (formerly Solaris Power) A.C.N. 064 651 083 and Powercor Australia Ltd A.C.N. 064 651 109 separately. With effect from 1 July 1998 the schedule of retail prices for franchise customers published in Government Gazette G25, 26 June 1997 will be replaced by the following:

- 1 Residential
  - 1.1 Winner Tariff GH/GL
 

Energy Prices:

    - \* Peak Periods (7 am to 11 pm  
Monday to Friday)

All consumption	17.30 c/kWh
-----------------	-------------

    - \* Off-Peak Periods (All other times)

All consumption	3.74 c/kWh
-----------------	------------

- 1.2 Residential Tariffs GD and GR
 

First 1020 kWh/quarter	11.86 c/kWh
Balance	12.50 c/kWh
- 1.3 Off-Peak Load Managed Storage Water Heating Tariff Y6/YT
 

All consumption	3.74 c/kWh
-----------------	------------

Supply under Tariff Y6/YT is available for 6 hours nightly for permanently wired water storage heaters of approved types meeting load management requirements.
- 1.4 Off-Peak Storage Water Heating Tariff Y8
 

(Available only to installations currently taking supply under this tariff)

All consumption	4.46 c/kWh
-----------------	------------

Supply under Tariff Y8 is available for 8 hours nightly for permanently wired storage water heaters of approved types.
- 1.5 Off-Peak Storage Space Heating Tariff J6/JT
 

All consumption	3.74 c/kWh
-----------------	------------

Supply under Tariff J6/JT is available for 7 hours nightly plus 3 hours each afternoon for permanently wired storage space heaters of approved types where supply is taken in conjunction with Tariff Y6/YT
- 1.6 Off-Peak Storage Space Heating Tariff J8
 

All consumption	4.46 c/kWh
-----------------	------------

Supply under Tariff J8 is available for 7 hours nightly plus 3 hours each afternoon for permanently wired storage space heaters of approved types, where supply is taken in conjunction with Tariff Y8.
- 1.7 Off-Peak Storage Space Heating Tariff J
 

All consumption	4.46 c/kWh
-----------------	------------

Supply under Tariff J is available for 7 hours nightly plus 3 hours each afternoon for permanently wired storage space heaters of approved types, where supply is not taken in conjunction with a storage water heating Tariff.
- 1.8 Supply Charge
 

On each account rendered	\$33.92/qtr
--------------------------	-------------
- 2 General Purpose Low Voltage
  - 2.1
    - (a) General Purpose Tariff E
 

First 7000 kWh/month	16.33 c/kWh
Balance	12.43 c/kWh

- Supply Charge -  
on each account rendered \$12.71/mth
- (b) Tariff E1  
(Available only to installations currently taking supply under this tariff).  
Energy Prices:  
\* 7 am to 11 pm  
- First 5500 kWh/month 19.02 c/kWh  
- Balance 12.37 c/kWh  
\* 11 pm to 7 am  
- All consumption 3.97 c/kWh  
Supply Charge -  
on each account rendered \$12.71/mth
- 2.2 Commercial Residential Tariff G  
(Available only to installations currently taking supply under this tariff)  
First 5000 kWh/month 16.75 c/kWh  
Balance 13.38 c/kWh  
Supply Charge -  
on each account rendered \$12.71/mth
- 2.3 Metered Demand Tariff V  
(Available only to installations currently taking supply under this tariff)  
Energy Price 5.27 c/kWh  
Demand Price \$18.37 /kW/mth  
The minimum chargeable demand is the higher of 100 kW or 60% of agreed demand.
- 2.4 Contract Demand Time-of-Use Tariff L  
Energy Prices  
\* Peak Periods (7 am to 11 pm Monday to Friday)  
All consumption 11.04 c/kWh  
\* Off-Peak Periods (All other times)  
All consumption 2.26c/kWh  
Demand Price \$3.66 /kW/mth  
Minimum chargeable demand 250 kW  
Supply Charge -  
on each account rendered \$343.59 /mth
- 2.5 General Purpose Time-of-Use Tariff D  
Energy Prices  
\* Peak Periods (7 am to 11 pm Monday to Friday)  
All consumption 16.50 c/kWh  
\* Off-Peak Periods (All other times)  
All consumption 3.25 c/kWh  
Supply Charge -  
on each account rendered \$12.71/mth
- 2.6 Resale Price  
Price for reselling (applicable to premises such as caravan parks where the proprietor is authorised under the Electric Light and Power Act to charge customers for electricity actually used).  
Maximum resale price where token or prepayment meters are installed:  
all energy 12.50 c/kWh  
Resale price where kilowatt hour (kWh) meters are installed: as per Tariff GD/GR
3. Community Service  
3.1 Community Service Tariff N  
All consumption 14.40 c/kWh  
Supply Charge -  
on each account rendered \$14.60/mth
- 3.2 Tariff N1  
(Available only to installations currently taking supply under this tariff)  
Energy Prices  
\* 7am to 11pm -  
All consumption 14.40 c/kWh  
\* 11pm to 7am -  
All consumption 4.56 c/kWh  
Supply Charge -  
on each account rendered \$14.60/mth
- 4 Farm  
4.1 Farm Tariff B  
Energy Prices:  
First 690 kWh/quarter 19.84 c/kWh  
Next 14310 kWh/quarter 18.33 c/kWh  
Next 72000 kWh/quarter 15.32 c/kWh  
Balance 14.21 c/kWh  
Supply Charge -  
on each account rendered \$43.78/qtr
- 4.2 Tariff B1  
(Available only to installations currently taking supply under this tariff).  
Energy Prices:  
\* 7 am to 11 pm  
First 690 kWh/quarter 19.84 c/kWh  
Next 14310 kWh/quarter 18.33 c/kWh  
Next 72000 kWh/quarter 15.32 c/kWh  
Balance 14.21 c/kWh  
\* 11 pm to 7 am -  
All consumption 4.56 c/kWh  
Supply Charge -  
on each account rendered \$43.78/qtr

## 5 General Purpose High Voltage

## 5.1 General Purpose Tariff E5

(Available only to installations currently taking supply under this tariff).

## Energy Prices:

* 7 am to 11 pm	
First 5500 kWh/month	22.09 c/kWh
Balance	14.39 c/kWh
* 11 pm to 7 am	
All consumption	4.63 c/kWh
Supply Charge -	
on each account rendered	\$15.70/mth

## 5.2 Contract Demand Time-of-Use Tariff H

	Option 1	Option 2	Option 3
Voltage levels (kV)	6.6/11/22	66	220 & above
Energy Prices (c/kWh)			
* Peak Periods (7am - 11pm Mon to Fri)	9.10	7.36	6.75
* Off-Peak Periods (All other times)	1.92	1.77	1.69
Demand Price (\$/kW/month)	3.76	4.80	4.88
Minimum Chargeable demand (kW)	1000	10,000	40,000

\*This option is not offered by Eastern Energy Limited

## 6 Public Lighting

## 6.1 Lanterns on Current Offer

TYPE AND RATING OF LANTERN		ALL NIGHT	24 HOUR DAILY
		\$ pa	\$ pa
Mercury	80W	79.53	—
Mercury	125W	104.36	—
Sodium <sup>E</sup>	100W	97.24	—
Sodium	150W	148.98	328.90
Sodium	250W	178.49	417.08
Sodium	400W	276.00	—

## 6.2 Lanterns NOT on Current Offer (for existing installations only)

TYPE AND RATING OF LANTERN		ALL NIGHT	SPECIAL ALL NIGHT	24 HOUR DAILY
		\$ pa	\$ pa	\$ pa
Incandescent	100W	240.39	306.60	—
Incandescent	150W	293.64	—	—
Incandescent	200W	311.28	341.15	—
Incandescent	300W	366.69	—	—
Incandescent	500W	440.46	468.89	—
Incandescent	750W	539.07	—	—
Fluorescent	2X20W	89.96	105.07	143.94
Fluorescent	3X20W	106.87	—	182.80
Fluorescent	4X40W	252.98	—	—
Mercury	50W	86.00	—	—
Mercury	250W	256.94	—	—
Mercury	400W	307.31	—	—
Mercury				
(excluding pole)	700W	460.25	499.84	—
(including pole)	700W	557.06	—	—
Sodium	90W	207.99	—	306.96

Sodium	180W	270.60	—	—
Sodium (one lamp)	2X400W	391.88	—	—
Sodium (two lamps)	2X400W	544.47	—	—
7 MISCELLANEOUS CHARGES				
7.1 Traffic Control Signals				
Supply charge each metered installation		\$14.60 per month		
(if installation is not metered)		\$10.21 per month)		
plus energy charge of		8.14 c/kWh.		
7.2 Security Lighting				
Domestic and Commercial Residential "Light Sentry"			Load Profile Fixed Charge/qtr	188.92
2 x 20W fluorescent or 50W mercury lamp	\$34.07 per quarter (retained for existing installations only)		Sub-Metering Fixed Charge/qtr	10.22
			Cathodic Protection Charge/qtr	51.10
			Flow Monitor Charge/qtr	51.10
			Noise Monitoring Station Charge/qtr	51.10
			Repeater Station Charge/qtr	51.10
7.3 Commercial, Industrial and Farm "Watchman Light"				
Initial charge per lamp	\$179.93		Sprinkler System Charge/qtr	51.10
plus the following charges per lamp:			Traffic Counting Station Charge/qtr	51.10
TYPE AND RATING OF LAMP			Telemetry Station Charge/qtr	51.10
	CHARGE/MONTH (\$)		Ticket Dispensing Station Charge/qtr	51.10
Mercury 125W	10.40	FQ 3x20W Lights two third share/qtr		17.81
Mercury 250W	17.92	FR 2x20W Lights two third share/qtr		14.99
Mercury 400W	25.21	FS 3x20W Lights one third share/qtr		8.90
Sodium 150W	17.78	FT 2x20W Lights one third share/qtr		7.49
Sodium 250W	21.39	FV 3x20W Lights half share/qtr		13.37
Sodium 400W	26.30	FW 2x20W		
		Lights half share 24 hour/qtr		17.99
		FX 2x20W fluorescent 24 hour burning/qtr		35.98
7.4 Telecom Telephone Cabinets				
1 x 20W fluorescent, plus energy used by STD telephone (24 hour operation).			FY 3x20W fluorescent 24 hour burning/qtr	45.69
Provision of unmetered energy only per cabinet per year.	\$35.63		FZ 4x40W fluorescent 24 hour burning/qtr	21.08
			F1 1x20W fluorescent Phone Cabinet/qtr	8.90
7.5 Unmetered Supplies				
	CHARGE (\$)		F2 2x20W fluorescent/qtr	22.49
Less than 50 Watts/mth	17.04	F3 3x20W fluorescent/qtr		26.72
Mobile X-Ray unit or equivalent/day	10.04	F4 4x20W fluorescent/qtr		63.24
Identilite/sign/qtr	59.69	F5 1x20W fluorescent/qtr		22.49
Telecom Remote Customer Multiplexer/mth	34.11	F6 2x20W fluorescent navigation/qtr		26.27
Mobile radio network/mth	42.07	IA 100W incandescent/qtr		60.10
Remote weather stations/mth	16.03	IC 150W incandescent/qtr		73.41
Metrolite bus shelters -		IG 100W incandescent navigation/qtr		76.85
S1 Full advertising/mth	26.70	IH 500W incandescent navigation/qtr		117.22
S2 Limited advertising/mth	19.41	IJ 4x100W incandescent pedestrian/qtr		120.19
S3 Vandal-proof no advertising/mth	16.72	I2 200W incandescent/qtr		77.81
Ice warning lamps/mth	15.92	I3 300W incandescent/qtr		91.67
8. Other Unmetered Supplies <sup>s</sup>	CHARGE\$	I4 200W incandescent navigation/qtr		85.28
		I5 500W incandescent/qtr		110.11
		I7 750W incandescent/qtr		134.76
		MA 80W Mercury Half share/qtr		9.95



MB 250W Mercury Half share/qtr	32.12	SH 150W	
MD 400W Mercury Half share/qtr	38.08	Sodium high pressure one third share/qtr	17.79
ME 700W Mercury including pole/qtr	139.26	SJ250W	
MF 125W		Sodium high pressure one third share/qtr	14.88
Mercury Wlight-one third share/qtr	10.41	SK 250W	
MG 250W		Sodium HP Wlight one third share/qtr	21.39
Mercury - one third share/qtr	21.41	SL 400W	
MH250W		Sodium high pressure one third share/qtr	23.00
Mercury Wlight - one third share/qtr	17.92	SN 90W Sodium LP one third share/qtr	17.33
MJ400W Mercury - one third share/qtr	25.61	SO 150W Sodium one sixth share/qtr	6.21
MK 400W		SR 400W	
Mercury Wlight-one third share/qtr	25.21	Sodium HP Wlight one third share/qtr	26.30
ML 700W Mercury		ST 400W Sodium one sixth share/qtr	11.50
excluding pole one third share/qtr	38.36	SU 150W Sodium two third share/qtr	24.83
MM 700W Mercury		SV 90W Sodium LP 24 hour/qtr	76.74
including pole one third share/qtr	46.42	SX 150W Sodium HP 24 hour/qtr	82.22
MN 700W Mercury navigation/qtr	124.95	SY 250W Sodium HP 24 hour/qtr	104.26
MP 250W Mercury one sixth share/qtr	10.71	S4 400W Sodium high pressure/qtr	69.00
MQ 400W Mercury one sixth share/qtr	12.81	S5 250W Sodium high pressure/qtr	44.62
MR 80W Mercury one sixth share/qtr	3.32	S6 150W Sodium high pressure/qtr	37.24
MS 80W Mercury two third share/qtr	13.26	S9 90W Sodium high pressure/qtr	51.99
MT 250W Mercury two third share/qtr	42.82	9 Telstra Remote Interface Multiplexor	
M1 125W Mercury/qtr	26.09	Equipment Tariffs E	
M2 250W Mercury	64.23	480 Line Cabinet	
M4 400W Mercury/qtr	76.83	Peak charge	16.50 c/kWh
M5 50W Mercury/qtr	21.50	Off-peak charge	3.25 c/kWh
M7 700W Mercury excluding pole/qtr	115.06	Supply charge	106.74 p.a.
M8 80W Mercury/qtr	19.88	240 Line Cabinet	
SA 150W Sodium half share/qtr	18.62	Peak charge	16.50 c/kWh
SB 180W Sodium high pressure/qtr	67.65	Off-peak charge	3.25 c/kWh
SC 250W Sodium half share/qtr	22.31	Supply charge	106.74 p.a.
SD 2x400W		180 Line Cabinet	
Sodium high pressure1 lamp/qtr	97.96	Peak charge	16.50 c/kWh
SE 2x400W		Off-peak charge	3.25 c/kWh
Sodium high pressure 2 lamps/qtr	136.11	Supply charge	106.74 p.a.
SF 400W Sodium half share/qtr	34.50	<sup>E</sup> These tariffs apply to Eastern Energy only	
SG 180W		<sup>S</sup> These tariffs apply to Solaris Power only	
Sodium high pressure one third share/qtr	12.41		

### Accident Compensation Act 1985

#### NOTICE OF INDEXED BENEFIT LEVELS AND OTHER AMOUNTS IN ACCORDANCE WITH SECTION 100 OF THE ACCIDENT COMPENSATION ACT 1985

Section 100 (1) of the Accident Compensation Act 1985 stipulates that amounts in Part IV and in Section 5A of the Act are varied on 1 July each year in line with the movement in the average weekly earnings for all employees in Victoria between the two previous December quarters, using the latest figures published by the Australian Statistician as at 30 May following the previous December quarter. Weekly payments are indexed on the anniversary of the entitlement to weekly payments as detailed in Section 100(2) of the Act.

The average weekly earnings for all employees in Victoria between the December quarter of 1996 and the December quarter 1997 increased from \$577.50 to \$600.60 which is an increase of 4.0%.

Following legislative changes in December 1997 some sections are indexed by the rise in CPI. The

Consumer Price Index between the December quarter of 1996 and the December quarter of 1997 decreased from 119.9 to 119.8. No adjustment is necessary for negative CPI movement.

Section	Provision	Rate before 1 July 98	Rate from 1 July 98
<b>COMPENSATION FOR DEATH OF A WORKER (CPI)</b>			
<b>Revised compensation for death of worker</b>			
92A(4)	For a dependent spouse or spouses in equal shares	\$ 175,000	\$ 175,000
92A(5)	For an orphan child or orphan children in equal shares	\$ 175,000	\$ 175,000
92A(6)(a)	For a dependent spouse(s) where there is one dependent child	\$ 157,000	\$ 157,000
92A(6)(b)	For the dependent child	\$ 17,500	\$ 17,500
92A(7)	For a dependent spouse(s) where there is more than one dependent child but not more than 5 dependent children payable in the following shares: total amount of	\$ 175,000	\$ 175,000
92A(7)(a)	To each dependent child	\$ 8,750	\$ 8,750
92A(7)(b)	To spouse/spouses	Balance	Balance
92A(8)	For a dependent spouse(s) where there are more than 5 dependent children payable in the following shares: total amount of	\$ 175,000	\$ 175,000
92A(8)(a)	To spouse/spouses	\$ 131,250	\$ 131,250
92A(8)(b)	To each dependent child in equal shares	\$ 43,750	\$ 43,750
92A(9)	Maximum lump sum for any other dependants if no dependent spouse or dependent child	\$ 175,000	\$ 175,000
<b>WEEKLY PENSIONS FOR DEPENDENTS OF WORKER WHO DIES (AWE)</b>			
<b>During the first 13 weeks</b>			
92B(3)(a)(ii)	Maximum weekly pension for a dependent spouse	\$ 850	\$ 884
92B(4)(a)(ii)	Maximum weekly pension for 2 or more dependent spouses in equal shares	\$ 850	\$ 884
92B(5)(a)(ii)	Maximum weekly pension for one orphan child	\$ 850	\$ 884
92B(6)(a)(ii)	Maximum weekly pension for 2 or more orphan children in equal shares	\$ 850	\$ 884
<b>After first 13 weeks until the end of 3 years</b>			
92B(3)(b)(i)	Maximum weekly pension for a dependent spouse	\$ 850	\$ 884
92B(3)(b)(ii)	Weekly pension calculation for a dependent spouse where there are not more than 5 dependent children and overall cap applies	\$ 850	\$ 884
92B(3)(b)(iii)	Weekly pension for a dependent spouse where there are more than 5 dependent children and overall cap applies	\$ 567	\$ 590
92B(4)(b)(i)	Maximum weekly pension for 2 or more dependent spouses in equal shares	\$ 850	\$ 884
92B(4)(b)(ii)	Weekly pension calculation for 2 or more dependent spouses, where there are not more than 5 dependent children and overall cap applies	\$ 850	\$ 884
92B(4)(b)(iii)	Weekly pension for 2 or more dependent spouses, where there are more than 5 dependent children and overall cap applies in equal shares	\$ 567	\$ 590

	<b>After first 13 weeks until child ceases to be eligible</b>			
92B(5)(b)(ii)	Maximum weekly pension for one orphan child	\$	850	\$ 884
92B(6)(b)(ii)	Maximum weekly pension for 2 or more orphan children in equal shares	\$	850	\$ 884
92B(7)(b)	Weekly pension calculation for each dependent child where there are not more than 5 dependent children and overall cap applies	\$	850	\$ 884
92B(8)(b)	Weekly pension for dependent children where there are more than 5 dependent children and overall cap applies in equal shares	\$	283	\$ 294
92B(11)	Total amount of weekly pensions	\$	850	\$ 884
<b>WEEKLY PAYMENTS (AWE)</b>				
	<b>First 26 weeks incapacity</b>			
	<b>Where worker has no current work capacity</b>			
93A(2)(a)(ii)	Maximum weekly payment	\$	680	\$ 707
	<b>Where worker has a current work capacity</b>			
93A(2)(b)(ii)	Maximum weekly payments - less notional earnings	\$	680	\$ 707
	<b>After 26 weeks incapacity</b>			
	<b>Worker has a serious injury</b>			
93B(1)(a)(ii)	Maximum weekly payment is - less 90% of notional earnings	\$	680	\$ 707
	<b>Worker does not have a serious injury but has no current work capacity</b>			
93B(1)(b)(ii)	Maximum weekly payments	\$	680	\$ 707
	<b>Worker does not have a serious injury but has a current work capacity</b>			
93B(1)(c)(ii)	Maximum weekly payment is - less 60% of notional earnings	\$	408	\$ 424
<b>GRANDFATHER PROVISIONS (AWE)</b>				
93C(5)(c)(iii)	Minimum earnings for a worker who has a current work capacity after 104 weeks of payments	\$	100	\$ 104
93C(11)(b)(iii)	Minimum earnings for a worker who has a current work capacity after 104 weeks of payments	\$	100	\$ 104
<b>WEEKLY PAYMENTS (AWE)</b>				
	<b>Weekly payments for First Entitlement Period (first 13 weeks)</b>			
93CA(2)(a)(ii)	Maximum weekly payment where worker has no current work capacity	\$	850	\$ 884
93CA(2)(b)(ii)	Maximum weekly payment where worker has a current work capacity - less notional earnings	\$	850	\$ 884
	<b>Weekly payments for Second Entitlement Period (13-104 weeks)</b>			
93CB(2)(a)(ii)	Maximum weekly payment where worker has no current work capacity	\$	850	\$ 884
93CB(2)(b)(ii)	Maximum weekly payment where worker has a current work capacity - less 60% of notional earnings	\$	510	\$ 530
	<b>Weekly payment after the expiry of the second entitlement period</b>			
93CC(2)(b)	Maximum weekly payment where worker has been assessed			

	as having no current work capacity and likely to continue indefinitely to have no current work capacity	\$ 850	\$ 884
93CD(3)(a)	Minimum earnings for a worker who has returned to work	\$ 100	\$ 104
93CD(5)(b)	Maximum weekly payment where Authority or self-insurer has made a determination - less 60% of worker's current weekly earnings	\$ 510	\$ 530

**COMPENSATION FOR NON-ECONOMIC LOSS (CPI)****Permanent Impairment - Calculations of Amounts of Non-economic Loss**

98C(2)(b)	Where worker's degree of impairment is not less than 10% and not more than 30%	\$ 5,000 \$ 2,000	\$ 5,000 \$ 2,000
98C(2)(c)	Where worker's degree of impairment is more than 30% and not more than 70%	\$ 45,000 \$ 3,250	\$ 45,000 \$ 3,250
98C(2)(d)	Where worker's degree of impairment is more than 70% and not more than 80%	\$ 175,000 \$ 12,500	\$ 175,000 \$ 12,500
98C(2)(e)	Where worker's degree of impairment is more than 80%	\$ 300,000	\$ 300,000

**Psychiatric Impairment - Calculations of Amounts of Non-economic Loss**

98C(3)(b)	Where worker's degree of impairment is not less than 30% and not more than 50%	\$ 10,000 \$ 3,250	\$ 10,000 \$ 3,250
98C(3)(c)	Where worker's degree of impairment is not less than 50% and not more than 70%	\$ 75,000 \$ 5,000	\$ 75,000 \$ 5,000
98C(3)(d)	Where worker's degree of impairment is not less than 70% and not more than 80%	\$ 175,000 \$ 12,500	\$ 175,000 \$ 12,500
98C(3)(e)	Where worker's degree of impairment is more than 80%	\$ 300,000	\$ 300,000

**Other non-economic loss**

98C(4)	Loss of a foetus or loss of more than one foetus	\$ 45,000	\$ 45,000
98C(7)	Maximum amount of compensation for more than one injury suffered on the same occasion	\$ 300,000	\$ 300,000
98C(8)	Maximum amount of compensation for more than one kind of non-economic loss for the same injury	\$ 300,000	\$ 300,000

**NO DISADVANTAGE - COMPENSATION TABLE (AWE)**

98E	Total loss of the sight of both eyes	\$ 161,390	\$ 167,850
	Total loss of the sight of an only eye	\$ 161,390	\$ 167,850
	Loss of both hands	\$ 161,390	\$ 167,850
	Loss of both feet	\$ 161,390	\$ 167,850
	Loss of a hand and a foot	\$ 161,390	\$ 167,850
	Total loss of the right arm or of the greater part of the right arm	\$ 129,112	\$ 134,280
	Total loss of the left arm or of the greater part of the left arm	\$ 121,043	\$ 125,880
	Total loss of the right hand or of five fingers of the right hand, or of the lower part of the right arm	\$ 112,973	\$ 117,490
	Total loss of the left hand or of five fingers of the left hand, or of the lower part of the left arm	\$ 104,904	\$ 109,100
	Total loss of a leg	\$ 121,043	\$ 125,880

Total loss of a foot	\$ 104,904	\$ 109,100
Total loss of the lower part of the leg	\$ 112,973	\$ 117,490
Total loss of the sight of one eye, together with the serious diminution of the sight of the other eye	\$ 121,043	\$ 125,880
Total loss of hearing	\$ 104,904	\$ 109,100
Total loss of the sight of one eye	\$ 64,556	\$ 67,140
Loss of binocular vision	\$ 64,556	\$ 67,140
Loss of eyeball (in addition to compensation for loss of sight of an eye)	\$ 35,506	\$ 36,930
Total loss of power of speech	\$ 96,834	\$ 100,710
Total loss of sense of taste or smell	\$ 27,436	\$ 28,530
Total loss of senses of both taste and smell	\$ 54,873	\$ 57,070
Total loss of male sexual organs	\$ 75,853	\$ 78,890
Total loss of penis	\$ 75,853	\$ 78,890
Total loss of one testicle	\$ 16,139	\$ 16,780
Total loss of two testicles or an only testicle	\$ 75,853	\$ 78,890
Total loss of female sexual organs	\$ 75,853	\$ 78,890
Total loss of both breasts	\$ 75,853	\$ 78,890
Total loss of one breast	\$ 48,417	\$ 50,350
Total loss of the thumb of the right hand	\$ 48,417	\$ 50,350
Total loss of the thumb of the left hand	\$ 41,961	\$ 43,640
Total loss of the forefinger of the right hand	\$ 33,892	\$ 35,250
Total loss of the forefinger of the left hand	\$ 29,050	\$ 30,210
Total loss of two joints of the forefinger of the right hand	\$ 25,822	\$ 26,850
Total loss of two joints of the forefinger of the left hand	\$ 19,367	\$ 20,140
Total loss of a joint of the thumb	\$ 25,822	\$ 26,850
Total loss of the first joint of the forefinger of the right hand	\$ 16,139	\$ 16,780
Total loss of the first joint of the forefinger of the left hand	\$ 14,525	\$ 15,110
Total loss of the first joint of the middle or little or ring finger of either hand	\$ 9,683	\$ 10,070
Total loss of the middle finger of either hand	\$ 19,367	\$ 20,140
Total loss of the little or ring finger of either hand	\$ 17,753	\$ 18,460
Total loss of two joints of the middle finger of either hand	\$ 16,139	\$ 16,780
Total loss of two joints of the little or ring finger of either hand	\$ 14,525	\$ 15,110
Total loss of the great toe of either foot	\$ 35,506	\$ 36,930
Total loss of a joint of the great toe of either foot	\$ 16,139	\$ 16,780
Total loss of any other toe	\$ 9,683	\$ 10,070
Total loss of a joint of any other toe	\$ 3,228	\$ 3,360
Quadriplegia	\$ 161,390	\$ 167,850
Paraplegia	\$ 161,390	\$ 167,850
Total impairment of the spine	\$ 161,390	\$ 167,850

**MEDICAL AND LIKE SERVICES (CPI)**

99(1)(aa)	Maximum Family Counselling expenses	\$ 1,570	\$ 1,570
99(5)	Employer's Liability	\$ 426	\$ 426
125(1)(a)(iii)	Employer's initial liability for medical and like services	\$ 426	\$ 426
125A(3)(c)	Employer's initial liability for medical and like services	\$ 426	\$ 426

**LIABILITY OF PRIOR INSURER (AWE)**

129B (7)	Minimum payments for contribution injury	\$ 8,460	\$ 8,800
----------	--	----------	----------

**ACTIONS FOR DAMAGES****Pecuniary Loss (AWE)**

135A(7)(a)(i)	Threshold	\$ 33,670	\$ 35,020
135A(7)(a)(ii)	Maximum	\$ 757,930	\$ 788,250

**Pain and Suffering (CPI)**

135A(7)(b)(i)	Threshold	\$ 33,670	\$ 33,670
135A(7)(b)(ii)	Maximum	\$ 341,640	\$ 341,640

**Damages under Part III of the Wrongs Act 1958 (AWE)**

135C(2)	Death of a person	\$ 500,000	\$ 520,000
---------	-------------------	------------	------------

**PRE-INJURY AVERAGE WEEKLY EARNINGS (AWE)**

5A (8)	Where no rate applicable	\$ 850	\$ 884
5A(9)(b)	Deemed Pre-injury Average Weekly Earnings for a full-time student at time of completion of course	\$ 850	\$ 884
5A(11)(b)	Deemed Pre-injury Average Weekly earnings for a full-time student at a primary or secondary school at time of completion of secondary school	\$ 680	\$ 707

**Planning and Environment Act 1987****BELFAST PLANNING SCHEME**

## Notice of Approval of Amendment

## Amendment L16

The Minister for Planning and Local Government has approved Amendment L16 to the Belfast Planning Scheme.

The Amendment comes into operation on the date this notice is published in the Government Gazette.

The Amendment deletes Diagram 1 to Chapter 1: Tower Hill, Clause 6D.1 of the Belfast Planning Scheme and replaces it with a revised diagram providing greater development setback from and restricted vehicular access to dunes at part of Rutledge's Farnham Crown Special Survey, Survey Lane, Tower Hill.

A copy of the Amendment can be inspected, free of charge, during office hours, at the Department of Infrastructure, Customer Service Centre, Upper Plaza, Nauru House, 80 Collins

Street, Melbourne and at the offices of the Moyne Shire Council, Port Fairy Office, Princes Street, Port Fairy.

ADRIAN SALMON

Co-ordinator, Amendment Services  
Local Government, Planning and  
Market Information Services Division  
Department of Infrastructure

**Planning and Environment Act 1987****BERWICK PLANNING SCHEME**

## Notice of Approval of Amendment

## Amendment L129

The Minister for Planning and Local Government has approved Amendment L129 to the Berwick Planning Scheme.

The Amendment comes into operation on the date this notice is published in the Government Gazette.

The Amendment inserts a site specific control to the Table to Clause 139 - Easements

and Restrictions of the Local Section of the Berwick Planning Scheme for the removal of a restrictive covenant applying to land described as Lot 2, LP 71146 (Nos. 41-51) William Street, Berwick.

A copy of the Amendment can be inspected, free of charge, during office hours, at the Department of Infrastructure, Customer Service Centre, Upper Plaza, Nauru House, 80 Collins Street, Melbourne and at the offices of the Casey City Council, Princes Highway, Narre Warren.

ADRIAN SALMON  
Co-ordinator, Amendment Services  
Local Government, Planning and  
Market Information Services Division  
Department of Infrastructure

---

**Planning and Environment Act 1987**  
GLEN EIRA PLANNING SCHEME  
Notice of Approval of Amendment  
Amendment L27

The Minister for Planning and Local Government has approved Amendment L27 to the Glen Eira Planning Scheme.

The Amendment comes into operation on the date this notice is published in the Government Gazette.

The Amendment inserts a site specific control into the Residential C Zone in order to protect a number of significant trees at 21 Omama Road, Murrumbeena and to ensure future development of the site is limited to locations which do not interfere with the trees. The Amendment replaces interim tree controls introduced by Amendment L26 to the Glen Eira Planning Scheme which are due to lapse on 28 August, 1998.

A copy of the Amendment can be inspected, free of charge, during office hours, at the Department of Infrastructure, Customer Service Centre, Upper Plaza, Nauru House, 80 Collins Street, Melbourne and at the offices of the City of Glen Eira, corner of Glen Eira and Hawthorn Roads, Caulfield.

ADRIAN SALMON  
Co-ordinator, Amendment Services  
Local Government, Planning and  
Market Information Services Division  
Department of Infrastructure

---

**Planning and Environment Act 1987**  
GREATER DANDENONG PLANNING  
SCHEME

Notice of Approval of Amendment

Amendment L13

The Minister for Planning and Local Government has approved Amendment L13 to the Greater Dandenong Planning Scheme.

The Amendment comes into operation on the date this notice is published in the Government Gazette.

The Amendment rezones part of the former Dandenong North Service Reservoir Site (Lot 2 PS 336819U), off Hennessy Way, Dandenong North from existing Public Purposes - Melbourne and Metropolitan Board of Works to an Urban Residential 1 Zone.

A copy of the Amendment can be inspected, free of charge, during office hours, at the Department of Infrastructure, Customer Service Centre, Upper Plaza, Nauru House, 80 Collins Street, Melbourne and at the offices of the City of Greater Dandenong, 397-405 Springvale Road, Springvale, 39 Clow Street, Dandenong, and Shop A7 Parkmore Shopping Centre, Keysborough.

ADRIAN SALMON  
Co-ordinator, Amendment Services  
Local Government, Planning and  
Market Information Services Division  
Department of Infrastructure

---

**Planning and Environment Act 1987**  
KNOX PLANNING SCHEME

Notice of Approval of Amendment

Amendment L170

The Minister for Planning and Local Government has approved Amendment L170 to the Knox Planning Scheme.

The Amendment comes into operation on the date this notice is published in the Government Gazette.

The Amendment changes the provisions of Clause 105-5 of the Knox Planning Scheme by increasing the current gross floor area limit at the Rowville Lakes Shopping Centre, Rowville from 1710 square metres to 1795 square metres to facilitate the extension of a hairdressing salon at Shop 4.

A copy of the Amendment can be inspected, free of charge, during office hours, at the Department of Infrastructure, Customer Service Centre, Upper Plaza, Nauru House, 80 Collins Street, Melbourne and at the offices of the Knox City Council, 511 Burwood Highway, Wantirna South.

ADRIAN SALMON  
Co-ordinator, Amendment Services  
Local Government, Planning and  
Market Information Services Division  
Department of Infrastructure

---

**Planning and Environment Act 1987**

MELTON PLANNING SCHEME

Notice of Approval of Amendment

Amendment L75 Part 2

The Minister for Planning and Local Government has approved Amendment L75 Part 2 to the Melton Planning Scheme.

The Amendment comes into operation on the date this notice is published in the Government Gazette.

The Amendment introduces provisions into the Conservation A zone to allow land at 233-271 Melton-Gisborne Road, Toolern Vale to be subdivided into two lots and for each lot to be used for one detached dwelling, subject to permit and Section 173 agreement.

A copy of the Amendment can be inspected, free of charge, during office hours, at the Department of Infrastructure, Customer Service Centre, Upper Plaza, Nauru House, 80 Collins Street, Melbourne and at the offices of the Melton Shire Council, 232 High Street, Melton.

ADRIAN SALMON  
Co-ordinator, Amendment Services  
Local Government, Planning and  
Market Information Services Division  
Department of Infrastructure

---

**Planning and Environment Act 1987**

MELTON PLANNING SCHEME

Notice of Approval of Amendment

Amendment L84

The Minister for Planning and Local Government has approved Amendment L84 to the Melton Planning Scheme.

The Amendment comes into operation on the date this notice is published in the Government Gazette.

The Amendment expands (by including Lot 1 PS 300006R) the area of land subject to the provisions of the Restricted Business zone at the Melton Regional Shopping Centre, High Street, Melton.

A copy of the Amendment can be inspected, free of charge, during office hours, at the Department of Infrastructure, Customer Service Centre, Upper Plaza, Nauru House, 80 Collins Street, Melbourne and at the offices of the Melton Shire Council, 232 High Street, Melton.

ADRIAN SALMON  
Co-ordinator, Amendment Services  
Local Government, Planning and  
Market Information Services Division  
Department of Infrastructure

---

**Planning and Environment Act 1987**

SHERBROOKE PLANNING SCHEME

Notice of Approval of Amendment

Amendment L131

The Minister for Planning and Local Government has approved Amendment L131 to the Sherbrooke Planning Scheme.

The Amendment comes into operation on the date this notice is published in the Government Gazette.

The Amendment rezones land at 7 Alexander Avenue, Emerald from Landscape Protection Zone to Landscape Living Zone to allow the land to be subdivided into two lots, subject to the granting of a permit.

A copy of the Amendment can be inspected, free of charge, during office hours, at the Department of Infrastructure, Customer Service Centre, Upper Plaza, Nauru House, 80 Collins Street, Melbourne and at the offices of the Shire of Cardinia, at Henty Way, Pakenham.

ADRIAN SALMON  
Co-ordinator, Amendment Services  
Local Government, Planning and  
Market Information Services Division  
Department of Infrastructure

---



**Planning and Environment Act 1987**  
DONCASTER AND TEMPLESTOWE  
PLANNING SCHEME

Notice of Approval of Amendment

Amendment L130

The Minister for Planning and Local Government has approved Amendment L130 to the Doncaster and Templestowe Planning Scheme.

The Amendment comes into operation on the date this notice is published in the Government Gazette.

The Amendment affects land known as Lots 1 and 2, LP 20877, at 48 and 50 Parker Street, Templestowe. The Amendment rezones the land from part Residential C and part Proposed Road Widening to the State Section Mixed Use Zone. The rezoning will allow for an existing panel beating use to be redeveloped, subject to the grant of a planning permit.

A copy of the Amendment can be inspected, free of charge, during office hours, at the Department of Infrastructure, Customer Service Centre, Upper Plaza, Nauru House, 80 Collins Street, Melbourne and at the offices of the City of Manningham, 699 Doncaster Road, Doncaster.

ADRIAN SALMON  
Co-ordinator, Amendment Services  
Local Government, Planning and  
Market Information Services Division  
Department of Infrastructure

**Planning and Environment Act 1987**  
WHITTLESEA PLANNING SCHEME

Notice of Approval of Amendment

Amendment L161

The Minister for Planning and Local Government has approved Amendment L161 to the Whittlesea Planning Scheme.

The Amendment comes into operation on the date this notice is published in the Government Gazette.

The Amendment inserts new clauses into the controls of the Corridor C and Plenty Valley Red Gum Zones to enable a permit to be applied for the subdivision of land at 1785 Donnybrook Road, Woodstock into 2 lots and one house to be constructed on each lot.

A copy of the Amendment can be inspected, free of charge, during office hours, at the Department of Infrastructure, Customer Service Centre, Upper Plaza, Nauru House, 80 Collins Street, Melbourne and at the offices of the Whittlesea City Council, McDonalds Road, South Morang.

ADRIAN SALMON  
Co-ordinator, Amendment Services  
Local Government, Planning and  
Market Information Services Division  
Department of Infrastructure

**Planning and Environment Act 1987**  
YARRA RANGES PLANNING SCHEME

Notice of Approval of Amendment

Amendment L94

The Minister for Planning and Local Government has approved Amendment L94 to the Yarra Ranges Planning Scheme.

The Amendment comes into operation on the date this notice is published in the Government Gazette.

The Amendment replaces the existing controls applying to the Burnham Beeches Estate, Sherbrooke Road, Sherbrooke, with new controls which will allow its redevelopment as a residential hotel, restaurant, function centre and other uses subject to the grant of a permit.

A copy of the Amendment can be inspected, free of charge, during office hours, at the Department of Infrastructure, Customer Service Centre, Upper Plaza, Nauru House, 80 Collins Street, Melbourne and at the offices of the Yarra Ranges Shire Council, Anderson Street, Lilydale.

ADRIAN SALMON  
Co-ordinator, Amendment Services  
Local Government, Planning and  
Market Information Services Division  
Department of Infrastructure

**Planning and Environment Act 1987**  
YARRA RANGES PLANNING SCHEME

Notice of Lapsing of Amendment

Amendment L90

The Yarra Ranges Shire Council has resolved to abandon Amendment L90 to the Yarra Ranges Planning Scheme.

1652 G 25 25 June 1998

*Victoria Government Gazette*

The Amendment proposed to introduce discretion into the Sherbrooke Chapter of the Planning Scheme to enable Council to consider an application for planning permit to use land at 18 Matson Drive, Upwey for a Place of Worship.

The Amendment lapsed on 8 May 1998.

ADRIAN SALMON  
Co-ordinator, Amendment Services  
Local Government, Planning and  
Market Information Services Division  
Department of Infrastructure

---

**ORDERS IN COUNCIL****Cemeteries Act 1958**

## SCALE OF FEES

In pursuance of the powers conferred upon them by the **Cemeteries Act 1958** the trustees of the Yallourn Public Cemetery hereby make the following scale of fees which shall come into operation on publication in the Government Gazette.

As of the date of gazettal of the fees listed below, all other previously gazetted fees for the Yallourn Public Cemetery are rescinded to the extent to which they conflict with this scale.

\$

Sinking graves for interment on Saturdays, Sundays and Public Holidays:  
Double normal rate.

IRENE C. HALL, trustee  
N. G. FOLEY, trustee  
R. HARVEY, trustee

Dated 19 May 1998

Responsible Minister:  
ROB KNOWLES  
Minister for Health

SHARNE BRYAN  
Clerk of the Executive Council

**Taxation (Reciprocal Powers) Act 1987**

## ORDER UNDER SECTION 3A(1)

1. The Governor in Council, acting under Section 3A(1) of the **Taxation (Reciprocal Powers) Act 1987** ("the Act") declares that:-

- (a) a law specified in column 2 of the Table opposite a State Taxation Act specified in column 1 of the Table is a declared revenue law for the purposes of the Act in relation to that State Taxation Act; and
- (b) an office specified in column 3 of the Table under a law specified in column 2 of the Table opposite that office is a declared office for the purposes of the Act in relation to the office of State Commissioner under the State Taxation Act specified in column 1 of the Table opposite that office.

TABLE

Column 1 State Taxation Act	Column 2 Corresponding Laws	Column 3 Corresponding Offices
Business Franchise (Petroleum Products) Act 1979	Fuel Subsidy Act 1997 (Qld)	Commissioner of Stamp Duties

Dated 23 June 1998

Responsible Minister:  
ALAN R. STOCKDALE  
Treasurer

SHARNE BRYAN  
Clerk of the Executive Council

**Health Services Act 1988**

AMALGAMATION OF WEST WIMMERA HEALTH SERVICE AND GOROKE  
COMMUNITY HEALTH CENTRE INCORPORATED  
TO BE KNOWN AS WEST WIMMERA HEALTH SERVICE

The Governor in Council acting on the recommendation of the Minister for Health made after receiving advice from the delegate of the Secretary to the Department of Human Services under section 64A of the **Health Services Act 1988** ("the Act"), and acting under section 65 of that Act, by this Order:-

1. **Directs** under section 65(1) of the Act, that West Wimmera Health Service and Goroke Community Health Centre Incorporated be amalgamated;
2. **Specifies** under section 65(2) of the Act, 1 July 1998 as the date that:-
  - (a) the incorporation of each of West Wimmera Health Service and Goroke Community Health Centre Incorporated, each being registered funded agencies under the **Health Services Act 1988**, shall be cancelled; and
  - (b) a new registered funded agency, to be known as West Wimmera Health Service, comes into existence, as if on that date it had been incorporated under the **Health Services Act 1988**; and
  - (c) the initial board of management of West Wimmera Health Service shall be constituted as specified in the table below and appointed for the terms as specified below:

<b>MEMBERS OF THE BOARD OF MANAGEMENT:</b>	
STEWART, Maurice Anthony	until 31 October 1999
GAWITH, Peter William	until 31 October 1999
FEDER, Jeannette Anne	until 31 October 1999
CLARKE, Leonie Gae	until 31 October 1999
HOBDAY, Dianne Maree	until 31 October 2000
SIBSON, Graeme George	until 31 October 2000
ISMAY, Ronald Arthur	until 31 October 2000
WALTER, Ruth Alison	until 31 October 2000
HARRIS, Digby Ian	until 30 June 2001
MAGRATH, John Robert	until 30 June 2001
LEYONHJELM, Josephine Winfield	until 30 June 2001
KLEMM, Brian Leonard	until 30 June 2001

3. **Orders** under section 65(3) of the Act that:-
  - (a) the by-laws of West Wimmera Health Service shall be the by-laws approved by the delegate of the Secretary on 4 June 1998 with effect from 1 July 1998 and as altered by West Wimmera Health Service from time to time in accordance with the **Health Services Act 1988**; and
  - (b) the objects of West Wimmera Health Service shall be the objects approved by the delegate of the Secretary on 4 June 1998 with effect from 1 July 1998 and as altered by West Wimmera Health Service from time to time in accordance with the **Health Services Act 1988**;

4. **Declares** under section 65(4) of the Act, that the new registered funded agency named West Wimmera Health Service shall be a public hospital;

to take effect from 1 July 1998.

Dated 23 June 1998.

Responsible Minister:  
ROB KNOWLES  
Minister for Health

SHARNE BRYAN  
Clerk of the Executive Council

### Health Services Act 1988

#### AMALGAMATION OF MT ALEXANDER HOSPITAL AND MOUNT ALEXANDER HOSTELS INCORPORATED

#### TO BE KNOWN AS MT ALEXANDER HOSPITAL

The Governor in Council acting on the recommendation of the Minister for Health made after receiving advice from the delegate of the Secretary to the Department of Human Services under section 64A of the **Health Services Act 1988** ("the Act"), and acting under section 65 of that Act, by this Order:-

1. **Directs** under section 65(1) of the Act, that Mt Alexander Hospital and Mount Alexander Hostels Incorporated be amalgamated;
2. **Specifies** under section 65(2) of the Act, 1 July 1998 as the date that:-
  - (a) the incorporation of each of Mt Alexander Hospital and Mt Alexander Hostels Incorporated, each being registered funded agencies under the **Health Services Act 1988**, shall be cancelled; and
  - (b) a new registered funded agency, to be known as Mt Alexander Hospital, comes into existence, as if on that date it had been incorporated under the **Health Services Act 1988**; and
  - (c) the initial board of management of Mt Alexander Hospital shall be constituted as specified in the table below and appointed for the terms as specified below:

<b>MEMBERS OF THE BOARD OF MANAGEMENT:</b>	
CARTHEW, William Stephen	until 31 October 1998
CAESAR-GORDON, Francis	until 31 October 1998
GERNHOEFER, Ian Neil	until 31 October 1998
O'DONNELL, Michael William	until 31 October 1998
FITZGERALD, Leslie Robert	until 31 October 1999
GILBERT, Ivan Leslie	until 31 October 1999
RICHMOND, Georgia Page	until 31 October 1999
VAN GEMERT, Johannes Theodorus	until 31 October 1999
CURWEN-WALKER, Henry Cleburne	until 31 October 2000
HOWE, Jennifer Mary	until 31 October 2000
SHAY, Barry Douglas	until 31 October 2000
STEPHENS, Angela Elizabeth	until 31 October 2000

3. **Orders** under section 65(3) of the Act that:-

- (a) the by-laws of Mt Alexander Hospital shall be the by-laws approved by the delegate of the Secretary on 21 May 1998 with effect from 1 July 1998 and as altered by Mt Alexander Hospital from time to time in accordance with the **Health Services Act 1988**; and
- (b) the objects of Mt Alexander Hospital shall be the objects approved by the delegate of the Secretary on 21 May 1998 with effect from 1 July 1998 and as altered by Mt Alexander Hospital from time to time in accordance with the **Health Services Act 1988**;

4. **Declares** under section 65(4) of the Act, that the new registered funded agency named Mt Alexander Hospital shall be a public hospital;

to take effect from 1 July 1998.

Dated 23 June 1998.

Responsible Minister:  
ROB KNOWLES  
Minister for Health

SHARNE BRYAN  
Clerk of the Executive Council

**Health Services Act 1988**

AMALGAMATION OF HAMILTON BASE HOSPITAL AND PENSHURST AND DISTRICT  
MEMORIAL HOSPITAL

TO BE KNOWN AS WESTERN DISTRICT HEALTH SERVICE

The Governor in Council acting on the recommendation of the Minister for Health made after receiving advice from the delegate of the Secretary to the Department of Human Services under section 64A of the **Health Services Act 1988** ("the Act"), and acting under section 65 of that Act, by this Order:-

1. **Directs** under section 65(1) of the Act, that Hamilton Base Hospital and Peshurst and District Memorial Hospital be amalgamated;
2. **Specifies** under section 65(2) of the Act, 1 July 1998 as the date that:-
  - (a) the incorporation of each of Hamilton Base Hospital and Peshurst and District Memorial Hospital, each being registered funded agencies under the **Health Services Act 1988**, shall be cancelled; and
  - (b) a new registered funded agency, to be known as Western District Health Service, comes into existence, as if on that date it had been incorporated under the **Health Services Act 1988**; and
  - (c) the initial board of management of Western District Health Service shall be constituted as specified in the table below and appointed for the terms as specified below:

<b>MEMBERS OF THE BOARD OF MANAGEMENT:</b>	
GREIG, Robert Peter	until 31 October 2000
KOCH, David Frank	until 31 October 2000
SANDOW, Peter John	until 31 October 2000
WALTER, Richard Dennis	until 31 October 2000
DEAN, John Nicholas	until 31 October 1999

HALLMARK, Karin Cecily	until 31 October 1999
MORTON, Rebecca Elizabeth	until 31 October 1999

3. **Orders** under section 65(3) of the Act that:-
  - (a) the by-laws of Western District Health Service shall be the by-laws approved by the delegate of the Secretary on 11 June 1998 with effect from 1 July 1998 and as altered by Western District Health Service from time to time in accordance with the **Health Services Act 1988**; and
  - (b) the objects of Western District Health Service shall be the objects approved by the delegate of the Secretary on 11 June 1998 with effect from 1 July 1998 and as altered by Western District Health Service from time to time in accordance with the **Health Services Act 1988**;
4. **Declares** under section 65(4) of the Act, that the new registered funded agency named Western District Health Service shall be a public hospital;
5. **Amends** pursuant to section 8(1)(a) and (b) of the Act, Schedule 1 by:
  - (a) removing the name of "Hamilton Base Hospital";
  - (b) removing the name of "Penshurst and District Memorial Hospital"; and
  - (c) adding the name of "Western District Health Service";

to take effect from 1 July 1998.

Dated 23 June 1998.

Responsible Minister:  
ROB KNOWLES  
Minister for Health

SHARNE BRYAN  
Clerk of the Executive Council

### **Vocational Education and Training Act 1990**

#### **CHISHOLM INSTITUTE OF TECHNICAL AND FURTHER EDUCATION ORDER 1998**

The Governor in Council makes the following order:

#### **1. Objective**

The objective of this order is to abolish the Barton Institute of Technical and Further Education, the Casey Institute of Technical and Further Education and the Peninsula Institute of Technical and Further Education and to create a new Institute to be called the "Chisholm Institute of Technical and Further Education".

#### **2. Authorising provision**

This Order is made under section 23(1) of the **Vocational Education and Training Act 1990** on the recommendation of the Minister for Tertiary Education and Training made in accordance with that section.

#### **3. Commencement**

This Order takes effect on 1 July 1998.

#### **4. Abolition of Barton, Casey and Peninsula Institutes of Technical and Further Education and creation of Chisholm Institute of Technical and Further Education**

- (1) The Barton Institute of Technical and Further Education, the Casey Institute of Technical and Further Education, and the Peninsula Institute of Technical and Further Education are abolished.
- (2) An Institute called the "Chisholm Institute of Technical and Further Education" is created.
- (3) Schedule 1 to the **Vocational Education and Training Act 1990** is amended:-
  - (i) by removing "Barton Institute of Technical and Further Education", "Casey Institute of Technical and Further Education", and "Peninsula Institute of Technical and Further Education"; and

- (ii) by inserting "Chisholm Institute of Technical and Further Education".

**5. Students**

On the day this Order takes effect:

- (a) subject to paragraph (b) of this clause 5, a person who was, immediately prior to 1 July 1998, an enrolled student of a Former Institute is an enrolled student of the Chisholm Institute of Technical and Further Education; and
- (b) a person who was, immediately prior to 1 July 1998, an enrolled student of the Barton Institute of Technical and Further Education enrolled in a program referred to, or a Traineeship Program listed, in Schedule One is an enrolled student of the Kangan Batman Institute of Technical and Further Education.

**6. Meaning of Terms**

'Former Institute' means the Barton Institute of Technical and Further Education, the Casey Institute of Technical and Further Education and the Peninsula Institute of Technical and Further Education;

'Kangan Batman Institute of Technical and Further Education' means the Kangan Batman Institute of Technical and Further Education formed by clause 4(1) of the Kangan Batman Institute of Technical and Further Education Order 1997 made on 3 June 1997.

**Schedule One**

1. Automotive programs subject to the 1998 Performance Agreement between the State Training Board of Victoria and the Council of Barton Institute of Technical and Education pursuant to section 10 of the Vocational Education and Training Act 1990.

2. Traineeship Programs:

- NT1211 Cert. II in Auto (Accessory Fitting)
- NT2004 Cert. II in Auto (Panel Beating Services)
- NT2628 Cert. II in Auto (Paint Services)
- 2206AGB Cert. II in Auto (Cylinder Heads)
- NT1214 Cert. II in Auto (Exhaust Services)
- NT1216 Cert. II in Auto (Replacement Parts)
- NT1213 Cert. II in Auto (Tyre Services)
- NT1215 Cert. II in Auto (Vehicle Detailing)
- NT1212 Cert. II in Auto (Vehicle Dismantling)
- NT1217 Cert. II in Auto (Radiator Services)
- NT1224 Cert. In Automotive Glazing

NT2629 Cert. II in Auto (Brake & Underbody Services)

Dated 23 June 1998.

Responsible Minister:  
 PHIL HONEYWOOD MP  
 Minister for Tertiary Education and Training  
 SHARNE BRYAN  
 Clerk of the Executive Council

**Land Act 1958**

**UNUSED ROAD CLOSED**

The Governor in Council under Section 349 of the Land Act 1958, and with the consent in writing of the municipality concerned and the adjoining owner closes the following portions of unused road;

**MUNICIPAL DISTRICT OF THE  
 LA TROBE SHIRE COUNCIL**

**NARRACAN** — The portions of road in the Parish of Narracan as indicated by hatching on plan hereunder. — (LVMT019) (L10-5571).

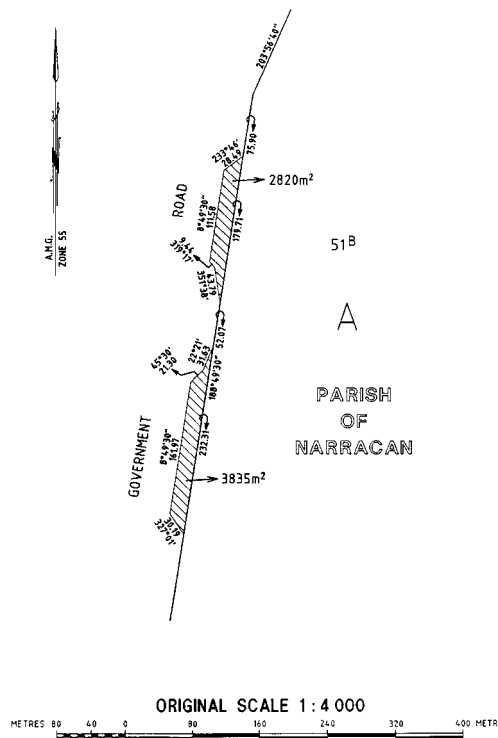

This Order is effective from the date on which it is published in the Victoria Government Gazette.



Dated 23 June 1998

Responsible Minister:  
MARIE TEHAN  
Minister for Conservation and Land  
Management

SHARNE BRYAN  
Clerk of the Executive Council

**State Owned Enterprises Act 1992**

DECLARATION OF DECLARED BUSINESS  
ENTERPRISES UNDER SECTION 88B

Order in Council

The Governor in Council acting under  
Section 88B(8) of the **State Owned  
Enterprises Act 1992** declares the following  
statutory corporations to be declared business  
enterprises for the purposes of section 88B of  
that Act with effect from 1 July 1998:-

Victorian Plantations Corporation  
Victorian Channels Authority  
Urban Land Corporation  
Transport Accident Commission  
Melbourne Water Corporation

Dated 23 June 1998

Responsible Minister:  
ALAN R. STOCKDALE  
Treasurer

SHARNE BRYAN  
Clerk of the Executive Council

**Public Sector Management and Employment  
Act 1998**

ESTABLISHMENT OF DEPARTMENTS  
AND ADMINISTRATIVE OFFICES

Pursuant to Sections 10 and 11 of the **Public  
Sector Management and Employment Act  
1998**, the Governor in Council establishes the  
Departments listed in Column 1 of the Schedule  
to this Order and establishes, in relation to  
certain of those Departments, the Administrative  
Offices listed in Column 2 of that Schedule.

This Order operates from 1 July 1998.

**SCHEDULE**

**DEPARTMENTS AND ADMINISTRATIVE  
OFFICES**

Column 1	Column 2
<b>Department</b>	<b>Administrative Office</b>
Department of Education	
Department of Human Services	
Department of Infrastructure	
Department of Justice	Office of the Victorian Government Solicitor
Department of Natural Resources and Environment	Environment Protection Authority
Department of Premier and Cabinet	Office of the Governor
	Office of the Chief Parliamentary Counsel
Department of State Development	
Department of Treasury and Finance	

Dated 23 June 1998

Responsible Minister:  
J. G. KENNETT  
Premier

SHARNE BRYAN  
Clerk of the Executive Council

**Water Industry Act 1994**

ORDER VARYING THE WATER AND  
SEWERAGE LICENCE ISSUED TO SOUTH  
EAST WATER LTD

**RECITALS**

- A. The Governor in Council issued a water and sewerage licence ("the licence") to South East Water Ltd, A.C.N. 066 902 547, on 22 December 1994.
- B. Section 14(1)(a) of the **Water Industry Act 1994** provides that a licence or the licence conditions may be varied in accordance with the procedures specified in the licence conditions. Clause 20 of the licence enables the Governor in Council, by Order, to vary the licence following

consultation between the Minister, the licensee and the Office of the Regulator-General.

- C. Consultation has occurred between the Minister, the licensee and the Office of the Regulator-General.

**NOW THEREFORE**, the Governor in Council, acting under clause 20 of the licence, **VARIES THE LICENCE AS FOLLOWS:-**

**1. Term of Licence**

In Part A of the licence, for the term of the licence **substitute** -

“This licence operates from 1 January 1995 to 30 June 1999.”

**2. Serviced properties**

**Omit** clauses 3A and 3B of the licence

**3. Backlog sewerage**

After clause 3 of the licence **insert** -

**“3C Backlog sewerage**

3C.1 In respect of the period 1 July 1998 to 30 June 1999 the licensee must undertake a program of works for the provision of sewerage services to unsewered urban areas which is consistent with a two year plan approved by the Minister after consultation with the Treasurer.”

**4. Collection of Melbourne Parks and Waterways Rates**

- 4.1 In sub-clause 6.3 of the licence for “The fee payable under sub-clause 6.2 and 6.3” **substitute** “The fee payable under sub-clauses 6.1 and 6.2”.

- 4.2 After sub-clause 6.3 of the licence **insert** -

“6.3AA Subject to sub-clause 6.3AB, the fee payable under sub-clauses 6.1 and 6.2 as adjusted must be further adjusted on 1 July 1998 in accordance with the following formula:

$$F = A \times B/C$$

Where:

F means the fee payable on or after 1 July 1998;

A means the fee payable before 1 July 1998;

B means the CPI at 1 July 1998; and

C means the CPI at 1 January 1997.

- 6.3AB The licensee and Melbourne Parks and Waterways may agree to a different fee for the services provided under this clause.”.

- 4.3 In sub-clause 6.3A of the licence, for “the formula in sub-clause 6.3.” **substitute** “the formula in sub-clauses 6.3 and 6.3AA.”

**5. Implied customer contract**

For sub-clause 7.3 of the licence **substitute** -

“The licensee must develop and implement procedures to consult with customers about the content of the implied customer contract and must by 30 September in each year or such date as agreed by the Office and licensee submit to the Office proposed revisions to that contract arising as a result of its consultation with customers.”

**6. Confidentiality**

**Omit** sub-clause 7A.2 of the licence.

**7. Water quality monitoring**

For sub-clause 8B.2 of the licence **substitute** -

“8B.2 The licensee must prepare and make publicly available a report of the results of its water quality monitoring program for the preceding financial year in accordance with Guidelines issued by the Office. The report must present the results for each supply zone described in Map A1 of Attachment 1 of the customer contract in Schedule 1 and include the number of samples taken.”

**8. Security Deposits**

- 8.1 In the heading to clause 9 of the licence, for “**Fees, Prices and Charges**” **substitute** “**Security Deposits**”.

- 8.2 **Omit** sub-clauses 9.1 and 9.2 of the licence.

**9. Business methods or principles**

For sub-clause 12.3 of the licence **substitute** -

“12.3 Sub-clause 12.2 is to be read subject to the Pricing Order.”

**10. Other services**

10.1 In the heading to clause 18 of the licence for "**Community service obligations and other services**" substitute "**Other services**".

10.2 **Omit** sub-clauses 18.1, 18.2, 18.3 and 18.5 of the licence.

**11. Procedures relating to variation**

**Omit** sub-clause 20.2 of the licence.

**12. Schedule 3 - Regulated Fees, Prices and Charges**

**Omit** Schedule 3 of the licence.

**13. Commencement**

This Order comes into operation on 1 July 1998.

Dated 23 June 1998

Responsible Minister:

PATRICK McNAMARA

Minister for Agriculture and Resources

SHARNE BRYAN

Clerk of the Executive Council

**Water Industry Act 1994**

ORDER VARYING THE WATER AND  
SEWERAGE LICENCE ISSUED TO YARRA  
VALLEY WATER LTD

**RECITALS**

A. The Governor in Council issued a water and sewerage licence ("the licence") to Yarra Valley Water Ltd, A.C.N. 066 902 501, on 22 December 1994.

B. Section 14(1)(a) of the **Water Industry Act 1994** provides that a licence or the licence conditions may be varied in accordance with the procedures specified in the licence conditions. Clause 20 of the licence enables the Governor in Council, by Order, to vary the licence following consultation between the Minister, the licensee and the Office of the Regulator-General.

C. Consultation has occurred between the Minister, the licensee and the Office of the Regulator-General.

**NOW THEREFORE**, the Governor in Council, acting under clause 20 of the licence, **VARIES THE LICENCE AS FOLLOWS:-**

**1. Term of Licence**

In Part A of the licence, for the term of the licence **substitute -**

"This licence operates from 1 January 1995 to 30 June 1999."

**2. Area**

In Part B of the licence, for the area **substitute -**

"The areas covered by this licence are:- insofar as the licence relates to water supply services, the area delineated on the plans numbered LEGL./94 96-106, LEGL./110-136 and LEGL./98 18-22 lodged in the Central Plan Office, and insofar as the licence relates to sewerage services, the area delineated on the plans numbered LEGL./94 138-148, LEGL./94 152-178 and LEGL./98 23-27 lodged in the Central Plan Office."

**3. Serviced properties**

**Omit** clauses 3A and 3B of the licence

**4. Backlog sewerage**

After clause 3 of the licence **insert -**

**"3C Backlog sewerage**

3C.1 In respect of the period 1 July 1998 to 30 June 1999 the licensee must undertake a program of works for the provision of sewerage services to unsewered urban areas which is consistent with a two year plan approved by the Minister after consultation with the Treasurer."

**5. Collection of Melbourne Parks and Waterways Rates**

5.1 In sub-clause 6.3 of the licence for "The fee payable under sub-clause 6.2 and 6.3" **substitute** "The fee payable under sub-clauses 6.1 and 6.2".

5.2 After sub-clause 6.3 of the licence **insert -**

"6.3AA Subject to sub-clause 6.3AB, the fee payable under sub-clauses 6.1 and 6.2 as adjusted must be further adjusted on 1 July 1998 in accordance with the following formula:

$$F = A \times B/C$$

Where:

F means the fee payable on or after 1 July 1998;

A means the fee payable before 1 July 1998;

B means the CPI at 1 July 1998; and

C means the CPI at 1 January 1997.

6.3AB The licensee and Melbourne Parks and Waterways may agree to a different fee for the services provided under this clause.”

5.3 In sub-clause 6.3A of the licence, for “the formula in sub-clause 6.3.” **substitute** “the formula in sub-clauses 6.3 and 6.3AA.”

#### 6. Implied customer contract

For sub-clause 7.3 of the licence **substitute** -

“The licensee must develop and implement procedures to consult with customers about the content of the implied customer contract and must by 30 September in each year or such date as agreed by the Office and licensee submit to the Office proposed revisions to that contract arising as a result of its consultation with customers.”

#### 7. Confidentiality

**Omit** sub-clause 7A.2 of the licence.

#### 8. Water quality monitoring

For sub-clause 8B.2 of the licence **substitute** -

“8B.2 The licensee must prepare and make publicly available a report of the results of its water quality monitoring program for the preceding financial year in accordance with Guidelines issued by the Office. The report must present the results for each supply zone described in Map A1 of Attachment 1 of the customer contract in Schedule 1 and include the number of samples taken.”

#### 9. Security Deposits

9.1 In the heading to clause 9 of the licence, for “**Fees, Prices and Charges**” **substitute** “**Security Deposits**”.

9.2 **Omit** sub-clause 9.1 and sub-clause 9.2 of the licence.

#### 10. Business methods or principles

For sub-clause 12.3 of the licence **substitute** -

“12.3 Sub-clause 12.2 is to be read subject to the Pricing Order.”

#### 11. Other services

11.1 In the heading to clause 18 of the licence for “**Community service obligations and other services**” **substitute** “**Other services**”.

11.2 **Omit** sub-clauses 18.1, 18.2, 18.3 and 18.5 of the licence.

#### 12. Procedures relating to variation

**Omit** sub-clause 20.2 of the licence.

#### 13. Schedule 3 - Regulated Fees, Prices and Charges

**Omit** Schedule 3 of the licence.

#### 14. Commencement

This Order comes into operation on 1 July 1998.

Dated 23 June 1998

Responsible Minister:

PATRICK McNAMARA

Minister for Agriculture and Resources

SHARNE BRYAN

Clerk of the Executive Council

### Water Industry Act 1994

#### ORDER VARYING THE WATER AND SEWERAGE LICENCE ISSUED TO CITY WEST WATER LTD

#### RECITALS

A. The Governor in Council issued a water and sewerage licence (“the licence”) to City West Water Ltd, A.C.N. 066 902 467, on 22 December 1994.

B. Section 14(1)(a) of the **Water Industry Act 1994** provides that a licence or the licence conditions may be varied in accordance with the procedures specified in the licence conditions. Clause 20 of the licence enables the Governor in Council, by Order, to vary the licence following consultation between the Minister, the licensee and the Office of the Regulator-General.

C. Consultation has occurred between the Minister, the licensee and the Office of the

Regulator-General.

**NOW THEREFORE**, the Governor in Council, acting under clause 20 of the licence, **VARIES THE LICENCE AS FOLLOWS:-**

**1. Term of licence**

In Part A of the licence, for the term of the licence **substitute** -

“This licence operates from 1 January 1995 to 30 June 1999.”

**2. Area**

In Part B of the licence, for

“insofar as the licence relates to water supply services, the area delineated on the plans numbered LEGL./94 44-69, lodged in the Central Plan Office, and”

**substitute** -

“insofar as the licence relates to water supply services, the area delineated on the plans numbered LEGL./94 44-69 and LEGL./98 34-36 lodged in the Central Plan Office, and”.

**3. Serviced properties**

**Omit** clauses 3A and 3B of the licence

**4. Collection of Melbourne Parks and Waterways Rates**

4.1 In sub-clause 6.3 for “The fee payable under sub-clauses 6.2 and 6.3” **substitute** “The fee payable under sub-clauses 6.1 and 6.2”.

4.2 After sub-clause 6.3 of the licence **insert** -

“6.3AA Subject to sub-clause 6.3AB, the fee payable under sub-clauses 6.1 and 6.2 as adjusted must be further adjusted on 1 July 1998 in accordance with the following formula:

$$F = A \times B/C$$

Where:

F means the fee payable on or after 1 July 1998;

A means the fee payable before 1 July 1998;

B means the CPI at 1 July 1998; and

C means the CPI at 1 January 1997.

6.3AB The licensee and Melbourne

Parks and Waterways may agree to a different fee for the services provided under this clause.”.

4.3 In sub-clause 6.3A, for “the formula in sub-clause 6.3.” **substitute** “the formula in sub-clauses 6.3 and 6.3AA.”.

**5. Implied customer contract**

For sub-clause 7.3 of the licence **substitute** -

“The licensee must develop and implement procedures to consult with customers about the content of the implied customer contract and must by 30 September in each year or such date as agreed by the Office and licensee submit to the Office proposed revisions to that contract arising as a result of its consultation with customers.”.

**6. Confidentiality provisions**

**Omit** sub-clause 7A.2 of the licence.

**7. Water quality monitoring**

For sub-clause 8B.2 of the licence **substitute** -

“8B.2 The licensee must prepare and make publicly available a report of the results of its water quality monitoring program for the preceding financial year in accordance with Guidelines issued by the Office. The report must present the results for each supply zone described in Map A1 of Attachment 1 of the customer contract in Schedule 1 and include the number of samples taken.”

**8. Security Deposits**

8.1 In the heading to clause 9 of the licence, for “**Fees, Prices and Charges**” **substitute** “**Security Deposits**”.

8.2 **Omit** sub-clauses 9.1 and 9.2 of the licence.

**9. Business methods or principles**

For sub-clause 12.3 of the licence **substitute** -

“12.3 Sub-clause 12.2 is to be read subject to the Pricing Order.”

**10. Other services**

10.1 In the heading to clause 18 of the licence for “**Community service obligations and**

other services” substitute “Other services”.

10.2 Omit sub-clauses 18.1, 18.2, 18.3 and 18.5 of the licence.

11. Procedures relating to variation

Omit sub-clause 20.2 of the licence.

12. Schedule 2 - Performance Standards

12.1 In Schedule 2 to the licence in the Standard of Drinking Water Quality, omit -  
 “• samples taken within a **Nominated Improvement Zone** prior to the date by which a Water Quality Program is to be completed within that Zone shall be excluded.”.

12.2 In Schedule 2 to the licence omit -

“ **“Nominated Improvement Zone”** is a nominated zone for a water quality improvement program as described in Attachment 1 of the customer contract contained in Schedule 1.”.

13. Schedule 3 - Regulated Fees, Prices and Charges

Omit Schedule 3 of the licence.

14. Commencement

This Order comes into operation on 1 July 1998.

Dated 23 June 1998

Responsible Minister:  
 PATRICK McNAMARA  
 Minister for Agriculture and Resources  
 SHARNE BRYAN  
 Clerk of the Executive Council

**Crown Land (Reserves) Act 1978**

NOTICE OF INTENTION

The Governor in Council under Section 10 of the **Crown Land (Reserves) Act 1978**, gives notice of intention to revoke the following temporary reservations to the extent indicated hereunder:

**BAIRNSDALE** — The temporary reservation by Order in Council of 26 November, 1941 of an area of 4.654 hectares of land in Section 80, Township of Bairnsdale, Parish of Bairnsdale as a site for a Benevolent Home, so far only as the portion containing 3.500 hectares as indicated by hatching on plan hereunder. — (B66[11]) (Rs 2256).

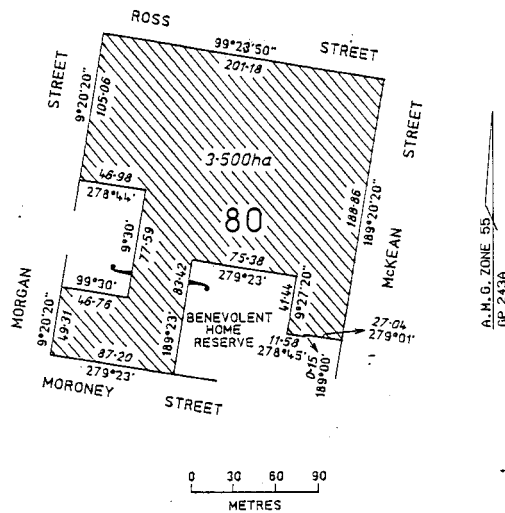

**BORHONEYGHURK** — The whole of the temporary reservation by Order in Council of 9 March, 1937 of an area of 2.155 hectares of land in the Parish of Borhoneyghurk as a site for public purposes. — (Rs 4659).

**CARALULUP** — The whole of the temporary reservation by Order in Council of 4 May 1914 of an area of 1.214 hectares of land in the Parish of Caralulup (formerly being part of Crown Allotment 36) as a site for a Night-Soil Depôt — (Rs 14178).

This Order is effective from the date on which it is published in the Victoria Government Gazette.

Dated 23 June 1998

Responsible Minister:  
 MARIE TEHAN  
 Minister for Conservation and Land Management

SHARNE BRYAN  
 Clerk of the Executive Council

**Crown Land (Reserves) Act 1978**

NOTICE OF INTENTION

The Governor in Council under Section 10 of the **Crown Land (Reserves) Act 1978**, gives notice of intention to revoke the following temporary reservation:

**BARWON DOWNS** — The temporary reservation by Order in Council of 18 November 1901 of an area of 1.361 hectares of land adjoining Crown Allotment 6E, Parish of

Barwon Downs as a site for Supply of Gravel. — (05/13665).

This Order is effective from the date on which it is published in the Victoria Government Gazette.

Dated 23 June 1998

Responsible Minister:

MARIE TEHAN

Minister for Conservation and Land Management

SHARNE BRYAN

Clerk of the Executive Council

---

**Crown Land (Reserves) Act 1978**

**REVOCATION OF TEMPORARY RESERVATIONS**

The Governor in Council under Section 10 of the **Crown Land (Reserves) Act 1978**, revokes the following temporary reservations to the extent indicated hereunder:

ASCOT — The whole of the temporary reservation by Order in Council of 8 April, 1867 of an area of 3.642 hectares of land in the Parish of Ascot (formerly part of Crown Allotment 89) as a site for Watering purposes. — (05/6850).

EVERTON — The whole of the temporary reservation by Order in Council of 25 August 1903 of an area of 1.983 hectares of land in Section 12, Parish of Everton as a site for Supply of Gravel. — (P200973).

KOO-WEE-RUP — The whole of the temporary reservation by Order in Council of 4 April, 1911 of an area of 2023 square metres of land in Section H, Parish of Koo-wee-rup, (formerly part of Crown Allotment 1, Section H) as a site for a Mechanics' Institute. — (Rs 3604).

KOO-WEE-RUP — The temporary reservation by Order in Council of 22 July 1908 of an area of 4.520 hectares of land in Section H, Parish of Koo-wee-rup, (formerly part of Crown Allotment 1, Section H) as a site for Public Recreation, revoked as to part by Order in Council of 7 March, 1911, so far as the balance remaining containing 4.318 hectares. — (Rs 6052)

KOO-WEE-RUP — The whole of the temporary reservation by Order in Council of 6 November, 1947 of an area of 8802 square metres of land in Section H, Parish of Koo-wee-

rup as a site for Public Recreation, in addition to and adjoining the site temporarily reserved therefor by Order in Council of 22 July, 1908. — (Rs 6052).

KOO-WEE-RUP — The whole of the temporary reservation by Order in Council of 26 January, 1993 of an area of 1.107 hectares of land being Crown Allotment 1L, Section H, Parish of Koo-wee-rup as a site for Public Recreation. — (Rs 6052).

LUCKNOW — The temporary reservation by Order in Council of 26 November, 1928 of an area of 5.760 hectares of land in two separate portions in the Township of Lucknow, Parish of Wy Yung as a site for Public Park, Recreation and Public Purposes, revoked as to part by Order in Council of 5 December, 1967, so far only as the portion containing 2250 square metres, more or less, as indicated by hatching on the plan published in the Victoria Government Gazette on 21 May, 1998 — page 1167. — (Rs 3789).

LUCKNOW — The temporary reservation by Order in Council of 4 March, 1958 of an area of 2.327 hectares, more or less, of land in the Township of Lucknow, Parish of Wy Yung as a site for Public Park, Recreation and Public purposes, in addition to and adjoining the site temporarily reserved therefor by Order in Council of 26 November, 1928, so far only as the portion containing 4320 square metres, more or less, as indicated by hatching on plan published in the Victoria Government Gazette on 21 May, 1998 — page 1168. — (Rs 3789).

WUK WUK — The whole of the temporary reservation by Order in Council of 23 November, 1885 of an area of 8094 square metres of land in the Parish of Wuk Wuk as a site for a State School. — (Rs 14255).

This Order is effective from the date on which it is published in the Victoria Government Gazette.

Dated 23 June 1998

Responsible Minister:

MARIE TEHAN

Minister for Conservation and Land Management

SHARNE BRYAN

Clerk of the Executive Council

---

**Crown Land (Reserves) Act 1978**  
**REVOCATION OF TEMPORARY**  
**RESERVATIONS**

The Governor in Council under Section 10 of the **Crown Land (Reserves) Act 1978**, revokes the following temporary reservations to the extent indicated hereunder:

**BALLARAT** — The whole of the temporary reservation by Order in Council of 29 June, 1869 of an area of 8084 square metres of land in Section T, Parish of Ballarat, (formerly being portion of the Village Reserve at the Springs, Parish of Bungaree) as a site for a Church of England Place of Public Worship. — (05/13661).

**BOGA** — The temporary reservation by Order in Council of 24 December, 1895 of an area of 62.726 hectares, more or less, of land in the Parish of Boga (formerly Parish of Boga [Lake Mannaor] as a site for Water Supply purposes, so far only as the portion containing 3600 square metres as indicated by hatching on plan published in the Victoria Government Gazette on 21 May, 1998 — page 1168. — (Rs 6042).

**BOGA** — The withholding from leasing or licensing by Order in Council of 10 June, 1879 of an area of 59.107 hectares of land in Section 3, Parish of Boga, so far only as the portion containing 3.641 hectares as indicated by hatching on plan published in the Victoria Government Gazette on 21 May, 1998 — page 1168. — (Rs 6042).

**PATHO** — The temporary reservation by Order in Council of 9 March, 1874 of an area of 210.437 hectares, more or less, of land in the Parish of Patho (formerly county of Gunbower) as a site for Watering purposes, revoked as to part by various Orders, so far only as the portion containing 1.370 hectares as indicated by hatching on plan published in the Victoria Government Gazette on 21 May, 1998 — page 1169. — (Rs 3143).

This Order is effective from the date on which it is published in the Victoria Government Gazette.

Dated 23 June 1998

Responsible Minister:  
 MARIE TEHAN  
 Minister for Conservation and Land  
 Management

SHARNE BRYAN  
 Clerk of the Executive Council

**Crown Land (Reserves) Act 1978**  
**CROWN LANDS TEMPORARILY**  
**RESERVED**

The Governor in Council under Section 4 of the **Crown Land (Reserves) Act 1978**, temporarily reserves the following Crown lands for the purposes mentioned:-

**MUNICIPAL DISTRICT OF THE**  
**BALLARAT CITY COUNCIL**

**BALLARAT EAST** — Public Recreation, 4190 square metres, more or less, being Crown Allotment 14B, Section 213, Township of Ballarat East, Parish of Ballarat as indicated by hatching on plan hereunder. — (B128[45]) — (Rs 21142).

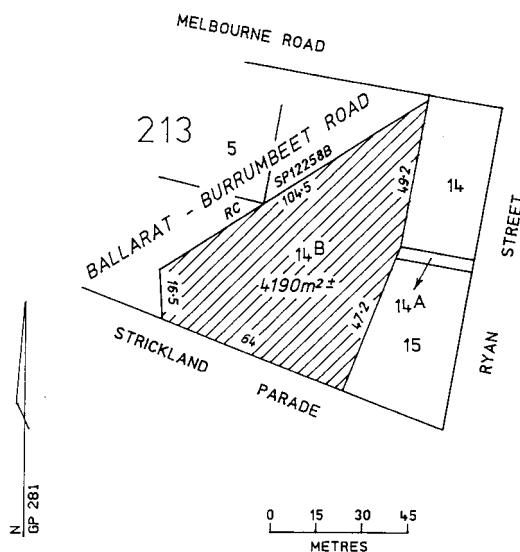

**MUNICIPAL DISTRICT OF THE**  
**HEPBURN SHIRE COUNCIL**

**CRESWICK** — Conservation of an area of natural interest, 7.879 hectares being Crown Allotment 41B, Section Q, Parish of Creswick as indicated by hatching on plan hereunder. — (C400[A13]) (Rs 12193).



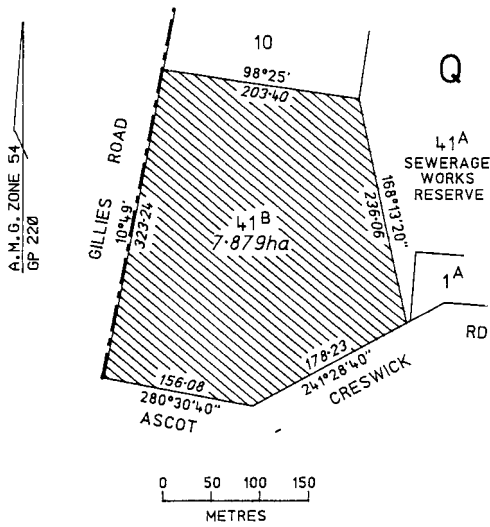

MUNICIPAL DISTRICT OF THE  
CORANGAMITE SHIRE COUNCIL

GLENORMISTON — Public Recreation, 2030 square metres being Subdivision 14A of Crown Allotment 4, Section 28, Parish of Glenormiston as shown in Certified Plan No. 107547 lodged in the Central Plan Office. — (L1-519).

MUNICIPAL DISTRICT OF THE  
GLENELG SHIRE COUNCIL

KINKELLA — Public Recreation and Hall, 8653 square metres, being Crown Allotments 1K and 1L, Parish of Kinkella as indicated by hatching on plan hereunder. — (K113[2]) (Rs 6674).

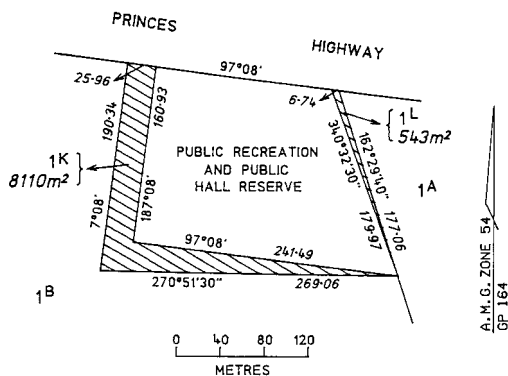

Total area of hatched portions 8653m<sup>2</sup>

This Order is effective from the date on which it is published in the Victoria Government Gazette.

Dated 23 June 1998

Responsible Minister:  
MARIE TEHAN  
Minister for Conservation and Land Management

SHARNE BRYAN  
Clerk of the Executive Council

Land Act 1958

UNUSED ROAD CLOSED

The Governor in Council under Section 349 of the **Land Act 1958**, and with the consent in writing of the municipality concerned closes the following unused road:

MUNICIPAL DISTRICT OF THE  
EAST GIPPSLAND SHIRE COUNCIL

TIDESLEY WEST — The road in the Parish of Tidesley West as indicated by hatching on plan hereunder. — (T276[8]) (P321281).

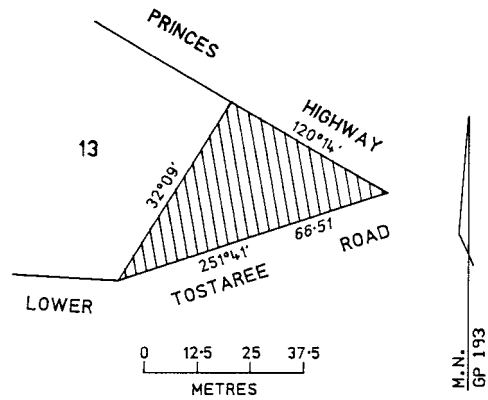

This Order is effective from the date on which it is published in the Victoria Government Gazette.

Dated 23 June 1998

Responsible Minister:  
MARIE TEHAN  
Minister for Conservation and Land Management

SHARNE BRYAN  
Clerk of the Executive Council

**Land Act 1958**  
**UNUSED ROADS CLOSED**

The Governor in Council under Section 349 of the **Land Act 1958** and with the consent in writing of the municipalities concerned and the adjoining owners closes the following unused roads:

**MUNICIPAL DISTRICT OF THE GREATER BENDIGO CITY COUNCIL**

**BENDIGO** — The road At Bendigo, Parish of Sandhurst shown as Crown Allotment 4A, Section 28B on Certified Plan No. 118529 lodged in the Central Plan Office. — (L6-10056)

**MUNICIPAL DISTRICT OF THE GREATER SHEPPARTON CITY COUNCIL**

**CONGUPNA** — The road in the Parish of Congupna shown as Crown Allotments 15J and 15K, Section B on Certified Plan No. 118727 lodged in the Central Plan Office. — (L8-5017).

**MUNICIPAL DISTRICT OF THE TOWONG SHIRE COUNCIL**

**GRANITE FLAT and MAGORRA** — The roads in the Township of Granite Flat and the Parish of Magorra as indicated by hatching on plan hereunder. — (M529[6] & G229[3]) (P204058).

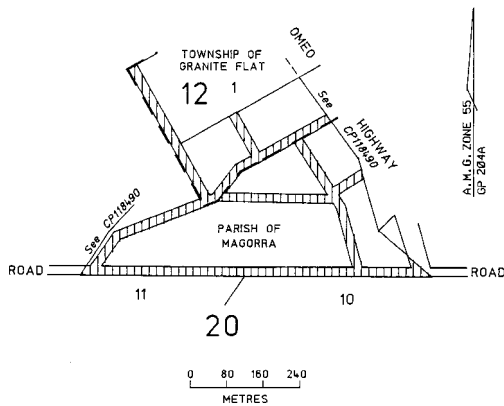

**MUNICIPAL DISTRICT OF THE STRATHBOGIE SHIRE COUNCIL**

**MONEA SOUTH** — The road in the Parish of Monea South shown as Crown Allotment 57C, Section 1 on Certified Plan No. 118676 lodged in the Central Plan Office. — (08/05295).

**MUNICIPAL DISTRICT OF THE WANGARATTA RURAL CITY COUNCIL**

**MURMUNGEE** — The road in the Parish of Murmungee as indicated by hatching on plan hereunder. — (3227[2] (L8-5669).

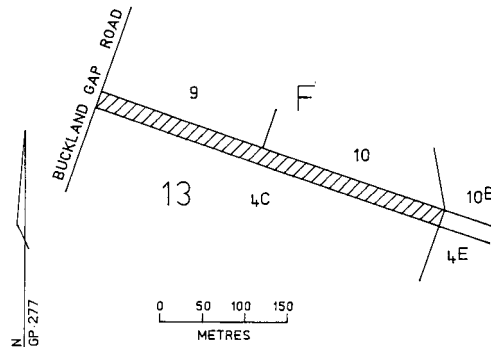

**MUNICIPAL DISTRICT OF THE ALPINE SHIRE COUNCIL**

**POREPUNKAH** — The road in the Parish of Porepunkah as indicated by hatching on plan hereunder. — (P70[A8]) (P203146).

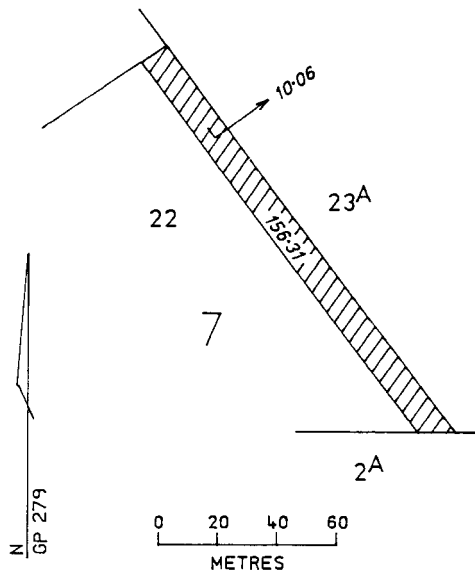

**MUNICIPAL DISTRICT OF THE BASS COAST SHIRE COUNCIL**

**WONTHAGGI** — The road in the Township of Wonthaggi, Parish of Wonthaggi shown as Crown Allotment 7A, Section 109 on Certified Plan No. 118686 lodged in the Central Plan Office. — (L12/0839).

This Order is effective from the date on which it is published in the Victoria Government Gazette.

Dated 23 June 1998

Responsible Minister:  
MARIE TEHAN

Minister for Conservation and Land Management

SHARNE BRYAN  
Clerk of the Executive Council

**Land Act 1958**

**AMENDMENT TO TOWNSHIP OF GRANITE FLAT**

The Governor in Council under Section 25(3)(d) of the **Land Act 1958** amends the Township of Granite Flat, proclaimed on 19 October, 1891 and diminished as to part by proclamations of 19 December, 1905; 24 September, 1912 and 15 June, 1920, by the excision therefrom of the area indicated by diagonal hatching on plan hereunder. — (G229[3]) (L8-4885).

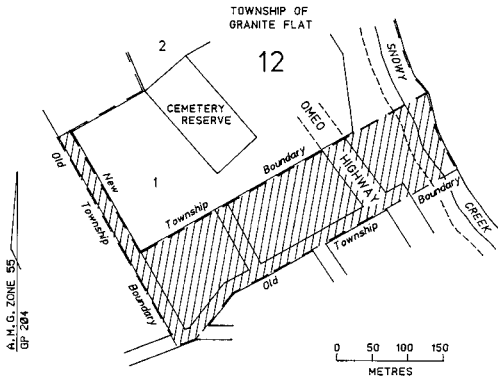

This Order is effective from the date on which it is published in the Victoria Government Gazette.

Dated 23 June 1998

Responsible Minister:  
MARIE TEHAN

Minister for Conservation and Land Management

SHARNE BRYAN  
Clerk of the Executive Council

VICTORIA

**State Aid to Religion Abolition Act 1871**

ACT NO. 391/1871 — SECOND SCHEDULE

A statement of trusts having been submitted by the head or authorised representative of the Roman Catholic Church for the Diocese of Ballarat under the provisions of the “Act to provide for the abolition of State Aid to Religion” for allowance by the Governor in Council, the same was allowed by him on the 23 June 1998, and the following is the form in which such statement of trusts has been allowed.

STATEMENT OF TRUSTS

DESCRIPTION OF LAND —

Site for Roman Catholic Place of Public Worship temporarily reserved on 13 September, 1869 being 3207 square metres, Township of Clarendon, Parish of Clarendon being Allotments 6 and 7, Section 6.

Commencing at the most southern angle of Allotment 5, Section 6 bounded thence by Allotments 15 and 16 bearing 138°58’ 50.29 metres; thence by Allotment 8 bearing 228°58’ 63.77 metres, and thence by the Midland Highway bearing 318°58’ 50.29 metres to the point of commencement.

NAME OF TRUSTEES —

The Roman Catholic Trusts Corporation for the Diocese of Ballarat.

POWERS OF DISPOSITION —

Such powers of disposition including powers of sale, lease or mortgage as are contained in the **Roman Catholic Trusts Act 1907**.

PURPOSES TOWARDS WHICH PROCEEDS OF DISPOSITION ARE TO BE APPLIED —

To such Roman Catholic Church purposes as shall be approved by the Trust.

This Order is effective from the date on which it is published in the Victoria Government Gazette.

Dated 23 June 1998

Responsible Minister:  
MARIE TEHAN

Minister for Conservation and Land Management

SHARNE BRYAN  
Clerk of the Executive Council

**SUBORDINATE LEGISLATION ACT 1994  
NOTICE OF MAKING OF STATUTORY  
RULES**

Notice is hereby given under Section 17 (2) of the **Subordinate Legislation Act 1994** of the making of the following Statutory Rules:

64. *Statutory Rule:* Audit (Public Bodies) (Amendment) Regulations 1998

*Authorising Act:* Audit Act 1994

*Date of making:* 23 June 1998

65. *Statutory Rule:* Road Safety (Vehicles) (Speeding Vehicles) Regulations 1998

*Authorising Act:* Road Safety Act 1986

*Date of making:* 23 June 1998

66. *Statutory Rule:* Transport Accident (Charges) (Amendment) Regulations 1998

*Authorising Act:* Transport Accident Act 1986

*Date of making:* 23 June 1998

67. *Statutory Rule:* Confiscation Regulations 1998

*Authorising Act:* Confiscation Act 1997

*Date of making:* 23 June 1998

68. *Statutory Rule:* Magistrates' Court General (Amendment) Regulations 1998

*Authorising Act:* Magistrates' Court Act 1989

*Date of making:* 23 June 1998

69. *Statutory Rule:* Subordinate Legislation (Appeal Costs Regulations 1988 - Extension of Operation) Regulations 1998

*Authorising Act:* Subordinate Legislation Act 1994

*Date of making:* 23 June 1998

70. *Statutory Rule:* Evidence (Affidavits and Statutory Declarations) Regulations 1998

*Authorising Act:* Evidence Act 1958

*Date of making:* 23 June 1998

**SUBORDINATE LEGISLATION ACT 1994  
NOTICE THAT STATUTORY RULES ARE  
OBTAINABLE**

Notice is hereby given under Section 17 (3) of the **Subordinate Legislation Act 1994** that the following Statutory Rules were first obtainable from Information Victoria, 356 Collins Street, Melbourne on the date specified:

63. *Statutory Rule:* Land Tax Regulations 1998  
*Authorising Act:* Land Tax Act 1958  
*Date first obtainable:* 23 June 1998  
*Code A*

Retail price will vary according to the number of pages in each special or periodical gazette. The table below sets out the prices that apply

<i>Price Code</i>	<i>No. of Pages (Including cover and blank pages)</i>	<i>Price</i>
A	1-16	\$2.90
B	17-32	\$4.30
C	33-48	\$5.90
D	49-96	\$9.15
E	97-144	\$11.85
F	145-192	\$14.00
G	193-240	\$16.15
H	241-288	\$17.20
I	289-352	\$19.35
J	353-416	\$22.60
K	417-430	\$25.80
L	431-544	\$30.10

**ADVERTISERS PLEASE NOTE**

As from 25 June 1998

The last Special Gazette was No. 61 dated 23 June 1998

The last Periodical Gazette was No. 1 dated 2 June 1998

## CONTENTS

	Page
Estates of Deceased Persons	1550
Government and Outer Budget Sector	
Agencies Notices	1561
Orders in Council—	1653
Acts — Cemeteries; Taxation (Reciprocal Powers); Health Services; Vocational Education and Training; Land; State Owned Enterprises; Public Sector Management and Employment; Water Industry; Crown Land (Reserves)	
Private Advertisements	1549
Proclamations	1511

The Victoria Government Gazette is published by The Craftsman Press Pty. Ltd. with the authority of the Government Printer for the State of Victoria  
© State of Victoria 1998

ISSN 0819-5471

This publication is copyright. No parts may be reproduced by any process except in accordance with the provisions of the Copyright Act.

Products and services advertised in this publication are not endorsed by The Craftsman Press Pty. Ltd. or the State of Victoria and neither of them accepts any responsibility for the content or the quality of reproduction. The Craftsman Press Pty. Ltd. reserves the right to reject any advertising material it considers unsuitable for government publication.

Address all inquiries to the Government Printer for the State of Victoria  
1 Macarthur Street  
Melbourne 3002 Victoria Australia

### RETAIL SALES

Information Victoria Bookshop  
356 Collins Street Melbourne 3000.  
Telephone enquiries 1300 366 356

City Graphics  
2nd Floor, 4 Bank Place  
Melbourne 3000

Telephone enquiries (03) 9600 0977

**Recommended Retail Price \$1.70**

*Government and Outer Budget Sector Agencies please note:*  
**STYLE REQUIREMENTS.**

To ensure that material received can be reproduced, and that errors are minimised, the following guidelines are to be observed when submitting material by fax.

**Fax resolution:**

Material sent by fax should be transmitted using Fine Resolution (200 dots per inch by 200 dpi).

**Font size:**

Use 12 point (10 pitch) or larger.

**Font Style:**

Clear plain font styles, such as Helvetica, should be used.

**Graphics:**

Line drawings should be transmitted as large as possible to ensure clarity. Drawings up to A4 size sent by fax using Fine Resolution provide a good quality for reproduction.

**Avoid:**

Italics, underlining and full justification.

Ensure document is square when sending as documents that are sent skewed are difficult to read and process.

ISSN 0819-5471

