



# Victoria Government Gazette

No. S 129 Thursday 14 June 2007  
By Authority, Victorian Government Printer

## Land Acquisition and Compensation Act 1986

### FORM 7

#### Notice of Acquisition

##### Compulsory Acquisition of Interest in Land

Central Highlands Region Water Authority, ABN 75 224 340 348, of 7 Learmonth Road, Ballarat, Vic. 3353 declares that by this notice it acquires the following interest in the land described in Certificate of Title Volume 10365, Folio 573 (“Land”).

An Easement for the purposes of a pipeline for water over part of the Land being the area marked “E-1” on the attached plan.

Published with the authority of Central Highlands Region Water Authority.

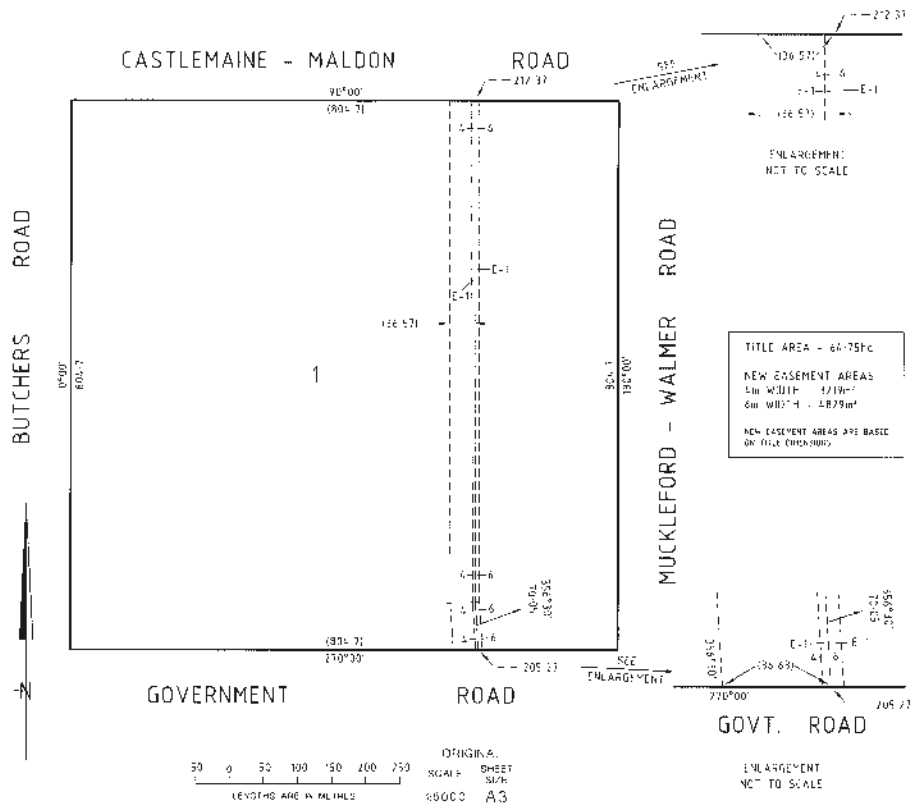

Dated 14 June 2007

Signed by  
**TONY WRIGHT**  
for and on behalf of  
Central Highland Region Water Authority  
CHW Project Director,  
Goldfields Superpipe

**SPECIAL**

**Land Acquisition and Compensation Act 1986**

**FORM 7**

**Notice of Acquisition**

**Compulsory Acquisition of Interest in Land**

Central Highlands Region Water Authority, ABN 75 224 340 348, of 7 Learmonth Road, Ballarat, Vic. 3353 declares that by this notice it acquires the following interest in the land described in Certificates of Title Volume 06461, Folio 013 and Volume 04419, Folio 793 ("Land"):

An Easement for the purposes of a pipeline for water over part of the Land being the area marked "E-1" on the attached plans.

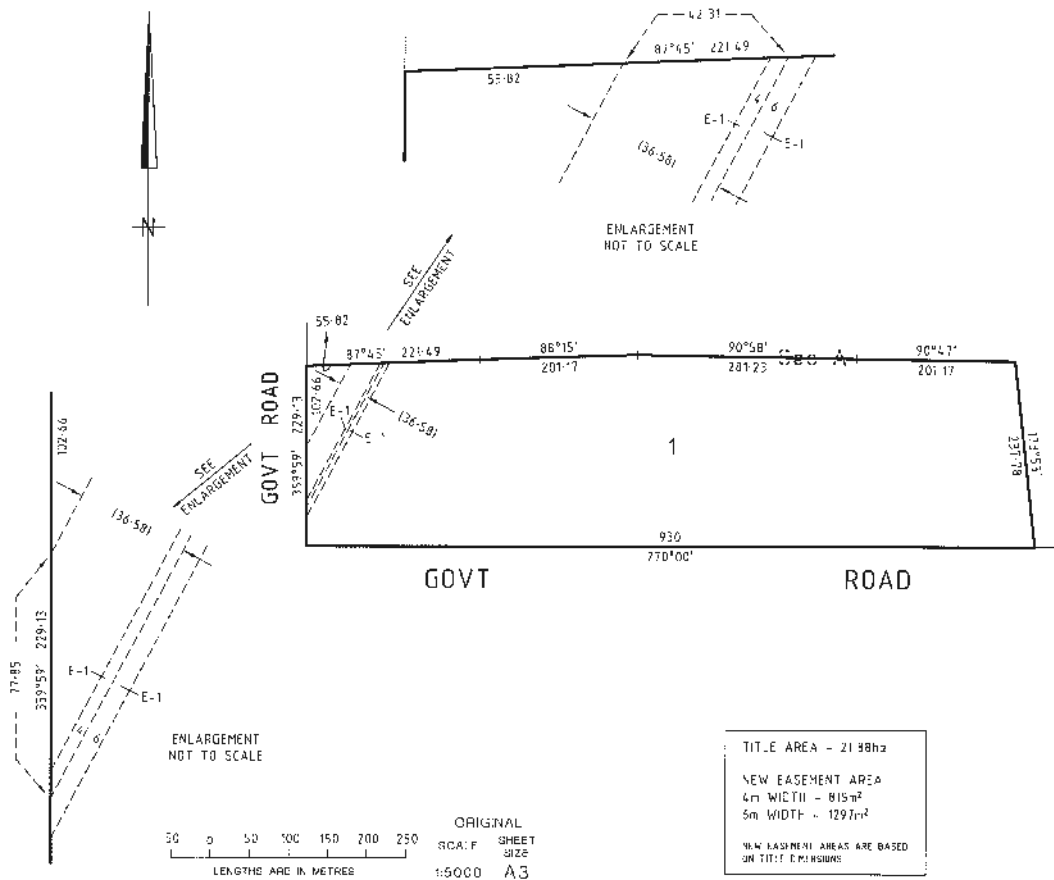

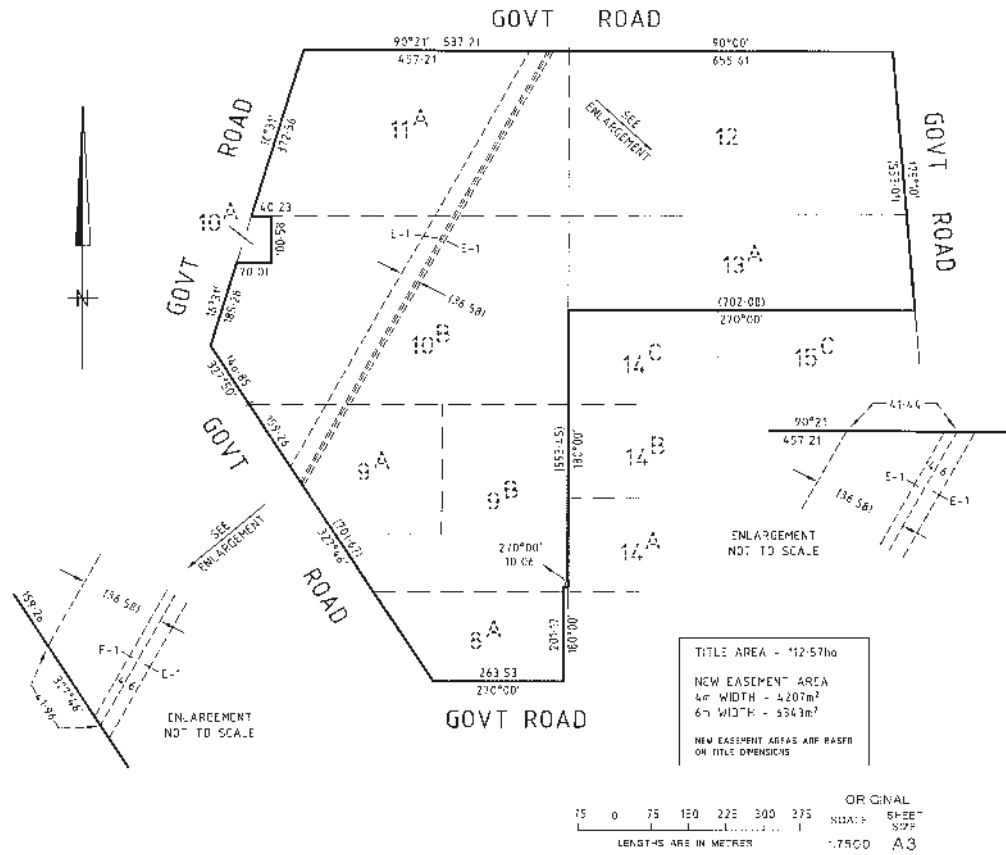

Published with the authority of Central Highlands Region Water Authority.  
Dated 14 June 2007

Signed by  
TONY WRIGHT  
for and on behalf of  
Central Highland Region Water Authority  
CHW Project Director,  
Goldfields Superpipe

**Land Acquisition and Compensation Act 1986**

**FORM 7**

**Notice of Acquisition**

**Compulsory Acquisition of Interest in Land**

Central Highlands Region Water Authority, ABN 75 224 340 348, of 7 Learmonth Road, Ballarat, Vic. 3353 declares that by this notice it acquires the following interest in the land described in Certificate of Title Volume 09835, Folio 366 ("Land"):

An Easement for the purposes of a pipeline for water over part of the Land being the area marked "E-1" on the attached plan.

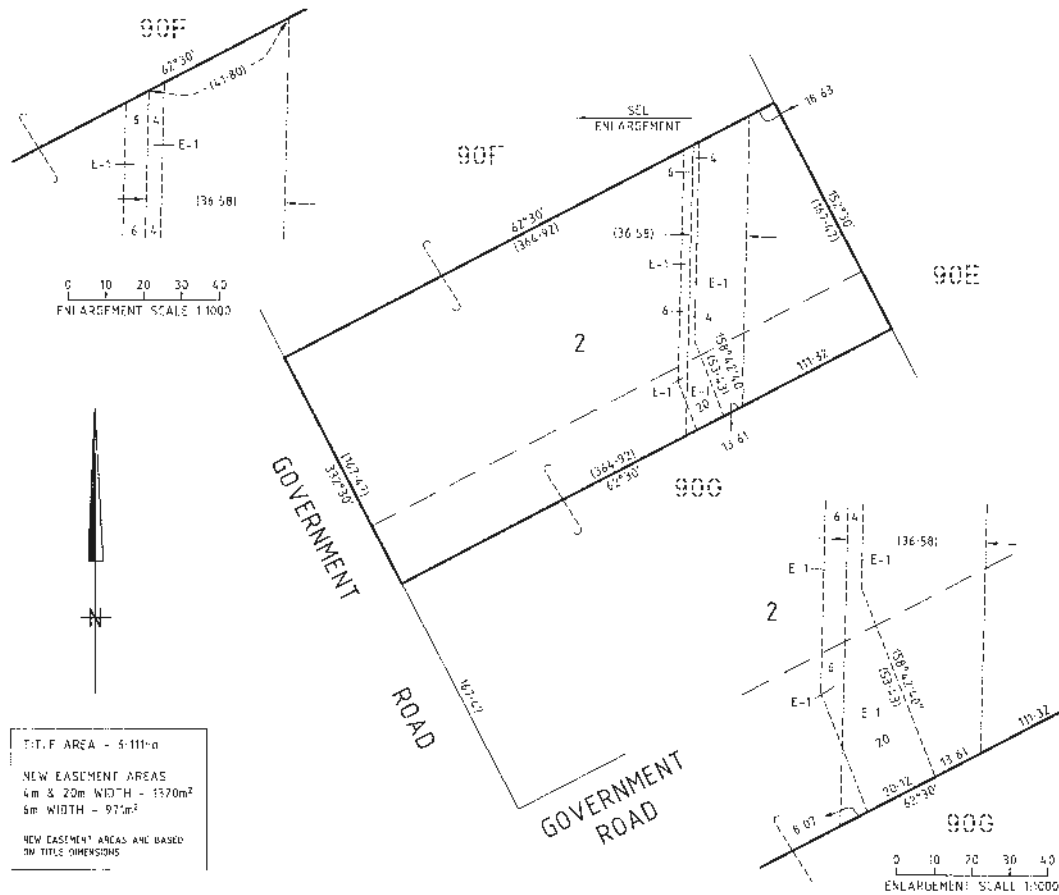

Published with the authority of Central Highlands Region Water Authority  
 Dated 14 June 2007

Signed by  
**TONY WRIGHT**  
 for and on behalf of  
 Central Highland Region Water Authority  
 CHW Project Director,  
 Goldfields Superpipe

**Land Acquisition and Compensation Act 1986**

**FORM 7**

**Notice of Acquisition**

**Compulsory Acquisition of Interest in Land**

Central Highlands Region Water Authority, ABN 75 224 340 348, of 7 Learmonth Road, Ballarat, Vic. 3353 declares that by this notice it acquires the following interest in the land described in Certificate of Title Volume 10114, Folio 421 ("Land"):

An Easement for the purposes of a pipeline for water over part of the Land being the area marked "E-1" on the attached plan.

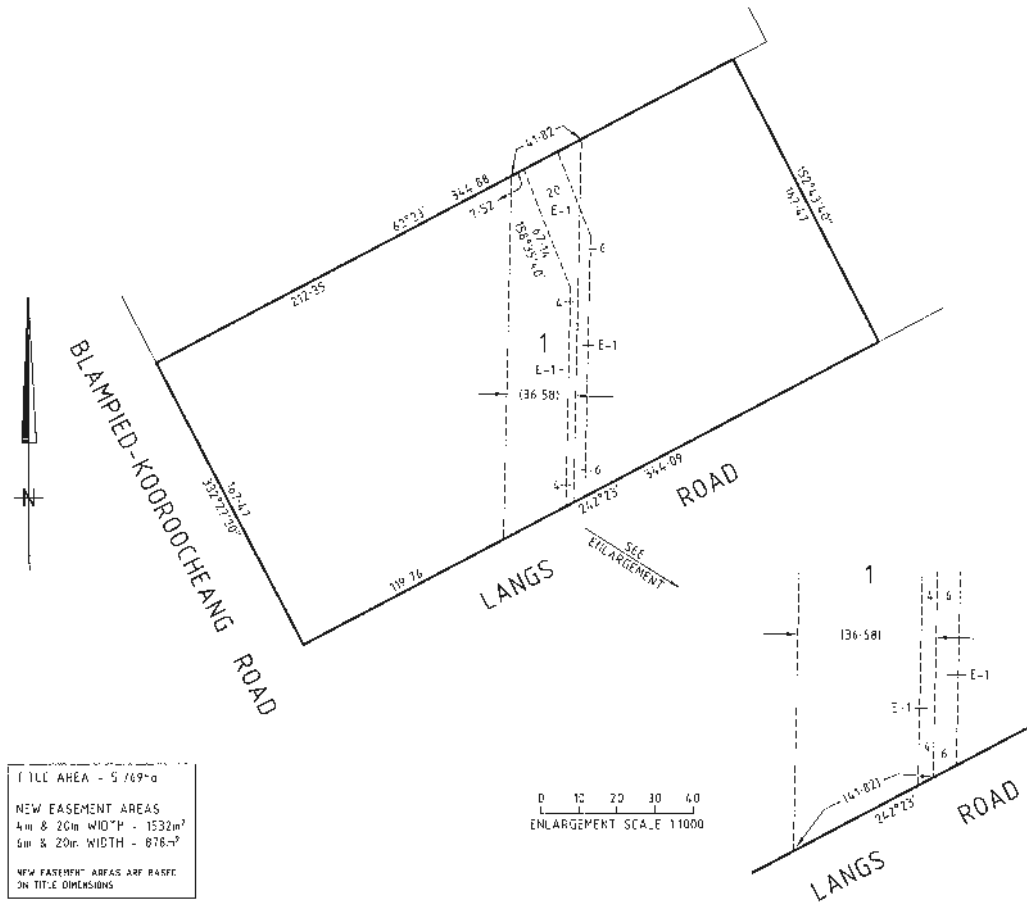

Published with the authority of Central Highlands Region Water Authority.  
Dated 14 June 2007

Signed by  
TONY WRIGHT  
for and on behalf of  
Central Highland Region Water Authority  
CHW Project Director,  
Goldfields Superpipe

**Land Acquisition and Compensation Act 1986**

**FORM 7**

**Notice of Acquisition**

**Compulsory Acquisition of Interest in Land**

Central Highlands Region Water Authority ABN 75 224 340 348 of 7 Learmonth Road Ballarat Vic 3353 declares that by this notice it acquires the following interest in the land described in Certificate of Title Volume 10574, Folio 749 ("Land"):

An Easement for the purposes of a pipeline for water over part of the Land being the area marked "E-1" on the attached plan.

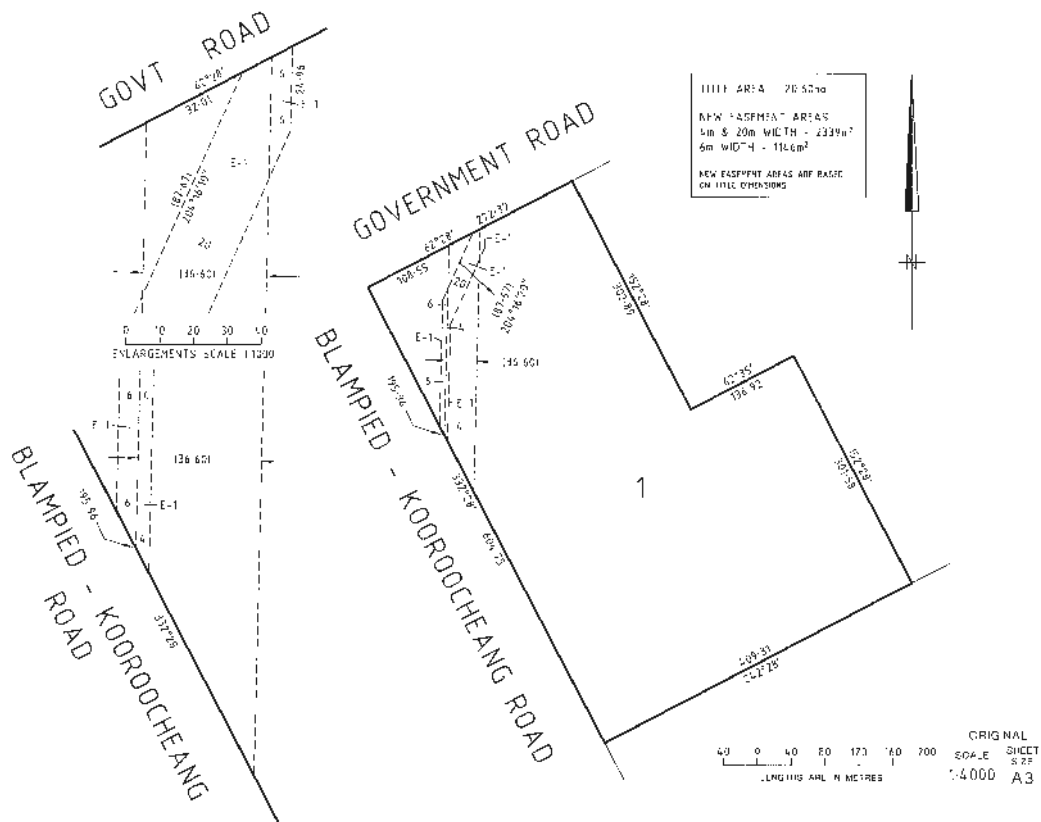

Published with the authority of Central Highlands Region Water Authority.  
Dated 14 June 2007

Signed by  
**TONY WRIGHT**  
for and on behalf of  
Central Highland Region Water Authority  
CHW Project Director,  
Goldfields Superpipe

**Land Acquisition and Compensation Act 1986**

**FORM 7**

**Notice of Acquisition**

**Compulsory Acquisition of Interest in Land**

Central Highlands Region Water Authority, ABN 75 224 340 348, of 7 Learmonth Road, Ballarat, Vic. 3353 declares that by this notice it acquires the following interest in the land described in Certificate of Title Volume 09661, Folio 287 ("Land"):

An Easement for the purposes of a pipeline for water over part of the Land being the area marked "E-1" on the attached plan.

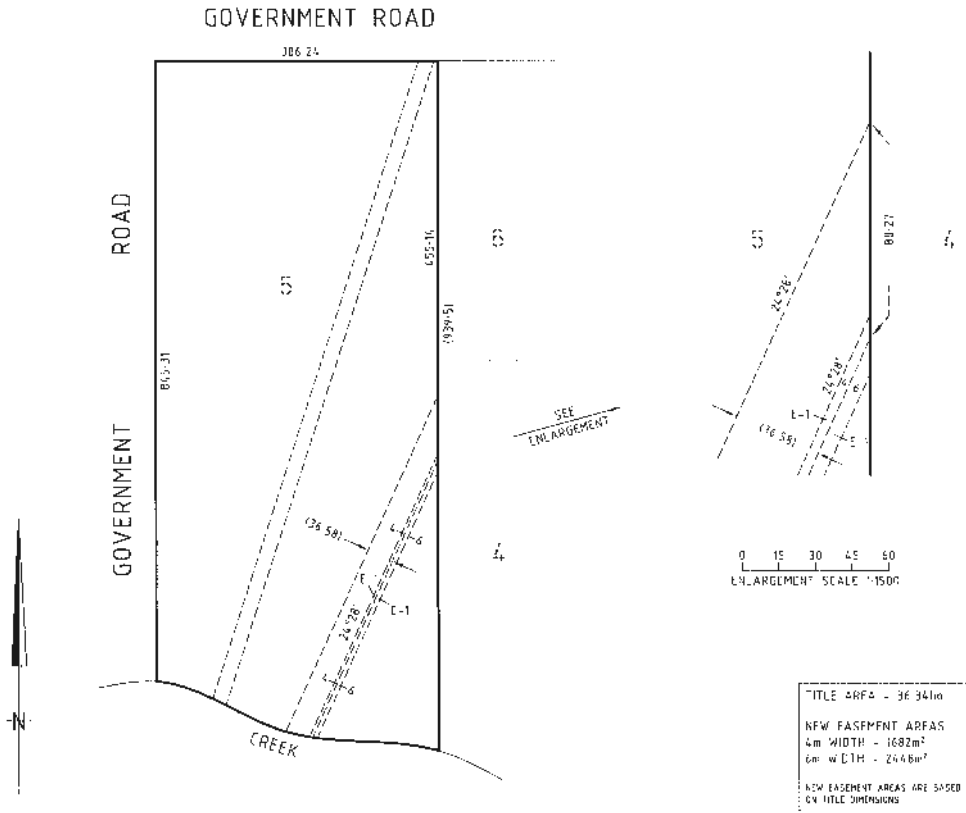

Published with the authority of Central Highlands Region Water Authority.  
Dated 14 June 2007

Signed by  
**TONY WRIGHT**  
for and on behalf of  
Central Highland Region Water Authority  
CHW Project Director,  
Goldfields Superpipe

**Land Acquisition and Compensation Act 1986**

**FORM 7**

**Notice of Acquisition**

**Compulsory Acquisition of Interest in Land**

Central Highlands Region Water Authority, ABN 75 224 340 348, of 7 Learmonth Road, Ballarat, Vic. 3353 declares that by this notice it acquires the following interest in the land described in Certificate of Title Volume 09997, Folio 653 ("Land"):

An Easement for the purposes of a pipeline for water over part of the Land being the area marked "E-1" on the attached plan.

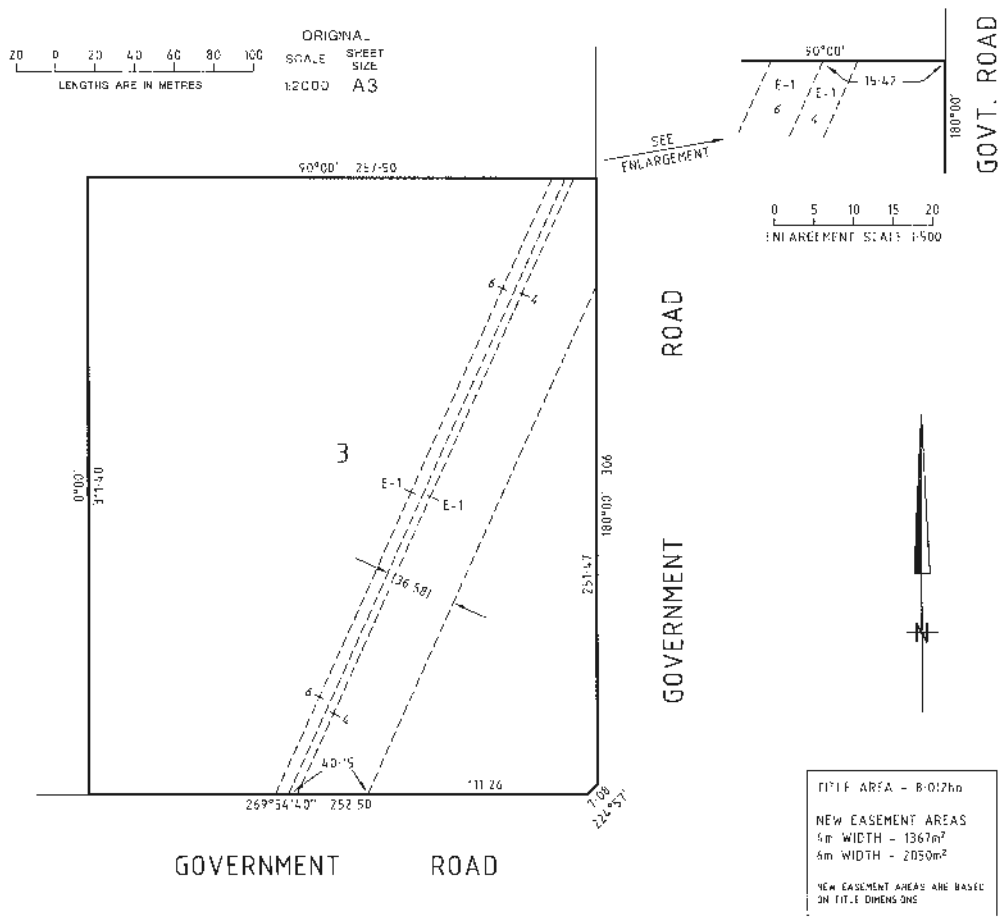

Published with the authority of Central Highlands Region Water Authority.  
 Dated 14 June 2007

Signed by  
**TONY WRIGHT**  
 for and on behalf of  
 Central Highland Region Water Authority  
 CHW Project Director,  
 Goldfields Superpipe



**Land Acquisition and Compensation Act 1986**

**FORM 7**

**Notice of Acquisition**

**Compulsory Acquisition of Interest in Land**

Central Highlands Region Water Authority, ABN 75 224 340 348, of 7 Learmonth Road, Ballarat, Vic. 3353 declares that by this notice it acquires the following interest in the land described in Certificate of Title Volume 10132, Folio 604 ("Land"):

An Easement for the purposes of a pipeline for water over part of the Land being the area marked "E-1" on the attached plan.

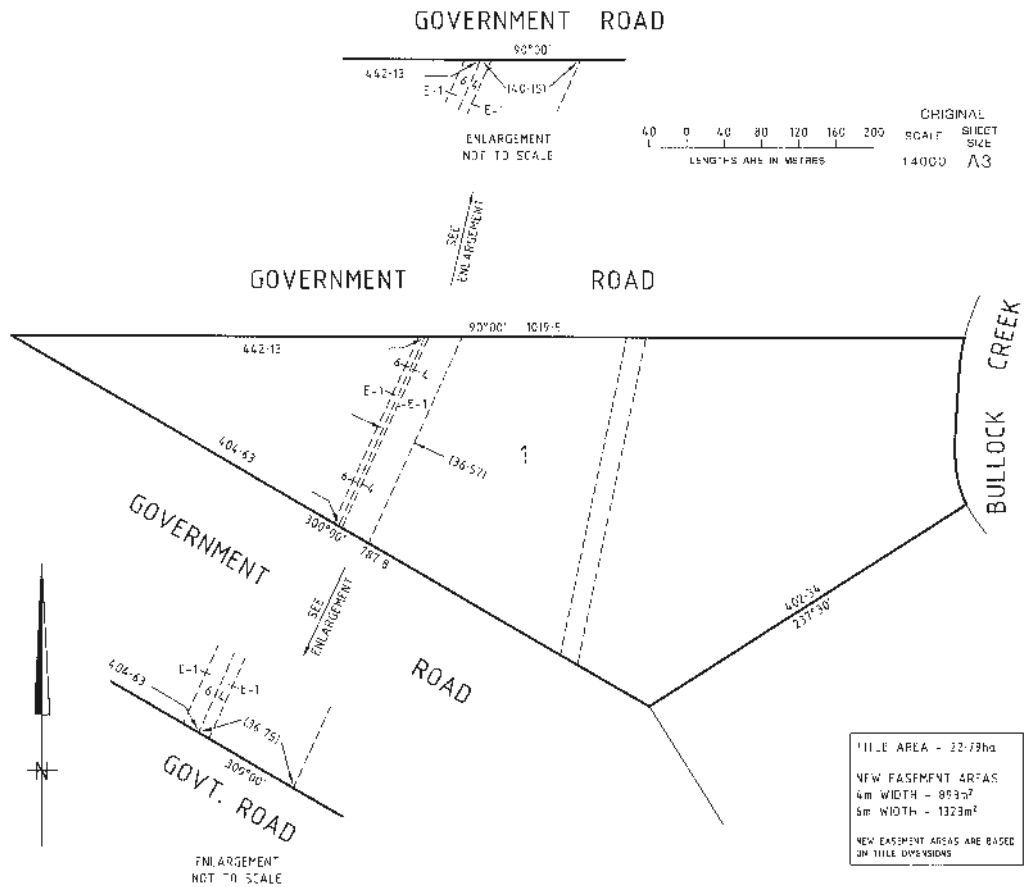

Published with the authority of Central Highlands Region Water Authority.  
Dated 14 June 2007

Signed by  
**TONY WRIGHT**  
for and on behalf of  
Central Highland Region Water Authority  
CHW Project Director,  
Goldfields Superpipe

**Land Acquisition and Compensation Act 1986**

**FORM 7**

**Notice of Acquisition**

**Compulsory Acquisition of Interest in Land**

Central Highlands Region Water Authority, ABN 75 224 340 348, of 7 Learmonth Road, Ballarat, Vic. 3353 declares that by this notice it acquires the following interest in the land described in Certificate of Title Volume 10719, Folio 015 ("Land"):

An Easement for the purposes of a pipeline for water over part of the Land being the area marked "E-1" on the attached plan.

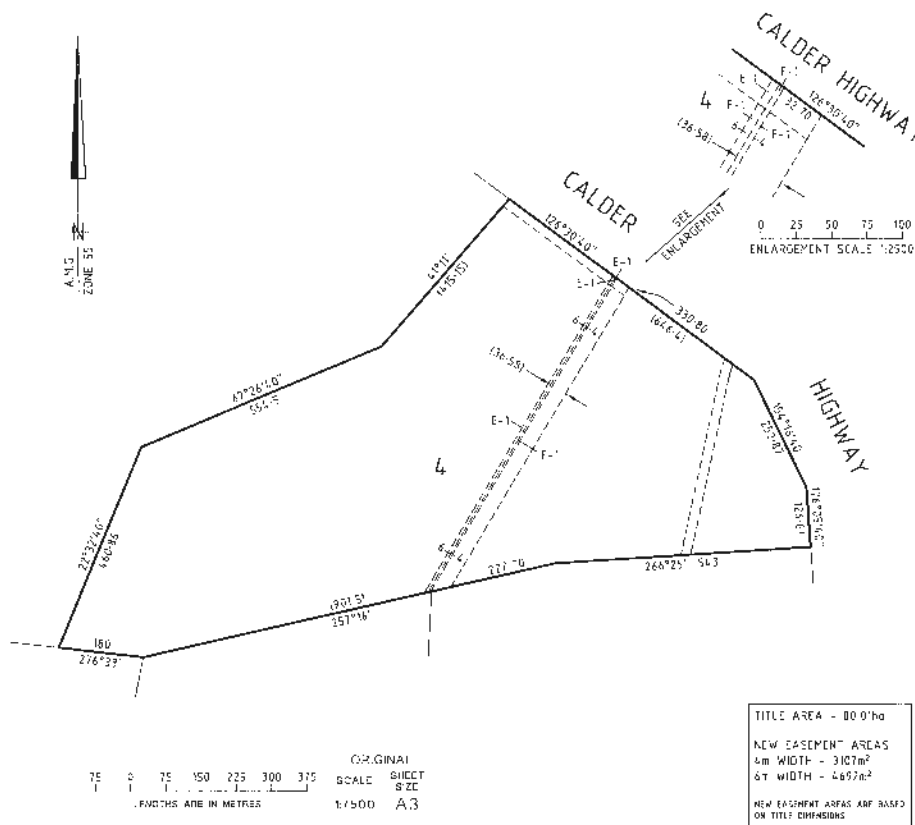

Published with the authority of Central Highlands Region Water Authority.  
Dated 14 June 2007

Signed by  
**TONY WRIGHT**  
for and on behalf of  
Central Highland Region Water Authority  
CHW Project Director,  
Goldfields Superpipe

**Land Acquisition and Compensation Act 1986**

**FORM 7**

**Notice of Acquisition**

**Compulsory Acquisition of Interest in Land**

Central Highlands Region Water Authority, ABN 75 224 340 348, of 7 Learmonth Road, Ballarat, Vic. 3353 declares that by this notice it acquires the following interest in the land described in Certificate of Title Volume 10719, Folio 016 ("Land"):

An Easement for the purposes of a pipeline for water over part of the Land being the area marked "E-1" on the attached plan.

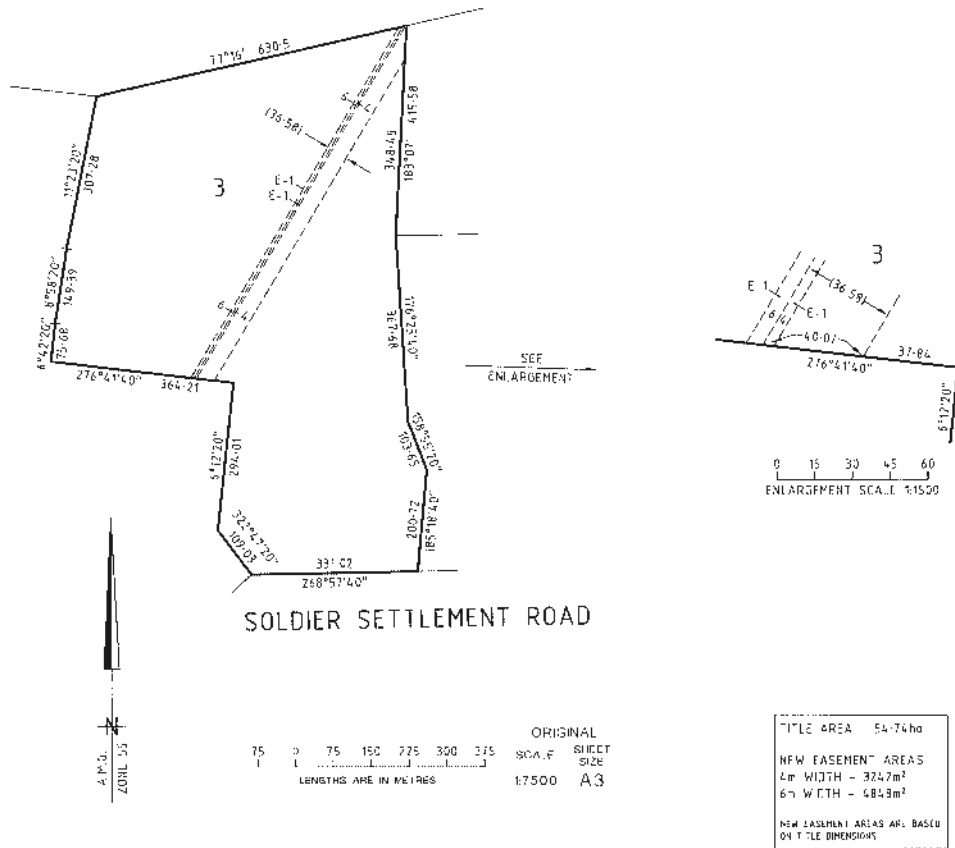

Published with the authority of Central Highlands Region Water Authority.

Dated 14 June 2007

Signed by  
**TONY WRIGHT**  
 for and on behalf of  
 Central Highland Region Water Authority  
 CHW Project Director,  
 Goldfields Superpipe

**Land Acquisition and Compensation Act 1986**

**FORM 7**

**Notice of Acquisition**

**Compulsory Acquisition of Interest in Land**

Central Highlands Region Water Authority, ABN 75 224 340 348, of 7 Learmonth Road, Ballarat, Vic. 3353 declares that by this notice it acquires the following interest in the land described in Crown Lease Volume 01205, Folio 191 ("Land"):

An Easement for the purposes of a pipeline for water over part of the Land being the area marked "E-1" on the attached plan.

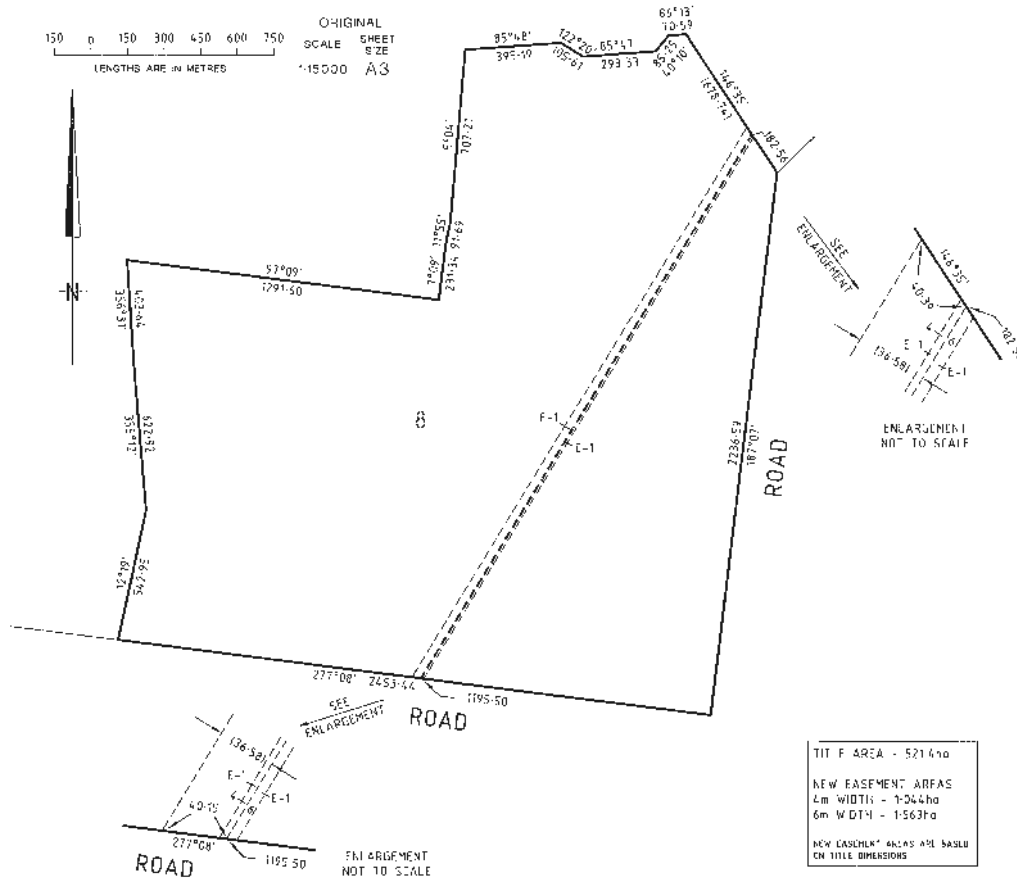

Published with the authority of Central Highlands Region Water Authority.  
Dated 14 June 2007

Signed by  
**TONY WRIGHT**  
for and on behalf of  
Central Highland Region Water Authority  
CHW Project Director,  
Goldfields Superpipe

**Land Acquisition and Compensation Act 1986**

**FORM 7**

**Notice of Acquisition**

**Compulsory Acquisition of Interest in Land**

Central Highlands Region Water Authority, ABN 75 224 340 348, of 7 Learmonth Road, Ballarat, Vic. 3353 declares that by this notice it acquires the following interest in the land described in Certificates of Title Volume 03955, Folio 859, Volume 08560, Folio 873 and Volume 00517, Folio 305 ("Land"):

An Easement for the purposes of a pipeline for water over part of the Land being the area marked "E-1" on the attached plans.

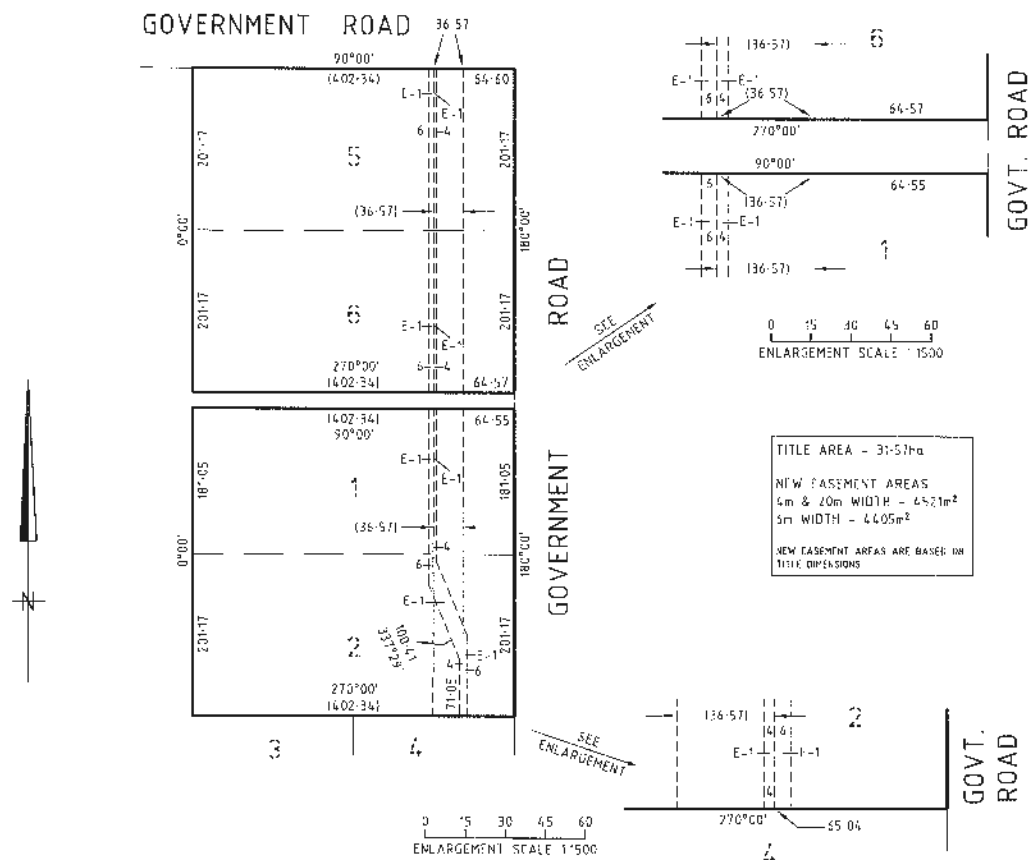

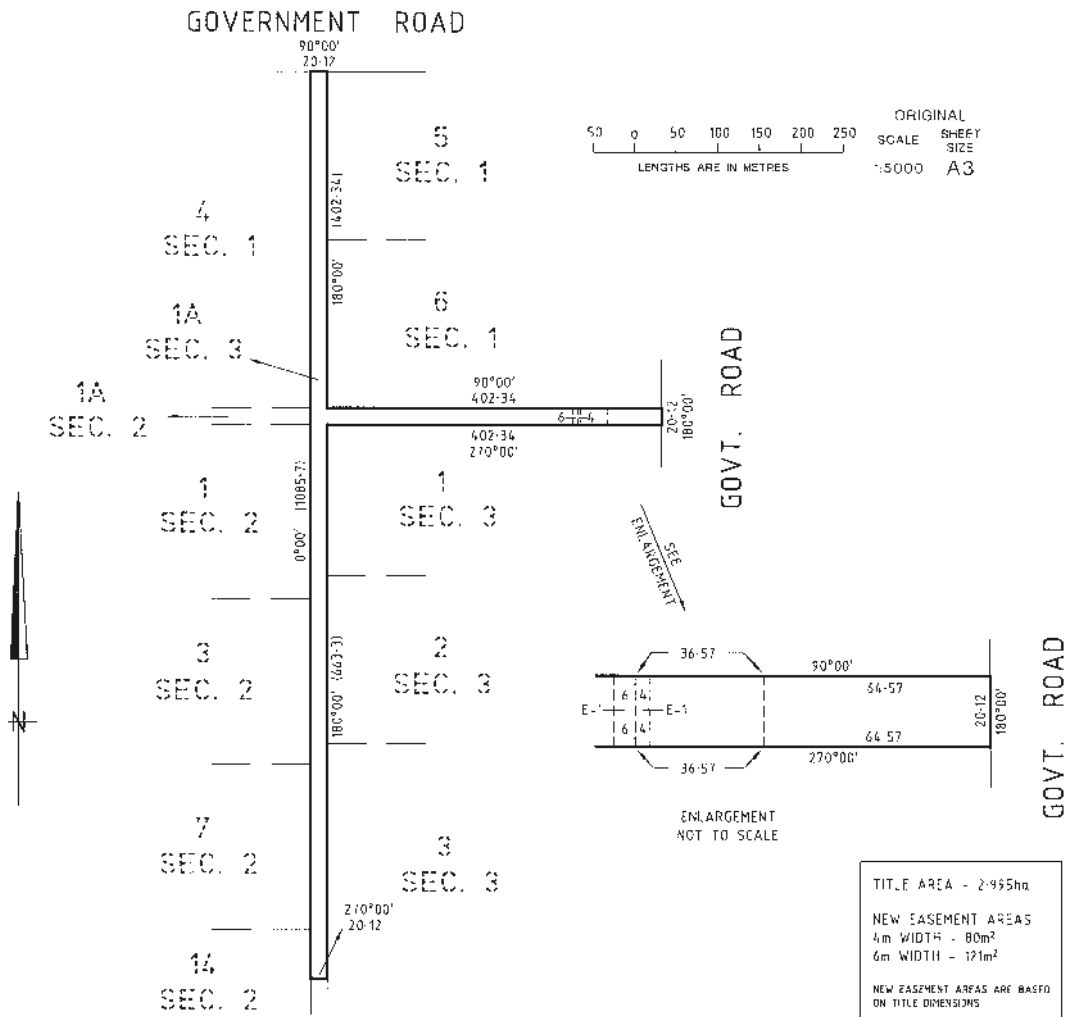

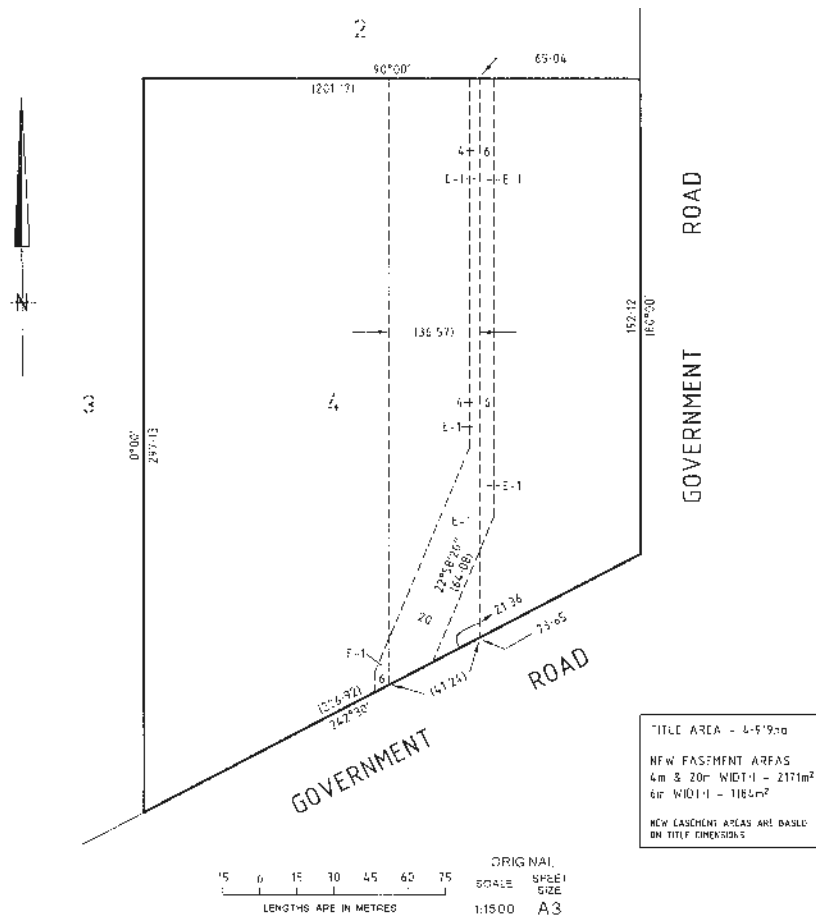

Published with the authority of Central Highlands Region Water Authority.  
 Dated 14 June 2007

Signed by  
 TONY WRIGHT  
 for and on behalf of  
 Central Highland Region Water Authority  
 CHW Project Director,  
 Goldfields Superpipe

**Land Acquisition and Compensation Act 1986**

**FORM 7**

**Notice of Acquisition**

**Compulsory Acquisition of Interest in Land**

Central Highlands Region Water Authority, ABN 75 224 340 348, of 7 Learmonth Road, Ballarat, Vic. 3353 declares that by this notice it acquires the following interest in the land described in Certificate of Title Volume 10483, Folio 445 ("Land"):

An Easement for the purposes of a pipeline for water over part of the Land being the area marked "E-1" on the attached plan.

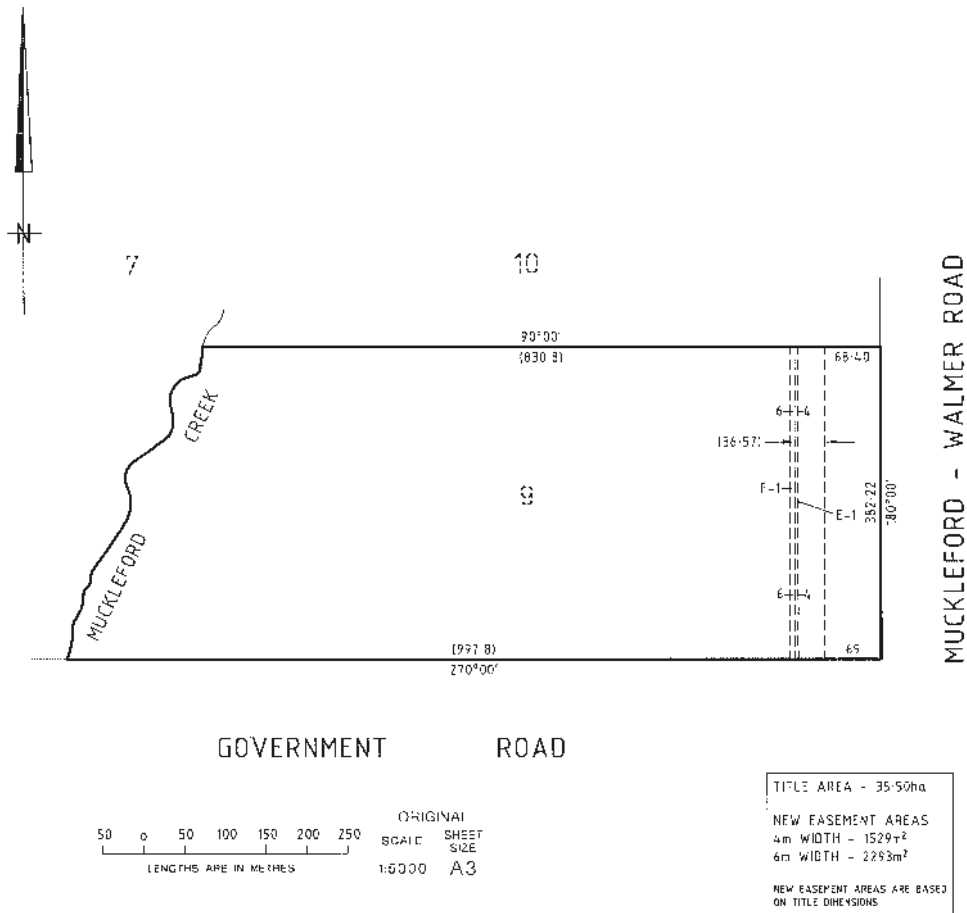

Published with the authority of Central Highlands Region Water Authority.  
 Dated 14 June 2007

Signed by  
 TONY WRIGHT  
 for and on behalf of  
 Central Highland Region Water Authority  
 CHW Project Director,  
 Goldfields Superpipe



**Land Acquisition and Compensation Act 1986**

**FORM 7**

**Notice of Acquisition**

**Compulsory Acquisition of Interest in Land**

Central Highlands Region Water Authority, ABN 75 224 340 348, of 7 Learmonth Road, Ballarat, Vic. 3353 declares that by this notice it acquires the following interest in the land described in Certificates of Title Volume 07640, Folio 116, Volume 07640, Folio 117, Volume 09595, Folio 801, Volume 09595, Folio 798 and Volume 09595, Folio 799 ("Land"):

An Easement for the purposes of a pipeline for water over part of the Land being the area marked "E-1" on the attached plans.

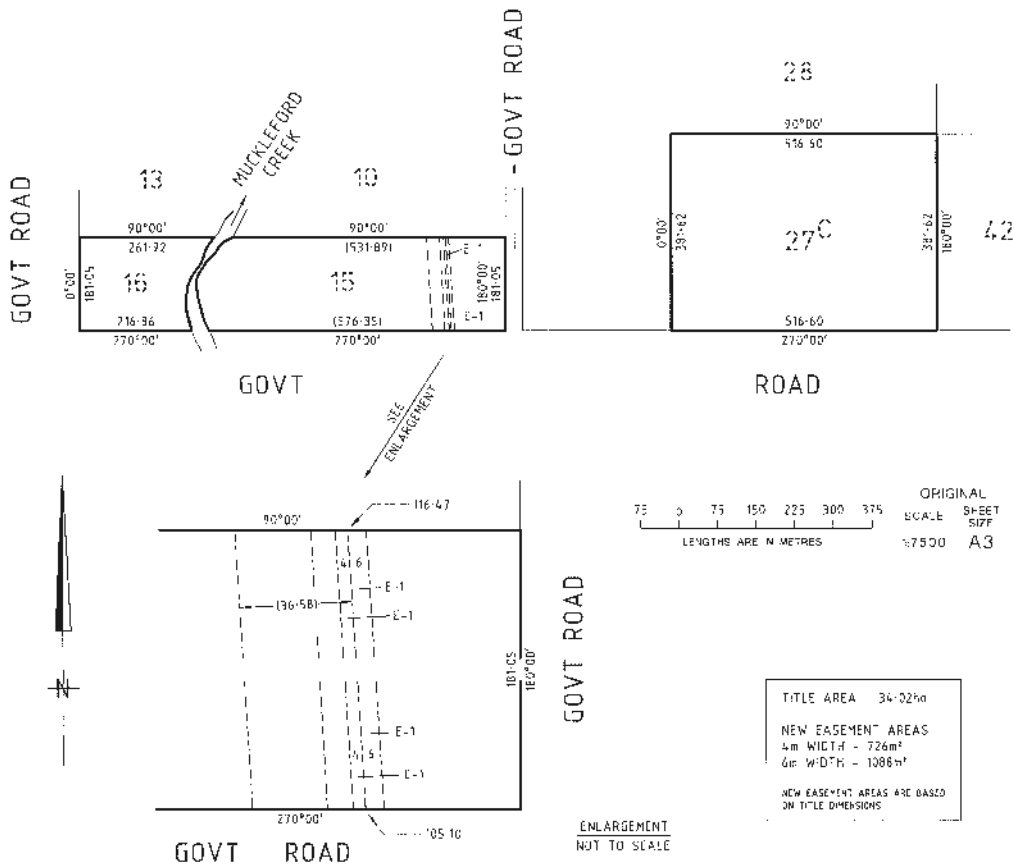

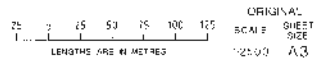
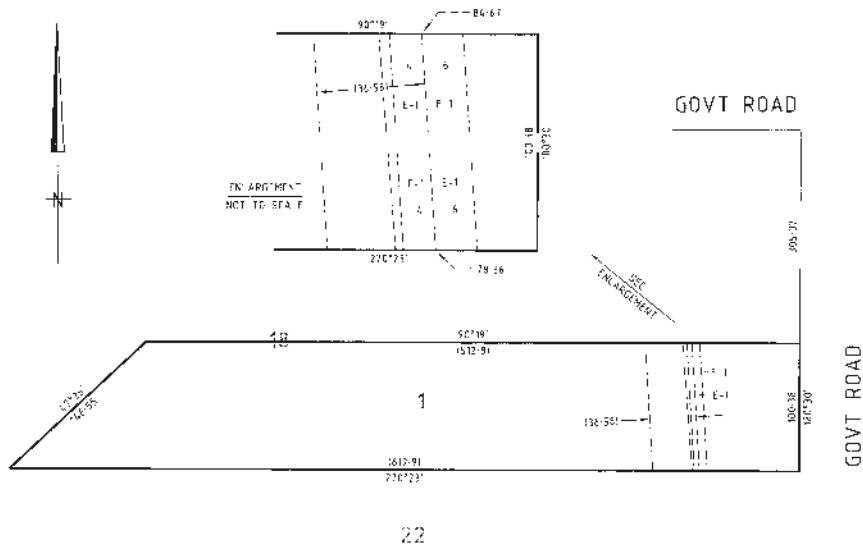

TITLE AREA - 558670  
NEW EASEMENT AREA  
NW WIDTH - 602m  
SW WIDTH - 603m  
NEW EASEMENT AREAS ARE BASED ON TITLE DIMENSIONS

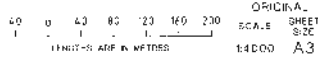
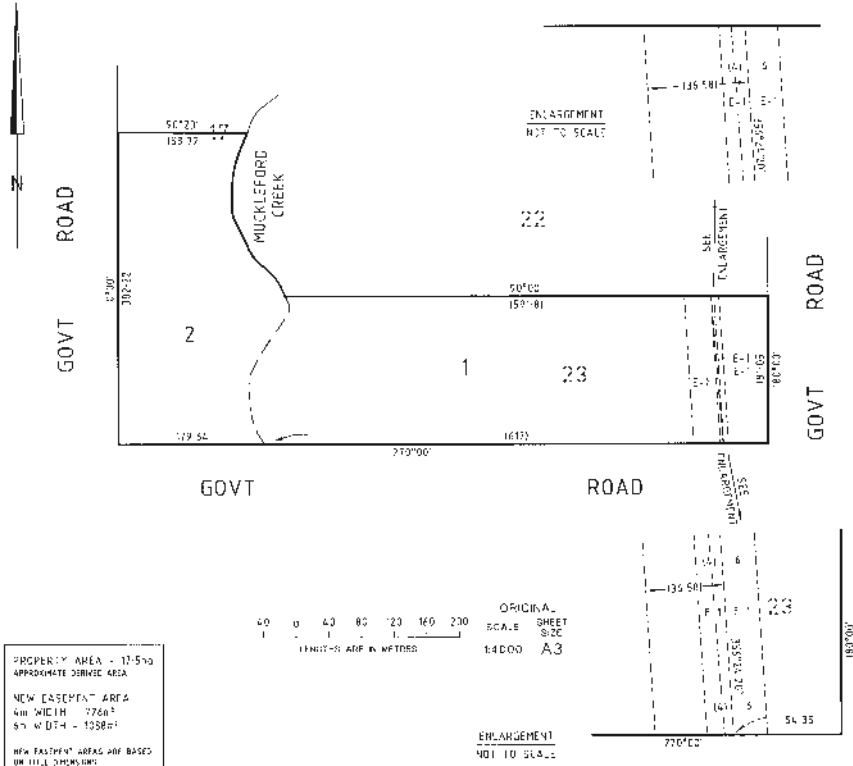

PROPERTY AREA - 11570  
APPROXIMATE SURVEY AREA  
NEW EASEMENT AREA  
NW WIDTH - 776m  
SW WIDTH - 1038m  
NEW EASEMENT AREAS ARE BASED ON TITLE DIMENSIONS

ENLARGEMENT  
NOT TO SCALE

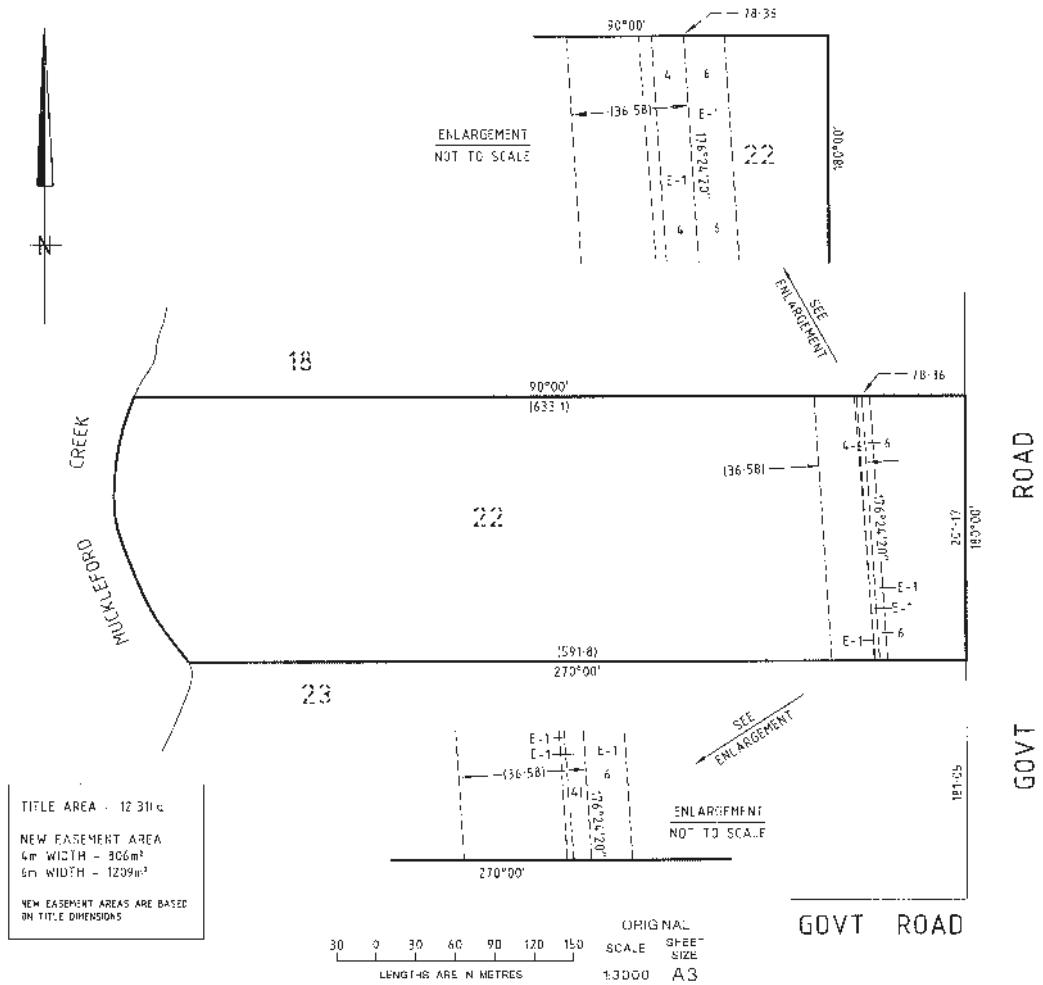

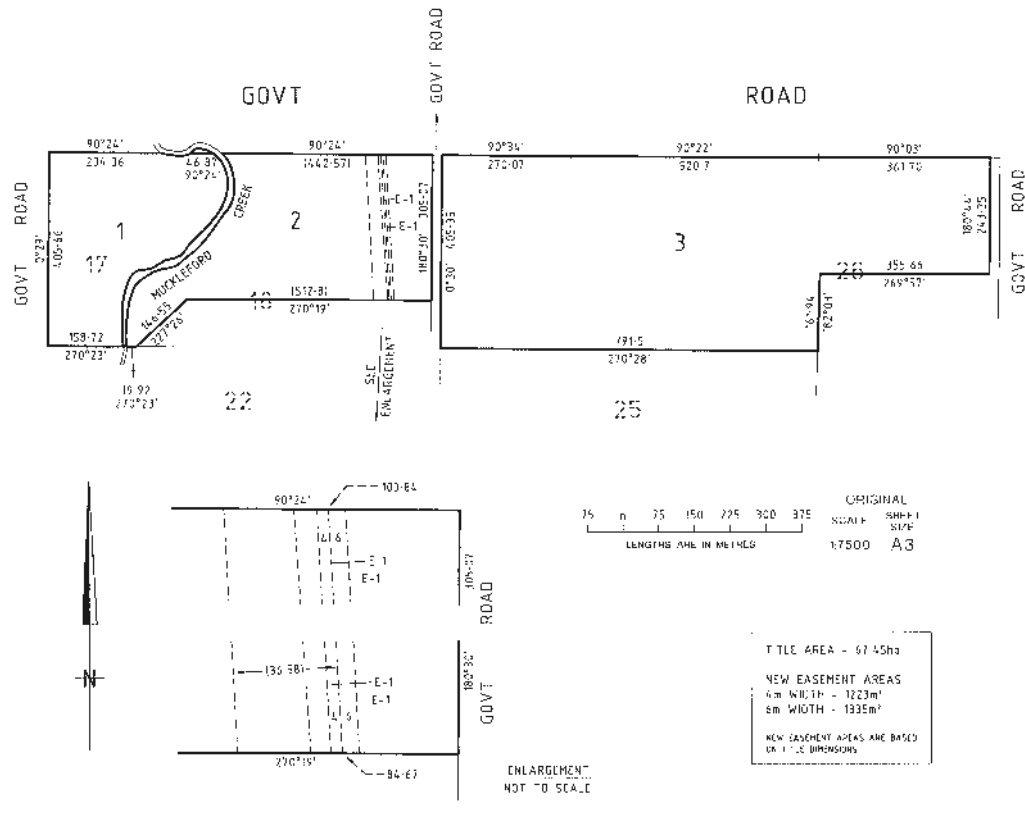

Published with the authority of Central Highlands Region Water Authority.  
 Dated 14 June 2007

Signed by  
**TONY WRIGHT**  
 for and on behalf of  
 Central Highland Region Water Authority  
 CHW Project Director,  
 Goldfields Superpipe

**Land Acquisition and Compensation Act 1986**

**FORM 7**

**Notice of Acquisition**

**Compulsory Acquisition of Interest in Land**

Central Highlands Region Water Authority, ABN 75 224 340 348, of 7 Learmonth Road, Ballarat, Vic. 3353 declares that by this notice it acquires the following interest in the land described in Certificates of Title Volume 09595, Folio 797, Volume 10369, Folio 978 and Volume 10443, Folio 740 ("Land"):

An Easement for the purposes of a pipeline for water over part of the Land being the area marked "E-1" on the attached plans.

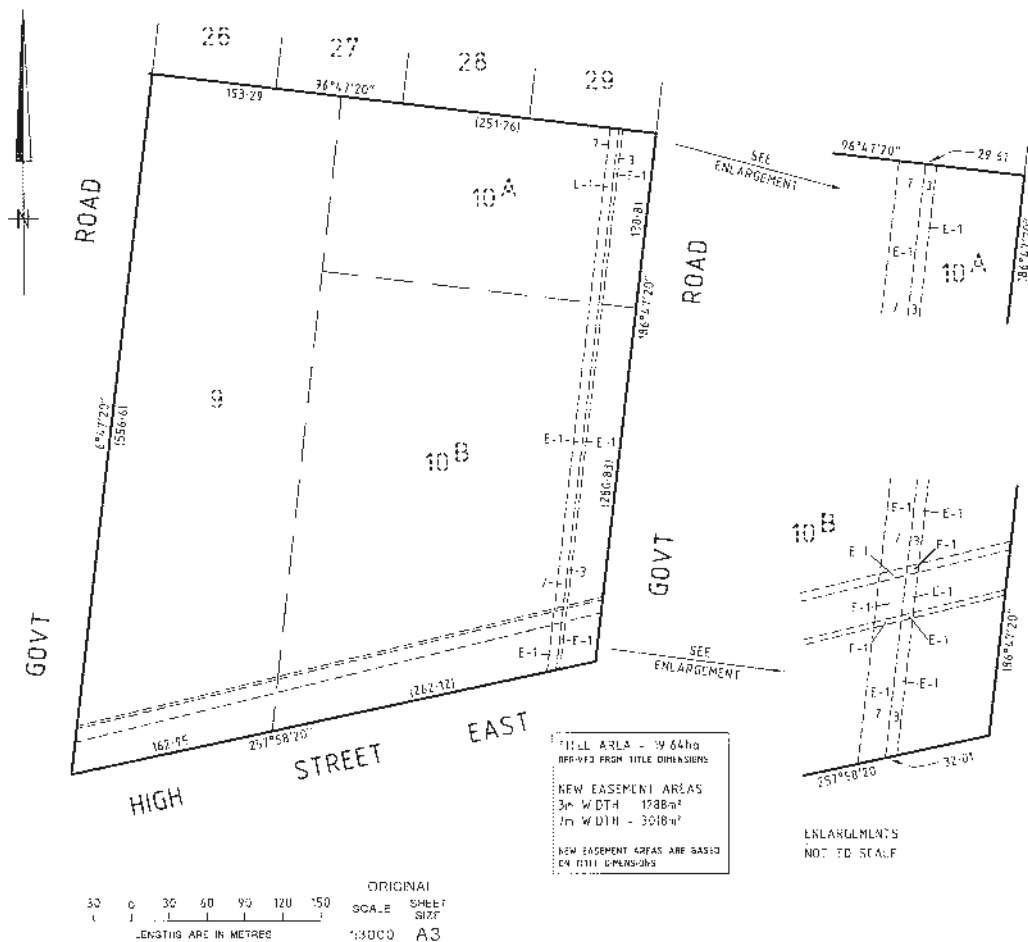

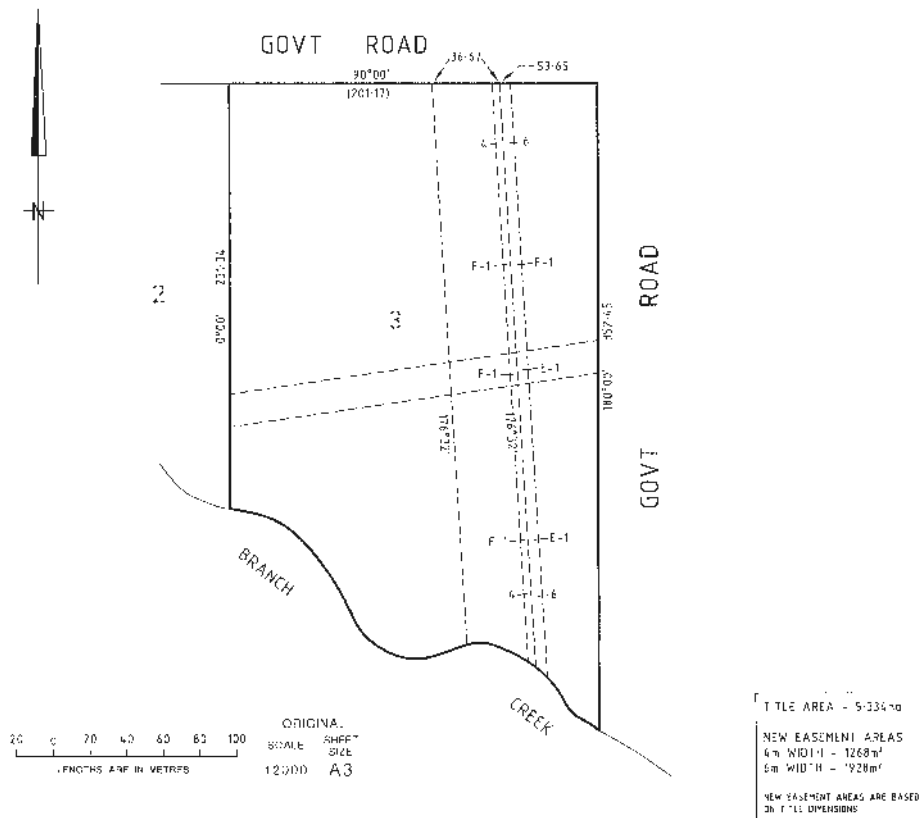

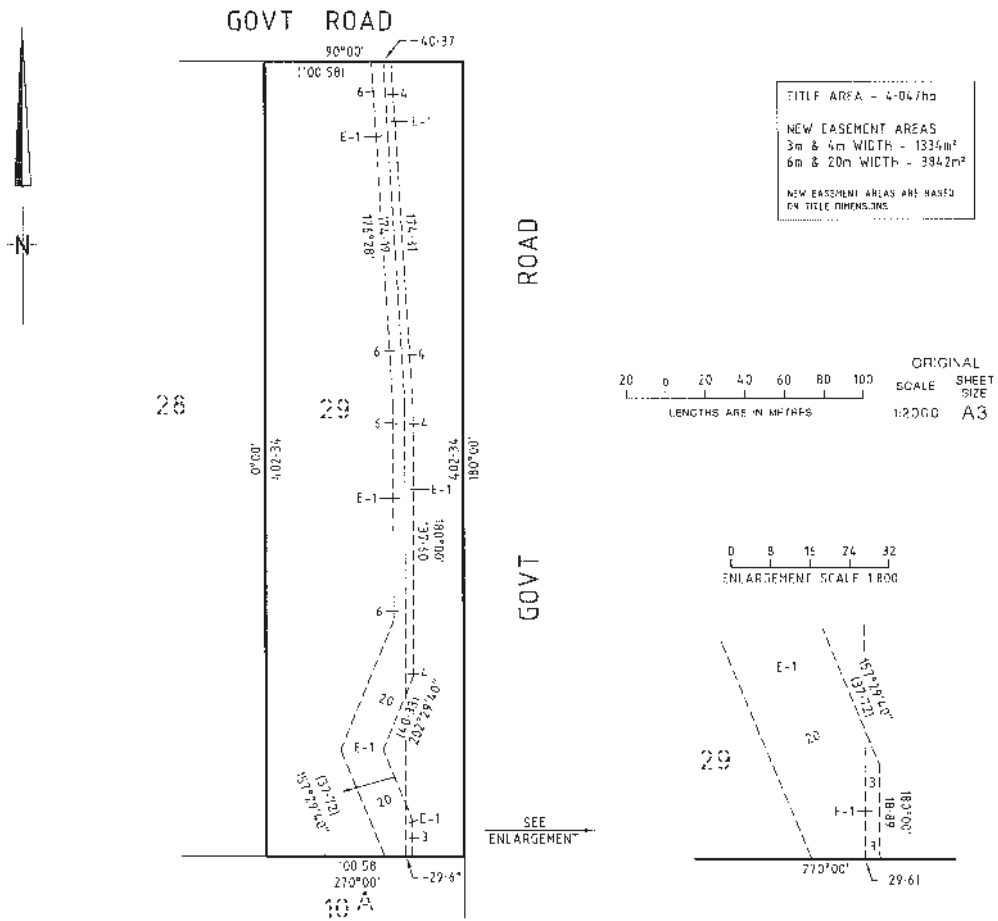

Published with the authority of Central Highlands Region Water Authority.  
 Dated 14 June 2007

Signed by  
**TONY WRIGHT**  
 for and on behalf of  
 Central Highland Region Water Authority  
 CHW Project Director,  
 Goldfields Superpipe

**Land Acquisition and Compensation Act 1986**

**FORM 7**

**Notice of Acquisition**

**Compulsory Acquisition of Interest in Land**

Central Highlands Region Water Authority, ABN 75 224 340 348, of 7 Learmonth Road, Ballarat, Vic. 3353 declares that by this notice it acquires the following interest in the land described in Memorial Book 657, Number 314 ("Land"):

An Easement for the purposes of a pipeline for water over part of the Land being the area marked "E-1" on the attached plan.

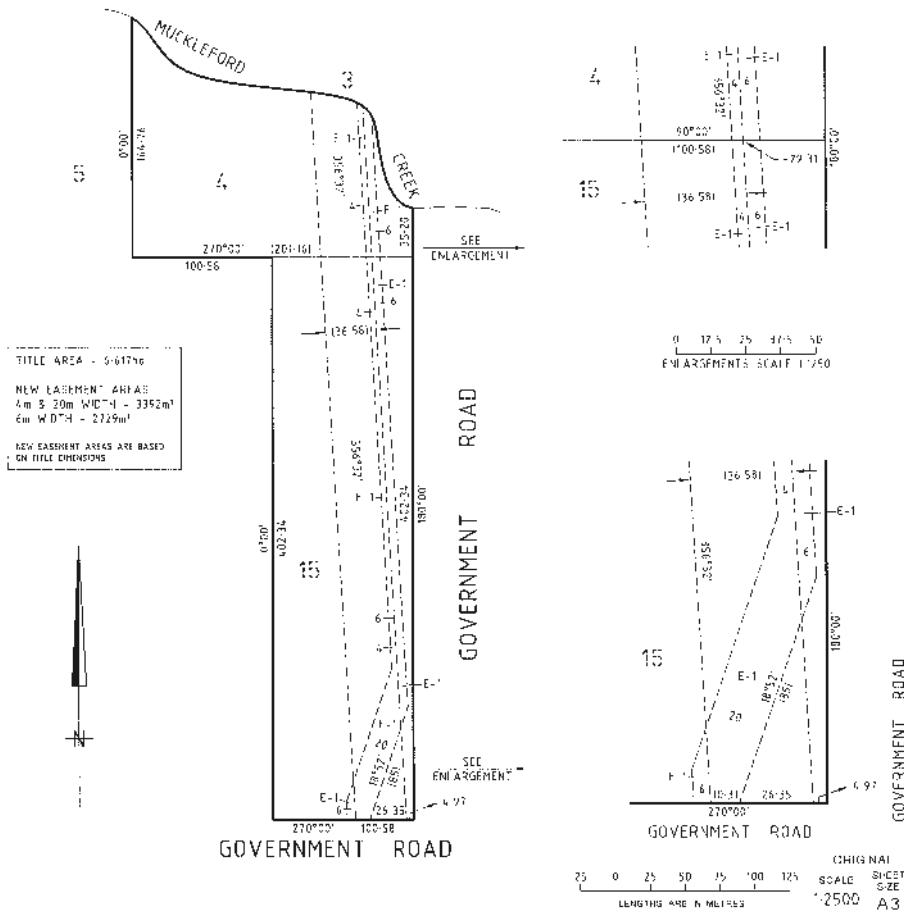

Published with the authority of Central Highlands Region Water Authority.  
 Dated 14 June 2007

Signed by  
**TONY WRIGHT**  
 for and on behalf of  
 Central Highland Region Water Authority  
 CHW Project Director,  
 Goldfields Superpipe



Land Acquisition and Compensation Act 1986

FORM 7

Notice of Acquisition

Compulsory Acquisition of Interest in Land

Central Highlands Region Water Authority, ABN 75 224 340 348, of 7 Learmonth Road, Ballarat, Vic. 3353 declares that by this notice it acquires the following interest in the land described in Certificate of Title Volume 08090, Folio 437 ("Land"):

An Easement for the purposes of a pipeline for water over part of the Land being the area marked "E-1" on the attached plan.

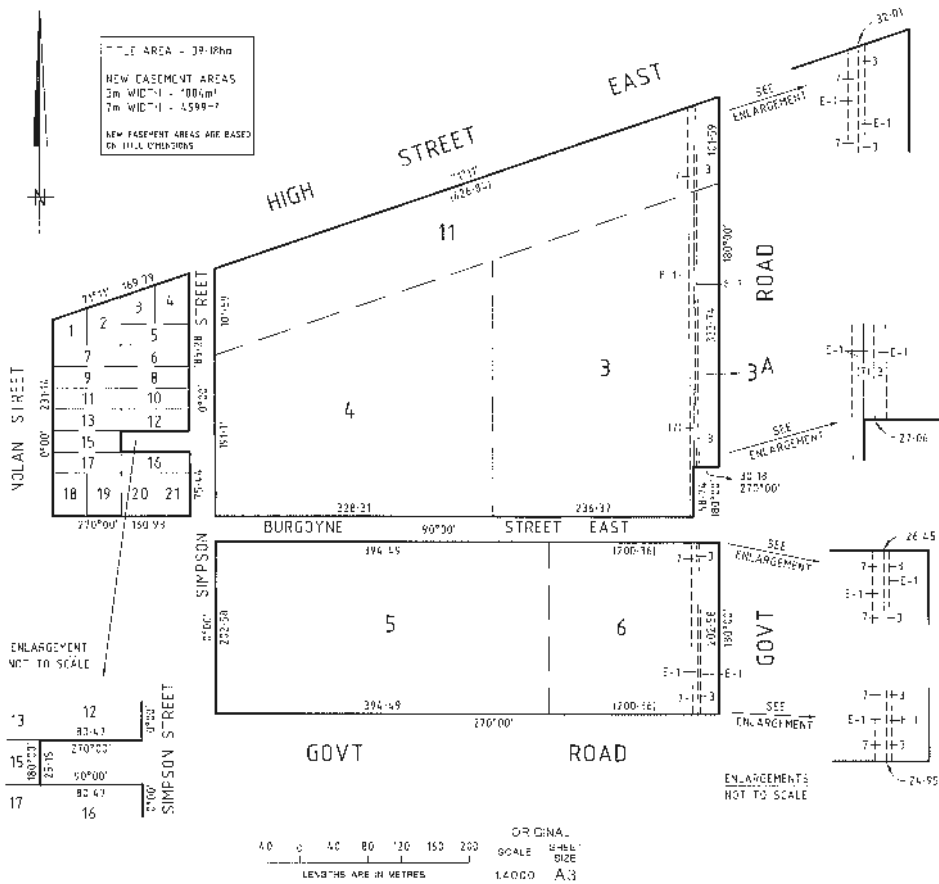

Published with the authority of Central Highlands Region Water Authority.  
Dated 14 June 2007

Signed by  
TONY WRIGHT  
for and on behalf of  
Central Highland Region Water Authority  
CHW Project Director,  
Goldfields Superpipe

**Land Acquisition and Compensation Act 1986**

**FORM 7**

**Notice of Acquisition**

**Compulsory Acquisition of Interest in Land**

Central Highlands Region Water Authority, ABN 75 224 340 348, of 7 Learmonth Road, Ballarat, Vic. 3353 declares that by this notice it acquires the following interest in the land described in Memorial Book 887, Number 482 ("Land"):

An Easement for the purposes of a pipeline for water over part of the Land being the area marked "E-1" on the attached plan.

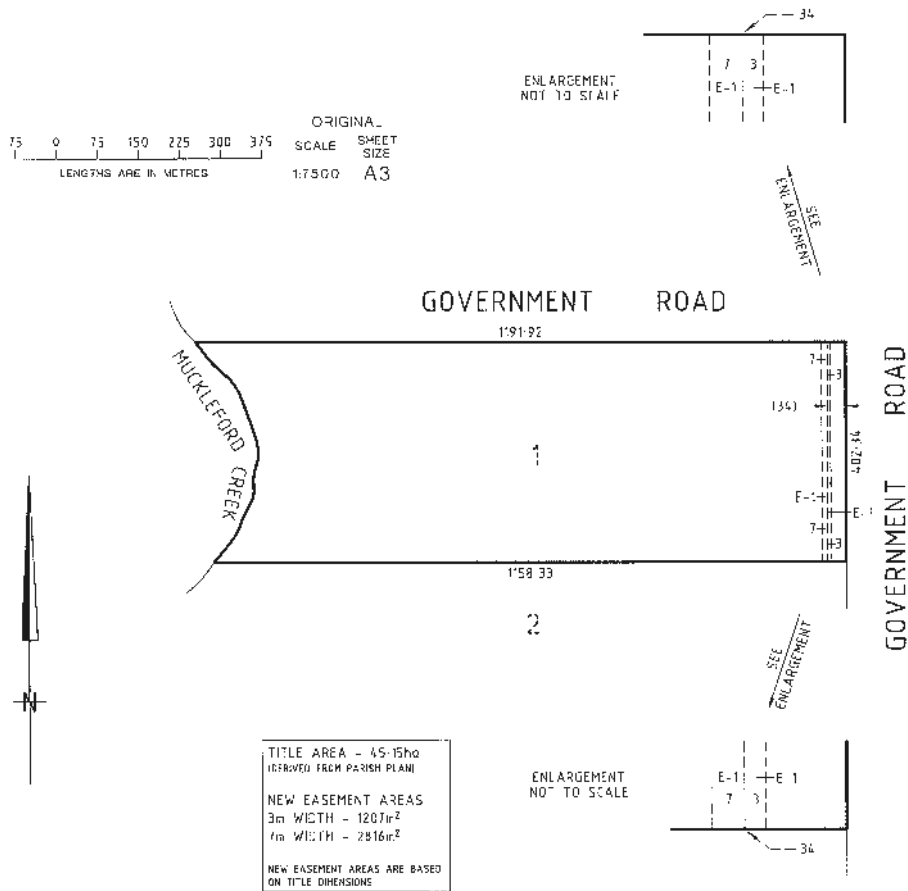

Published with the authority of Central Highlands Region Water Authority.  
Dated 14 June 2007

Signed by  
TONY WRIGHT  
for and on behalf of  
Central Highland Region Water Authority  
CHW Project Director,  
Goldfields Superpipe

**Land Acquisition and Compensation Act 1986**

**FORM 7**

Notice of Acquisition

Compulsory Acquisition of Interest in Land

Central Highlands Region Water Authority, ABN 75 224 340 348, of 7 Learmonth Road, Ballarat, Vic. 3353 declares that by this notice it acquires the following interest in the land described in Certificate of Title Volume 10439, Folio 690 ("Land"):

An Easement for the purposes of a pipeline for water over part of the Land being the area marked "E-1" on the attached plan.

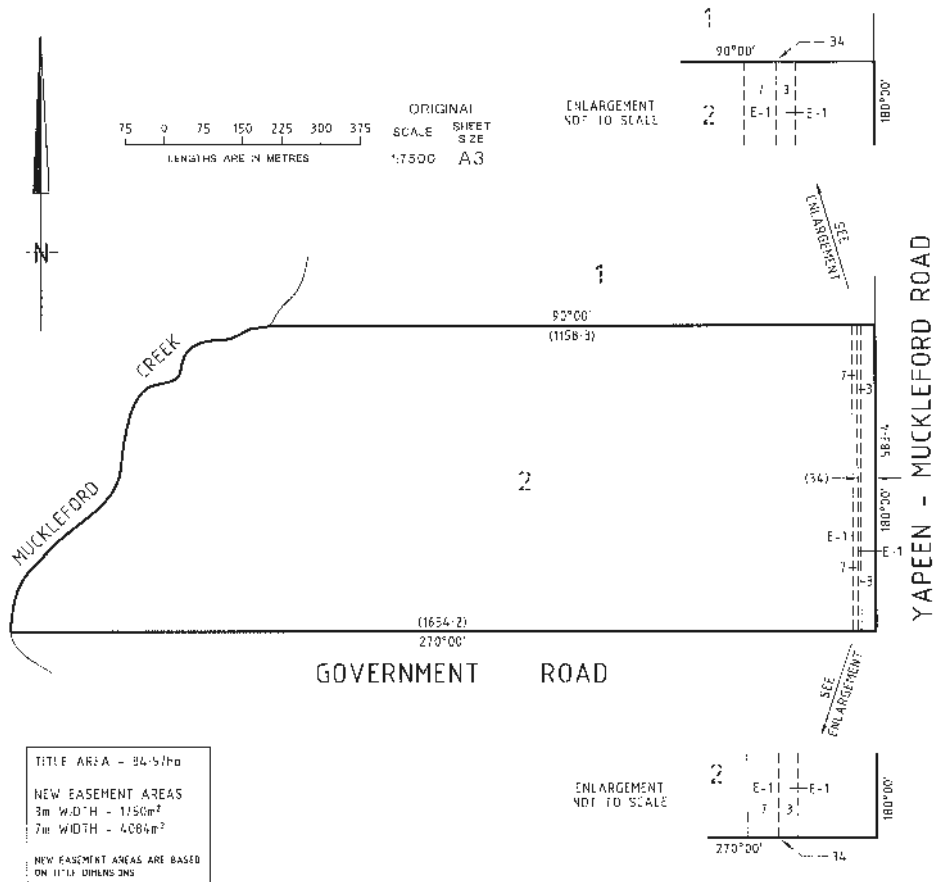

Published with the authority of Central Highlands Region Water Authority.  
Dated 14 June 2007

Signed by  
TONY WRIGHT  
for and on behalf of  
Central Highland Region Water Authority  
CHW Project Director,  
Goldfields Superpipe

**Land Acquisition and Compensation Act 1986**

**FORM 7**

**Notice of Acquisition**

**Compulsory Acquisition of Interest in Land**

Central Highlands Region Water Authority, ABN 75 224 340 348, of 7 Learmonth Road, Ballarat, Vic. 3353 declares that by this notice it acquires the following interest in the land described in Certificate of Title Volume 08675, Folio 455 ("Land"):

An Easement for the purposes of a pipeline for water over part of the Land being the area marked "E-1" on the attached plan.

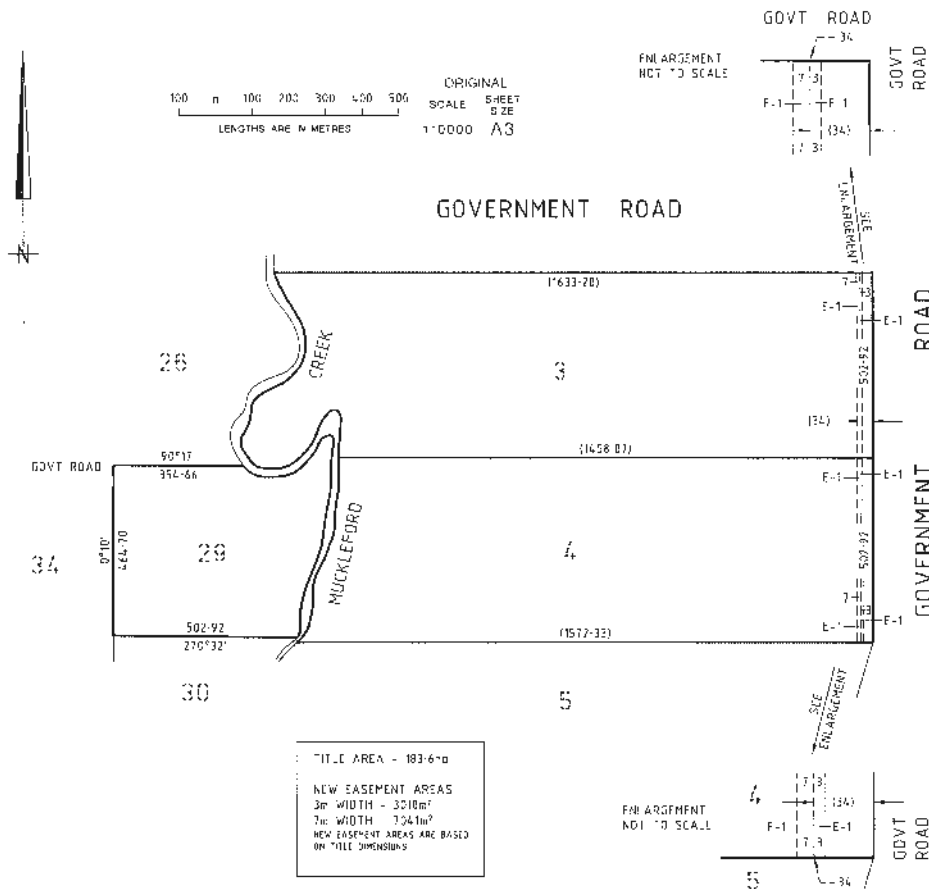

Published with the authority of Central Highlands Region Water Authority.  
 Dated 14 June 2007

Signed by  
**TONY WRIGHT**  
 for and on behalf of  
 Central Highland Region Water Authority  
 CHW Project Director,  
 Goldfields Superpipe

This page was left blank intentionally

This page was left blank intentionally

This page was left blank intentionally

**craftsmanpress**

The *Victoria Government Gazette* is published by The Craftsman Press Pty Ltd with the authority of the Government Printer for the State of Victoria

© State of Victoria 2007

This publication is copyright. No part may be reproduced by any process except in accordance with the provisions of the Copyright Act.

Address all enquiries to the Government Printer for the State of Victoria  
Level 2 1 Macarthur Street  
Melbourne 3002  
Victoria Australia

**How To Order****Mail Order****Victoria Government Gazette**

Level 1 520 Bourke Street  
Melbourne 3000  
PO Box 1957 Melbourne 3001  
DX 106 Melbourne

**Telephone**

(03) 9642 5808

**Fax**

(03) 9600 0478

**email**

gazette@craftpress.com.au

**Retail & Mail Sales****Victoria Government Gazette**

Level 1 520 Bourke Street  
Melbourne 3000  
PO Box 1957 Melbourne 3001

**Telephone**

(03) 9642 5808

**Fax**

(03) 9600 0478

**Retail Sales****Information Victoria**

505 Little Collins Street  
Melbourne 3000

**Telephone**

1300 366 356

**Fax**

(03) 9603 9920

**Price Code B**